



**THE DATASHEET OF
ALBFLB20600**



Fairlead Blocks

Other System Attachments

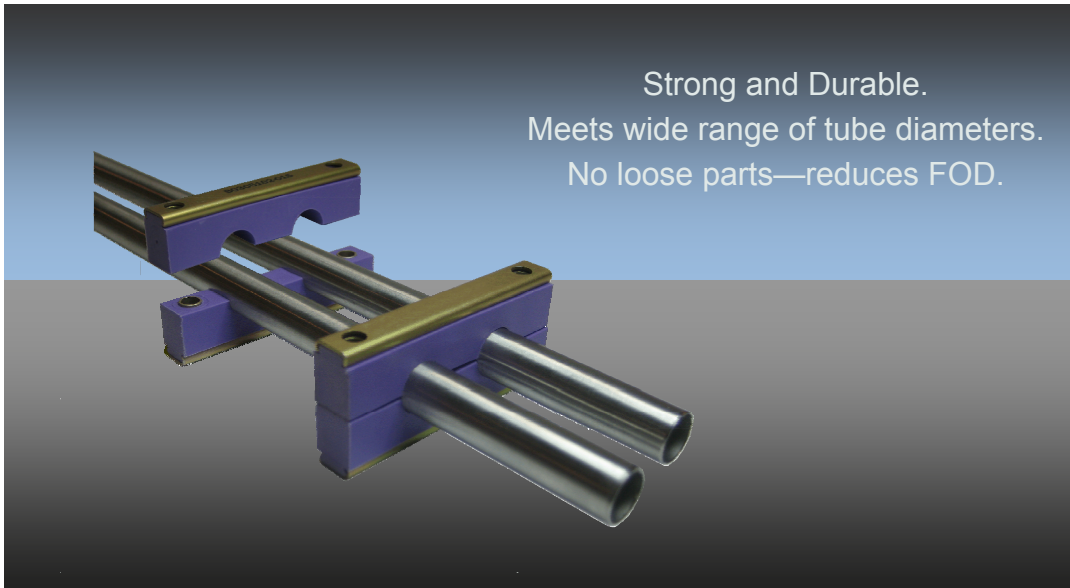

High Performance Clamps



Anchor Supports

Amphenol has over 30 years experience in System Attachment technology, serving the Aerospace, Military, Industrial and extreme environment markets. The company produces high quality products and prides itself on timely and accurate delivery.

Designed to ensure that pipes and tubes are properly secured throughout their entire length, Amphenol's Fairlead Blocks were designed with strength and stability in mind. They provide stability against surges and vibration, and they're developed with material that prevents chaffing. Amphenol's engineering experience enables the company to develop blocks that accommodate a wide range of tube diameters, and the products have no loose parts—reducing the likelihood of FOD. Lastly, Amphenol's service is second to none—offering quick turn-around times and competitive pricing.

Features and Benefits

- Strong and Durable
- Can accommodate wide range of tube diameters
- Various materials are available
- Designed to prevent wire/tube chaffing
- Protects wires/tubes against surges and harsh vibration
- Captive rail design; No loose parts
- Custom design available
- 24/7 engineering capabilities; Quick turn-around time

Other Amphenol Blocks

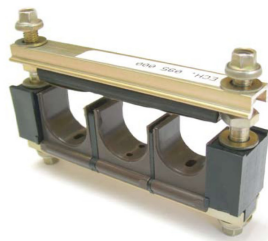

Conductive Tangent Modular Assembly



Lightweight Monobloc—with tube sliding feature



Lightweight Monobloc—with extra cushioning feature

Additional Information

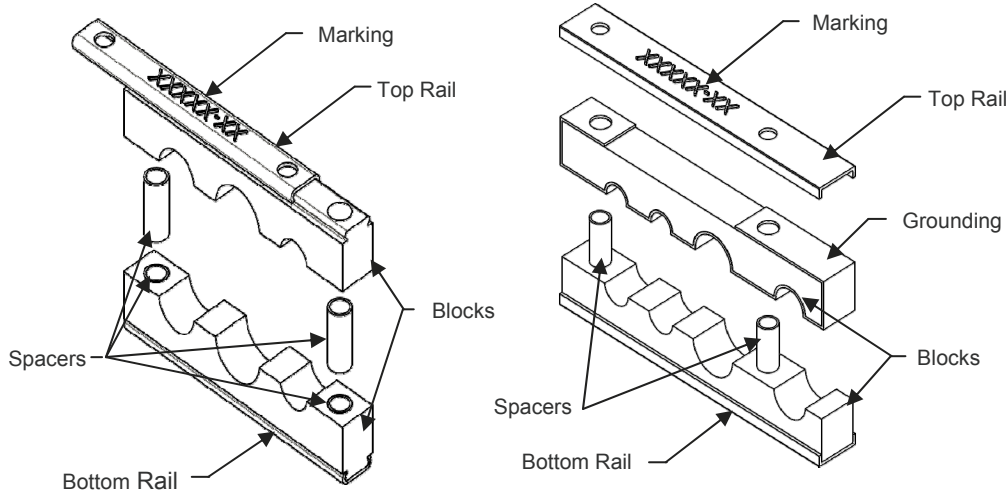

RAILS / SPACERS SPECIFICATIONS

Materials	Coating	Application
Aluminum Alloy 6061-T6 or 2024-T3	Chemical Conversion Coating per Mil-C-5541 Class 1A	Light Duty
Stainless Steel per ASTM A109	Cadmium Plate per QQ-P416, TYPE II Class 1	High Performance
Carbon Fiber Composite	Contact Amphenol for availability and information.	

CUSHION BLOCK SPECIFICATIONS

Materials	Specifications
Ethylene Propylene Rubber (EPR)	Temperature Range: -65°F– 275°F Color: Purple Duro: 55–75 Standard usage: Commercial Aircraft—especially in areas contaminated with Skydrol.
Nitrile Butadienne (Buna-N)	Temperature Range: -65°F– 275°F Color: Black Duro: 55–75 Standard usage: fuel tank applications.
Silicone	Temperature Range: -65°F– 275°F Duro: 55–75 Standard usage: fire resistant, low smoke density, low toxicity requirements
Fluoro-Silicone	Temperature Range: -65°F– 500°F Duro: 55–75 Standard usage: High temperature areas; engine applications

Product Customization

Amphenol AirLB NA welcomes inquiries for application-specific modifications to our Fairlead Block product line. Our pipe supports and system attachments are continuously expanding to meet current and future customer needs.

Related Amphenol Products



Jig Board Clamps



Lightening Bushings



Raceways

Contact Information

Amphenol AirLB NA

3335 1ere Rue
St-Hubert, Qc. J3Y 8Y6 Canada
email: info@amphenol-airlb.com
Tel: 450-445-6007

Looking for pricing, stock, or lifecycle information?

Click below to explore more details on WIN SOURCE:

- ⊖ [View ALBFLB20600 on WIN SOURCE](#)
- ⊖ [Amphenol PCD Information](#)

Optimize Your Supply Chain with WIN SOURCE Solutions

- ✓ Global Sourcing Solution
- ✓ Obsolete Management
- ✓ Cost Control Management
- ✓ Shortage Management
- ✓ Alternative Solution
- ✓ Excess Inventory Management