



**THE DATASHEET OF  
BD8601FV-E2**



**System Power Supply for TV Series****FET Controller Type  
3ch System Power Supply ICs****BD8601FV****●Description**

BD8601FV has realized the high performance and reliability required as a power supply for thin-screen TV.

Due to the high-speed load response, it is most suitable for TV-purpose processors with increasingly high performance, and due to the wide phase margin it leaves a good margin for board pattern & constant setting and so facilitates its application design.

As a high-reliability design, it has various built-in protection circuits (overcurrent protection, output voltage abnormal protection, thermal protection, and off-latch function at the time of abnormality etc.), therefore as an advantage it does not easily damage in every possible abnormal condition such as all-pin short circuit test etc. and hence most suitable for thin-screen TV which requires the high reliability.

**●Features**

- 1) 3ch synchronous rectification step-down system DC/DC converter controller
- 2) 3ch independent ON/OFF. controllable
- 3) Soft start, soft off function
- 4) Concentrated protection control with built-in sequencer
- 5) Built-in low voltage protection function
- 6) Built-in overvoltage protection function
- 7) Built-in overcurrent protection function
- 8) Built-in RT terminal open/short protection function
- 9) Built-in duty clamp (90% ON) function
- 10) Frequency setting by external resistance is available.
- 11) Protection condition is output from PDET terminal.
- 12) Built-in external reset output function

Aug. 2008

• **Electric characteristic**

(Ta=25°C, VIN1, VIN2, VIN3=5.0V, VCC=5.0V, and GND=0V unless otherwise specified.)

Parameter	Symbol	specification value			UNIT	Condition
		MIN	TYP	MAX		
Circuit current 1	I <sub>Q1</sub>	-	3.5	8	mA	CTL1,2,3=0V
Circuit current 2	I <sub>Q2</sub>	-	7	15	mA	CTL1,2,3=VCC
<b>&lt; Error amplifier part Ch1,Ch2,Ch3&gt;</b>						
Standard voltage (VREF)	V <sub>REF</sub>	0.792	0.8	0.808	V	Terminal FB and FC terminal short
Terminal FB Input bias current	I <sub>FBB</sub>	-1	-	1	μA	V <sub>FB</sub> =0.9V
Terminal FC Clamping voltage H	V <sub>FCH</sub>	1.8	-	-	V	V <sub>FB</sub> =0.7V
Terminal FC Clamping voltage L	V <sub>FCL</sub>	-	-	0.2	V	V <sub>FB</sub> =0.9V
Terminal FC Sink current	I <sub>FCSINK</sub>	0.5	-	-	mA	V <sub>FB</sub> =0.9V, V <sub>FC</sub> =0.4V
Terminal FC Source current	I <sub>FCSOURCE</sub>	-	-	-70	μA	V <sub>FB</sub> =0.7V, V <sub>FC</sub> =1.6V
Open loop gain	A <sub>VERR</sub>	-	100	-	dB	
<b>&lt; OSC part &gt;</b>						
Oscillation frequency	F <sub>OSC</sub>	100	-	600	kHz	
<b>&lt; Duty clamping part Ch1,Ch2,Ch3&gt;</b>						
Max ON duty ratio	F <sub>ONDUTY</sub>	70	85	95	%	V <sub>FB</sub> =0.7V
<b>&lt; Soft start part Ch1,Ch2,Ch3&gt;</b>						
Charging current	I <sub>SS</sub>	-4.0	-2.5	-1.0	μA	V <sub>SS</sub> =1.0V
Terminal SS Threshold voltage	V <sub>SSSTH</sub>	1.0	1.1	1.2	V	V <sub>SS</sub> voltage, V <sub>FC</sub> =0.8V
Terminal SS Clamping voltage	V <sub>SSCLM</sub>	1.6	1.9	2.2	V	
Terminal SS Standby voltage	V <sub>SSSTB</sub>	0.11	0.15	0.19	V	V <sub>SS</sub> voltage (L→H)
Terminal SS Standby voltage Maximum hysteresis error	V <sub>SSSTB_HYS</sub>	5	50	100	mV	
Terminal SS Discharge resistance	R <sub>SS</sub>	49	70	91	kΩ	
Terminal SS Protection circuit start voltage	V <sub>SSPON</sub>	1.0	1.1	1.2	V	V <sub>SS</sub> voltage (L→H)
Terminal SS Protection circuit start voltage Maximum hysteresis error	V <sub>SSPON_HYS</sub>	10	100	200	mV	V <sub>SS</sub> voltage
<b>&lt; Low voltage, over voltage detection part Ch1,Ch2,Ch3&gt;</b>						
Terminal FB Low voltage detection voltage	V <sub>LVP</sub>	0.27	0.32	0.37	V	V <sub>FB</sub> voltage
Terminal FB Low voltage detection Maximum hysteresis error	V <sub>LVP_HYS</sub>	10	100	200	mV	V <sub>FB</sub> voltage
Terminal FB Overvoltage detection voltage	V <sub>OVP</sub>	1.08	1.2	1.32	V	V <sub>FB</sub> voltage
<b>&lt; Over current detection part Ch1,Ch2,Ch3&gt;</b>						
Terminal LX input bias current	I <sub>LXB</sub>	-1	0	1	μA	
Terminal OCP input bias current	I <sub>OCPB</sub>	20	50	80	μA	
<b>&lt; Reset detection part &gt;</b>						
Terminal MONVCC reset detection voltage	V <sub>RSTO</sub>	0.98	1.0	1.02	V	V <sub>MONVCC</sub> voltage (H→L)
Terminal MONVCC input bias current	I <sub>MONVCCB</sub>	-1	-	1	μA	
Terminal RSTDLY charging current	I <sub>RSTDLY</sub>	-15	-10	-5	μA	
Terminal RESET L output voltage	V <sub>OL_RST</sub>	-	-	0.4	V	I <sub>OL</sub> =100μA
<b>&lt; Others &gt;</b>						
Terminal PDET L output voltage	V <sub>OL_RDET</sub>	-	-	0.4	V	I <sub>OL</sub> =100μA
Terminal CTL input voltage H level voltage	V <sub>IH_CTL</sub>	2.0	-	VCC	V	Terminal CTL1,2,3
Terminal CTL input voltage L level voltage	V <sub>IL_CTL</sub>	-	-	0.5	V	Terminal CTL1,2,3
Terminal CTL input current	I <sub>I_CTL</sub>	-	85	120	μA	Terminal CTL1,2,3, CTL=VCC
Terminal DRV H output voltage	V <sub>OH_DRV</sub>	8.5	-	-	V	Terminal DRV1A,2A,3A,1B,2B,3B
Terminal DRV L output voltage	V <sub>OL_DRV</sub>	-	-	0.5	V	Terminal DRV1A,2A,3A,1B,2B,3B

V<sub>FB</sub> : FB terminal voltage, V<sub>FC</sub> : FC terminal voltage, V<sub>SS</sub> : SS terminal voltage, V<sub>MONVCC</sub> : MONVCC terminal voltage

Not designed for radiation resistance.

Current capability should not exceed Pd.

● Block diagram

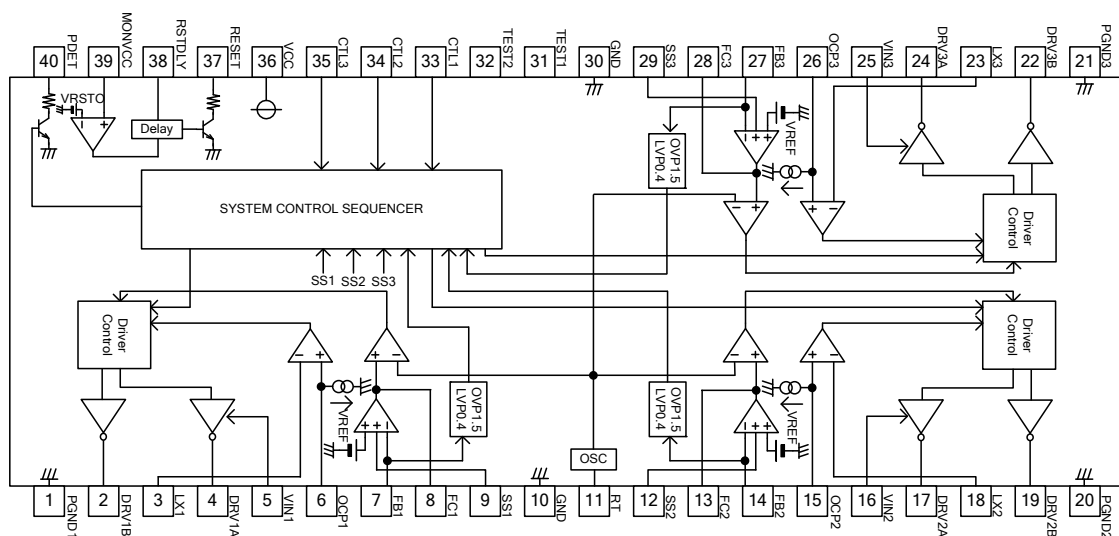

Figure 1 block char

● Terminal explanation

Table 1 terminal explanation

No.	Symbol	Description	No.	Symbol	Description
1	PGND1	Ch1 power GND (same potential as GND terminal)	40	PDET	Off latch signal output
2	DRV1B	Ch1 Nch drive output terminal	39	MONVCC	VCC monitor terminal
3	LX1	Ch1 overcurrent detection terminal	38	RSTDLY	Reset delay adjustment capacity connection terminal
4	DRV1A	Ch1 Pch drive output terminal	37	RESET	Reset output terminal
5	VIN1	Ch1 power supply input terminal	36	VCC	Power supply input terminal
6	OCP1	Ch1 overcurrent detection level resistance connection terminal	35	CTL3	Ch3 control terminal
7	FB1	Ch1 voltage detection terminal	34	CTL2	Ch2 control terminal
8	FC1	Ch1 phase compensation terminal	33	CTL1	Ch1 control terminal
9	SS1	Ch1 soft start adjustment capacity connection terminal	32	TEST2	Test terminal (connect to GND)
10	GND	GND (0V connection)	31	TEST1	Test terminal (Connect to GND)
11	RT	Frequency adjustment resistance connection terminal	30	GND	GND (0V connection)
12	SS2	Ch2 soft start adjustment capacity connection terminal	29	SS3	Ch3 soft start adjustment capacity connection terminal
13	FC2	Ch2 phase compensation terminal	28	FC3	Ch3 phase compensation terminal
14	FB2	Ch2 voltage detection terminal	27	FB3	Ch3 voltage detection terminal
15	OCP2	Ch2 overcurrent detection level resistance connection terminal	26	OCP3	Ch3 overcurrent detection level resistance connection terminal
16	VIN2	Ch2 power supply input terminal	25	VIN3	Ch3 power supply input terminal
17	DRV2A	Ch2 Pch drive output terminal	24	DRV3A	Ch3 Pch drive output terminal
18	LX2	Ch2 overcurrent detection terminal	23	LX3	Ch3 overcurrent detection terminal
19	DRV2B	Ch2 Nch drive output terminal	22	DRV3B	Ch3 Nch drive output terminal
20	PGND2	Ch2 power GND (same potential as terminal GND)	21	PGND3	Ch3 power GND (same potential as terminal GND)

● Terminal equivalent circuit chart

Terminal No.	Terminal name	Explanation	Terminal equivalent circuit chart
1	PGND1	Ch1 Power GND (GND Terminal and this potential)	
20	PGND2	Ch2 Power GND (GND Terminal and this potential)	
21	PGND3	Ch3 Power GND (GND Terminal and this potential)	
2	DRV1B	Ch1 Nch Driving output terminal	
19	DRV2B	Ch2 Nch Driving output terminal	
22	DRV3B	Ch3 Nch Driving output terminal	
3	LX1	Ch1 Over current detection terminal	
18	LX2	Ch2 Over current detection terminal	
23	LX3	Ch3 Over current detection terminal	
4	DRV1A	Ch1 Pch Driving output terminal	
17	DRV2A	Ch2 Pch Driving output terminal	
24	DRV3A	Ch3 Pch Driving output terminal	
5	VIN1	Ch1 Power supply input terminal	
16	VIN2	Ch2 Power supply input terminal	
25	VIN3	Ch3 Power supply input terminal	

Terminal No.	Terminal name	Explanation	Terminal equivalent circuit chart
6	OCP1	Ch1 Over current detection level Set resistance connection terminal	
15	OCP2	Ch2 Over current detection level Set resistance connection terminal	
26	OCP3	Ch3 Over current detection level Set resistance connection terminal	
7	FB1	Ch1 Voltage detection terminal	
14	FB2	Ch2 Voltage detection terminal	
27	FB3	Ch3 Voltage detection terminal	
8	FC1	Ch1 Phase amends terminal	
13	FC2	Ch2 Phase amends terminal	
28	FC3	Ch3 Phase amends terminal	

Terminal No..	Terminal name	Explanation	Terminal equivalent circuit chart
9	SS1	Ch1 Soft start Adjustment capacity connection terminal	
12	SS2	Ch2 Soft start Adjustment capacity connection terminal	
29	SS3	Ch3 Soft start Adjustment capacity connection terminal	
10	GND	GND (0V Connection)	
30	GND	GND (0V Connection)	
11	RT	Frequency adjustment resistance connection terminal	
31	TEST1	Test terminal	
32	TEST2	Test terminal	
33	CTL1	Ch1 Control terminal	
34	CTL2	Ch2 Control terminal	
35	CTL3	Ch3 Control terminal	

Terminal No.	Terminal name	Explanation	Terminal equivalent circuit chart
36	VCC	Power supply input terminal	
37	RESET	Reset output terminal	
38	RSTDLY	Reset Delay Adjustment capacity connection terminal	
39	MONVCC	VCC Monitor terminal	
40	PDET	Off latch output terminal	

● **Operation description**

ON/OFF control

DC/DC converter controller ON/OFF function

DC/DC converter controller of each Ch can be independently controlled ON/OFF by CTL1, CTL2, and CTL3 terminal. Analog circuit of Ch interlocked to each CTL terminal starts operation at ON control (on mode), and goes down to setting output voltage. Analog circuit of Ch interlocked to each CTL terminal should be standby at OFF control (off mode), and output voltage becomes 0V.

Table1 DC/DC converter controller ON/OFF function

CTL1 terminal voltage	Ch1	CTL2 terminal voltage	Ch2	CTL3 terminal voltage	Ch3
>VIHCTL1	ON control	>VIHCTL2	ON control	>VIHCTL3	ON control
<VILCTL1	OFF control	<VILCTL2	OFF control	<VILCTL3	OFF control

Soft start time set function

DC/DC converter controller of each Ch can do soft start without overshoot by charging soft start capacity (C<sub>SS</sub>) connected between ss terminal and GND in each Ch by charging current at ON control. The mute of the output is released when it reaches V<sub>SS</sub>=0.15V (V<sub>SSSTB</sub>), and the output voltage does the soft start operation from the point of V<sub>SS</sub>=0.3V (typ) in proportion to the voltage of the terminal SS. Also, soft start time (t<sub>SS</sub>) can be set by setting soft start capacity arbitrarily. Soft start time (t<sub>SS</sub>) should be set at 3msec < t<sub>SS</sub> < 30msec.

$$t_{SS} = \frac{V_{SSSTH} \times C_{SS}}{I_{SS}}$$

Discharge function

DC/DC converter controller of each Ch can do soft off by discharging load discharged to soft start capacity connected between SS terminal to GND by discharging resistance at OFF control. Soft off operates in proportion to the voltage of the terminal SS the output voltage from the point of V<sub>SS</sub>=0.8V (typ).

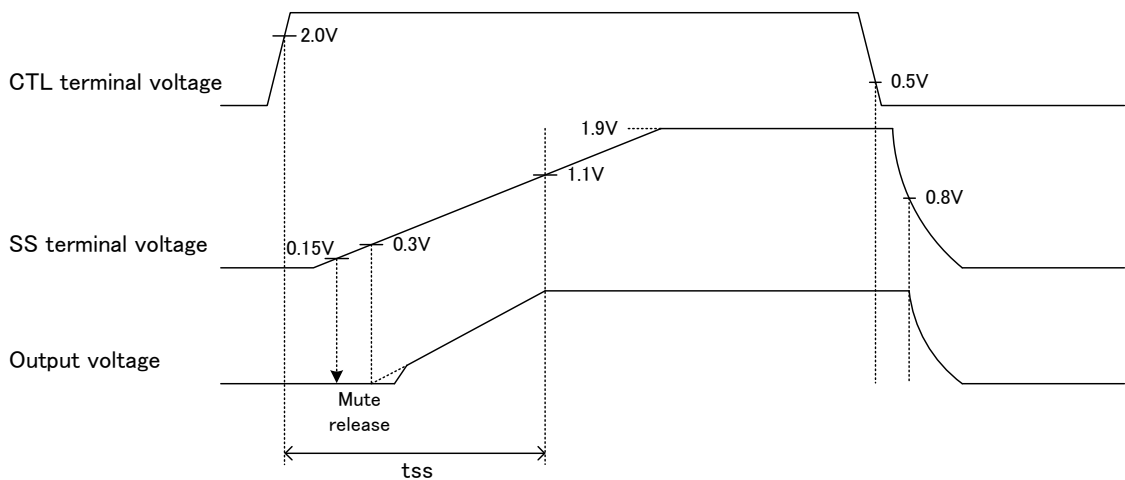

Figure 2 Wave form at ON/OFF control

OSC oscillation frequency setting function

DRVA and DRVB output oscillation frequency of DC/DC converter controller of each Ch can be set by installing resistance between RT terminal and GND externally.

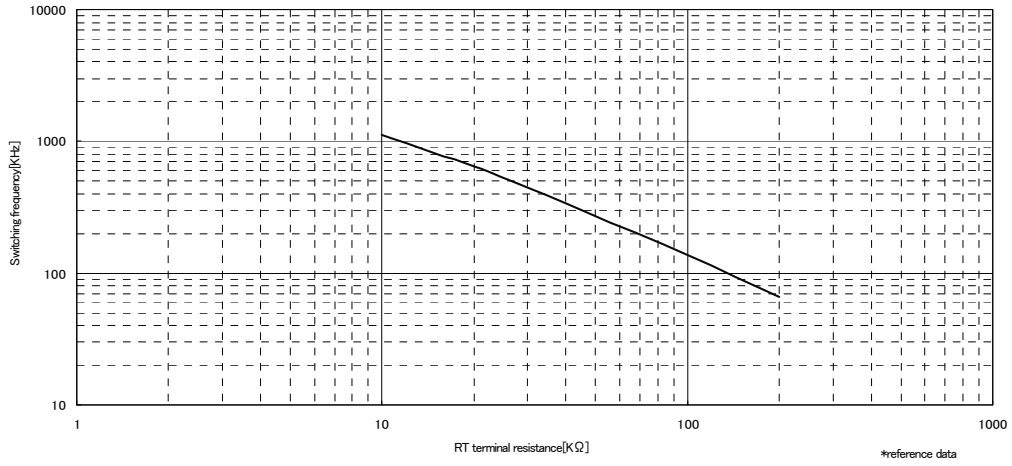

Figure 3 Terminal RT resistance-oscillation frequency

Off latch signal output function

PDET terminal outputs condition of off latch when protection operation of DC/DC converter controller of each Ch operates.

Table 2 PDET terminal off latch signal output function

Protection operation	Terminal PDET
ON	LOW
OFF	Hi-Z

Reset output function

Reset output function observes voltage value from MONVCC terminal and does reset operation compared to internal reference level.

Set MONVCC terminal external resistance to make VCC voltage more than 5.0V at reset release.

Table 3 DC/DC converter controller ON/OFF function

MONVCC terminal voltage	RESET terminal
< 1.0V(typ)	LOW
> 1.072V(typ)	Hi-Z

Delay time until detecting reset release is settable by capacitor connected to RSTDLY terminal.

$$T_{RSTDLY} = \frac{1.235V \times C_{RSTDLY}}{I_{RSTDLY}}$$

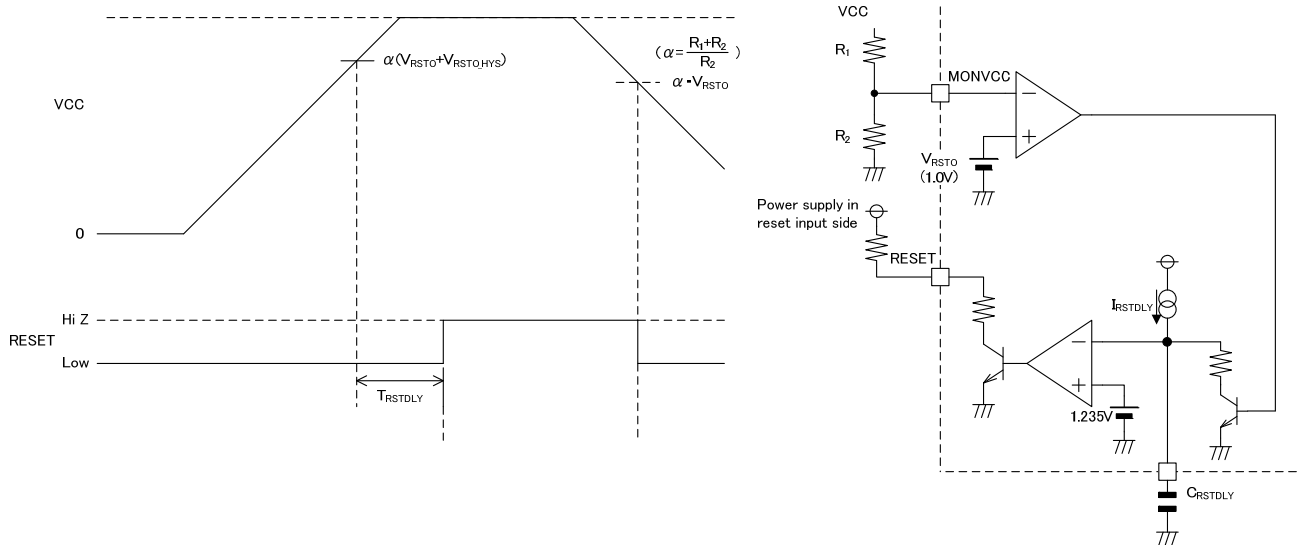

T<sub>RSTDLY</sub>: Delay time until detecting reset release

Figure 4 reset operation

● Protection function

Protection circuit is effective for destruction prevention due to accident so that avoid using by continuous protection operation.

Low voltage protection function(LVP)

Low voltage protection function detects output voltage  $V_O$  set in each Ch from FB terminal of each Ch and off-latched all DC/DC converter controller compared to internal reference level.

Low voltage protection function operates when FB terminal voltage falls below  $V_{LVP}$  ( $=1.5 \times V_{REF}$ ) and continues about more than  $400\mu\text{sec}$  (typ).

Table 4 Low voltage protection function

CTL terminal	SS terminal	FB terminal	Low voltage protection function	Low voltage protection operation
$>V_{IHCTL}$	$>1.1V(\text{typ})$	$<V_{LVP}$	Enable	ON
		$>V_{LVP}+V_{LVP\_HYS}$		OFF
	$<1.0V(\text{typ})$	-	Disable	OFF
$<V_{ILCTL}$	-	-	Disable	OFF

※Constant voltage protection function is enabled when SS terminal voltage of each Ch becomes more than  $1.1V$  (typ) in the transition to ON control (during soft start).

Overvoltage protection function(OVP)

Overvoltage protection function detects output voltage  $V_O$  set in each Ch from FB terminal of each Ch and off-latched all DC/DC converter controller compared to internal reference level.

Overvoltage protection function operates when FB terminal voltage exceeds  $V_{OVP}$  ( $=1.5 \times V_{REF}$ ) and continues about more than  $400\mu\text{sec}$  (typ).

Table 5 Overvoltage protection function

CTL terminal	SS terminal	FB terminal	Overvoltage protection function	Overvoltage protection operation
$>V_{IHCTL}$	$>1.1V(\text{typ})$	$>V_{OVP}$	Effective	ON
		$<V_{OVP}$		OFF
	$<1.0V(\text{typ})$	-	Invalidity	OFF
$<V_{ILCTL}$	-	-	Invalidity	OFF

※Overvoltage protection function is enabled when SS terminal voltage of each Ch becomes more than  $1.1V$  (typ) in the transition to ON control (during soft start).

Overcurrent protection function(OCP)

Overcurrent protection function compared drain voltage (LX terminal voltage) with OCP terminal voltage when external Pch POWER MOS is ON. When LX terminal voltage becomes lower than OCP terminal voltage, external MOS would be OFF. Up to 50uA (typ) of constant current from OCP terminal is synchronized. Overcurrent detection level (OCP terminal voltage) can be set arbitrarily by external resistance value.

Off latch by overcurrent protection function operates when LX terminal voltage falls below OCP terminal voltage and continues about more than 400μsec (typ).

Table 6 overcurrent protection function

CTL terminal	SS terminal	LX terminal voltage	Overcurrent protection function	Overcurrent protection operation
>VIHCTL	>1.1V(typ)	<VOCP	Enable	ON
		>VOCP		OFF
<VILCTL	<1.0V(typ)	-	Disable	OFF
	-	-	Disable	OFF

※Set OCP terminal voltage to be more than VIN-2.5V (typ).

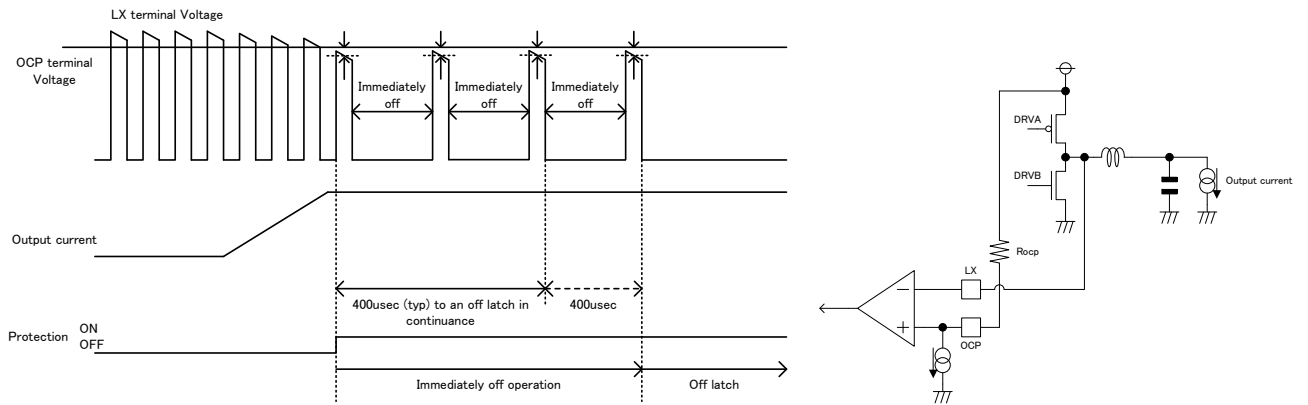
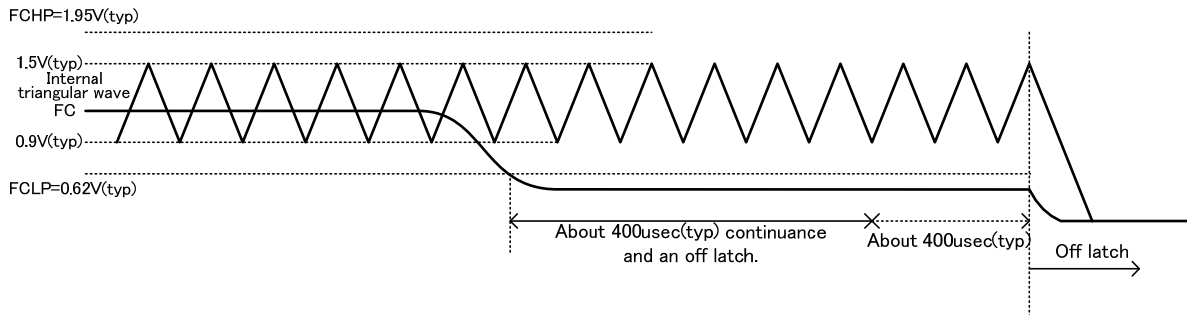
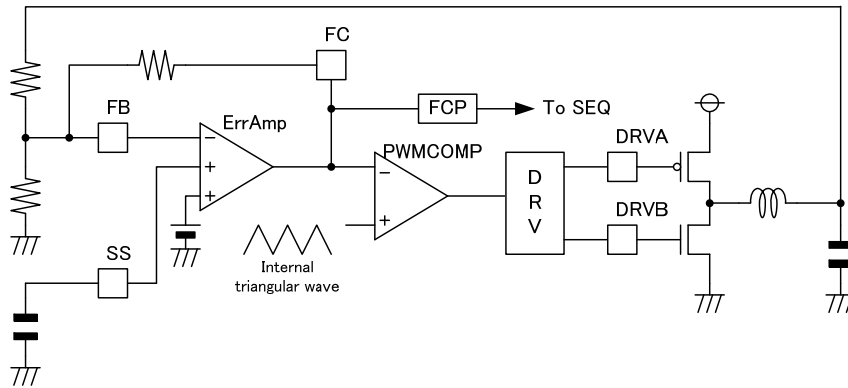

Figure 5-2. Overcurrent protection

Terminal FC abnormality protection function



The terminal FC abnormality protection function operates in all DC/DC converter controller detecting the continuance of the state that FC which is the difference input of PWMCOMP does not intersect with an internal triangular wave. The terminal FC abnormality protection function is exceeded 1.95V(typ) by the voltage of the terminal FC or operates when it falls below 0.62V(typ), and about 400µsec(typ) or more continues.

CTL terminal	SS terminal	Protection operation	FC terminal	Terminal FC abnormality protection operation
$> V_{IHCTL}$	$> 1.1V(\text{typ})$	Enable	$> 1.95V(\text{typ})$	ON
			$0.62V(\text{typ}) < , < 1.95V(\text{typ})$	OFF
$< V_{IHCTL}$	$< 1.0V(\text{typ})$	Disable	$< 0.62V(\text{typ})$	ON
			-	OFF

※Terminal FC abnormality protection function is enabled when SS terminal voltage of each Ch becomes more than 1.1V (typ) in the transition to ON control (during soft start).

RT terminal open/short protection function

RT terminal open/short protection function off-latches all DC/DC converter controller by detecting open/short condition internally from RT terminal to prevent from output voltage error caused by abnormal oscillation of internal triangular wave at RT terminal open/short.

RT terminal open/short protection function is regularly enabled after boot-up.

RT terminal open/short protection function operates when error detection condition continues about more than 400µsec (typ).

### Soft start time-out function

Each Ch DC/DC converter controller off-latch-controls when  $V_{SS}$  does not exceed  $V_{SSPON}$  from  $V_{SS} > V_{SSSTB} + V_{SSSTB\_HYS}$  after 50msec (typ) passed from soft start.

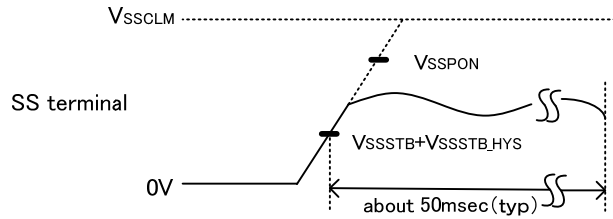

Figure 5-3. At soft start time-out

### Error detection (off latch) release method

Each Ch DC/DC converter controller comes into off latch condition when protection function operates. Off latch can be released by the following method. Each Ch DC/DC converter controller becomes able to do ON control transition by releasing off latch.

1. Set all Ch CTL terminal voltage as  $< V_{ILCTL}$  and continue that condition about more than 200usec (typ).
2. Drop down power supply VCC to below 4.5V.

# SSOP-B40

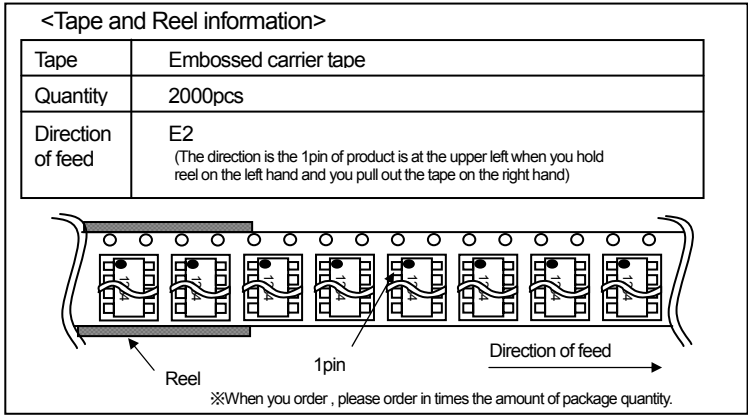
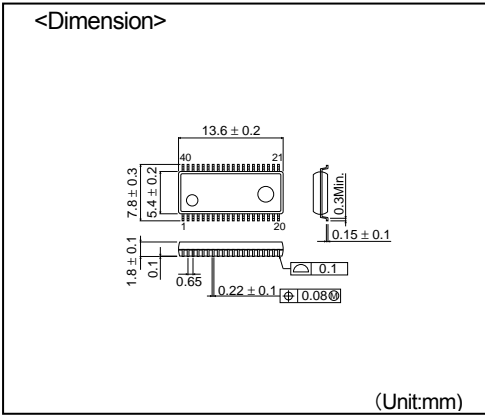

- The contents described herein are correct as of August, 2008
- The contents described herein are subject to change without notice. For updates of the latest information, please contact and confirm with ROHM CO.,LTD.
- Any part of this application note must not be duplicated or copied without our permission.
- Application circuit diagrams and circuit constants contained herein are shown as examples of standard use and operation. Please pay careful attention to the peripheral conditions when designing circuits and deciding upon circuit constants in the set.
- Any data, including, but not limited to application circuit diagrams and information, described herein are intended only as illustrations of such devices and not as the specifications for such devices. ROHM CO.,LTD. disclaims any warranty that any use of such devices shall be free from infringement of any third party's intellectual property rights or other proprietary rights, and further, assumes no liability of whatsoever nature in the event of any such infringement, or arising from or connected with or related to the use of such devices.
- Upon the sale of any such devices, other than for buyer's right to use such devices itself, resell or otherwise dispose of the same, implied right or license to practice or commercially exploit any intellectual property rights or other proprietary rights owned or controlled by ROHM CO., LTD. is granted to any such buyer.
- The products described herein utilize silicon as the main material.
- The products described herein are not designed to be X ray proof.

The products listed in this catalog are designed to be used with ordinary electronic equipment or devices (such as audio visual equipment, office-automation equipment, communications devices, electrical appliances and electronic toys). Should you intend to use these products with equipment or devices which require an extremely high level of reliability and the malfunction of which would directly endanger human life (such as medical instruments, transportation equipment, aerospace machinery, nuclear-reactor controllers, fuel controllers and other safety devices), please be sure to consult with our sales representative in advance.

## Contact us for further information about the products.

<b>San Diego</b>	TEL: +1-858-625-3630	FAX: +1-858-625-3670	<b>Tianjin</b>	TEL: +86-22-23029181	FAX: +86-22-23029183
<b>Atlanta</b>	TEL: +1-770-754-5972	FAX: +1-770-754-0691	<b>Shanghai</b>	TEL: +86-21-6279-2727	FAX: +86-21-6247-2066
<b>Boston</b>	TEL: +1-978-371-0382	FAX: +1-928-438-7164	<b>Hangzhou</b>	TEL: +86-571-87658072	FAX: +86-571-87658071
<b>Chicago</b>	TEL: +1-847-368-1006	FAX: +1-847-368-1008	<b>Nanjing</b>	TEL: +86-25-8689-0015	FAX: +86-25-8689-0393
<b>Dallas</b>	TEL: +1-469-287-5366	FAX: +1-469-362-7973	<b>Ningbo</b>	TEL: +86-574-87654201	FAX: +86-574-87654208
<b>Denver</b>	TEL: +1-303-708-0908	FAX: +1-303-708-0858	<b>Qingdao</b>	TEL: +86-532-5779-312	FAX: +86-532-5779-653
<b>Detroit</b>	TEL: +1-248-348-9920	FAX: +1-248-348-9942	<b>Suzhou</b>	TEL: +86-510-82702693	FAX: +86-510-82702992
<b>Nashville</b>	TEL: +1-615-620-6700	FAX: +1-615-620-6702	<b>Wuxi</b>	TEL: +86-510-82702693	FAX: +86-510-82702992
<b>Mexico</b>	TEL: +52-33-3123-2001	FAX: +52-33-3123-2002	<b>Shenzhen</b>	TEL: +86-755-8307-3008	FAX: +86-755-8307-3003
<b>Düsseldorf</b>	TEL: +49-2154-9210	FAX: +49-2154-921400	<b>Dongguan</b>	TEL: +86-769-8393-3320	FAX: +86-769-8398-4140
<b>Munich</b>	TEL: +49-8999-216168	FAX: +49-8999-216176	<b>Fuzhou</b>	TEL: +86-591-8801-8698	FAX: +86-591-8801-8690
<b>Stuttgart</b>	TEL: +49-711-7272-370	FAX: +49-711-7272-3720	<b>Guangzhou</b>	TEL: +86-20-3878-8100	FAX: +86-20-3825-5965
<b>France</b>	TEL: +33-1-5697-3060	FAX: +33-1-5697-3080	<b>Huizhou</b>	TEL: +86-752-205-1054	FAX: +86-752-205-1059
<b>United Kingdom</b>	TEL: +44-1-908-306700	FAX: +44-1-908-235788	<b>Xiamen</b>	TEL: +86-592-238-5705	FAX: +86-592-239-8380
<b>Denmark</b>	TEL: +45-3694-4739	FAX: +45-3694-4789	<b>Zhuhai</b>	TEL: +86-756-3232-480	FAX: +86-756-3232-460
<b>Espoo</b>	TEL: +358-9725-54491	FAX: +358-9-7255-4499	<b>Hong Kong</b>	TEL: +852-2-740-6262	FAX: +852-2-375-8971
<b>Salo</b>	TEL: +358-2-7332234	FAX: +358-2-7332237	<b>Taipei</b>	TEL: +886-2-2500-6956	FAX: +886-2-2503-2869
<b>Oulu</b>	TEL: +358-8-5372930	FAX: +358-8-5372931	<b>Kaohsiung</b>	TEL: +886-7-237-0881	FAX: +886-7-238-7332
<b>Barcelona</b>	TEL: +34-9375-24320	FAX: +34-9375-24410	<b>Singapore</b>	TEL: +65-6332-2322	FAX: +65-6332-5662
<b>Hungary</b>	TEL: +36-1-4719338	FAX: +36-1-4719339	<b>Philippines</b>	TEL: +63-2-807-6872	FAX: +63-2-809-1422
<b>Poland</b>	TEL: +48-22-5757213	FAX: +48-22-5757001	<b>Thailand</b>	TEL: +66-2-254-4890	FAX: +66-2-256-6334
<b>Russia</b>	TEL: +7-495-739-41-74	FAX: +7-495-739-41-74	<b>Kuala Lumpur</b>	TEL: +60-3-7958-8355	FAX: +60-3-7958-8377
<b>Seoul</b>	TEL: +82-2-8182-700	FAX: +82-2-8182-715	<b>Penang</b>	TEL: +60-4-2286453	FAX: +60-4-2286452
<b>Masan</b>	TEL: +82-55-240-6234	FAX: +82-55-240-6236	<b>Kyoto</b>	TEL: +81-75-365-1218	FAX: +81-75-365-1228
<b>Dalian</b>	TEL: +86-411-8230-8549	FAX: +86-411-8230-8537	<b>Yokohama</b>	TEL: +81-45-476-2290	FAX: +81-45-476-2295
<b>Beijing</b>	TEL: +86-10-8525-2483	FAX: +86-10-8525-2489			

Excellence in Electronics

# ROHM

## ROHM CO., LTD.

21 Saiin Mizosaki-cho, Ukyo-ku, Kyoto  
615-8585, Japan  
TEL: +81-75-311-2121 FAX: +81-75-315-0172  
URL: <http://www.rohm.com>

Published by  
KTC LSI Development Headquarters  
LSI Business Promotion Group

### Notes

- No technical content pages of this document may be reproduced in any form or transmitted by any means without prior permission of ROHM CO.,LTD.
- The contents described herein are subject to change without notice. The specifications for the product described in this document are for reference only. Upon actual use, therefore, please request that specifications to be separately delivered.
- Application circuit diagrams and circuit constants contained herein are shown as examples of standard use and operation. Please pay careful attention to the peripheral conditions when designing circuits and deciding upon circuit constants in the set.
- Any data, including, but not limited to application circuit diagrams information, described herein are intended only as illustrations of such devices and not as the specifications for such devices. ROHM CO.,LTD. disclaims any warranty that any use of such devices shall be free from infringement of any third party's intellectual property rights or other proprietary rights, and further, assumes no liability of whatsoever nature in the event of any such infringement, or arising from or connected with or related to the use of such devices.
- Upon the sale of any such devices, other than for buyer's right to use such devices itself, resell or otherwise dispose of the same, no express or implied right or license to practice or commercially exploit any intellectual property rights or other proprietary rights owned or controlled by
- ROHM CO., LTD. is granted to any such buyer.
- Products listed in this document are no antiradiation design.

The products listed in this document are designed to be used with ordinary electronic equipment or devices (such as audio visual equipment, office-automation equipment, communications devices, electrical appliances and electronic toys).

Should you intend to use these products with equipment or devices which require an extremely high level of reliability and the malfunction of which would directly endanger human life (such as medical instruments, transportation equipment, aerospace machinery, nuclear-reactor controllers, fuel controllers and other safety devices), please be sure to consult with our sales representative in advance.

It is our top priority to supply products with the utmost quality and reliability. However, there is always a chance of failure due to unexpected factors. Therefore, please take into account the derating characteristics and allow for sufficient safety features, such as extra margin, anti-flammability, and fail-safe measures when designing in order to prevent possible accidents that may result in bodily harm or fire caused by component failure. ROHM cannot be held responsible for any damages arising from the use of the products under conditions out of the range of the specifications or due to non-compliance with the NOTES specified in this catalog.

Thank you for your accessing to ROHM product informations.

More detail product informations and catalogs are available, please contact your nearest sales office.

**ROHM** Customer Support System



THE AMERICAS / EUROPE / ASIA / JAPAN

[www.rohm.com](http://www.rohm.com)





Contact us : [webmaster@rohm.co.jp](mailto:webmaster@rohm.co.jp)

## Looking for pricing, stock, or lifecycle information?

Click below to explore more details on WIN SOURCE:

-  [View BD8601FV-E2 on WIN SOURCE](#)
-  [Rohm Semiconductor](#) Information

## Optimize Your Supply Chain with WIN SOURCE Solutions

-  Global Sourcing Solution
-  Obsolete Management
-  Cost Control Management
-  Shortage Management
-  Alternative Solution
-  Excess Inventory Management