



**THE DATASHEET OF
BLF645,112**



1. Product profile

1.1 General description

A 100 W LDMOS RF power push-pull transistor for broadcast transmitter and industrial applications. The transistor is suitable for the frequency range HF to 1400 MHz. The excellent ruggedness and broadband performance of this device makes it ideal for digital applications.

Table 1. Typical performance

RF performance at $T_h = 25\text{ °C}$ in a common source test circuit.

Mode of operation	f (MHz)	V _{DS} (V)	P _L (W)	P _{L(PEP)} (W)	G _p (dB)	η _D (%)	IMD (dBc)
CW, class-AB	1300	32	100	-	18	56	-
2-tone, class-AB	1300	32	-	100	18	45	-32

1.2 Features

- CW performance at 1300 MHz, a drain-source voltage V_{DS} of 32 V and a quiescent drain current I_{Dq} = 0.9 A for total device:
 - ◆ Average output power = 100 W
 - ◆ Power gain = 18 dB
 - ◆ Drain efficiency = 56 %
- 2-tone performance at 1300 MHz, a drain-source voltage V_{DS} of 32 V and a quiescent drain current I_{Dq} = 0.9 A for total device:
 - ◆ Peak envelope load power = 100 W
 - ◆ Power gain = 18 dB
 - ◆ Drain efficiency = 45 %
 - ◆ Intermodulation distortion = -32 dBc
- Integrated ESD protection
- Excellent ruggedness
- High power gain
- High efficiency
- Excellent reliability
- Easy power control
- Compliant to Directive 2002/95/EC, regarding Restriction of Hazardous Substances (RoHS)

1.3 Applications

- Communication transmitter applications in the HF to 1400 MHz frequency range
- Industrial applications in the HF to 1400 MHz frequency range

2. Pinning information

Table 2. Pinning

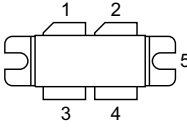
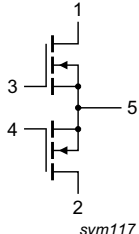
Pin	Description	Simplified outline	Graphic symbol
1	drain 1		
2	drain 2		
3	gate 1		
4	gate2		
5	source		

[1] Connected to flange.

3. Ordering information

Table 3. Ordering information

Type number	Package		Version
	Name	Description	
BLF645	-	flanged balanced LDMOST ceramic package; 2 mounting holes; 4 leads	SOT540A

4. Limiting values

Table 4. Limiting values

In accordance with the Absolute Maximum Rating System (IEC 60134).

Symbol	Parameter	Conditions	Min	Max	Unit
V_{DS}	drain-source voltage		-	65	V
V_{GS}	gate-source voltage		-0.5	+11	V
I_D	drain current		-	32	A
T_{stg}	storage temperature		-65	+150	°C
T_j	junction temperature		-	200	°C

5. Thermal characteristics

Table 5. Thermal characteristics

Symbol	Parameter	Conditions	Typ	Unit
$R_{th(j-c)}$	thermal resistance from junction to case	$T_{case} = 80\text{ °C}; P_L = 100\text{ W}$	[1]	0.67 K/W

[1] $R_{th(j-c)}$ is measured under RF conditions.

6. Characteristics

Table 6. Characteristics per section

$T_j = 25\text{ }^\circ\text{C}$ per section; unless otherwise specified.

Symbol	Parameter	Conditions	Min	Typ	Max	Unit
$V_{(BR)DSS}$	drain-source breakdown voltage	$V_{GS} = 0\text{ V}; I_D = 0.9\text{ mA}$	65	-	-	V
$V_{GS(th)}$	gate-source threshold voltage	$V_{DS} = 32\text{ V}; I_D = 90\text{ mA}$	1.4	1.9	2.4	V
V_{GSq}	gate-source quiescent voltage	$V_{DS} = 32\text{ V}; I_{Dq} = 450\text{ mA}$	1.5	2.0	2.5	V
I_{DSS}	drain leakage current	$V_{GS} = 0\text{ V}; V_{DS} = 32\text{ V}$	-	-	1.4	μA
I_{DSX}	drain cut-off current	$V_{GS} = V_{GS(th)} + 3.75\text{ V};$ $V_{DS} = 10\text{ V}$	-	14	-	A
I_{GSS}	gate leakage current	$V_{GS} = \pm 10\text{ V}; V_{DS} = 0\text{ V}$	-	-	120	nA
g_{fs}	forward transconductance	$V_{DS} = 10\text{ V}; I_D = 4.5\text{ A}$	-	6.4	-	S
$R_{DS(on)}$	drain-source on-state resistance	$V_{GS} = V_{GS(th)} + 3.75\text{ V};$ $I_D = 3.15\text{ A}$	-	220	-	$\text{m}\Omega$
C_{iss}	input capacitance	$V_{GS} = 0\text{ V}; V_{DS} = 32\text{ V};$ $f = 1\text{ MHz}$	-	69	-	pF
C_{oss}	output capacitance	$V_{GS} = 0\text{ V}; V_{DS} = 32\text{ V};$ $f = 1\text{ MHz}$	-	25	-	pF
C_{rs}	feedback capacitance	$V_{GS} = 0\text{ V}; V_{DS} = 32\text{ V};$ $f = 1\text{ MHz}$	-	1.2	-	pF

7. Application information

Table 7. RF performance in a common-source class-AB circuit

$T_h = 25\text{ }^\circ\text{C}; I_{Dq} = 0.9\text{ A}$ for total device.

Mode of operation	f (MHz)	V_{DS} (V)	P_L (W)	G_p (dB)	η_D (%)
CW, class-AB	1300	32	100	> 16.5	> 53

7.1 Ruggedness in class-AB operation

The BLF645 is capable of withstanding a load mismatch corresponding to VSWR = 10 : 1 through all phases under the following conditions: $V_{DS} = 32\text{ V}; f = 1300\text{ MHz}$ at rated load power.

8. Test information

8.1 RF performance

The following figures are measured in a class-AB production test circuit.

8.1.1 1-Tone CW

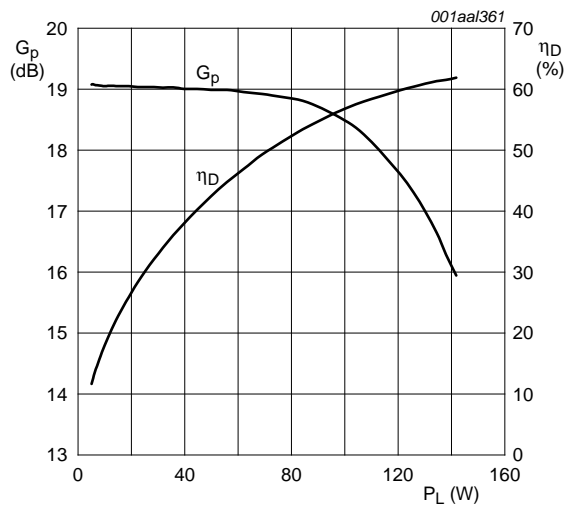

$V_{DS} = 32$ V; $I_{Dq} = 900$ mA (for total device);
 $f = 1300$ MHz.

Fig 1. Power gain and drain efficiency as function of load power; typical values

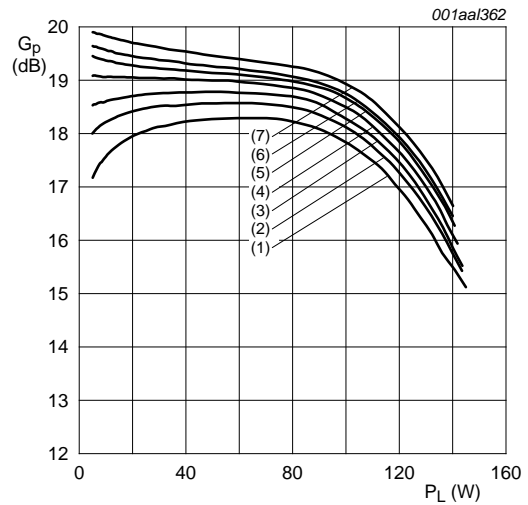

$V_{DS} = 32$ V; $f = 1300$ MHz.

- (1) $I_{Dq} = 200$ mA (for total device).
- (2) $I_{Dq} = 400$ mA (for total device).
- (3) $I_{Dq} = 600$ mA (for total device).
- (4) $I_{Dq} = 900$ mA (for total device).
- (5) $I_{Dq} = 1200$ mA (for total device).
- (6) $I_{Dq} = 1400$ mA (for total device).
- (7) $I_{Dq} = 1800$ mA (for total device).

Fig 2. Power gain as a function of load power; typical values

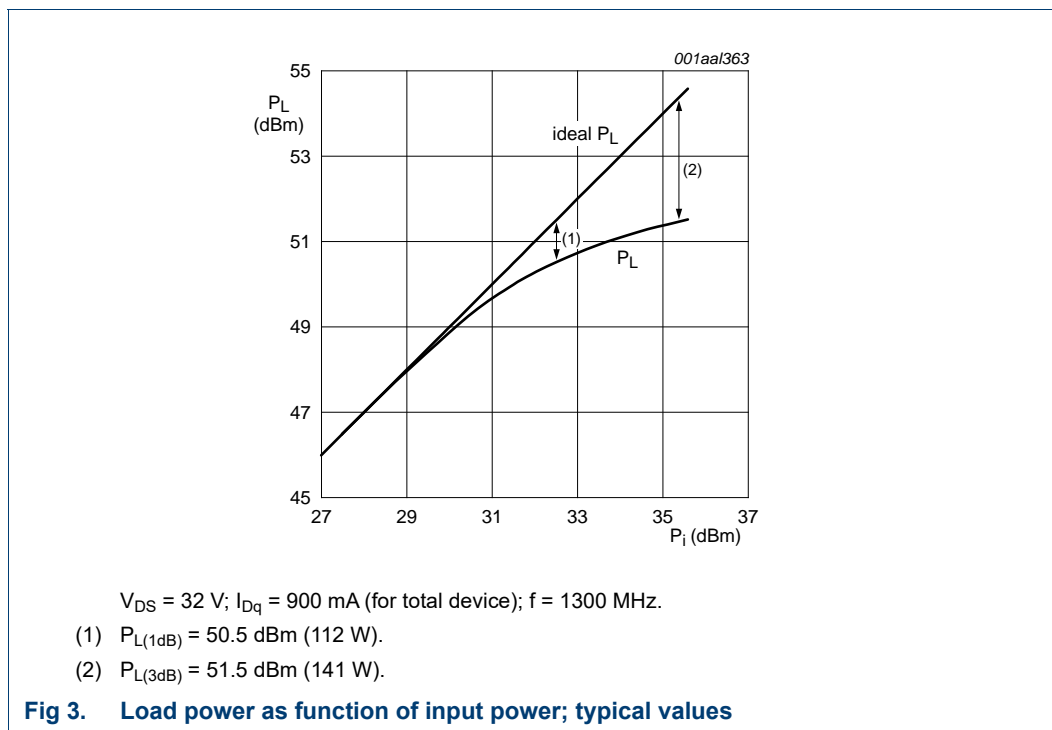

8.1.2 2-Tone CW

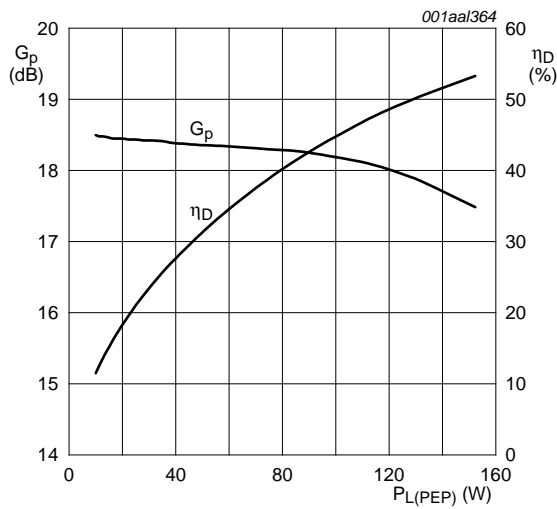

$V_{DS} = 32$ V; $I_{Dq} = 900$ mA (for total device);
 $f = 1300$ MHz; carrier spacing = 100 kHz.

Fig 4. Power gain and drain efficiency as function of peak envelope load power; typical values

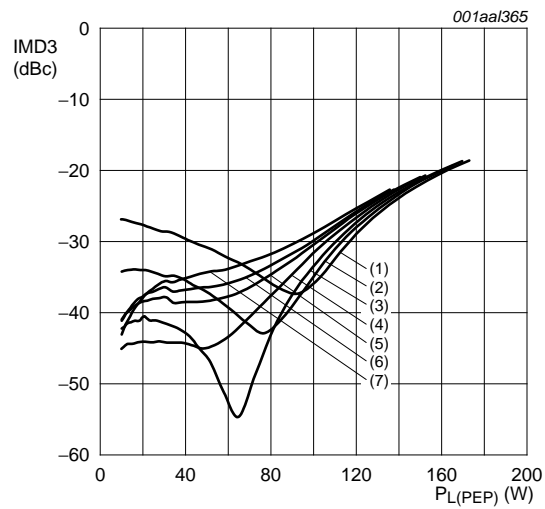

$V_{DS} = 32$ V; $f = 1300$ MHz; carrier spacing = 100 kHz.

- (1) $I_{Dq} = 200$ mA (for total device).
- (2) $I_{Dq} = 400$ mA (for total device).
- (3) $I_{Dq} = 600$ mA (for total device).
- (4) $I_{Dq} = 900$ mA (for total device).
- (5) $I_{Dq} = 1200$ mA (for total device).
- (6) $I_{Dq} = 1400$ mA (for total device).
- (7) $I_{Dq} = 1800$ mA (for total device).

Fig 5. Third order intermodulation distortion as a function of peak envelope load power; typical values

8.2 Reliability

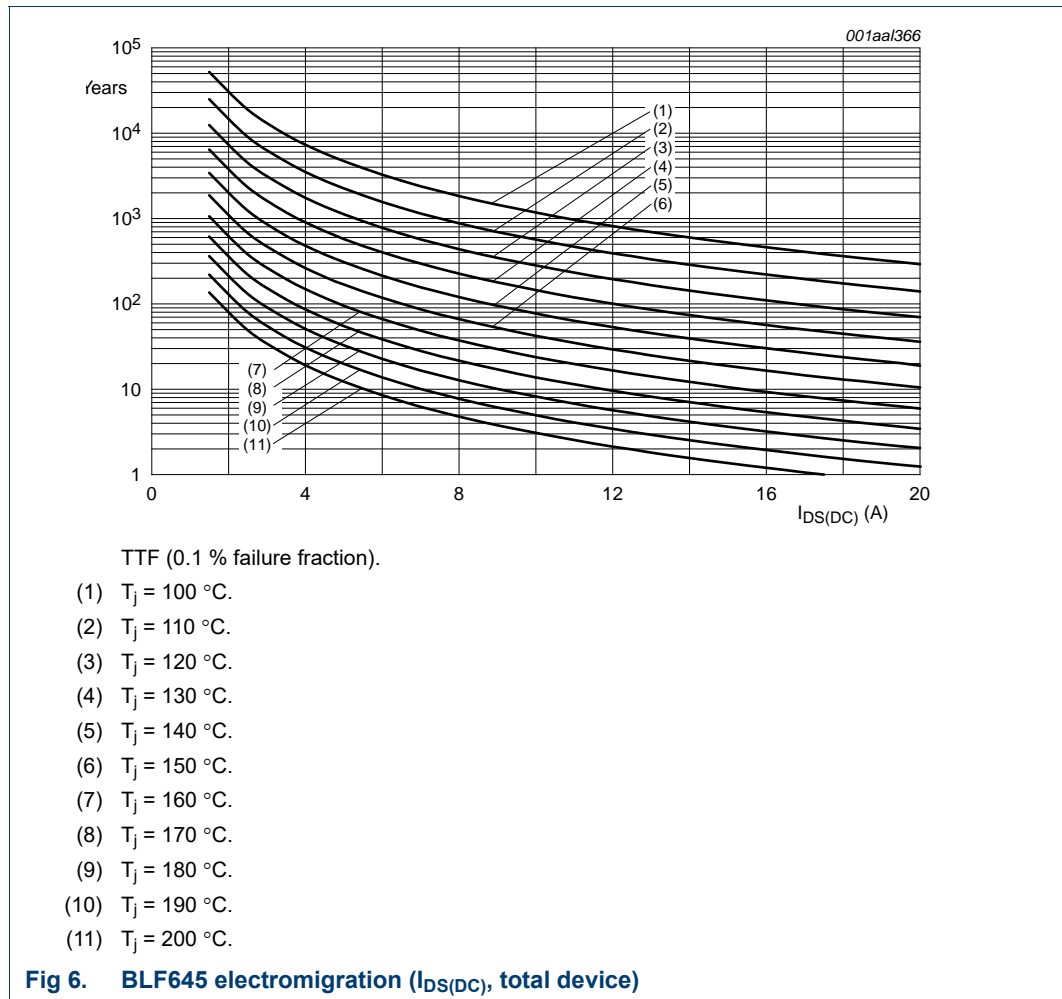

8.3 Test circuit

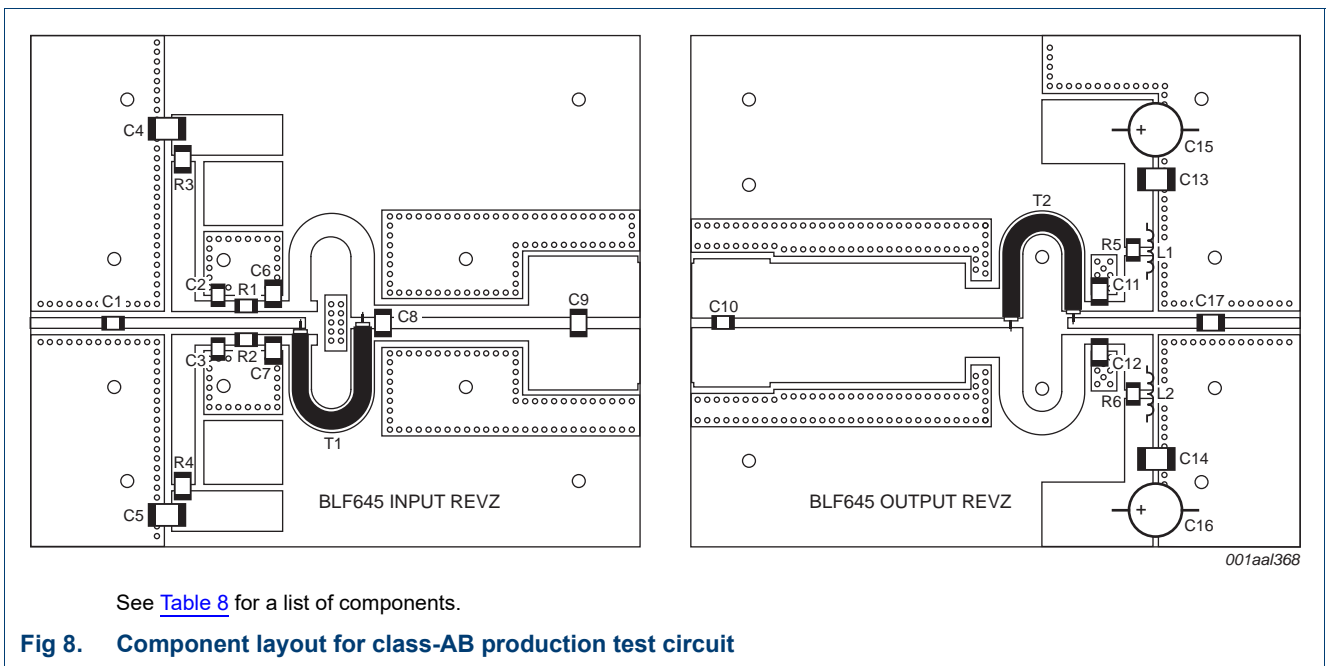
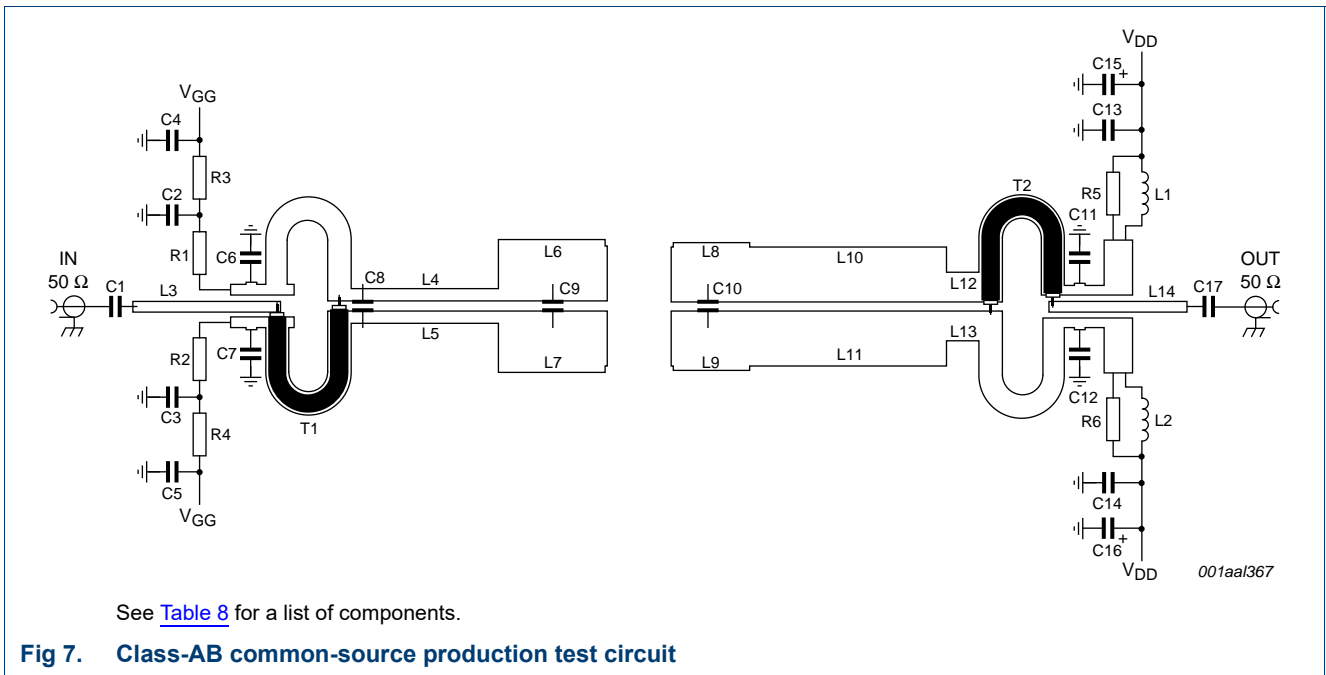

Table 8. List of components

For test circuit, see [Figure 7](#) and [Figure 8](#).

Component	Description	Value	Remarks
C1	multilayer ceramic chip capacitor	47 pF	[1]
C6, C7, C11, C12, C17	multilayer ceramic chip capacitor	27 pF	[2]
C2, C3	multilayer ceramic chip capacitor	100 nF	Murata X7R or equivalent
C4, C5, C13, C14	multilayer ceramic chip capacitor	4.7 μ F	TDK C4532X7R1E475MT020U or capacitor of same quality.
C8	multilayer ceramic chip capacitor	1.5 pF	[2]
C9	multilayer ceramic chip capacitor	3.3 pF	[2]
C10	multilayer ceramic chip capacitor	6.2 pF	[3]
C15, C16	electrolytic capacitor	220 μ F	TDK C4532X7R1E475MT020U or capacitor of same quality.
L1, L2	4 turns, 0.8 mm enameled copper wire	D = 3.5 mm; length = 4 mm	
L3	microstrip	-	[4] (W \times L) 1.67 mm \times 19.17 mm
L4, L5	microstrip	-	[4] (W \times L) 1.9 mm \times 23.7 mm
L6, L7	microstrip	-	[4] (W \times L) 9.6 mm \times 17.3 mm
L8, L9	microstrip	-	[4] (W \times L) 9 mm 12 mm
L10, L11	microstrip	-	[4] (W \times L) 8.5 mm \times 31.0 mm
L12, L13	microstrip	-	[4] (W \times L) 4.52 mm \times 5.0 mm
L14	microstrip	-	[4] (W \times L) 1.67 mm \times 21.67 mm
R1, R2	SMD resistor	11 Ω	1206
R3, R4	SMD resistor	1 k Ω	1206
R5, R6	SMD resistor	12 Ω	1206
T1, T2	semi rigid coax	Z = 50 Ω ; length = 34 mm	

[1] American technical ceramics type 100A or capacitor of same quality.

[2] American technical ceramics type 100B or capacitor of same quality.

[3] American technical ceramics type 180R or capacitor of same quality.

[4] Printed-Circuit Board (PCB): Taconic RF35; $\epsilon_r = 3.5$ F/m; height = 0.79 mm; Cu (top/bottom metallization); thickness copper plating = 35 μ m.

9. Package outline

Flanged balanced ceramic package; 2 mounting holes; 4 leads

SOT540A

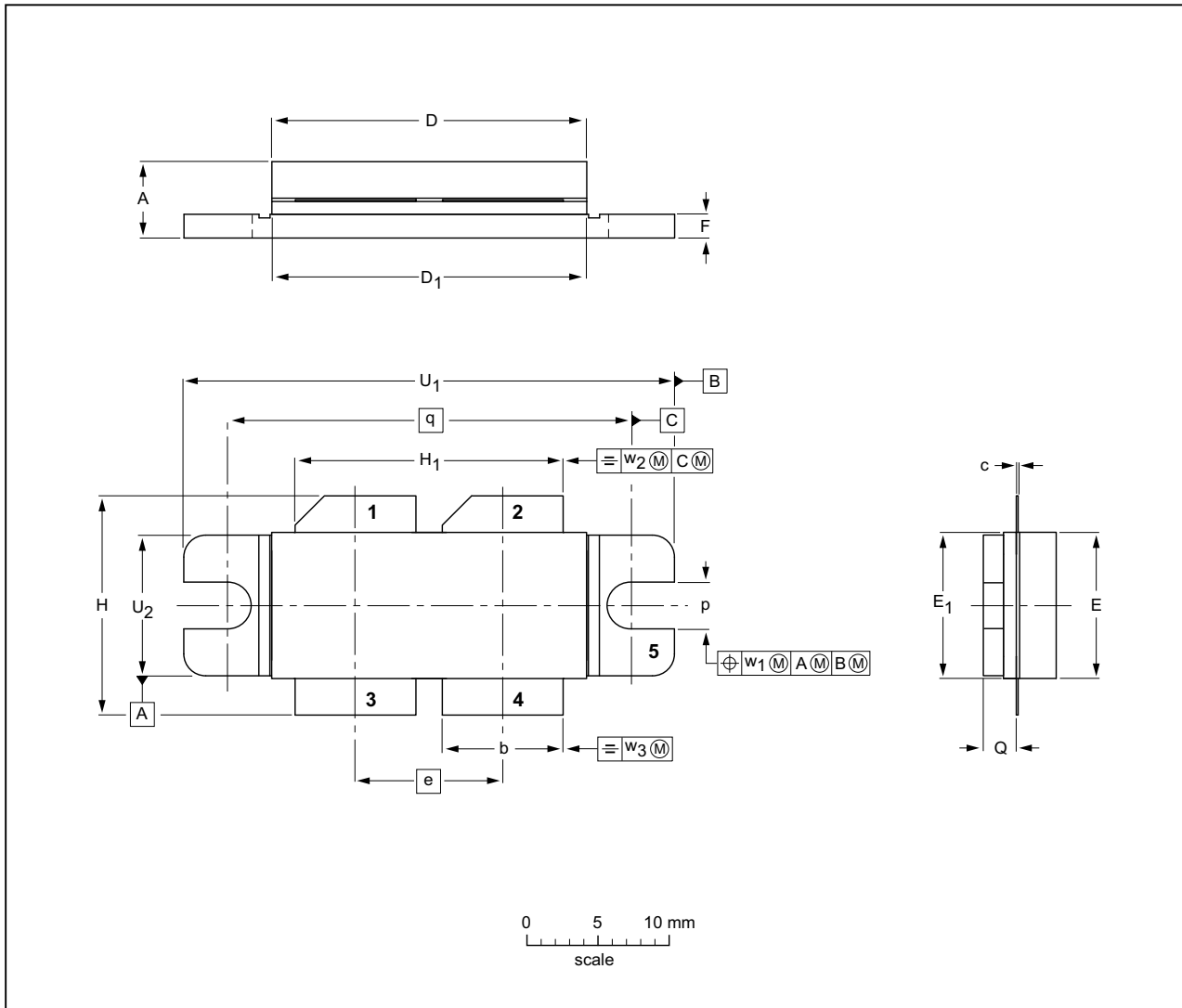

DIMENSIONS (millimetre dimensions are derived from the original inch dimensions)

UNIT	A	b	c	D	D ₁	e	E	E ₁	F	H	H ₁	p	Q	q	U ₁	U ₂	w ₁	w ₂	w ₃
mm	5.77 5.00	8.51 8.26	0.15 0.10	22.05 21.64	22.05 21.64	10.21	10.26 10.06	10.31 10.01	1.78 1.52	15.75 14.73	18.72 18.47	3.38 3.12	2.72 2.46	27.94	34.16 33.91	9.91 9.65	0.25	0.51	0.25
inches	0.227 0.197	0.335 0.325	0.006 0.004	0.868 0.852	0.868 0.852	0.402	0.404 0.396	0.406 0.394	0.070 0.060	0.620 0.580	0.737 0.727	0.133 0.123	0.107 0.097	1.100	1.345 1.335	0.390 0.380	0.010	0.020	0.010

OUTLINE VERSION	REFERENCES				EUROPEAN PROJECTION	ISSUE DATE
	IEC	JEDEC	EIAJ			
SOT540A						-99-12-28- 12-05-02

Fig 9. Package outline SOT540A

10. Abbreviations

Table 9. Abbreviations

Acronym	Description
CW	Continuous Waveform
DC	Direct Current
D-MOS	Diffusion Metal-Oxide Semiconductor
ESD	ElectroStatic Discharge
HF	High Frequency
LDMOS	Laterally Diffused Metal Oxide Semiconductor
LDMOST	Laterally Diffused Metal-Oxide Semiconductor Transistor
RF	Radio Frequency
SMD	Surface-Mount Device
VSWR	Voltage Standing-Wave Ratio

11. Revision history

Table 10. Revision history

Document ID	Release date	Data sheet status	Change notice	Supersedes
BLF645#2	20150901	Product data sheet	-	BLF645_1
Modifications:	<ul style="list-style-type: none"> The format of this document has been redesigned to comply with the new identity guidelines of Ampleon. Legal texts have been adapted to the new company name where appropriate. 			
BLF645_1	20100127	Product data sheet	-	-

12. Legal information

12.1 Data sheet status

Document status ^{[1][2]}	Product status ^[3]	Definition
Objective [short] data sheet	Development	This document contains data from the objective specification for product development.
Preliminary [short] data sheet	Qualification	This document contains data from the preliminary specification.
Product [short] data sheet	Production	This document contains the product specification.

[1] Please consult the most recently issued document before initiating or completing a design.

[2] The term 'short data sheet' is explained in section "Definitions".

[3] The product status of device(s) described in this document may have changed since this document was published and may differ in case of multiple devices. The latest product status information is available on the Internet at URL <http://www.ampleon.com>.

12.2 Definitions

Draft — The document is a draft version only. The content is still under internal review and subject to formal approval, which may result in modifications or additions. Ampleon does not give any representations or warranties as to the accuracy or completeness of information included herein and shall have no liability for the consequences of use of such information.

Short data sheet — A short data sheet is an extract from a full data sheet with the same product type number(s) and title. A short data sheet is intended for quick reference only and should not be relied upon to contain detailed and full information. For detailed and full information see the relevant full data sheet, which is available on request via the local Ampleon sales office. In case of any inconsistency or conflict with the short data sheet, the full data sheet shall prevail.

Product specification — The information and data provided in a Product data sheet shall define the specification of the product as agreed between Ampleon and its customer, unless Ampleon and customer have explicitly agreed otherwise in writing. In no event however, shall an agreement be valid in which the Ampleon product is deemed to offer functions and qualities beyond those described in the Product data sheet.

12.3 Disclaimers

Limited warranty and liability — Information in this document is believed to be accurate and reliable. However, Ampleon does not give any representations or warranties, expressed or implied, as to the accuracy or completeness of such information and shall have no liability for the consequences of use of such information. Ampleon takes no responsibility for the content in this document if provided by an information source outside of Ampleon.

In no event shall Ampleon be liable for any indirect, incidental, punitive, special or consequential damages (including - without limitation - lost profits, lost savings, business interruption, costs related to the removal or replacement of any products or rework charges) whether or not such damages are based on tort (including negligence), warranty, breach of contract or any other legal theory.

Notwithstanding any damages that customer might incur for any reason whatsoever, Ampleon' aggregate and cumulative liability towards customer for the products described herein shall be limited in accordance with the *Terms and conditions of commercial sale* of Ampleon.

Right to make changes — Ampleon reserves the right to make changes to information published in this document, including without limitation specifications and product descriptions, at any time and without notice. This document supersedes and replaces all information supplied prior to the publication hereof.

Suitability for use — Ampleon products are not designed, authorized or warranted to be suitable for use in life support, life-critical or safety-critical systems or equipment, nor in applications where failure or malfunction of an

Ampleon product can reasonably be expected to result in personal injury, death or severe property or environmental damage. Ampleon and its suppliers accept no liability for inclusion and/or use of Ampleon products in such equipment or applications and therefore such inclusion and/or use is at the customer's own risk.

Applications — Applications that are described herein for any of these products are for illustrative purposes only. Ampleon makes no representation or warranty that such applications will be suitable for the specified use without further testing or modification.

Customers are responsible for the design and operation of their applications and products using Ampleon products, and Ampleon accepts no liability for any assistance with applications or customer product design. It is customer's sole responsibility to determine whether the Ampleon product is suitable and fit for the customer's applications and products planned, as well as for the planned application and use of customer's third party customer(s). Customers should provide appropriate design and operating safeguards to minimize the risks associated with their applications and products.

Ampleon does not accept any liability related to any default, damage, costs or problem which is based on any weakness or default in the customer's applications or products, or the application or use by customer's third party customer(s). Customer is responsible for doing all necessary testing for the customer's applications and products using Ampleon products in order to avoid a default of the applications and the products or of the application or use by customer's third party customer(s). Ampleon does not accept any liability in this respect.

Limiting values — Stress above one or more limiting values (as defined in the Absolute Maximum Ratings System of IEC 60134) will cause permanent damage to the device. Limiting values are stress ratings only and (proper) operation of the device at these or any other conditions above those given in the Recommended operating conditions section (if present) or the Characteristics sections of this document is not warranted. Constant or repeated exposure to limiting values will permanently and irreversibly affect the quality and reliability of the device.

Terms and conditions of commercial sale — Ampleon products are sold subject to the general terms and conditions of commercial sale, as published at <http://www.ampleon.com/terms>, unless otherwise agreed in a valid written individual agreement. In case an individual agreement is concluded only the terms and conditions of the respective agreement shall apply. Ampleon hereby expressly objects to applying the customer's general terms and conditions with regard to the purchase of Ampleon products by customer.

No offer to sell or license — Nothing in this document may be interpreted or construed as an offer to sell products that is open for acceptance or the grant, conveyance or implication of any license under any copyrights, patents or other industrial or intellectual property rights.

Export control — This document as well as the item(s) described herein may be subject to export control regulations. Export might require a prior authorization from competent authorities.

12.4 Trademarks

Notice: All referenced brands, product names, service names and trademarks are the property of their respective owners.

Any reference or use of any 'NXP' trademark in this document or in or on the surface of Ampleon products does not result in any claim, liability or entitlement vis-à-vis the owner of this trademark. Ampleon is no longer part of the NXP group of companies and any reference to or use of the 'NXP'

trademarks will be replaced by reference to or use of Ampleon's own Any reference or use of any 'NXP' trademark in this document or in or on the surface of Ampleon products does not result in any claim, liability or entitlement vis-à-vis the owner of this trademark. Ampleon is no longer part of the NXP group of companies and any reference to or use of the 'NXP' trademarks will be replaced by reference to or use of Ampleon's own trademarks.

13. Contact information

For more information, please visit:

<http://www.ampleon.com>

For sales office addresses, please visit:

<http://www.ampleon.com/sales>

14. Contents

1 **Product profile** 1

1.1 General description 1

1.2 Features 1

1.3 Applications 2

2 **Pinning information** 2

3 **Ordering information** 2

4 **Limiting values** 2

5 **Thermal characteristics** 2

6 **Characteristics** 3

7 **Application information** 3

7.1 Ruggedness in class-AB operation 3

8 **Test information** 4

8.1 RF performance 4

8.1.1 1-Tone CW 4

8.1.2 2-Tone CW 6

8.2 Reliability 7

8.3 Test circuit 8

9 **Package outline** 10

10 **Abbreviations** 11

11 **Revision history** 11

12 **Legal information** 12

12.1 Data sheet status 12

12.2 Definitions 12

12.3 Disclaimers 12

12.4 Trademarks 13

13 **Contact information** 13

14 **Contents** 14

Please be aware that important notices concerning this document and the product(s) described herein, have been included in section 'Legal information'.

© Ampleon The Netherlands B.V. 2015. All rights reserved.

For more information, please visit: <http://www.ampleon.com>
 For sales office addresses, please visit: <http://www.ampleon.com/sales>

Date of release: 1 September 2015
 Document identifier: BLF645#2

Looking for pricing, stock, or lifecycle information?

Click below to explore more details on WIN SOURCE:

- ⊖ [View BLF645,112 on WIN SOURCE](#)
- ⊖ [Ampleon USA Inc. Information](#)

Optimize Your Supply Chain with WIN SOURCE Solutions

- ✓ Global Sourcing Solution
- ✓ Obsolete Management
- ✓ Cost Control Management
- ✓ Shortage Management
- ✓ Alternative Solution
- ✓ Excess Inventory Management