



**THE DATASHEET OF  
BQ500511ARHAT**



# bq500511A Low Cost 5-V Wireless Power Transmitter Controller for WPC v1.2 A11 Transmitters

## 1 Features

- Digital Controller Compatible With Wireless Power Consortium (WPC) v1.2 A11 Specification
- Improved Demodulation Algorithms Provide Robust Communication in Noisy Environments
- Designed to be Used With bq50002A Analog Front End
  - Note: The bq500511A is Incompatible With the bq50002 Device if Foreign Object Detection is Required
- Suitable for WPC and Proprietary 5-V Wireless Power Transmitters
- Supports Received Power Up to 5 W
- Two Chip Solution Enables High Efficiency Transmitter Designs of >75%
- Ultra Low Standby Power, Even During Digital Ping (<30 mW)
- Dynamic Power Limiting (DPL)<sup>™</sup> Enables Operation From Inputs Sources With Limited Power
- System LED Indication of Charging State and Fault Status
- Accurate Foreign Object Detection Method (FOD) Prevents Heating of Objects Between Transmitter and Receiver Coils

## 2 Applications

- WPC Compliant Wireless Chargers for Smart Phones and Wearable Applications
- Proprietary Wireless Chargers
- Medical and Industrial Applications
- Car and Other Vehicle Accessories
- See [www.ti.com/wirelesspower](http://www.ti.com/wirelesspower) for More Information on TI's Wireless Power Solutions

### Simplified Schematic

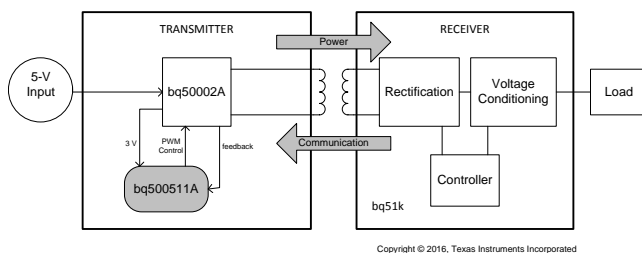

## 3 Description

The bq500511A is a wireless power transmitter controller that, when combined with the bq50002A analog front end (AFE) device, integrates all functions required to create a Qi-compliant or proprietary 5-V transmitter. The bq500511A and bq50002A together provide a compact wireless charger solution. The bq500511A pings the surrounding environment for the receiver devices to be powered, safely engages the device, receives packet communication from the powered device and manages the power transfer according to Wireless Power Consortium (WPC) v1.2 specification.

To maximize flexibility in wireless power control applications, Dynamic Power Limiting<sup>™</sup> (DPL) is featured on the bq500511A. DPL enhances user experience by seamlessly optimizing the usage of power available from limited input supplies.

The system supports Foreign Object Detection (FOD) by continuously monitoring the efficiency of the established power transfer, protecting from power lost due to metal objects misplaced in the wireless power transfer field. Should any abnormal condition develop during power transfer, the bq500511A handles the condition and provides indication outputs. Comprehensive status and fault monitoring features enable a low cost yet robust Qi-certified wireless power system design.

The bq500511A is available in a thermally enhanced 6 mm x 6 mm, 40-pin VQFN package.

### Device Information<sup>(1)</sup>

PART NUMBER	PACKAGE	BODY SIZE (NOM)
bq500511A	VQFN (40)	6.00 mm x 6.00 mm

(1) For all available packages, see the orderable addendum at the end of the data sheet.

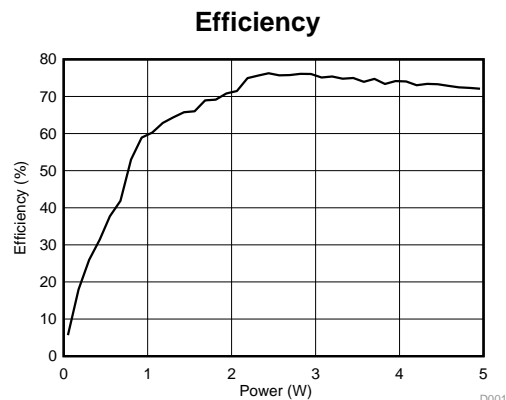

D001



## Table of Contents

<b>1 Features</b> .....	<b>1</b>	<b>8 Application and Implementation</b> .....	<b>14</b>
<b>2 Applications</b> .....	<b>1</b>	8.1 Application Information.....	14
<b>3 Description</b> .....	<b>1</b>	8.2 Typical Application .....	14
<b>4 Revision History</b> .....	<b>2</b>	<b>9 Power Supply Recommendations</b> .....	<b>18</b>
<b>5 Pin Configuration and Functions</b> .....	<b>3</b>	<b>10 Layout</b> .....	<b>18</b>
<b>6 Specifications</b> .....	<b>5</b>	10.1 Layout Guidelines .....	18
6.1 Absolute Maximum Ratings .....	5	10.2 Layout Examples.....	19
6.2 ESD Ratings.....	5	<b>11 Device and Documentation Support</b> .....	<b>22</b>
6.3 Recommended Operating Conditions.....	5	11.1 Device Support .....	22
6.4 Thermal Information .....	6	11.2 Documentation Support .....	22
6.5 Electrical Characteristics.....	6	11.3 Receiving Notification of Documentation Updates	22
6.6 Typical Characteristics.....	6	11.4 Community Resources.....	22
<b>7 Detailed Description</b> .....	<b>7</b>	11.5 Trademarks .....	22
7.1 Overview .....	7	11.6 Electrostatic Discharge Caution.....	22
7.2 Functional Block Diagram .....	7	11.7 Glossary .....	22
7.3 Feature Description.....	8	<b>12 Mechanical, Packaging, and Orderable</b>	
7.4 Device Functional Modes.....	12	<b>Information</b> .....	<b>23</b>

## 4 Revision History

DATE	REVISION	NOTES
August 2016	A	Initial release.

## 5 Pin Configuration and Functions

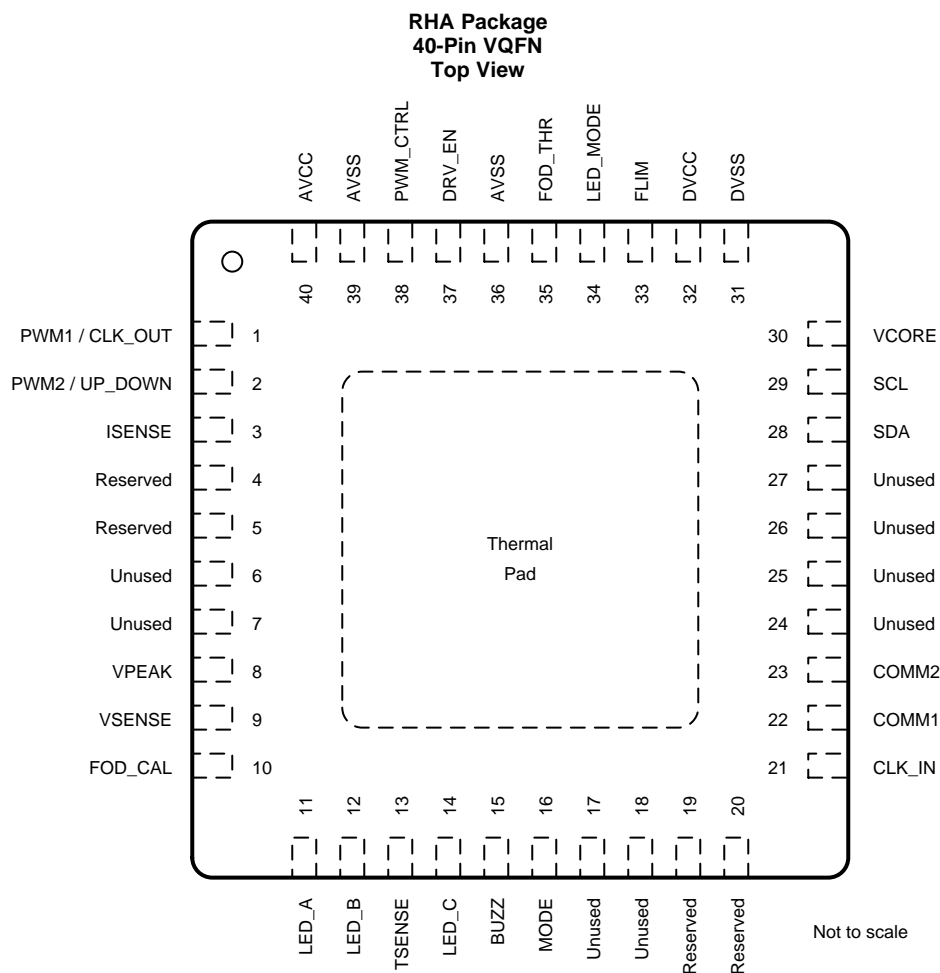

### Pin Functions

PIN		I/O	DESCRIPTION
NAME	NO.		
AVCC	40	—	Analog I power supply.
AVSS	36, 39	—	Analog ground.
BUZZ	15	O	DC buzzer output. A 400-ms DC pulse when charging begins. This could also be connected to an LED through a 1-k $\Omega$ resistor.
CLK_IN	21	I	CLK_OUT signal from the internal oscillator of the bq50002A Analog Front End.
COMM1	22	I	Communication channel 1. Typically generated by the bq50002A Analog Front End.
COMM2	23	I	Communication channel 2. Typically generated by the bq50002A Analog Front End.
DRV_EN	37	O	Driver enable.
DVCC	32	—	Digital power supply.
DVSS	31	—	Digital ground.
FLIM	33	I	Leave floating to conform to the WPC specification 205-kHz maximum operating frequency. Pull down with a 10-k $\Omega$ resistor to limit the maximum frequency to 190 kHz.
FOD_CAL	10	I	FOD calibration.
FOD_THR	35	I	FOD threshold.
ISENSE	3	I	Input current sense.
LED_A	11	O	Connect to a LED through a 1-k $\Omega$ resistor for status indication. Typically GREEN.

**Pin Functions (continued)**

PIN		I/O	DESCRIPTION
NAME	NO.		
LED_B	12	O	Connect to a LED through a 1-k $\Omega$ resistor for status indication. Typically RED.
LED_C	14	O	Connect to a LED through a 1-k $\Omega$ resistor for status indication. Typically ORANGE.
LED_MODE	34	I	LED mode selection.
MODE	16	O	MODE is an output intended for use by the bq50002A Analog Front End indicating whether adjustments should be made using frequency (when MODE is low) or duty-cycle (when MODE is high).
PWM1 / CLK_OUT	1	O	If PWM_CTRL is high, this pin outputs PWM1 signal. If PWM_CTRL is low, this pin outputs clock signal. The rising edge of the clock is used to adjust frequency (MODE low) or duty cycle (MODE high) output of the bq50002A Analog Front End.
PWM_CTRL	38	O	PWM_CTRL is an output intended for use by the bq50002A Analog Front End to select whether its PWM outputs are generated internally within the bq50002A itself (PWM_CTRL HIGH), or whether they are simply passed through from external signals (PWM_CTRL LOW).
PWM2 / UP_DOWN	2	O	If PWM_CTRL is high, this pin outputs PWM2 signal. If PWM_CTRL is low, this pin is used to adjust the frequency (MODE low) or duty cycle (MODE high) of the external PWM output. If this signal is high, it decrease frequency or increase duty cycle. If this signal is low, it increases frequency or decreases duty cycle output of the bq50002A Analog Front End.
Reserved	4	I	Leave this pin open.
Reserved	5	I	Unused
Reserved	19	I	Reserved. Leave this pin open.
Reserved	20	I/O	Reserved. Leave this pin open.
SCL	29	I/O	10-k $\Omega$ pull-up resistor to 3-V supply. I <sup>2</sup> C Clock.
SDA	28	I/O	10-k $\Omega$ pull-up resistor to 3-V supply. I <sup>2</sup> C Data.
TSENSE	13	I	Temperature sensing for safety shutdown. Connect to 3 V though 10-k $\Omega$ resistor if unused.
Unused	6	I	Leave this pin open.
Unused	7	I/O	Leave this pin open.
Unused	17, 18, 24, 25, 26, 27	I/O	Leave this pin open.
VCORE	30	—	Regulated internal core power supply. Connect through 0.4- $\mu$ F capacitor to ground.
VPEAK	8	I	Peak coil voltage.
VSENSE	9	I	Input voltage sense.

## 6 Specifications

### 6.1 Absolute Maximum Ratings

over operating free-air temperature range (unless otherwise noted)<sup>(1)</sup>

		MIN	MAX	UNIT
Voltage	Applied at VCC to VSS	-0.3	4.1	V
	Applied to any pin (excluding V <sub>CORE</sub> ) <sup>(2)</sup>	-0.3	VCC + 0.3	V
Diode current at any device pin		-2	2	mA
Maximum junction temperature, T <sub>J</sub>			95 <sup>(3)</sup>	°C
Storage temperature, T <sub>stg</sub>		-55	95	°C

- (1) Stresses beyond those listed under *Absolute Maximum Ratings* may cause permanent damage to the device. These are stress ratings only, which do not imply functional operation of the device at these or any other conditions beyond those indicated under *Recommended Operating Conditions*. Exposure to absolute-maximum-rated conditions for extended periods may affect device reliability.
- (2) All voltages referenced to V<sub>SS</sub>. V<sub>CORE</sub> is for internal device use only. No external DC loading or voltage should be applied.
- (3) It is recommended to follow the current JEDEC J-STD-020 specification with peak reflow temperatures not higher than classified on the device label on the shipping boxes or reels. In general, hand soldering is not recommended. However, if hand soldering is required for application prototyping, peak temperature must not exceed 250°C for longer than 30 seconds durations. In addition, during storage, the maximum storage temperature of 95°C should not be exceeded.

### 6.2 ESD Ratings

		VALUE	UNIT
V <sub>(ESD)</sub>	Electrostatic discharge	Human-body model (HBM), per ANSI/ESDA/JEDEC JS-001 <sup>(1)</sup>	1000
		Charged-device model (CDM), per JEDEC specification JESD22-C101 <sup>(2)</sup>	250

- (1) JEDEC document JEP155 states that 500-V HBM allows safe manufacturing with a standard ESD control process.
- (2) JEDEC document JEP157 states that 250-V CDM allows safe manufacturing with a standard ESD control process.

### 6.3 Recommended Operating Conditions

over operating free-air temperature range (unless otherwise noted)

		MIN	NOM	MAX	UNIT
V <sub>CC</sub>	Supply voltage during program execution and FRAM programming (AVCC = DVCC) <sup>(1)</sup>	2		3.6	V
V <sub>SS</sub>	Supply voltage (AVSS = DVSS)		0		V
T <sub>A</sub>	Operating free-air temperature	-40		85	°C
T <sub>J</sub>	Operating free-air temperature	-40		85	°C
C <sub>(V<sub>CORE</sub>)</sub>	Required capacitor at V <sub>CORE</sub> <sup>(2)</sup>		470		nF
C <sub>(V<sub>CC</sub>)/C<sub>(V<sub>CORE</sub>)</sub></sub>	Capacitor ratio of VCC to V <sub>CORE</sub>	10			nF

- (1) TI recommends to power AVCC and DVCC from the same source. A maximum difference of 0.3 V between AVCC and DVCC can be tolerated during power up and operation.
- (2) A capacitor tolerance of ±20% or better is required.

## 6.4 Thermal Information

THERMAL METRIC <sup>(1)</sup>		bq500511A	UNIT
		RHA (VQFN)	
		40 PINS	
$R_{\theta JA}$	Junction-to-ambient thermal resistance	31.8	°C/W
$R_{\theta JC(top)}$	Junction-to-case (top) thermal resistance	18.5	°C/W
$R_{\theta JB}$	Junction-to-board thermal resistance	6.8	°C/W
$\Psi_{JT}$	Junction-to-top characterization parameter	0.2	°C/W
$\Psi_{JB}$	Junction-to-board characterization parameter	6.7	°C/W
$R_{\theta JC(bot)}$	Junction-to-case (bottom) thermal resistance	1.8	°C/W

(1) For more information about traditional and new thermal metrics, see the [Semiconductor and IC Package Thermal Metrics](#) application report.

## 6.5 Electrical Characteristics

over operating free-air temperature range (unless otherwise noted)

PARAMETER		TEST CONDITIONS	MIN	TYP	MAX	UNIT	
$I_{(AM)}$	Active Mode Supply Current into $V_{CC}$	3 V		3.45	4.3	mA	
$I_{(LPM)}$	Low-Power Mode Supply Current into $V_{CC}$	3 V	-40°C		274	$\mu$ A	
			25°C		285	340	$\mu$ A
			60°C		315		$\mu$ A
			85°C		340	455	$\mu$ A

## 6.6 Typical Characteristics

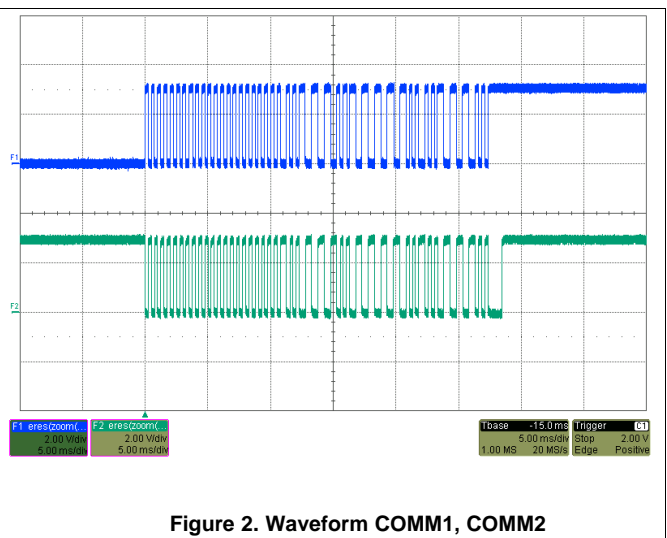
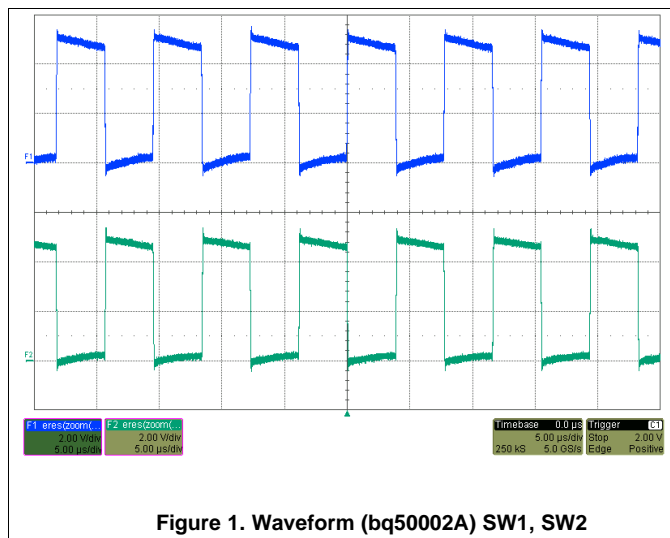

## 7 Detailed Description

### 7.1 Overview

The principle of wireless power transfer is simply an open-cored transformer consisting of transmitter and receiver coils. The transmitter coil and electronics are typically built into a charger pad and the receiver coil and electronics are typically built into a portable device, such as a cell phone. When the receiver coil is positioned on the transmitter coil, magnetic coupling occurs when the transmitter coil is driven. The flux is coupled into the secondary coil, which induces a voltage and current flows. The secondary voltage is rectified, and power can be transferred effectively to a load, wirelessly. Power transfer can be managed through various closed loop control schemes.

After power is applied and the transmitter device comes out of reset, it will automatically begin the process of detecting and powering a receiver. The bq500511A sends a ping to detect the presence of a receiver on the pad. After a receiver is detected, the bq500511A attempts to establish communication and begin power transfer. The bq500511A is designed to operate with the bq50002A Wireless Power Transmitter Analog Front End to control a full-bridge power stage to drive the primary coil. Through a simple interface the bq500511A instructs the bq50002A how much to increase or decrease power. The full bridge power stage allows for higher power delivery for a given supply voltage.

### 7.2 Functional Block Diagram

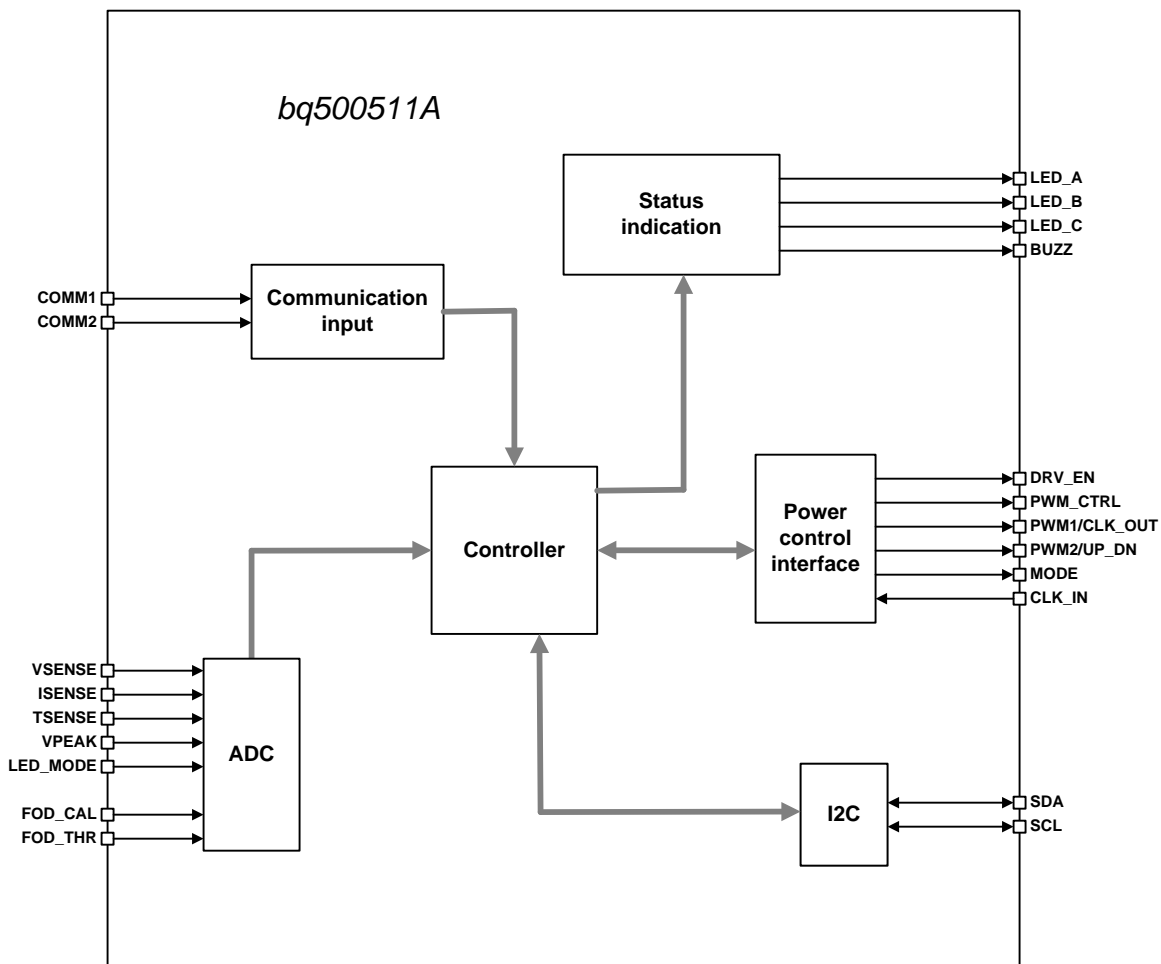

Copyright © 2016, Texas Instruments Incorporated

## 7.3 Feature Description

### 7.3.1 A11 Coil Specification

The bq500511A controller supports the A11 transmitter coil type for which the coil and matching capacitor specification has been established by the WPC Standard although the device can be used in a proprietary (non-WPC) system. This is fixed and cannot be changed on the transmitter side.

For a current list of coil vendors, see *bqTESLA Transmitter Coil Vendors*, [SLUA649](#).

### 7.3.2 Option Select Pins

There are three option select pins on the bq500511A. Two (FOD\_CAL and FOD\_THR) are used to calibrate the foreign object detection algorithm. The third (LED\_MODE) selects the LED output behavior. The voltages on these pins will be read by bq500511A at power-up.

For LED\_MODE, the selected bin determines the LED behavior based on [Table 1](#).

See section [Foreign Object Detection \(FOD\) and FOD Calibration](#) for more information on the remaining option select pins.

### 7.3.3 LED Modes

The bq500511A can directly drive three LED outputs (pin 11, pin 12, and pin 14) through a simple current limit resistor (typically 470  $\Omega$ ), based on the mode selected. The three current limit resistors can be individually adjusted to tune or match the brightness of the LEDs. Do not exceed the maximum output current rating of the device.

Several predefined LED display schemes are selectable through the voltage on the LED\_MODE pin at startup. Any means of setting the LED\_MODE voltage can be used; if a resistor divider between 3 V and ground is used as shown in [Figure 3](#), relatively large values should be used to minimize the idle power loss. With 100 k $\Omega$  used for the upper resistor values for the lower resistor, R<sub>LED</sub> selects one of the desired LED indication schemes presented in [Table 1](#).

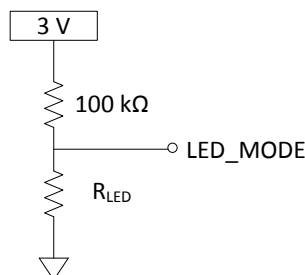

**Figure 3. LED\_MODE Selection**

**Table 1. LED Control**

LED CONTROL OPTION	R <sub>LED</sub> SELECTION RESISTOR (k $\Omega$ )	DESCRIPTION	LED	OPERATIONAL STATES					
				STANDBY	POWER TRANSFER <sup>(1)</sup>	CHARGE COMPLETE	FAULT <sup>(1)(2)</sup>	FOD WARNING <sup>(2)</sup>	DPL <sup>(1)</sup>
1	24.9	2-LED option #1	LED_A (green)	off	blink slow	on	off	off	blink slow
			LED_B (red)	off	off	off	on	blink fast	blink slow
			LED_C (orange)	–	–	–	–	–	–
2	36.5	2-LED option Standby LED's	LED_A (green)	on	blink slow	on	off	off	blink slow
			LED_B (red)	on	off	off	on	blink fast	blink slow
			LED_C (orange)	–	–	–	–	–	–
3	49.9	Single LED option	LED_A (green)	off	on	off	blink fast	on	on
			LED_B (red)	–	–	–	–	–	–
			LED_C (orange)	–	–	–	–	–	–

(1) blink slow = 1.25 Hz

(2) blink fast = 5 Hz

**Feature Description (continued)**
**Table 1. LED Control (continued)**

LED CONTROL OPTION	R <sub>LED</sub> SELECTION RESISTOR (kΩ)	DESCRIPTION	LED	OPERATIONAL STATES					
				STANDBY	POWER TRANSFER <sup>(1)</sup>	CHARGE COMPLETE	FAULT <sup>(1)(2)</sup>	FOD WARNING <sup>(2)</sup>	DPL <sup>(1)</sup>
4	66.5	2-LED option #2	LED_A (green)	off	on	off	off	off	–
			LED_B (red)	off	off	off	on	blink fast	blink slow
			LED_C (orange)	–	–	–	–	–	–
5	86.6	3-LED option #1	LED_A (green)	off	off	on	off	off	
			LED_B (red)	off	on	off	on	on	on
			LED_C (orange)	off	off	off	off	off	off
6	113	3-LED option #2	LED_A (green)	off	blink slow	on	off	off	off
			LED_B (red)	off	off	off	on	blink fast	off
			LED_C (orange)	off	off	off	off	off	blink slow
7	147	3-LED option #3	LED_A (green)	off	blink slow	off	off	off	off
			LED_B (red)	off	off	on	off	off	off
			LED_C (orange)	off	off	off	on	blink fast	blink slow
8	200	2-LED option #3	LED_A (green)	off	off	on	blink slow	off	off
			LED_B (red)	off	on	off	blink slow	on	on
			LED_C (orange)	–	–	–	–	–	–
9	274	2-LED option #4	LED_A (green)	off	blink slow	on	off	off	blink slow
			LED_B (red)	off	off	off	on	blink fast	blink slow
			LED_C (orange)	–	–	–	–	–	–
10	392	2-LED option #5	LED_A (green)	off	on	off	blink fast	on	blink slow
			LED_B (red)	off	off	on	off	off	off
			LED_C (orange)	–	–	–	–	–	–

**7.3.4 Foreign Object Detection (FOD) and FOD Calibration**

The bq500511A supports FOD in order to meet the requirements of the WPC v1.2 specification and to protect against the heating of metal objects between coils. Continuously monitoring input power, known losses, and the value of power reported by the receiver device being charged, the bq500511A can estimate how much power is unaccounted for and presumed lost due to metal objects placed in the wireless power transfer path. If this unexpected loss exceeds the threshold set by the FOD resistors, a fault is indicated and power transfer is halted.

As the default, the FOD resistors should set a threshold of 400 mW which has been empirically determined using standard WPC FOD test objects (disc, ring and foil). Some tuning might be required as every system will be slightly different. This tuning is best done by trial and error: increase or decrease the loss threshold and retry the system with the standard test objects. The ultimate goal of the FOD feature is safety; to protect misplaced metal objects from becoming hot. Reducing the loss threshold and making the system too sensitive may lead to a false object detection and a bad user experience. Find the balance which best suits the application.

If the application requires disabling FOD, it is possible by tying the FOD\_THR pin to 3 V.

---

**NOTE**

Disabling FOD results in a TX solution that is not WPC v1.2 compliant.

---

The FOD\_CAL input, can be used to compensate for any load-dependent effect on the power loss. Using a calibrated FOD reference receiver with no foreign objects present, FOD\_CAL should be selected such that the calculated loss across the load range is substantially constant (within approximately 100 mW). After correcting for the load dependence, the FOD thresholds should be re-set above the resulting average by approximately 400 mW for the transmitter to satisfy the WPC requirements on tolerated heating.

Similarly to the LED\_MODE selection, FOD\_THR and FOD\_CAL are set based on the voltage of their inputs (pins 35 and 10 respectively) measured when the device is powered up.

$$\text{FOD\_threshold} = \text{FOD\_THR} \times 400 \quad (1)$$

Where:

FOD\_threshold is the maximum allowed loss in mW, above which a FOD fault is triggered.

FOD\_THR is the voltage on pin 35 in volts (between 0 and 2.5 Volts).

For example, to set the recommended starting threshold of 400 mW, 1 V should be applied to FOD\_THR; this could be accomplished with a resistor divider between 3 V and ground consisting of 200 kΩ over 100 kΩ.

The value for FOD\_CAL is calculated with an offset to allow a correction which either increases or decreases with load.

$$\text{FOD\_correction} = -1000 + \text{FOD\_CAL} \times 800 \quad (2)$$

Where:

FOD\_correction is load dependent correction in mW/Amp.

FOD\_CAL is the voltage on pin 10 in volts (between 0 and 2.5 Volts).

For both the FOD\_THR and FOD\_CAL inputs, an internal analog to digital converter with a range of 0 V – 2.5 V is used to measure the input. The combined range and gain provide attainable ranges of 0 mW to 1000 mW for FOD\_threshold, and –1000 mW/A to +1000 mW/A for FOD\_correction.

**Contact TI for the TX tuning tool to set appropriate FOD\_THR and FOD\_CAL values for your design.**

### 7.3.5 Shut Down Through External Thermal Sensor or Trigger

Typical applications of the bq500511A do not require additional thermal protection. This shutdown feature is provided for enhanced applications and is not limited to thermal shutdown. The key parameter is the 1 V threshold on pin 13, TSENSE. Voltage below 1 V on pin 13 causes the device to shut down. The application of thermal monitoring through a negative temperature coefficient (NTC) sensor, for example, is straightforward. The NTC forms the lower leg of a temperature-dependent voltage divider. The NTC leads are connected to the bq500511A device, pin 13 and GND. The threshold on pin 13 is set to 1 V, below which the system shuts down and indicates a fault (indication depending on LED mode chosen).

To implement this feature follow these steps:

1. Consult the NTC data sheet and find the resistance versus temperature curve.
2. Determine the actual temperature where the NTC will be placed by using a thermal probe.
3. Read the NTC resistance at that temperature in the NTC datasheet, that is R\_NTC.
4. Use the following formula to determine the upper leg resistor (R\_Setpoint):

$$\text{R\_Setpoint} = 2.3 \times \text{R\_NTC} \quad (3)$$

The system restores normal operation after approximately five minutes or if the receiver is removed. If the feature is not used, this pin must be pulled high.

---

#### NOTE

Pin 13, TSENSE, must always be terminated; otherwise, erratic behavior may occur.

---

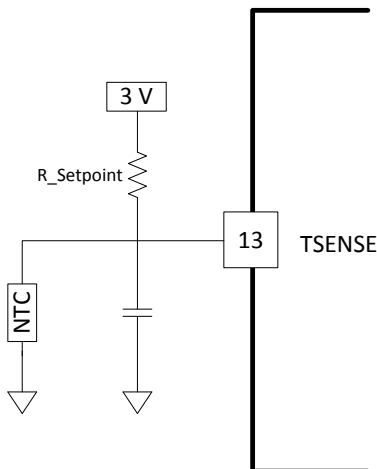

Figure 4. NTC Application (optional)

### 7.3.6 Fault Handling and Indication

Table 2 shows end power transfer (EPT) packet responses, fault conditions, and the duration of how long the condition lasts until a retry is attempted. The LED mode selected determines how the LED indicates the condition or fault.

Table 2. Fault Handling and Indication

CONDITION	DURATION <sup>(1)</sup> (before retry)	COMMENTS IMMEDIATE <sup>(2)</sup>
EPT-00		unknown
EPT-01	5 seconds	charge complete
EPT-02	Infinite	internal fault
EPT-03	5 minutes	over temperature
EPT-04	Immediate	over voltage
EPT-05	Immediate	over current
EPT-06	Infinite	battery failure
EPT-07	Not applicable	reconfigure
EPT-08	Immediate	no response
OVP	Immediate	TX over voltage
NTC	5 minutes	TX over temperature
FOD warning	12 seconds	buzzer and LED
FOD trip	5 minutes	same as over temp

(1) After a FAULT, the magnetic field is re-characterized to improve the ability to detect the removal of the at-fault receiver. If the receiver is removed in the first second immediately following the detection of this fault (before the re-characterization is complete), the field corresponding to an empty pad may be associated with the faulty receiver and the LED indication may continue to indicate a fault state even though no receiver is present. This indication persists until either the HOLDOFF time expires or a new receiver disturbs the field, at which time normal operation, with proper LED indication, is resumed.

(2) "Immediate" is less than 1 second.

### 7.3.7 Power Transfer Start Signal

The bq500511A provides an output signal to indicate that power transfer has begun. Pin 15, BUZZ, outputs a 400-ms duration, 4-kHz square wave appropriate to drive a low cost AC type ceramic buzzers. If not used, this pin should be left open.

### 7.3.8 Power-On Reset

The bq500511A has an integrated power-on reset (POR) circuit which monitors the supply voltage and handles the correct device startup sequence. Additional supply voltage supervisor or reset circuits are not needed.

### 7.3.9 Trickle Charge and CS100

The WPC specification provides an EPT message (EPT-01) to indicate charge complete. Upon receipt of the charge complete message, the bq500511A disables the output and changes the LED indication. The exact indication depends on the LED\_MODE chosen. In some battery charging applications, there is a benefit to continue the charging process in trickle-charge mode to top off the battery. The WPC specification provides for an informational 'Charge Status' packet that conveys the level of battery charger. The bq500511A uses this command to enable top-off charging. The bq500511A changes the LED indication to reflect charge complete when a Charge Status message indicating 100% is received, but unlike the response to an EPT, it will not halt power transfer even though the LED indicates charge complete. The mobile device can use a CS100 packet to enable trickle charge mode. If the reported charge status drops below 90%, normal charging indication is resumed.

## 7.4 Device Functional Modes

### 7.4.1 Power Transfer

Power transfer efficiency and robustness depends on coil coupling. Coupling depends on the distance between coils, alignment, coil dimensions, coil materials, number of turns, magnetic shielding, impedance matching, frequency, and duty cycle. Most importantly, the receiver and transmitter coils must be aligned for best coupling and efficient power transfer. The smaller the space between the coils is, the better the coupling. Shielding is added as a backing to both the transmitter and receiver coils to direct the magnetic field to the coupled zone. Magnetic fields outside the coupled zone do not transfer power. Thus, shielding also serves to contain the fields to avoid coupling to other adjacent system components.

Regulation can be achieved by controlling any one of the coil coupling parameters. However, for WPC compatibility, the transmitter-side coils and capacitance are specified and the resonant frequency point is fixed. Power transfer is regulated by changing the operating frequency between 110 kHz to 205 kHz. The higher the frequency, the further from resonance and the lower the power. Duty cycle remains constant at 50% throughout the power band and is reduced only once 205 kHz is reached.

#### 7.4.1.1 Dynamic Power Limiting™

Dynamic Power Limiting™ (DPL) allows operation from a 5-V supply with limited current capability (such as a USB port). When the input voltage is observed drooping, the output power is dynamically limited to reduce the load and provides margin relative to the supply's capability.

Anytime the DPL control loop is regulating the operating point of the transmitter, the LED will indicate that DPL is active. The LED color and flashing pattern are determined by the LED Table. If the receiver sends a Control Error Packet (CEP) with a negative value, (for example, to reduce power to the load), the bq500511A in DPL mode will return to normal operation and respond to this CEP through the standard WPC control loop behavior.

#### 7.4.1.2 Operating Frequency Limiting

Pin-33, FLIM, can be used to set an upper operating frequency limit of 190 kHz by pulling down with a 10-kΩ resistor. Regulatory bodies in some countries have proposed that wireless power transmitters limit operation at this point. While not required anywhere today, this forward looking option provides the means for a simple design modification to address that possible future requirement. A weak internal pull-up allows normal operation without any applied bias.

Note that this feature may prevent WPC certification.

### 7.4.2 Communication

Communication within the WPC v1.2 specification is from the receiver to the transmitter. For example, in order to regulate the output of the transmitter, the receiver sends messages requesting the transmitter to increase or decrease power. The receiver communicates by modulating the rectifier voltage and using amplitude modulation (AM) sends packets of information to the transmitter. A packet is comprised of a preamble, a header, the actual message, and a checksum, as defined by the WPC standard.

### Device Functional Modes (continued)

The receiver sends a packet by modulating an impedance network. This AM signal reflects back as a change in the voltage amplitude on the transmitter coil. In the bq500511A and bq50002A system, the bq50002A performs the demodulation function and passes a digitized version of the message to the bq500511A where the message is decoded and processed. For example in response to a Control Error Packet, the bq500511A calculates the required change in output power and in turn controls the bq50002A through the CLK\_OUT, UP\_DOWN, and MODE pins to adjust the operating point and thus its output power.

The modulation impedance network on the receiver can either be resistive or capacitive. Figure 5 shows the resistive modulation approach, where a resistor is periodically added to the load, resulting in an amplitude change in the transmitter voltage. Figure 6 shows the corresponding capacitive modulation approach.

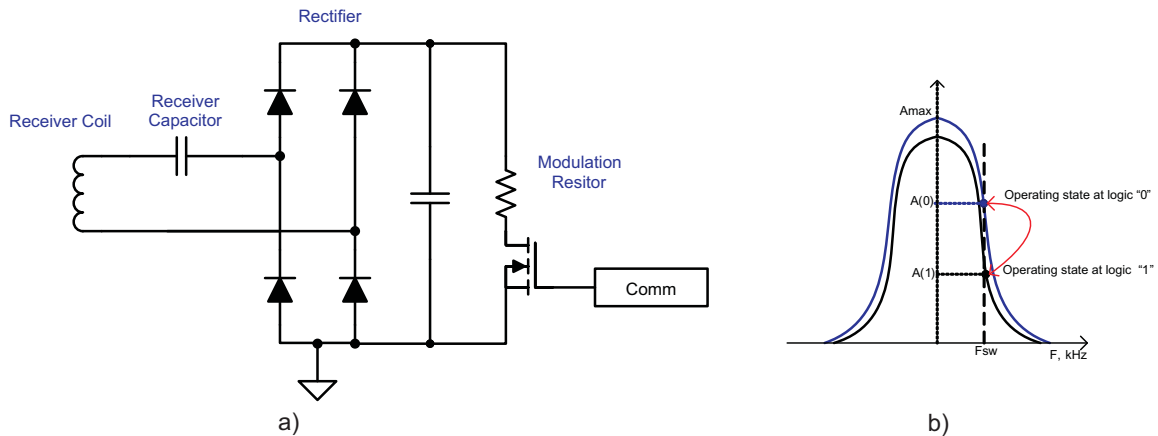

Figure 5. Receiver Resistive Modulation Circuit

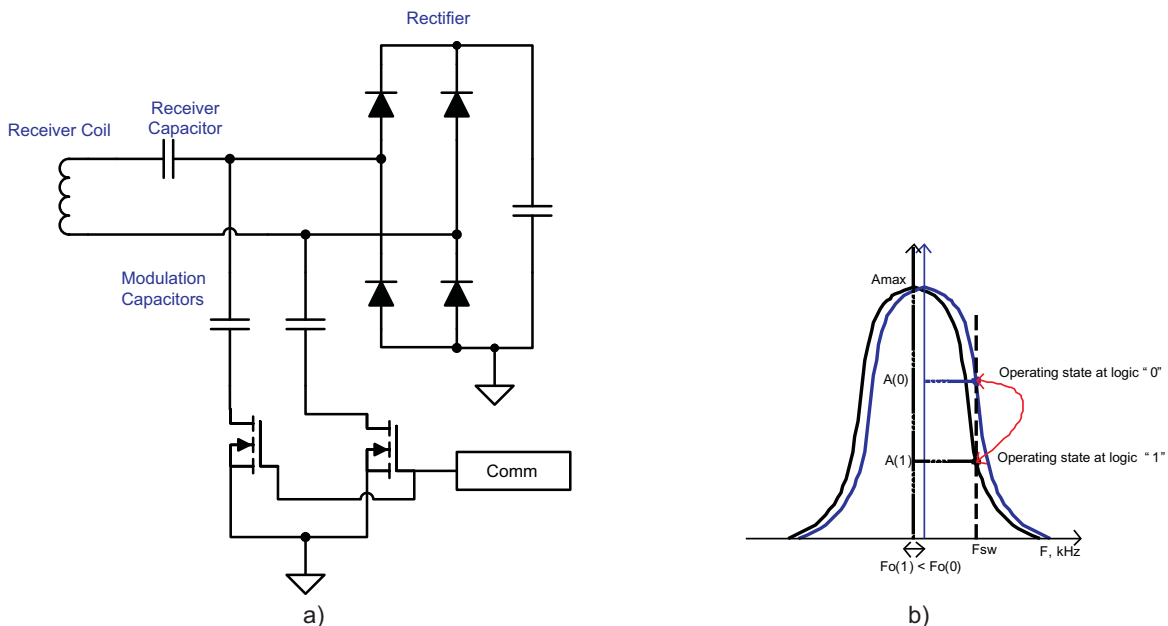

Figure 6. Receiver Capacitive Modulation Circuit

## 8 Application and Implementation

### NOTE

Information in the following applications sections is not part of the TI component specification, and TI does not warrant its accuracy or completeness. TI's customers are responsible for determining suitability of components for their purposes. Customers should validate and test their design implementation to confirm system functionality.

### 8.1 Application Information

The bq500511A device is a wireless power transmitter controller designed for 5W WPC compliant applications when paired with the bq50002A. The pair integrates all functions required to control wireless power transfer to a WPC v1.2 compliant receiver. Several tools are available for the design of the system. See the product folder on [www.ti.com](http://www.ti.com) for more details. The following sections highlight some of the system design considerations.

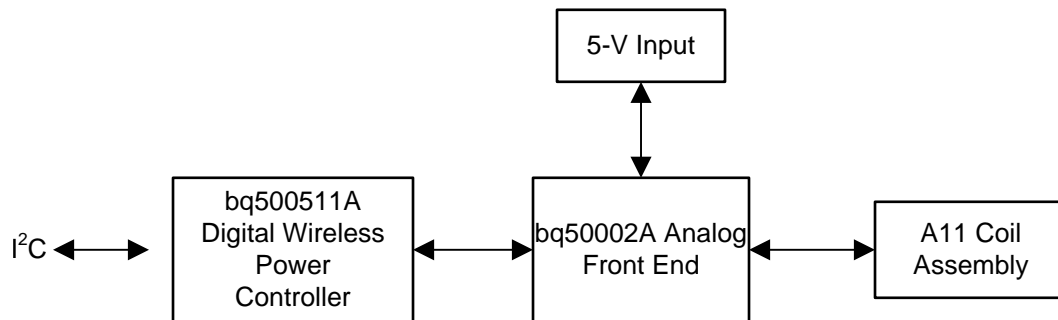

Copyright © 2016, Texas Instruments Incorporated

**Figure 7. bq500511A System Block Diagram**

The I<sup>2</sup>C port is accessed by the FOD tuning tool and can provide a level of system monitoring and evaluation.

The SDA and SCL lines of the I<sup>2</sup>C bus must be pulled up (as shown in the [Figure 8](#)) if the I<sup>2</sup>C port is utilized. They may be left floating if no I<sup>2</sup>C function is required. The logic reference generated by the bq50002A Analog Front End is 3 V, so care should be taken to ensure that if the Master I<sup>2</sup>C device also has pull-up resistors to a higher reference, that the the 3-V reference to the bq500511A is not affected. Specifically, only one set of pull-up resistors should be populated, either on the I<sup>2</sup>C Master bus or on the bq500511A system board, but not both.

**Additional details on I<sup>2</sup>C use and capabilities can be obtained by contacting TI.**

### 8.2 Typical Application

The bq500511A controller, when paired with bq50002A integrated Analog Front End device, requires a minimum of external components to implement a WPC 1.2 Wireless Power Transmitter system.

As shown in the application schematic, external components are used to implement the following functions:

- Resonant tank circuit
- Demodulator input signal conditioning
- Human interface (LED and Buzzer)
- Current sensing
- Voltage sensing
- Temperature sensing
- System Configuration: Foreign Objection Detection (FOD) threshold and calibration, LED mode

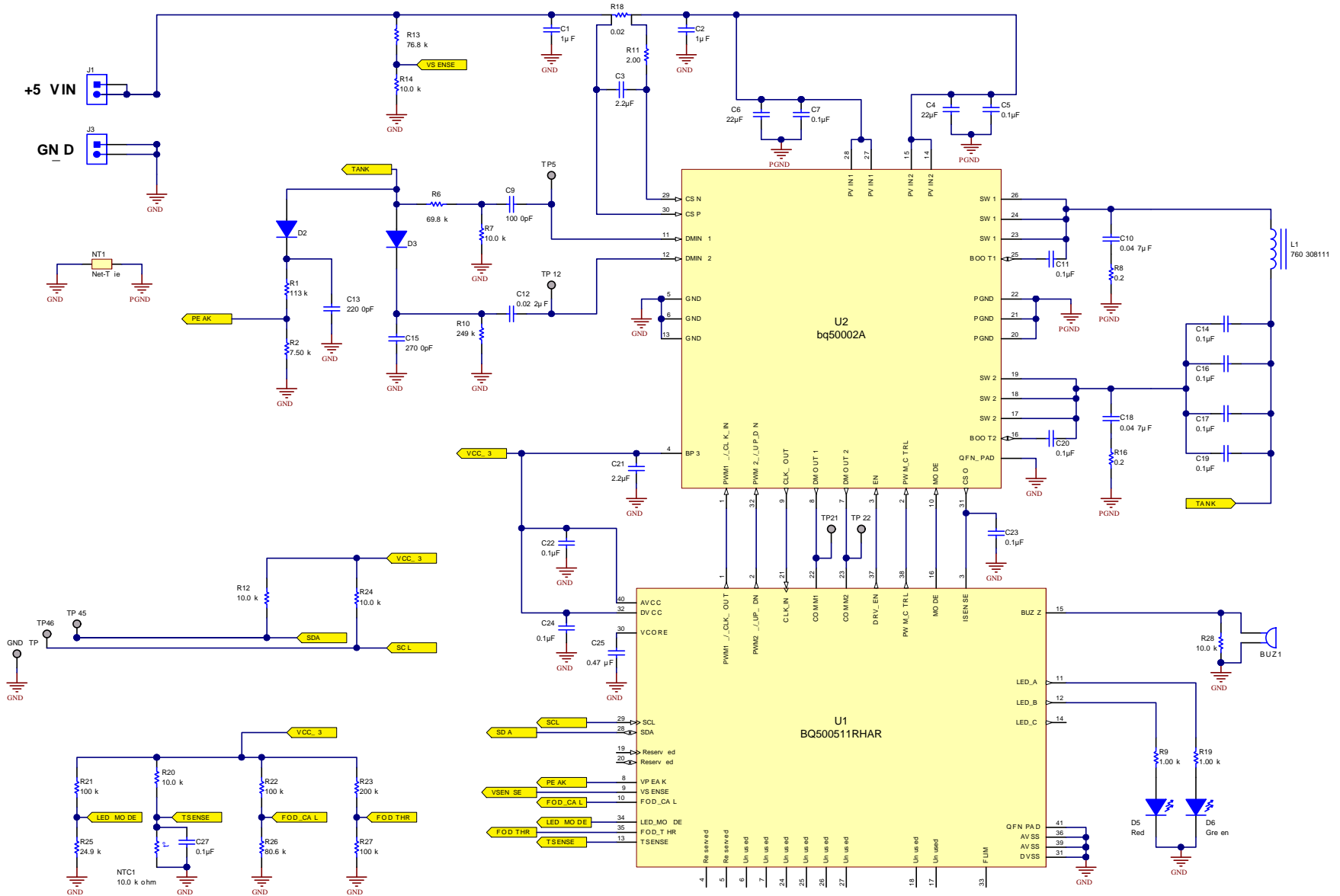

Copyright © 2016, Texas Instruments Incorporated

Figure 8. bq500511A Application Schematic

## 8.2.1 Design Requirements

For this design example, use the parameter listed in [Table 3](#) as the input parameter.

**Table 3. Design Parameters**

DESIGN PARAMETER	VALUE
WPC coil type	A11

## 8.2.2 Detailed Design Procedure

### 8.2.2.1 Capacitor Selection

Capacitor selection is critical to proper system operation. The total capacitance value of  $4 \times 100$  nF is required in the resonant tank. This is the WPC system compatibility requirement, not a guideline.

#### NOTE

A total capacitance value of  $4 \times 100$  nF (C0G dielectric type, 50-V rating) is required in the resonant tank to achieve the correct resonance frequency. The capacitors chosen must be rated for at least 50 V and must be of a high-quality C0G dielectric (sometimes also called NPO). These are typically available in a 5% tolerance, which is adequate. TI does **not** recommend the use of X7R types or below if WPC compliance is required because critical WPC Certification Testing, such as the minimum modulation or guaranteed power test, might fail. The designer can combine capacitors to achieve the desired capacitance value. Various combinations can work depending on market availability. All capacitors must be of C0G types (not mixed with any other dielectric types).

### 8.2.2.2 Current Monitoring Requirements

The bq500511A is WPC v1.2 ready. To enable the FOD feature, current monitoring is provided in the bq50002A Analog Front End. For proper scaling of the current monitor signal, the current sense resistor should be 20 mΩ. For FOD accuracy, the current sense resistor must be a quality component with 0.5% tolerance, at least 1/4-W rating, and a temperature stability of  $\pm 200$  PPM.

### 8.2.2.3 Input Voltage Monitoring

The VSENSE input is used to calculate power for the FOD function, and to detect the supply drooping when the bq500511A is receiving power from an insufficient adapter (for example from a weak USB port). The VSENSE input should reflect the input source voltage and should be scaled with a resistor divider comprising a 76.8 kΩ over 10 kΩ.

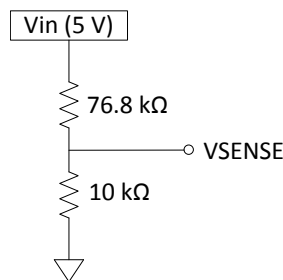

**Figure 9. VSENSE Signal Conditioning**

### 8.2.2.4 Tank Voltage Monitoring

The VPEAK input is used to estimate losses in the power components for the FOD function. The VPEAK input should reflect the envelope of the tank voltage (i.e. the node directly between the resonant capacitors and the primary coil) and should be buffered with a diode (100 V, 0.2 A) and scaled with a resistor divider comprising a 113 kΩ over 7.5 kΩ, with a 2200-pF filter capacitor.

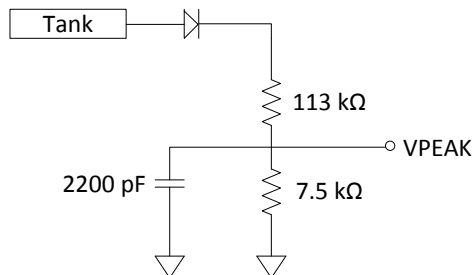

Figure 10. VPEAK Signal Conditioning

### 8.2.2.5 All Unused Pins

All unused pins can be left open unless otherwise indicated. Refer to the table in the [Pin Configuration and Functions](#) section. To improve PCB layout, ground unused pins, if it is an option.

### 8.2.2.6 Input Regulation

The bq500511A requires 3 VDC to operate. The regulator in the bq50002A provides this voltage rail eliminating the need for any external regulation.

### 8.2.2.7 System Input Power Requirements

The design works with 5-V input voltage to the bq50002A. The WPC defined A11 TX type requires 5-V system voltage in order to deliver 5 W of output power from the receiver.

### 8.2.2.8 LED Modes

The bq500511A can directly drive three LED outputs (pin 11 (LED-A), pin 12 (LED-B), and pin 14 (LED-C)). Select one of the desired LED indication schemes through the voltage on LED\_MODE (pin 34) by choosing appropriate values for the resistor divider.

## 8.2.3 Application Curves

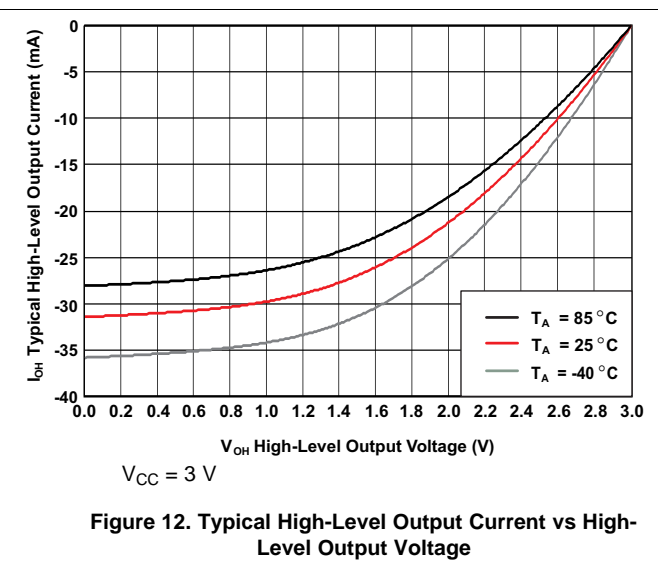
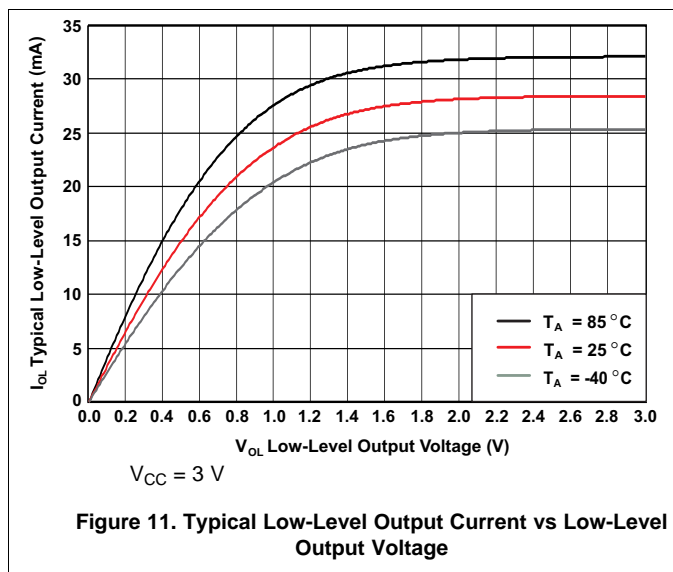

## 9 Power Supply Recommendations

The A11 TX type requires a 5-V system voltage.

## 10 Layout

### 10.1 Layout Guidelines

Careful PCB layout practice is critical to proper system operation. Many references are available on proper PCB layout techniques. A few good tips are as follows.

The TX layout requires a 4-layer PCB layout for best ground plane technique. A 2-layer PCB layout can be achieved though not as easily. Ideally, the approach to the layer stack-up is:

- Layer 1 component placement and as much ground plane as possible
- Layer 2 clean ground
- Layer 3 finish routing
- Layer 4 clean ground

Thus, the circuitry is virtually sandwiched between grounds. This minimizes EMI noise emissions and also provides a noise-free voltage reference plane for device operation.

Keep as much copper as possible. Make sure the bq500511A GND pins have a continuous flood connection to the ground plane. The power pad of the bq50002A should also be stitched to the ground plane, which also acts as a heat sink. A good GND reference is necessary for proper system operation, such as analog-digital conversion, clock stability, and best overall EMI performance. Separate the analog ground plane from the power ground plane and use only **one** tie point to connect grounds. Having several tie points defeats the purpose of separating the grounds. See the bq50002 EVM, [SLVUAJ7](#), for an example of a good layout technique.

#### 10.1.1 Layout Notes

Make sure the bypass capacitors intended for the bq500511A 3.3-V supply are actually bypassing these supply pins (pin 32, DVCC, and pin 40, AVCC) to solid ground plane (see [Figure 13](#)). This means they need to be placed as close to the device as possible and the traces must be as wide as possible.

Make sure the bq500511A has a continuous flood connection to the ground plane (see [Figure 14](#)).

The full-bridge power stage that drives the TX coil is composed of two half-bridge power stages (integrated in bq50002A) and resonant capacitors. Input bypass capacitors should be placed as close as possible to the bq50002A PVIN1 pins (pin 27, 28) and PVIN2 pins (pin 14, 15). The input and ground pours and traces should be made as wide as possible for better current flow. The trace to the coil and resonant capacitors should also be made as wide as possible (see [Figure 15](#)).

To ensure proper operation, grounds conducting a large amount of current and switching noise must be isolated from low current, quiet grounds. Separate the ground pours for the power stages and the bq500511A IC. Connect all grounds to a single point at the main ground terminal (see [Figure 15](#)).

Proper current sensing layout technique is very important, as it directly affects the FOD and PMOD performance. When sampling the very-low voltages generated across a current sense resistor, be sure to use the so called 4-wire or Kelvin-connection technique. This is important to avoid introducing false voltage drops from adjacent pads and copper power routes. It is a common power-supply layout technique. Some high-accuracy sense resistors have dedicated sense pins (see [Figure 17](#)).

The trace from bq50002A CSP pin to sense resistor must be minimized to avoid unwanted offset in the application. This trace should be limited to less than 20-mΩ resistance.

## 10.2 Layout Examples

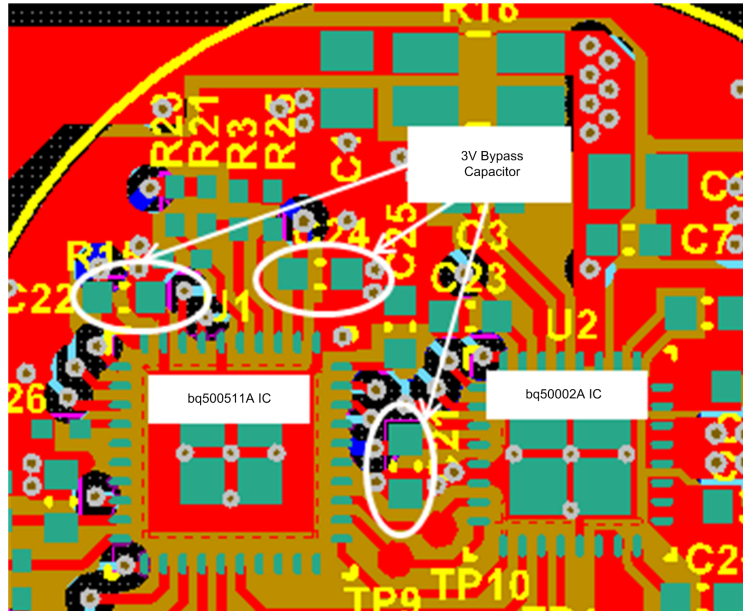

Figure 13. Bypass Capacitors Layout

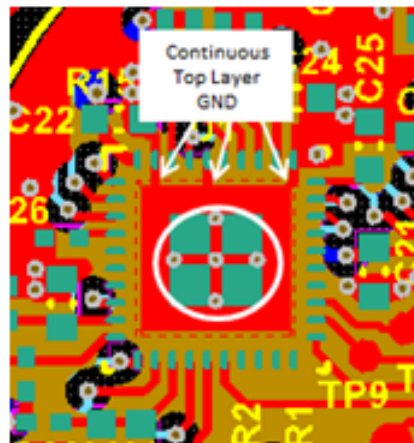
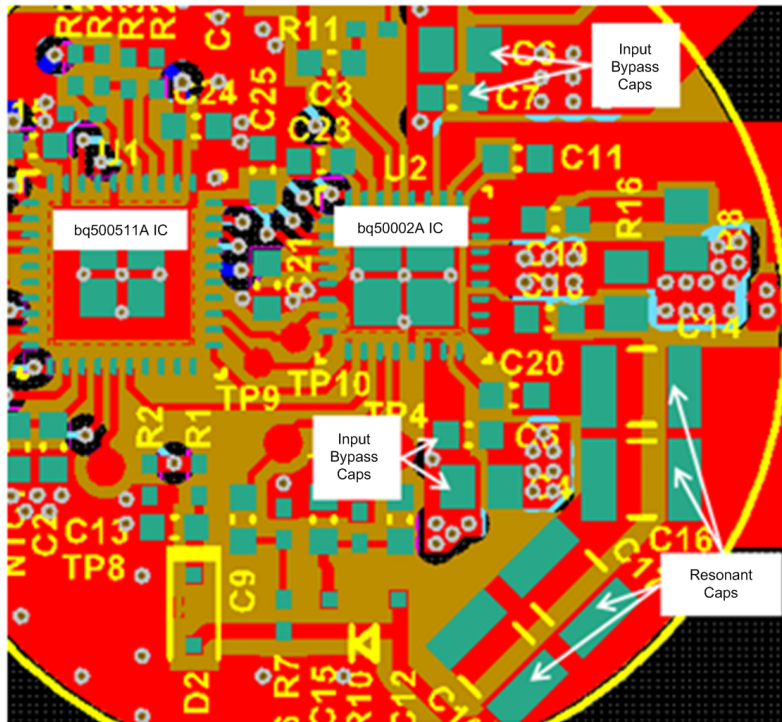
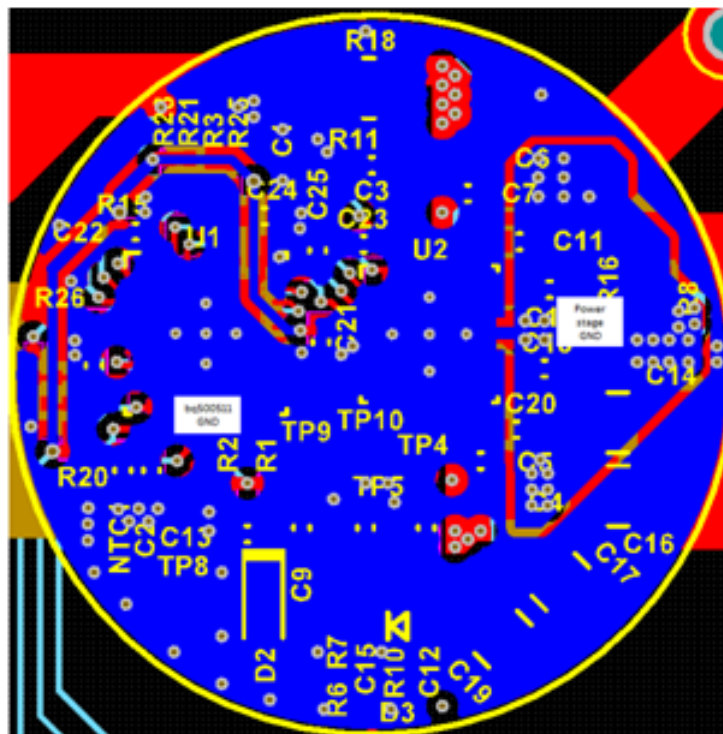

Figure 14. Continuous GND Layout

**Layout Examples (continued)**



**Figure 15. Ground Layout**



**Figure 16. Ground Layout**

### Layout Examples (continued)

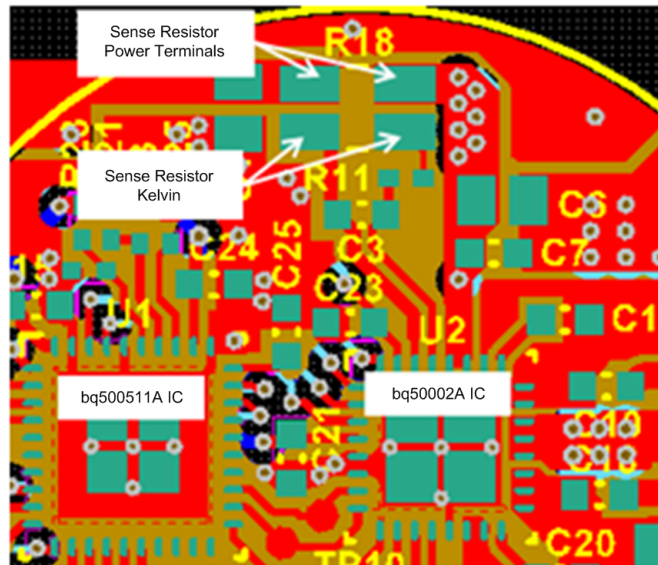

Figure 17. Current Sensing Layout

## 11 Device and Documentation Support

### 11.1 Device Support

#### 11.1.1 Third-Party Products Disclaimer

TI'S PUBLICATION OF INFORMATION REGARDING THIRD-PARTY PRODUCTS OR SERVICES DOES NOT CONSTITUTE AN ENDORSEMENT REGARDING THE SUITABILITY OF SUCH PRODUCTS OR SERVICES OR A WARRANTY, REPRESENTATION OR ENDORSEMENT OF SUCH PRODUCTS OR SERVICES, EITHER ALONE OR IN COMBINATION WITH ANY TI PRODUCT OR SERVICE.

### 11.2 Documentation Support

#### 11.2.1 Related Documentation

For related documentation see the following:

1. Technology, *Wireless Power Consortium*, [www.wirelesspowerconsortium.com](http://www.wirelesspowerconsortium.com)
2. Analog applications journal, *An Introduction to the Wireless Power Consortium Standard and TI's Compliant Solutions*, Johns, Bill, [SLYT401](#)
3. *Integrated Wireless Power Supply Receiver, Qi (WPC) Compliant*, bq51011, bq51013, [SLVSAT9](#)
4. *Building a Wireless Power Transmitter*, [SLUA635](#)
5. *bqTESLA Transmitter Coil Vendors*, [SLUA649](#)
6. *bq50002 Wireless Power TX EVM*, [SLVUAJ7](#)

#### 11.3 Receiving Notification of Documentation Updates

To receive notification of documentation updates, navigate to the device product folder on ti.com. In the upper right corner, click on Alert me to register and receive a weekly digest of any product information that has changed. For change details, review the revision history included in any revised document.

#### 11.4 Community Resources

The following links connect to TI community resources. Linked contents are provided "AS IS" by the respective contributors. They do not constitute TI specifications and do not necessarily reflect TI's views; see TI's [Terms of Use](#).

**TI E2E™ Online Community** *TI's Engineer-to-Engineer (E2E) Community*. Created to foster collaboration among engineers. At [e2e.ti.com](http://e2e.ti.com), you can ask questions, share knowledge, explore ideas and help solve problems with fellow engineers.

**Design Support** *TI's Design Support* Quickly find helpful E2E forums along with design support tools and contact information for technical support.

#### 11.5 Trademarks

Dynamic Power Limiting (DPL), E2E are trademarks of Texas Instruments. All other trademarks are the property of their respective owners.

#### 11.6 Electrostatic Discharge Caution



These devices have limited built-in ESD protection. The leads should be shorted together or the device placed in conductive foam during storage or handling to prevent electrostatic damage to the MOS gates.

#### 11.7 Glossary

[SLYZ022](#) — *TI Glossary*.

This glossary lists and explains terms, acronyms, and definitions.

## 12 Mechanical, Packaging, and Orderable Information

The following pages include mechanical, packaging, and orderable information. This information is the most current data available for the designated devices. This data is subject to change without notice and revision of this document. For browser-based versions of this data sheet, refer to the left-hand navigation.

**PACKAGING INFORMATION**

Orderable Device	Status (1)	Package Type	Package Drawing	Pins	Package Qty	Eco Plan (2)	Lead/Ball Finish (6)	MSL Peak Temp (3)	Op Temp (°C)	Device Marking (4/5)	Samples
BQ500511ARHAR	NRND	VQFN	RHA	40	2500	Green (RoHS & no Sb/Br)	CU NIPDAU	Level-3-260C-168 HR	-40 to 85	Q500511A	
BQ500511ARHAT	NRND	VQFN	RHA	40	250	Green (RoHS & no Sb/Br)	CU NIPDAU	Level-3-260C-168 HR	-40 to 85	Q500511A	

(1) The marketing status values are defined as follows:

**ACTIVE:** Product device recommended for new designs.

**LIFEBUY:** TI has announced that the device will be discontinued, and a lifetime-buy period is in effect.

**NRND:** Not recommended for new designs. Device is in production to support existing customers, but TI does not recommend using this part in a new design.

**PREVIEW:** Device has been announced but is not in production. Samples may or may not be available.

**OBSOLETE:** TI has discontinued the production of the device.

(2) **RoHS:** TI defines "RoHS" to mean semiconductor products that are compliant with the current EU RoHS requirements for all 10 RoHS substances, including the requirement that RoHS substance do not exceed 0.1% by weight in homogeneous materials. Where designed to be soldered at high temperatures, "RoHS" products are suitable for use in specified lead-free processes. TI may reference these types of products as "Pb-Free".

**RoHS Exempt:** TI defines "RoHS Exempt" to mean products that contain lead but are compliant with EU RoHS pursuant to a specific EU RoHS exemption.

**Green:** TI defines "Green" to mean the content of Chlorine (Cl) and Bromine (Br) based flame retardants meet JS709B low halogen requirements of <=1000ppm threshold. Antimony trioxide based flame retardants must also meet the <=1000ppm threshold requirement.

(3) MSL, Peak Temp. - The Moisture Sensitivity Level rating according to the JEDEC industry standard classifications, and peak solder temperature.

(4) There may be additional marking, which relates to the logo, the lot trace code information, or the environmental category on the device.

(5) Multiple Device Markings will be inside parentheses. Only one Device Marking contained in parentheses and separated by a "~" will appear on a device. If a line is indented then it is a continuation of the previous line and the two combined represent the entire Device Marking for that device.

(6) Lead/Ball Finish - Orderable Devices may have multiple material finish options. Finish options are separated by a vertical ruled line. Lead/Ball Finish values may wrap to two lines if the finish value exceeds the maximum column width.

**Important Information and Disclaimer:**The information provided on this page represents TI's knowledge and belief as of the date that it is provided. TI bases its knowledge and belief on information provided by third parties, and makes no representation or warranty as to the accuracy of such information. Efforts are underway to better integrate information from third parties. TI has taken and continues to take reasonable steps to provide representative and accurate information but may not have conducted destructive testing or chemical analysis on incoming materials and chemicals. TI and TI suppliers consider certain information to be proprietary, and thus CAS numbers and other limited information may not be available for release.

In no event shall TI's liability arising out of such information exceed the total purchase price of the TI part(s) at issue in this document sold by TI to Customer on an annual basis.



**TAPE AND REEL INFORMATION**

**QUADRANT ASSIGNMENTS FOR PIN 1 ORIENTATION IN TAPE**

\*All dimensions are nominal

Device	Package Type	Package Drawing	Pins	SPQ	Reel Diameter (mm)	Reel Width W1 (mm)	A0 (mm)	B0 (mm)	K0 (mm)	P1 (mm)	W (mm)	Pin1 Quadrant
BQ500511ARHAR	VQFN	RHA	40	2500	330.0	16.4	6.3	6.3	1.1	12.0	16.0	Q2
BQ500511ARHAT	VQFN	RHA	40	250	180.0	16.4	6.3	6.3	1.1	12.0	16.0	Q2

**TAPE AND REEL BOX DIMENSIONS**

\*All dimensions are nominal

Device	Package Type	Package Drawing	Pins	SPQ	Length (mm)	Width (mm)	Height (mm)
BQ500511ARHAR	VQFN	RHA	40	2500	367.0	367.0	38.0
BQ500511ARHAT	VQFN	RHA	40	250	210.0	185.0	35.0

RHA (S-PVQFN-N40)

PLASTIC QUAD FLATPACK NO-LEAD

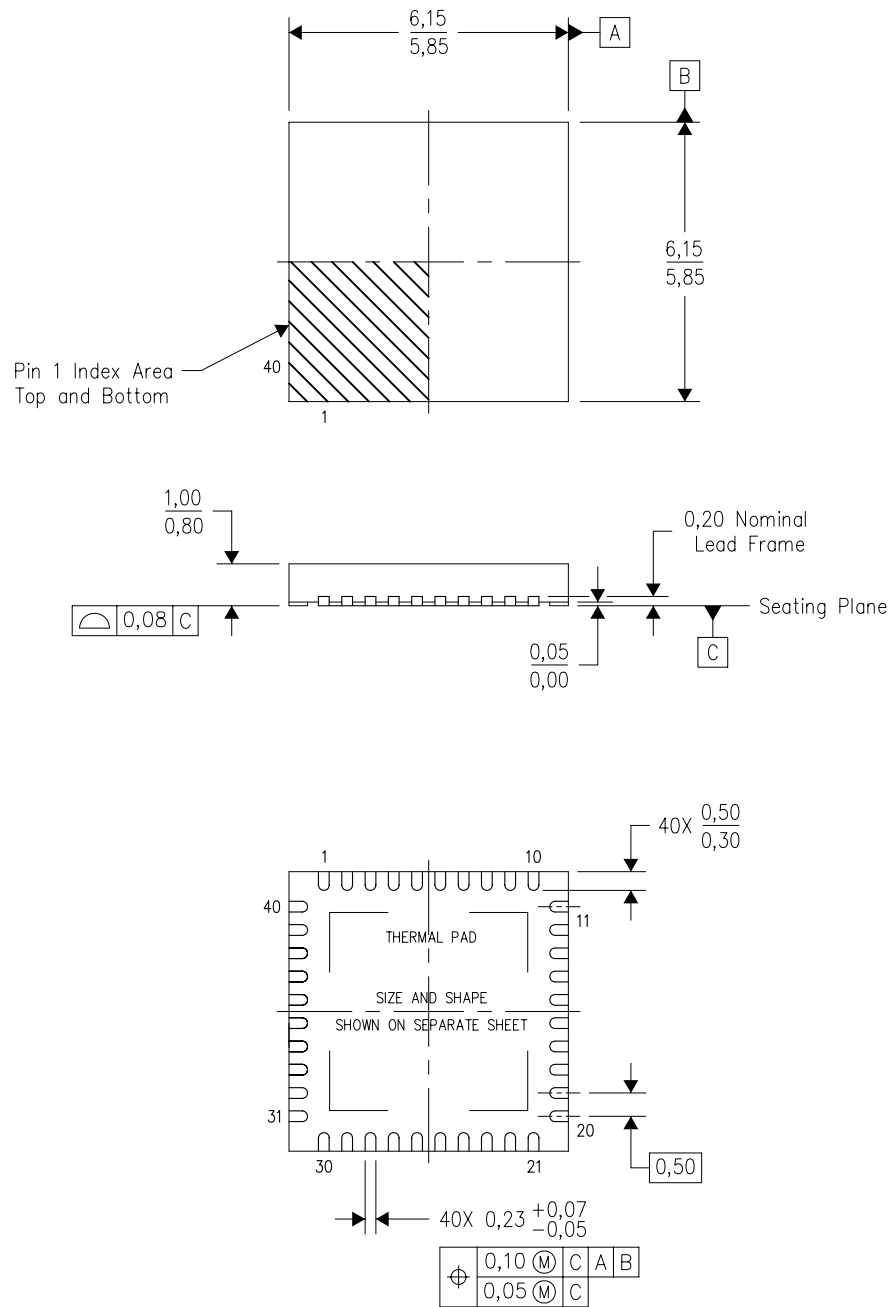

Bottom View

4204276/E 06/11

- NOTES:
- All linear dimensions are in millimeters. Dimensioning and tolerancing per ASME Y14.5M-1994.
  - This drawing is subject to change without notice.
  - QFN (Quad Flatpack No-Lead) Package configuration.
  - The package thermal pad must be soldered to the board for thermal and mechanical performance.
  - See the additional figure in the Product Data Sheet for details regarding the exposed thermal pad features and dimensions.
  - Package complies to JEDEC MO-220 variation VJJD-2.

# THERMAL PAD MECHANICAL DATA

RHA (S-PVQFN-N40)

PLASTIC QUAD FLATPACK NO-LEAD

## THERMAL INFORMATION

This package incorporates an exposed thermal pad that is designed to be attached directly to an external heatsink. The thermal pad must be soldered directly to the printed circuit board (PCB). After soldering, the PCB can be used as a heatsink. In addition, through the use of thermal vias, the thermal pad can be attached directly to the appropriate copper plane shown in the electrical schematic for the device, or alternatively, can be attached to a special heatsink structure designed into the PCB. This design optimizes the heat transfer from the integrated circuit (IC).

For information on the Quad Flatpack No-Lead (QFN) package and its advantages, refer to Application Report, QFN/SON PCB Attachment, Texas Instruments Literature No. SLUA271. This document is available at [www.ti.com](http://www.ti.com).

The exposed thermal pad dimensions for this package are shown in the following illustration.

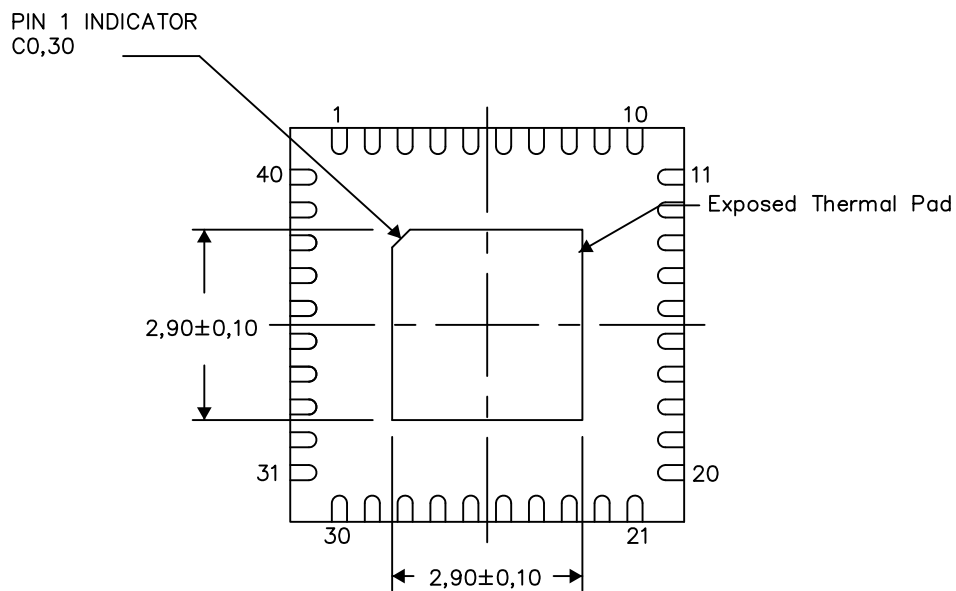

Bottom View

Exposed Thermal Pad Dimensions

4206355-3/X 08/14

NOTES: A. All linear dimensions are in millimeters

RHA (S-PVQFN-N40)

PLASTIC QUAD FLATPACK NO-LEAD

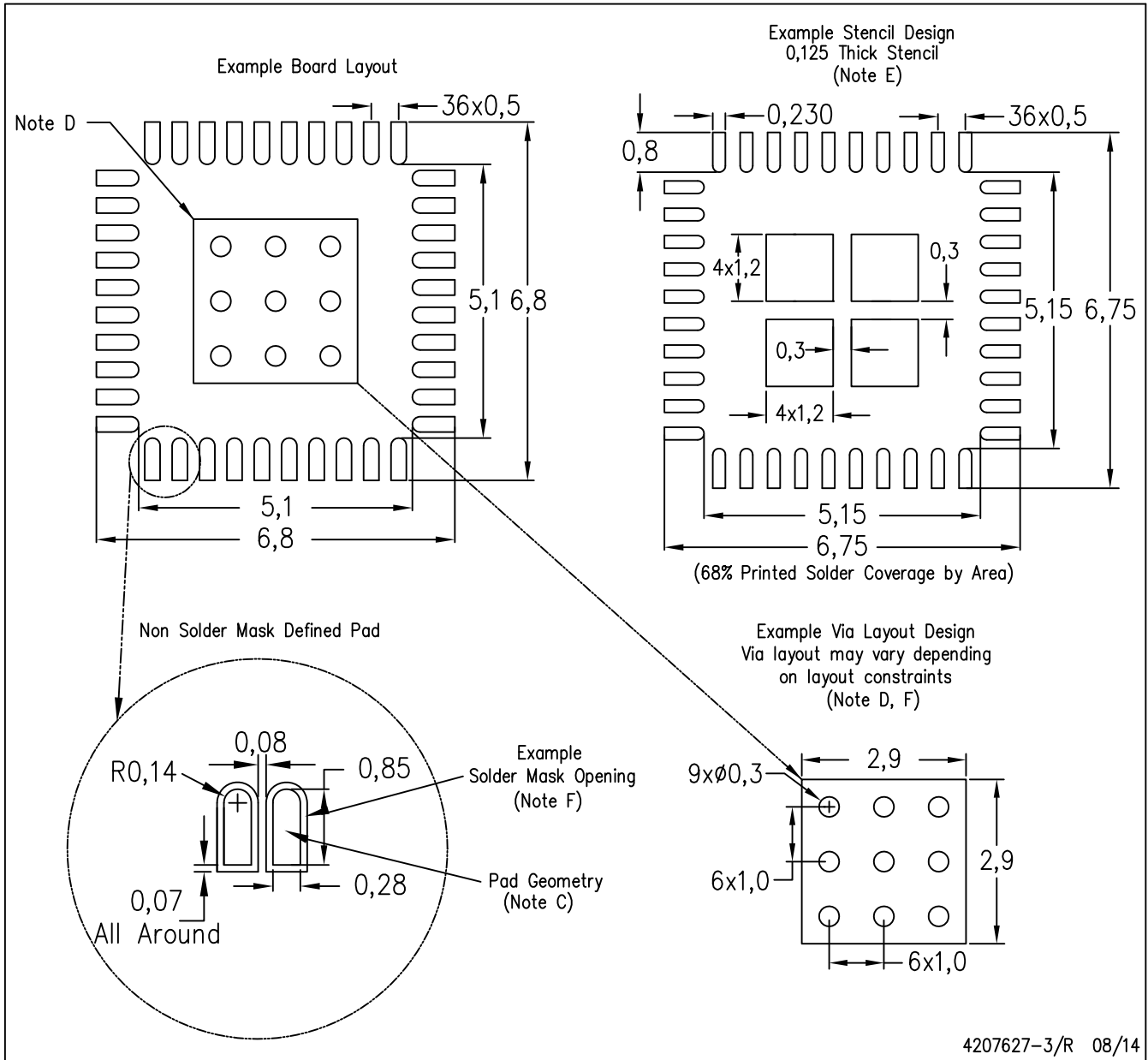

- NOTES:
- All linear dimensions are in millimeters.
  - This drawing is subject to change without notice.
  - Publication IPC-7351 is recommended for alternate designs.
  - This package is designed to be soldered to a thermal pad on the board. Refer to Application Note, Quad Flat-Pack Packages, Texas Instruments Literature No. SLUA271, and also the Product Data Sheets for specific thermal information, via requirements, and recommended board layout. These documents are available at [www.ti.com](http://www.ti.com) <<http://www.ti.com>>.
  - Laser cutting apertures with trapezoidal walls and also rounding corners will offer better paste release. Customers should contact their board assembly site for stencil design recommendations. Refer to IPC 7525 for stencil design considerations.
  - Customers should contact their board fabrication site for recommended solder mask tolerances and via tenting recommendations for vias placed in the thermal pad.

## IMPORTANT NOTICE AND DISCLAIMER

TI PROVIDES TECHNICAL AND RELIABILITY DATA (INCLUDING DATASHEETS), DESIGN RESOURCES (INCLUDING REFERENCE DESIGNS), APPLICATION OR OTHER DESIGN ADVICE, WEB TOOLS, SAFETY INFORMATION, AND OTHER RESOURCES "AS IS" AND WITH ALL FAULTS, AND DISCLAIMS ALL WARRANTIES, EXPRESS AND IMPLIED, INCLUDING WITHOUT LIMITATION ANY IMPLIED WARRANTIES OF MERCHANTABILITY, FITNESS FOR A PARTICULAR PURPOSE OR NON-INFRINGEMENT OF THIRD PARTY INTELLECTUAL PROPERTY RIGHTS.

These resources are intended for skilled developers designing with TI products. You are solely responsible for (1) selecting the appropriate TI products for your application, (2) designing, validating and testing your application, and (3) ensuring your application meets applicable standards, and any other safety, security, or other requirements. These resources are subject to change without notice. TI grants you permission to use these resources only for development of an application that uses the TI products described in the resource. Other reproduction and display of these resources is prohibited. No license is granted to any other TI intellectual property right or to any third party intellectual property right. TI disclaims responsibility for, and you will fully indemnify TI and its representatives against, any claims, damages, costs, losses, and liabilities arising out of your use of these resources.

TI's products are provided subject to TI's Terms of Sale ([www.ti.com/legal/termsofsale.html](http://www.ti.com/legal/termsofsale.html)) or other applicable terms available either on [ti.com](http://ti.com) or provided in conjunction with such TI products. TI's provision of these resources does not expand or otherwise alter TI's applicable warranties or warranty disclaimers for TI products.

Mailing Address: Texas Instruments, Post Office Box 655303, Dallas, Texas 75265  
Copyright © 2019, Texas Instruments Incorporated

## Looking for pricing, stock, or lifecycle information?

Click below to explore more details on WIN SOURCE:

 [View BQ500511ARHAT on WIN SOURCE](#)

 [Texas Instruments](#) Information

## Optimize Your Supply Chain with WIN SOURCE Solutions

-  Global Sourcing Solution
-  Obsolete Management
-  Cost Control Management
-  Shortage Management
-  Alternative Solution
-  Excess Inventory Management