

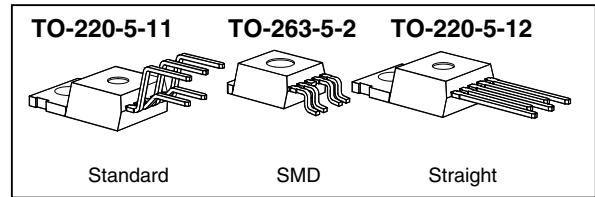

Product Summary

On-state Resistance	RON	20mΩ
Operating Voltage	Vbb(on)	4.75 ... 41V
Nominal load current	IL(ISO)	21A
Current limitation	IL(lim)	65A

Package



General Description

- N channel vertical power FET with charge pump, ground referenced CMOS compatible input, monolithically integrated in Smart SIPMOS® technology.
- Providing embedded protective functions.
- Green Product (RoHS compliant)
- AEC Qualified

Application

- μC compatible power switch for 5V, 12 V and 24 V DC applications
- All types of resistive, inductive and capacitive loads
- Most suitable for loads with high inrush currents, so as lamps
- Replaces electromechanical relays, fuses and discrete circuits

Basic Functions

- Very low standby current
- Optimized static electromagnetic compatibility (EMC)
- μC and CMOS compatible
- Fast demagnetization of inductive loads
- Stable behaviour at undervoltage

Protection Functions

- Short circuit protection
- Current limitation
- Overload protection
- Thermal shutdown
- Overvoltage protection (including load dump) with external GND-resistor
- Reverse battery protection with external GND-resistor
- Loss of ground and loss of Vbb protection
- Electrostatic discharge (ESD) protection

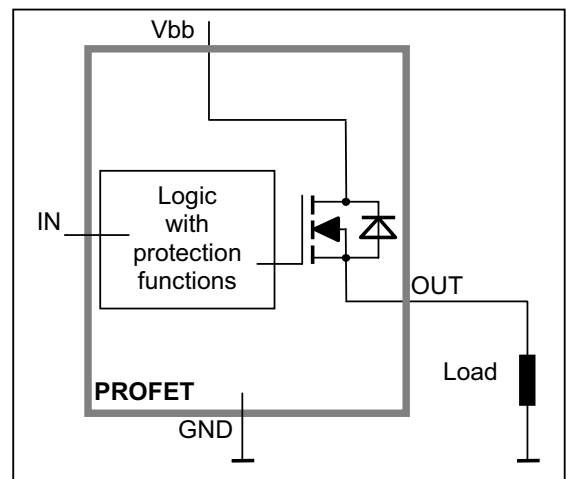

Functional diagram

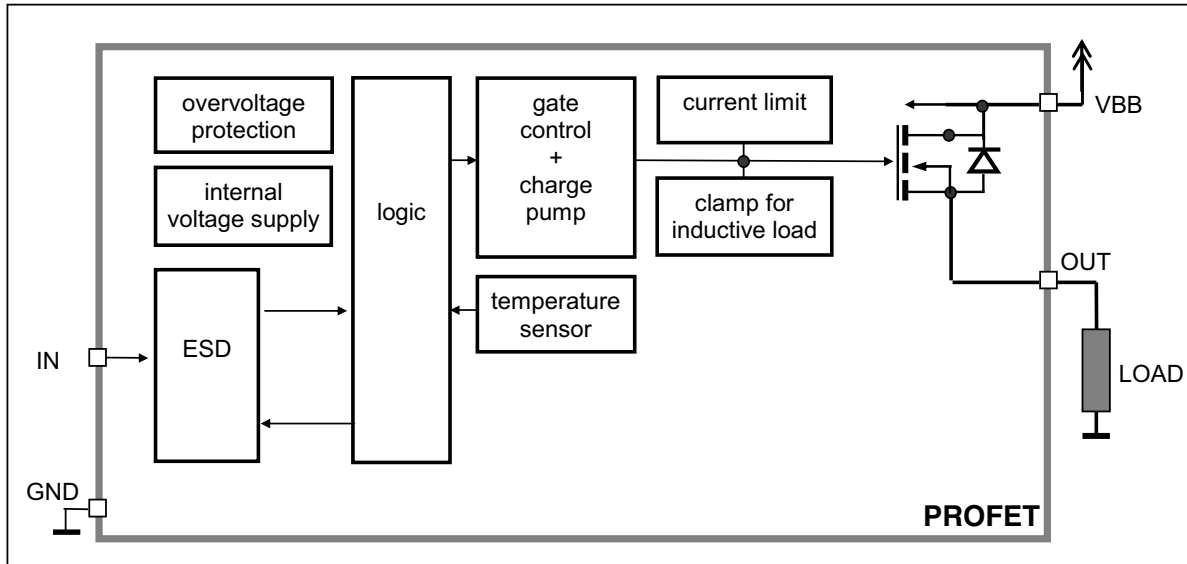

Pin Definitions and Functions

Pin	Symbol	Function
1	GND	Logic ground
2	IN	Input , activates the power switch in case of logical high signal
3	V_{bb}	Positive power supply voltage The tab is shorted to pin 3
4	N.C.	Not connected
5	OUT	Output to the load
Tab	V_{bb}	Positive power supply voltage The tab is shorted to pin 3

Pin configuration

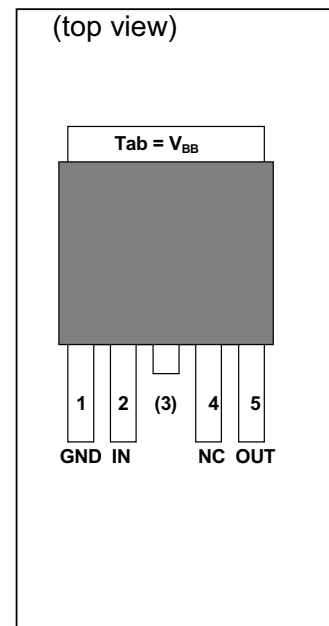

Maximum Ratings at $T_j = 25\text{ °C}$ unless otherwise specified

Parameter	Symbol	Values	Unit	
Supply voltage (overvoltage protection see page 4)	V_{bb}	43	V	
Supply voltage for full short circuit protection $T_{j\text{ Start}}=-40 \dots +150\text{ °C}$	V_{bb}	34	V	
Load dump protection ¹⁾ $V_{\text{LoadDump}} = V_A + V_S$, $V_A = 13.5\text{ V}$ $R_i^2 = 2\ \Omega$, $R_L = 0,5\ \Omega$, $t_d = 200\text{ ms}$, IN= low or high	$V_{\text{Load dump}}^3)$	60	V	
Load current (Short-circuit current, see page 5)	I_L	self-limited	A	
Operating temperature range	T_j	-40 ... +150	°C	
Storage temperature range	T_{stg}	-55 ... +150		
Power dissipation (DC) ; $TC \leq 25\text{ °C}$	P_{tot}	125	W	
Maximal switchable inductance, single pulse $V_{bb} = 12\text{ V}$, $T_{j,\text{start}} = 150\text{ °C}$, $T_C = 150\text{ °C const.}$ (see diagram, p.8) $I_{L(\text{ISO})} = 21\text{ A}$, $R_L = 0\ \Omega$: $E^4_{AS} = 0.7\text{ J}$:	Z_L	2.1	mH	
Electrostatic discharge capability (ESD) IN: (Human Body Model) Out to all other pins shorted: acc. MIL-STD883D, method 3015.7 and ESD assn. std. S5.1-1993; $R = 1.5\text{ k}\Omega$; $C = 100\text{ pF}$	V_{ESD}	1.0 8.0	kV	
Input voltage (DC)	V_{IN}	-10 ... +16	V	
Current through input pin (DC) see internal circuit diagrams page 7	I_{IN}	± 2.0	mA	
Thermal resistance	chip - case: junction - ambient (free air): SMD version, device on pcb ⁵⁾ :	R_{thJC} R_{thJA}	≤ 1 ≤ 75 ≤ 33	K/W

- 1) Supply voltages higher than $V_{bb(AZ)}$ require an external current limit for the GND pin, e.g. with a $150\ \Omega$ resistor in the GND connection. A resistor for the protection of the input is integrated.
- 2) R_i = internal resistance of the load dump test pulse generator
- 3) $V_{\text{Load dump}}$ is setup without the DUT connected to the generator per ISO 7637-1 and DIN 40839
- 4) E_{AS} is the maximum inductive switch off energy
- 5) Device on $50\text{ mm} \times 50\text{ mm} \times 1.5\text{ mm}$ epoxy PCB FR4 with 6 cm^2 (one layer, $70\ \mu\text{m}$ thick) copper area for V_{bb} connection. PCB is vertical without blown air.

Electrical Characteristics

Parameter and Conditions at $T_j = -40 \dots +150^\circ\text{C}$, $V_{bb} = 12\text{ V}$ unless otherwise specified	Symbol	Values			Unit
		min	typ	max	

Load Switching Capabilities and Characteristics

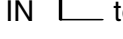
On-state resistance (V_{bb} (pin3) to OUT (pin5)); $I_L = 2\text{ A}$, $V_{bb} \geq 7\text{ V}$; see diagram page 9	$T_j = 25^\circ\text{C}$: $T_j = 150^\circ\text{C}$:	R_{ON}	--	15 28	20 37	m Ω
Nominal load current (pin 3 to 5) 'ISO 10483-1, 6.7: $V_{ON} = 0.5\text{ V}$, $T_c = 85^\circ\text{C}$		$I_{L(ISO)}$	17	21	--	A
Output current (pin 5) while GND disconnected or GND pulled up ⁶⁾ , $V_{bb} = 30\text{ V}$, $V_{IN} = 0$, see diagram page 7		$I_{L(GNDhigh)}$	--	--	2	mA
Turn-on time Turn-off time $R_L = 12\ \Omega$,	IN  to 90% V_{OUT} : IN  to 10% V_{OUT} :	t_{on} t_{off}	40 40	90 110	200 250	μs
Slew rate on 10 to 30% V_{OUT} , $R_L = 12\ \Omega$,		dV/dt_{on}	0.1	--	1	V/ μs
Slew rate off 70 to 40% V_{OUT} , $R_L = 12\ \Omega$,		$-dV/dt_{off}$	0.1	--	1	V/ μs

Operating Parameters

Operating voltage	$T_j = -40^\circ\text{C}$ $T_j = +25^\circ\text{C}$ $T_j = +105^\circ\text{C}$ ⁶⁾ $T_j = +150^\circ\text{C}$	$V_{bb(on)}$	4.75 4.75 4.75 5.0	-- -- -- --	41 43 43 43	V
Overvoltage protection ⁷⁾ $I_{bb} = 40\text{ mA}$	$T_j = -40^\circ\text{C}$: $T_j = +25 \dots +150^\circ\text{C}$:	$V_{bb(AZ)}$	41 43	-- 47	-- 52	V
Standby current (pin 3) ⁸⁾ $V_{IN} = 0$ see diagram page 9	$T_j = -40 \dots +25^\circ\text{C}$: $T_j = +105^\circ\text{C}$ ⁶⁾ : $T_j = +150^\circ\text{C}$:	$I_{bb(off)}$	-- -- --	-- -- --	5 10 25	μA
Off-State output current (included in $I_{bb(off)}$) $V_{IN} = 0$		$I_{L(off)}$	--	1.5	10	μA
Operating current (Pin 1) ⁹⁾ , $V_{IN} = 5\text{ V}$,		I_{GND}	--	2	4	mA

⁶⁾ not subject to production test, specified by design

⁷⁾ see also $V_{ON(CL)}$ in table of protection functions and circuit diagram page 7

⁸⁾ Measured with load, typ. 40 μA without load.

⁹⁾ Add I_{IN} , if $V_{IN} > 5.5\text{ V}$



Parameter and Conditions at $T_j = -40\dots+150^\circ\text{C}$, $V_{bb} = 12\text{ V}$ unless otherwise specified	Symbol	Values			Unit
		min	typ	max	
Protection Functions¹⁰⁾					
Current limit (pin 3 to 5) (see timing diagrams, page 9)	$I_{L(\text{lim})}$				
	$T_j = -40^\circ\text{C}$:	--	--	85	A
	$T_j = 25^\circ\text{C}$:	--	65	--	
	$T_j = +150^\circ\text{C}$:	40	--	--	
Repetitive short circuit current limit $T_j = T_{jt}$ (see timing diagrams, page 10)	$I_{L(\text{SCR})}$	--	55	--	A
Thermal shutdown time ¹¹⁾¹²⁾ (see timing diagram on page 10)	$T_{j,\text{start}} = 25^\circ\text{C}$: $T_{\text{off}(\text{SC})}$	--	14	--	ms
Output clamp (inductive load switch off) at $V_{\text{OUT}} = V_{bb} - V_{\text{ON}(\text{CL})}$, $I_L = 40\text{ mA}$	$V_{\text{ON}(\text{CL})}$	41	--	--	V
	$T_j = -40^\circ\text{C}$:	43	47	52	
	$T_j = 25\dots150^\circ\text{C}$:				
Thermal overload trip temperature	T_{jt}	150	--	--	$^\circ\text{C}$
Thermal hysteresis	ΔT_{jt}	--	10	--	K
Reverse battery (pin 3 to 1) ¹³⁾	$-V_{bb}$	--	--	32	V
Reverse battery voltage drop ($V_{\text{OUT}} > V_{bb}$) $I_L = -2\text{ A}$	$-V_{\text{ON}(\text{rev})}$	--	540	--	mV

¹⁰⁾ Integrated protection functions are designed to prevent IC destruction under fault conditions described in the data sheet. Fault conditions are considered as "outside" normal operating range. Protection functions are not designed for continuous repetitive operation.

¹¹⁾ not subject to production test, specified by design

¹²⁾ Device on 50mm*50mm*1.5mm epoxy PCB FR4 with 6cm² (one layer, 70μm thick) copper area for V_{bb} connection. PCB is vertical without blown air.

¹³⁾ Requires 150 Ω resistor in GND connection. The reverse load current through the intrinsic drain-source diode has to be limited by the connected load. Note that the power dissipation is higher compared to normal operating conditions due to the voltage drop across the intrinsic drain-source diode. The temperature protection is not active during reverse current operation! Input and Status currents have to be limited (see max. ratings page 1 and circuit page 7).

Parameter and Conditions at $T_j = -40...+150^\circ\text{C}$, $V_{bb} = 12\text{ V}$ unless otherwise specified	Symbol	Values			Unit
		min	typ	max	
Input¹⁴⁾					
Input resistance see circuit page 7	R_I	2.5	3.8	6.5	$\text{k}\Omega$
Input turn-on threshold voltage 	$V_{IN(T+)}$	1.2	--	2.2	V
Input turn-off threshold voltage 	$V_{IN(T-)}$	0.8	--	--	V
Input threshold hysteresis	$\Delta V_{IN(T)}$	--	0.3	--	V
Off state input current (pin 2) $V_{IN} = 0.4\text{ V}$:	$I_{IN(off)}$	1	--	15	μA
On state input current (pin 2) $V_{IN} = 5\text{ V}$:	$I_{IN(on)}$	4.5	12	24	μA

¹⁴⁾ If a ground resistor R_{GND} is used, add the voltage drop across this resistor.

Terms

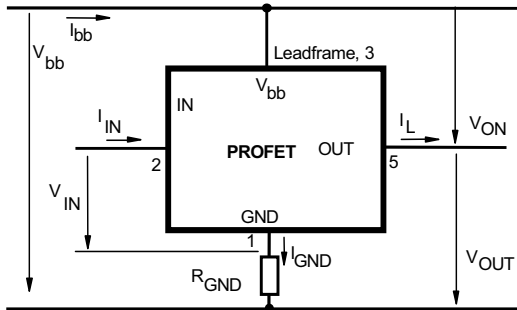

Input circuit (ESD protection)

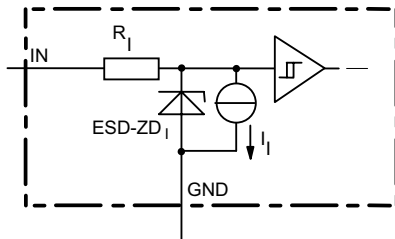

The use of ESD zener diodes as voltage clamp at DC conditions is not recommended.

Inductive and overvoltage output clamp

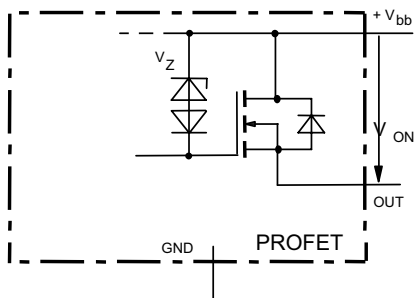

V_{ON} clamped to 47 V typ.

Overvolt. and reverse batt. protection

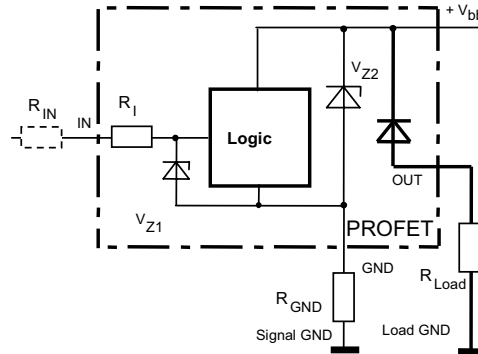

$V_{Z1} = 6.1$ V typ., $V_{Z2} = 47$ V typ., $R_{GND} = 150$ Ω , $R_I = 3.5$ k Ω typ.

In case of reverse battery the load current has to be limited by the load. Temperature protection is not active

GND disconnect

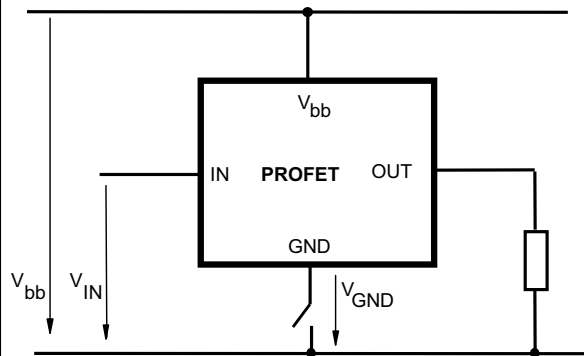

Any kind of load. In case of Input=high is $V_{OUT} \approx V_{IN} - V_{IN(T+)}$.

GND disconnect with GND pull up

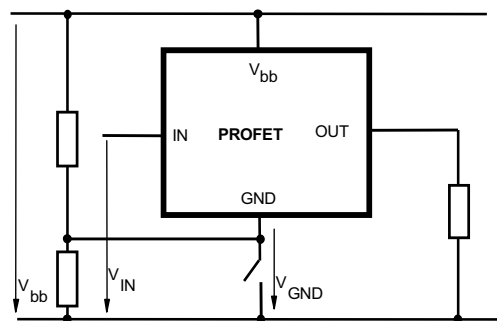

Any kind of load. If $V_{GND} > V_{IN} - V_{IN(T+)}$ device stays off

V_{bb} disconnect with charged inductive load

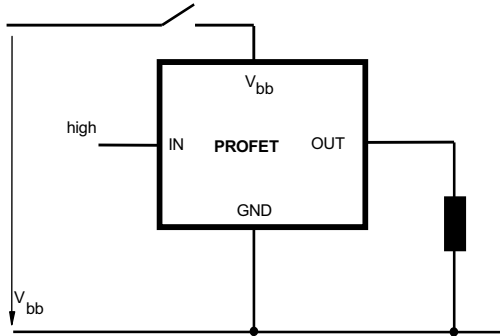

For inductive load currents up to the limits defined by Z_L (max. ratings and diagram on page 8) each switch is protected against loss of V_{bb} .

Consider at your PCB layout that in the case of V_{bb} disconnection with energized inductive load all the load current flows through the GND connection.

Inductive load switch-off energy dissipation

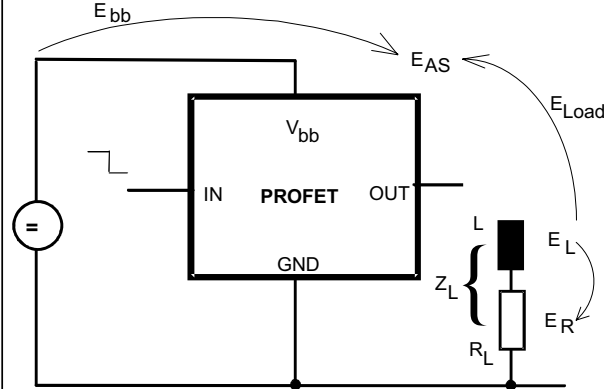

Energy stored in load inductance:

$$E_L = 1/2 \cdot L \cdot I_L^2$$

While demagnetizing load inductance, the energy dissipated in PROFET is

$$E_{AS} = E_{bb} + E_L - E_R = \int V_{ON(CL)} \cdot i_L(t) dt,$$

with an approximate solution for $R_L > 0 \Omega$:

$$E_{AS} = \frac{I_L \cdot L}{2 \cdot R_L} (V_{bb} + |V_{OUT(CL)}|) \ln \left(1 + \frac{I_L \cdot R_L}{|V_{OUT(CL)}|} \right)$$

Maximum allowable load inductance for a single switch off

$L = f(I_L)$; $T_{j,start} = 150^\circ\text{C}$, $V_{bb} = 12\text{ V}$, $R_L = 0 \Omega$

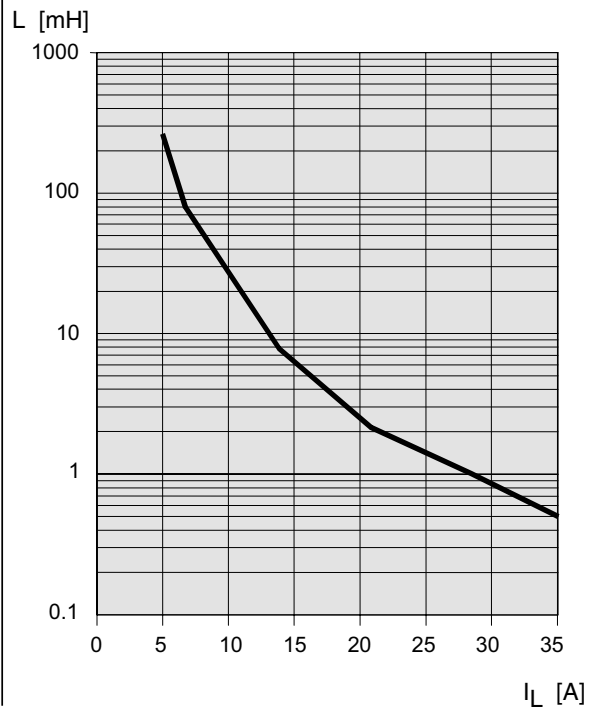

Typ. on-state resistance

$R_{ON} = f(V_{bb}, T_j)$; $I_L = 2\text{ A}$, $I_N = \text{high}$

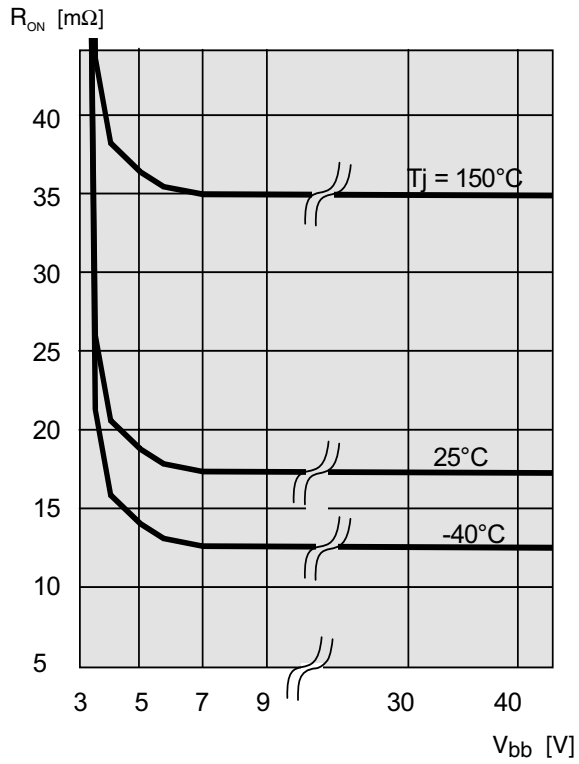

Typ. standby current

$I_{bb(off)} = f(T_j)$; $V_{bb} = 9 \dots 34\text{ V}$, $I_{N1,2} = \text{low}$

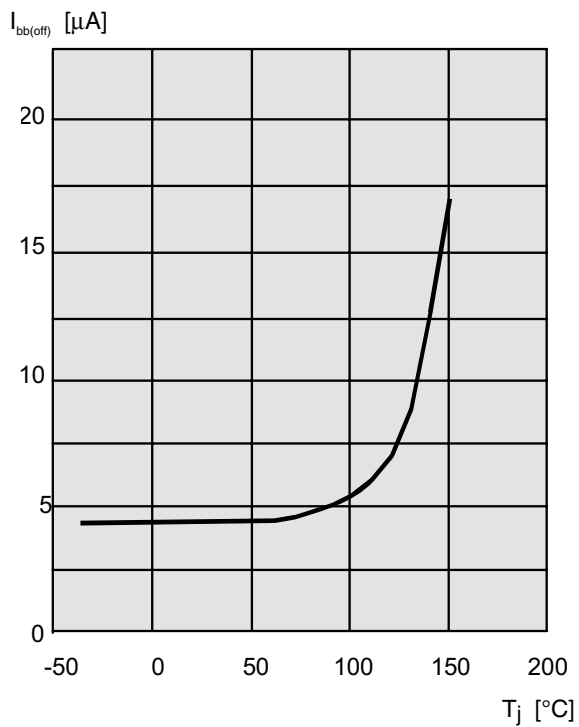

Timing diagrams

Figure 1a: V_{bb} turn on:



proper turn on under all conditions

Figure 2a: Switching a resistive load, turn-on/off time and slew rate definition:

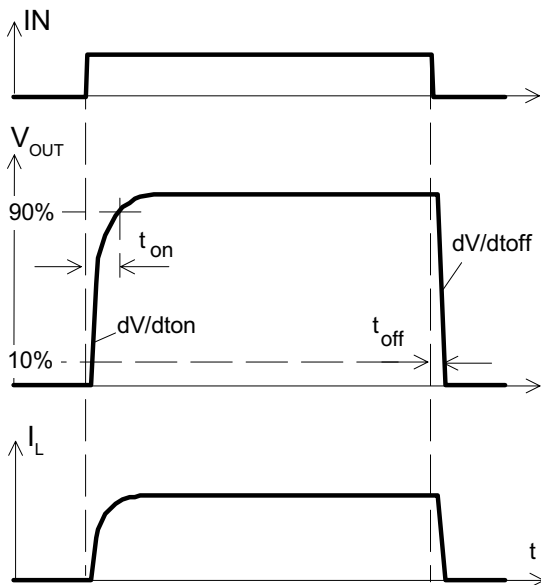

Figure 2b: Switching a lamp,

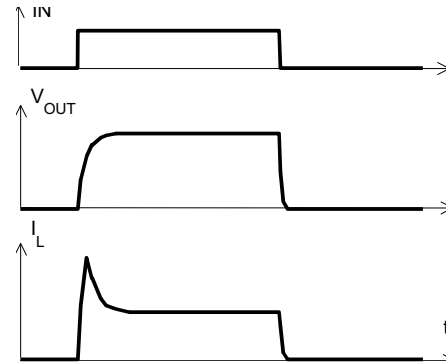
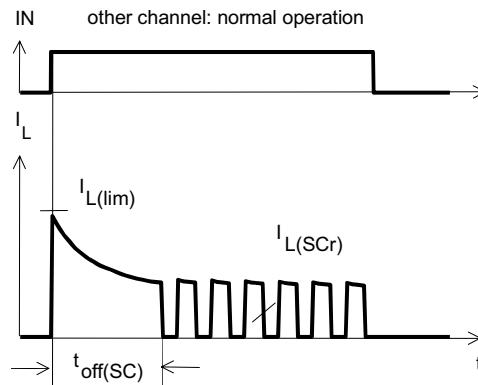
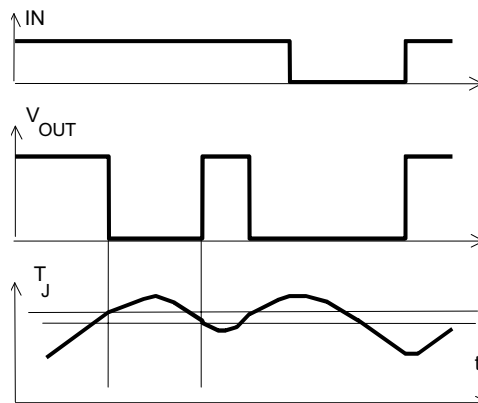

Figure 3a: Short circuit shut down by overtemperature, reset by cooling



Heating up may require several milliseconds, depending on external conditions

Figure 4a: Overtemperature: Reset if $T_j < T_{jt}$



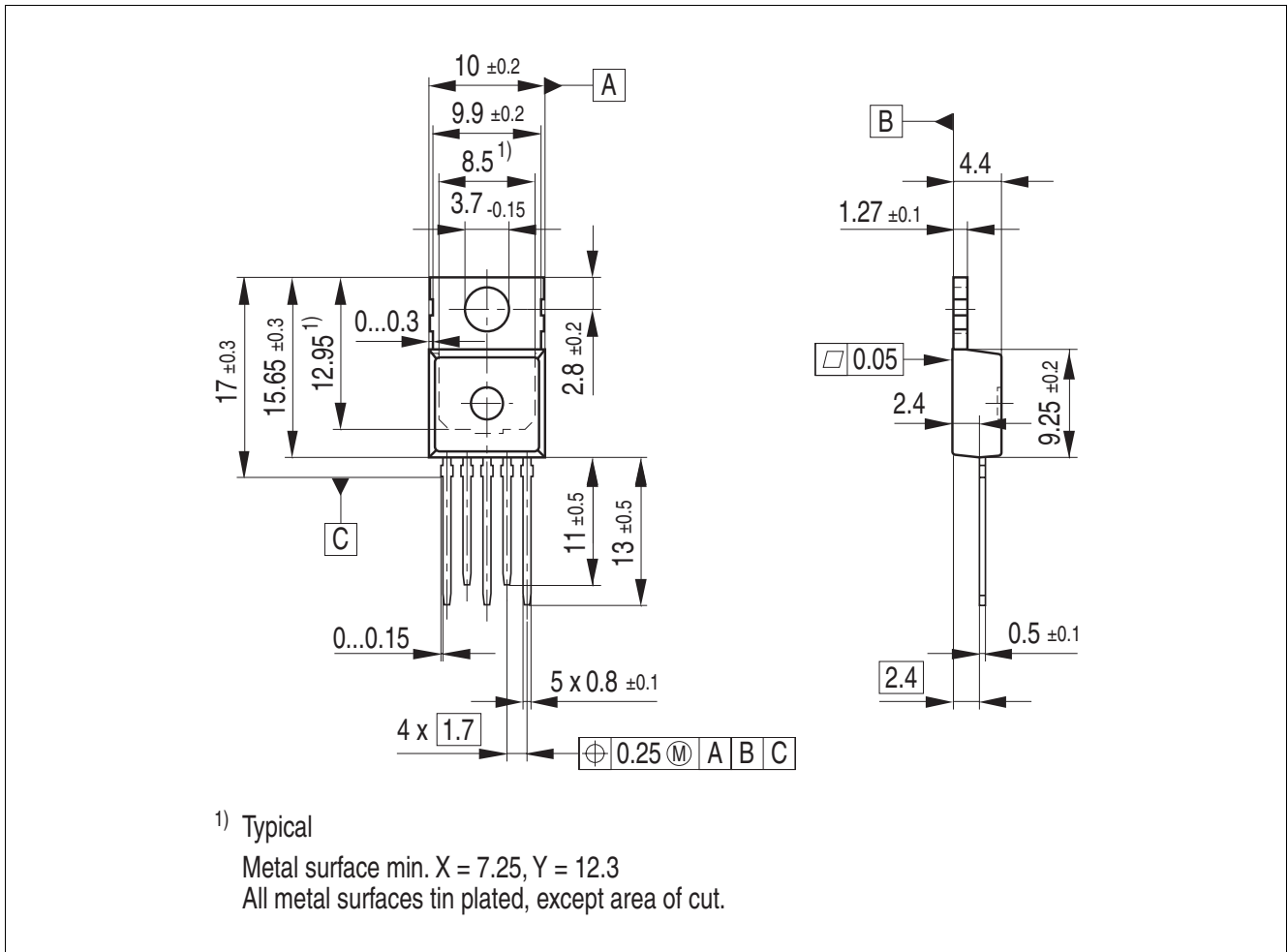

Figure 6: PG-TO220-5-12

Green Product (RoHS compliant)

To meet the world-wide customer requirements for environmentally friendly products and to be compliant with government regulations the device is available as a green product. Green products are RoHS-Compliant (i.e Pb-free finish on leads and suitable for Pb-free soldering according to IPC/JEDEC J-STD-020).

For further information on alternative packages, please visit our website:
<http://www.infineon.com/packages>.

Dimensions in mm

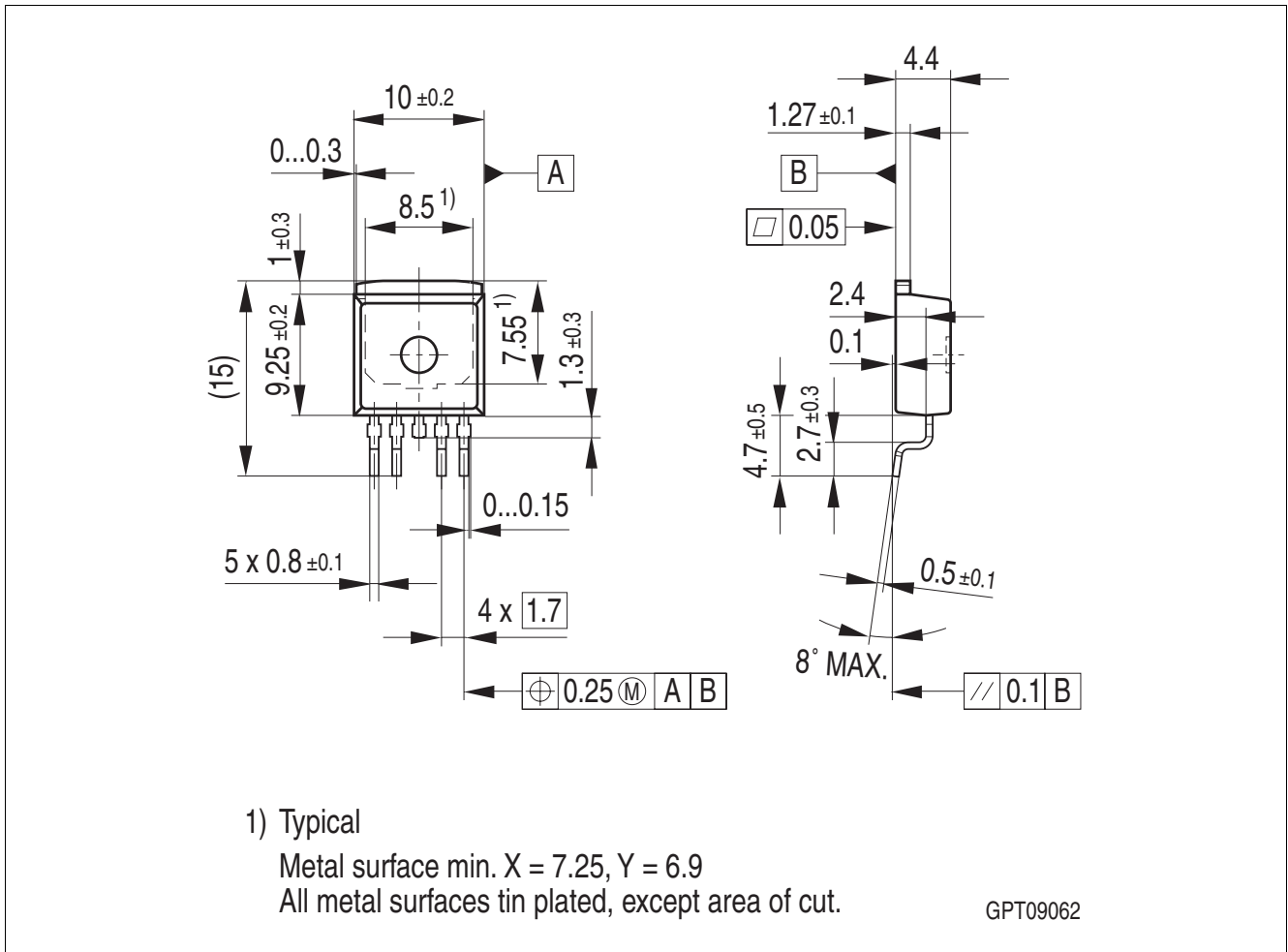

Figure 7: PG-TO263-5-2

Green Product (RoHS compliant)

To meet the world-wide customer requirements for environmentally friendly products and to be compliant with government regulations the device is available as a green product. Green products are RoHS-Compliant (i.e. Pb-free finish on leads and suitable for Pb-free soldering according to IPC/JEDEC J-STD-020).

For further information on alternative packages, please visit our website:
<http://www.infineon.com/packages>.

Dimensions in mm

Revision History

Revision	Date	Changes
1.11	2008-12-09	<p>RoHS-compliant PG-TO220 and PG-TO263 packages version of the BTS441T</p> <p>All pages: Infineon logo updated</p> <p>Page 1: Added "AEC qualified" and "RoHS" logo, added "Green Product (RoHS compliant)" and "AEC qualified" statement to feature list, package names changed to RoHS compliant versions, updated package drawing.</p> <p>Page 10-12: Package names changed to RoHS compliant versions (PG-TO220-5-11, PG-TO220-12 and PG-TO263-5-2), added "Green Product" description added Revision History added Legal Disclaimer</p>

Edition 2008-12-09

**Published by
Infineon Technologies AG
81726 Munich, Germany**

**© 2008 Infineon Technologies AG
All Rights Reserved.**

Legal Disclaimer

The information given in this document shall in no event be regarded as a guarantee of conditions or characteristics. With respect to any examples or hints given herein, any typical values stated herein and/or any information regarding the application of the device, Infineon Technologies hereby disclaims any and all warranties and liabilities of any kind, including without limitation, warranties of non-infringement of intellectual property rights of any third party.

Information

For further information on technology, delivery terms and conditions and prices, please contact the nearest Infineon Technologies Office (www.infineon.com).

Warnings

Due to technical requirements, components may contain dangerous substances. For information on the types in question, please contact the nearest Infineon Technologies Office.

Infineon Technologies components may be used in life-support devices or systems only with the express written approval of Infineon Technologies, if a failure of such components can reasonably be expected to cause the failure of that life-support device or system or to affect the safety or effectiveness of that device or system. Life support devices or systems are intended to be implanted in the human body or to support and/or maintain and sustain and/or protect human life. If they fail, it is reasonable to assume that the health of the user or other persons may be endangered.

Looking for pricing, stock, or lifecycle information?

Click below to explore more details on WIN SOURCE:

-  [View BTS441TSAKSA1](#) on WIN SOURCE
-  [Infineon Technologies](#) Information

Optimize Your Supply Chain with WIN SOURCE Solutions

-  Global Sourcing Solution
-  Obsolete Management
-  Cost Control Management
-  Shortage Management
-  Alternative Solution
-  Excess Inventory Management