



THE DATASHEET OF BUX84-S





-
- 40 W at 25°C Case Temperature
- 2 A Continuous Collector Current
- 3 A Peak Collector Current
- Typical $t_f = 200$ ns at 25°C

TO-220 PACKAGE
(TOP VIEW)

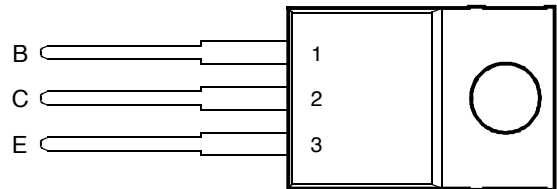

Pin 2 is in electrical contact with the mounting base.

MDTRACA



This series is obsolete and not recommended for new designs.

absolute maximum ratings at 25°C case temperature (unless otherwise noted)

RATING	SYMBOL	VALUE	UNIT
Collector-base voltage ($I_E = 0$)	V_{CB0}	800	V
Collector-emitter voltage ($V_{BE} = 0$)	V_{CES}	800	V
Collector-emitter voltage ($I_B = 0$)	V_{CEO}	400	V
Continuous collector current	I_C	2	A
Peak collector current (see Note 1)	I_{CM}	3	A
Continuous device dissipation at (or below) 25°C case temperature	P_{tot}	40	W
Operating junction temperature range	T_j	-65 to +150	°C
Storage temperature range	T_{stg}	-65 to +150	°C

NOTE 1: This value applies for $t_p \leq 2$ ms, duty cycle $\leq 2\%$

OBSOLETE

PRODUCT INFORMATION

AUGUST 1978 - REVISED SEPTEMBER 2002
Specifications are subject to change without notice.

BUX84

NPN SILICON POWER TRANSISTOR

BOURNS®

electrical characteristics at 25°C case temperature (unless otherwise noted)

PARAMETER	TEST CONDITIONS	MIN	TYP	MAX	UNIT
$V_{CEO(sus)}$ Collector-emitter sustaining voltage	$I_C = 0.1\text{ A}$ $L = 25\text{ mH}$ (see Note 2)	400			V
I_{CES} Collector-emitter cut-off current	$V_{CE} = 800\text{ V}$ $V_{BE} = 0$ $V_{CE} = 800\text{ V}$ $V_{BE} = 0$ $T_C = 125^\circ\text{C}$			0.2 1	mA
I_{EBO} Emitter cut-off current	$V_{EB} = 5\text{ V}$ $I_C = 0$			1	mA
h_{FE} Forward current transfer ratio	$V_{CE} = 5\text{ V}$ $I_C = 0.1\text{ A}$ (see Notes 3 and 4)		35		
$V_{CE(sat)}$ Collector-emitter saturation voltage	$I_B = 0.03\text{ A}$ $I_C = 0.3\text{ A}$ $I_B = 0.2\text{ A}$ $I_C = 1\text{ A}$ (see Notes 3 and 4)			0.8 1	V
$V_{BE(sat)}$ Base-emitter saturation voltage	$I_B = 0.2\text{ A}$ $I_C = 1\text{ A}$ (see Notes 3 and 4)			1.1	V
f_t Current gain bandwidth product	$V_{CE} = 10\text{ V}$ $I_C = 0.2\text{ A}$		12		MHz
C_{ob} Output capacitance	$V_{CB} = 20\text{ V}$ $I_E = 0$ $f = 0.1\text{ MHz}$		60		pF

NOTES: 2. Inductive loop switching measurement.

3. These parameters must be measured using pulse techniques, $t_p = 300\text{ }\mu\text{s}$, duty cycle $\leq 2\%$.

4. These parameters must be measured using voltage-sensing contacts, separate from the current carrying contacts.

5. To obtain f_t the $[h_{FE}]$ response is extrapolated at the rate of -6 dB per octave from $f = 1\text{ MHz}$ to the frequency at which $[h_{FE}] = 1$.

thermal characteristics

PARAMETER	MIN	TYP	MAX	UNIT
$R_{\theta JC}$ Junction to case thermal resistance			2.5	$^\circ\text{C/W}$

resistive-load-switching characteristics at 25°C case temperature (unless otherwise noted)

PARAMETER	TEST CONDITIONS †	MIN	TYP	MAX	UNIT
t_{on} Turn on time	$I_C = 1\text{ A}$ $I_{B(on)} = 0.2\text{ A}$ $I_{B(off)} = -0.4\text{ A}$		0.25	0.5	μs
t_s Storage time	$V_{CC} = 250\text{ V}$ (see Figures 1 and 2)		1.8		μs
t_f Fall time	$I_C = 1\text{ A}$ $I_{B(on)} = 0.2\text{ A}$ $I_{B(off)} = -0.4\text{ A}$		0.2		μs
t_f Fall time	$V_{CC} = 250\text{ V}$ $T_C = 95^\circ\text{C}$			0.4	μs

† Voltage and current values shown are nominal; exact values vary slightly with transistor parameters.

PRODUCT INFORMATION

PARAMETER MEASUREMENT INFORMATION

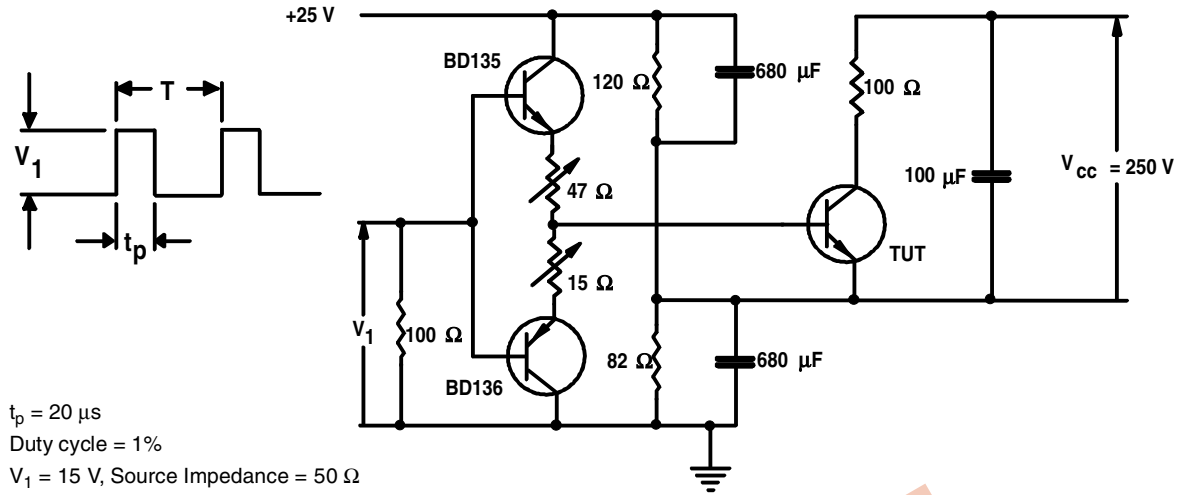

Figure 1. Resistive-Load Switching Test Circuit

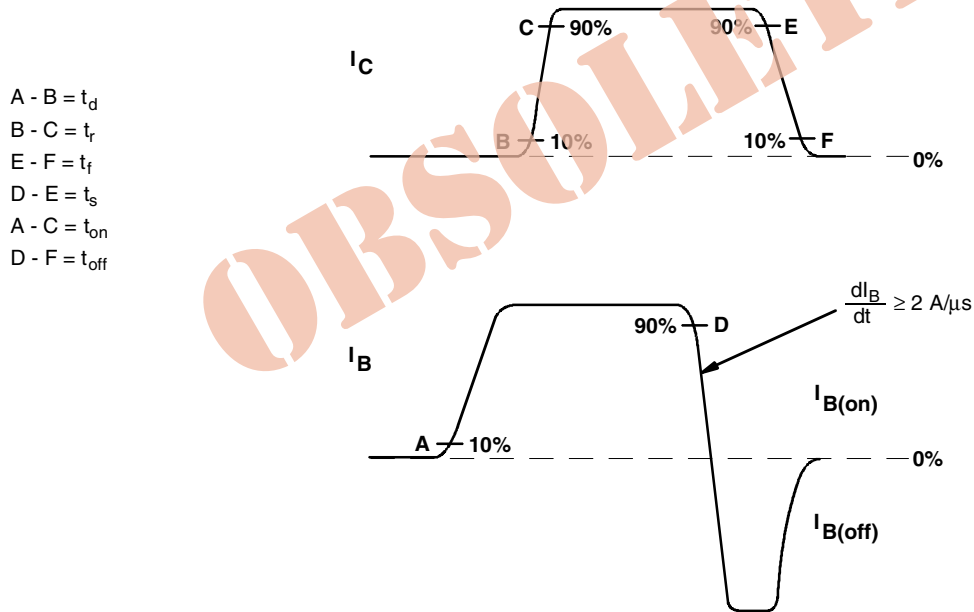

Figure 2. Resistive-Load Switching Waveforms

PRODUCT INFORMATION

AUGUST 1978 - REVISED SEPTEMBER 2002
 Specifications are subject to change without notice.

TYPICAL CHARACTERISTICS

TYPICAL DC CURRENT GAIN
vs
COLLECTOR CURRENT

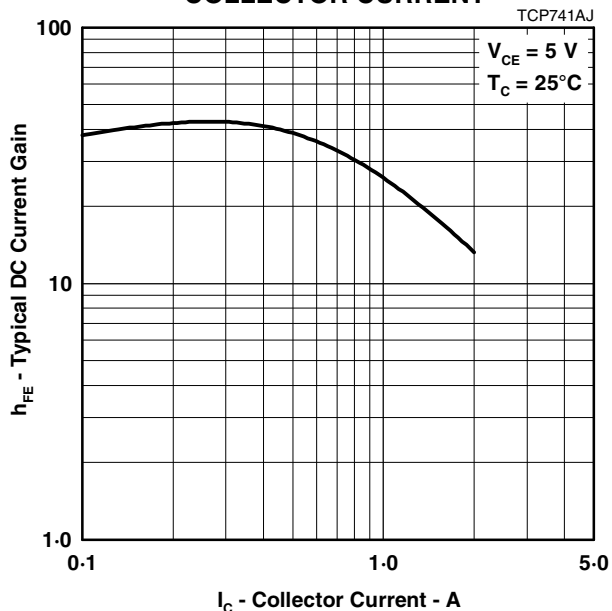

Figure 3.

COLLECTOR CUT-OFF CURRENT
vs
CASE TEMPERATURE

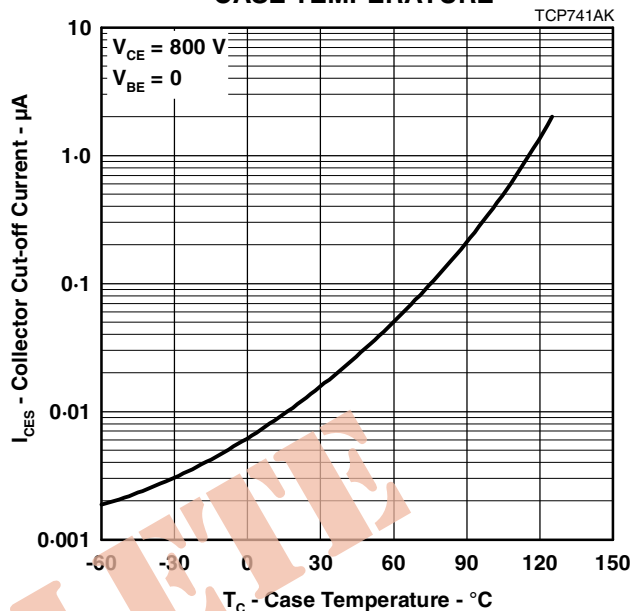

Figure 4.

MAXIMUM SAFE OPERATING REGIONS

MAXIMUM FORWARD-BIAS
SAFE OPERATING AREA

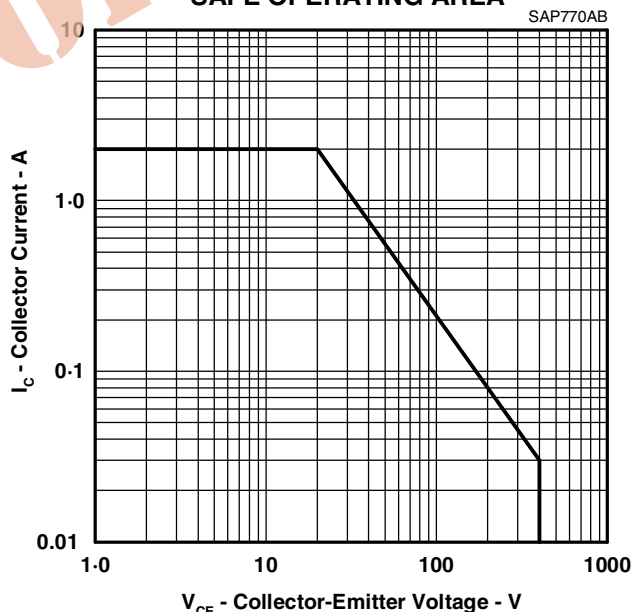

Figure 5.

PRODUCT INFORMATION

AUGUST 1978 - REVISED SEPTEMBER 2002
 Specifications are subject to change without notice.

THERMAL INFORMATION

**THERMAL RESPONSE JUNCTION TO CASE
vs
POWER PULSE DURATION**

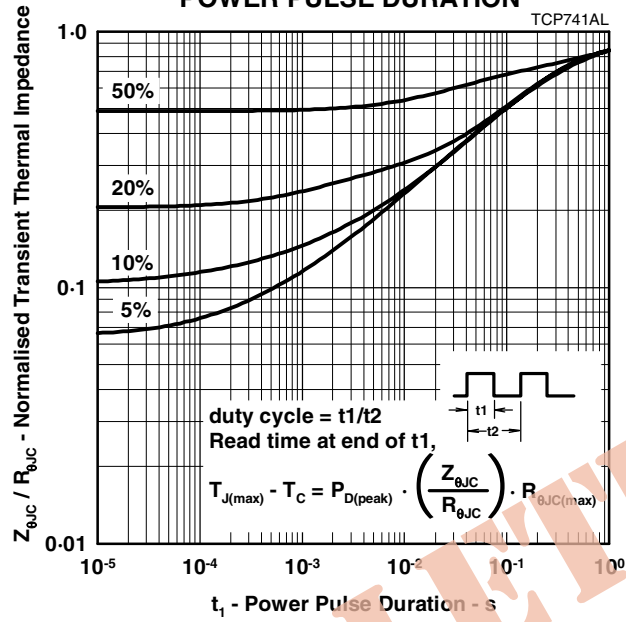



Figure 6.

PRODUCT INFORMATION

AUGUST 1978 - REVISED SEPTEMBER 2002
 Specifications are subject to change without notice.

Looking for pricing, stock, or lifecycle information?

Click below to explore more details on WIN SOURCE:

 [View BUX84-S on WIN SOURCE](#)

 [Bourns Inc. Information](#)

Optimize Your Supply Chain with WIN SOURCE Solutions

-  Global Sourcing Solution
-  Obsolete Management
-  Cost Control Management
-  Shortage Management
-  Alternative Solution
-  Excess Inventory Management