

Features

- High Performance, Low Power Atmel® 32-bit AVR® Microcontroller
 - Compact Single-cycle RISC Instruction Set including DSP Instructions
 - Read Modify Write Instructions and Atomic Bit Manipulation
 - Performance
 - Up to 64DMIPS Running at 50MHz from Flash (1 Flash Wait State)
 - Up to 36DMIPS Running at 25MHz from Flash (0 Flash Wait State)
 - Memory Protection Unit (MPU)
 - Secure Access Unit (SAU) providing User Defined Peripheral Protection
- picoPower® Technology for Ultra-low Power Consumption
- Multi-hierarchy Bus System
 - High-performance Data Transfers on Separate Buses for Increased Performance
 - 12 Peripheral DMA Channels improve Speed for Peripheral Communication
- Internal High-speed Flash
 - 64Kbytes, 32Kbytes, and 16Kbytes Versions
 - Single-cycle Access up to 25MHz
 - FlashVault™ Technology Allows Pre-programmed Secure Library Support for End User Applications
 - Prefetch Buffer Optimizing Instruction Execution at Maximum Speed
 - 100,000 Write Cycles, 15-year Data Retention Capability
 - Flash Security Locks and User Defined Configuration Area
- Internal High-speed SRAM, Single-cycle Access at Full Speed
 - 16Kbytes (64Kbytes and 32Kbytes Flash), or 8Kbytes (16Kbytes Flash)
- Interrupt Controller (INTC)
 - Autovectored Low Latency Interrupt Service with Programmable Priority
- External Interrupt Controller (EIC)
- Peripheral Event System for Direct Peripheral to Peripheral Communication
- System Functions
 - Power and Clock Manager
 - SleepWalking™ Power Saving Control
 - Internal System RC Oscillator (RCSYS)
 - 32KHz Oscillator
 - Multipurpose Oscillator and Digital Frequency Locked Loop (DFLL)
- Windowed Watchdog Timer (WDT)
- Asynchronous Timer (AST) with Real-time Clock Capability
 - Counter or Calendar Mode Supported
- Frequency Meter (FREQM) for Accurate Measuring of Clock Frequency
- Six 16-bit Timer/Counter (TC) Channels
 - External Clock Inputs, PWM, Capture and Various Counting Capabilities
- PWM Channels on All I/O Pins (PWMA)
 - 8-bit PWM up to 150MHz Source Clock
- Four Universal Synchronous/Asynchronous Receiver/Transmitters (USART)
 - Independent Baudrate Generator, Support for SPI
 - Support for Hardware Handshaking
- One Master/Slave Serial Peripheral Interfaces (SPI) with Chip Select Signals
 - Up to 15 SPI Slaves can be Addressed
- Two Master and Two Slave Two-wire Interface (TWI), 400kbit/s I²C-compatible
- One 8-channel Analog-to-digital Converter (ADC) with up to 12 Bits Resolution
 - Internal Temperature Sensor



32-bit AVR® Microcontroller

AT32UC3L064
AT32UC3L032
AT32UC3L016

Preliminary

32099G-06/2011



- **Eight Analog Comparators (AC) with Optional Window Detection**
- **Capacitive Touch (CAT) Module**
 - **Hardware Assisted Atmel® AVR® QTouch® and Atmel® AVR® QMatrix® Touch Acquisition**
 - **Supports QTouch and QMatrix Capture from Capacitive Touch Sensors**
- **QTouch Library Support**
 - **Capacitive Touch Buttons, Sliders, and Wheels**
 - **QTouch and QMatrix Acquisition**
- **On-chip Non-intrusive Debug System**
 - **Nexus Class 2+, Runtime Control, Non-intrusive Data and Program Trace**
 - **aWire™ Single-pin Programming Trace and Debug Interface Muxed with Reset Pin**
 - **NanoTrace™ Provides Trace Capabilities through JTAG or aWire Interface**
- **48-pin TQFP/QFN/TLLGA (36 GPIO Pins)**
- **Five High-drive I/O Pins**
- **Single 1.62-3.6 V Power Supply**

1. Description

The Atmel® AVR® AT32UC3L is a complete System-on-chip microcontroller based on the AVR32 UC RISC processor running at frequencies up to 50MHz. AVR32 UC is a high-performance 32-bit RISC microprocessor core, designed for cost-sensitive embedded applications, with particular emphasis on low power consumption, high code density, and high performance.

The processor implements a Memory Protection Unit (MPU) and a fast and flexible interrupt controller for supporting modern operating systems and real-time operating systems. The Secure Access Unit (SAU) is used together with the MPU to provide the required security and integrity.

Higher computation capability is achieved using a rich set of DSP instructions.

The AT32UC3L embeds state-of-the-art picoPower technology for ultra-low power consumption. Combined power control techniques are used to bring active current consumption down to 165µA/MHz, and leakage down to 9nA while still retaining a bank of backup registers. The device allows a wide range of trade-offs between functionality and power consumption, giving the user the ability to reach the lowest possible power consumption with the feature set required for the application.

The Peripheral Direct Memory Access (DMA) controller enables data transfers between peripherals and memories without processor involvement. The Peripheral DMA controller drastically reduces processing overhead when transferring continuous and large data streams.

The AT32UC3L incorporates on-chip Flash and SRAM memories for secure and fast access. The FlashVault technology allows secure libraries to be programmed into the device. The secure libraries can be executed while the CPU is in Secure State, but not read by non-secure software in the device. The device can thus be shipped to end customers, who will be able to program their own code into the device, accessing the secure libraries, but without risk of compromising the proprietary secure code.

The Peripheral Event System allows peripherals to receive, react to, and send peripheral events without CPU intervention. Asynchronous interrupts allow advanced peripheral operation in low power sleep modes.

The Power Manager improves design flexibility and security. The Power Manager supports SleepWalking functionality, by which a module can be selectively activated based on peripheral events, even in sleep modes where the module clock is stopped. Power monitoring is supported by on-chip Power-on Reset (POR), Brown-out Detector (BOD), and Supply Monitor (SM). The device features several oscillators, such as Digital Frequency Locked Loop (DFLL), Oscillator 0 (OSC0), and system RC oscillator (RCSYS). Either of these oscillators can be used as source for the system clock. The DFLL is a programmable internal oscillator from 40 to 150MHz. It can be tuned to a high accuracy if an accurate oscillator is running, e.g. the 32KHz crystal oscillator.

The Watchdog Timer (WDT) will reset the device unless it is periodically serviced by the software. This allows the device to recover from a condition that has caused the system to be unstable.

The Asynchronous Timer (AST) combined with the 32KHz crystal oscillator supports powerful real-time clock capabilities, with a maximum timeout of up to 136 years. The AST can operate in counter mode or calendar mode.

The Frequency Meter (FREQM) allows accurate measuring of a clock frequency by comparing it to a known reference clock.

The device includes six identical 16-bit Timer/Counter (TC) channels. Each channel can be independently programmed to perform frequency measurement, event counting, interval measurement, pulse generation, delay timing, and pulse width modulation.

The Pulse Width Modulation controller (PWMA) provides 8-bit PWM channels which can be synchronized and controlled from a common timer. One PWM channel is available for each I/O pin on the device, enabling applications that require multiple PWM outputs, such as LCD backlight control. The PWM channels can operate independently, with duty cycles set independently from each other, or in interlinked mode, with multiple channels changed at the same time.

The AT32UC3L also features many communication interfaces for communication intensive applications like USART, SPI, or TWI. The USART supports different communication modes, like SPI Mode and LIN Mode.

A general purpose 8-channel ADC is provided, as well as eight analog comparators (AC). The ADC can operate in 10-bit mode at full speed or in enhanced mode at reduced speed, offering up to 12-bit resolution. The ADC also provides an internal temperature sensor input channel. The analog comparators can be paired to detect when the sensing voltage is within or outside the defined reference window.

The Capacitive Touch (CAT) module senses touch on external capacitive touch sensors, using the QTouch technology. Capacitive touch sensors use no external mechanical components, unlike normal push buttons, and therefore demand less maintenance in the user application. The CAT module allows up to 17 touch sensors, or up to 16 by 8 matrix sensors to be interfaced. One touch sensor can be configured to operate autonomously without software interaction, allowing wakeup from sleep modes when activated.

Atmel offers the QTouch library for embedding capacitive touch buttons, sliders, and wheels functionality into AVR microcontrollers. The patented charge-transfer signal acquisition offers robust sensing and includes fully debounced reporting of touch keys as well as Adjacent Key Suppression® (AKS®) technology for unambiguous detection of key events. The easy-to-use QTouch Suite toolchain allows you to explore, develop, and debug your own touch applications.

The AT32UC3L integrates a class 2+ Nexus 2.0 On-chip Debug (OCD) System, with non-intrusive real-time trace, full-speed read/write memory access, in addition to basic runtime control. The NanoTrace interface enables trace feature for aWire- or JTAG-based debuggers. The single-pin aWire interface allows all features available through the JTAG interface to be accessed through the RESET pin, allowing the JTAG pins to be used for GPIO or peripherals.

2. Overview

2.1 Block Diagram

Figure 2-1. Block Diagram

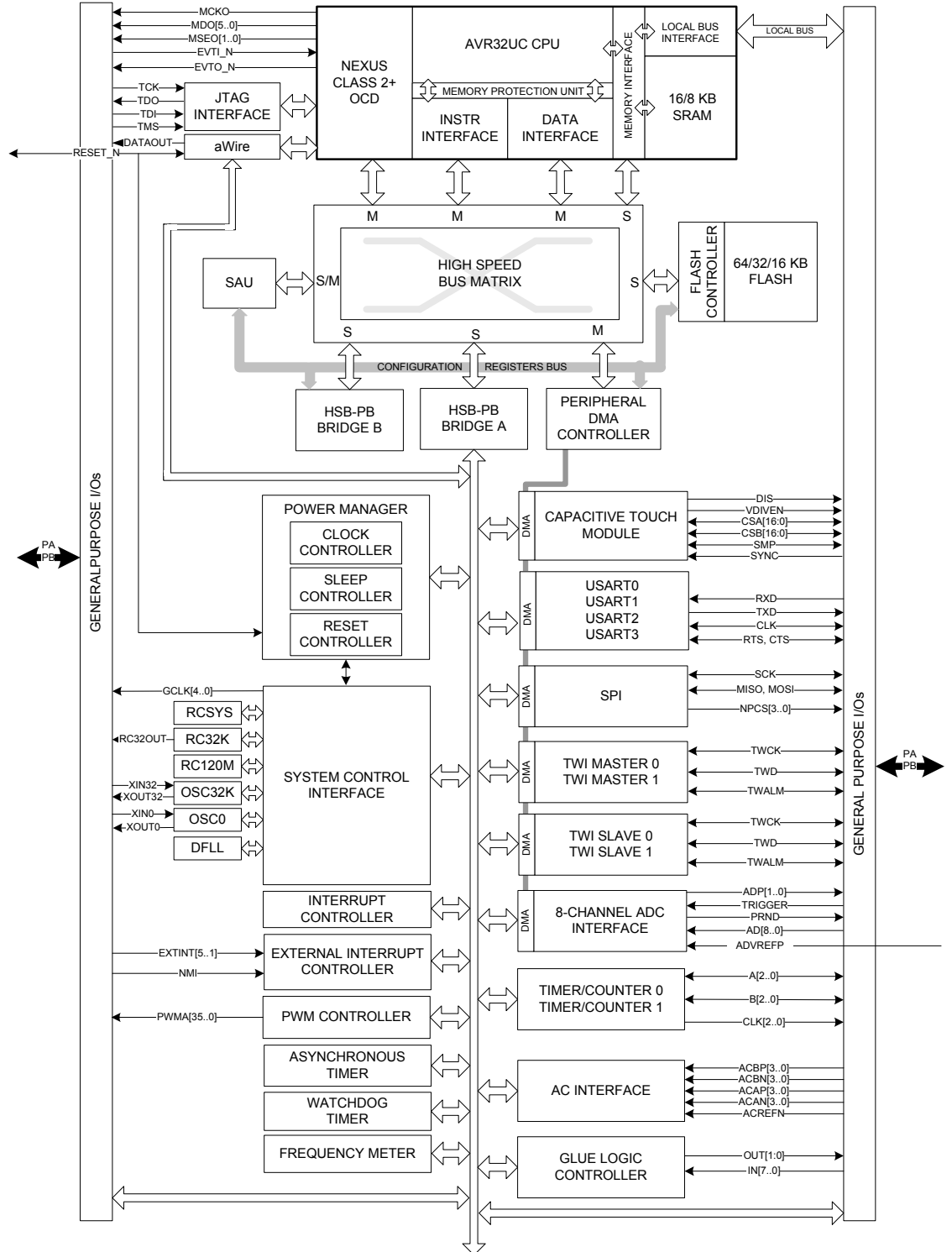

2.2 Configuration Summary

Table 2-1. Configuration Summary

Feature	AT32UC3L064	AT32UC3L032	AT32UC3L016
Flash	64KB	32KB	16KB
SRAM	16KB	16KB	8KB
GPIO	36		
High-drive pins	5		
External Interrupts	6		
TWI	2		
USART	4		
Peripheral DMA Channels	12		
Peripheral Event System	1		
SPI	1		
Asynchronous Timers	1		
Timer/Counter Channels	6		
PWM channels	36		
Frequency Meter	1		
Watchdog Timer	1		
Power Manager	1		
Secure Access Unit	1		
Glue Logic Controller	1		
Oscillators	Digital Frequency Locked Loop 40-150MHz (DFLL) Crystal Oscillator 3-16MHz (OSC0) Crystal Oscillator 32KHz (OSC32K) RC Oscillator 120MHz (RC120M) RC Oscillator 115kHz (RCSYS) RC Oscillator 32kHz (RC32K)		
ADC	8-channel 12-bit		
Temperature Sensor	1		
Analog Comparators	8		
Capacitive Touch Module	1		
JTAG	1		
aWire	1		
Max Frequency	50MHz		
Packages	TQFP48/QFN48/TLLGA48		

3. Package and Pinout

3.1 Package

The device pins are multiplexed with peripheral functions as described in [Section 3.2](#).

Figure 3-1. TQFP48/QFN48 Pinout

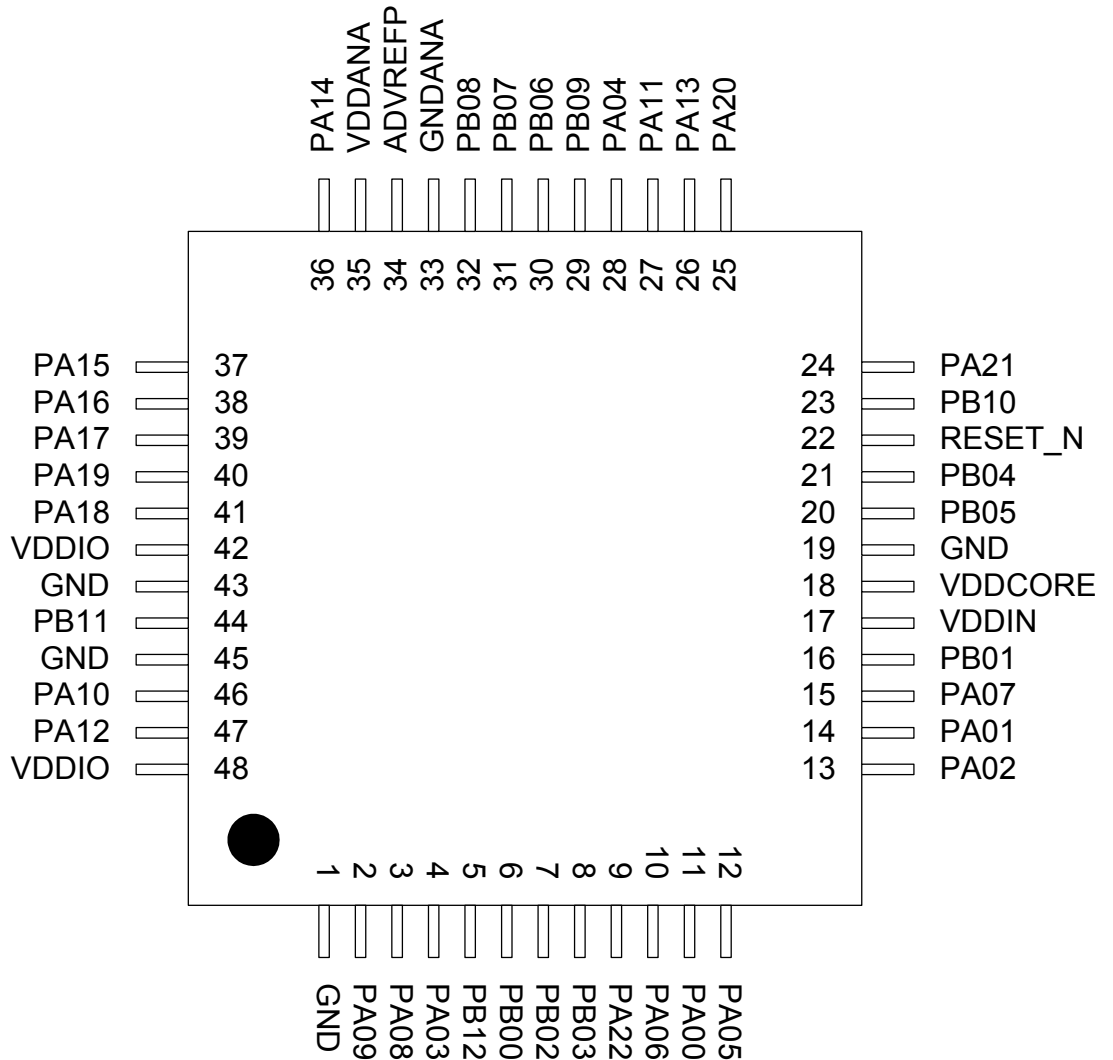
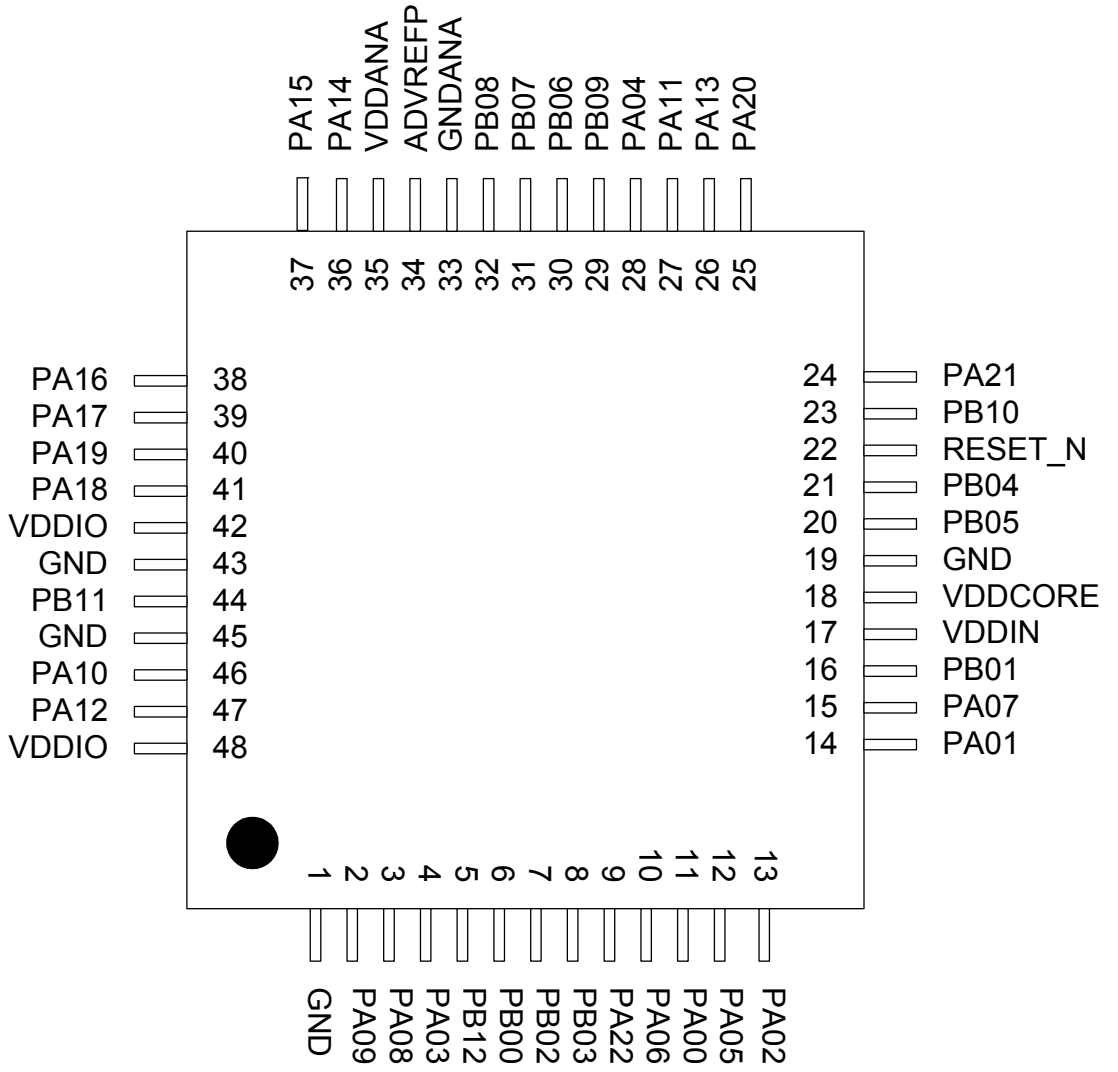

Figure 3-2. TLLGA48 Pinout



3.2 Peripheral Multiplexing on I/O lines

3.2.1 Multiplexed signals

Each GPIO line can be assigned to one of the peripheral functions. The following table describes the peripheral signals multiplexed to the GPIO lines.

Table 3-1. GPIO Controller Function Multiplexing

48-pin	PIN	GPIO	Supply	Pin Type	GPIO Function							
					A	B	C	D	E	F	G	H
11	PA00	0	VDDIO	Normal I/O	USART0 TXD	USART1 RTS	SPI NPCS[2]		PWMA PWMA[0]		SCIF GCLK[0]	CAT CSA[2]
14	PA01	1	VDDIO	Normal I/O	USART0 RXD	USART1 CTS	SPI NPCS[3]	USART1 CLK	PWMA PWMA[1]	ACIFB ACAP[0]	TWIMS0 TWALM	CAT CSA[1]
13	PA02	2	VDDIO	High-drive I/O	USART0 RTS	ADCIFB TRIGGER	USART2 TXD	TC0 A0	PWMA PWMA[2]	ACIFB ACBP[0]	USART0 CLK	CAT CSA[3]
4	PA03	3	VDDIO	Normal I/O	USART0 CTS	SPI NPCS[1]	USART2 TXD	TC0 B0	PWMA PWMA[3]	ACIFB ACBN[3]	USART0 CLK	CAT CSB[3]
28	PA04	4	VDDIO	Normal I/O	SPI MISO	TWIMS0 TWCK	USART1 RXD	TC0 B1	PWMA PWMA[4]	ACIFB ACBP[1]		CAT CSA[7]
12	PA05	5	VDDIO	Normal I/O (TWI)	SPI MOSI	TWIMS1 TWCK	USART1 TXD	TC0 A1	PWMA PWMA[5]	ACIFB ACBN[0]	TWIMS0 TWD	CAT CSB[7]
10	PA06	6	VDDIO	High-drive I/O, 5V tolerant	SPI SCK	USART2 TXD	USART1 CLK	TC0 B0	PWMA PWMA[6]		SCIF GCLK[1]	CAT CSB[1]
15	PA07	7	VDDIO	Normal I/O (TWI)	SPI NPCS[0]	USART2 RXD	TWIMS1 TWALM	TWIMS0 TWCK	PWMA PWMA[7]	ACIFB ACAN[0]	EIC EXTINT[0]	CAT CSB[2]
3	PA08	8	VDDIO	High-drive I/O	USART1 TXD	SPI NPCS[2]	TC0 A2	ADCIFB ADP[0]	PWMA PWMA[8]			CAT CSA[4]
2	PA09	9	VDDIO	High-drive I/O	USART1 RXD	SPI NPCS[3]	TC0 B2	ADCIFB ADP[1]	PWMA PWMA[9]	SCIF GCLK[2]	EIC EXTINT[1]	CAT CSB[4]
46	PA10	10	VDDIO	Normal I/O	TWIMS0 TWD		TC0 A0		PWMA PWMA[10]	ACIFB ACAP[1]	SCIF GCLK[2]	CAT CSA[5]
27	PA11	11	VDDIN	Normal I/O					PWMA PWMA[11]			
47	PA12	12	VDDIO	Normal I/O	ADCIFB PRND	USART2 CLK	TC0 CLK1	CAT SMP	PWMA PWMA[12]	ACIFB ACAN[1]	SCIF GCLK[3]	CAT CSB[5]
26	PA13	13	VDDIN	Normal I/O	GLOC OUT[0]	GLOC IN[7]	TC0 A0	SCIF GCLK[2]	PWMA PWMA[13]	CAT SMP	EIC EXTINT[2]	CAT CSA[0]
36	PA14	14	VDDIO	Normal I/O	ADCIFB AD[0]	TC0 CLK2	USART2 RTS	CAT SMP	PWMA PWMA[14]		SCIF GCLK[4]	CAT CSA[6]
37	PA15	15	VDDIO	Normal I/O	ADCIFB AD[1]	TC0 CLK1		GLOC IN[6]	PWMA PWMA[15]	CAT SYNC	EIC EXTINT[3]	CAT CSB[6]
38	PA16	16	VDDIO	Normal I/O	ADCIFB AD[2]	TC0 CLK0		GLOC IN[5]	PWMA PWMA[16]	ACIFB ACREFN	EIC EXTINT[4]	CAT CSA[8]
39	PA17	17	VDDIO	Normal I/O (TWI)		TC0 A1	USART2 CTS	TWIMS1 TWD	PWMA PWMA[17]	CAT SMP	CAT DIS	CAT CSB[8]
41	PA18	18	VDDIO	Normal I/O	ADCIFB AD[4]	TC0 B1		GLOC IN[4]	PWMA PWMA[18]	CAT SYNC	EIC EXTINT[5]	CAT CSB[0]

Table 3-1. GPIO Controller Function Multiplexing

40	PA19	19	VDDIO	Normal I/O	ADCIFB AD[5]		TC0 A2	TWIMS1 TWALM	PWMA PWMA[19]		CAT SYNC	CAT CSA[10]
25	PA20	20	VDDIN	Normal I/O	USART2 TXD		TC0 A1	GLOC IN[3]	PWMA PWMA[20]	SCIF RC32OUT		CAT CSA[12]
24	PA21	21	VDDIN	Normal I/O (TWI, 5V tolerant SMBus)	USART2 RXD	TWIMS0 TWD	TC0 B1	ADCIFB TRIGGER	PWMA PWMA[21]	PWMA PWMAOD[21]	SCIF GCLK[0]	CAT SMP
9	PA22	22	VDDIO	Normal I/O	USART0 CTS	USART2 CLK	TC0 B2	CAT SMP	PWMA PWMA[22]	ACIFB ACBN[2]		CAT CSB[10]
6	PB00	32	VDDIO	Normal I/O	USART3 TXD	ADCIFB ADP[0]	SPI NPCS[0]	TC0 A1	PWMA PWMA[23]	ACIFB ACAP[2]	TC1 A0	CAT CSA[9]
16	PB01	33	VDDIO	High-drive I/O	USART3 RXD	ADCIFB ADP[1]	SPI SCK	TC0 B1	PWMA PWMA[24]		TC1 A1	CAT CSB[9]
7	PB02	34	VDDIO	Normal I/O	USART3 RTS	USART3 CLK	SPI MISO	TC0 A2	PWMA PWMA[25]	ACIFB ACAN[2]	SCIF GCLK[1]	CAT CSB[11]
8	PB03	35	VDDIO	Normal I/O	USART3 CTS	USART3 CLK	SPI MOSI	TC0 B2	PWMA PWMA[26]	ACIFB ACBP[2]	TC1 A2	CAT CSA[11]
21	PB04	36	VDDIN	Normal I/O (TWI, 5V tolerant SMBus)	TC1 A0	USART1 RTS	USART1 CLK	TWIMS0 TWALM	PWMA PWMA[27]	PWMA PWMAOD[27]	TWIMS1 TWCK	CAT CSA[14]
20	PB05	37	VDDIN	Normal I/O (TWI, 5V tolerant SMBus)	TC1 B0	USART1 CTS	USART1 CLK	TWIMS0 TWCK	PWMA PWMA[28]	PWMA PWMAOD[28]	SCIF GCLK[3]	CAT CSB[14]
30	PB06	38	VDDIO	Normal I/O	TC1 A1	USART3 TXD	ADCIFB AD[6]	GLOC IN[2]	PWMA PWMA[29]	ACIFB ACAN[3]	EIC EXTINT[0]	CAT CSB[13]
31	PB07	39	VDDIO	Normal I/O	TC1 B1	USART3 RXD	ADCIFB AD[7]	GLOC IN[1]	PWMA PWMA[30]	ACIFB ACAP[3]	EIC EXTINT[1]	CAT CSA[13]
32	PB08	40	VDDIO	Normal I/O	TC1 A2	USART3 RTS	ADCIFB AD[8]	GLOC IN[0]	PWMA PWMA[31]	CAT SYNC	EIC EXTINT[2]	CAT CSB[12]
29	PB09	41	VDDIO	Normal I/O	TC1 B2	USART3 CTS	USART3 CLK		PWMA PWMA[32]	ACIFB ACBN[1]	EIC EXTINT[3]	CAT CSB[15]
23	PB10	42	VDDIN	Normal I/O	TC1 CLK0	USART1 TXD	USART3 CLK	GLOC OUT[1]	PWMA PWMA[33]		EIC EXTINT[4]	CAT CSB[16]
44	PB11	43	VDDIO	Normal I/O	TC1 CLK1	USART1 RXD		ADCIFB TRIGGER	PWMA PWMA[34]	CAT VDIVEN	EIC EXTINT[5]	CAT CSA[16]
5	PB12	44	VDDIO	Normal I/O	TC1 CLK2		TWIMS1 TWALM	CAT SYNC	PWMA PWMA[35]	ACIFB ACBP[3]	SCIF GCLK[4]	CAT CSA[15]

See [Section 3.3](#) for a description of the various peripheral signals.

Refer to ["Electrical Characteristics"](#) on page 41 for a description of the electrical properties of the pin types used.

3.2.1.1 TWI, 5V Tolerant, and SMBUS Pins

Some Normal I/O pins have TWI, 5V Tolerant, and SMBUS features. These features are available only when TWI functions or the PWMAOD function of the PWMA are selected on these pins.

Refer to the ["TWI Pin Characteristics\(1\)" on page 49](#) for a description of the electrical properties of the TWI, 5V Tolerant, and SMBUS pins.

3.2.2 Peripheral Functions

Each GPIO line can be assigned to one of several peripheral functions. The following table describes how the various peripheral functions are selected. The last listed function has priority in case multiple functions are enabled on the same pin.

Table 3-2. Peripheral Functions

Function	Description
GPIO Controller Function multiplexing	GPIO and GPIO peripheral selection A to H
Nexus OCD AUX port connections	OCD trace system
aWire DATAOUT	aWire output in two-pin mode
JTAG port connections	JTAG debug port
Oscillators	OSC0, OSC32

3.2.3 JTAG Port Connections

If the JTAG is enabled, the JTAG will take control over a number of pins, irrespectively of the I/O Controller configuration.

Table 3-3. JTAG Pinout

48-pin	Pin Name	JTAG Pin
11	PA00	TCK
14	PA01	TMS
13	PA02	TDO
4	PA03	TDI

3.2.4 Nexus OCD AUX Port Connections

If the OCD trace system is enabled, the trace system will take control over a number of pins, irrespectively of the I/O Controller configuration. Two different OCD trace pin mappings are possible, depending on the configuration of the OCD AXS register. For details, see the AVR32 UC Technical Reference Manual.

Table 3-4. Nexus OCD AUX Port Connections

Pin	AXS=1	AXS=0
EVTI_N	PA05	PB08
MDO[5]	PA10	PB00
MDO[4]	PA18	PB04
MDO[3]	PA17	PB05

Table 3-4. Nexus OCD AUX Port Connections

Pin	AXS=1	AXS=0
MDO[2]	PA16	PB03
MDO[1]	PA15	PB02
MDO[0]	PA14	PB09
EVTO_N	PA04	PA04
MCKO	PA06	PB01
MSEO[1]	PA07	PB11
MSEO[0]	PA11	PB12

3.2.5 Oscillator Pinout

The oscillators are not mapped to the normal GPIO functions and their muxings are controlled by registers in the System Control Interface (SCIF). Please refer to the SCIF chapter for more information about this.

Table 3-5. Oscillator Pinout

48-pin	Pin	Oscillator Function
3	PA08	XIN0
46	PA10	XIN32
26	PA13	XIN32_2
2	PA09	XOUT0
47	PA12	XOUT32
25	PA20	XOUT32_2

3.2.6 Other Functions

The functions listed in [Table 3-6](#) are not mapped to the normal GPIO functions. The aWire DATA pin will only be active after the aWire is enabled. The aWire DATAOUT pin will only be active after the aWire is enabled and the 2_PIN_MODE command has been sent. The WAKE_N pin is always enabled. Please refer to [Section 6.1.4 on page 40](#) for constraints on the WAKE_N pin.

Table 3-6. Other Functions

48-pin	Pin	Function
27	PA11	WAKE_N
22	RESET_N	aWire DATA
11	PA00	aWire DATAOUT

3.3 Signal Descriptions

The following table gives details on signal name classified by peripheral.

Table 3-7. Signal Descriptions List

Signal Name	Function	Type	Active Level	Comments
Analog Comparator Interface - ACIFB				
ACAN3 - ACAN0	Negative inputs for comparators "A"	Analog		
ACAP3 - ACAP0	Positive inputs for comparators "A"	Analog		
ACBN3 - ACBN0	Negative inputs for comparators "B"	Analog		
ACBP3 - ACBP0	Positive inputs for comparators "B"	Analog		
ACREFN	Common negative reference	Analog		
ADC Interface - ADCIFB				
AD8 - AD0	Analog Signal	Analog		
ADP1 - ADP0	Drive Pin for resistive touch screen	Output		
PRND	Pseudorandom output signal	Output		
TRIGGER	External trigger	Input		
aWire - AW				
DATA	aWire data	I/O		
DATAOUT	aWire data output for 2-pin mode	I/O		
Capacitive Touch Module - CAT				
CSA16 - CSA0	Capacitive Sense A	I/O		
CSB16 - CSB0	Capacitive Sense B	I/O		
DIS	Discharge current control	Analog		
SMP	SMP signal	Output		
SYNC	Synchronize signal	Input		
VDIVEN	Voltage divider enable	Output		
External Interrupt Controller - EIC				
NMI	Non-Maskable Interrupt	Input		
EXTINT5 - EXTINT1	External interrupt	Input		
Glue Logic Controller - GLOC				
IN7 - IN0	Inputs to lookup tables	Input		
OUT1 - OUT0	Outputs from lookup tables	Output		
JTAG module - JTAG				
TCK	Test Clock	Input		
TDI	Test Data In	Input		
TDO	Test Data Out	Output		



Table 3-7. Signal Descriptions List

TMS	Test Mode Select	Input		
Power Manager - PM				
RESET_N	Reset	Input	Low	
Pulse Width Modulation Controller - PWMA				
PWMA35 - PWMA0	PWMA channel waveforms	Output		
PWMAOD35 - PWMAOD0	PWMA channel waveforms, open drain mode	Output		Not all channels support open drain mode
System Control Interface - SCIF				
GCLK4 - GCLK0	Generic Clock Output	Output		
RC32OUT	RC32K output at startup	Output		
XIN0	Crystal 0 Input	Analog/ Digital		
XIN32	Crystal 32 Input (primary location)	Analog/ Digital		
XIN32_2	Crystal 32 Input (secondary location)	Analog/ Digital		
XOUT0	Crystal 0 Output	Analog		
XOUT32	Crystal 32 Output (primary location)	Analog		
XOUT32_2	Crystal 32 Output (secondary location)	Analog		
Serial Peripheral Interface - SPI				
MISO	Master In Slave Out	I/O		
MOSI	Master Out Slave In	I/O		
NPCS3 - NPCS0	SPI Peripheral Chip Select	I/O	Low	
SCK	Clock	I/O		
Timer/Counter - TC0, TC1				
A0	Channel 0 Line A	I/O		
A1	Channel 1 Line A	I/O		
A2	Channel 2 Line A	I/O		
B0	Channel 0 Line B	I/O		
B1	Channel 1 Line B	I/O		
B2	Channel 2 Line B	I/O		
CLK0	Channel 0 External Clock Input	Input		
CLK1	Channel 1 External Clock Input	Input		
CLK2	Channel 2 External Clock Input	Input		
Two-wire Interface - TWIM0, TWIM1				
TWALM	SMBus SMBALERT	I/O	Low	
TWCK	Two-wire Serial Clock	I/O		
TWD	Two-wire Serial Data	I/O		

Table 3-7. Signal Descriptions List

Universal Synchronous/Asynchronous Receiver/Transmitter - USART0, USART1, USART2, USART3				
CLK	Clock	I/O		
CTS	Clear To Send	Input	Low	
RTS	Request To Send	Output	Low	
RXD	Receive Data	Input		
TXD	Transmit Data	Output		

Note: 1. ADCIFB: AD3 does not exist.

Table 3-8. Signal Description List, Continued

Signal Name	Function	Type	Active Level	Comments
Power				
VDDCORE	Core Power Supply / Voltage Regulator Output	Power Input/Output		1.62V to 1.98V
VDDIO	I/O Power Supply	Power Input		1.62V to 3.6V. VDDIO should always be equal to or lower than VDDIN.
VDDANA	Analog Power Supply	Power Input		1.62V to 1.98V
ADVREFP	Analog Reference Voltage	Power Input		1.62V to 1.98V
VDDIN	Voltage Regulator Input	Power Input		1.62V to 3.6V ⁽¹⁾
GNDANA	Analog Ground	Ground		
GND	Ground	Ground		
Auxiliary Port - AUX				
MCKO	Trace Data Output Clock	Output		
MDO5 - MDO0	Trace Data Output	Output		
MSEO1 - MSEO0	Trace Frame Control	Output		
EVTI_N	Event In	Input	Low	
EVTO_N	Event Out	Output	Low	
General Purpose I/O pin				
PA22 - PA00	Parallel I/O Controller I/O Port 0	I/O		
PB12 - PB00	Parallel I/O Controller I/O Port 1	I/O		

1. See [Section 6.1](#) on page 36

3.4 I/O Line Considerations

3.4.1 JTAG Pins

The JTAG is enabled if TCK is low while the RESET_N pin is released. The TCK, TMS, and TDI pins have pull-up resistors when JTAG is enabled. The TCK pin always has pull-up enabled during reset. The TDO pin is an output, driven at VDDIO, and has no pull-up resistor. The JTAG pins can be used as GPIO pins and multiplexed with peripherals when the JTAG is disabled. Please refer to [Section 3.2.3 on page 11](#) for the JTAG port connections.

3.4.2 PA00

Note that PA00 is multiplexed with TCK. PA00 GPIO function must only be used as output in the application.

3.4.3 RESET_N Pin

The RESET_N pin is a schmitt input and integrates a permanent pull-up resistor to VDDIN. As the product integrates a power-on reset detector, the RESET_N pin can be left unconnected in case no reset from the system needs to be applied to the product.

The RESET_N pin is also used for the aWire debug protocol. When the pin is used for debugging, it must not be driven by external circuitry.

3.4.4 TWI Pins PA21/PB04/PB05

When these pins are used for TWI, the pins are open-drain outputs with slew-rate limitation and inputs with spike filtering. When used as GPIO pins or used for other peripherals, the pins have the characteristics indicated in the Electrical Characteristics section. Selected pins are also SMBus compliant (refer to [Section 3.2 on page 9](#)). As required by the SMBus specification, these pins provide no leakage path to ground when the AT32UC3L is powered down. This allows other devices on the SMBus to continue communicating even though the AT32UC3L is not powered.

After reset a TWI function is selected on these pins instead of the GPIO. Please refer to the GPIO Module Configuration chapter for details.

3.4.5 TWI Pins PA05/PA07/PA17

When these pins are used for TWI, the pins are open-drain outputs with slew-rate limitation and inputs with spike filtering. When used as GPIO pins or used for other peripherals, the pins have the same characteristics as other GPIO pins.

After reset a TWI function is selected on these pins instead of the GPIO. Please refer to the GPIO Module Configuration chapter for details.

3.4.6 GPIO Pins

All the I/O lines integrate a pull-up resistor. Programming of this pull-up resistor is performed independently for each I/O line through the GPIO Controllers. After reset, I/O lines default as inputs with pull-up resistors disabled, except PA00. PA20 selects SCIF-RC32OUT (GPIO Function F) as default enabled after reset.

3.4.7 High-Drive Pins

The five pins PA02, PA06, PA08, PA09, and PB01 have high-drive output capabilities. Refer to [Section 7. on page 41](#) for electrical characteristics.

3.4.8 RC32OUT Pin

3.4.8.1 *Clock output at startup*

After power-up, the clock generated by the 32kHz RC oscillator (RC32K) will be output on PA20, even when the device is still reset by the Power-On Reset Circuitry. This clock can be used by the system to start other devices or to clock a switching regulator to rise the power supply voltage up to an acceptable value.

The clock will be available on PA20, but will be disabled if one of the following conditions are true:

- PA20 is configured to use a GPIO function other than F (SCIF-RC32OUT)
- PA20 is configured as a General Purpose Input/Output (GPIO)
- The bit FRC32 in the Power Manager PPCR register is written to zero (refer to the Power Manager chapter)

The maximum amplitude of the clock signal will be defined by VDDIN.

Once the RC32K output on PA20 is disabled it can never be enabled again.

3.4.8.2 *XOUT32_2 function*

PA20 selects RC32OUT as default enabled after reset. This function is not automatically disabled when the user enables the XOUT32_2 function on PA20. This disturbs the oscillator and may result in the wrong frequency. To avoid this, RC32OUT must be disabled when XOUT32_2 is enabled.

3.4.9 ADC Input Pins

These pins are regular I/O pins powered from the VDDIO. However, when these pins are used for ADC inputs, the voltage applied to the pin must not exceed 1.98V. Internal circuitry ensures that the pin cannot be used as an analog input pin when the I/O drives to VDD. When the pins are not used for ADC inputs, the pins may be driven to the full I/O voltage range.

4. Processor and Architecture

Rev: 2.1.0.0

This chapter gives an overview of the AVR32UC CPU. AVR32UC is an implementation of the AVR32 architecture. A summary of the programming model, instruction set, and MPU is presented. For further details, see the *AVR32 Architecture Manual* and the *AVR32UC Technical Reference Manual*.

4.1 Features

- **32-bit load/store AVR32A RISC architecture**
 - 15 general-purpose 32-bit registers
 - 32-bit Stack Pointer, Program Counter and Link Register reside in register file
 - Fully orthogonal instruction set
 - Privileged and unprivileged modes enabling efficient and secure operating systems
 - Innovative instruction set together with variable instruction length ensuring industry leading code density
 - DSP extension with saturating arithmetic, and a wide variety of multiply instructions
- **3-stage pipeline allowing one instruction per clock cycle for most instructions**
 - Byte, halfword, word, and double word memory access
 - Multiple interrupt priority levels
- **MPU allows for operating systems with memory protection**
- **Secure State for supporting FlashVault™ technology**

4.2 AVR32 Architecture

AVR32 is a new, high-performance 32-bit RISC microprocessor architecture, designed for cost-sensitive embedded applications, with particular emphasis on low power consumption and high code density. In addition, the instruction set architecture has been tuned to allow a variety of microarchitectures, enabling the AVR32 to be implemented as low-, mid-, or high-performance processors. AVR32 extends the AVR family into the world of 32- and 64-bit applications.

Through a quantitative approach, a large set of industry recognized benchmarks has been compiled and analyzed to achieve the best code density in its class. In addition to lowering the memory requirements, a compact code size also contributes to the core's low power characteristics. The processor supports byte and halfword data types without penalty in code size and performance.

Memory load and store operations are provided for byte, halfword, word, and double word data with automatic sign- or zero extension of halfword and byte data. The C-compiler is closely linked to the architecture and is able to exploit code optimization features, both for size and speed.

In order to reduce code size to a minimum, some instructions have multiple addressing modes. As an example, instructions with immediates often have a compact format with a smaller immediate, and an extended format with a larger immediate. In this way, the compiler is able to use the format giving the smallest code size.

Another feature of the instruction set is that frequently used instructions, like add, have a compact format with two operands as well as an extended format with three operands. The larger format increases performance, allowing an addition and a data move in the same instruction in a

single cycle. Load and store instructions have several different formats in order to reduce code size and speed up execution.

The register file is organized as sixteen 32-bit registers and includes the Program Counter, the Link Register, and the Stack Pointer. In addition, register R12 is designed to hold return values from function calls and is used implicitly by some instructions.

4.3 The AVR32UC CPU

The AVR32UC CPU targets low- and medium-performance applications, and provides an advanced On-Chip Debug (OCD) system, no caches, and a Memory Protection Unit (MPU). Java acceleration hardware is not implemented.

AVR32UC provides three memory interfaces, one High Speed Bus master for instruction fetch, one High Speed Bus master for data access, and one High Speed Bus slave interface allowing other bus masters to access data RAMs internal to the CPU. Keeping data RAMs internal to the CPU allows fast access to the RAMs, reduces latency, and guarantees deterministic timing. Also, power consumption is reduced by not needing a full High Speed Bus access for memory accesses. A dedicated data RAM interface is provided for communicating with the internal data RAMs.

A local bus interface is provided for connecting the CPU to device-specific high-speed systems, such as floating-point units and I/O controller ports. This local bus has to be enabled by writing a one to the LOCEN bit in the CPUCR system register. The local bus is able to transfer data between the CPU and the local bus slave in a single clock cycle. The local bus has a dedicated memory range allocated to it, and data transfers are performed using regular load and store instructions. Details on which devices that are mapped into the local bus space is given in the CPU Local Bus section in the Memories chapter.

[Figure 4-1 on page 20](#) displays the contents of AVR32UC.

Figure 4-1. Overview of the AVR32UC CPU

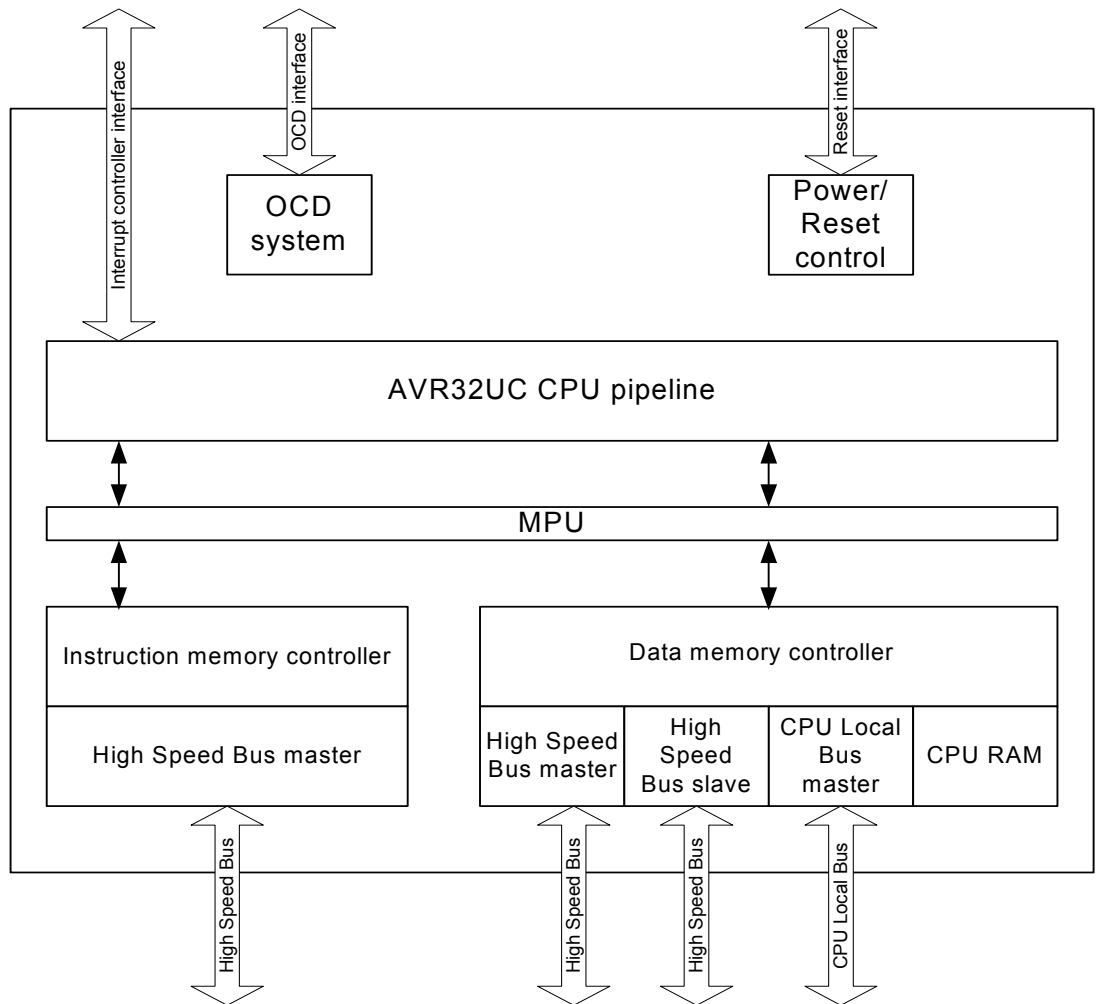

4.3.1 Pipeline Overview

AVR32UC has three pipeline stages, Instruction Fetch (IF), Instruction Decode (ID), and Instruction Execute (EX). The EX stage is split into three parallel subsections, one arithmetic/logic (ALU) section, one multiply (MUL) section, and one load/store (LS) section.

Instructions are issued and complete in order. Certain operations require several clock cycles to complete, and in this case, the instruction resides in the ID and EX stages for the required number of clock cycles. Since there is only three pipeline stages, no internal data forwarding is required, and no data dependencies can arise in the pipeline.

Figure 4-2 on page 21 shows an overview of the AVR32UC pipeline stages.

Figure 4-2. The AVR32UC Pipeline

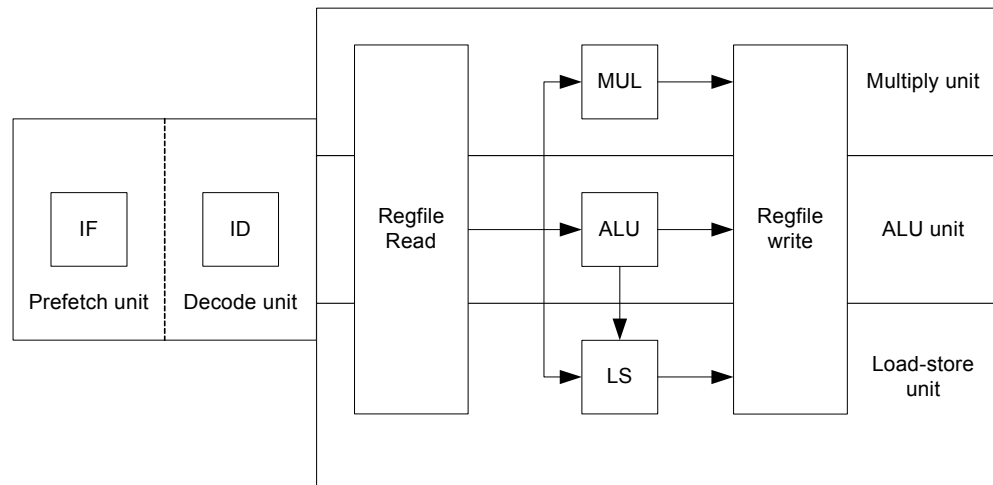

4.3.2 AVR32A Microarchitecture Compliance

AVR32UC implements an AVR32A microarchitecture. The AVR32A microarchitecture is targeted at cost-sensitive, lower-end applications like smaller microcontrollers. This microarchitecture does not provide dedicated hardware registers for shadowing of register file registers in interrupt contexts. Additionally, it does not provide hardware registers for the return address registers and return status registers. Instead, all this information is stored on the system stack. This saves chip area at the expense of slower interrupt handling.

4.3.2.1 Interrupt Handling

Upon interrupt initiation, registers R8-R12 are automatically pushed to the system stack. These registers are pushed regardless of the priority level of the pending interrupt. The return address and status register are also automatically pushed to stack. The interrupt handler can therefore use R8-R12 freely. Upon interrupt completion, the old R8-R12 registers and status register are restored, and execution continues at the return address stored popped from stack.

The stack is also used to store the status register and return address for exceptions and *scall*. Executing the *rete* or *rets* instruction at the completion of an exception or system call will pop this status register and continue execution at the popped return address.

4.3.2.2 Java Support

AVR32UC does not provide Java hardware acceleration.

4.3.2.3 Memory Protection

The MPU allows the user to check all memory accesses for privilege violations. If an access is attempted to an illegal memory address, the access is aborted and an exception is taken. The MPU in AVR32UC is specified in the AVR32UC Technical Reference manual.

4.3.2.4 Unaligned Reference Handling

AVR32UC does not support unaligned accesses, except for doubleword accesses. AVR32UC is able to perform word-aligned *st.d* and *ld.d*. Any other unaligned memory access will cause an

address exception. Doubleword-sized accesses with word-aligned pointers will automatically be performed as two word-sized accesses.

The following table shows the instructions with support for unaligned addresses. All other instructions require aligned addresses.

Table 4-1. Instructions with Unaligned Reference Support

Instruction	Supported Alignment
ld.d	Word
st.d	Word

4.3.2.5 *Unimplemented Instructions*

The following instructions are unimplemented in AVR32UC, and will cause an Unimplemented Instruction Exception if executed:

- All SIMD instructions
- All coprocessor instructions if no coprocessors are present
- retj, incjosp, popjc, pushjc
- tlbr, tlbs, tlbw
- cache

4.3.2.6 *CPU and Architecture Revision*

Three major revisions of the AVR32UC CPU currently exist. The device described in this datasheet uses CPU revision 3.

The Architecture Revision field in the CONFIG0 system register identifies which architecture revision is implemented in a specific device.

AVR32UC CPU revision 3 is fully backward-compatible with revisions 1 and 2, ie. code compiled for revision 1 or 2 is binary-compatible with revision 3 CPUs.

4.4 Programming Model

4.4.1 Register File Configuration

The AVR32UC register file is shown below.

Figure 4-3. The AVR32UC Register File

Application		Supervisor		INT0		INT1		INT2		INT3		Exception		NMI		Secure	
Bit 31	Bit 0	Bit 31	Bit 0	Bit 31	Bit 0	Bit 31	Bit 0	Bit 31	Bit 0	Bit 31	Bit 0	Bit 31	Bit 0	Bit 31	Bit 0	Bit 31	Bit 0
PC	PC	PC	PC	PC	PC	PC	PC	PC	PC	PC	PC	PC	PC	PC	PC	PC	PC
LR	LR	LR	LR	LR	LR	LR	LR	LR	LR	LR	LR	LR	LR	LR	LR	LR	LR
SP_APP	SP_SYS	SP_SYS	SP_SYS	SP_SYS	SP_SYS	SP_SYS	SP_SYS	SP_SYS	SP_SYS	SP_SYS	SP_SYS	SP_SYS	SP_SYS	SP_SYS	SP_SYS	SP_SEC	SP_SEC
R12	R12	R12	R12	R12	R12	R12	R12	R12	R12	R12	R12	R12	R12	R12	R12	R12	R12
R11	R11	R11	R11	R11	R11	R11	R11	R11	R11	R11	R11	R11	R11	R11	R11	R11	R11
R10	R10	R10	R10	R10	R10	R10	R10	R10	R10	R10	R10	R10	R10	R10	R10	R10	R10
R9	R9	R9	R9	R9	R9	R9	R9	R9	R9	R9	R9	R9	R9	R9	R9	R9	R9
R8	R8	R8	R8	R8	R8	R8	R8	R8	R8	R8	R8	R8	R8	R8	R8	R8	R8
R7	R7	R7	R7	R7	R7	R7	R7	R7	R7	R7	R7	R7	R7	R7	R7	R7	R7
R6	R6	R6	R6	R6	R6	R6	R6	R6	R6	R6	R6	R6	R6	R6	R6	R6	R6
R5	R5	R5	R5	R5	R5	R5	R5	R5	R5	R5	R5	R5	R5	R5	R5	R5	R5
R4	R4	R4	R4	R4	R4	R4	R4	R4	R4	R4	R4	R4	R4	R4	R4	R4	R4
R3	R3	R3	R3	R3	R3	R3	R3	R3	R3	R3	R3	R3	R3	R3	R3	R3	R3
R2	R2	R2	R2	R2	R2	R2	R2	R2	R2	R2	R2	R2	R2	R2	R2	R2	R2
R1	R1	R1	R1	R1	R1	R1	R1	R1	R1	R1	R1	R1	R1	R1	R1	R1	R1
R0	R0	R0	R0	R0	R0	R0	R0	R0	R0	R0	R0	R0	R0	R0	R0	R0	R0
SR	SR	SR	SR	SR	SR	SR	SR	SR	SR	SR	SR	SR	SR	SR	SR	SR	SR

SS_STATUS
SS_ADRF
SS_ADRR
SS_ADR0
SS_ADR1
SS_SP_SYS
SS_SP_APP
SS_RAR
SS_RSR

4.4.2 Status Register Configuration

The Status Register (SR) is split into two halfwords, one upper and one lower, see [Figure 4-4](#) and [Figure 4-5](#). The lower word contains the C, Z, N, V, and Q condition code flags and the R, T, and L bits, while the upper halfword contains information about the mode and state the processor executes in. Refer to the *AVR32 Architecture Manual* for details.

Figure 4-4. The Status Register High Halfword

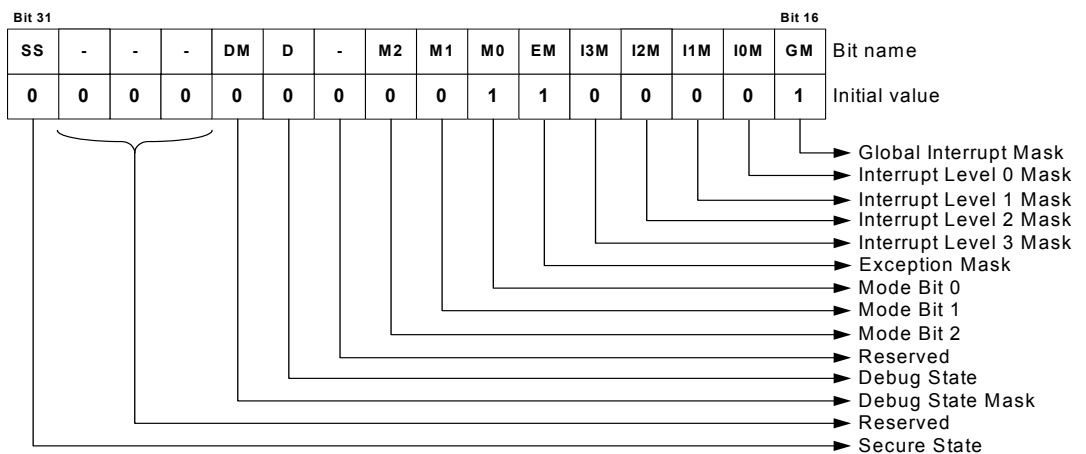
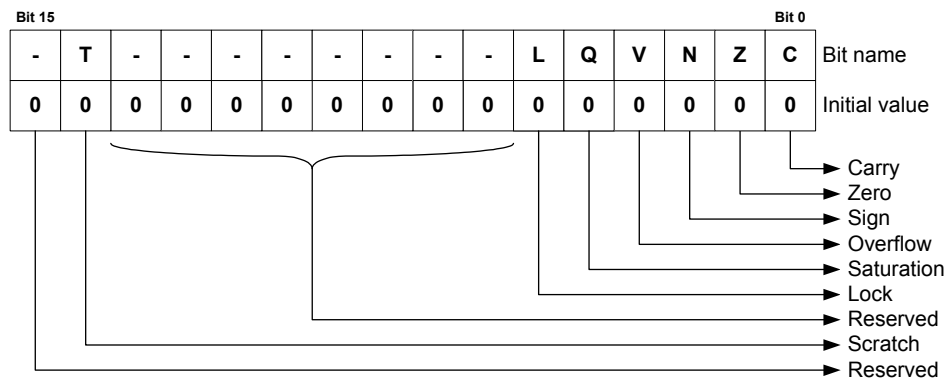

Figure 4-5. The Status Register Low Halfword



4.4.3 Processor States

4.4.3.1 Normal RISC State

The AVR32 processor supports several different execution contexts as shown in [Table 4-2](#).

Table 4-2. Overview of Execution Modes, their Priorities and Privilege Levels.

Priority	Mode	Security	Description
1	Non Maskable Interrupt	Privileged	Non Maskable high priority interrupt mode
2	Exception	Privileged	Execute exceptions
3	Interrupt 3	Privileged	General purpose interrupt mode
4	Interrupt 2	Privileged	General purpose interrupt mode
5	Interrupt 1	Privileged	General purpose interrupt mode
6	Interrupt 0	Privileged	General purpose interrupt mode
N/A	Supervisor	Privileged	Runs supervisor calls
N/A	Application	Unprivileged	Normal program execution mode

Mode changes can be made under software control, or can be caused by external interrupts or exception processing. A mode can be interrupted by a higher priority mode, but never by one with lower priority. Nested exceptions can be supported with a minimal software overhead.

When running an operating system on the AVR32, user processes will typically execute in the application mode. The programs executed in this mode are restricted from executing certain instructions. Furthermore, most system registers together with the upper halfword of the status register cannot be accessed. Protected memory areas are also not available. All other operating modes are privileged and are collectively called System Modes. They have full access to all privileged and unprivileged resources. After a reset, the processor will be in supervisor mode.

4.4.3.2 Debug State

The AVR32 can be set in a debug state, which allows implementation of software monitor routines that can read out and alter system information for use during application development. This implies that all system and application registers, including the status registers and program counters, are accessible in debug state. The privileged instructions are also available.

All interrupt levels are by default disabled when debug state is entered, but they can individually be switched on by the monitor routine by clearing the respective mask bit in the status register.

Debug state can be entered as described in the *AVR32UC Technical Reference Manual*.

Debug state is exited by the *retd* instruction.

4.4.3.3 Secure State

The AVR32 can be set in a secure state, that allows a part of the code to execute in a state with higher security levels. The rest of the code can not access resources reserved for this secure code. Secure State is used to implement FlashVault technology. Refer to the *AVR32UC Technical Reference Manual* for details.

4.4.4 System Registers

The system registers are placed outside of the virtual memory space, and are only accessible using the privileged *mfsr* and *mtsr* instructions. The table below lists the system registers specified in the AVR32 architecture, some of which are unused in AVR32UC. The programmer is responsible for maintaining correct sequencing of any instructions following a *mtsr* instruction. For detail on the system registers, refer to the *AVR32UC Technical Reference Manual*.

Table 4-3. System Registers

Reg #	Address	Name	Function
0	0	SR	Status Register
1	4	EVBA	Exception Vector Base Address
2	8	ACBA	Application Call Base Address
3	12	CPUCR	CPU Control Register
4	16	ECR	Exception Cause Register
5	20	RSR_SUP	Unused in AVR32UC
6	24	RSR_INT0	Unused in AVR32UC
7	28	RSR_INT1	Unused in AVR32UC
8	32	RSR_INT2	Unused in AVR32UC
9	36	RSR_INT3	Unused in AVR32UC
10	40	RSR_EX	Unused in AVR32UC
11	44	RSR_NMI	Unused in AVR32UC
12	48	RSR_DBG	Return Status Register for Debug mode
13	52	RAR_SUP	Unused in AVR32UC
14	56	RAR_INT0	Unused in AVR32UC
15	60	RAR_INT1	Unused in AVR32UC
16	64	RAR_INT2	Unused in AVR32UC
17	68	RAR_INT3	Unused in AVR32UC
18	72	RAR_EX	Unused in AVR32UC
19	76	RAR_NMI	Unused in AVR32UC
20	80	RAR_DBG	Return Address Register for Debug mode
21	84	JECR	Unused in AVR32UC
22	88	JOSP	Unused in AVR32UC
23	92	JAVA_LV0	Unused in AVR32UC

Table 4-3. System Registers (Continued)

Reg #	Address	Name	Function
24	96	JAVA_LV1	Unused in AVR32UC
25	100	JAVA_LV2	Unused in AVR32UC
26	104	JAVA_LV3	Unused in AVR32UC
27	108	JAVA_LV4	Unused in AVR32UC
28	112	JAVA_LV5	Unused in AVR32UC
29	116	JAVA_LV6	Unused in AVR32UC
30	120	JAVA_LV7	Unused in AVR32UC
31	124	JTBA	Unused in AVR32UC
32	128	JBCR	Unused in AVR32UC
33-63	132-252	Reserved	Reserved for future use
64	256	CONFIG0	Configuration register 0
65	260	CONFIG1	Configuration register 1
66	264	COUNT	Cycle Counter register
67	268	COMPARE	Compare register
68	272	TLBEHI	Unused in AVR32UC
69	276	TLBELO	Unused in AVR32UC
70	280	PTBR	Unused in AVR32UC
71	284	TLBEAR	Unused in AVR32UC
72	288	MMUCR	Unused in AVR32UC
73	292	TLBARLO	Unused in AVR32UC
74	296	TLBARHI	Unused in AVR32UC
75	300	PCCNT	Unused in AVR32UC
76	304	PCNT0	Unused in AVR32UC
77	308	PCNT1	Unused in AVR32UC
78	312	PCCR	Unused in AVR32UC
79	316	BEAR	Bus Error Address Register
80	320	MPUAR0	MPU Address Register region 0
81	324	MPUAR1	MPU Address Register region 1
82	328	MPUAR2	MPU Address Register region 2
83	332	MPUAR3	MPU Address Register region 3
84	336	MPUAR4	MPU Address Register region 4
85	340	MPUAR5	MPU Address Register region 5
86	344	MPUAR6	MPU Address Register region 6
87	348	MPUAR7	MPU Address Register region 7
88	352	MPUPSR0	MPU Privilege Select Register region 0
89	356	MPUPSR1	MPU Privilege Select Register region 1

Table 4-3. System Registers (Continued)

Reg #	Address	Name	Function
90	360	MPUPSR2	MPU Privilege Select Register region 2
91	364	MPUPSR3	MPU Privilege Select Register region 3
92	368	MPUPSR4	MPU Privilege Select Register region 4
93	372	MPUPSR5	MPU Privilege Select Register region 5
94	376	MPUPSR6	MPU Privilege Select Register region 6
95	380	MPUPSR7	MPU Privilege Select Register region 7
96	384	MPUCRA	Unused in this version of AVR32UC
97	388	MPUCRB	Unused in this version of AVR32UC
98	392	MPUBRA	Unused in this version of AVR32UC
99	396	MPUBRB	Unused in this version of AVR32UC
100	400	MPUAPRA	MPU Access Permission Register A
101	404	MPUAPRB	MPU Access Permission Register B
102	408	MPUCR	MPU Control Register
103	412	SS_STATUS	Secure State Status Register
104	416	SS_ADRF	Secure State Address Flash Register
105	420	SS_ADRR	Secure State Address RAM Register
106	424	SS_ADR0	Secure State Address 0 Register
107	428	SS_ADR1	Secure State Address 1 Register
108	432	SS_SP_SYS	Secure State Stack Pointer System Register
109	436	SS_SP_APP	Secure State Stack Pointer Application Register
110	440	SS_RAR	Secure State Return Address Register
111	444	SS_RSR	Secure State Return Status Register
112-191	448-764	Reserved	Reserved for future use
192-255	768-1020	IMPL	IMPLEMENTATION DEFINED

4.5 Exceptions and Interrupts

In the AVR32 architecture, events are used as a common term for exceptions and interrupts. AVR32UC incorporates a powerful event handling scheme. The different event sources, like Illegal Op-code and interrupt requests, have different priority levels, ensuring a well-defined behavior when multiple events are received simultaneously. Additionally, pending events of a higher priority class may preempt handling of ongoing events of a lower priority class.

When an event occurs, the execution of the instruction stream is halted, and execution is passed to an event handler at an address specified in [Table 4-4 on page 31](#). Most of the handlers are placed sequentially in the code space starting at the address specified by EVBA, with four bytes between each handler. This gives ample space for a jump instruction to be placed there, jumping to the event routine itself. A few critical handlers have larger spacing between them, allowing the entire event routine to be placed directly at the address specified by the EVBA-relative offset generated by hardware. All interrupt sources have autovectored interrupt service routine (ISR) addresses. This allows the interrupt controller to directly specify the ISR address as an address

relative to EVBA. The autovector offset has 14 address bits, giving an offset of maximum 16384 bytes. The target address of the event handler is calculated as (EVBA | event_handler_offset), not (EVBA + event_handler_offset), so EVBA and exception code segments must be set up appropriately. The same mechanisms are used to service all different types of events, including interrupt requests, yielding a uniform event handling scheme.

An interrupt controller does the priority handling of the interrupts and provides the autovector offset to the CPU.

4.5.1 System Stack Issues

Event handling in AVR32UC uses the system stack pointed to by the system stack pointer, SP_SYS, for pushing and popping R8-R12, LR, status register, and return address. Since event code may be timing-critical, SP_SYS should point to memory addresses in the IRAM section, since the timing of accesses to this memory section is both fast and deterministic.

The user must also make sure that the system stack is large enough so that any event is able to push the required registers to stack. If the system stack is full, and an event occurs, the system will enter an UNDEFINED state.

4.5.2 Exceptions and Interrupt Requests

When an event other than *scall* or debug request is received by the core, the following actions are performed atomically:

1. The pending event will not be accepted if it is masked. The I3M, I2M, I1M, I0M, EM, and GM bits in the Status Register are used to mask different events. Not all events can be masked. A few critical events (NMI, Unrecoverable Exception, TLB Multiple Hit, and Bus Error) can not be masked. When an event is accepted, hardware automatically sets the mask bits corresponding to all sources with equal or lower priority. This inhibits acceptance of other events of the same or lower priority, except for the critical events listed above. Software may choose to clear some or all of these bits after saving the necessary state if other priority schemes are desired. It is the event source's responsibility to ensure that their events are left pending until accepted by the CPU.
2. When a request is accepted, the Status Register and Program Counter of the current context is stored to the system stack. If the event is an INT0, INT1, INT2, or INT3, registers R8-R12 and LR are also automatically stored to stack. Storing the Status Register ensures that the core is returned to the previous execution mode when the current event handling is completed. When exceptions occur, both the EM and GM bits are set, and the application may manually enable nested exceptions if desired by clearing the appropriate bit. Each exception handler has a dedicated handler address, and this address uniquely identifies the exception source.
3. The Mode bits are set to reflect the priority of the accepted event, and the correct register file bank is selected. The address of the event handler, as shown in [Table 4-4 on page 31](#), is loaded into the Program Counter.

The execution of the event handler routine then continues from the effective address calculated.

The *rete* instruction signals the end of the event. When encountered, the Return Status Register and Return Address Register are popped from the system stack and restored to the Status Register and Program Counter. If the *rete* instruction returns from INT0, INT1, INT2, or INT3, registers R8-R12 and LR are also popped from the system stack. The restored Status Register contains information allowing the core to resume operation in the previous execution mode. This concludes the event handling.

4.5.3 Supervisor Calls

The AVR32 instruction set provides a supervisor mode call instruction. The *scall* instruction is designed so that privileged routines can be called from any context. This facilitates sharing of code between different execution modes. The *scall* mechanism is designed so that a minimal execution cycle overhead is experienced when performing supervisor routine calls from time-critical event handlers.

The *scall* instruction behaves differently depending on which mode it is called from. The behaviour is detailed in the instruction set reference. In order to allow the *scall* routine to return to the correct context, a return from supervisor call instruction, *rets*, is implemented. In the AVR32UC CPU, *scall* and *rets* uses the system stack to store the return address and the status register.

4.5.4 Debug Requests

The AVR32 architecture defines a dedicated Debug mode. When a debug request is received by the core, Debug mode is entered. Entry into Debug mode can be masked by the DM bit in the status register. Upon entry into Debug mode, hardware sets the SR.D bit and jumps to the Debug Exception handler. By default, Debug mode executes in the exception context, but with dedicated Return Address Register and Return Status Register. These dedicated registers remove the need for storing this data to the system stack, thereby improving debuggability. The Mode bits in the Status Register can freely be manipulated in Debug mode, to observe registers in all contexts, while retaining full privileges.

Debug mode is exited by executing the *retd* instruction. This returns to the previous context.

4.5.5 Entry Points for Events

Several different event handler entry points exist. In AVR32UC, the reset address is 0x80000000. This places the reset address in the boot flash memory area.

TLB miss exceptions and *scall* have a dedicated space relative to EVBA where their event handler can be placed. This speeds up execution by removing the need for a jump instruction placed at the program address jumped to by the event hardware. All other exceptions have a dedicated event routine entry point located relative to EVBA. The handler routine address identifies the exception source directly.

AVR32UC uses the ITLB and DTLB protection exceptions to signal a MPU protection violation. ITLB and DTLB miss exceptions are used to signal that an access address did not map to any of the entries in the MPU. TLB multiple hit exception indicates that an access address did map to multiple TLB entries, signalling an error.

All interrupt requests have entry points located at an offset relative to EVBA. This autovector offset is specified by an interrupt controller. The programmer must make sure that none of the autovector offsets interfere with the placement of other code. The autovector offset has 14 address bits, giving an offset of maximum 16384 bytes.

Special considerations should be made when loading EVBA with a pointer. Due to security considerations, the event handlers should be located in non-writeable flash memory, or optionally in a privileged memory protection region if an MPU is present.

If several events occur on the same instruction, they are handled in a prioritized way. The priority ordering is presented in [Table 4-4 on page 31](#). If events occur on several instructions at different locations in the pipeline, the events on the oldest instruction are always handled before any events on any younger instruction, even if the younger instruction has events of higher priority

than the oldest instruction. An instruction B is younger than an instruction A if it was sent down the pipeline later than A.

The addresses and priority of simultaneous events are shown in [Table 4-4 on page 31](#). Some of the exceptions are unused in AVR32UC since it has no MMU, coprocessor interface, or floating-point unit.

Table 4-4. Priority and Handler Addresses for Events

Priority	Handler Address	Name	Event source	Stored Return Address
1	0x80000000	Reset	External input	Undefined
2	Provided by OCD system	OCD Stop CPU	OCD system	First non-completed instruction
3	EVBA+0x00	Unrecoverable exception	Internal	PC of offending instruction
4	EVBA+0x04	TLB multiple hit	MPU	PC of offending instruction
5	EVBA+0x08	Bus error data fetch	Data bus	First non-completed instruction
6	EVBA+0x0C	Bus error instruction fetch	Data bus	First non-completed instruction
7	EVBA+0x10	NMI	External input	First non-completed instruction
8	Autovectored	Interrupt 3 request	External input	First non-completed instruction
9	Autovectored	Interrupt 2 request	External input	First non-completed instruction
10	Autovectored	Interrupt 1 request	External input	First non-completed instruction
11	Autovectored	Interrupt 0 request	External input	First non-completed instruction
12	EVBA+0x14	Instruction Address	CPU	PC of offending instruction
13	EVBA+0x50	ITLB Miss	MPU	PC of offending instruction
14	EVBA+0x18	ITLB Protection	MPU	PC of offending instruction
15	EVBA+0x1C	Breakpoint	OCD system	First non-completed instruction
16	EVBA+0x20	Illegal Opcode	Instruction	PC of offending instruction
17	EVBA+0x24	Unimplemented instruction	Instruction	PC of offending instruction
18	EVBA+0x28	Privilege violation	Instruction	PC of offending instruction
19	EVBA+0x2C	Floating-point	UNUSED	
20	EVBA+0x30	Coprocessor absent	Instruction	PC of offending instruction
21	EVBA+0x100	Supervisor call	Instruction	PC(Supervisor Call) +2
22	EVBA+0x34	Data Address (Read)	CPU	PC of offending instruction
23	EVBA+0x38	Data Address (Write)	CPU	PC of offending instruction
24	EVBA+0x60	DTLB Miss (Read)	MPU	PC of offending instruction
25	EVBA+0x70	DTLB Miss (Write)	MPU	PC of offending instruction
26	EVBA+0x3C	DTLB Protection (Read)	MPU	PC of offending instruction
27	EVBA+0x40	DTLB Protection (Write)	MPU	PC of offending instruction
28	EVBA+0x44	DTLB Modified	UNUSED	

5. Memories

5.1 Embedded Memories

- Internal High-Speed Flash
 - 64 Kbytes (AT32UC3L064)
 - 32 Kbytes (AT32UC3L032)
 - 16 Kbytes (AT32UC3L016)
 - 0 Wait State Access at up to 25 MHz in Worst Case Conditions
 - 1 Wait State Access at up to 50 MHz in Worst Case Conditions
 - Pipelined Flash Architecture, allowing burst reads from sequential Flash locations, hiding penalty of 1 wait state access
 - Pipelined Flash Architecture typically reduces the cycle penalty of 1 wait state operation to only 8% compared to 0 wait state operation
 - 100 000 Write Cycles, 15-year Data Retention Capability
 - Sector Lock Capabilities, Bootloader Protection, Security Bit
 - 32 Fuses, Erased During Chip Erase
 - User Page For Data To Be Preserved During Chip Erase
- Internal High-Speed SRAM, Single-cycle access at full speed
 - 16 Kbytes (AT32UC3L064, AT32UC3L032)
 - 8 Kbytes (AT32UC3L016)

5.2 Physical Memory Map

The system bus is implemented as a bus matrix. All system bus addresses are fixed, and they are never remapped in any way, not even in boot. Note that AVR32 UC CPU uses unsegmented translation, as described in the AVR32 Architecture Manual. The 32-bit physical address space is mapped as follows:

Table 5-1. AT32UC3L Physical Memory Map

Device	Start Address	Size		
		AT32UC3L064	AT32UC3L032	AT32UC3L016
Embedded SRAM	0x00000000	16Kbytes	16Kbytes	8Kbytes
Embedded Flash	0x80000000	64Kbytes	32Kbytes	16Kbytes
HSB-PB Bridge B	0xFFFFE0000	64Kbytes	64Kbytes	64Kbytes
HSB-PB Bridge A	0xFFFFF0000	64Kbytes	64Kbytes	64Kbytes

Table 5-2. Flash Memory Parameters

Part Number	Flash Size (<i>FLASH_PW</i>)	Number of pages (<i>FLASH_P</i>)	Page size (<i>FLASH_W</i>)
AT32UC3L064	64Kbytes	256	256 bytes
AT32UC3L032	32Kbytes	128	256 bytes
AT32UC3L016	16Kbytes	64	256 bytes

5.3 Peripheral Address Map

Table 5-3. Peripheral Address Mapping

Address		Peripheral Name
0xFFFE0000	FLASHCDW	Flash Controller - FLASHCDW
0xFFFE0400	HMATRIX	HSB Matrix - HMATRIX
0xFFFE0800	SAU	Secure Access Unit - SAU
0xFFFF0000	PDCA	Peripheral DMA Controller - PDCA
0xFFFF1000	INTC	Interrupt controller - INTC
0xFFFF1400	PM	Power Manager - PM
0xFFFF1800	SCIF	System Control Interface - SCIF
0xFFFF1C00	AST	Asynchronous Timer - AST
0xFFFF2000	WDT	Watchdog Timer - WDT
0xFFFF2400	EIC	External Interrupt Controller - EIC
0xFFFF2800	FREQM	Frequency Meter - FREQM
0xFFFF2C00	GPIO	General Purpose Input/Output Controller - GPIO
0xFFFF3000	USART0	Universal Synchronous/Asynchronous Receiver/Transmitter - USART0
0xFFFF3400	USART1	Universal Synchronous/Asynchronous Receiver/Transmitter - USART1
0xFFFF3800	USART2	Universal Synchronous/Asynchronous Receiver/Transmitter - USART2
0xFFFF3C00	USART3	Universal Synchronous/Asynchronous Receiver/Transmitter - USART3
0xFFFF4000	SPI	Serial Peripheral Interface - SPI
0xFFFF4400	TWIM0	Two-wire Master Interface - TWIM0

Table 5-3. Peripheral Address Mapping

0xFFFF4800	TWIM1	Two-wire Master Interface - TWIM1
0xFFFF4C00	TWIS0	Two-wire Slave Interface - TWIS0
0xFFFF5000	TWIS1	Two-wire Slave Interface - TWIS1
0xFFFF5400	PWMA	Pulse Width Modulation Controller - PWMA
0xFFFF5800	TC0	Timer/Counter - TC0
0xFFFF5C00	TC1	Timer/Counter - TC1
0xFFFF6000	ADCIFB	ADC Interface - ADCIFB
0xFFFF6400	ACIFB	Analog Comparator Interface - ACIFB
0xFFFF6800	CAT	Capacitive Touch Module - CAT
0xFFFF6C00	GLOC	Glue Logic Controller - GLOC
0xFFFF7000	AW	aWire - AW

5.4 CPU Local Bus Mapping

Some of the registers in the GPIO module are mapped onto the CPU local bus, in addition to being mapped on the Peripheral Bus. These registers can therefore be reached both by accesses on the Peripheral Bus, and by accesses on the local bus.

Mapping these registers on the local bus allows cycle-deterministic toggling of GPIO pins since the CPU and GPIO are the only modules connected to this bus. Also, since the local bus runs at CPU speed, one write or read operation can be performed per clock cycle to the local bus-mapped GPIO registers.

The following GPIO registers are mapped on the local bus:

Table 5-4. Local Bus Mapped GPIO Registers

Port	Register	Mode	Local Bus Address	Access
0	Output Driver Enable Register (ODER)	WRITE	0x40000040	Write-only
		SET	0x40000044	Write-only
		CLEAR	0x40000048	Write-only
		TOGGLE	0x4000004C	Write-only
	Output Value Register (OVR)	WRITE	0x40000050	Write-only
		SET	0x40000054	Write-only
		CLEAR	0x40000058	Write-only
		TOGGLE	0x4000005C	Write-only
	Pin Value Register (PVR)	-	0x40000060	Read-only
	1	Output Driver Enable Register (ODER)	WRITE	0x40000240
SET			0x40000244	Write-only
CLEAR			0x40000248	Write-only
TOGGLE			0x4000024C	Write-only
Output Value Register (OVR)		WRITE	0x40000250	Write-only
		SET	0x40000254	Write-only
		CLEAR	0x40000258	Write-only
		TOGGLE	0x4000025C	Write-only
Pin Value Register (PVR)		-	0x40000260	Read-only

6. Supply and Startup Considerations

6.1 Supply Considerations

6.1.1 Power Supplies

The AT32UC3L has several types of power supply pins:

- VDDIO: Powers I/O lines. Voltage is 1.8 to 3.3V nominal.
- VDDIN: Powers I/O lines and the internal regulator. Voltage is 1.8 to 3.3V nominal.
- VDDANA: Powers the ADC. Voltage is 1.8V nominal.
- VDDCORE: Powers the core, memories, and peripherals. Voltage is 1.8V nominal.

The ground pins GND are common to VDDCORE, VDDIO, and VDDIN. The ground pin for VDDANA is GNDANA.

When VDDCORE is not connected to VDDIN, the VDDIN voltage must be higher than 1.98V.

Refer to [Section 7. on page 41](#) for power consumption on the various supply pins.

For decoupling recommendations for the different power supplies, please refer to the schematic checklist.

6.1.2 Voltage Regulator

The AT32UC3L embeds a voltage regulator that converts from 3.3V nominal to 1.8V with a load of up to 60mA. The regulator supplies the output voltage on VDDCORE. The regulator may only be used to drive internal circuitry in the device. VDDCORE should be externally connected to the 1.8V domains. See [Section 6.1.3](#) for regulator connection figures.

Adequate output supply decoupling is mandatory for VDDCORE to reduce ripple and avoid oscillations. The best way to achieve this is to use two capacitors in parallel between VDDCORE and GND as close to the chip as possible. Please refer to [Section 7.9.1 on page 55](#) for decoupling capacitors values and regulator characteristics.

Figure 6-1. Supply Decoupling

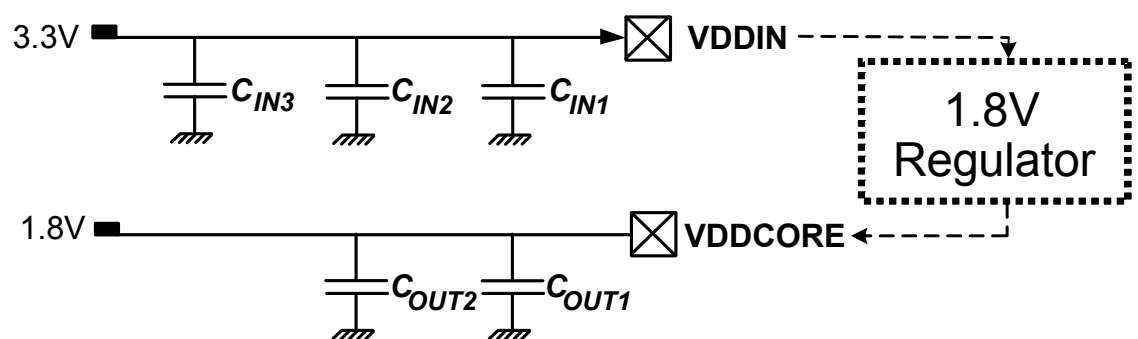

6.1.3 Regulator Connection

The AT32UC3L supports three power supply configurations:

- 3.3V single supply mode
- 1.8V single supply mode
- 3.3V supply mode, with 1.8V regulated I/O lines

6.1.3.1 3.3V Single Supply Mode

In 3.3V single supply mode the internal regulator is connected to the 3.3V source (VDDIN pin) and its output feeds VDDCORE. Figure 6-2 shows the power schematics to be used for 3.3V single supply mode. All I/O lines will be powered by the same power (VDDIN=VDDIO).

Figure 6-2. 3.3V Single Supply Mode

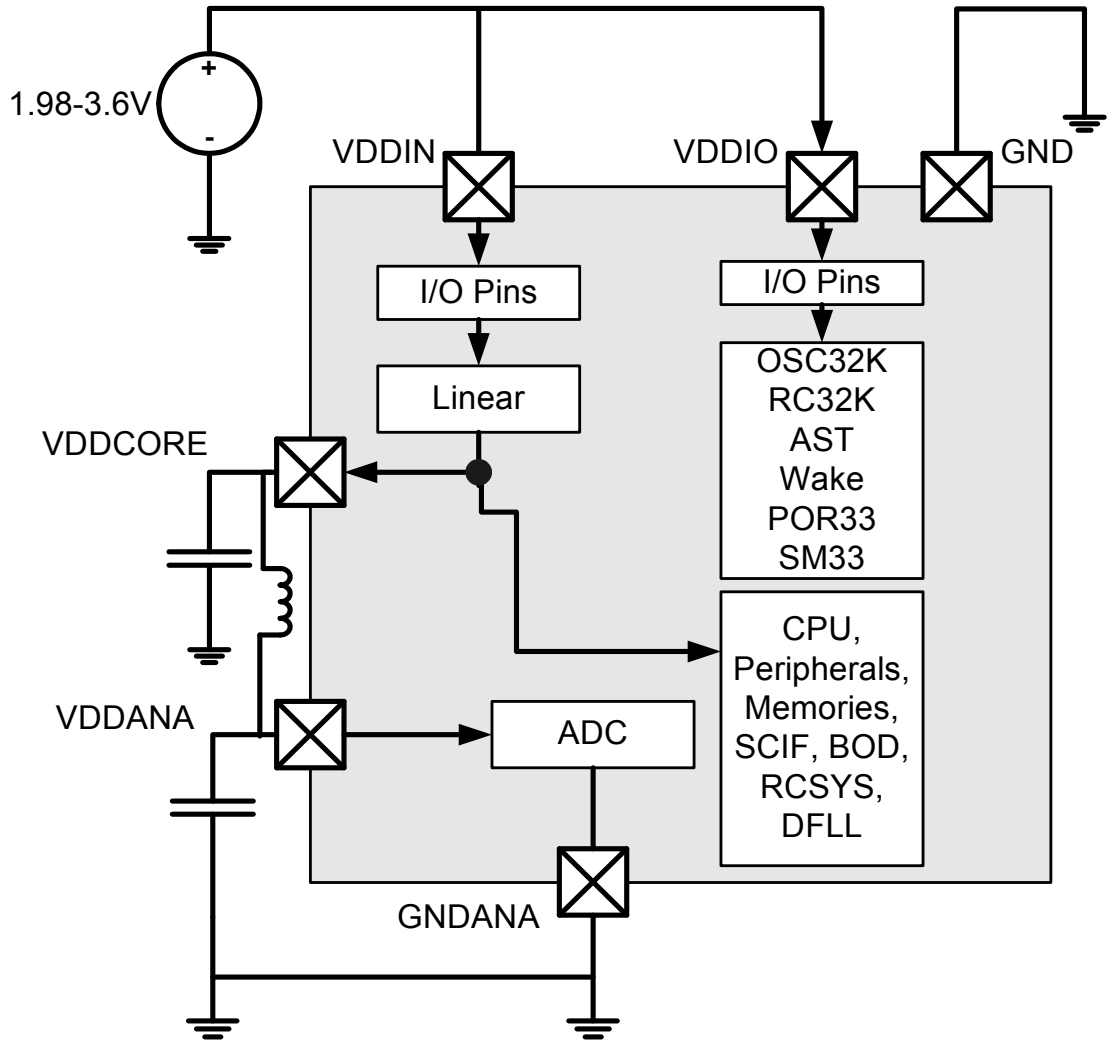

6.1.3.2 1.8V Single Supply Mode

In 1.8V single supply mode the internal regulator is not used, and VDDIO and VDDCORE are powered by a single 1.8V supply as shown in Figure 6-3. All I/O lines will be powered by the same power (VDDIN = VDDIO = VDDCORE).

Figure 6-3. 1.8V Single Supply Mode.

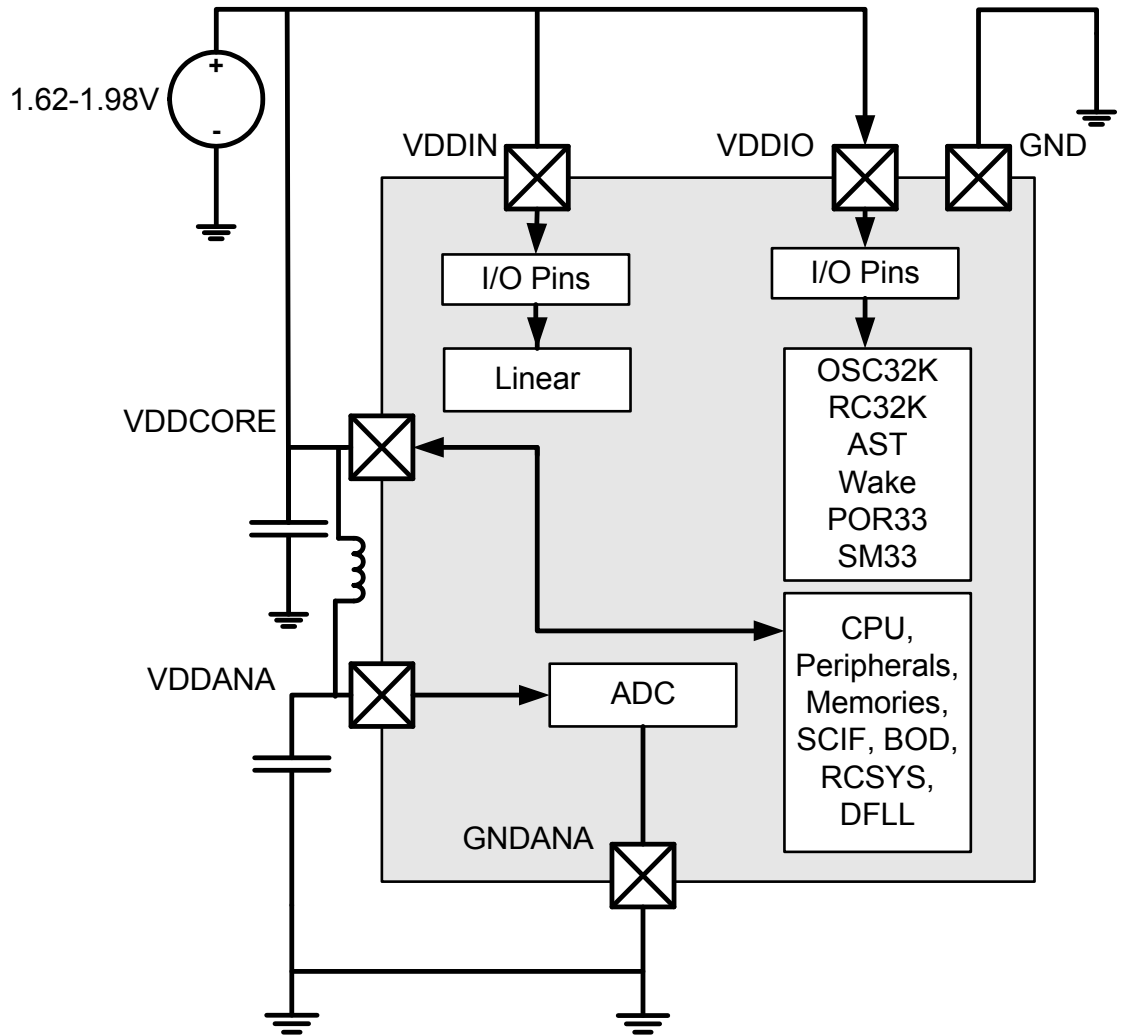

6.1.3.3 3.3V Supply Mode with 1.8V Regulated I/O Lines

In this mode, the internal regulator is connected to the 3.3V source and its output is connected to both VDDCORE and VDDIO as shown in Figure 6-4. This configuration is required in order to use Shutdown mode.

Figure 6-4. 3.3V Supply Mode with 1.8V Regulated I/O Lines

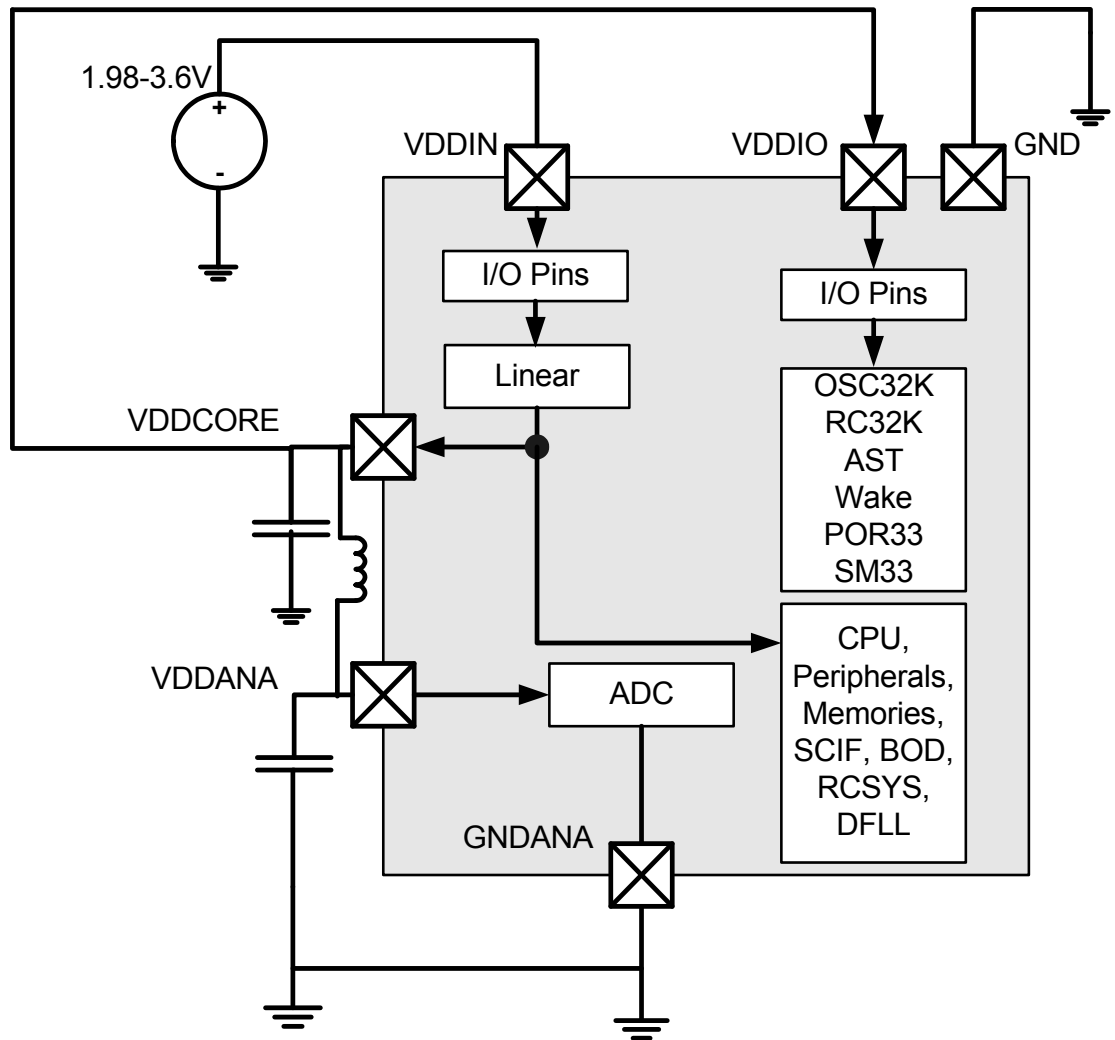

In this mode, some I/O lines are powered by VDDIN while other I/O lines are powered by VDDIO. Refer to Section 3.2 on page 9 for description of power supply for each I/O line.

Refer to the Power Manager chapter for a description of what parts of the system are powered in Shutdown mode.

Important note: As the regulator has a maximum output current of 60mA, this mode can only be used in applications where the maximum I/O current is known and compatible with the core and peripheral power consumption. Typically, great care must be used to ensure that only a few I/O lines are toggling at the same time and drive very small loads.

6.1.4 Power-up Sequence

6.1.4.1 Maximum Rise Rate

To avoid risk of latch-up, the rise rate of the power supplies must not exceed the values described in [Table 7-3 on page 42](#).

Recommended order for power supplies is also described in this chapter.

6.1.4.2 Minimum Rise Rate

The integrated Power-on Reset (POR33) circuitry monitoring the VDDIN powering supply requires a minimum rise rate for the VDDIN power supply.

See [Table 7-3 on page 42](#) for the minimum rise rate value.

If the application can not ensure that the minimum rise rate condition for the VDDIN power supply is met, one of the following configurations can be used:

- A logic “0” value is applied during power-up on pin PA11 until VDDIN rises above 1.2V.
- A logic “0” value is applied during power-up on pin RESET_N until VDDIN rises above 1.2V.

6.2 Startup Considerations

This chapter summarizes the boot sequence of the AT32UC3L. The behavior after power-up is controlled by the Power Manager. For specific details, refer to the Power Manager chapter.

6.2.1 Starting of Clocks

After power-up, the device will be held in a reset state by the Power-on Reset (POR18 and POR33) circuitry for a short time to allow the power to stabilize throughout the device. After reset, the device will use the System RC Oscillator (RCSYS) as clock source. Please refer to [Table 7-17 on page 54](#) for the frequency for this oscillator.

On system start-up, the DFLL is disabled. All clocks to all modules are running. No clocks have a divided frequency; all parts of the system receive a clock with the same frequency as the System RC Oscillator.

When powering up the device, there may be a delay before the voltage has stabilized, depending on the rise time of the supply used. The CPU can start executing code as soon as the supply is above the POR18 and POR33 thresholds, and before the supply is stable. Before switching to a high-speed clock source, the user should use the BOD to make sure the VDDCORE is above the minimum level (1.62V).

6.2.2 Fetching of Initial Instructions

After reset has been released, the AVR32 UC CPU starts fetching instructions from the reset address, which is 0x80000000. This address points to the first address in the internal Flash.

The code read from the internal Flash is free to configure the system to use, for example, the DFLL, to divide the frequency of the clock routed to some of the peripherals, and to gate the clocks to unused peripherals.

7. Electrical Characteristics

7.1 Disclaimer

All values in this chapter are preliminary and subject to change without further notice.

7.2 Absolute Maximum Ratings*

Table 7-1. Absolute Maximum Ratings

Operating temperature.....	-40°C to +85°C
Storage temperature.....	-60°C to +150°C
Voltage on input pins (except for 5V pins) with respect to ground	-0.3V to $V_{VDD}^{(2)}$ +0.3V
Voltage on 5V tolerant ⁽¹⁾ pins with respect to ground	-0.3V to 5.5V
Total DC output current on all I/O pins - VDDIO	120mA
Total DC output current on all I/O pins - VDDIN	36mA
Maximum operating voltage VDDCORE	1.98V
Maximum operating voltage VDDIO, VDDIN	3.6V

*NOTICE: Stresses beyond those listed under “Absolute Maximum Ratings” may cause permanent damage to the device. This is a stress rating only and functional operation of the device at these or other conditions beyond those indicated in the operational sections of this specification is not implied. Exposure to absolute maximum rating conditions for extended periods may affect device reliability.

- Notes: 1. 5V tolerant pins, see [Section 3.2 “Peripheral Multiplexing on I/O lines” on page 9](#)
 2. V_{VDD} corresponds to either V_{VDDIN} or V_{VDDIO} , depending on the supply for the pin. Refer to [Section 3.2 on page 9](#) for details.

7.3 Supply Characteristics

The following characteristics are applicable to the operating temperature range: $T_A = -40^\circ\text{C}$ to 85°C , unless otherwise specified and are valid for a junction temperature up to $T_J = 100^\circ\text{C}$. Please refer to [Section 6. “Supply and Startup Considerations” on page 36](#).

Table 7-2. Supply Characteristics

Symbol	Parameter	Voltage		
		Min	Max	Unit
V_{VDDIO}	DC supply peripheral I/Os	1.62	3.6	V
V_{VDDIN}	DC supply peripheral I/Os, 1.8V single supply mode	1.62	1.98	V
	DC supply peripheral I/Os and internal regulator, 3.3V supply mode	1.98	3.6	V
$V_{VDDCORE}$	DC supply core	1.62	1.98	V
V_{VDDANA}	Analog supply voltage	1.62	1.98	V

Table 7-3. Supply Rise Rates and Order⁽¹⁾

Symbol	Parameter	Rise Rate			
		Min	Max	Unit	Comment
V _{VDDIO}	DC supply peripheral I/Os	0	2.5	V/μs	
V _{VDDIN}	DC supply peripheral I/Os and internal regulator	0.002	2.5	V/μs	Slower rise time requires external power-on reset circuit.
V _{VDDCORE}	DC supply core	0	2.5	V/μs	Rise before or at the same time as VDDIO
V _{VDDANA}	Analog supply voltage	0	2.5	V/μs	Rise together with VDDCORE

Note: 1. These values are based on simulation and characterization of other AVR microcontrollers manufactured in the same process technology. These values are not covered by test limits in production.

7.4 Maximum Clock Frequencies

These parameters are given in the following conditions:

- V_{VDDCORE} = 1.62V to 1.98V
- Temperature = -40°C to 85°C

Table 7-4. Clock Frequencies

Symbol	Parameter	Conditions	Min	Max	Units
f _{CPU}	CPU clock frequency			50	MHz
f _{PBA}	PBA clock frequency			50	MHz
f _{PBB}	PBB clock frequency			50	MHz
f _{GCLK0}	GCLK0 clock frequency	DFLLIF main reference, GCLK0 pin		150	MHz
f _{GCLK1}	GCLK1 clock frequency	DFLLIF dithering and ssg reference, GCLK1 pin		150	MHz
f _{GCLK2}	GCLK2 clock frequency	AST, GCLK2 pin		80	MHz
f _{GCLK3}	GCLK3 clock frequency	PWMA, GCLK3 pin		110	MHz
f _{GCLK4}	GCLK4 clock frequency	CAT, ACIFB, GCLK4 pin		110	MHz
f _{GCLK5}	GCLK5 clock frequency	GLOC		80	MHz

7.5 Power Consumption

The values in [Table 7-5](#) are measured values of power consumption under the following conditions, except where noted:

- Operating conditions internal core supply ([Figure 7-1](#)) - this is the default configuration
 - V_{VDDIN} = 3.0V
 - V_{VDDCORE} = 1.62V, supplied by the internal regulator

- Corresponds to the 3.3V supply mode with 1.8V regulated I/O lines, please refer to the Supply and Startup Considerations section for more details
 - Equivalent to the 3.3V single supply mode
 - Consumption in 1.8V single supply mode can be estimated by subtracting the regulator static current
- Operating conditions external core supply (Figure 7-2) - used only when noted
 - $V_{VDDIN} = V_{VDDCORE} = 1.8V$
 - Corresponds to the 1.8V single supply mode, please refer to the Supply and Startup Considerations section for more details
- $T_A = 25^{\circ}C$
- Oscillators
 - OSC0 (crystal oscillator) stopped
 - OSC32K (32KHz crystal oscillator) running with external 32KHz crystal
 - DFLL running at 50MHz with OSC32K as reference
- Clocks
 - DFLL used as main clock source
 - CPU, HSB, and PBB clocks undivided
 - PBA clock divided by 4
 - The following peripheral clocks running
 - PM, SCIF, AST, FLASHCDW, PBA bridge
 - All other peripheral clocks stopped
- I/Os are inactive with internal pull-up
- Flash enabled in high speed mode
- POR33 disabled

Table 7-5. Power Consumption for Different Operating Modes

Mode	Conditions	Measured on	Consumption Typ	Unit
Active ⁽¹⁾	-CPU running a recursive Fibonacci algorithm	Amp0	260	$\mu\text{A}/\text{MHz}$
	-CPU running a division algorithm		165	
Idle ⁽¹⁾	92			
Frozen ⁽¹⁾	58			
Standby ⁽¹⁾	47			
Stop	37			
DeepStop	23		μA	
Static	-OSC32K and AST stopped -Internal core supply			10
	-OSC32K running -AST running at 1 KHz -External core supply (Figure 7-2)			5.3
	-OSC32K and AST stopped -External core supply (Figure 7-2)			4.7
Shutdown	-OSC32K running -AST running at 1 KHz	600	nA	
	-AST and OSC32K stopped	9		

Note: 1. These numbers are valid for the measured condition only and must not be extrapolated to other frequencies.

Figure 7-1. Measurement Schematic, Internal Core Supply

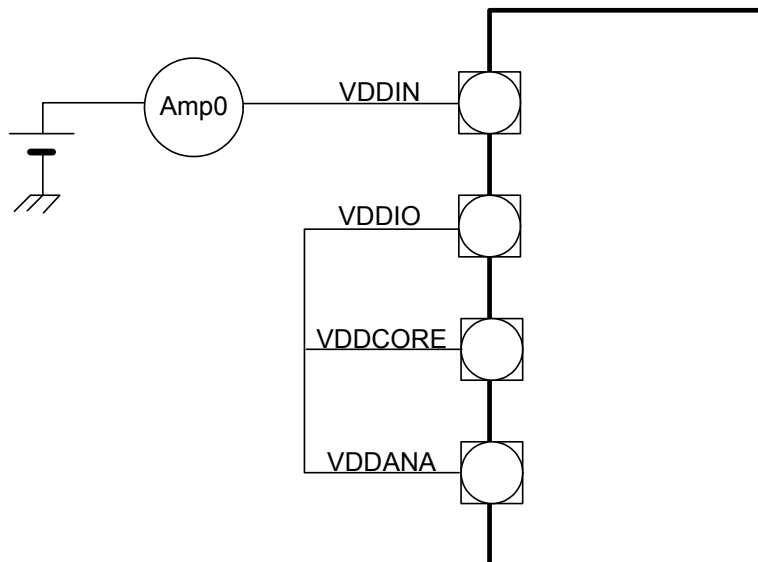
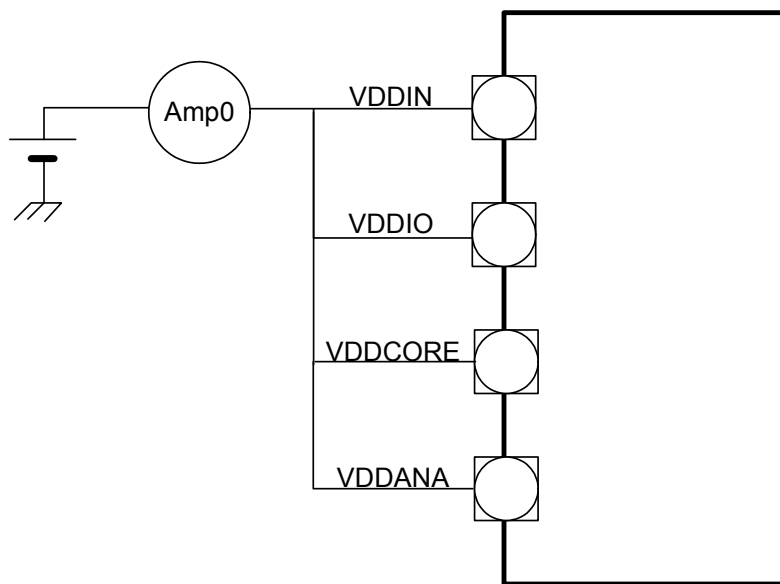

Figure 7-2. Measurement Schematic, External Core Supply



7.5.1 Peripheral Power Consumption

The values in [Table 7-6](#) are measured values of power consumption under the following conditions.

- Operating conditions internal core supply ([Figure 7-1](#))
 - $V_{VDDIN} = 3.0V$
 - $V_{VDDCORE} = 1.62V$, supplied by the internal regulator
 - Corresponds to the 3.3V supply mode with 1.8V regulated I/O lines, please refer to the Supply and Startup Considerations section for more details
- $T_A = 25^{\circ}C$
- Oscillators
 - OSC0 (crystal oscillator) stopped
 - OSC32K (32KHz crystal oscillator) running with external 32KHz crystal
 - DFLL running at 50MHz with OSC32K as reference
- Clocks
 - DFLL used as main clock source
 - CPU, HSB, and PB clocks undivided
- I/Os are inactive with internal pull-up
- Flash enabled in high speed mode
- POR33 disabled

Consumption active is the added current consumption when the module clock is turned on and the module is doing a typical set of operations

Table 7-6. Typical Current Consumption by Peripheral⁽²⁾

Peripheral	Typ Consumption Active	Unit
ACIFB	14.0	μA/MHz
ADCIFB ⁽¹⁾	14.9	
AST	5.6	
AW USART	6.8	
CAT	12.4	
EIC	1.3	
FREQM	3.2	
GLOC	0.4	
GPIO	15.9	
PWMA	2.5	
SPI	7.6	
TC	7.2	
TWIM	5.1	
TWIS	3.2	
USART	12.3	
WDT	2.3	

- Notes:
1. Includes the current consumption on VDDANA and ADVREFP.
 2. These numbers are valid for the measured condition only and must not be extrapolated to other frequencies.

7.6 I/O Pin Characteristics

Table 7-7. Normal I/O Pin Characteristics⁽¹⁾

Symbol	Parameter	Condition	Min	Typ	Max	Units
R _{PULLUP}	Pull-up resistance		75	100	145	kOhm
V _{IL}	Input low-level voltage	V _{VDD} = 3.0V	-0.3		0.3*V _{VDD}	V
		V _{VDD} = 1.62V	-0.3		0.3*V _{VDD}	
V _{IH}	Input high-level voltage	V _{VDD} = 3.6V	0.7*V _{VDD}		V _{VDD} + 0.3	V
		V _{VDD} = 1.98V	0.7*V _{VDD}		V _{VDD} + 0.3	
V _{OL}	Output low-level voltage	V _{VDD} = 3.0V, I _{OL} = 3mA			0.4	V
		V _{VDD} = 1.62V, I _{OL} = 2mA			0.4	
V _{OH}	Output high-level voltage	V _{VDD} = 3.0V, I _{OH} = 3mA	V _{VDD} - 0.4			V
		V _{VDD} = 1.62V, I _{OH} = 2mA	V _{VDD} - 0.4			
f _{MAX}	Output frequency ⁽²⁾	V _{VDD} = 3.0V, load = 10pF			45	MHz
		V _{VDD} = 3.0V, load = 30pF			23	
t _{RISE}	Rise time ⁽²⁾	V _{VDD} = 3.0V, load = 10pF			4.7	ns
		V _{VDD} = 3.0V, load = 30pF			11.5	
t _{FALL}	Fall time ⁽²⁾	V _{VDD} = 3.0V, load = 10pF			4.8	
		V _{VDD} = 3.0V, load = 30pF			12	
I _{LEAK}	Input leakage current	Pull-up resistors disabled			1	μA
C _{IN}	Input capacitance, all normal I/O pins except PA05, PA07, PA17, PA20, PA21, PB04, PB05	TQFP48 package		1.4		pF
		QFN48 package		1.1		
C _{IN}	Input capacitance, PA20	TQFP48 package		2.7		
		QFN48 package		2.4		
C _{IN}	Input capacitance, PA05, PA07, PA17, PA21, PB04, PB05	TQFP48 package		3.8		
		QFN48 package		3.5		

- Notes: 1. V_{VDD} corresponds to either V_{VDDIN} or V_{VDDIO}, depending on the supply for the pin. Refer to [Section 3.2 on page 9](#) for details.
 2. These values are based on simulation and characterization of other AVR microcontrollers manufactured in the same process technology. These values are not covered by test limits in production.

Table 7-8. High-drive I/O Pin Characteristics⁽¹⁾

Symbol	Parameter	Condition	Min	Typ	Max	Units
R _{PULLUP}	Pull-up resistance	PA06	30	50	110	kOhm
		PA02, PB01, RESET	75	100	145	
		PA08, PA09	10	20	45	
V _{IL}	Input low-level voltage	V _{VDD} = 3.0V	-0.3		0.3*V _{VDD}	V
		V _{VDD} = 1.62V	-0.3		0.3*V _{VDD}	

Table 7-8. High-drive I/O Pin Characteristics⁽¹⁾

Symbol	Parameter	Condition	Min	Typ	Max	Units
V _{IH}	Input high-level voltage	V _{VDD} = 3.6V	0.7*V _{VDD}		V _{VDD} + 0.3	V
		V _{VDD} = 1.98V	0.7*V _{VDD}		V _{VDD} + 0.3	
V _{OL}	Output low-level voltage	V _{VDD} = 3.0V, I _{OL} = 6mA			0.4	V
		V _{VDD} = 1.62V, I _{OL} = 4mA			0.4	
V _{OH}	Output high-level voltage	V _{VDD} = 3.0V, I _{OH} = 6mA	V _{VDD} -0.4			V
		V _{VDD} = 1.62V, I _{OH} = 4mA	V _{VDD} -0.4			
f _{MAX}	Output frequency, all High-drive I/O pins, except PA08 and PA09 ⁽²⁾	V _{VDD} = 3.0V, load = 10pF			45	MHz
		V _{VDD} = 3.0V, load = 30pF			23	
t _{RISE}	Rise time, all High-drive I/O pins, except PA08 and PA09 ⁽²⁾	V _{VDD} = 3.0V, load = 10pF			4.7	ns
		V _{VDD} = 3.0V, load = 30pF			11.5	
t _{FALL}	Fall time, all High-drive I/O pins, except PA08 and PA09 ⁽²⁾	V _{VDD} = 3.0V, load = 10pF			4.8	
		V _{VDD} = 3.0V, load = 30pF			12	
f _{MAX}	Output frequency, PA08 and PA09 ⁽²⁾	V _{VDD} = 3.0V, load = 10pF			52	MHz
		V _{VDD} = 3.0V, load = 30pF			39	
t _{RISE}	Rise time, PA08 and PA09 ⁽²⁾	V _{VDD} = 3.0V, load = 10pF			2.9	ns
		V _{VDD} = 3.0V, load = 30pF			4.9	
t _{FALL}	Fall time, PA08 and PA09 ⁽²⁾	V _{VDD} = 3.0V, load = 10pF			2.5	
		V _{VDD} = 3.0V, load = 30pF			4.6	
I _{LEAK}	Input leakage current	Pull-up resistors disabled			1	μA
C _{IN}	Input capacitance, all High-drive I/O pins, except PA08 and PA09	TQFP48 package		2,2		pF
		QFN48 package		2.0		
C _{IN}	Input capacitance, PA08 and PA09	TQFP48 package		7.0		
		QFN48 package		6.7		

Notes: 1. V_{VDD} corresponds to either V_{VDDIN} or V_{VDDIO}, depending on the supply for the pin. Refer to [Section 3.2 on page 9](#) for details.
 2. These values are based on simulation and characterization of other AVR microcontrollers manufactured in the same process technology. These values are not covered by test limits in production.

Table 7-9. High-drive I/O, 5V Tolerant, Pin Characteristics⁽¹⁾

Symbol	Parameter	Condition	Min	Typ	Max	Units
R _{PULLUP}	Pull-up resistance		30	50	110	kOhm
V _{IL}	Input low-level voltage	V _{VDD} = 3.0V	-0.3		0.3*V _{VDD}	V
		V _{VDD} = 1.62V	-0.3		0.3*V _{VDD}	
V _{IH}	Input high-level voltage	V _{VDD} = 3.6V	0.7*V _{VDD}		5.5	V
		V _{VDD} = 1.98V	0.7*V _{VDD}		5.5	
V _{OL}	Output low-level voltage	V _{VDD} = 3.0V, I _{OL} = 6mA			0.4	V
		V _{VDD} = 1.62V, I _{OL} = 4mA			0.4	

Table 7-9. High-drive I/O, 5V Tolerant, Pin Characteristics⁽¹⁾

Symbol	Parameter	Condition	Min	Typ	Max	Units
V _{OH}	Output high-level voltage	V _{VDD} = 3.0V, I _{OH} = 6mA	V _{VDD} -0.4			V
		V _{VDD} = 1.62V, I _{OH} = 4mA	V _{VDD} -0.4			
f _{MAX}	Output frequency ⁽²⁾	V _{VDD} = 3.0V, load = 10pF			87	MHz
		V _{VDD} = 3.0V, load = 30pF			58	
t _{RISE}	Rise time ⁽²⁾	V _{VDD} = 3.0V, load = 10pF			2.3	ns
		V _{VDD} = 3.0V, load = 30pF			4.3	
t _{FALL}	Fall time ⁽²⁾	V _{VDD} = 3.0V, load = 10pF			1.9	
		V _{VDD} = 3.0V, load = 30pF			3.7	
I _{LEAK}	Input leakage current	5.5V, pull-up resistors disabled			10	μA
C _{IN}	Input capacitance	TQFP48 package		4.5		pF
		QFN48 package		4.2		

Notes: 1. V_{VDD} corresponds to either V_{VDDIN} or V_{VDDIO}, depending on the supply for the pin. Refer to [Section 3.2 on page 9](#) for details.
 2. These values are based on simulation and characterization of other AVR microcontrollers manufactured in the same process technology. These values are not covered by test limits in production.

Table 7-10. TWI Pin Characteristics⁽¹⁾

Symbol	Parameter	Condition	Min	Typ	Max	Units
R _{PULLUP}	Pull-up resistance		25	35	60	kOhm
V _{IL}	Input low-level voltage	V _{VDD} = 3.0V	-0.3		0.3*V _{VDD}	V
		V _{VDD} = 1.62V	-0.3		0.3*V _{VDD}	
V _{IH}	Input high-level voltage	V _{VDD} = 3.6V	0.7*V _{VDD}		V _{VDD} + 0.3	V
		V _{VDD} = 1.98V	0.7*V _{VDD}		V _{VDD} + 0.3	
	Input high-level voltage, 5V tolerant SMBUS compliant pins	V _{VDD} = 3.6V	0.7*V _{VDD}		5.5	V
		V _{VDD} = 1.98V	0.7*V _{VDD}		5.5	
V _{OL}	Output low-level voltage	I _{OL} = 3mA			0.4	V
I _{LEAK}	Input leakage current	Pull-up resistors disabled			1	μA
I _{IL}	Input low leakage				1	
I _{IH}	Input high leakage				1	
C _{IN}	Input capacitance	TQFP48 package		3.8		pF
		QFN48 package		3.5		
	Fall time	C _{bus} = 400pF, V _{VDD} > 2.0V		250		ns
		C _{bus} = 400pF, V _{VDD} > 1.62V		470		
f _{MAX}	Max frequency	C _{bus} = 400pF, V _{VDD} > 2.0V	400			kHz

Note: 1. V_{VDD} corresponds to either V_{VDDIN} or V_{VDDIO}, depending on the supply for the pin. Refer to [Section 3.2 on page 9](#) for details.

7.7 Oscillator Characteristics

7.7.1 Oscillator 0 (OSC0) Characteristics

7.7.1.1 Digital Clock Characteristics

The following table describes the characteristics for the oscillator when a digital clock is applied on XIN.

Table 7-11. Digital Clock Characteristics

Symbol	Parameter	Conditions	Min	Typ	Max	Units
f_{CPXIN}	XIN clock frequency				50	MHz
t_{CPXIN}	XIN clock duty cycle		40		60	%
$t_{STARTUP}$	Startup time			0		cycles
C_{IN}	XIN input capacitance	TQFP48 package		7.0		pF
		QFN48 package		6.7		

7.7.1.2 Crystal Oscillator Characteristics

The following table describes the characteristics for the oscillator when a crystal is connected between XIN and XOUT as shown in [Figure 7-3](#). The user must choose a crystal oscillator where the crystal load capacitance C_L is within the range given in the table. The exact value of C_L can be found in the crystal datasheet. The capacitance of the external capacitors (C_{LEXT}) can then be computed as follows:

$$C_{LEXT} = 2(C_L - C_i) - C_{PCB}$$

where C_{PCB} is the capacitance of the PCB and C_i is the internal equivalent load capacitance.

Table 7-12. Crystal Oscillator Characteristics

Symbol	Parameter	Conditions	Min	Typ	Max	Unit
f_{OUT}	Crystal oscillator frequency		0.45	10	16	MHz
C_L	Crystal load capacitance		6		18	pF
C_i	Internal equivalent load capacitance			2		
$t_{STARTUP}$	Startup time	SCIF.OSCCTRL.GAIN = 2 ⁽¹⁾		30 000 ⁽²⁾		cycles
I_{OSC}	Current consumption	Active mode, $f = 0.45\text{MHz}$, SCIF.OSCCTRL.GAIN = 0		30		μA
		Active mode, $f = 10\text{MHz}$, SCIF.OSCCTRL.GAIN = 2		170		

- Notes:
1. Please refer to the SCIF chapter for details.
 2. Nominal crystal cycles.
 3. These values are based on simulation and characterization of other AVR microcontrollers manufactured in the same process technology. These values are not covered by test limits in production.

Figure 7-3. Oscillator Connection

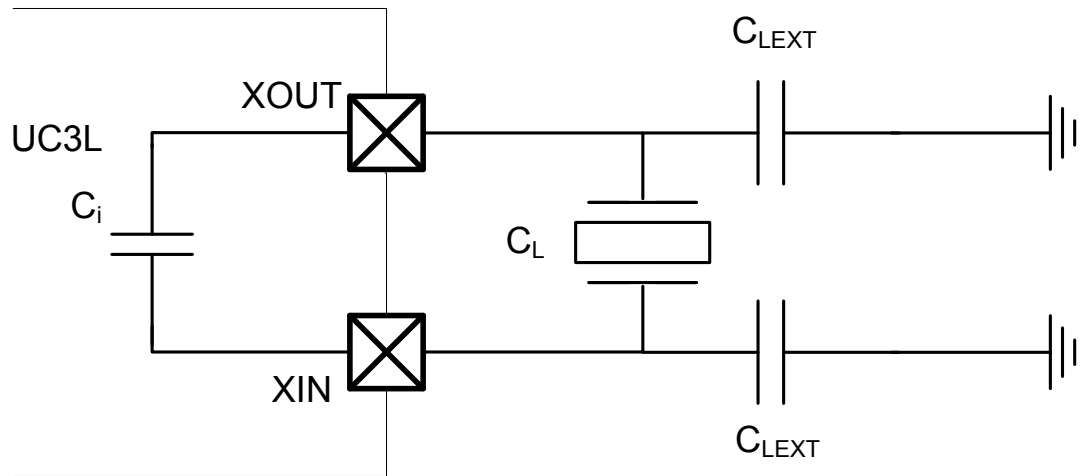

7.7.2 32KHz Crystal Oscillator (OSC32K) Characteristics

Figure 7-3 and the equation above also applies to the 32KHz oscillator connection. The user must choose a crystal oscillator where the crystal load capacitance C_L is within the range given in the table. The exact value of C_L can then be found in the crystal datasheet.

Table 7-13. 32 KHz Crystal Oscillator Characteristics

Symbol	Parameter	Conditions	Min	Typ	Max	Unit
f_{OUT}	Crystal oscillator frequency			32 768		Hz
$t_{STARTUP}$	Startup time	$R_S = 60k\Omega, C_L = 9pF$		30 000 ⁽¹⁾		cycles
C_L	Crystal load capacitance ⁽²⁾		6		12.5	pF
C_i	Internal equivalent load capacitance			2		
I_{OSC32}	Current consumption			0.9		μA
R_S	Equivalent series resistance ⁽²⁾	32 768Hz	35		85	k Ω

- Notes:
1. Nominal crystal cycles.
 2. These values are based on simulation and characterization of other AVR microcontrollers manufactured in the same process technology. These values are not covered by test limits in production.

7.7.3 Digital Frequency Locked Loop (DFLL) Characteristics

Table 7-14. Digital Frequency Locked Loop Characteristics

Symbol	Parameter	Conditions	Min	Typ	Max	Unit
f_{OUT}	Output frequency ⁽²⁾		40		150	MHz
f_{REF}	Reference frequency ⁽²⁾		8		150	kHz
	FINE resolution	FINE > 100, all COARSE values		0.25		%
	Frequency drift over voltage and temperature			See Figure 7-4		
	Accuracy ⁽²⁾	Fine lock, $f_{REF} = 32\text{kHz}$, SSG disabled		0.1	0.5	%
		Accurate lock, $f_{REF} = 32\text{kHz}$, dither clk RCSYS/2, SSG disabled		0.06	0.5	
		Fine lock, $f_{REF} = 8\text{-}150\text{kHz}$, SSG disabled		0.2	1	
		Accurate lock, $f_{REF} = 8\text{-}150\text{kHz}$, dither clk RCSYS/2, SSG disabled		0.1	1	
I_{DFLL}	Power consumption			22		$\mu\text{A}/\text{MHz}$
$t_{STARTUP}$	Startup time ⁽²⁾	Within 90% of final values			100	μs
t_{LOCK}	Lock time	$f_{REF} = 32\text{kHz}$, fine lock, SSG disabled		600		
		$f_{REF} = 32\text{kHz}$, accurate lock, dithering clock = RCSYS/2, SSG disabled		1100		

- Notes:
1. Spread Spectrum Generator (SSG) is disabled by writing a zero to the EN bit in the SCIF.DFLL0SSG register.
 2. These values are based on simulation and characterization of other AVR microcontrollers manufactured in the same process technology. These values are not covered by test limits in production.

Figure 7-4. DFLL Open Loop Frequency Variation⁽¹⁾

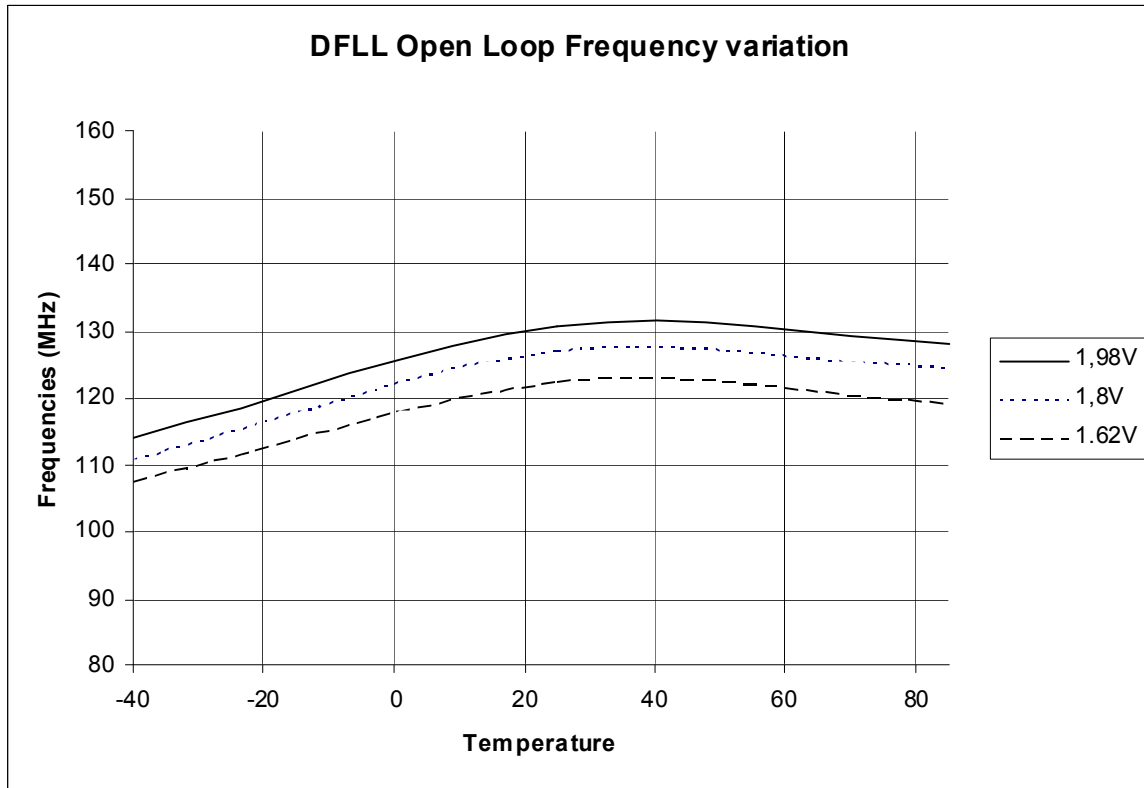

Note: 1. The plot shows a typical behaviour for coarse = 99 and fine = 255 in open loop mode.

7.7.4 120MHz RC Oscillator (RC120M) Characteristics

Table 7-15. Internal 120MHz RC Oscillator Characteristics

Symbol	Parameter	Conditions	Min	Typ	Max	Unit
f_{OUT}	Output frequency ⁽¹⁾		88	120	152	MHz
I_{RC120M}	Current consumption			1.85		mA
$t_{STARTUP}$	Startup time	$V_{VDDCORE} = 1.8V$		3		μs

Note: 1. These values are based on simulation and characterization of other AVR microcontrollers manufactured in the same process technology. These values are not covered by test limits in production.

7.7.5 32kHz RC Oscillator (RC32K) Characteristics

Table 7-16. 32kHz RC Oscillator Characteristics

Symbol	Parameter	Conditions	Min	Typ	Max	Unit
f_{OUT}	Output frequency ⁽¹⁾		20	32	44	kHz
I_{RC32K}	Current consumption			0.6		μ A
$t_{STARTUP}$	Startup time			100		μ s

Note: 1. These values are based on simulation and characterization of other AVR microcontrollers manufactured in the same process technology. These values are not covered by test limits in production.

7.7.6 System RC Oscillator (RCSYS) Characteristics

Table 7-17. System RC Oscillator Characteristics

Symbol	Parameter	Conditions	Min	Typ	Max	Unit
f_{OUT}	Output frequency	Calibrated at 85°C	111.6	115	118.4	kHz

7.8 Flash Characteristics

Table 7-18 gives the device maximum operating frequency depending on the number of flash wait states and the flash read mode. The FSW bit in the FLASHCDW FSR register controls the number of wait states used when accessing the flash memory.

Table 7-18. Maximum Operating Frequency

Flash Wait States	Read Mode	Maximum Operating Frequency
1	High speed read mode	50MHz
0		25MHz
1	Normal read mode	30MHz
0		15MHz

Table 7-19. Flash Characteristics

Symbol	Parameter	Conditions	Min	Typ	Max	Unit
t_{FPP}	Page programming time	$f_{CLK_HSB} = 50\text{MHz}$		5		ms
t_{FPE}	Page erase time			5		
t_{FFP}	Fuse programming time			1		
t_{FEA}	Full chip erase time (EA)			5		
t_{FCE}	JTAG chip erase time (CHIP_ERASE)	$f_{CLK_HSB} = 115\text{kHz}$		170		

Table 7-20. Flash Endurance and Data Retention

Symbol	Parameter	Conditions	Min	Typ	Max	Unit
N_{FARRAY}	Array endurance (write/page)		100k			cycles
N_{FFUSE}	General Purpose fuses endurance (write/bit)		10k			
t_{RET}	Data retention		15			years

7.9 Analog Characteristics

7.9.1 Voltage Regulator Characteristics

Table 7-21. VREG Electrical Characteristics

Symbol	Parameter	Condition	Min	Typ	Max	Units
V_{VDDIN}	Input voltage range		1.98	3.3	3.6	V
$V_{VDDCORE}$	Output voltage, calibrated value	$V_{VDDIN} \geq 1.98V$		1.8		
	Output voltage accuracy	$I_{OUT} = 0.1\text{ mA to }60\text{ mA},$ $V_{VDDIN} > 2.2V$		2		%
		$I_{OUT} = 0.1\text{ mA to }60\text{ mA},$ $V_{VDDIN} = 1.98V\text{ to }2.2V$		4		
I_{OUT}	DC output current ⁽¹⁾	Normal mode			60	mA
		Low power mode			1	
I_{VREG}	Static current of internal regulator	Normal mode		20		μA
		Low power mode		6		

Note: 1. These values are based on simulation and characterization of other AVR microcontrollers manufactured in the same process technology. These values are not covered by test limits in production.

Table 7-22. Decoupling Requirements

Symbol	Parameter	Condition	Typ	Techno.	Units
C_{IN1}	Input regulator capacitor 1		33		nF
C_{IN2}	Input regulator capacitor 2		100		
C_{IN3}	Input regulator capacitor 3		10		μF
C_{OUT1}	Output regulator capacitor 1		100		nF
C_{OUT2}	Output regulator capacitor 2		2.2	Tantalum $0.5 < \text{ESR} < 10\text{Ohm}$	μF

Note: 1. Refer to [Section 6.1.2 on page 36](#).

7.9.2 Power-on Reset 18 Characteristics

Table 7-23. POR18 Characteristics

Symbol	Parameter	Condition	Min	Typ	Max	Units
V_{POT+}	Voltage threshold on $V_{VDDCORE}$ rising			1.45	1.58	V
V_{POT-}	Voltage threshold on $V_{VDDCORE}$ falling		1.2	1.32		
t_{DET}	Detection time	Time with $V_{VDDCORE} < V_{POT-}$ necessary to generate a reset signal		460		μs

Figure 7-5. POR18 Operating Principles

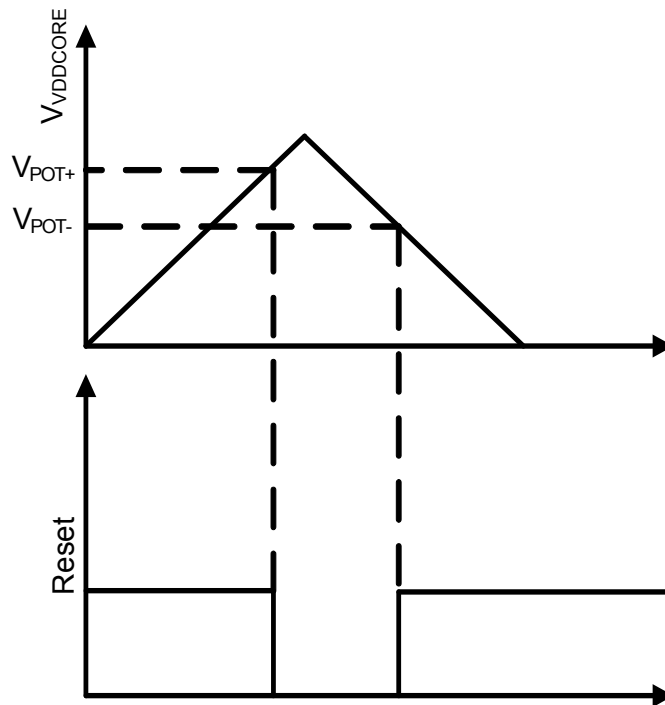

7.9.3 Power-on Reset 33 Characteristics

Table 7-24. POR33 Characteristics

Symbol	Parameter	Condition	Min	Typ	Max	Units
V_{POT+}	Voltage threshold on V_{DDIN} rising			1.49	1.58	V
V_{POT-}	Voltage threshold on V_{DDIN} falling		1.3	1.45		
t_{DET}	Detection time	Time with $V_{DDIN} < V_{POT-}$ necessary to generate a reset signal		460		μs
I_{POR33}	Current consumption	After t_{RESET}		15		μA
$t_{STARTUP}$	Startup time			400		μs

Figure 7-6. POR33 Operating Principles

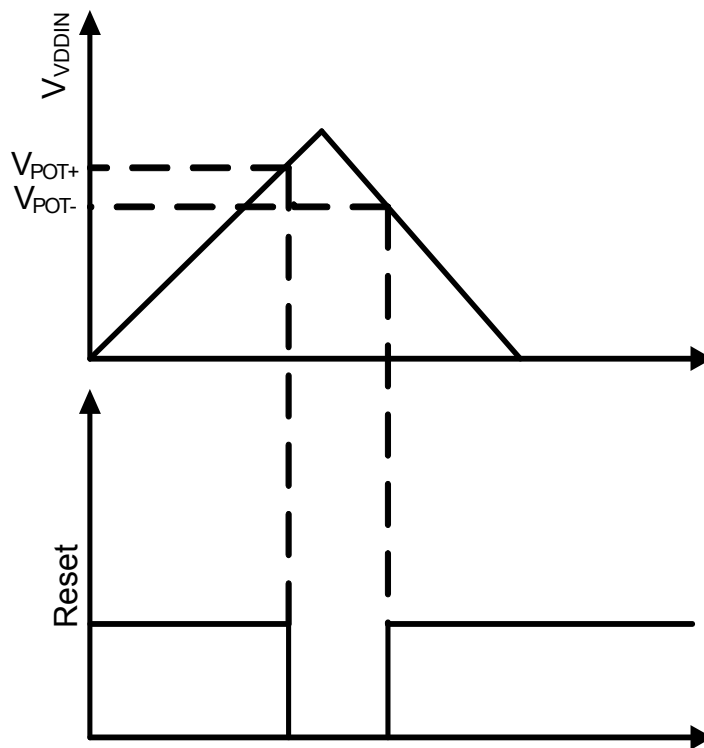

7.9.4 Brown Out Detector Characteristics

The values in Table 7-25 describe the values of the BODLEVEL in the flash General Purpose Fuse register.

Table 7-25. BODLEVEL Values

BODLEVEL Value	Min	Typ	Max	Units
011111 binary (31) 0x1F		1.56		V
100111 binary (39) 0x27		1.65		

Table 7-26. BOD Characteristics

Symbol	Parameter	Condition	Min	Typ	Max	Units
V_{HYST}	BOD hysteresis	$T = 25^{\circ}C$		10		mV
t_{DET}	Detection time	Time with $VDDCORE < BODLEVEL$ necessary to generate a reset signal		1		μs
I_{BOD}	Current consumption			16		μA
$t_{STARTUP}$	Startup time			5		μs

7.9.5 Supply Monitor 33 Characteristics

Table 7-27. SM33 Characteristics

Symbol	Parameter	Condition	Min	Typ	Max	Units
V_{TH}	Voltage threshold	Calibrated ⁽¹⁾ , $T = 25^{\circ}C$	1.675	1.75	1.825	V
	Step size, between adjacent values in SCIF.SM33.CALIB			11		mV
V_{HYST}	Hysteresis			30		
t_{DET}	Detection time	Time with $VDDIN < V_{TH}$ necessary to generate a reset signal		280		μs
I_{SM33}	Current consumption	Normal mode		15		μA
$t_{STARTUP}$	Startup time	Normal mode		140		μs

Note: 1. Calibration value can be read from the SCIF.SM33.CALIB field. This field is updated by the flash fuses after a reset. Refer to SCIF chapter for details.

7.9.6 Analog to Digital Converter Characteristics

Table 7-28. ADC Characteristics

Symbol	Parameter	Conditions	Min	Typ	Max	Units
f_{ADC}	ADC clock frequency	10-bit resolution mode			6	MHz
		8-bit resolution mode			6	
$t_{STARTUP}$	Startup time	Return from Idle Mode		15		μ s
t_{CONV}	Conversion time (latency)	$f_{ADC} = 6\text{MHz}$	11		26	cycles
	Throughput rate	$V_{VDD} > 3.0\text{V}$, $f_{ADC} = 6\text{MHz}$, 10-bit resolution mode, low impedance source			460	kSPS
		$V_{VDD} > 3.0\text{V}$, $f_{ADC} = 6\text{MHz}$, 8-bit resolution mode, low impedance source			460	
$V_{ADVREFP}$	Reference voltage range	$V_{ADVREFP} = V_{VDDANA}$	1.62		1.98	V
I_{ADC}	Current consumption on V_{VDDANA}	ADC Clock = 6MHz		300		μ A
$I_{ADVREFP}$	Current consumption on ADVREFP pin	$f_{ADC} = 6\text{MHz}$		250		

Note: These values are based on simulation and characterization of other AVR microcontrollers manufactured in the same process technology. These values are not covered by test limits in production.

7.9.6.1 Inputs and Sample and Hold Acquisition Time

Table 7-29. Analog Inputs

Symbol	Parameter	Conditions	Min	Typ	Max	Units
V_{ADn}	Input Voltage Range	10-bit mode	0		$V_{ADVREFP}$	V
		8-bit mode				
C_{ONCHIP}	Internal Capacitance ⁽¹⁾				21.5	pF
R_{ONCHIP}	Internal Resistance ⁽¹⁾	$V_{VDDIO} = 3.0\text{V to } 3.6\text{V}$, $V_{VDDCORE} = 1.8\text{V}$			2.55	kOhm
		$V_{VDDIO} = V_{VDDCORE} = 1.62\text{V to } 1.98\text{V}$			55.3	

Note: 1. These values are based on simulation and characterization of other AVR microcontrollers manufactured in the same process technology. These values are not covered by test limits in production.

An analog voltage input must be able to charge the sample and hold (S/H) capacitor in the ADC in order to achieve maximum accuracy. Seen externally the ADC input consists of a resistor (R_{ONCHIP}) and a capacitor (C_{ONCHIP}). In addition the resistance (R_{SOURCE}) and capacitance (C_{SOURCE}) of the PCB and source must be taken into account when calculating the sample and hold time. [Figure 7-7](#) shows the ADC input channel equivalent circuit.

Figure 7-7. ADC Input

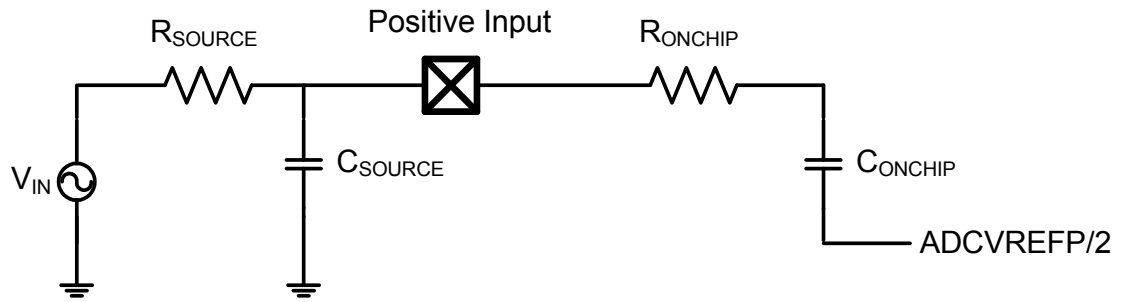

The minimum sample and hold time (in ns) can be found using this formula:

$$t_{SAMPLEHOLD} \geq (R_{ONCHIP} + R_{OFFCHIP}) \times (C_{ONCHIP} + C_{OFFCHIP}) \times \ln(2^{n+1})$$

Where n is the number of bits in the conversion. $t_{SAMPLEHOLD}$ is defined by the SHTIM field in the ADCIFB ACR register. Please refer to the ADCIFB chapter for more information.

7.9.6.2 Applicable Conditions and Derating Data

Table 7-30. Transfer Characteristics 10-bit Resolution Mode

Parameter	Conditions	Min	Typ	Max	Units
Resolution			10		Bit
Integral non-linearity	ADC clock frequency = 6MHz		+/-2		LSB
Differential non-linearity		-0.9		1	
Offset error			+/-4		
Gain error			+/-4		

Table 7-31. Transfer Characteristics 8-bit Resolution Mode

Parameter	Conditions	Min	Typ	Max	Units
Resolution			8		Bit
Integral non-linearity	ADC clock frequency = 6MHz		+/-0.5		LSB
Differential non-linearity		-0.23		0.25	
Offset error			+/-1		
Gain error			+/-1		

7.9.7 Temperature Sensor Characteristics

Table 7-32. Temperature Sensor Characteristics⁽¹⁾

Symbol	Parameter	Condition	Min	Typ	Max	Units
	Gradient			1		mV/°C
I _{TS}	Current consumption			0.5		μA
t _{STARTUP}	Startup time			0		μs

Note: 1. The Temperature Sensor is not calibrated. The accuracy of the Temperature Sensor is governed by the ADC accuracy.

7.9.8 Analog Comparator Characteristics

Table 7-33. Analog Comparator Characteristics

Symbol	Parameter	Condition	Min	Typ	Max	Units
	Positive input voltage range		-0.2		V _{VDDIO} + 0.3	V
	Negative input voltage range		-0.2		V _{VDDIO} - 0.6	
	Statistical offset	V _{ACREFN} = 1.0V, f _{AC} = 12MHz, filter length = 2, hysteresis = 0 ⁽¹⁾		20		mV
f _{AC}	Clock frequency for GCLK4				12	MHz
	Throughput rate ⁽³⁾	f _{AC} = 12MHz			12 000 000	Comparisons per second
	Propagation delay	Delay from input change to Interrupt Status Register Changes		$\left(\left\lceil \frac{1}{t_{CLKACIFB} \times f_{AC}} \right\rceil + 3 \right) \times t_{CLKACIFB}$		ns
I _{AC}	Current consumption	All channels, VDDIO = 3.3V, f _A = 3MHz		420		μA
t _{STARTUP}	Startup time			3		cycles
	Input current per pin			0.2		μA/MHz ⁽²⁾

Notes: 1. AC.CONFn.FLEN and AC.CONFn.HYS fields, refer to the Analog Comparator Interface chapter.

2. Referring to f_{AC}.

3. These values are based on simulation and characterization of other AVR microcontrollers manufactured in the same process technology. These values are not covered by test limits in production.

7.9.9 Capacitive Touch Characteristics

7.9.9.1 *Discharge Current Source*

Table 7-34. DICS Characteristics

Symbol	Parameter	Min	Typ	Max	Unit
R _{REF}	Internal resistor		120		kOhm
k	Trim step size		0.7		%

7.9.9.2 *Strong Pull-up Pull-down*

Table 7-35. Strong Pull-up Pull-down

Parameter	Min	Typ	Max	Unit
Pull-down resistor		1		kOhm
Pull-up resistor		1		

7.10 Timing Characteristics

7.10.1 Startup, Reset, and Wake-up Timing

The startup, reset, and wake-up timings are calculated using the following formula:

$$t = t_{CONST} + N_{CPU} \times t_{CPU}$$

Where t_{CONST} and N_{CPU} are found in [Table 7-36](#). t_{CPU} is the period of the CPU clock. If another clock source than RCSYS is selected as CPU clock the startup time of the oscillator, $t_{OSCSTART}$, must added to the wake-up time in the stop, deepstop, and static sleep modes. Please refer to the source for the CPU clock in the ["Oscillator Characteristics"](#) on [page 50](#) for more details about oscillator startup times.

Table 7-36. Maximum Reset and Wake-up Timing⁽¹⁾

Parameter		Measuring	Max t_{CONST} (in μ s)	Max N_{CPU}
Startup time from power-up, using regulator		Time from VDDIN crossing the V_{POT+} threshold of POR33 to the first instruction entering the decode stage of CPU. VDDCORE is supplied by the internal regulator.	2210	0
Startup time from power-up, no regulator		Time from VDDIN crossing the V_{POT+} threshold of POR33 to the first instruction entering the decode stage of CPU. VDDCORE is connected to VDDIN.	1810	0
Startup time from reset release		Time from releasing a reset source (except POR18, POR33, and SM33) to the first instruction entering the decode stage of CPU.	170	0
Wake-up	Idle	From wake-up event to the first instruction of an interrupt routine entering the decode stage of the CPU.	0	19
	Frozen		0	110
	Standby		0	110
	Stop		$27 + t_{OSCSTART}$	116
	Deepstop		$27 + t_{OSCSTART}$	116
	Static		$97 + t_{OSCSTART}$	116
Wake-up from shutdown		From wake-up event to the first instruction entering the decode stage of the CPU.	1180	0

Note: 1. These values are based on simulation and characterization of other AVR microcontrollers manufactured in the same process technology. These values are not covered by test limits in production.

7.10.2 RESET_N Timing

Table 7-37. RESET_N Waveform Parameters⁽¹⁾

Symbol	Parameter	Conditions	Min	Max	Units
t_{RESET}	RESET_N minimum pulse length		10		ns

Note: 1. These values are based on simulation and characterization of other AVR microcontrollers manufactured in the same process technology. These values are not covered by test limits in production.

7.10.3 USART in SPI Mode Timing

7.10.3.1 Master mode

Figure 7-8. USART in SPI Master Mode With (CPOL= CPHA= 0) or (CPOL= CPHA= 1)

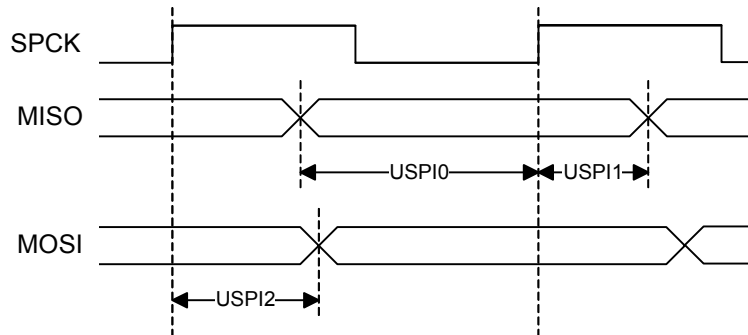

Figure 7-9. USART in SPI Master Mode With (CPOL= 0 and CPHA= 1) or (CPOL= 1 and CPHA= 0)

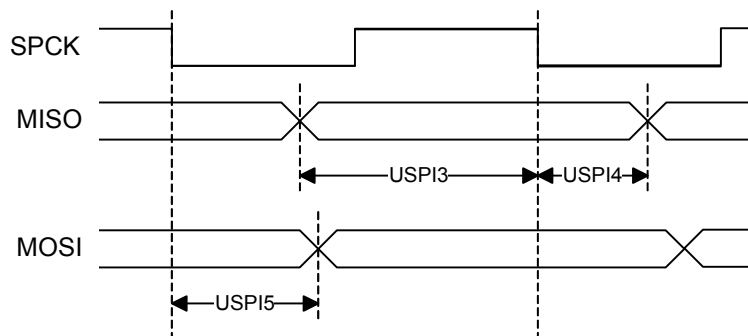

Table 7-38. USART in SPI Mode Timing, Master Mode⁽¹⁾

Symbol	Parameter	Conditions	Min	Max	Units
USPI0	MISO setup time before SPCK rises	V _{VDDIO} from 3.0V to 3.6V, maximum external capacitor = 40pF	30.0 + t _{SAMPLE} ⁽²⁾		ns
USPI1	MISO hold time after SPCK rises		0		
USPI2	SPCK rising to MOSI delay			8.5	
USPI3	MISO setup time before SPCK falls		25.5 + t _{SAMPLE} ⁽²⁾		
USPI4	MISO hold time after SPCK falls		0		
USPI5	SPCK falling to MOSI delay			13.6	

Notes: 1. These values are based on simulation and characterization of other AVR microcontrollers manufactured in the same process technology. These values are not covered by test limits in production.

2. Where: $t_{SAMPLE} = t_{SPCK} - \left(\frac{t_{SPCK}}{2 \times t_{CLKUSART}} \right) \times t_{CLKUSART}$

Maximum SPI Frequency, Master Output

The maximum SPI master output frequency is given by the following formula:

$$f_{SPCKMAX} = \text{MIN}\left(f_{PINMAX} \cdot \frac{1}{SPI_{in}}, \frac{f_{CLKSPI} \times 2}{9}\right)$$

Where SPI_{in} is the MOSI delay, USPI2 or USPI5 depending on CPOL and NCPHA. f_{PINMAX} is the maximum frequency of the SPI pins. Please refer to the I/O Pin Characteristics section for the maximum frequency of the pins. f_{CLKSPI} is the maximum frequency of the CLK_SPI. Refer to the SPI chapter for a description of this clock.

Maximum SPI Frequency, Master Input

The maximum SPI master input frequency is given by the following formula:

$$f_{SPCKMAX} = \text{MIN}\left(\frac{1}{SPI_{in} + t_{VALID}}, \frac{f_{CLKSPI} \times 2}{9}\right)$$

Where SPI_{in} is the MISO setup and hold time, USPI0 + USPI1 or USPI3 + USPI4 depending on CPOL and NCPHA. T_{VALID} is the SPI slave response time. Please refer to the SPI slave datasheet for T_{VALID} . f_{CLKSPI} is the maximum frequency of the CLK_SPI. Refer to the SPI chapter for a description of this clock.

7.10.3.2 Slave mode

Figure 7-10. USART in SPI Slave Mode With (CPOL= 0 and CPHA= 1) or (CPOL= 1 and CPHA= 0)

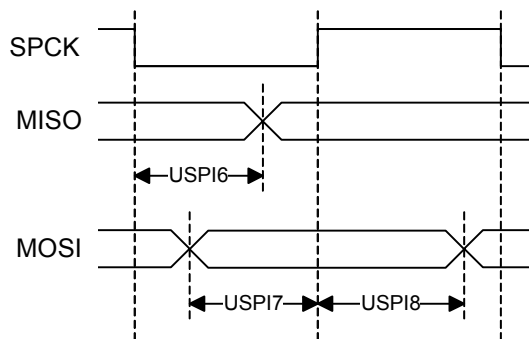

Figure 7-11. USART in SPI Slave Mode With (CPOL= CPHA= 0) or (CPOL= CPHA= 1)

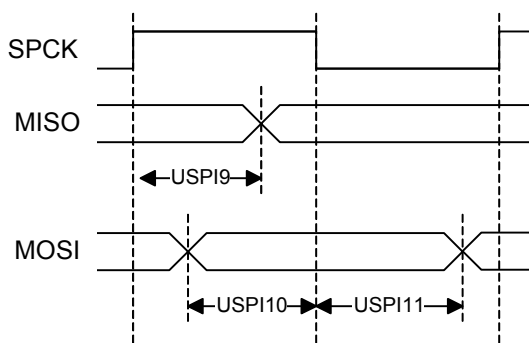

Figure 7-12. USART in SPI Slave Mode NPCS Timing

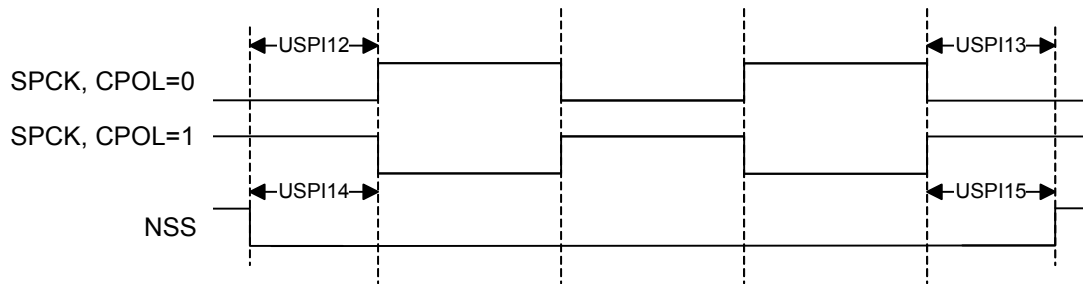

Table 7-39. USART in SPI mode Timing, Slave Mode⁽¹⁾

Symbol	Parameter	Conditions	Min	Max	Units
USPI6	SPCK falling to MISO delay	V _{VDDIO} from 3.0V to 3.6V, maximum external capacitor = 40pF		27.6	ns
USPI7	MOSI setup time before SPCK rises		t _{SAMPLE} ⁽²⁾ + t _{CLK_USART}		
USPI8	MOSI hold time after SPCK rises		0		
USPI9	SPCK rising to MISO delay			27.2	
USPI10	MOSI setup time before SPCK falls		t _{SAMPLE} ⁽²⁾ + t _{CLK_USART}		
USPI11	MOSI hold time after SPCK falls		0		
USPI12	NSS setup time before SPCK rises		25.0		
USPI13	NSS hold time after SPCK falls		0		
USPI14	NSS setup time before SPCK falls		25.0		
USPI15	NSS hold time after SPCK rises		0		

Notes: 1. These values are based on simulation and characterization of other AVR microcontrollers manufactured in the same process technology. These values are not covered by test limits in production.

2. Where: $t_{SAMPLE} = t_{SPCK} - \left(\left\lfloor \frac{t_{SPCK}}{2 \times t_{CLKUSART}} \right\rfloor + \frac{1}{2} \right) \times t_{CLKUSART}$

Maximum SPI Frequency, Slave Input Mode

The maximum SPI slave input frequency is given by the following formula:

$$f_{SPCKMAX} = MIN\left(\frac{f_{CLKSPI} \times 2}{9}, \frac{1}{SPI_{In}}\right)$$

Where SPI_{In} is the MOSI setup and hold time, USPI7 + USPI8 or USPI10 + USPI11 depending on CPOL and NCPHA. f_{CLKSPI} is the maximum frequency of the CLK_SPI. Refer to the SPI chapter for a description of this clock.

Maximum SPI Frequency, Slave Output Mode

The maximum SPI slave output frequency is given by the following formula:

$$f_{SPCKMAX} = \text{MIN}\left(\frac{f_{CLKSPI} \times 2}{9}, f_{PINMAX}, \frac{1}{SPI_{In} + t_{SETUP}}\right)$$

Where SPI_{In} is the MISO delay, USPI6 or USPI9 depending on CPOL and NCPHA. T_{SETUP} is the SPI master setup time. Please refer to the SPI master datasheet for $T_{SETUP} \cdot f_{CLKSPI}$ is the maximum frequency of the CLK_SPI. Refer to the SPI chapter for a description of this clock. f_{PINMAX} is the maximum frequency of the SPI pins. Please refer to the I/O Pin Characteristics section for the maximum frequency of the pins.

7.10.4 SPI Timing

7.10.4.1 Master mode

Figure 7-13. SPI Master Mode With (CPOL= NCPHA= 0) or (CPOL= NCPHA= 1)

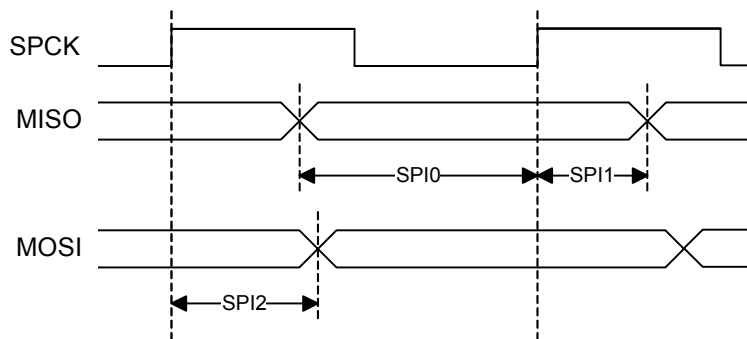

Figure 7-14. SPI Master Mode With (CPOL= 0 and NCPHA= 1) or (CPOL= 1 and NCPHA= 0)

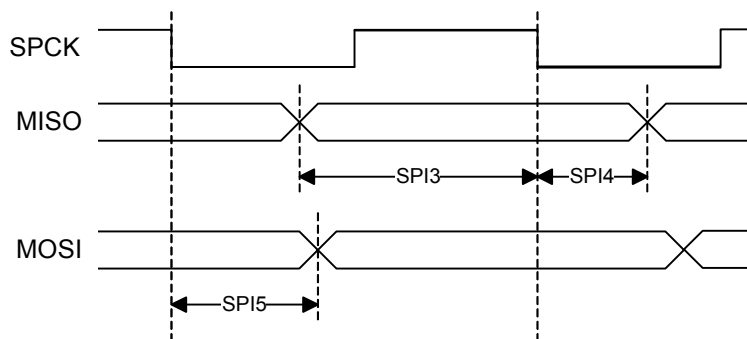

Table 7-40. SPI Timing, Master Mode⁽¹⁾

Symbol	Parameter	Conditions	Min	Max	Units
SPI0	MISO setup time before SPCK rises	V _{VDDIO} from 3.0V to 3.6V, maximum external capacitor = 40pF	28.4 + (t _{CLK_SPI})/2		ns
SPI1	MISO hold time after SPCK rises		0		
SPI2	SPCK rising to MOSI delay			7.1	
SPI3	MISO setup time before SPCK falls		22.8 + (t _{CLK_SPI})/2		
SPI4	MISO hold time after SPCK falls		0		
SPI5	SPCK falling to MOSI delay			11.0	

Note: 1. These values are based on simulation and characterization of other AVR microcontrollers manufactured in the same process technology. These values are not covered by test limits in production.

Maximum SPI Frequency, Master Output

The maximum SPI master output frequency is given by the following formula:

$$f_{SPCKMAX} = \text{MIN}(f_{PINMAX}, \frac{1}{SPI_n})$$

Where *SPI_n* is the MOSI delay, SPI2 or SPI5 depending on CPOL and NCPHA. *f_{PINMAX}* is the maximum frequency of the SPI pins. Please refer to the I/O Pin Characteristics section for the maximum frequency of the pins.

Maximum SPI Frequency, Master Input

The maximum SPI master input frequency is given by the following formula:

$$f_{SPCKMAX} = \frac{1}{SPI_n + t_{VALID}}$$

Where *SPI_n* is the MISO setup and hold time, SPI0 + SPI1 or SPI3 + SPI4 depending on CPOL and NCPHA. *t_{VALID}* is the SPI slave response time. Please refer to the SPI slave datasheet for *t_{VALID}*.

7.10.4.2 Slave mode

Figure 7-15. SPI Slave Mode With (CPOL= 0 and NCPHA= 1) or (CPOL= 1 and NCPHA= 0)

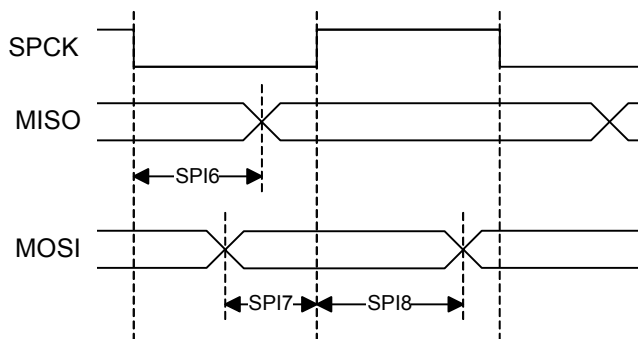

Figure 7-16. SPI Slave Mode With (CPOL= NCPHA= 0) or (CPOL= NCPHA= 1)

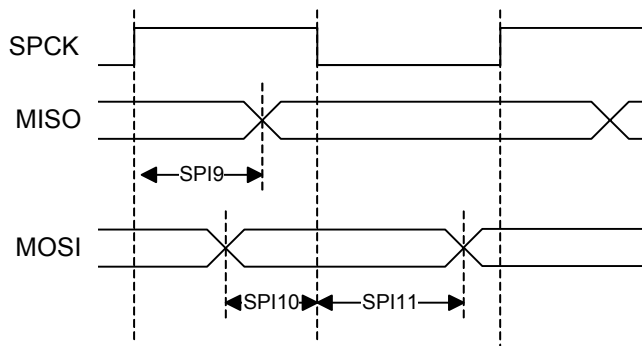

Figure 7-17. SPI Slave Mode NPCS Timing

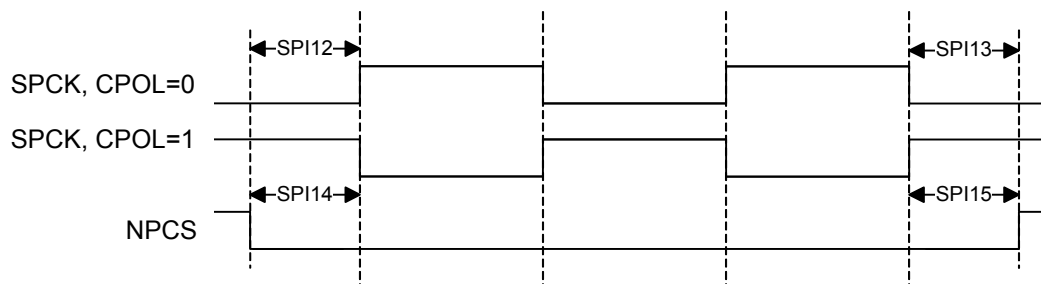

Table 7-41. SPI Timing, Slave Mode⁽¹⁾

Symbol	Parameter	Conditions	Min	Max	Units
SPI6	SPCK falling to MISO delay	V _{VDDIO} from 3.0V to 3.6V, maximum external capacitor = 40pF		79.9	ns
SPI7	MOSI setup time before SPCK rises		49.4		
SPI8	MOSI hold time after SPCK rises		4.1		
SPI9	SPCK rising to MISO delay			80.8	
SPI10	MOSI setup time before SPCK falls		48.8		
SPI11	MOSI hold time after SPCK falls		3.5		
SPI12	NPCS setup time before SPCK rises		4.9		
SPI13	NPCS hold time after SPCK falls		2.7		
SPI14	NPCS setup time before SPCK falls		3.8		
SPI15	NPCS hold time after SPCK rises		3.2		

Note: 1. These values are based on simulation and characterization of other AVR microcontrollers manufactured in the same process technology. These values are not covered by test limits in production.

Maximum SPI Frequency, Slave Input Mode

The maximum SPI slave input frequency is given by the following formula:

$$f_{SPCKMAX} = \text{MIN}(f_{CLKSPI}, \frac{1}{SPI_{In}})$$

Where SPI_{In} is the MOSI setup and hold time, $SPI7 + SPI8$ or $SPI10 + SPI11$ depending on CPOL and NCPHA. f_{CLKSPI} is the maximum frequency of the CLK_SPI. Refer to the SPI chapter for a description of this clock.

Maximum SPI Frequency, Slave Output Mode

The maximum SPI slave output frequency is given by the following formula:

$$f_{SPCKMAX} = \text{MIN}(f_{PINMAX}, \frac{1}{SPI_{In} + t_{SETUP}})$$

Where SPI_{In} is the MISO delay, SPI6 or SPI9 depending on CPOL and NCPHA. t_{SETUP} is the SPI master setup time. Please refer to the SPI master datasheet for t_{SETUP} . f_{PINMAX} is the maximum frequency of the SPI pins. Please refer to the I/O Pin Characteristics section for the maximum frequency of the pins.

7.10.5 TWIM/TWIS Timing

Figure 7-42 shows the TWI-bus timing requirements and the compliance of the device with them. Some of these requirements (t_r and t_f) are met by the device without requiring user intervention. Compliance with the other requirements (t_{HD-STA} , t_{SU-STA} , t_{SU-STO} , t_{HD-DAT} , $t_{SU-DAT-TWI}$, $t_{LOW-TWI}$, t_{HIGH} , and t_{TWCK}) requires user intervention through appropriate programming of the relevant TWIM and TWIS user interface registers. Please refer to the TWIM and TWIS sections for more information.

Table 7-42. TWI-Bus Timing Requirements

Symbol	Parameter	Mode	Minimum		Maximum		Unit
			Requirement	Device	Requirement	Device	
t_r	TWCK and TWD rise time	Standard ⁽¹⁾	-		1000		ns
		Fast ⁽¹⁾	$20 + 0.1C_b$		300		
t_f	TWCK and TWD fall time	Standard	-		300		ns
		Fast	$20 + 0.1C_b$		300		
t_{HD-STA}	(Repeated) START hold time	Standard	4	t_{clkpb}	-		μs
		Fast	0.6				
t_{SU-STA}	(Repeated) START set-up time	Standard	4.7	t_{clkpb}	-		μs
		Fast	0.6				
t_{SU-STO}	STOP set-up time	Standard	4.0	$4t_{clkpb}$	-		μs
		Fast	0.6				
t_{HD-DAT}	Data hold time	Standard	$0.3^{(2)}$	$2t_{clkpb}$	3.45^0	$15t_{prescaled} + t_{clkpb}$	μs
		Fast			0.9^0		

Table 7-42. TWI-Bus Timing Requirements

Symbol	Parameter	Mode	Minimum		Maximum		Unit
			Requirement	Device	Requirement	Device	
$t_{\text{SU-DAT-TWI}}$	Data set-up time	Standard	250	$2t_{\text{clkpb}}$	-		ns
		Fast	100				
$t_{\text{SU-DAT}}$		-	-	t_{clkpb}	-		-
$t_{\text{LOW-TWI}}$	TWCK LOW period	Standard	4.7	$4t_{\text{clkpb}}$	-		μs
		Fast	1.3				
t_{LOW}		-	-	t_{clkpb}	-		-
t_{HIGH}	TWCK HIGH period	Standard	4.0	$8t_{\text{clkpb}}$	-		μs
		Fast	0.6				
f_{TWCK}	TWCK frequency	Standard	-		100	$\frac{1}{12t_{\text{clkpb}}}$	kHz
		Fast			400		

- Notes:
1. Standard mode: $f_{\text{TWCK}} \leq 100 \text{ kHz}$; fast mode: $f_{\text{TWCK}} > 100 \text{ kHz}$.
 2. A device must internally provide a hold time of at least 300 ns for TWD with reference to the falling edge of TWCK.

Notations:

C_b = total capacitance of one bus line in pF

t_{clkpb} = period of TWI peripheral bus clock

$t_{\text{prescaled}}$ = period of TWI internal prescaled clock (see chapters on TWIM and TWIS)

The maximum $t_{\text{HD;DAT}}$ has only to be met if the device does not stretch the LOW period ($t_{\text{LOW-TWI}}$) of TWCK.

7.10.6 JTAG Timing

Figure 7-18. JTAG Interface Signals

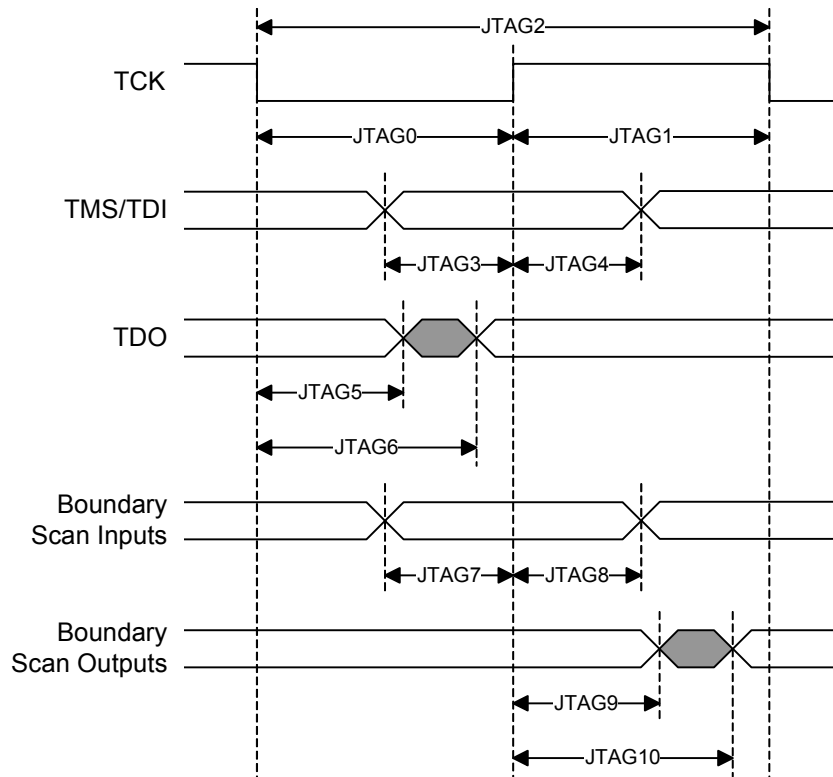

Table 7-43. JTAG Timings⁽¹⁾

Symbol	Parameter	Conditions	Min	Max	Units
JTAG0	TCK Low Half-period	V _{VDDIO} from 3.0V to 3.6V, maximum external capacitor = 40pF	23.2		ns
JTAG1	TCK High Half-period		8.8		
JTAG2	TCK Period		32.0		
JTAG3	TDI, TMS Setup before TCK High		3.9		
JTAG4	TDI, TMS Hold after TCK High		0.6		
JTAG5	TDO Hold Time		4.5		
JTAG6	TCK Low to TDO Valid			23.2	
JTAG7	Boundary Scan Inputs Setup Time		0		
JTAG8	Boundary Scan Inputs Hold Time		5.0		
JTAG9	Boundary Scan Outputs Hold Time		8.7		
JTAG10	TCK to Boundary Scan Outputs Valid		17.7		

Note: 1. These values are based on simulation and characterization of other AVR microcontrollers manufactured in the same process technology. These values are not covered by test limits in production.

8. Mechanical Characteristics

8.1 Thermal Considerations

8.1.1 Thermal Data

Table 8-1 summarizes the thermal resistance data depending on the package.

Table 8-1. Thermal Resistance Data

Symbol	Parameter	Condition	Package	Typ	Unit
θ_{JA}	Junction-to-ambient thermal resistance	Still Air	TQFP48	63.2	°C/W
θ_{JC}	Junction-to-case thermal resistance		TQFP48	21.8	
θ_{JA}	Junction-to-ambient thermal resistance	Still Air	QFN48	28.3	°C/W
θ_{JC}	Junction-to-case thermal resistance		QFN48	2.5	
θ_{JA}	Junction-to-ambient thermal resistance	Still Air	TLLGA48	30.06	°C/W
θ_{JC}	Junction-to-case thermal resistance		TLLGA48	TBD	

8.1.2 Junction Temperature

The average chip-junction temperature, T_J , in °C can be obtained from the following:

1. $T_J = T_A + (P_D \times \theta_{JA})$
2. $T_J = T_A + (P_D \times (\theta_{HEATSINK} + \theta_{JC}))$

where:

- θ_{JA} = package thermal resistance, Junction-to-ambient (°C/W), provided in [Table 8-1](#).
- θ_{JC} = package thermal resistance, Junction-to-case thermal resistance (°C/W), provided in [Table 8-1](#).
- $\theta_{HEAT\ SINK}$ = cooling device thermal resistance (°C/W), provided in the device datasheet.
- P_D = device power consumption (W) estimated from data provided in the [Section 7.5 on page 42](#).
- T_A = ambient temperature (°C).

From the first equation, the user can derive the estimated lifetime of the chip and decide if a cooling device is necessary or not. If a cooling device is to be fitted on the chip, the second equation should be used to compute the resulting average chip-junction temperature T_J in °C.

8.2 Package Drawings

Figure 8-1. TQFP-48 Package Drawing

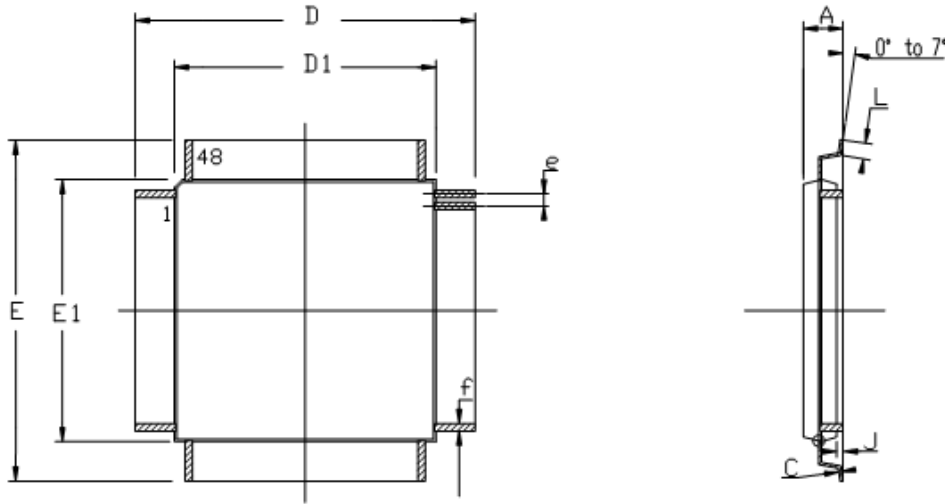

DRAWINGS NOT SCALED

COMMON DIMENSIONS IN MM

SYMBOL	Min	Max	NOTES
A	----	1.20	
A1	0.95	1.05	
C	0.09	0.20	
D	9.00 BSC		
D1	7.00 BSC		
E	9.00 BSC		
E1	7.00 BSC		
J	0.05	0.15	
L	0.45	0.75	
e	0.50 BSC		
f	0.17	0.27	

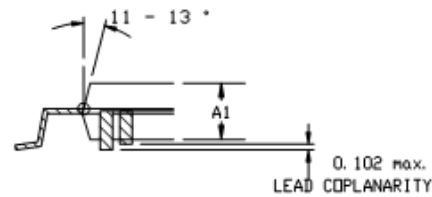

Table 8-2. Device and Package Maximum Weight

140	mg
-----	----

Table 8-3. Package Characteristics

Moisture Sensitivity Level	MSL3
----------------------------	------

Table 8-4. Package Reference

JEDEC Drawing Reference	MS-026
JESD97 Classification	E3

Figure 8-2. QFN-48 Package Drawing

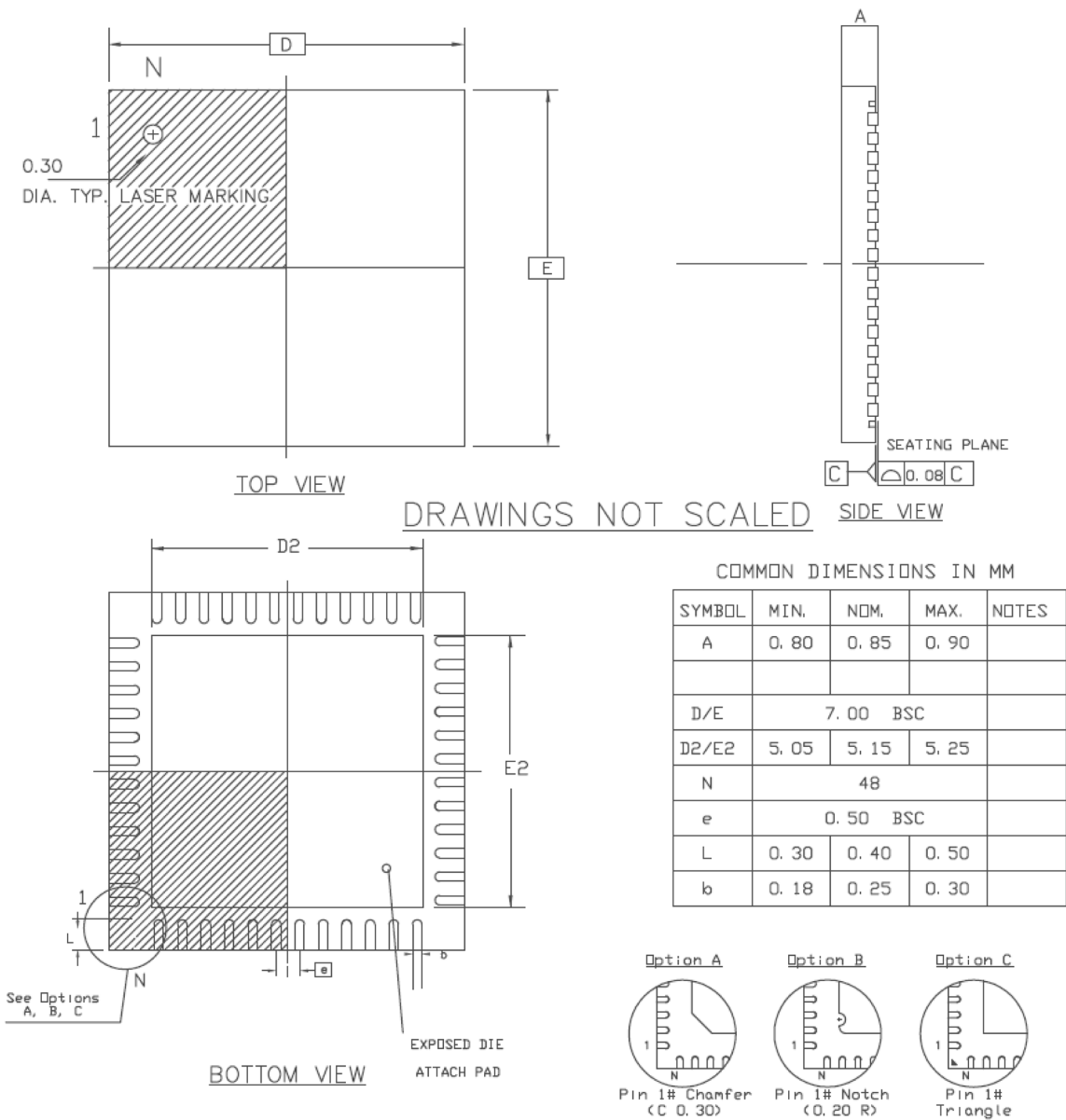

Note: The exposed pad is not connected to anything.

Table 8-5. Device and Package Maximum Weight

140	mg
-----	----

Table 8-6. Package Characteristics

Moisture Sensitivity Level	MSL3
----------------------------	------

Table 8-7. Package Reference

JEDEC Drawing Reference	M0-220
JESD97 Classification	E3

Figure 8-3. TLLGA-48 Package Drawing

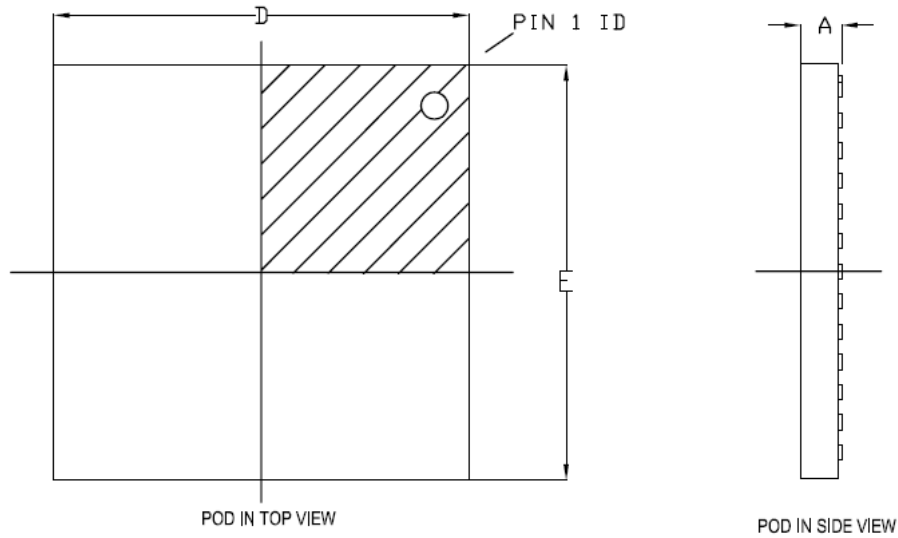

DRAWINGS NOT SCALED

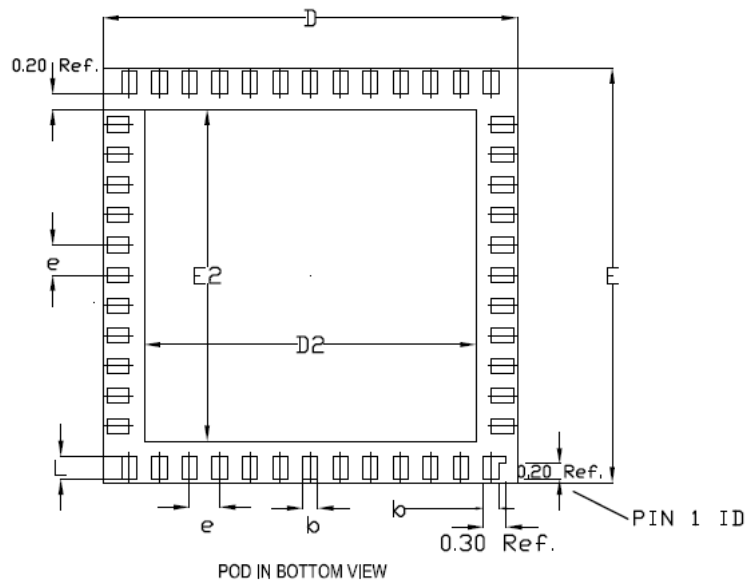

COMMON DIMENSIONS IN MM

SYMBOL	MIN.	NOM.	MAX.	NOTES
A	0.50	0.55	0.60	
J	----	----	----	
D/E	5.40	5.50	5.60	
D2/E2	4.30	4.40	4.50	
N	48			
e	0.40 BSC			
L	0.20	0.30	0.40	
b	0.15	0.20	0.25	

NOT RECOMMENDED TO MOUNT ON ANY FLEX OR FILM PCB OR MCM DEVICE WHICH REQUIRES SECOND MOLD ABOVE THIS PACKAGE

Table 8-8. Device and Package Maximum Weight

39.3	mg
------	----

Table 8-9. Package Characteristics

Moisture Sensitivity Level	MSL3
----------------------------	------

Table 8-10. Package Reference

JEDEC Drawing Reference	N/A
JESD97 Classification	E4

8.3 Soldering Profile

Table 8-11 gives the recommended soldering profile from J-STD-20.

Table 8-11. Soldering Profile

Profile Feature	Green Package
Average Ramp-up Rate (217°C to Peak)	3°C/s max
Preheat Temperature 175°C ±25°C	150-200°C
Time Maintained Above 217°C	60-150 s
Time within 5°C of Actual Peak Temperature	30 s
Peak Temperature Range	260°C
Ramp-down Rate	6°C/s max
Time 25°C to Peak Temperature	8 minutes max

A maximum of three reflow passes is allowed per component.

9. Ordering Information

Table 9-1. Ordering Information

Device	Ordering Code	Carrier Type	Package	Package Type	Temperature Operating Range	
AT32UC3L064	AT32UC3L064-AUTES	ES	TQFP 48	JESD97 Classification E3	Industrial (-40°C to 85°C)	
	AT32UC3L064-AUT	Tray				
	AT32UC3L064-AUR	Tape & Reel				
	AT32UC3L064-ZAUES	ES	QFN 48			
	AT32UC3L064-ZAUT	Tray				
	AT32UC3L064-ZAUR	Tape & Reel				
	AT32UC3L064-D3HES	ES	TLLGA 48			JESD97 Classification E4
	AT32UC3L064-D3HT	Tray				
	AT32UC3L064-D3HR	Tape & Reel				
AT32UC3L032	AT32UC3L032-AUT	Tray	TQFP 48	JESD97 Classification E3		
	AT32UC3L032-AUR	Tape & Reel				
	AT32UC3L032-ZAUT	Tray	QFN 48			
	AT32UC3L032-ZAUR	Tape & Reel				
	AT32UC3L032-D3HT	Tray	TLLGA 48		JESD97 Classification E4	
	AT32UC3L032-D3HR	Tape & Reel				
AT32UC3L016	AT32UC3L016-AUT	Tray	TQFP 48	JESD97 Classification E3		
	AT32UC3L016-AUR	Tape & Reel				
	AT32UC3L016-ZAUT	Tray	QFN 48			
	AT32UC3L016-ZAUR	Tape & Reel				
	AT32UC3L016-D3HT	Tray	TLLGA 48		JESD97 Classification E4	
	AT32UC3L016-D3HR	Tape & Reel				

10. Errata

10.1 Rev. E

10.1.1 Processor and Architecture

Hardware breakpoints may corrupt MAC results

Hardware breakpoints on MAC instructions may corrupt the destination register of the MAC instruction.

Fix/Workaround

Place breakpoints on earlier or later instructions.

Privilege violation when using interrupts in application mode with protected system stack

If the system stack is protected by the MPU and an interrupt occurs in application mode, an MPU DTLB exception will occur.

Fix/Workaround

Make a DTLB Protection (Write) exception handler which permits the interrupt request to be handled in privileged mode.

10.1.2 FLASHCDW

Flash self programming may fail in one wait state mode

Writes in flash and user pages may fail if executing code is located in address space mapped to flash, and the flash controller is configured in one wait state mode (the Flash Wait State bit in the Flash Control Register (FCR.FWS) is one).

Fix/Workaround

Solution 1: Configure the flash controller in zero wait state mode (FCR.FWS=0).

Solution 2: Configure the HMATRIX master 1 (CPU Instruction) to use the unlimited burst length transfer mode (MCFG1.ULBT=0), and the HMATRIX slave 0 (FLASHCDW) to use the maximum slot cycle limit (SCFG0.SLOT_CYCLE=255).

10.1.3 Power Manager

Clock sources will not be stopped in Static mode if the difference between CPU and PBx division factor is larger than 4

If the division factor between the CPU/HSB and PBx frequencies is more than 4 when entering a sleep mode where the system RC oscillator (RCSYS) is turned off, the high speed clock sources will not be turned off. This will result in a significantly higher power consumption during the sleep mode.

Fix/Workaround

Before going to sleep modes where RCSYS is stopped, make sure the division factor between CPU/HSB and PBx frequencies is less than or equal to 4.

Clock Failure Detector (CFD) can be issued while turning off the CFD

While turning off the CFD, the CFD bit in the Status Register (SR) can be set. This will change the main clock source to RCSYS.

Fix/Workaround

Solution 1: Enable CFD interrupt. If CFD interrupt is issues after turning off the CFD, switch back to original main clock source.

Solution 2: Only turn off the CFD while running the main clock on RCSYS.

Sleepwalking in idle and frozen sleep mode will mask all other PB clocks

If the CPU is in idle or frozen sleep mode and a module is in a state that triggers sleep walking, all PB clocks will be masked except the PB clock to the sleepwalking module.

Fix/Workaround

Mask all clock requests in the PM.PPCR register before going into idle or frozen mode.

10.1.4 SCIF

The FLO lock bit (FLOCR.LOCK) does not work

The FLO lock bit does not work and will always read as zero.

Fix/Workaround

Wait for 32 reference clock cycles after the tuner is enabled, then read the FLO.NOLOCK bit to check if it is set. If it is set, a lock can not be obtained for this configuration of reference clock and target ratio.

PCLKSR.OSC32RDY bit might not be cleared after disabling OSC32K

In some cases the OSC32RDY bit in the PCLKSR register will not be cleared when OSC32K is disabled.

Fix/Workaround

When re-enabling the OSC32K, read the PCLKSR.OSC32RDY bit. If this bit is:

0: Follow normal procedures.

1: Ignore the PCLKSR.OSC32RDY and ISR.OSC32RDY bit. Use the Frequency Meter (FREQM) to determine if the OSC32K clock is ready. The OSC32K clock is ready when the FREQM measures a non-zero frequency.

The RC32K output on PA20 is not always permanently disabled

The RC32K output on PA20 may sometimes re-appear.

Fix/Workaround

Before using RC32K for other purposes, the following procedure has to be followed in order to properly disable it:

- Run the CPU on RCSYS
- Disable the output to PA20 by writing a zero to PM.PPCR.RC32OUT
- Enable RC32K by writing a one to SCIF.RC32KCR.EN, and wait for this bit to be read as one
- Disable RC32K by writing a zero to SCIF.RC32KCR.EN, and wait for this bit to be read as zero.

10.1.5 AST

Reset may set status bits in the AST

If a reset occurs and the AST is enabled, the SR.ALARM0, SR.PER0, and SR.OVF bits may be set.

Fix/Workaround

If the part is reset and the AST is used, clear all bits in the Status Register before entering sleep mode.

AST wake signal is released one AST clock cycle after the BUSY bit is cleared

After writing to the Status Clear Register (SCR) the wake signal is released one AST clock cycle after the BUSY bit in the Status Register (SR.BUSY) is cleared. If entering sleep mode directly after the BUSY bit is cleared the part will wake up immediately.

Fix/Workaround

Read the Wake Enable Register (WER) and write this value back to the same register. Wait for BUSY to clear before entering sleep mode.

10.1.6 WDT

Clearing the Watchdog Timer (WDT) counter in second half of timeout period will issue a Watchdog reset

If the WDT counter is cleared in the second half of the timeout period, the WDT will immediately issue a Watchdog reset.

Fix/Workaround

Use twice as long timeout period as needed and clear the WDT counter within the first half of the timeout period. If the WDT counter is cleared after the first half of the timeout period, you will get a Watchdog reset immediately. If the WDT counter is not cleared at all, the time before the reset will be twice as long as needed.

10.1.7 GPIO

Clearing GPIO interrupt may fail

Writing a one to the GPIO.IFRC register to clear an interrupt will be ignored if interrupt is enabled for the corresponding port.

Fix/Workaround

Disable the interrupt, clear it by writing a one to GPIO.IFRC, then enable the interrupt.

10.1.8 SPI

SPI data transfer hangs with CSR0.CSAAT==1 and MR.MODFDIS==0

When CSR0.CSAAT==1 and mode fault detection is enabled (MR.MODFDIS==0), the SPI module will not start a data transfer.

Fix/Workaround

Disable mode fault detection by writing a one to MR.MODFDIS.

Disabling SPI has no effect on the SR.TDRE bit

Disabling SPI has no effect on the SR.TDRE bit whereas the write data command is filtered when SPI is disabled. Writing to TDR when SPI is disabled will not clear SR.TDRE. If SPI is disabled during a PDCA transfer, the PDCA will continue to write data to TDR until its buffer is empty, and this data will be lost.

Fix/Workaround

Disable the PDCA, add two NOPs, and disable the SPI. To continue the transfer, enable the SPI and PDCA.

SPI disable does not work in SLAVE mode

SPI disable does not work in SLAVE mode.

Fix/Workaround

Read the last received data, then perform a software reset by writing a one to the Software Reset bit in the Control Register (CR.SWRST).

SPI bad serial clock generation on 2nd chip_select when SCBR=1, CPOL=1, and NCPHA=0

When multiple chip selects (CS) are in use, if one of the baudrates equal 1 while one (CSRn.SCBR=1) of the others do not equal 1, and CSRn.CPOL=1 and CSRn.NCPHA=0, then an additional pulse will be generated on SCK.

Fix/Workaround

When multiple CS are in use, if one of the baudrates equals 1, the others must also equal 1 if CSRn.CPOL=1 and CSRn.NCPHA=0.

SPI mode fault detection enable causes incorrect behavior

When mode fault detection is enabled (MR.MODFDIS==0), the SPI module may not operate

properly.

Fix/Workaround

Always disable mode fault detection before using the SPI by writing a one to MR.MODFDIS.

SPI RDR.PCS is not correct

The PCS (Peripheral Chip Select) field in the SPI RDR (Receive Data Register) does not correctly indicate the value on the NPCS pins at the end of a transfer.

Fix/Workaround

Do not use the PCS field of the SPI RDR.

10.1.9 TWI

TWIM SR.IDLE goes high immediately when NAK is received

When a NAK is received and there is a non-zero number of bytes to be transmitted, SR.IDLE goes high immediately and does not wait for the STOP condition to be sent. This does not cause any problem just by itself, but can cause a problem if software waits for SR.IDLE to go high and then immediately disables the TWIM by writing a one to CR.MDIS. Disabling the TWIM causes the TWCK and TWD pins to go high immediately, so the STOP condition will not be transmitted correctly.

Fix/Workaround

If possible, do not disable the TWIM. If it is absolutely necessary to disable the TWIM, there must be a software delay of at least two TWCK periods between the detection of SR.IDLE==1 and the disabling of the TWIM.

TWIM TWALM polarity is wrong

The TWALM signal in the TWIM is active high instead of active low.

Fix/Workaround

Use an external inverter to invert the signal going into the TWIM. When using both TWIM and TWIS on the same pins, the TWALM cannot be used.

TWIS may not wake the device from sleep mode

If the CPU is put to a sleep mode (except Idle and Frozen) directly after a TWI Start condition, the CPU may not wake upon a TWIS address match. The request is NACKed.

Fix/Workaround

When using the TWI address match to wake the device from sleep, do not switch to sleep modes deeper than Frozen. Another solution is to enable asynchronous EIC wake on the TWIS clock (TWCK) or TWIS data (TWD) pins, in order to wake the system up on bus events.

PWMA

BUSY bit is never cleared after writes to the Control Register (CR)

When writing a non-zero value to CR.TOP, CR.SPREAD, or CR.TCLR when the PWMA is disabled (CR.EN == 0), the BUSY bit in the Status Register (SR.BUSY) will be set, but never cleared.

Fix/Workaround

When writing a non-zero value to CR.TOP, CR.SPREAD, or CR.TCLR, make sure the PWMA is enabled, or simultaneously enable the PWMA by writing a one to CR.EN.

Incoming peripheral events are discarded during duty cycle register update

Incoming peripheral events to all applied channels will be discarded if a duty cycle update is received from the user interface in the same PWMA clock period.

Fix/Workaround

Ensure that duty cycle writes from the user interface are not performed in a PWMA period when an incoming peripheral event is expected.

10.1.10 ADCIFB

Using STARTUPTIME larger than 0x1F will freeze the ADC

Writing a value larger than 0x1F to the Startup Time field in the ADC Configuration Register (ACR.STARTUP) will freeze the ADC, and the Busy Status bit in the Status Register (SR.BUSY) will never be cleared.

Fix/Workaround

Do not write values larger than 0x1F to ACR.STARTUP.

10.1.11 CAT

CAT asynchronous wake will be delayed by one AST event period

If the CAT detects a condition the should asynchronously wake the device in static mode, the asynchronous wake will not occur until the next AST event. For example, if the AST is generating events to the CAT every 50ms, and the CAT detects a touch at t=9200ms, the asynchronous wake will occur at t=9250ms.

Fix/Workaround

None.

CAT QMatrix sense capacitors discharged prematurely

At the end of a QMatrix burst charging sequence that uses different burst count values for different Y lines, the Y lines may be incorrectly grounded for up to n-1 periods of the peripheral bus clock, where n is the ratio of the PB clock frequency to the GCLK_CAT frequency. This results in premature loss of charge from the sense capacitors and thus increased variability of the acquired count values.

Fix/Workaround

Enable the 1kOhm drive resistors on all implemented QMatrix Y lines (CSA 1, 3, 5, 7, 9, 11, 13, and/or 15) by writing ones to the corresponding odd bits of the CSARES register.

10.1.12 aWire

aWire CPU clock speed robustness

The aWire memory speed request command counter warps at clock speeds below approximately 5kHz.

Fix/Workaround

None.

The aWire debug interface is reset after leaving Shutdown mode

If the aWire debug mode is used as debug interface and the program enters Shutdown mode, the aWire interface will be reset when the part receives a wakeup either from the WAKE_N pin or the AST.

Fix/Workaround

None.

10.1.13 CHIP

Increased Power Consumption in VDDIO in sleep modes

If OSC0 is enabled in crystal mode when entering a sleep mode where the OSC0 is disabled, this will lead to an increased power consumption in VDDIO.

Fix/Workaround

Solution 1: Disable OSC0 by writing a zero to the Oscillator Enable bit in the System Control Interface (SCIF) Oscillator Control Register (SCIF.OSC0CTRL.OSCEN) before going to a sleep mode where OSC0 is disabled.

Solution 2: Pull down or up XIN0 or XOUT0 with 1M Ω resistor.

10.1.14 I/O Pins

PA17 has low ESD tolerance

PA17 only tolerates 500V ESD pulses (Human Body Model).

Fix/Workaround

Care must be taken during manufacturing and PCB design.

10.2 Rev. D

10.2.1 Processor and Architecture

Hardware breakpoints may corrupt MAC results

Hardware breakpoints on MAC instructions may corrupt the destination register of the MAC instruction.

Fix/Workaround

Place breakpoints on earlier or later instructions.

Privilege violation when using interrupts in application mode with protected system stack

If the system stack is protected by the MPU and an interrupt occurs in application mode, an MPU DTLB exception will occur.

Fix/Workaround

Make a DTLB Protection (Write) exception handler which permits the interrupt request to be handled in privileged mode.

10.2.2 FLASHCDW

Flash self programming may fail in one wait state mode

Writes in flash and user pages may fail if executing code is located in address space mapped to flash, and the flash controller is configured in one wait state mode (the Flash Wait State bit in the Flash Control Register (FCR.FWS) is one).

Fix/Workaround

Solution 1: Configure the flash controller in zero wait state mode (FCR.FWS=0).

Solution 2: Configure the HMATRIX master 1 (CPU Instruction) to use the unlimited burst length transfer mode (MCFG1.ULBT=0), and the HMATRIX slave 0 (FLASHCDW) to use the maximum slot cycle limit (SCFG0.SLOT_CYCLE=255).

10.2.3 Power Manager

Clock sources will not be stopped in Static mode if the difference between CPU and PBx division factor is larger than 4

If the division factor between the CPU/HSB and PBx frequencies is more than 4 when entering a sleep mode where the system RC oscillator (RCSYS) is turned off, the high speed clock sources will not be turned off. This will result in a significantly higher power consumption during the sleep mode.

Fix/Workaround

Before going to sleep modes where RCSYS is stopped, make sure the division factor between CPU/HSB and PBx frequencies is less than or equal to 4.

External reset in Shutdown mode

If an external reset is asserted while the device is in Shutdown mode, the Power Manager will register this as a Power-on reset (POR), and not as a SLEEP reset, in the Reset Cause register (RCAUSE)

Fix/Workaround

None.

Disabling POR33 may generate spurious resets

Depending on operating conditions, POR33 may generate a spurious reset in one of the following cases:

- When POR33 is disabled from the user interface
- When SM33 supply monitor is enabled
- When entering Shutdown mode while debugging the chip using JTAG or aWire interface

In the listed cases, writing a one to the bit VREGCR.POR33MASK in the System Control Interface (SCIF) to mask the POR33 reset will be ineffective

Fix/Workaround

- Do not disable POR33 using the user interface
- Do not use the SM33 supply monitor
- Do not enter Shutdown mode if a debugger is connected to the chip

Instability when exiting sleep walking

If all the following operating conditions are true, exiting sleep walking might lead to instability:

- The OSC0 is enabled in external clock mode (OSCCTRL0.OSCEN == 1 and OSCCTRL0.MODE == 0)
- A sleep mode where the OSC0 is automatically disabled is entered
- The device enters sleep walking

Fix/Workaround

Do not run OSC0 in external clock mode if sleepwalking is expected to be used.

Clock Failure Detector (CFD) can be issued while turning off the CFD

While turning off the CFD, the CFD bit in the Status Register (SR) can be set. This will change the main clock source to RCSYS.

Fix/Workaround

Solution 1: Enable CFD interrupt. If CFD interrupt is issues after turning off the CFD, switch back to original main clock source.

Solution 2: Only turn off the CFD while running the main clock on RCSYS.

Sleepwalking in idle and frozen sleep mode will mask all other PB clocks

If the CPU is in idle or frozen sleep mode and a module is in a state that triggers sleep walking, all PB clocks will be masked except the PB clock to the sleepwalking module.

Fix/Workaround

Mask all clock requests in the PM.PPCR register before going into idle or frozen mode.

10.2.4 SCIF

The FLO lock bit (FLOCR.LOCK) does not work

The FLO lock bit does not work and will always read as zero.

Fix/Workaround

Wait for 32 reference clock cycles after the tuner is enabled, then read the FLO.NOLOCK bit to check if it is set. If it is set, a lock can not be obtained for this configuration of reference clock and target ratio.

PCLKSR.OSC32RDY bit might not be cleared after disabling OSC32K

In some cases the OSC32RDY bit in the PCLKSR register will not be cleared when OSC32K is disabled.

Fix/Workaround

When re-enabling the OSC32K, read the PCLKSR.OSC32RDY bit. If this bit is:

0: Follow normal procedures.

1: Ignore the PCLKSR.OSC32RDY and ISR.OSC32RDY bit. Use the Frequency Meter (FREQM) to determine if the OSC32K clock is ready. The OSC32K clock is ready when the FREQM measures a non-zero frequency.

The RC32K output on PA20 is not always permanently disabled

The RC32K output on PA20 may sometimes re-appear.

Fix/Workaround

Before using RC32K for other purposes, the following procedure has to be followed in order to properly disable it:

- Run the CPU on RCSYS
- Disable the output to PA20 by writing a zero to PM.PPCR.RC32OUT
- Enable RC32K by writing a one to SCIF.RC32KCR.EN, and wait for this bit to be read as one
- Disable RC32K by writing a zero to SCIF.RC32KCR.EN, and wait for this bit to be read as zero.

10.2.5 AST

Reset may set status bits in the AST

If a reset occurs and the AST is enabled, the SR.ALARM0, SR.PER0, and SR.OVF bits may be set.

Fix/Workaround

If the part is reset and the AST is used, clear all bits in the Status Register before entering sleep mode.

AST wake signal is released one AST clock cycle after the BUSY bit is cleared

After writing to the Status Clear Register (SCR) the wake signal is released one AST clock cycle after the BUSY bit in the Status Register (SR.BUSY) is cleared. If entering sleep mode directly after the BUSY bit is cleared the part will wake up immediately.

Fix/Workaround

Read the Wake Enable Register (WER) and write this value back to the same register. Wait for BUSY to clear before entering sleep mode.

10.2.6 WDT

Clearing the Watchdog Timer (WDT) counter in second half of timeout period will issue a Watchdog reset

If the WDT counter is cleared in the second half of the timeout period, the WDT will immediately issue a Watchdog reset.

Fix/Workaround

Use twice as long timeout period as needed and clear the WDT counter within the first half of the timeout period. If the WDT counter is cleared after the first half of the timeout period, you will get a Watchdog reset immediately. If the WDT counter is not cleared at all, the time before the reset will be twice as long as needed.

10.2.7 GPIO

Clearing GPIO interrupt may fail

Writing a one to the GPIO.IFRC register to clear an interrupt will be ignored if interrupt is enabled for the corresponding port.

Fix/Workaround

Disable the interrupt, clear it by writing a one to GPIO.IFRC, then enable the interrupt.

10.2.8 SPI

SPI data transfer hangs with CSR0.CSAAT==1 and MR.MODFDIS==0

When CSR0.CSAAT==1 and mode fault detection is enabled (MR.MODFDIS==0), the SPI module will not start a data transfer.

Fix/Workaround

Disable mode fault detection by writing a one to MR.MODFDIS.

Disabling SPI has no effect on the SR.TDRE bit

Disabling SPI has no effect on the SR.TDRE bit whereas the write data command is filtered when SPI is disabled. Writing to TDR when SPI is disabled will not clear SR.TDRE. If SPI is disabled during a PDCA transfer, the PDCA will continue to write data to TDR until its buffer is empty, and this data will be lost.

Fix/Workaround

Disable the PDCA, add two NOPs, and disable the SPI. To continue the transfer, enable the SPI and PDCA.

SPI disable does not work in SLAVE mode

SPI disable does not work in SLAVE mode.

Fix/Workaround

Read the last received data, then perform a software reset by writing a one to the Software Reset bit in the Control Register (CR.SWRST).

SPI bad serial clock generation on 2nd chip_select when SCBR=1, CPOL=1, and NCPHA=0

When multiple chip selects (CS) are in use, if one of the baudrates equal 1 while one (CSRn.SCBR=1) of the others do not equal 1, and CSRn.CPOL=1 and CSRn.NCPHA=0, then an additional pulse will be generated on SCK.

Fix/Workaround

When multiple CS are in use, if one of the baudrates equals 1, the others must also equal 1 if CSRn.CPOL=1 and CSRn.NCPHA=0.

SPI mode fault detection enable causes incorrect behavior

When mode fault detection is enabled (MR.MODFDIS==0), the SPI module may not operate properly.

Fix/Workaround

Always disable mode fault detection before using the SPI by writing a one to MR.MODFDIS.

SPI RDR.PCS is not correct

The PCS (Peripheral Chip Select) field in the SPI RDR (Receive Data Register) does not correctly indicate the value on the NPCS pins at the end of a transfer.

Fix/Workaround

Do not use the PCS field of the SPI RDR.

10.2.9 TWI

TWIM SR.IDLE goes high immediately when NAK is received

When a NAK is received and there is a non-zero number of bytes to be transmitted, SR.IDLE goes high immediately and does not wait for the STOP condition to be sent. This does not cause any problem just by itself, but can cause a problem if software waits for SR.IDLE to go high and then immediately disables the TWIM by writing a one to CR.MDIS. Disabling the TWIM causes the TWCK and TWD pins to go high immediately, so the STOP condition will not be transmitted correctly.

Fix/Workaround

If possible, do not disable the TWIM. If it is absolutely necessary to disable the TWIM, there must be a software delay of at least two TWCK periods between the detection of SR.IDLE==1 and the disabling of the TWIM.

TWIM TWALM polarity is wrong

The TWALM signal in the TWIM is active high instead of active low.

Fix/Workaround

Use an external inverter to invert the signal going into the TWIM. When using both TWIM and TWIS on the same pins, the TWALM cannot be used.

TWIS may not wake the device from sleep mode

If the CPU is put to a sleep mode (except Idle and Frozen) directly after a TWI Start condition, the CPU may not wake upon a TWIS address match. The request is NACKed.

Fix/Workaround

When using the TWI address match to wake the device from sleep, do not switch to sleep modes deeper than Frozen. Another solution is to enable asynchronous EIC wake on the TWIS clock (TWCK) or TWIS data (TWD) pins, in order to wake the system up on bus events.

PWMA

BUSY bit is never cleared after writes to the Control Register (CR)

When writing a non-zero value to CR.TOP, CR.SPREAD, or CR.TCLR when the PWMA is disabled (CR.EN == 0), the BUSY bit in the Status Register (SR.BUSY) will be set, but never cleared.

Fix/Workaround

When writing a non-zero value to CR.TOP, CR.SPREAD, or CR.TCLR, make sure the PWMA is enabled, or simultaneously enable the PWMA by writing a one to CR.EN.

Incoming peripheral events are discarded during duty cycle register update

Incoming peripheral events to all applied channels will be discarded if a duty cycle update is received from the user interface in the same PWMA clock period.

Fix/Workaround

Ensure that duty cycle writes from the user interface are not performed in a PWMA period when an incoming peripheral event is expected.

10.2.10 ADCIFB

Using STARTUPTIME larger than 0x1F will freeze the ADC

Writing a value larger than 0x1F to the Startup Time field in the ADC Configuration Register (ACR.STARTUP) will freeze the ADC, and the Busy Status bit in the Status Register (SR.BUSY) will never be cleared.

Fix/Workaround

Do not write values larger than 0x1F to ACR.STARTUP.

10.2.11 CAT

CAT asynchronous wake will be delayed by one AST event period

If the CAT detects a condition the should asynchronously wake the device in static mode, the asynchronous wake will not occur until the next AST event. For example, if the AST is generating events to the CAT every 50ms, and the CAT detects a touch at t=9200ms, the asynchronous wake will occur at t=9250ms.

Fix/Workaround

None.

CAT QMatrix sense capacitors discharged prematurely

At the end of a QMatrix burst charging sequence that uses different burst count values for different Y lines, the Y lines may be incorrectly grounded for up to n-1 periods of the peripheral bus clock, where n is the ratio of the PB clock frequency to the GCLK_CAT frequency. This results in premature loss of charge from the sense capacitors and thus increased variability of the acquired count values.

Fix/Workaround

Enable the 1kOhm drive resistors on all implemented QMatrix Y lines (CSA 1, 3, 5, 7, 9, 11, 13, and/or 15) by writing ones to the corresponding odd bits of the CSARES register.

10.2.12 aWire

aWire CPU clock speed robustness

The aWire memory speed request command counter warps at clock speeds below approximately 5kHz.

Fix/Workaround

None.

The aWire debug interface is reset after leaving Shutdown mode

If the aWire debug mode is used as debug interface and the program enters Shutdown mode, the aWire interface will be reset when the part receives a wakeup either from the WAKE_N pin or the AST.

Fix/Workaround

None.

10.2.13 CHIP

In 3.3V Single Supply Mode, the Analog Comparator inputs affects the device's ability to start

When using the 3.3V Single Supply Mode the state of the Analog Comparator input pins can affect the device's ability to release POR reset. This is due to an interaction between the Analog Comparator input pins and the POR circuitry. The issue is not present in the 1.8V Supply Mode or the 3.3V Supply Mode with 1.8V Regulated I/O Lines.

Fix/Workaround

ACREFN (pin PA16) must be connected to GND until the POR reset is released and the Analog Comparator inputs should not be driven higher than 1.0V until the POR reset is released.

Increased Power Consumption in VDDIO in sleep modes

If OSC0 is enabled in crystal mode when entering a sleep mode where the OSC0 is disabled, this will lead to an increased power consumption in VDDIO.

Fix/Workaround

Solution 1: Disable OSC0 by writing a zero to the Oscillator Enable bit in the System Control Interface (SCIF) Oscillator Control Register (SCIF.OSC0CTRL.OSCEN) before going to a sleep mode where OSC0 is disabled.

Solution 2: Pull down or up XIN0 or XOUT0 with 1MΩ resistor.

10.2.14 I/O Pins

PA17 has low ESD tolerance

PA17 only tolerates 500V ESD pulses (Human Body Model).

Fix/Workaround

Care must be taken during manufacturing and PCB design.

10.3 Rev. C

Not sampled.

10.4 Rev. B

10.4.1 Processor and Architecture

RETS behaves incorrectly when MPU is enabled

RETS behaves incorrectly when MPU is enabled and MPU is configured so that system stack is not readable in unprivileged mode.

Fix/Workaround

Make system stack readable in unprivileged mode, or return from supervisor mode using rete instead of rets. This requires:

1. Changing the mode bits from 001 to 110 before issuing the instruction. Updating the mode bits to the desired value must be done using a single mtsr instruction so it is done atomically. Even if this step is generally described as not safe in the UC technical reference manual, it is safe in this very specific case.
2. Execute the RETE instruction.

Hardware breakpoints may corrupt MAC results

Hardware breakpoints on MAC instructions may corrupt the destination register of the MAC instruction.

Fix/Workaround

Place breakpoints on earlier or later instructions.

Privilege violation when using interrupts in application mode with protected system stack

If the system stack is protected by the MPU and an interrupt occurs in application mode, an MPU DTLB exception will occur.

Fix/Workaround

Make a DTLB Protection (Write) exception handler which permits the interrupt request to be handled in privileged mode.

10.4.2 PDCA

PCONTROL.CHxRES is non-functional

PCONTROL.CHxRES is non-functional. Counters are reset at power-on, and cannot be reset by software.

Fix/Workaround

Software needs to keep history of performance counters.

Transfer error will stall a transmit peripheral handshake interface

If a transfer error is encountered on a channel transmitting to a peripheral, the peripheral handshake of the active channel will stall and the PDCA will not do any more transfers on the affected peripheral handshake interface.

Fix/Workaround

Disable and then enable the peripheral after the transfer error.

VERSION register reads 0x120

The VERSION register reads 0x120 instead of 0x122.

Fix/Workaround

None.

10.4.3 FLASHCDW**Chip Erase**

When performing a chip erase, the device may report that it is protected (IR=0x11) and that the erase failed, even if it was successful.

Fix/Workaround

Perform a reset before any further read and programming.

Fuse Programming

Programming fuses does not work.

Fix/Workaround

Do not program fuses. All fuses will be erased during chip erase command.

Wait 500 ns before reading from the flash after switching read mode

After switching between normal read mode and high-speed read mode, the application must wait at least 500ns before attempting any access to the flash.

Fix/Workaround

Solution 1: Make sure that the appropriate instructions are executed from RAM, and that a waiting-loop is executed from RAM waiting 500ns or more before executing from flash.

Solution 2. Execute from flash with a clock with period longer than 500ns. This guarantees that no new read access is attempted before the flash has had time to settle in the new read mode.

Flash self programming may fail in one wait state mode

Writes in flash and user pages may fail if executing code is located in address space mapped to flash, and the flash controller is configured in one wait state mode (the Flash Wait State bit in the Flash Control Register (FCR.FWS) is one).

Fix/Workaround

Solution 1: Configure the flash controller in zero wait state mode (FCR.FWS=0).

Solution 2: Configure the HMATRIX master 1 (CPU Instruction) to use the unlimited burst length transfer mode (MCFG1.ULBT=0), and the HMATRIX slave 0 (FLASHCDW) to use the maximum slot cycle limit (SCFG0.SLOT_CYCLE=255).

VERSION register reads 0x100

The VERSION register reads 0x100 instead of 0x102.

Fix/Workaround

None.

10.4.4 SAU**The SR.IDLE bit reads as zero**

The IDLE bit in the Status Register (SR.IDLE) reads as zero.

Fix/Workaround

None.

Open Mode is not functional

The Open Mode is not functional.

Fix/Workaround

None.

VERSION register reads 0x100

The VERSION register reads 0x100 instead of 0x110.

Fix/Workaround

None.

10.4.5 HMATRIX**In the PRAS and PRBS registers, the MxPR fields are only two bits**

In the PRAS and PRBS registers, the MxPR fields are only two bits wide, instead of four bits.

The unused bits are undefined when reading the registers.

Fix/Workaround

Mask undefined bits when reading PRAS and PRBS.

10.4.6 Power Manager**CONFIG register reads 0x4F**

The CONFIG register reads 0x4F instead of 0x43.

Fix/Workaround

None.

If is not possible to mask the request clock requests

If is not possible to mask the request clock requests using PPCR.

Fix/Workaround

None.

Static mode cannot be entered if the WDT is using OSC32

If the WDT is using OSC32 as clock source and the user tries to enter Static mode, the Deepstop mode will be entered instead.

Fix/Workaround

None.

Clock Failure Detector (CFD) does not work

Clock Failure Detector (CFD) does not work.

Fix/Workaround

None.

WCAUSE register should not be used

The WCAUSE register should not be used.

Fix/Workaround

None.

PB writes via debugger in sleep modes are blocked during sleepwalking

During sleepwalking, PB writes performed by a debugger will be discarded by all PB modules except the module that is requesting the clock.

Fix/Workaround

None.

Clock sources will not be stopped in Static mode if the difference between CPU and PBx division factor is larger than 4

If the division factor between the CPU/HSB and PBx frequencies is more than 4 when entering a sleep mode where the system RC oscillator (RCSYS) is turned off, the high speed clock sources will not be turned off. This will result in a significantly higher power consumption during the sleep mode.

Fix/Workaround

Before going to sleep modes where RCSYS is stopped, make sure the division factor between CPU/HSB and PBx frequencies is less than or equal to 4.

Disabling POR33 may generate spurious resets

Depending on operating conditions, POR33 may generate a spurious reset in one of the following cases:

- When POR33 is disabled from the user interface
- When SM33 supply monitor is enabled
- When entering Shutdown mode while debugging the chip using JTAG or aWire interface

In the listed cases, writing a one to the bit VREGCR.POR33MASK in the System Control Interface (SCIF) to mask the POR33 reset will be ineffective

Fix/Workaround

- Do not disable POR33 using the user interface
- Do not use the SM33 supply monitor
- Do not enter Shutdown mode if a debugger is connected to the chip

Instability when exiting sleep walking

If all the following operating conditions are true, exiting sleep walking might lead to instability:

- The OSC0 is enabled in external clock mode (OSCCTRL0.OSCEN == 1 and OSCCTRL0.MODE == 0)
- A sleep mode where the OSC0 is automatically disabled is entered
- The device enters sleep walking

Fix/Workaround

Do not run OSC0 in external clock mode if sleepwalking is expected to be used.

Sleepwalking in idle and frozen sleep mode will mask all other PB clocks

If the CPU is in idle or frozen sleep mode and a module is in a state that triggers sleep walking, all PB clocks will be masked except the PB clock to the sleepwalking module.

Fix/Workaround

Mask all clock requests in the PM.PPCR register before going into idle or frozen mode.

VERSION register reads 0x400

The VERSION register reads 0x400 instead of 0x411.

Fix/Workaround

None.

10.4.7 SCIF

The DFLL should be slowed down before disabling it

The frequency of the DFLL should be set to minimum before disabling it.

Fix/Workaround

Before disabling the DFLL the value of the COARSE register should be zero.

Writing to ICR masks new interrupts received in the same clock cycle



Writing to ICR masks any new SCIF interrupt received in the same clock cycle, regardless of write value.

Fix/Workaround

For every interrupt except BODDET, SM33DET, and VREGOK the PCLKSR register can be read to detect new interrupts. BODDET, SM33DET and VREGOK interrupts will not be generated if they occur whilst writing to the ICR register.

FINE value for DFLL is not correct when dithering is disabled

In open loop mode, the FINE value used by the DFLL DAC is offset by two compared to the value written to the DFLL0CONF.FINE field. The value used by the DFLL DAC is DFLL0CONF.FINE-0x002. If DFLL0CONF.FINE is written to 0x000, 0x001 or 0x002 the value used by the DFLL DAC will be 0x1FE, 0x1FF, or 0x000 respectively.

Fix/Workaround

Write the desired value added by two to the DFLL0CONF.FINE field.

BODVERSION register reads 0x100

The BODVERSION register reads 0x100 instead of 0x101

Fix/Workaround

None.

VREGCR.DEEPMODEDISABLE bit is not readable

VREGCR.DEEPMODEDISABLE bit is not readable.

Fix/Workaround

None.

DFLL step size should be seven or lower when below 30MHz

If max step size is above seven, the DFLL might not lock at the correct frequency if the target frequency is below 30MHz.

Fix/Workaround

If the target frequency is below 30MHz, use a max step size (DFLL0MAXSTEP.MAXSTEP) of seven or lower.

Generic clock sources are kept running in sleep modes

If a clock is used as a source for a generic clock when going to a sleep mode where clock sources are stopped, the source of the generic clock will be kept running. Please refer to Power Manager chapter for details about sleep modes.

Fix/Workaround

Disable generic clocks before going to sleep modes where clock sources are stopped to save power.

DFLL clock is unstable with a fast reference clock

The DFLL clock can be unstable when a fast clock is used as a reference clock in closed loop mode.

Fix/Workaround

Use the 32KHz crystal oscillator clock, or a clock with a similar frequency, as DFLLIF reference clock.

DFLLIF indicates coarse lock too early

The DFLLIF might indicate coarse lock too early, the DFLL will lose coarse lock and regain it later.

Fix/Workaround

Use max step size (DFLL0MAXSTEP.MAXSTEP) of 4 or higher.

DFLLIF dithering does not work



The DFLLIF dithering does not work.

Fix/Workaround

None.

DFLLIF might lose fine lock when dithering is disabled

When dithering is disabled and fine lock has been acquired, the DFLL might lose the fine lock resulting in up to 20% over-/undershoot.

Fix/Workaround

Solution 1: When the DFLL is used as main clock source, the target frequency of the DFLL should be 20% below the maximum operating frequency of the CPU. Don't use the DFLL as clock source for frequency sensitive applications.

Solution 2: Do not use the DFLL in closed loop mode.

GCLK5 is non-functional

GCLK5 is non-functional.

Fix/Workaround

None.

PCLKSR.OSC32RDY bit might not be cleared after disabling OSC32K

In some cases the OSC32RDY bit in the PCLKSR register will not be cleared when OSC32K is disabled.

Fix/Workaround

When re-enabling the OSC32K, read the PCLKSR.OSC32RDY bit. If this bit is:

0: Follow normal procedures.

1: Ignore the PCLKSR.OSC32RDY and ISR.OSC32RDY bit. Use the Frequency Meter (FREQM) to determine if the OSC32K clock is ready. The OSC32K clock is ready when the FREQM measures a non-zero frequency.

BRIFA is non-functional

BRIFA is non-functional.

Fix/Workaround

None.

SCIF VERSION register reads 0x100

SCIFVERSION register reads 0x100 instead of 0x102.

Fix/Workaround

None.

BODVERSION register reads 0x100

BODVERSION register reads 0x100 instead of 0x101.

Fix/Workaround

None.

DFLLVERSION register reads 0x200

DFLLVERSION register reads 0x200 instead of 0x201.

Fix/Workaround

None.

RCCRVERSION register reads 0x100

RCCRVERSION register reads 0x100 instead of 0x101.

Fix/Workaround

None.

OSC32VERSION register reads 0x100

OSC32VERSION register reads 0x100 instead of 0x101.

Fix/Workaround

None.

VREGVERSION register reads 0x100

VREGVERSION register reads 0x100 instead of 0x101.

Fix/Workaround

None.

RC120MVERSION register reads 0x100

RC120MVERSION register reads 0x100 instead of 0x101.

Fix/Workaround

None.

10.4.8 AST

AST wake signal is released one AST clock cycle after the BUSY bit is cleared

After writing to the Status Clear Register (SCR) the wake signal is released one AST clock cycle after the BUSY bit in the Status Register (SR.BUSY) is cleared. If entering sleep mode directly after the BUSY bit is cleared the part will wake up immediately.

Fix/Workaround

Read the Wake Enable Register (WER) and write this value back to the same register. Wait for BUSY to clear before entering sleep mode.

10.4.9 WDT

Clearing the WDT in window mode

In window mode, if the WDT is cleared 2^{TBAN} CLK_WDT cycles after entering the window, the counter will be cleared, but will not exit the window. If this occurs, the SR.WINDOW bit will not be cleared after clearing the WDT.

Fix/Workaround

Check SR.WINDOW immediately after clearing the WDT. If set then clear the WDT once more.

Clearing the Watchdog Timer (WDT) counter in second half of timeout period will issue a Watchdog reset

If the WDT counter is cleared in the second half of the timeout period, the WDT will immediately issue a Watchdog reset.

Fix/Workaround

Use twice as long timeout period as needed and clear the WDT counter within the first half of the timeout period. If the WDT counter is cleared after the first half of the timeout period, you will get a Watchdog reset immediately. If the WDT counter is not cleared at all, the time before the reset will be twice as long as needed.

VERSION register reads 0x400

The VERSION register reads 0x400 instead of 0x402.

Fix/Workaround

None.

10.4.10 FREQM

Measured clock (CLK_MSR) sources 15-17 are shifted

CLKSEL = 14 selects the RC120M AW clock, CLKSEL = 15 selects the RC120M clock, and CLKSEL = 16 selects the RC32K clock as source for the measured clock (CLK_MSR).

Fix/Workaround

None.

GCLK5 can not be used as source for the CLK_MSR

The frequency for GCLK5 can not be measured by the FREQM.

Fix/Workaround

None.

10.4.11 GPIO**GPIO interrupt can not be cleared when interrupts are disabled**

The GPIO interrupt can not be cleared unless the interrupt is enabled for the pin.

Fix/Workaround

Enable interrupt for the corresponding pin, then clear the interrupt.

VERSION register reads 0x210

The VERSION register reads 0x210 instead of 0x211.

Fix/Workaround

None.

10.4.12 USART**The RTS output does not function correctly in hardware handshaking mode**

The RTS signal is not generated properly when the USART receives data in hardware handshaking mode. When the Peripheral DMA receive buffer becomes full, the RTS output should go high, but it will stay low.

Fix/Workaround

Do not use the hardware handshaking mode of the USART. If it is necessary to drive the RTS output high when the Peripheral DMA receive buffer becomes full, use the normal mode of the USART. Configure the Peripheral DMA Controller to signal an interrupt when the receive buffer is full. In the interrupt handler code, write a one to the RTSDIS bit in the USART Control Register (CR). This will drive the RTS output high. After the next DMA transfer is started and a receive buffer is available, write a one to the RTSEN bit in the USART CR so that RTS will be driven low.

10.4.13 SPI**SPI data transfer hangs with CSR0.CSAAT==1 and MR.MODFDIS==0**

When CSR0.CSAAT==1 and mode fault detection is enabled (MR.MODFDIS==0), the SPI module will not start a data transfer.

Fix/Workaround

Disable mode fault detection by writing a one to MR.MODFDIS.

Disabling SPI has no effect on the SR.TDRE bit

Disabling SPI has no effect on the SR.TDRE bit whereas the write data command is filtered when SPI is disabled. Writing to TDR when SPI is disabled will not clear SR.TDRE. If SPI is disabled during a PDCA transfer, the PDCA will continue to write data to TDR until its buffer is empty, and this data will be lost.

Fix/Workaround

Disable the PDCA, add two NOPs, and disable the SPI. To continue the transfer, enable the SPI and PDCA.

SPI disable does not work in SLAVE mode

SPI disable does not work in SLAVE mode.



Fix/Workaround

Read the last received data, then perform a software reset by writing a one to the Software Reset bit in the Control Register (CR.SWRST).

SPI bad serial clock generation on 2nd chip_select when SCBR=1, CPOL=1, and NCPHA=0

When multiple chip selects (CS) are in use, if one of the baudrates equal 1 while one (CSRn.SCBR=1) of the others do not equal 1, and CSRn.CPOL=1 and CSRn.NCPHA=0, then an additional pulse will be generated on SCK.

Fix/Workaround

When multiple CS are in use, if one of the baudrates equals 1, the others must also equal 1 if CSRn.CPOL=1 and CSRn.NCPHA=0.

SPI mode fault detection enable causes incorrect behavior

When mode fault detection is enabled (MR.MODFDIS==0), the SPI module may not operate properly.

Fix/Workaround

Always disable mode fault detection before using the SPI by writing a one to MR.MODFDIS.

SPI RDR.PCS is not correct

The PCS (Peripheral Chip Select) field in the SPI RDR (Receive Data Register) does not correctly indicate the value on the NPCS pins at the end of a transfer.

Fix/Workaround

Do not use the PCS field of the SPI RDR.

10.4.14 TWI**TWI pins are not SMBus compliant**

The TWI pins draw current when they are supplied with 3.3V and the part is left unpowered.

Fix/Workaround

None.

PA21, PB04, and PB05 are not 5V tolerant

Pins PA21, PB04, and PB05 are only 3.3V tolerant.

Fix/Workaround

None.

PB04 SMBALERT function should not be used

The SMBALERT function from TWIMS0 should not be selected on pin PB04.

Fix/Workaround

None.

TWIM STOP bit in IMR always reads as zero

The STOP bit in IMR always reads as zero.

Fix/Workaround

None.

Disabled TWIM drives TWD and TWCK low

When the TWIM is disabled, it drives the TWD and TWCK signals with logic level zero. This can lead to communication problems with other devices on the TWI bus.

Fix/Workaround

Enable the TWIM first and then enable the TWD and TWCK peripheral pins in the GPIO controller. If it is necessary to disable the TWIM, first disable the TWD and TWCK peripheral pins in the GPIO controller and then disable the TWIM.

TWIM SR.IDLE goes high immediately when NAK is received

When a NAK is received and there is a non-zero number of bytes to be transmitted, SR.IDLE goes high immediately and does not wait for the STOP condition to be sent. This does not cause any problem just by itself, but can cause a problem if software waits for SR.IDLE to go high and then immediately disables the TWIM by writing a one to CR.MDIS. Disabling the TWIM causes the TWCK and TWD pins to go high immediately, so the STOP condition will not be transmitted correctly.

Fix/Workaround

If possible, do not disable the TWIM. If it is absolutely necessary to disable the TWIM, there must be a software delay of at least two TWCK periods between the detection of SR.IDLE==1 and the disabling of the TWIM.

TWIM TWALM polarity is wrong

The TWALM signal in the TWIM is active high instead of active low.

Fix/Workaround

Use an external inverter to invert the signal going into the TWIM. When using both TWIM and TWIS on the same pins, the TWALM cannot be used.

TWIS CR.STREN does not work in deep sleep modes

When the device is in Stop, DeepStop, or Static mode, address reception will not wake device if both CR.SOAM and CR.STREN are one.

Fix/Workaround

Do not write both CR.STREN and CR.SOAM to one if the device needs to wake from deep sleep modes.

TWI0.TWCK on PB05 is non-functional

TWI0.TWCK on PB05 is non-functional.

Fix/Workaround

Use TWI0.TWCK on other pins.

TWIM Version Register reads zero

TWIM Version Register (VR) reads zero instead of 0x101

Fix/Workaround

None.

TWIS Version Register reads zero

TWIS Version Register (VR) reads zero instead of 0x112

Fix/Workaround

None.

10.4.15 PWMA

PARAMETER register reads 0x2424

The PARAMETER register reads 0x2424 instead of 0x24.

Fix/Workaround

None.

Writing to the duty cycle registers when the timebase counter overflows can give an undefined result

The duty cycle registers will be corrupted if written when the timebase counter overflows. If the duty cycle registers are written exactly when the timebase counter overflows at TOP, the duty cycle registers may become corrupted.

Fix/Workaround

Write to the duty cycle registers only directly after the Timebase Overflow bit in the status register is set.

Open Drain mode does not work

The open drain mode does not work.

Fix/Workaround

None.

BUSY bit is never cleared after writes to the Control Register (CR)

When writing a non-zero value to CR.TOP, CR.SPREAD, or CR.TCLR when the PWMA is disabled (CR.EN == 0), the BUSY bit in the Status Register (SR.BUSY) will be set, but never cleared.

Fix/Workaround

When writing a non-zero value to CR.TOP, CR.SPREAD, or CR.TCLR, make sure the PWMA is enabled, or simultaneously enable the PWMA by writing a one to CR.EN.

Incoming peripheral events are discarded during duty cycle register update

Incoming peripheral events to all applied channels will be discarded if a duty cycle update is received from the user interface in the same PWMA clock period.

Fix/Workaround

Ensure that duty cycle writes from the user interface are not performed in a PWMA period when an incoming peripheral event is expected.

VERSION register reads 0x100

The VERSION register reads 0x100 instead of 0x101.

Fix/Workaround

None.

10.4.16 TC

When the main clock is RCSYS, TIMER_CLOCK5 is equal to CLK_PBA

When the main clock is generated from RCSYS, TIMER_CLOCK5 is equal to CLK_PBA and not CLK_PBA/128.

Fix/Workaround

None.

10.4.17 ADCIFB

Pendetect in sleep modes without CLK_ADCIFB will not wake the system

The pendetect will not wake the system from a sleep mode if the clock for the ADCIFB (CLK_ADCIFB) is turned off.

Fix/Workaround

Use a sleep mode where CLK_ADCIFB is not turned off to wake the part using pendetect.

8-bit mode is not working

Do not use the ADCIFB 8-bit mode.

Fix/Workaround

Use the 10-bit mode and shift right by two bits.

Using STARTUPTIME larger than 0x1F will freeze the ADC

Writing a value larger than 0x1F to the Startup Time field in the ADC Configuration Register (ACR.STARTUP) will freeze the ADC, and the Busy Status bit in the Status Register (SR.BUSY) will never be cleared.

Fix/Workaround

Do not write values larger than 0x1F to ACR.STARTUP.

ADC channels six to eight are non-functional

ADC channels six to eight are non-functional.

Fix/Workaround

None.

VERSION register reads 0x100

The VERSION register reads 0x100 instead of 0x101.

Fix/Workaround

None.

10.4.18 ACIFB

Generic clock sources in sleep modes.

The ACIFB should not use RC32K or CLK_1K as generic clock source if the chip uses sleep modes.

Fix/Workaround

None.

Negative offset

The static offset of the analog comparator is approximately -50mV

Fix/Workaround

None.

CONFW.WEVSRC and CONFW.WEVEN are not correctly described in the user interface

CONFW.WEVSRC is only two bits instead of three bits wide. Only values 0, 1, and 2 can be written to this register. CONFW.WEVEN is in bit position 10 instead of 11.

Fix/Workaround

Only write values 0, 1, and 2 to CONFW.WEVSRC. When reading CONFW.WEVSRC, disregard the third bit. Read/write bit 10 to access CONFW.WEVEN.

VERSION register reads 0x200

The VERSION register reads 0x200 instead of 0x212.

Fix/Workaround

None.

10.4.19 CAT

Switch off discharge current when reaching 0V

The discharge current will switch off when reaching MGCFG1.MAX, not when reaching 0V.

Fix/Workaround

None.

CAT external capacitors are not clamped to ground when CAT is idle

The CAT module does not clamp the external capacitors to ground when it is idle. The capacitors are left floating, so they could accumulate small amounts of charge.

Fix/Workaround

None.

DISHIFT field is stuck at zero

The DISHIFT field in the MGCFG1, TGACFG1, TGBCFG1, and ATCFG1 registers is stuck at zero and cannot be written to a different value. Capacitor discharge time will only be determined by the DILEN field.

Fix/Workaround

None.

MGCFG2.CONSEN field is stuck at zero

The CONSEN field in the MGCFG2 register is stuck at zero and cannot be written to a different value. The CAT consensus filter does not function properly, so termination of QMatrix data acquisition is controlled only by the MAX field in MGCFG1.

Fix/Workaround

None.

MGCFG2.ACCTRL bit is stuck at zero

The ACCTRL bit in the MGCFG2 register is stuck at zero and cannot be written to one. The analog comparators will be constantly enabled.

Fix/Workaround

None.

CAT asynchronous wake will be delayed by one AST event period

If the CAT detects a condition the should asynchronously wake the device in static mode, the asynchronous wake will not occur until the next AST event. For example, if the AST is generating events to the CAT every 50ms, and the CAT detects a touch at t=9200ms, the asynchronous wake will occur at t=9250ms.

Fix/Workaround

None.

VERSION register reads 0x100

The VERSION register reads 0x100 instead of 0x200.

Fix/Workaround

None.

10.4.20 GLOC**GLOC is non-functional**

Glue Logic Controller (GLOC) is non-functional.

Fix/Workaround

None.

10.4.21 aWire**SAB multiaccess reads are not working**

Reading more than one word, halfword, or byte in one command is not working correctly.

Fix/Workaround

Split the access into several single word, halfword, or byte accesses.

If a reset happens during the last SAB write, the aWire will stall

If a reset happens during the last word, halfword or byte write the aWire will wait forever for an acknowledge from the SAB.

Fix/Workaround

Reset the aWire by keeping the RESET_N line low for 100ms.

aWire enable does not work in Static mode

aWire enable does not work in Static mode.

Fix/Workaround

None.

aWire CPU clock speed robustness

The aWire memory speed request command counter warps at clock speeds below approximately 5kHz.

Fix/Workaround

None.

The aWire debug interface is reset after leaving Shutdown mode

If the aWire debug mode is used as debug interface and the program enters Shutdown mode, the aWire interface will be reset when the part receives a wakeup either from the WAKE_N pin or the AST.

Fix/Workaround

None.

aWire PB mapping and PB clock mask number

The aWire PB has a different PB address and PB clock mask number.

Fix/Workaround

Use aWire PB address 0xFFFF6C00 and PB clock (PBAMASK) 24.

VERSION register reads 0x200

The VERSION register reads 0x200 instead of 0x210.

Fix/Workaround

None.

10.4.22 Chip

WAKE_N pin can only wake up the chip from Shutdown mode

It is not possible to wake up the chip from any other sleep mode than Shutdown using the WAKE_N pin. If the WAKE_N pin is asserted during a sleep mode other than Shutdown, nothing will happen.

Fix/Workaround

Use an EIC pin to wake up from sleep modes higher than Shutdown.

Power consumption in static mode is too high

Power consumption in static mode is too high when PA21 is high.

Fix/Workaround

Ensure PA21 is low.

Shutdown mode is not functional

Do not enter Shutdown mode.

Fix/Workaround

None.

VDDIN current consumption increase above 1.8V

When VDDIN increases above 1.8V, current on VDDIN increases with up to 40uA.

Fix/Workaround

None.

Increased Power Consumption in VDDIO in sleep modes

If OSC0 is enabled in crystal mode when entering a sleep mode where the OSC0 is disabled, this will lead to an increased power consumption in VDDIO.

Fix/Workaround

Solution 1: Disable OSC0 by writing a zero to the Oscillator Enable bit in the System Control Interface (SCIF) Oscillator Control Register (SCIF.OSC0CTRL.OSCEN) before going to a sleep mode where OSC0 is disabled.

Solution 2: Pull down or up XIN0 and XOUT0 with 1 MOhm resistor.

10.4.23 I/O Pins**PB10 is not 3.3V tolerant.**

PB10 should be grounded on the PCB and left unused.

Fix/Workaround

None.

Analog multiplexing consumes extra power

Current consumption on VDDIO increases when the voltage on analog inputs is close to VDDIO/2.

Fix/Workaround

None.

PA02, PB01, PB04, PB05, and RESET_N have half of the pull-up strength

Pins PA02, PB01, PB04, PB05, and RESET_N have half of the specified pull-up strength.

Fix/Workaround

None.

JTAG is enabled at power up

The JTAG function on pins PA00, PA01, PA02, and PA03, are enabled after startup. Normal I/O module functionality is not possible on these pins.

Fix/Workaround

Add a 10kOhm pullup on the reset line.

MCKO and MDO[3] are swapped in the AUX1 mapping

When using the OCD AUX1 mapping of trace signals MDO[3] is located on pin PB05 and MCKO is located on PB01.

Fix/Workaround

Swap pins PB01 and PB05 if using OCD AUX1.

10.5

11. Datasheet Revision History

Please note that the referring page numbers in this section are referred to this document. The referring revision in this section are referring to the document revision.

11.1 Rev. G - 06/2011

1. FLASHCDW: FSR register is a Read-only register. Added info about QPRUP
2. PM: Clarified POR33 masking requirements before shutdown. Added more info about wakeup sources. Added AWEN description. PPCR register reset value corrected.
3. SAU: SR.IDLE definition and reset value corrected.
4. DFLL: Open- and closed-loop operation clarified.
5. OSC32: Added note about OSC32RDY bit not always cleared when disabling OSC32.
6. USART: Major cleanup.

11.2 Rev. F- 11/2010

1. Features: Removed superfluous R mark.
2. Package and Pinout, GPIO function multiplexing: TWIMS0-TWCK on PA20 removed. ADCIFB-AD[3] on PA17 removed, number of ADC channels are 8, not 9. These were removed from rev. C, but reappeared in rev. E.

11.3 Rev. E- 10/2010

1. Overview: Added missing signals in block diagram.
2. Package and pinout: Added note about TWI, SMBUS and 5V tolerant pads in peripheral multiplexing. Added CAT DIS signal to signal descriptions. Removed TBD on ADVREFFP minimum voltage.
3. Memories: Added SAU slave address to physical memory map.
4. Supply and startup considerations: VDDIN is using GND as ground pin. Clarified references to PORs in startup considerations.
5. FLASHCDW: Added serial number location to module configuration section.
6. PM: Added more info about the WAKE_N pin. Added info about CLK_PM, Updated the selection main clock source section.
7. SCIF: Major chapter update.
8. AST: Updated digital tuner formula and conditions.
9. GPIO: Updated GPER reset value and added more registers with non-zero reset value.
10. CAT: Added info about VDIVEN and discharge current formula.
11. ADCIFB: Fixed Sample and Hold time formula.
12. GLOC: Added info about pullup control and renamed LUTCR register to CR.

13. TC: Added features and version register.
14. SAU: Added OPEN bit to config register. Added description of unlock fields.
15. TWIS: SCR is Write-only. Improved explanation of slave transmitter mode. Updated data transfer diagrams.
16. Electrical Characteristics: Added more values. Added notes on simulated and characterized values. Added pin capacitance, rise, and fall times. Added timing characteristics. Removed all TBDs. Added ADC analog input characteristics. Symbol cleanup.
17. Errata: Updated errata list.

11.4 Rev. D - 06/2010

1. Ordering Information: Ordering code for TQFP ES changed from AT32UC3L064-AUES to AT32UC3L064-AUTES. TLLGA48 Tray option added.

11.5 Rev. C - 06/2010

1. Features and Description: Added QTouch library support.
2. USART: Description of unimplemented features removed.
3. Electrical Characteristics: Power Consumption numbers updated. Flash timing numbers added.

11.6 Rev. B - 05/2010

1. Package and Pinout: Added pinout figure for TLLGA48 package.
2. Package and Pinout, GPIO function multiplexing: TWIMS0-TWCK on PA20 removed. ADCIFB-AD[3] on PA17 removed, number of ADC channels are 8, not 9.
3. I/O Lines Considerations: Added: Following pins have high-drive capability: PA02, PA06, PA08, PA09, and PB01.
Some TWI0 pins are SMBUS compliant (PA21, PB04, PB05).
4. HMATRIX Masters: PDCA is master 4, not master 3. SAU is master 3, not master 4.
5. SAU: IDLE bit added in the Status Register.
6. PDCA: Number of PDCA performance monitors is device dependent.
7. Peripheral Event System: Chapter updated.
8. PM: Bits in RCAUSE registers removed and renamed (JTAGHARD and AWIREHARD renamed to JTAG and AWIRE respectively, JTAG and AWIRE removed. BOD33 bit removed).
9. PM: RCAUSE.BOD33 bit removed. SM33 reset will be detected as a POR reset.
10. PM: WDT can be used as wake-up source if WDT is clocked from 32KHz oscillator.
11. PM: Entering Shutdown mode description updated.
12. SCIF: DFLL output frequency is 40-150MHz, not 20-150MHz or 30-150MHz.

13. SCIF: Temperature sensor is connected to ADC channel 9, not 7.
14. SCIF: Updated the oscillator connection figure for OSC0
15. GPIO: Removed unimplemented features (pull-down, buskeeper, drive strength, slew rate, Schmidt trigger, open drain).
16. SPI: RDR.PCS field removed (RDR[19:16]).
17. TWIS: Figures updated.
18. ADCIFB: The sample and hold time and the startup time formulas have been corrected (ADC Configuration Register).
19. ADCIFB: Updated ADC signal names.
20. ACIFB: CONFW.WEVSRC is bit 8-10, CONFW.EWEVEN is bit 11. CONF.EVENP and CONF.EVENN bits are swapped.
21. CAT: Matrix size is 16 by 8, not 18 by 8.
22. Electrical Characteristics: General update.
23. Mechanical Characteristics: Added numbers for package drawings.
24. Mechanical Characteristics: In the TQFP-48 package drawing the Lead Coplanarity is 0.102mm, not 0.080mm.
25. Ordering Information: Ordering code for TLLGA-48 package updated.

11.7 Rev. A – 06/2009

1. Initial revision.

Table of Contents

	Features	1
1	Description	3
2	Overview	5
	2.1 Block Diagram	5
	2.2 Configuration Summary	6
3	Package and Pinout	7
	3.1 Package	7
	3.2 Peripheral Multiplexing on I/O lines	9
	3.3 Signal Descriptions	13
	3.4 I/O Line Considerations	16
4	Processor and Architecture	18
	4.1 Features	18
	4.2 AVR32 Architecture	18
	4.3 The AVR32UC CPU	19
	4.4 Programming Model	23
	4.5 Exceptions and Interrupts	27
5	Memories	32
	5.1 Embedded Memories	32
	5.2 Physical Memory Map	32
	5.3 Peripheral Address Map	33
	5.4 CPU Local Bus Mapping	34
6	Supply and Startup Considerations	36
	6.1 Supply Considerations	36
	6.2 Startup Considerations	40
7	Electrical Characteristics	41
	7.1 Disclaimer	41
	7.2 Absolute Maximum Ratings*	41
	7.3 Supply Characteristics	41
	7.4 Maximum Clock Frequencies	42
	7.5 Power Consumption	42
	7.6 I/O Pin Characteristics	47
	7.7 Oscillator Characteristics	50

7.8 Flash Characteristics54

7.9 Analog Characteristics55

7.10 Timing Characteristics63

8 Mechanical Characteristics 73

8.1 Thermal Considerations73

8.2 Package Drawings74

8.3 Soldering Profile77

9 Ordering Information 78

10 Errata 79

10.1 Rev. E79

10.2 Rev. D84

10.3 Rev. C90

10.4 Rev. B90

10.5104

11 Datasheet Revision History 105

11.1 Rev. G - 06/2011105

11.2 Rev. F- 11/2010105

11.3 Rev. E- 10/2010105

11.4 Rev. D - 06/2010106

11.5 Rev. C - 06/2010106

11.6 Rev. B - 05/2010106

11.7 Rev. A – 06/2009107

Table of Contents..... i





Headquarters

Atmel Corporation
2325 Orchard Parkway
San Jose, CA 95131
USA
Tel: 1(408) 441-0311
Fax: 1(408) 487-2600

International

Atmel Asia
Unit 1-5 & 16, 19/F
BEA Tower, Millennium City 5
418 Kwun Tong Road
Kwun Tong, Kowloon
Hong Kong
Tel: (852) 2245-6100
Fax: (852) 2722-1369

Atmel Europe
Le Krebs
8, Rue Jean-Pierre Timbaud
BP 309
78054 Saint-Quentin-en-
Yvelines Cedex
France
Tel: (33) 1-30-60-70-00
Fax: (33) 1-30-60-71-11

Atmel Japan
9F, Tonetsu Shinkawa Bldg.
1-24-8 Shinkawa
Chuo-ku, Tokyo 104-0033
Japan
Tel: (81) 3-3523-3551
Fax: (81) 3-3523-7581

Product Contact

Web Site
www.atmel.com

Technical Support
avr32@atmel.com

Sales Contact
www.atmel.com/contacts

Literature Requests
www.atmel.com/literature

Disclaimer: The information in this document is provided in connection with Atmel products. No license, express or implied, by estoppel or otherwise, to any intellectual property right is granted by this document or in connection with the sale of Atmel products. **EXCEPT AS SET FORTH IN ATMEL'S TERMS AND CONDITIONS OF SALE LOCATED ON ATMEL'S WEB SITE, ATMEL ASSUMES NO LIABILITY WHATSOEVER AND DISCLAIMS ANY EXPRESS, IMPLIED OR STATUTORY WARRANTY RELATING TO ITS PRODUCTS INCLUDING, BUT NOT LIMITED TO, THE IMPLIED WARRANTY OF MERCHANTABILITY, FITNESS FOR A PARTICULAR PURPOSE, OR NON-INFRINGEMENT. IN NO EVENT SHALL ATMEL BE LIABLE FOR ANY DIRECT, INDIRECT, CONSEQUENTIAL, PUNITIVE, SPECIAL OR INCIDENTAL DAMAGES (INCLUDING, WITHOUT LIMITATION, DAMAGES FOR LOSS OF PROFITS, BUSINESS INTERRUPTION, OR LOSS OF INFORMATION) ARISING OUT OF THE USE OR INABILITY TO USE THIS DOCUMENT, EVEN IF ATMEL HAS BEEN ADVISED OF THE POSSIBILITY OF SUCH DAMAGES.** Atmel makes no representations or warranties with respect to the accuracy or completeness of the contents of this document and reserves the right to make changes to specifications and product descriptions at any time without notice. Atmel does not make any commitment to update the information contained herein. Unless specifically provided otherwise, Atmel products are not suitable for, and shall not be used in, automotive applications. Atmel's products are not intended, authorized, or warranted for use as components in applications intended to support or sustain life.

© 2011 Atmel Corporation. All rights reserved. Atmel®, Atmel logo and combinations thereof, AVR® and others are registered trademarks or trademarks of Atmel Corporation or its subsidiaries. Other terms and product names may be trademarks of others.

Looking for pricing, stock, or lifecycle information?

Click below to explore more details on WIN SOURCE:

- ⊖ [View AT32UC3L0-XPLD on WIN SOURCE](#)
- ⊖ [Microchip Technology](#) Information

Optimize Your Supply Chain with WIN SOURCE Solutions

- ✓ Global Sourcing Solution
- ✓ Obsolete Management
- ✓ Cost Control Management
- ✓ Shortage Management
- ✓ Alternative Solution
- ✓ Excess Inventory Management