

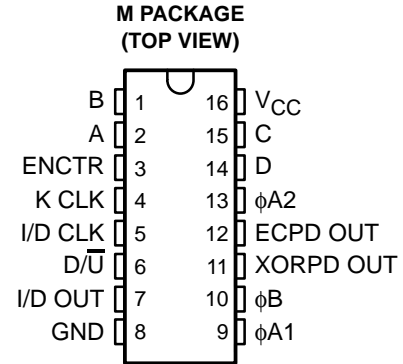

**THE DATASHEET OF  
CD74ACT297M**



- **Speed of Bipolar FCT, AS, and S, With Significantly Reduced Power Consumption**
- **Digital Design Avoids Analog Compensation Errors**
- **Easily Cascadable for Higher-Order Loops**
- **Useful Frequency Range**
  - DC to 110 MHz Typical (K CLK)
  - DC to 70 MHz Typical (I/D CLK)
- **Dynamically Variable Bandwidth**
- **Very Narrow Bandwidth Attainable**
- **Power-On Reset**
- **Output Capability**
  - Standard: XORPD OUT, ECPD OUT
  - Bus Driver: I/D OUT
- **SCR Latch-Up-Resistant CMOS Process and Circuit Design**
- **Balanced Propagation Delays**
- **ESD Protection Exceeds 2000 V Per MIL-STD-883, Method 3015**



### description/ordering information

The CD74ACT297 provides a simple, cost-effective solution to high-accuracy, digital, phase-locked-loop applications. This device contains all the necessary circuits, with the exception of the divide-by-N counter, to build first-order phase-locked loops as shown in Figure 1.

Both exclusive-OR phase detectors (XORPDs) and edge-controlled (ECPD) phase detectors are provided for maximum flexibility.

Proper partitioning of the loop function, with many of the building blocks external to the package, makes it easy for the designer to incorporate ripple cancellation or to cascade to higher-order phase-locked loops.

The length of the up/down K counter is digitally programmable according to the K-counter function table. With A, B, C, and D all low, the K counter is disabled. With A high and B, C, and D low, the K counter is only three stages long, which widens the bandwidth, or capture range, and shortens the lock time of the loop. When A, B, C, and D are programmed high, the K counter becomes 17 stages long, which narrows the bandwidth, or capture range, and lengthens the lock time. Real-time control of loop bandwidth by manipulating the A-through-D inputs can maximize the overall performance of the digital phase-locked loop.

### ORDERING INFORMATION

T <sub>A</sub>	PACKAGE†	ORDERABLE PART NUMBER	TOP-SIDE MARKING
–55°C to 125°C	SOIC – M	Tube	CD74ACT297M
		Tape and reel	CD74ACT297M96
			ACT297M

† Package drawings, standard packing quantities, thermal data, symbolization, and PCB design guidelines are available at [www.ti.com/sc/package](http://www.ti.com/sc/package).



Please be aware that an important notice concerning availability, standard warranty, and use in critical applications of Texas Instruments semiconductor products and disclaimers thereto appears at the end of this data sheet.

# CD74ACT297 DIGITAL PHASE-LOCKED LOOP

SCHS297D – AUGUST 1998 – REVISED JUNE 2002

## description/ordering information (continued)

This device performs the classic first-order phase-locked-loop function without using analog components. The accuracy of the digital phase-locked loop (DPLL) is not affected by  $V_{CC}$  and temperature variations, but depends solely on accuracies of the K clock (K CLK), increment/decrement clock (I/D CLK), and loop propagation delays. The I/D clock frequency and the divide-by-N modulus determine the center frequency of the DPLL. The center frequency is defined by the relationship  $f_c = I/D \text{ clock}/2N$  (Hz).

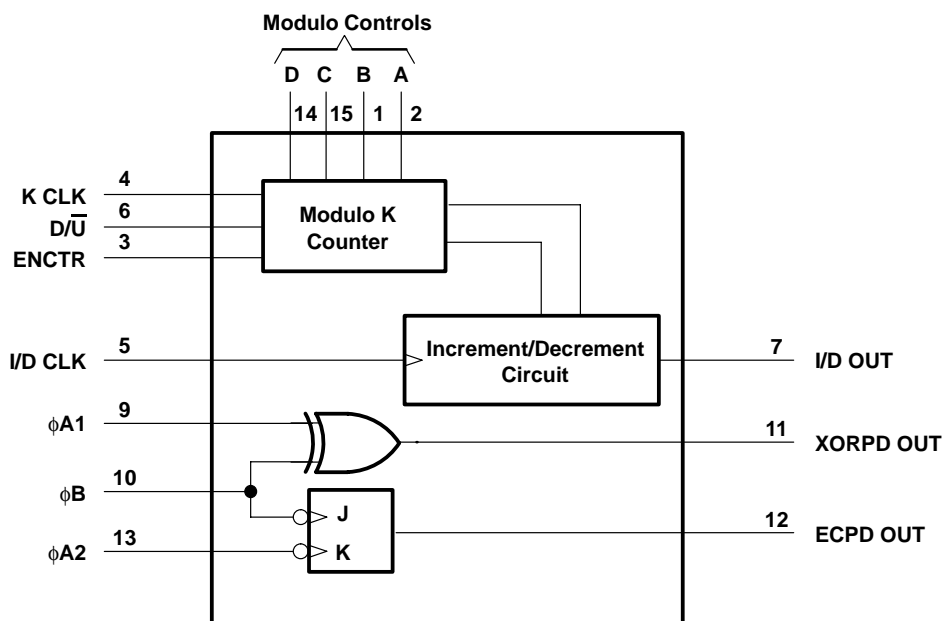

Figure 1. Simplified Block Diagram

**Function Tables**

**K COUNTER**  
(digital control)

D	C	B	A	MODULO (K)
L	L	L	L	Inhibited
L	L	L	H	2 <sup>3</sup>
L	L	H	L	2 <sup>4</sup>
L	L	H	H	2 <sup>5</sup>
L	H	L	L	2 <sup>6</sup>
L	H	L	H	2 <sup>7</sup>
L	H	H	L	2 <sup>8</sup>
L	H	H	H	2 <sup>9</sup>
H	L	L	L	2 <sup>10</sup>
H	L	L	H	2 <sup>11</sup>
H	L	H	L	2 <sup>12</sup>
H	L	H	H	2 <sup>13</sup>
H	H	L	L	2 <sup>14</sup>
H	H	L	H	2 <sup>15</sup>
H	H	H	L	2 <sup>16</sup>
H	H	H	H	2 <sup>17</sup>

**EXCLUSIVE-OR PHASE DETECTOR**

φA1	φB	XORPD OUT
L	L	L
L	H	H
H	L	H
H	H	L

**EDGE-CONTROLLED PHASE DETECTOR**

φA2	φB	ECPD OUT
H or L	↓	H
↓	H or L	L
H or L	↑	No change
↑	H or L	No change

H = steady-state high level  
 L = steady-state low level  
 ↓ = transition from high to low  
 ↑ = transition from low to high

# CD74ACT297 DIGITAL PHASE-LOCKED LOOP

SCHS297D – AUGUST 1998 – REVISED JUNE 2002

## functional block diagram

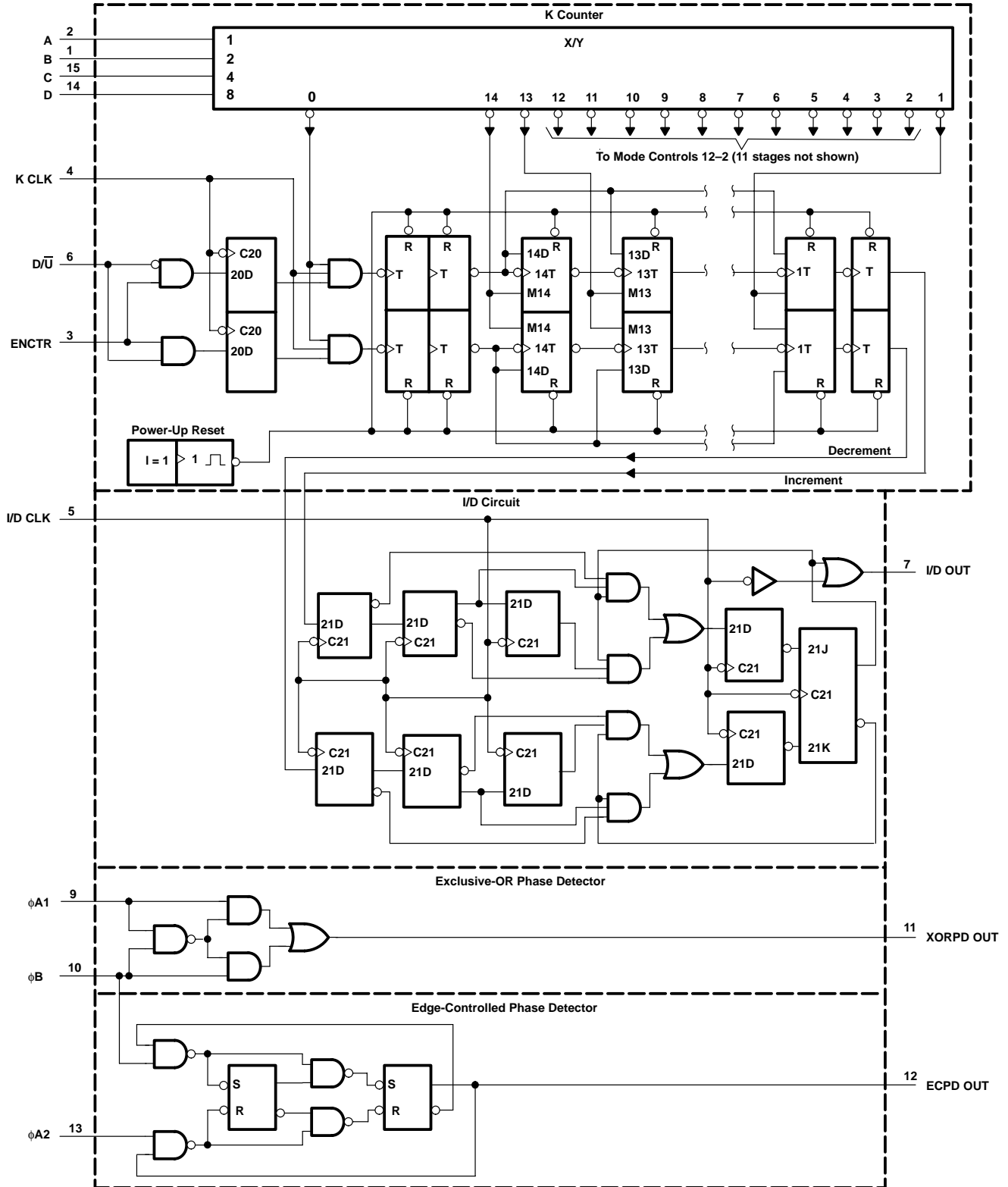

**detailed description**

The phase detector generates an error-signal waveform that, at zero phase error, is a 50% duty-cycle square wave. At the limits of linear operation, the phase-detector output is either high or low all of the time, depending on the direction of the phase error ( $\phi_{in} - \phi_{out}$ ). Within these limits, the phase-detector output varies linearly with the input phase error according to the gain  $k_d$ , which is expressed in terms of phase-detector output per cycle of phase error. The phase-detector output can be varied between  $\pm 1$  according to the relation:

$$\text{Phase-detector output} = \frac{\% \text{ high} - \% \text{ low}}{100} \tag{1}$$

The output of the phase detector is  $k_d \phi_e$ , where the phase error  $\phi_e = \phi_{in} - \phi_{out}$ .

XORPD and ECPD are commonly used digital types. The ECPD is more complex than the XORPD, but can be described generally as a circuit that changes states on one of the transitions of its inputs. For an XORPD,  $k_d = 4$ , because its output remains high (PD output = 1) for a phase error of one-fourth cycle. Similarly, for the ECPD,  $k_d = 2$ , because its output remains high for a phase error of one-half cycle. The type of phase detector determines the zero-phase-error point, i.e., the phase separation of the phase-detector inputs for  $\phi_e$  is defined to be zero. For the basic DPLL system of Figure 2,  $\phi_e = 0$  when the phase-detector output is a square wave. The XORPD inputs are one-fourth cycle out of phase for zero phase error. For the ECPD,  $\phi_e = 0$  when the inputs are one-half cycle out of phase.

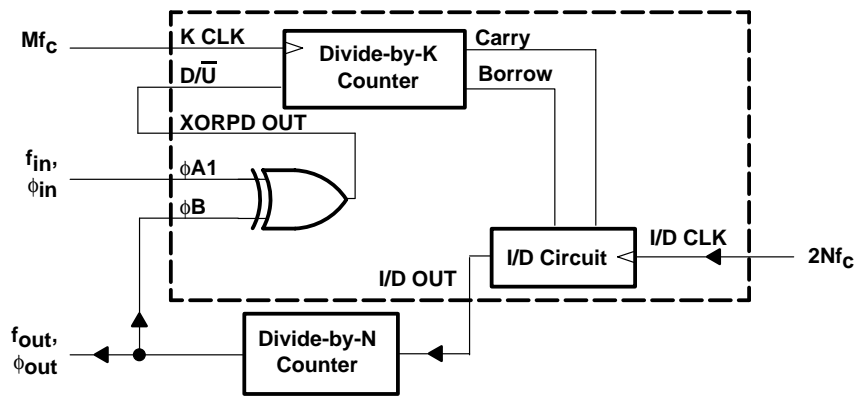

**Figure 2. DPLL Using Exclusive-OR Phase Detection**

The phase-detector output controls the up/down input to the K counter. The counter is clocked by input frequency  $Mf_c$ , which is a multiple M of the loop center frequency  $f_c$ . When the K counter recycles up, it generates a carry pulse. Recycling while counting down generates a borrow pulse. If the carry and borrow outputs are conceptually combined into one output that is positive for a carry and negative for a borrow, and if the K counter is considered as a frequency divider with the ratio  $Mf_c/K$ , the output of the K counter equals the input frequency multiplied by the division ratio. Thus, the output from the K counter is  $k_d \phi_e Mf_c / K$ .

The carry and borrow pulses go to the increment/decrement (I/D) circuit, which, in the absence of any carry or borrow pulse, has an output that is one-half of the input clock (I/D CLK). The input clock is just a multiple (2N) of the loop center frequency. In response to a carry or borrow pulse, the I/D circuit either adds or deletes a pulse at I/D OUT. Thus, the output of the I/D circuit is  $Nf_c + (k_d \phi_e Mf_c) / 2K$ .

The output of the N counter (or the output of the phase-locked loop) is:

$$f_o = f_c + (k_d \phi_e Mf_c) / 2KN \tag{2}$$

When this result is compared to the equation for a first-order analog phase-locked loop, the digital equivalent of the gain of the VCO is  $Mf_c / 2KN$ , or  $f_c / K$  for  $M = 2N$ .

# CD74ACT297 DIGITAL PHASE-LOCKED LOOP

SCHS297D – AUGUST 1998 – REVISED JUNE 2002

## detailed description (continued)

Thus, the simple first-order phase-locked loop with an adjustable K counter is the equivalent of an analog phase-locked loop with a programmable VCO gain.

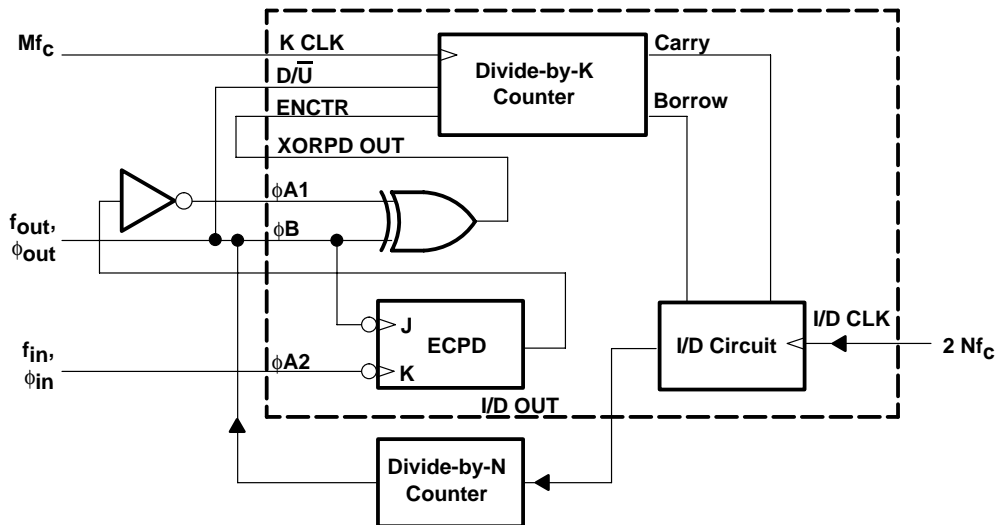

Figure 3. DPLL Using Both Phase Detectors in a Ripple-Cancellation Scheme

## absolute maximum ratings over operating free-air temperature range (unless otherwise noted)†

Supply voltage range, $V_{CC}$	-0.5 V to 6 V
DC input diode current, $I_{IK}$ ( $V_I < -0.5$ V or $V_I > V_{CC} + 0.5$ V)	$\pm 20$ mA
DC input diode current, $I_{OK}$ ( $V_O < -0.5$ V or $V_O > V_{CC} + 0.5$ V)	$\pm 50$ mA
DC output source or sink current per output pin, $I_O$ ( $V_O > -0.5$ V or $V_O < V_{CC} + 0.5$ V)	$\pm 50$ mA
Continuous current through $V_{CC}$ or GND (see Note 1)	$\pm 100$ mA
Package thermal impedance, $\theta_{JA}$ (see Note 2)	73°C/W
Storage temperature range, $T_{stg}$	-65°C to 150°C

† Stresses beyond those listed under “absolute maximum ratings” may cause permanent damage to the device. These are stress ratings only, and functional operation of the device at these or any other conditions beyond those indicated under “recommended operating conditions” is not implied. Exposure to absolute-maximum-rated conditions for extended periods may affect device reliability.

- NOTES: 1. For up to four outputs per device, add  $\pm 25$  mA for each additional output.  
2. The package thermal impedance is calculated in accordance with JESD 51-7.

## recommended operating conditions

	MIN	MAX	UNIT
$V_{CC}$ Supply voltage	4.5	5.5	V
$V_{IH}$ High-level input voltage	2		V
$V_{IL}$ Low-level input voltage		0.8	V
$V_I$ Input voltage	0	$V_{CC}$	V
$V_O$ Output voltage	0	$V_{CC}$	V
$\Delta t/\Delta v$ Input rise and fall slew rate		10	ns
$T_A$ Operating free-air temperature range	-55	125	°C

**electrical characteristics over recommended operating free-air temperature range (unless otherwise noted)**

PARAMETER	TEST CONDITIONS	V <sub>CC</sub>	T <sub>A</sub> = 25°C		MIN	MAX	UNIT
			MIN	MAX			
V <sub>OH</sub>	V <sub>I</sub> = V <sub>IH</sub> or V <sub>IL</sub>	I <sub>O</sub> = -50 μA	4.5 V	4.4	4.4	V	
		I <sub>O</sub> = -24 mA	4.5 V	3.4	3.1		
		I <sub>O</sub> = -75 mA	5.5 V		3.3		
V <sub>OL</sub>	V <sub>I</sub> = V <sub>IH</sub> or V <sub>IL</sub>	I <sub>O</sub> = 50 μA	4.5 V	0.1	0.1	V	
		I <sub>O</sub> = 24 mA	4.5 V	0.9	1.1		
		I <sub>O</sub> = 75 mA <sup>†</sup>	5.5 V		2.9		
I <sub>I</sub>	V <sub>I</sub> = V <sub>CC</sub> or GND	5.5 V	±0.1	±1	μA		
I <sub>CC</sub> (MSI)	V <sub>I</sub> = V <sub>CC</sub> or GND	5.5 V	8	80	μA		
I <sub>CC</sub> (SSI/FF)	V <sub>I</sub> = V <sub>CC</sub> or GND	5.5 V	4	40	μA		
ΔI <sub>CC</sub>	V <sub>I</sub> = V <sub>CC</sub> -2.1 V	4.5 V to 5.5 V	2.4	2.8	mA		

<sup>†</sup> Test one output at a time for a 1-second maximum duration. Measurement is made by forcing current and measuring voltage to minimize power dissipation. Test verifies a minimum 50-Ω transmission-line drive capability at 85°C.

**ACT INPUT LOAD**

INPUT	UNIT LOAD <sup>†</sup>
ENCTR, D/ $\bar{U}$	0.1
A, B, C, D, K CLK, $\phi$ A2	0.2
I/D CLK, $\phi$ A1, $\phi$ B	0.5

<sup>†</sup> Unit Load is ΔI<sub>CC</sub> limit specified in electrical characteristics table (e.g., 2.4 mA at 25°C).

**timing requirements over recommended supply-voltage range and recommended operating free-air temperature range (unless otherwise noted)**

PARAMETER		T <sub>A</sub> = 25°C		MIN	MAX	UNIT
		MIN	MAX			
f <sub>clock</sub>	Clock frequency	K CLK	55	45	MHz	
		I/D CLK	40	35		
t <sub>w</sub>	Pulse duration	K CLK	6	8	ns	
		I/D CLK	7	9		
t <sub>su</sub>	Setup time before K CLK <sup>↑</sup>	D/ $\bar{U}$	13	17	ns	
		ENCTR	12	16		
t <sub>h</sub>	Hold time after K CLK <sup>↑</sup>	D/ $\bar{U}$	3	7	ns	
		ENCTR	2	6		

# CD74ACT297 DIGITAL PHASE-LOCKED LOOP

SCHS297D – AUGUST 1998 – REVISED JUNE 2002

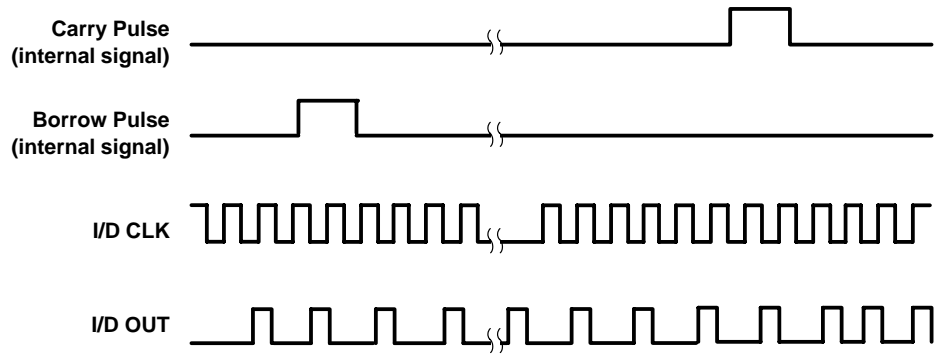

Figure 4. I/D OUT in Lock Condition

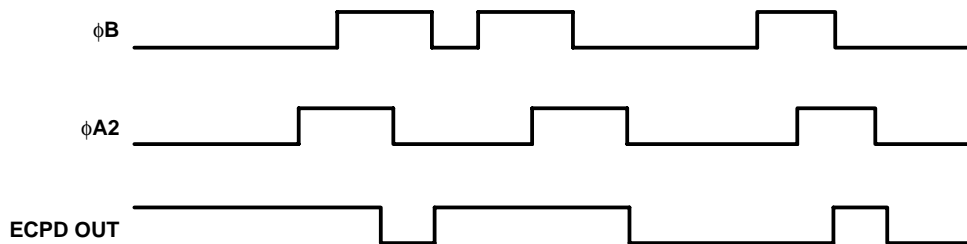

Figure 5. Edge-Controlled Phase-Comparator Waveforms

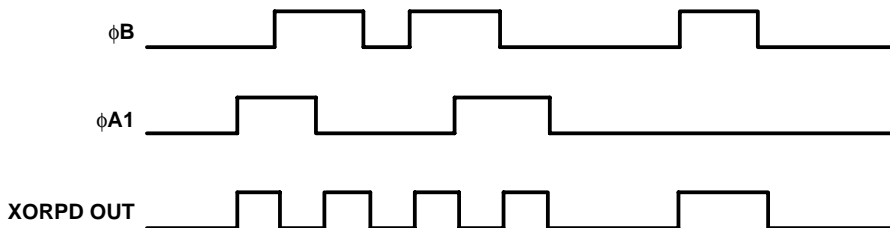

Figure 6. Exclusive-OR Phase-Detector Waveforms

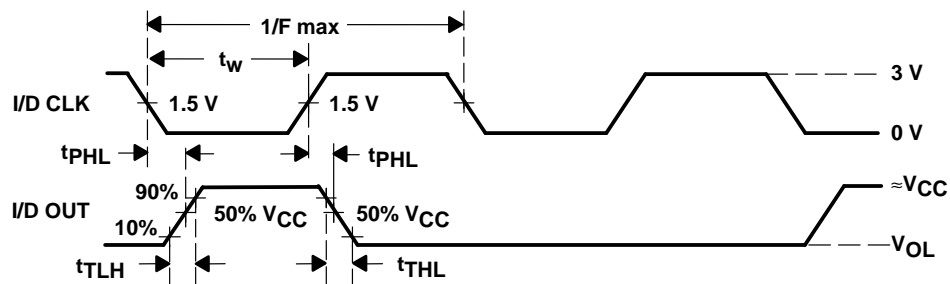

Figure 7. Clock (I/D CLK) to Output (I/D OUT) Propagation Delays, Clock Pulse Duration, and Maximum Clock-Pulse Frequency

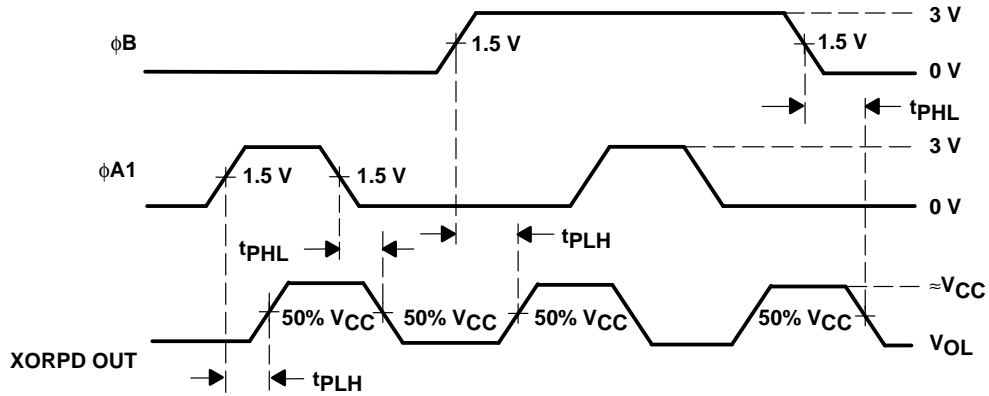

Figure 8. Phase Input ( $\phi B$ ,  $\phi A2$ ) to Output (XORPD OUT) Propagation Delays

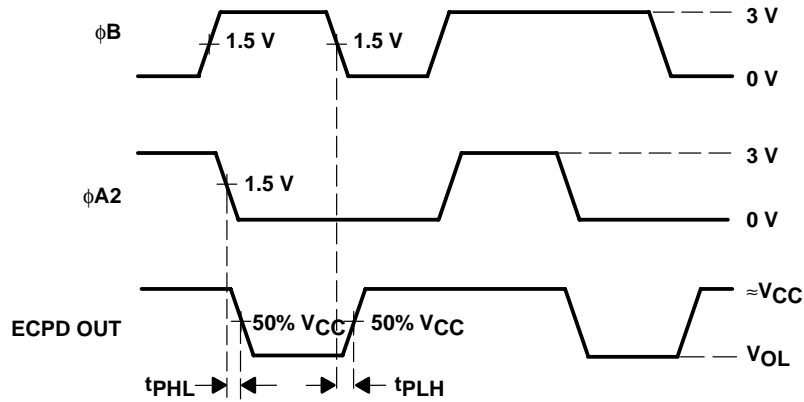
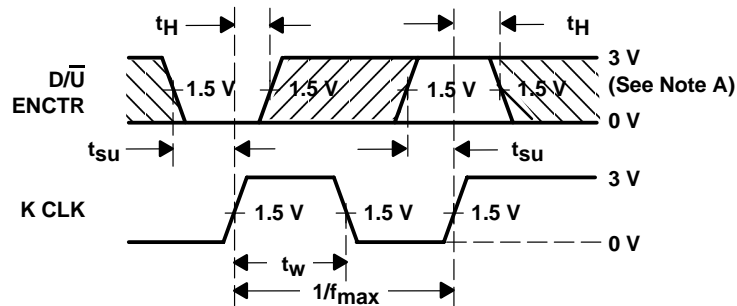

Figure 9. Phase Input ( $\phi B$ ,  $\phi A2$ ) to Output (ECPD OUT) Propagation Delays



NOTE A: Shaded areas indicate when the input is permitted to change for predictable output performance.

Figure 10. Clock (K CLK) Pulse Duration and Maximum Clock-Pulse Frequency, and Inputs ( $D/\bar{U}$ , ENCTR) to Clock (K CLK) Setup and Hold Times

# CD74ACT297

## DIGITAL PHASE-LOCKED LOOP

SCHS297D – AUGUST 1998 – REVISED JUNE 2002

switching characteristics over recommended operating free-air temperature range,  $C_L = 50 \text{ pF}$  (unless otherwise noted)

PARAMETER	FROM (INPUT)	TO (OUTPUT)	$T_A = 25^\circ\text{C}$			MIN	MAX	UNIT
			MIN	TYP	MAX			
$f_{\text{max}}$	K CLK	I/D OUT	55			45	MHz	
	I/D CLK		40			35		
$t_{\text{PLH}}$	I/D CLK	I/D OUT	19			24	ns	
$t_{\text{PHL}}$			19			24		
$t_{\text{PHL}}$	$\phi A2$	ECPD OUT	24			30	ns	
$t_{\text{PLH}}$	$\phi A1$	XORPD OUT	17			22	ns	
$t_{\text{PHL}}$			17			22		
$t_{\text{PLH}}$	$\phi B$	XORPD OUT	17			22	ns	
$t_{\text{PHL}}$			17			22		
$t_{\text{PLH}}$	$\phi B$	ECPD OUT	24			30	ns	

PARAMETER MEASUREMENT INFORMATION

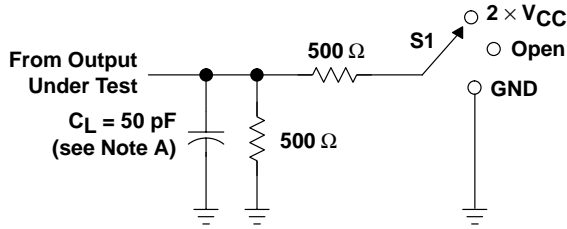

LOAD CIRCUIT

TEST	S1
$t_{PLH}/t_{PHL}$	Open
$t_{PLZ}/t_{PZL}$	$2 \times V_{CC}$
$t_{PHZ}/t_{PZH}$	GND

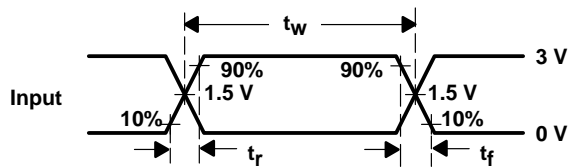

VOLTAGE WAVEFORMS  
INPUT RISE AND FALL TIMES AND PULSE DURATION

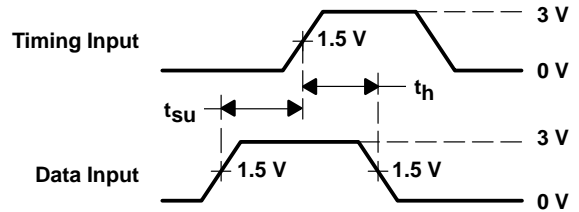

VOLTAGE WAVEFORMS  
SETUP AND HOLD TIMES

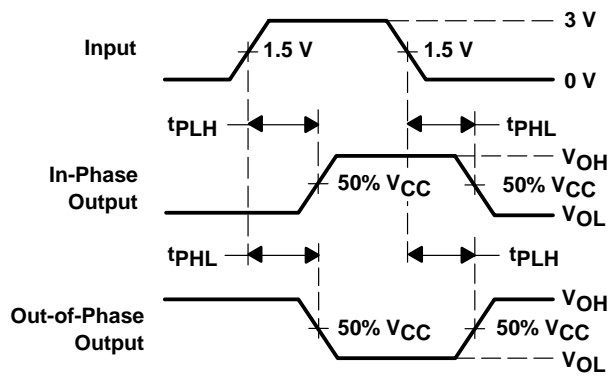

VOLTAGE WAVEFORMS  
PROPAGATION DELAY TIMES

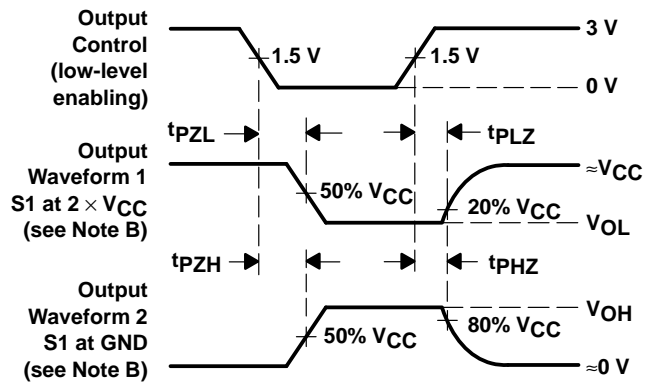

VOLTAGE WAVEFORMS  
ENABLE AND DISABLE TIMES

- NOTES: A.  $C_L$  includes probe and jig capacitance.  
 B. Waveform 1 is for an output with internal conditions such that the output is low except when disabled by the output control. Waveform 2 is for an output with internal conditions such that the output is high except when disabled by the output control.  
 C. All input pulses are supplied by generators having the following characteristics:  $PRR \leq 1 \text{ MHz}$ ,  $Z_O = 50 \Omega$ ,  $t_r = 3 \text{ ns}$ ,  $t_f = 3 \text{ ns}$ .  
 D. The outputs are measured one at a time with one input transition per measurement.

Figure 11. Load Circuit and Voltage Waveforms

**PACKAGING INFORMATION**

Orderable Device	Status (1)	Package Type	Package Drawing	Pins	Package Qty	Eco Plan (2)	Lead/Ball Finish (6)	MSL Peak Temp (3)	Op Temp (°C)	Device Marking (4/5)	Samples
CD74ACT297M	ACTIVE	SOIC	D	16	40	Green (RoHS & no Sb/Br)	CU NIPDAU	Level-1-260C-UNLIM	-55 to 125	ACT297M	<a href="#">Samples</a>
CD74ACT297M96	ACTIVE	SOIC	D	16	2500	Green (RoHS & no Sb/Br)	CU NIPDAU	Level-1-260C-UNLIM	-55 to 125	ACT297M	<a href="#">Samples</a>

(1) The marketing status values are defined as follows:

**ACTIVE:** Product device recommended for new designs.

**LIFEBUY:** TI has announced that the device will be discontinued, and a lifetime-buy period is in effect.

**NRND:** Not recommended for new designs. Device is in production to support existing customers, but TI does not recommend using this part in a new design.

**PREVIEW:** Device has been announced but is not in production. Samples may or may not be available.

**OBsolete:** TI has discontinued the production of the device.

(2) Eco Plan - The planned eco-friendly classification: Pb-Free (RoHS), Pb-Free (RoHS Exempt), or Green (RoHS & no Sb/Br) - please check <http://www.ti.com/productcontent> for the latest availability information and additional product content details.

**TBD:** The Pb-Free/Green conversion plan has not been defined.

**Pb-Free (RoHS):** TI's terms "Lead-Free" or "Pb-Free" mean semiconductor products that are compatible with the current RoHS requirements for all 6 substances, including the requirement that lead not exceed 0.1% by weight in homogeneous materials. Where designed to be soldered at high temperatures, TI Pb-Free products are suitable for use in specified lead-free processes.

**Pb-Free (RoHS Exempt):** This component has a RoHS exemption for either 1) lead-based flip-chip solder bumps used between the die and package, or 2) lead-based die adhesive used between the die and leadframe. The component is otherwise considered Pb-Free (RoHS compatible) as defined above.

**Green (RoHS & no Sb/Br):** TI defines "Green" to mean Pb-Free (RoHS compatible), and free of Bromine (Br) and Antimony (Sb) based flame retardants (Br or Sb do not exceed 0.1% by weight in homogeneous material)

(3) MSL, Peak Temp. - The Moisture Sensitivity Level rating according to the JEDEC industry standard classifications, and peak solder temperature.

(4) There may be additional marking, which relates to the logo, the lot trace code information, or the environmental category on the device.

(5) Multiple Device Markings will be inside parentheses. Only one Device Marking contained in parentheses and separated by a "~" will appear on a device. If a line is indented then it is a continuation of the previous line and the two combined represent the entire Device Marking for that device.

(6) Lead/Ball Finish - Orderable Devices may have multiple material finish options. Finish options are separated by a vertical ruled line. Lead/Ball Finish values may wrap to two lines if the finish value exceeds the maximum column width.

**Important Information and Disclaimer:** The information provided on this page represents TI's knowledge and belief as of the date that it is provided. TI bases its knowledge and belief on information provided by third parties, and makes no representation or warranty as to the accuracy of such information. Efforts are underway to better integrate information from third parties. TI has taken and continues to take reasonable steps to provide representative and accurate information but may not have conducted destructive testing or chemical analysis on incoming materials and chemicals. TI and TI suppliers consider certain information to be proprietary, and thus CAS numbers and other limited information may not be available for release.

In no event shall TI's liability arising out of such information exceed the total purchase price of the TI part(s) at issue in this document sold by TI to Customer on an annual basis.

**TAPE AND REEL INFORMATION**



**QUADRANT ASSIGNMENTS FOR PIN 1 ORIENTATION IN TAPE**



\*All dimensions are nominal

Device	Package Type	Package Drawing	Pins	SPQ	Reel Diameter (mm)	Reel Width W1 (mm)	A0 (mm)	B0 (mm)	K0 (mm)	P1 (mm)	W (mm)	Pin1 Quadrant
CD74ACT297M96	SOIC	D	16	2500	330.0	16.4	6.5	10.3	2.1	8.0	16.0	Q1

**TAPE AND REEL BOX DIMENSIONS**



\*All dimensions are nominal

Device	Package Type	Package Drawing	Pins	SPQ	Length (mm)	Width (mm)	Height (mm)
CD74ACT297M96	SOIC	D	16	2500	333.2	345.9	28.6

D (R-PDSO-G16)

PLASTIC SMALL OUTLINE



- NOTES:
- A. All linear dimensions are in inches (millimeters).
  - B. This drawing is subject to change without notice.
  - C. Body length does not include mold flash, protrusions, or gate burrs. Mold flash, protrusions, or gate burrs shall not exceed 0.006 (0,15) each side.
  - D. Body width does not include interlead flash. Interlead flash shall not exceed 0.017 (0,43) each side.
  - E. Reference JEDEC MS-012 variation AC.

D (R-PDSO-G16)

PLASTIC SMALL OUTLINE



- NOTES:
- All linear dimensions are in millimeters.
  - This drawing is subject to change without notice.
  - Publication IPC-7351 is recommended for alternate designs.
  - Laser cutting apertures with trapezoidal walls and also rounding corners will offer better paste release. Customers should contact their board assembly site for stencil design recommendations. Refer to IPC-7525 for other stencil recommendations.
  - Customers should contact their board fabrication site for solder mask tolerances between and around signal pads.

## IMPORTANT NOTICE

Texas Instruments Incorporated and its subsidiaries (TI) reserve the right to make corrections, enhancements, improvements and other changes to its semiconductor products and services per JESD46, latest issue, and to discontinue any product or service per JESD48, latest issue. Buyers should obtain the latest relevant information before placing orders and should verify that such information is current and complete. All semiconductor products (also referred to herein as "components") are sold subject to TI's terms and conditions of sale supplied at the time of order acknowledgment.

TI warrants performance of its components to the specifications applicable at the time of sale, in accordance with the warranty in TI's terms and conditions of sale of semiconductor products. Testing and other quality control techniques are used to the extent TI deems necessary to support this warranty. Except where mandated by applicable law, testing of all parameters of each component is not necessarily performed.

TI assumes no liability for applications assistance or the design of Buyers' products. Buyers are responsible for their products and applications using TI components. To minimize the risks associated with Buyers' products and applications, Buyers should provide adequate design and operating safeguards.

TI does not warrant or represent that any license, either express or implied, is granted under any patent right, copyright, mask work right, or other intellectual property right relating to any combination, machine, or process in which TI components or services are used. Information published by TI regarding third-party products or services does not constitute a license to use such products or services or a warranty or endorsement thereof. Use of such information may require a license from a third party under the patents or other intellectual property of the third party, or a license from TI under the patents or other intellectual property of TI.

Reproduction of significant portions of TI information in TI data books or data sheets is permissible only if reproduction is without alteration and is accompanied by all associated warranties, conditions, limitations, and notices. TI is not responsible or liable for such altered documentation. Information of third parties may be subject to additional restrictions.

Resale of TI components or services with statements different from or beyond the parameters stated by TI for that component or service voids all express and any implied warranties for the associated TI component or service and is an unfair and deceptive business practice. TI is not responsible or liable for any such statements.

Buyer acknowledges and agrees that it is solely responsible for compliance with all legal, regulatory and safety-related requirements concerning its products, and any use of TI components in its applications, notwithstanding any applications-related information or support that may be provided by TI. Buyer represents and agrees that it has all the necessary expertise to create and implement safeguards which anticipate dangerous consequences of failures, monitor failures and their consequences, lessen the likelihood of failures that might cause harm and take appropriate remedial actions. Buyer will fully indemnify TI and its representatives against any damages arising out of the use of any TI components in safety-critical applications.

In some cases, TI components may be promoted specifically to facilitate safety-related applications. With such components, TI's goal is to help enable customers to design and create their own end-product solutions that meet applicable functional safety standards and requirements. Nonetheless, such components are subject to these terms.

No TI components are authorized for use in FDA Class III (or similar life-critical medical equipment) unless authorized officers of the parties have executed a special agreement specifically governing such use.

Only those TI components which TI has specifically designated as military grade or "enhanced plastic" are designed and intended for use in military/aerospace applications or environments. Buyer acknowledges and agrees that any military or aerospace use of TI components which have **not** been so designated is solely at the Buyer's risk, and that Buyer is solely responsible for compliance with all legal and regulatory requirements in connection with such use.

TI has specifically designated certain components as meeting ISO/TS16949 requirements, mainly for automotive use. In any case of use of non-designated products, TI will not be responsible for any failure to meet ISO/TS16949.

### Products

Audio	<a href="http://www.ti.com/audio">www.ti.com/audio</a>
Amplifiers	<a href="http://amplifier.ti.com">amplifier.ti.com</a>
Data Converters	<a href="http://dataconverter.ti.com">dataconverter.ti.com</a>
DLP® Products	<a href="http://www.dlp.com">www.dlp.com</a>
DSP	<a href="http://dsp.ti.com">dsp.ti.com</a>
Clocks and Timers	<a href="http://www.ti.com/clocks">www.ti.com/clocks</a>
Interface	<a href="http://interface.ti.com">interface.ti.com</a>
Logic	<a href="http://logic.ti.com">logic.ti.com</a>
Power Mgmt	<a href="http://power.ti.com">power.ti.com</a>
Microcontrollers	<a href="http://microcontroller.ti.com">microcontroller.ti.com</a>
RFID	<a href="http://www.ti-rfid.com">www.ti-rfid.com</a>
OMAP Applications Processors	<a href="http://www.ti.com/omap">www.ti.com/omap</a>
Wireless Connectivity	<a href="http://www.ti.com/wirelessconnectivity">www.ti.com/wirelessconnectivity</a>

### Applications

Automotive and Transportation	<a href="http://www.ti.com/automotive">www.ti.com/automotive</a>
Communications and Telecom	<a href="http://www.ti.com/communications">www.ti.com/communications</a>
Computers and Peripherals	<a href="http://www.ti.com/computers">www.ti.com/computers</a>
Consumer Electronics	<a href="http://www.ti.com/consumer-apps">www.ti.com/consumer-apps</a>
Energy and Lighting	<a href="http://www.ti.com/energy">www.ti.com/energy</a>
Industrial	<a href="http://www.ti.com/industrial">www.ti.com/industrial</a>
Medical	<a href="http://www.ti.com/medical">www.ti.com/medical</a>
Security	<a href="http://www.ti.com/security">www.ti.com/security</a>
Space, Avionics and Defense	<a href="http://www.ti.com/space-avionics-defense">www.ti.com/space-avionics-defense</a>
Video and Imaging	<a href="http://www.ti.com/video">www.ti.com/video</a>

### TI E2E Community

[e2e.ti.com](http://e2e.ti.com)

## Looking for pricing, stock, or lifecycle information?

Click below to explore more details on WIN SOURCE:

 [View CD74ACT297M](#) on WIN SOURCE

 [Texas Instruments](#) Information

## Optimize Your Supply Chain with WIN SOURCE Solutions

-  Global Sourcing Solution
-  Obsolete Management
-  Cost Control Management
-  Shortage Management
-  Alternative Solution
-  Excess Inventory Management