

30 W Digital Audio Amplifier with Integrated ADC

Digital Amplifier Features

- ◆ Fully Integrated Power MOSFETs
- ◆ No Heatsink Required
 - Programmable Power Foldback on Thermal Warning
 - High Efficiency
- ◆ > 100 dB Dynamic Range
- ◆ < 0.1% THD+N @ 1 W
- ◆ Configurable Outputs (10% THD+N)
 - 1 x 30 W into 4 Ω, Parallel Full-Bridge
 - 2 x 15 W into 8 Ω, Full-Bridge
 - 2 x 7 W into 4 Ω, Half-Bridge + 1 x 15 W into 8 Ω, Full-Bridge
- ◆ Built-In Protection with Error Reporting
 - Overcurrent/Undervoltage/Thermal Overload Shutdown
 - Thermal Warning Reporting
- ◆ PWM Popguard® for Half-Bridge Mode
- ◆ Click-Free Start-Up
- ◆ Programmable Channel Delay for System Noise & Radiated Emissions Management

ADC Features

- ◆ Stereo, 24-bit, 48 kHz Conversion
- ◆ Multi-bit Architecture
- ◆ 95 dB Dynamic Range (A-wtd)
- ◆ -86 dB THD+N
- ◆ Supports 2 Vrms Input with Passive Components

System Features

- ◆ Asynchronous 2-Channel Digital Serial Port
- ◆ 32 kHz to 96 kHz Input Sample Rates
- ◆ Operation with On-Chip Oscillator Driver or Applied SYS_CLK at 18.432, 24.576 or 27.000 MHz
- ◆ Integrated Sample Rate Converter (SRC)
 - Eliminates Clock-Jitter Effects
 - Input Sample Rate Independent Operation
 - Simplifies System Integration
- ◆ Spread Spectrum PWM Modulation
 - Reduces EMI Radiated Energy
- ◆ Low Quiescent Current

(Features continued on page 2)

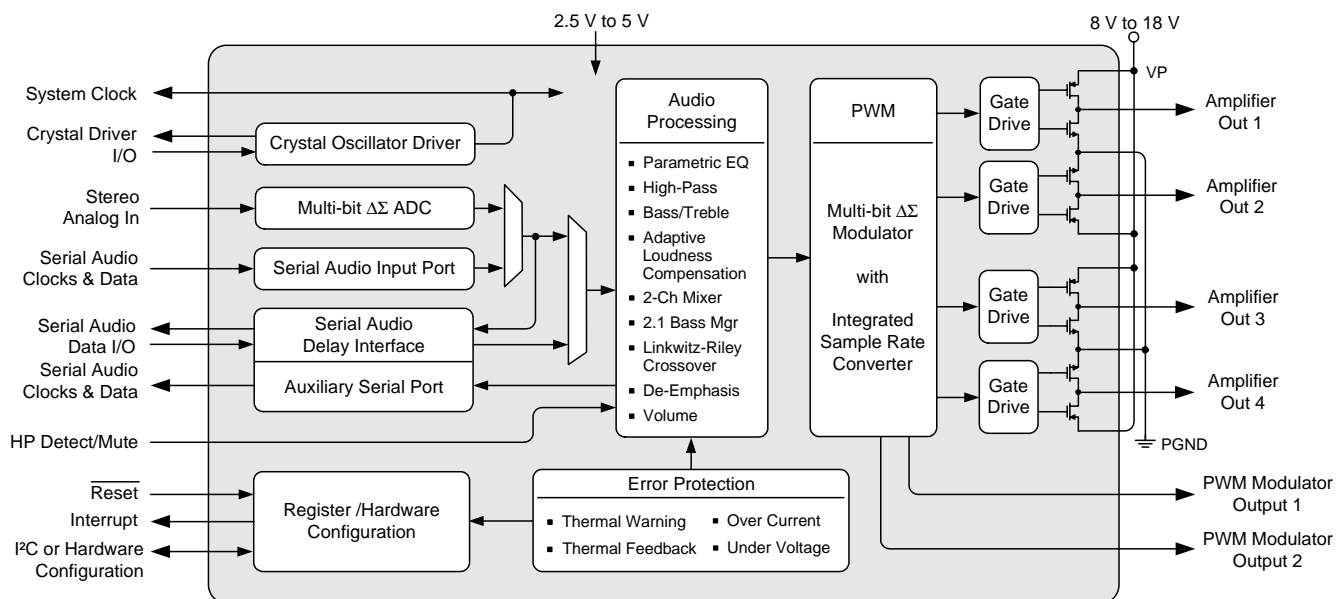

Preliminary Product Information

This document contains information for a new product. Cirrus Logic reserves the right to modify this product without notice.

Software Mode System Features

- ◆ Digital Audio Processing
 - 5 Programmable Parametric EQ Filters
 - Selectable High-Pass Filter
 - Bass/Treble Tone Control
 - Adaptive Loudness Compensation
 - 2-Channel Mixer
 - 2.1 Bass Management
 - 24 dB/octave Linkwitz-Riley Crossover Filters
 - De-emphasis Filter
- ◆ Selectable Serial Audio Interface Formats
 - Left-Justified up to 24-bit
 - I²S up to 24-bit
 - Right-Justified 16-, 18-, 20-, 24-bits
- ◆ Digital Serial Connection to Additional CS4525 or DACs for Subwoofer
- ◆ Digital Interface to External Lip-Sync Delay
- ◆ PWM Switch Rate Shifting Eliminates AM Frequency Interference
- ◆ Digital Volume Control with Soft ramp
 - +24 to -103 dB in 0.5 dB steps
- ◆ Programmable Peak Detect and Limiter
- ◆ 2-Channel Logic-Level PWM Output
 - Programmable Channel Mapping
 - Can Drive an External PWM Amplifier, Headphone Amplifier, or Line-Out Amplifier
 - Integrated Headphone Detection
- ◆ Flexible Power Output Configurations
- ◆ Thermal Foldback for Interruption-Free Power-Stage Protection
 - Supports Internal and External Power Stages
- ◆ Operation from On-Chip Oscillator Driver or Applied Systems Clock
- ◆ Supports I²C[®] Host Control Interface

Hardware Mode System Features

- ◆ 2-Channel Stereo Full-Bridge Power Outputs
- ◆ Analog and Digital Inputs
- ◆ I²S and Left-Justified Serial Input Formats
- ◆ Thermal Foldback for Interruption-Free Protection of Internal Power Stage
- ◆ Operation from Applied Systems Clock
- ◆ External Mute Input

Common Applications

- ◆ Integrated Digital TV's
- ◆ Flat Panel TV Monitors
- ◆ Computer/TV Monitors
- ◆ Mini/Micro Shelf Systems
- ◆ Digital Powered Speakers
- ◆ Portable Docking Stations
- ◆ Computer Desktop Audio

General Description

The CS4525 is a stereo analog or digital input PWM high efficiency Class D amplifier audio system with an integrated stereo analog-to-digital (A/D) converter. The stereo power amplifiers can deliver up to 15 W per channel into 8 Ω speakers from a small space-saving 48-pin QFN package. The PWM amplifier can achieve greater than 85% efficiency. The package is thermally enhanced for optimal heat dissipation which eliminates the need for a heatsink.

The power stage outputs can be configured as two full-bridge channels for 2 x 15 W operation, two half-bridge channels and one full-bridge channel for 2 x 7 W + 1 x 15 W operation, or one parallel full-bridge channel for 1 x 30 W operation. The CS4525 integrates on-chip over-current, under-voltage, and over-temperature protection and error reporting as well as a thermal warning indicator and programmable foldback of the output power to allow cooling.

The main digital serial port on the CS4525 can support asynchronous operation with the integrated on-chip sample rate converter (SRC) which eases system integration. The SRC allows for a fixed PWM switching frequency regardless of incoming sample rate as well as optimal clocking for the A/D modulators.

An on-chip oscillator driver eliminates the need for an external crystal oscillator circuit, reducing overall design cost and conserving circuit board space. The CS4525 automatically uses the on-chip oscillator driver in the absence of an applied master clock.

The CS4525 is available in a 48-pin QFN package in Commercial grade (-10° to +70° C). The CRD4525-Q1 4-layer, 1 oz. copper and CRD4525-D1 2-layer, 1 oz. copper customer reference designs are also available.

Please refer to [“Ordering Information” on page 97](#) for complete ordering information.

TABLE OF CONTENTS

1. PIN DESCRIPTIONS - SOFTWARE MODE	8
2. PIN DESCRIPTIONS - HARDWARE MODE	10
2.1 Digital I/O Pin Characteristics	12
3. TYPICAL CONNECTION DIAGRAMS	13
4. TYPICAL SYSTEM CONFIGURATION DIAGRAMS	15
5. CHARACTERISTICS AND SPECIFICATIONS	18
6. APPLICATIONS	26
6.1 Software Mode	26
6.1.1 System Clocking	26
6.1.1.1 SYS_CLK Input Clock Mode	26
6.1.1.2 Crystal Oscillator Mode	27
6.1.2 Power-Up and Power-Down	28
6.1.2.1 Recommended Power-Up Sequence	28
6.1.2.2 Recommended Power-Down Sequence	28
6.1.3 Input Source Selection	29
6.1.4 Digital Sound Processing	29
6.1.4.1 Pre-Scaler	30
6.1.4.2 Digital Signal Processing High-Pass Filter	30
6.1.4.3 Channel Mixer	30
6.1.4.4 De-Emphasis	31
6.1.4.5 Tone Control	31
6.1.4.6 Parametric EQ	33
6.1.4.7 Adaptive Loudness Compensation	34
6.1.4.8 Bass Management	35
6.1.4.9 Volume and Muting Control	36
6.1.4.10 Peak Signal Limiter	37
6.1.4.11 Thermal Limiter	39
6.1.4.12 Thermal Foldback	40
6.1.4.13 2-Way Crossover & Sensitivity Control	41
6.1.5 Auxiliary Serial Output	43
6.1.6 Serial Audio Delay & Warning Input Port	44
6.1.6.1 Serial Audio Delay Interface	44
6.1.6.2 External Warning Input Port	44
6.1.7 Powered PWM Outputs	45
6.1.7.1 Output Channel Configurations	45
6.1.7.2 PWM Popguard Transient Control	45
6.1.8 Logic-Level PWM Outputs	46
6.1.8.1 Recommended PWM_SIG Power-Up Sequence for an External PWM Amplifier	47
6.1.8.2 Recommended PWM_SIG Power-Down Sequence for an External PWM Amplifier	47
6.1.8.3 Recommended PWM_SIG Power-Up Sequence for Headphone & Line-Out	48
6.1.8.4 Recommended PWM_SIG Power-Down Sequence for Headphone & Line-Out	48
6.1.8.5 PWM_SIG Logic-Level Output Configurations	49
6.1.9 PWM Modulator Configuration	50
6.1.9.1 PWM Channel Delay	50
6.1.9.2 PWM AM Frequency Shift	51
6.1.10 Headphone Detection & Hardware Mute Input	51
6.1.11 Interrupt Reporting	53
6.1.12 Automatic Power Stage Shut-Down	53
6.2 Hardware Mode	54
6.2.1 System Clocking	54
6.2.2 Power-Up and Power-Down	54
6.2.2.1 Recommended Power-Up Sequence	54

6.2.2.2 Recommended Power-Down Sequence	55
6.2.3 Input Source Selection	55
6.2.4 PWM Channel Delay	55
6.2.5 Digital Signal Flow	56
6.2.5.1 High-Pass Filter	56
6.2.5.2 Mute Control	56
6.2.5.3 Warning and Error Reporting	56
6.2.6 Thermal Foldback	57
6.2.7 Automatic Power Stage Shut-Down	58
6.3 PWM Modulators and Sample Rate Converters	58
6.4 Output Filters	59
6.4.1 Half-Bridge Output Filter	59
6.4.2 Full-Bridge Output Filter (Stereo or Parallel)	60
6.5 Analog Inputs	61
6.6 Serial Audio Interfaces	62
6.6.1 I ² S Data Format	62
6.6.2 Left-Justified Data Format	62
6.6.3 Right-Justified Data Format	63
6.7 Integrated VD Regulator	63
6.8 I ² C Control Port Description and Timing	64
7. PCB LAYOUT CONSIDERATIONS	65
7.1 Power Supply, Grounding	65
7.2 QFN Thermal Pad	65
8. REGISTER QUICK REFERENCE	66
9. REGISTER DESCRIPTIONS	69
9.1 Clock Configuration (Address 01h)	69
9.1.1 SYS_CLK Output Enable (EnSysClk)	69
9.1.2 SYS_CLK Output Divider (DivSysClk)	69
9.1.3 Clock Frequency (ClkFreq[1:0])	69
9.1.4 HP_Detect/Mute Pin Active Logic Level (HP/MutePol)	70
9.1.5 HP_Detect/Mute Pin Mode (HP/Mute)	70
9.1.6 Modulator Phase Shifting (PhaseShift)	70
9.1.7 AM Frequency Shifting (FreqShift)	70
9.2 Input Configuration (Address 02h)	71
9.2.1 Input Source Selection (ADC/SP)	71
9.2.2 ADC High-Pass Filter Enable (EnAnHPF)	71
9.2.3 Serial Port Sample Rate (SPRate[1:0]) - Read Only	71
9.2.4 Input Serial Port Digital Interface Format (DIF [2:0])	71
9.3 AUX Port Configuration (Address 03h)	72
9.3.1 Enable Aux Serial Port (EnAuxPort)	72
9.3.2 Delay & Warning Port Configuration (DlyPortCfg[1:0])	72
9.3.3 Aux/Delay Serial Port Digital Interface Format (AuxI ² S/LJ)	72
9.3.4 Aux Serial Port Right Channel Data Select (RChDSEL[1:0])	72
9.3.5 Aux Serial Port Left Channel Data Select (LChDSEL[1:0])	73
9.4 Output Configuration (Address 04h)	73
9.4.1 Output Configuration (OutputCfg[1:0])	73
9.4.2 PWM Signals Output Data Select (PWMDSEL[1:0])	73
9.4.3 Channel Delay Settings (OutputDly[3:0])	73
9.5 Foldback and Ramp Configuration (Address 05h)	74
9.5.1 Select VP Level (SelectVP)	74
9.5.2 Enable Thermal Foldback (EnTherm)	74
9.5.3 Lock Foldback Adjust (LockAdj)	74
9.5.4 Foldback Attack Delay (AttackDly[1:0])	75
9.5.5 Enable Foldback Floor (EnFloor)	75

9.5.6 Ramp Speed (RmpSpd[1:0])	75
9.6 Mixer / Pre-Scale Configuration (Address 06h)	75
9.6.1 Pre-Scale Attenuation (PreScale[2:0])	75
9.6.2 Right Channel Mixer (RChMix[1:0])	76
9.6.3 Left Channel Mixer (LChMix[1:0])	76
9.7 Tone Configuration (Address 07h)	76
9.7.1 De-Emphasis Control (DeEmph)	76
9.7.2 Adaptive Loudness Compensation Control (Loudness)	76
9.7.3 Digital Signal Processing High-Pass Filter (EnDigHPF)	77
9.7.4 Treble Corner Frequency (TrebFc[1:0])	77
9.7.5 Bass Corner Frequency (BassFc[1:0])	77
9.7.6 Tone Control Enable (EnToneCtrl)	77
9.8 Tone Control (Address 08h)	78
9.8.1 Treble Gain Level (Treb[3:0])	78
9.8.2 Bass Gain Level (Bass[3:0])	78
9.9 2.1 Bass Manager/Parametric EQ Control (Address 09h)	78
9.9.1 Freeze Controls (Freeze)	78
9.9.2 Hi-Z PWM_SIG Outputs (HiZPSig)	79
9.9.3 Bass Cross-Over Frequency (BassMgr[2:0])	79
9.9.4 Enable Channel B Parametric EQ (EnChBPEq)	79
9.9.5 Enable Channel A Parametric EQ (EnChAPEq)	79
9.10 Volume and 2-Way Cross-Over Configuration (Address 55h)	80
9.10.1 Soft Ramp and Zero Cross Control (SZCMode[1:0])	80
9.10.2 Enable 50% Duty Cycle for Mute Condition (Mute50/50)	80
9.10.3 Auto-Mute (AutoMute)	80
9.10.4 Enable 2-Way Crossover (En2Way)	81
9.10.5 2-Way Cross-Over Frequency (2WayFreq[2:0])	81
9.11 Channel A & B: 2-Way Sensitivity Control (Address 56h)	81
9.11.1 Channel A and Channel B Low-Pass Sensitivity Adjust (LowPass[3:0])	81
9.11.2 Channel A and Channel B High-Pass Sensitivity Adjust (HighPass[3:0])	82
9.12 Master Volume Control (Address 57h)	82
9.12.1 Master Volume Control (MVol[7:0])	82
9.13 Channel A and B Volume Control (Address 58h & 59h)	83
9.13.1 Channel X Volume Control (ChXVol[7:0])	83
9.14 Sub Channel Volume Control (Address 5Ah)	83
9.14.1 Sub Channel Volume Control (SubVol[7:0])	83
9.15 Mute/Invert Control (Address 5Bh)	84
9.15.1 ADC Invert Signal Polarity (InvADC)	84
9.15.2 Invert Channel PWM Signal Polarity (InvChX)	84
9.15.3 Invert Sub PWM Signal Polarity (InvSub)	84
9.15.4 ADC Channel Mute (MuteADC)	84
9.15.5 Independent Channel A & B Mute (MuteChX)	84
9.15.6 Sub Channel Mute (MuteSub)	85
9.16 Limiter Configuration 1 (Address 5Ch)	85
9.16.1 Maximum Threshold (Max[2:0])	85
9.16.2 Minimum Threshold (Min[2:0])	85
9.16.3 Peak Signal Limit All Channels (LimitAll)	86
9.16.4 Peak Detect and Limiter Enable (EnLimiter)	86
9.17 Limiter Configuration 2 (Address 5Dh)	87
9.17.1 Limiter Release Rate (RRate[5:0])	87
9.18 Limiter Configuration 3 (Address 5Eh)	87
9.18.1 Enable Thermal Limiter (EnThLim)	87
9.18.2 Limiter Attack Rate (ARate[5:0])	87
9.19 Power Control (Address 5Fh)	88

9.19.1 Automatic Power Stage Retry (AutoRetry)	88
9.19.2 Enable Over-Current Protection (EnOCProt)	88
9.19.3 Select VD Level (SelectVD)	88
9.19.4 Power Down ADC (PDnADC)	88
9.19.5 Power Down PWM Power Output X (PDnOutX)	88
9.19.6 Power Down (PDnAll)	89
9.20 Interrupt (Address 60h)	89
9.20.1 SRC Lock State Transition Interrupt (SRCLock)	89
9.20.2 ADC Overflow Interrupt (ADCOvfl)	90
9.20.3 Channel Overflow Interrupt (ChOvfl)	90
9.20.4 Amplifier Error Interrupt Bit (AmpErr)	90
9.20.5 Mask for SRC State (SRCLockM)	91
9.20.6 Mask for ADC Overflow (ADCOvflM)	91
9.20.7 Mask for Channel X and Sub Overflow (ChOvflM)	91
9.20.8 Mask for Amplifier Error (AmpErrM)	92
9.21 Interrupt Status (Address 61h) - Read Only	92
9.21.1 SRC State Transition (SRCLockSt)	92
9.21.2 ADC Overflow (ADCOvflSt)	92
9.21.3 Sub Overflow (SubOvflSt)	92
9.21.4 Channel X Overflow (ChXOvflSt)	93
9.21.5 Ramp-Up Cycle Complete (RampDone)	93
9.22 Amplifier Error Status (Address 62h) - Read Only	93
9.22.1 Over-Current Detected On Channel X (OverCurrX)	93
9.22.2 External Amplifier State (ExtAmpSt)	93
9.22.3 Under Voltage / Thermal Error State (UVTE[1:0])	94
9.23 Device I.D. and Revision (Address 63h) - Read Only	94
9.23.1 Device Identification (DeviceID[4:0])	94
9.23.2 Device Revision (RevID[2:0])	94
10. PARAMETER DEFINITIONS	95
11. REFERENCES	95
12. PACKAGE DIMENSIONS	96
13. THERMAL CHARACTERISTICS	97
13.1 Thermal Flag	97
14. ORDERING INFORMATION	97
15. REVISION HISTORY	98

LIST OF FIGURES

Figure 1. Typical Connection Diagram - Software Mode	13
Figure 2. Typical Connection Diagram - Hardware Mode	14
Figure 3. Typical System Configuration 1	15
Figure 4. Typical System Configuration 2	15
Figure 5. Typical System Configuration 3	16
Figure 6. Typical System Configuration 4	17
Figure 7. Serial Audio Input Port Timing	21
Figure 8. AUX Serial Port Interface Master Mode Timing	22
Figure 9. SYS_CLK Timing from Reset	23
Figure 10. PWM_SIGX Timing	23
Figure 11. Control Port Timing - I ² C	24
Figure 12. Typical SYS_CLK Input Clocking Configuration	26
Figure 13. Typical Crystal Oscillator Clocking Configuration	27
Figure 14. Digital Signal Flow	29
Figure 15. De-Emphasis Filter	31
Figure 16. Bi-Quad Filter Architecture	33

Figure 17. Peak Signal Detection & Limiting	37
Figure 18. Foldback Process	40
Figure 19. Popguard Connection Diagram	46
Figure 20. 2-Channel Full-Bridge PWM Output Delay	50
Figure 21. 3-Channel PWM Output Delay	50
Figure 22. Typical SYS_CLK Input Clocking Configuration	54
Figure 23. Hardware Mode PWM Output Delay	55
Figure 24. Hardware Mode Digital Signal Flow	56
Figure 25. Foldback Process	57
Figure 26. Output Filter - Half-Bridge	59
Figure 27. Output Filter - Full-Bridge	60
Figure 28. Recommended Unity Gain Input Filter	61
Figure 29. Recommended 2 V _{RMS} Input Filter	61
Figure 30. I ² S Serial Audio Formats	62
Figure 31. Left-Justified Serial Audio Formats	62
Figure 32. Right-Justified Serial Audio Formats	63
Figure 33. Control Port Timing, I ² C Write	64
Figure 34. Control Port Timing, I ² C Read	64

LIST OF TABLES

Table 1. I/O Power Rails	12
Table 2. Bass Shelving Filter Corner Frequencies	31
Table 3. Treble Shelving Filter Corner Frequencies	32
Table 4. Bass Management Cross-Over Frequencies	35
Table 5. 2-Way Cross-Over Frequencies	41
Table 6. Auxiliary Serial Port Data Output	43
Table 7. Nominal Switching Frequencies of the Auxiliary Serial Output	43
Table 8. PWM Power Output Configurations	45
Table 9. Typical Ramp Times for Various VP Voltages	46
Table 10. PWM Logic-Level Output Configurations	49
Table 11. PWM Output Switching Rates and Quantization Levels	51
Table 12. Output of PWM_SIG Outputs	52
Table 13. SYS_CLOCK Frequency Selection	54
Table 14. Input Source Selection	55
Table 15. Serial Audio Interface Format Selection	55
Table 16. Thermal Foldback Enable Selection	57
Table 17. PWM Output Switching Rates and Quantization Levels	58
Table 18. Low-Pass Filter Components - Half-Bridge	59
Table 19. DC-Blocking Capacitors Values - Half-Bridge	59
Table 20. Low-Pass Filter Components - Full-Bridge	60
Table 21. Power Supply Configuration and Settings	63

1. PIN DESCRIPTIONS - SOFTWARE MODE

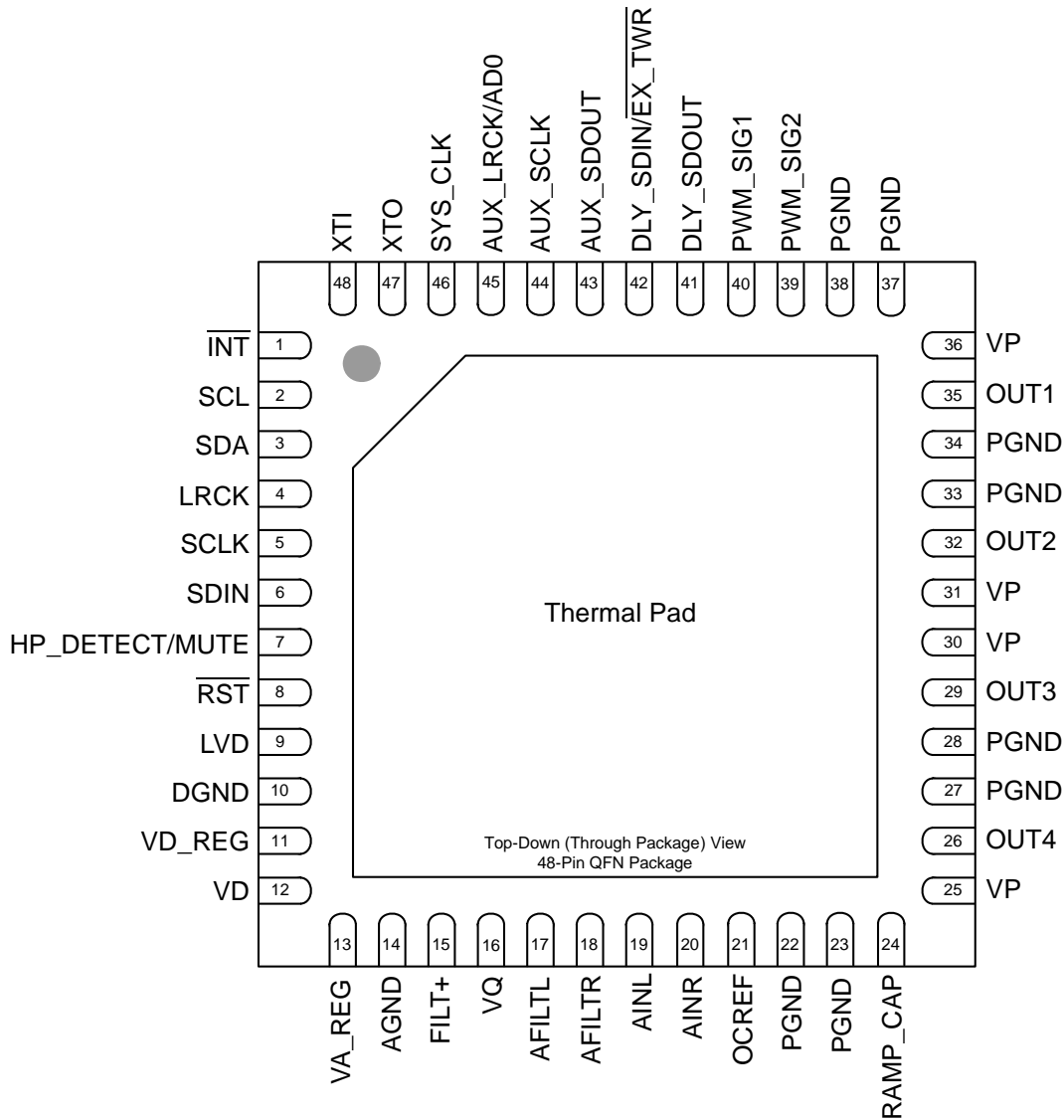

Pin Name	Pin #	Pin Description
$\overline{\text{INT}}$	1	Interrupt (Output) - Indicates an interrupt condition has occurred.
SCL	2	Serial Control Port Clock (Input) - Serial clock for the I ² C control port.
SDA	3	Serial Control Data (Input/Output) - Bi-directional data I/O for the I ² C control port.
LRCK	4	Left Right Clock (Input) - Determines which channel, Left or Right, is currently active on the serial audio data line.
SCLK	5	Serial Clock (Input) - Serial bit clock for the serial audio interface.
SDIN	6	Serial Audio Data Input (Input) - Input for two's complement serial audio data.
HP_DETECT/ MUTE	7	Headphone Detect / Mute (Input) - Headphone detection or mute input signal as configured via the I ² C control port.
$\overline{\text{RST}}$	8	Reset (Input) - The device enters a low power mode and all internal registers are reset to their default settings when this pin is driven low.

LVD	9	VD Voltage Level Indicator (Input) - Identifies the voltage level attached to VD. When applying 5.0 V to VD, LVD must be connected to VD. When applying 2.5 V or 3.3 V to VD, LVD must be DGND.
DGND	10	Digital Ground (Input) - Ground for the internal logic and digital I/O.
VD_REG	11	Core Logic Power (Output) - Internally generated low voltage power supply for digital logic.
VD	12	Power (Input) - Positive power supply for the internal regulators and digital I/O.
VA_REG	13	Analog Power (Output) - Internally generated positive power for the analog section and I/O.
AGND	14	Analog Ground (Input) - Ground reference for the internal analog section and I/O.
FILT+	15	Positive Voltage Reference (Output) - Positive reference voltage for the internal ADC sampling circuits.
VQ	16	Common Mode Voltage (Output) - Filter connection for internal common mode voltage.
AFILT	17	Antialias Filter Connection (Output) - Antialias filter connection for ADC inputs.
AFILTR	18	
AINL	19	Analog Input (Input) - The full-scale input level is specified in the ADC Analog Characteristics specification table.
AINR	20	
OCREF	21	Over Current Reference Setting (Input) - Sets the reference for over current detection.
PGND	22,23 27,28 33,34 37,38	Power Ground (Input) - Ground for the individual output power half-bridge devices.
RAMP_CAP	24	Output Ramp Capacitor (Input) - Used by the PWM Popguard Transient Control to suppress the initial pop in half-bridge-configured outputs.
VP	25,30, 31,36	High Voltage Power (Input) - High voltage power supply for the individual half-bridge devices.
OUT4	26	PWM Output (Output) - Amplified PWM power outputs.
OUT3	29	
OUT2	32	
OUT1	35	
PWM_SIG2	39	Logic Level PWM Output (Output) - Logic Level PWM switching signals.
PWM_SIG1	40	
DLY_SDOUT	41	Delay Serial Audio Data Out (Output) - Output for two's complement serial audio data.
DLY_SDIN/ EX_TWR	42	Delay Serial Audio Data Input (Input) - Input for two's complement serial audio data. External Thermal Warning (Input) - Input for an external thermal warning signal. Configurable via the I ² C control port.
AUX_SDOUT	43	Auxiliary Port Serial Audio Data Out (Output) - Output for two's complement auxiliary port serial data.
AUX_SCLK	44	Auxiliary Port Serial Clock (Output) - Serial clock for the auxiliary port serial interface.
AUX_LRCK/ AD0	45	Auxiliary Port Left Right Clock (Output) - Determines which channel, Left or Right, is currently active on the serial audio data line. AD0 (Input) - Sets the LSB of the I ² C device address. Sensed on the release of $\overline{\text{RST}}$.
SYS_CLK	46	System Clock (Input/Output) - Clock source for the internal logic, processing, and modulators. This pin should be connected to through a 10k Ω to ground when unused.
XTO	47	Crystal Oscillator Output (Output) - Crystal oscillator driver output.
XTI	48	Crystal Oscillator Input (Input) - Crystal oscillator driver input.
Thermal Pad	-	Thermal Pad - Thermal relief pad for optimized heat dissipation. See "QFN Thermal Pad" on page 65 for more information.

2. PIN DESCRIPTIONS - HARDWARE MODE

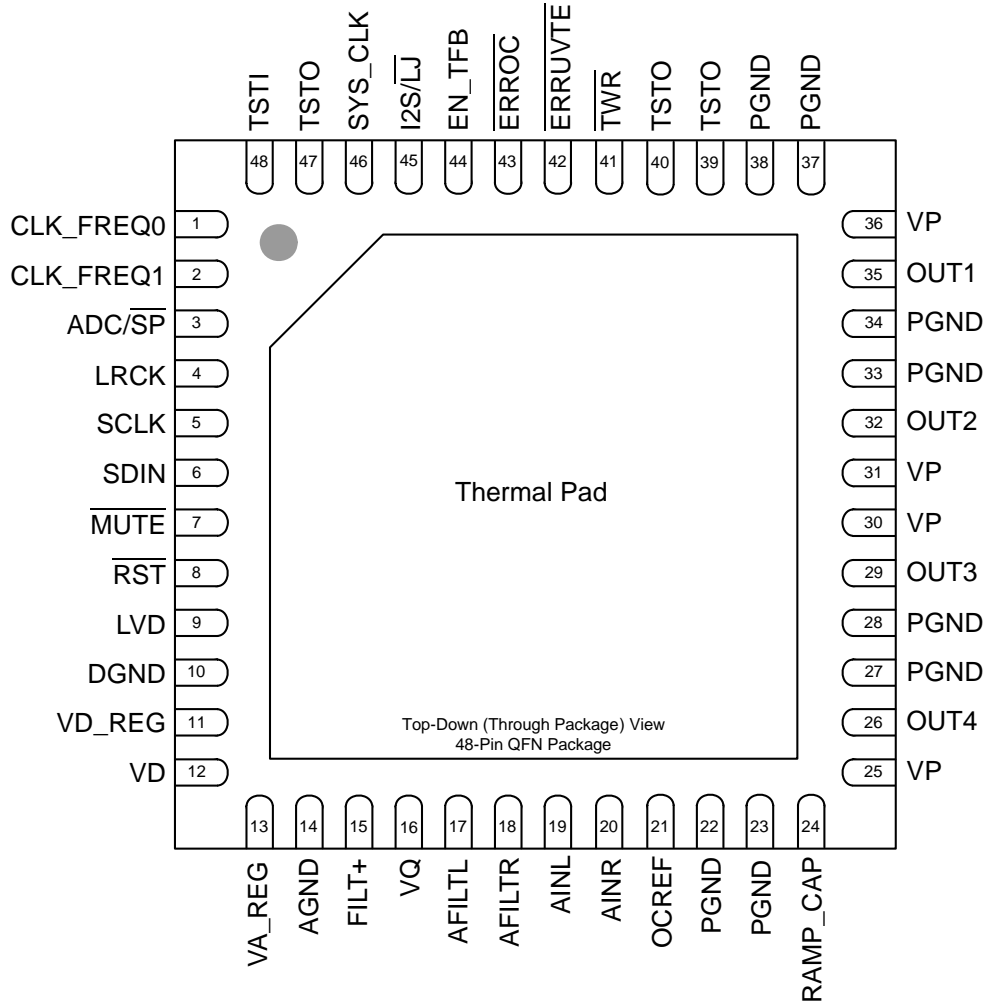

Pin Name	Pin #	Pin Description
CLK_FREQ0	1	Clock Frequency (Input) - Determines the frequency of the clock expected to be driven into the SYS_CLK pin.
CLK_FREQ1	2	
ADC/SP	3	ADC/Serial Port (Input) - Selects between the Analog to Digital Converter and the Serial Port for audio input. Selects the ADC when high or the serial port when low.
LRCK	4	Left Right Clock (Input) - Determines which channel, Left or Right, is currently active on the serial audio data line.
SCLK	5	Serial Clock (Input) - Serial bit clock for the serial audio interface.
SDIN	6	Serial Audio Data Input (Input) - Input for two's complement serial audio data.
MUTE	7	Mute (Input) - The PWM outputs will output silence as a 50% duty cycle signal when this pin is driven low.
RST	8	Reset (Input) - The device enters a low power mode and all internal registers are reset to their default settings when this pin is driven low.

LVD	9	VD Voltage Level Indicator (Input) - Identifies the voltage level attached to VD. When applying 5.0 V to VD, LVD must be connected to VD. When applying 2.5 V or 3.3 V to VD, LVD must be connected to DGND.
DGND	10	Digital Ground (Input) - Ground for the internal logic and I/O.
VD_REG	11	Core Logic Power (Output) - Internally generated low voltage power supply for digital logic.
VD	12	Digital Power (Input) - Positive power supply for the internal regulators and digital I/O.
VA_REG	13	Analog Power (Output) - Internally generated positive power for the analog section and I/O.
AGND	14	Analog Ground (Input) - Ground reference for the internal analog section and I/O.
FILT+	15	Positive Voltage Reference (Output) - Positive reference voltage for the internal ADC sampling circuits.
VQ	16	Common Mode Voltage (Output) - Filter connection for internal common mode voltage.
AFILT	17	Antialias Filter Connection (Output) - Antialias filter connection for ADC inputs.
AFILTR	18	
AINL	19	Analog Input (Input) - The full-scale input level is specified in the ADC Analog Characteristics specification table.
AINR	20	
OCREF	21	Over Current Reference Setting (Input) - Sets the reference for over current detection.
PGND	22,23 27,28 33,34 37,38	Power Ground (Input) - Ground for the individual output power half-bridge devices.
RAMP_CAP	24	Output Ramp Capacitor (Input) - This pin should be connected directly to VP in hardware mode.
VP	25,30, 31,36	High Voltage Power (Input) - High voltage power supply for the individual half-bridge devices.
OUT4	26	PWM Output (Output) - Amplified PWM power outputs.
OUT3	29	
OUT2	32	
OUT1	35	
TSTO	39 40	Test Output (Output) - These pins are outputs used for the Logic Level PWM switching signals available only in software mode. They must be left unconnected for hardware mode operation.
TWR	41	Thermal Warning Output (Output) - Thermal warning output.
$\overline{\text{ERRUVTE}}$	42	Thermal and Undervoltage Error Output (Output) - Error flag for thermal shutdown and undervoltage.
$\overline{\text{ERROC}}$	43	Overcurrent Error Output (Output) - Overcurrent error flag.
EN_TFB	44	Enable Thermal Feedback (Input) - Enables the thermal foldback feature when high.
I2S/LJ	45	I²S/Left Justified (Input) - Selects between I ² S and Left-Justified data format for the serial input port. Selects I ² S when high and LJ when low.
SYS_CLK	46	System Clock (Input/Output) - Clock source for the delta-sigma modulators.
TSTO	47	Test Output (Output) - This pin is an output used for the crystal oscillator driver available only in software mode. It must be left unconnected for normal hardware mode operation.
TSTI	48	Test Input (Input) - This pin is an input used for the crystal oscillator driver available only in software mode. It must be tied to digital ground for normal hardware mode operation.
Thermal Pad	-	Thermal Pad - Thermal relief pad for optimized heat dissipation. See “QFN Thermal Pad” on page 65 for more information.

2.1 Digital I/O Pin Characteristics

The logic level for each input is set by its corresponding power supply and should not exceed the maximum ratings.

Power Supply	Pin Number	Pin Name	I/O	Driver	Receiver	
Software Mode						
VD	1	INT	Output	2.5 V-5.0 V, Open Drain		
	2	SCL	Input	-	2.5 V-5.0 V, with Hysteresis	
	3	SDA	Input/Output	2.5 V-5.0 V, Open Drain	2.5 V-5.0 V, with Hysteresis	
	7	HP_DETECT	Input	-	2.5 V-5.0 V	
		MUTE	Input	-	2.5 V-5.0 V	
	41	DLY_SDO _{UT}	Output	2.5 V-5.0 V, CMOS	-	
	42	DLY_SDIN	Input	-	2.5 V-5.0 V	
		EX_TWR	Input	-	2.5 V-5.0 V	
VD	43	AUX_SDO _{UT}	Output	2.5 V-5.0 V, CMOS	-	
	44	AUX_SCLK	Output	2.5 V-5.0 V, CMOS	-	
	45	AUX_LRCK	Output	2.5 V-5.0 V, CMOS	-	
	VD_REG	39	PWM_SIG2	Output	2.5 V, CMOS	-
		40	PWM_SIG1	Output	2.5 V, CMOS	-
	Hardware Mode					
	VD	1	SEL_OSC0	Input	-	2.5 V-5.0 V
2		SEL_OSC1	Input	-	2.5 V-5.0 V	
3		ADC/SP	Input	-	2.5 V-5.0 V	
7		MUTE	Input	-	2.5 V-5.0 V	
41		TWR	Output	2.5 V-5.0 V, Open Drain	-	
42		ERRUVTE	Output	2.5 V-5.0 V, Open Drain	-	
43		ERROC	Output	2.5 V-5.0 V, Open Drain	-	
44		EN_TFB	Input	-	2.5 V-5.0 V	
	45	I ² S/LJ	Input	-	2.5 V-5.0 V	
All Modes						
VD	4	LRCK	Input	-	2.5 V-5.0 V	
	5	SCLK	Input	-	2.5 V-5.0 V	
	6	SDIN	Input	-	2.5 V-5.0 V	
	8	RST	Input	-	2.5 V-5.0 V	
	9	LVD	Input	-	2.5 V-5.0 V	
	46	SYS_CLK	Input/Output	2.5 V-5.0 V, CMOS	2.5 V-5.0 V	
VP	26	OUT4	Output	8.0 V-18.0 V Power MOSFET	-	
	29	OUT3	Output	8.0 V-18.0 V Power MOSFET	-	
	32	OUT2	Output	8.0 V-18.0 V Power MOSFET	-	
	35	OUT1	Output	8.0 V-18.0 V Power MOSFET	-	

Table 1. I/O Power Rails

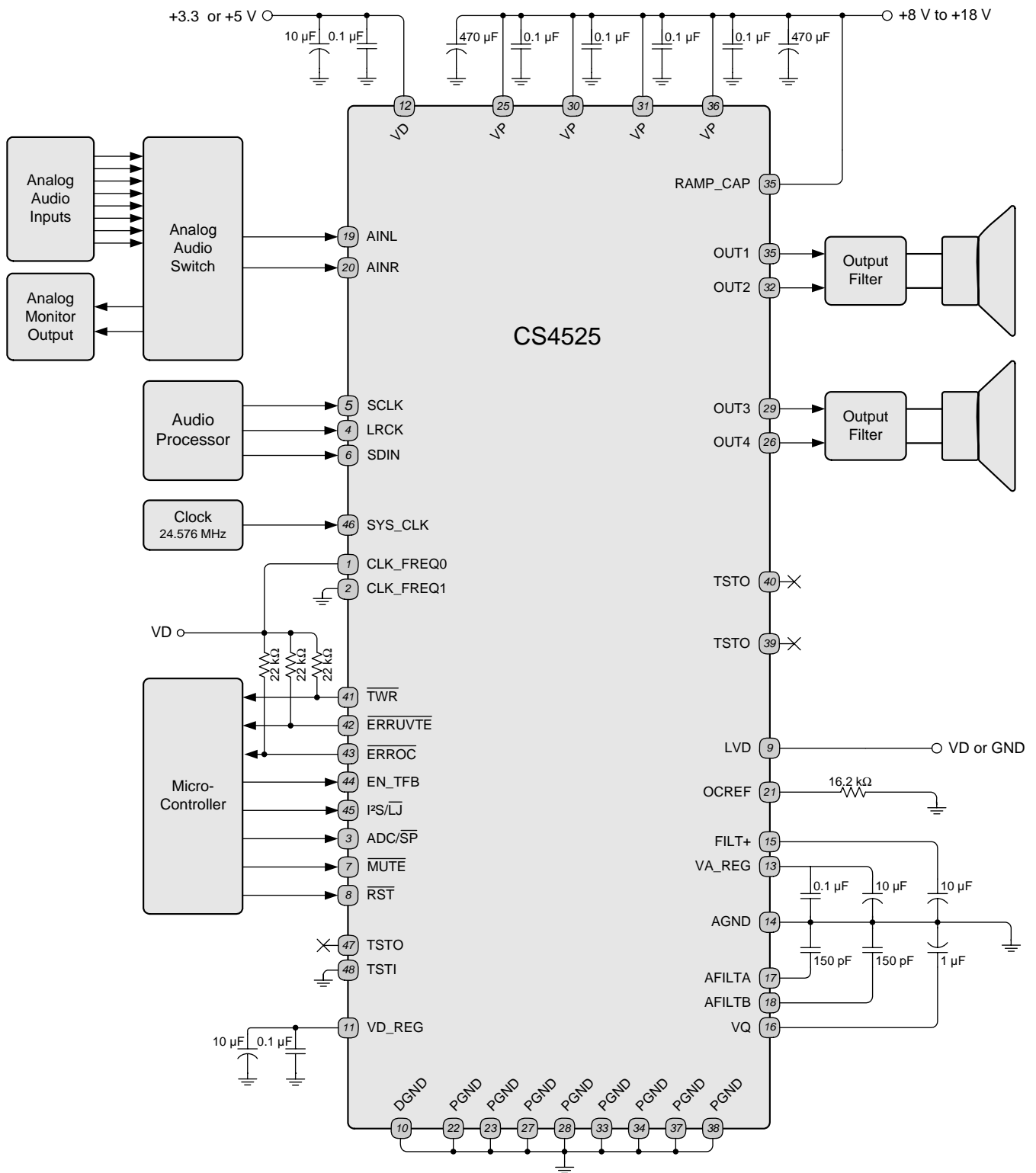

Figure 2. Typical Connection Diagram - Hardware Mode

4. TYPICAL SYSTEM CONFIGURATION DIAGRAMS

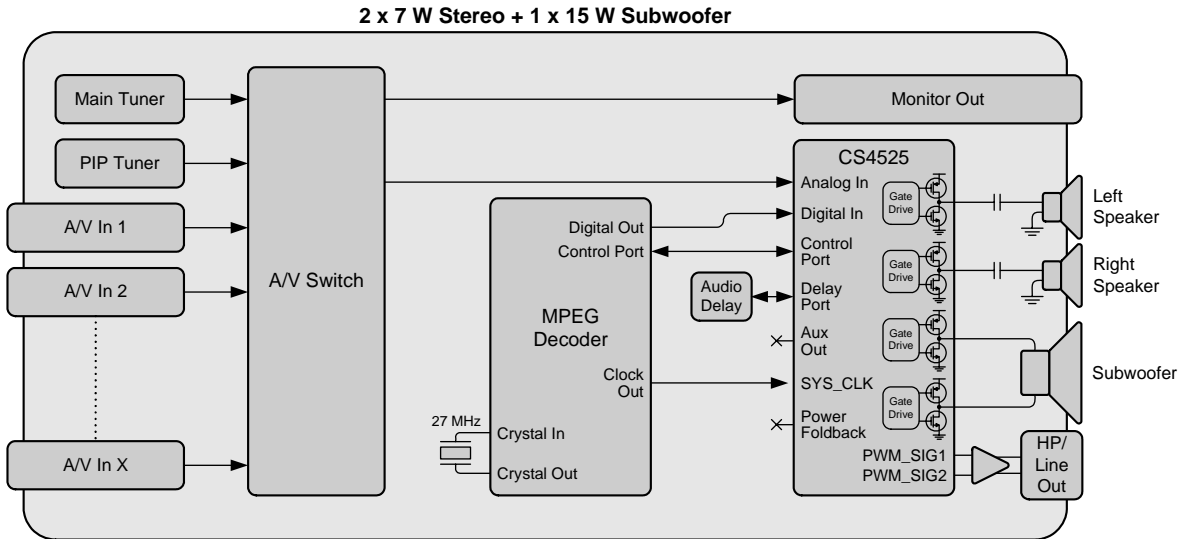

Figure 3. Typical System Configuration 1

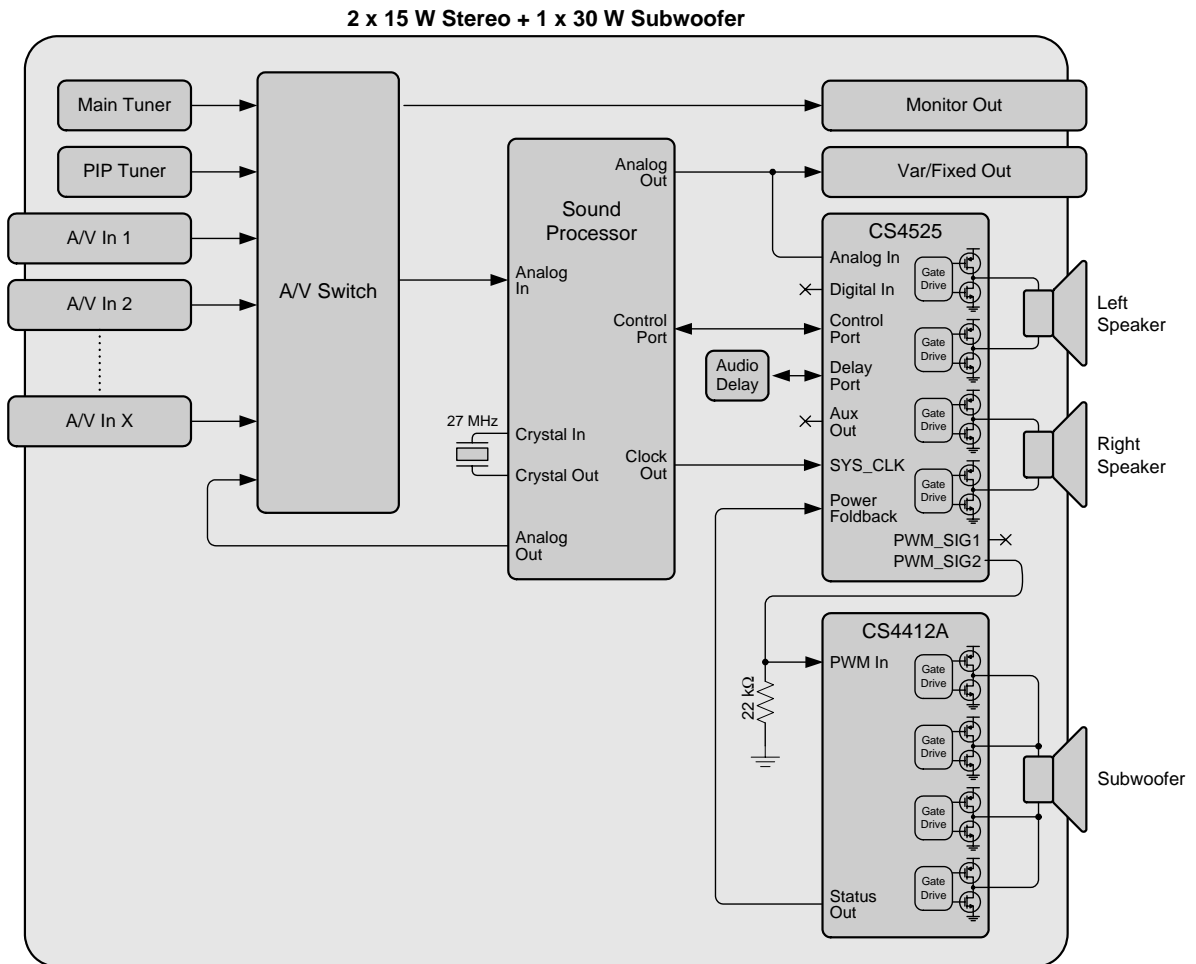

Figure 4. Typical System Configuration 2

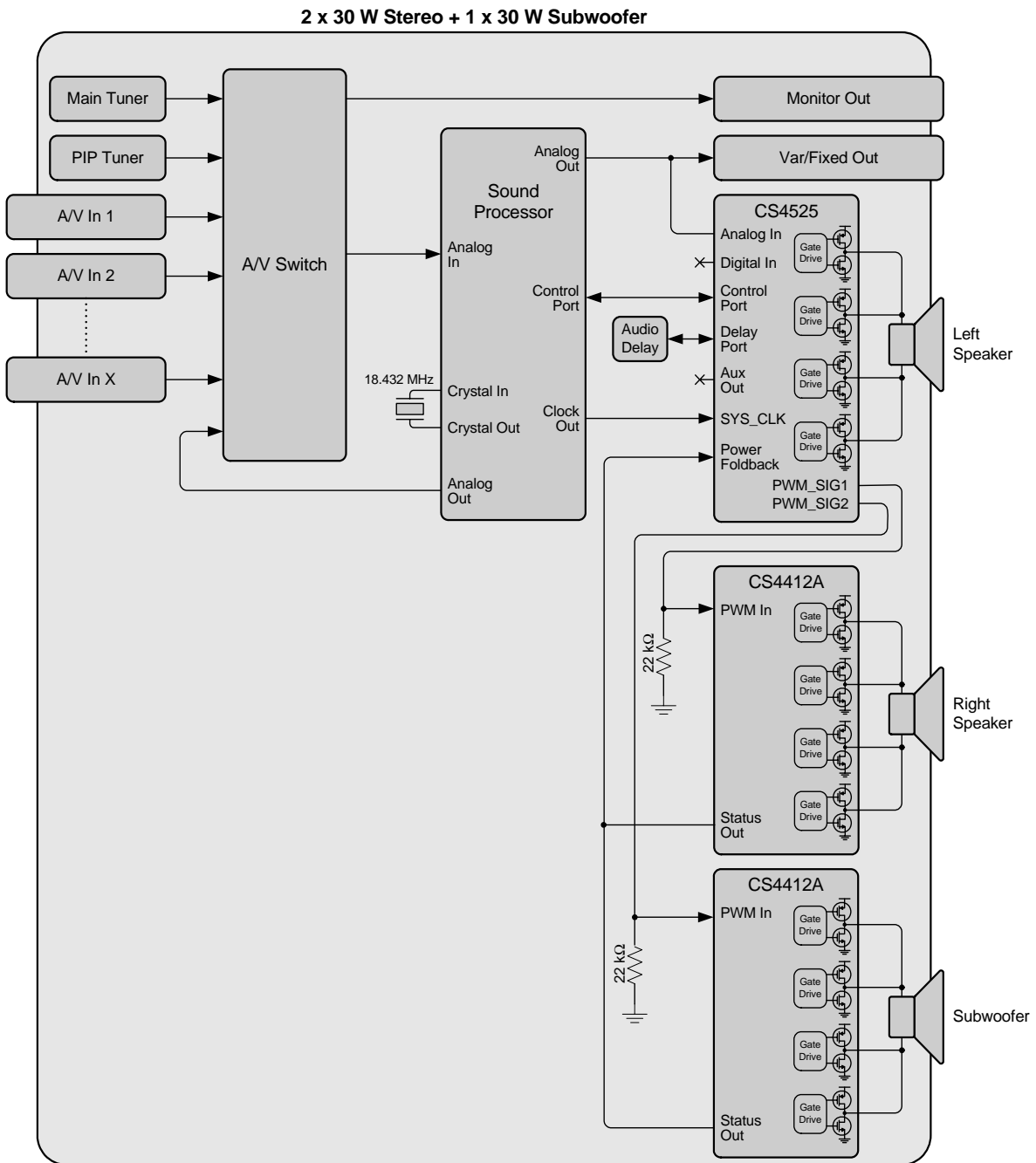

Figure 5. Typical System Configuration 3

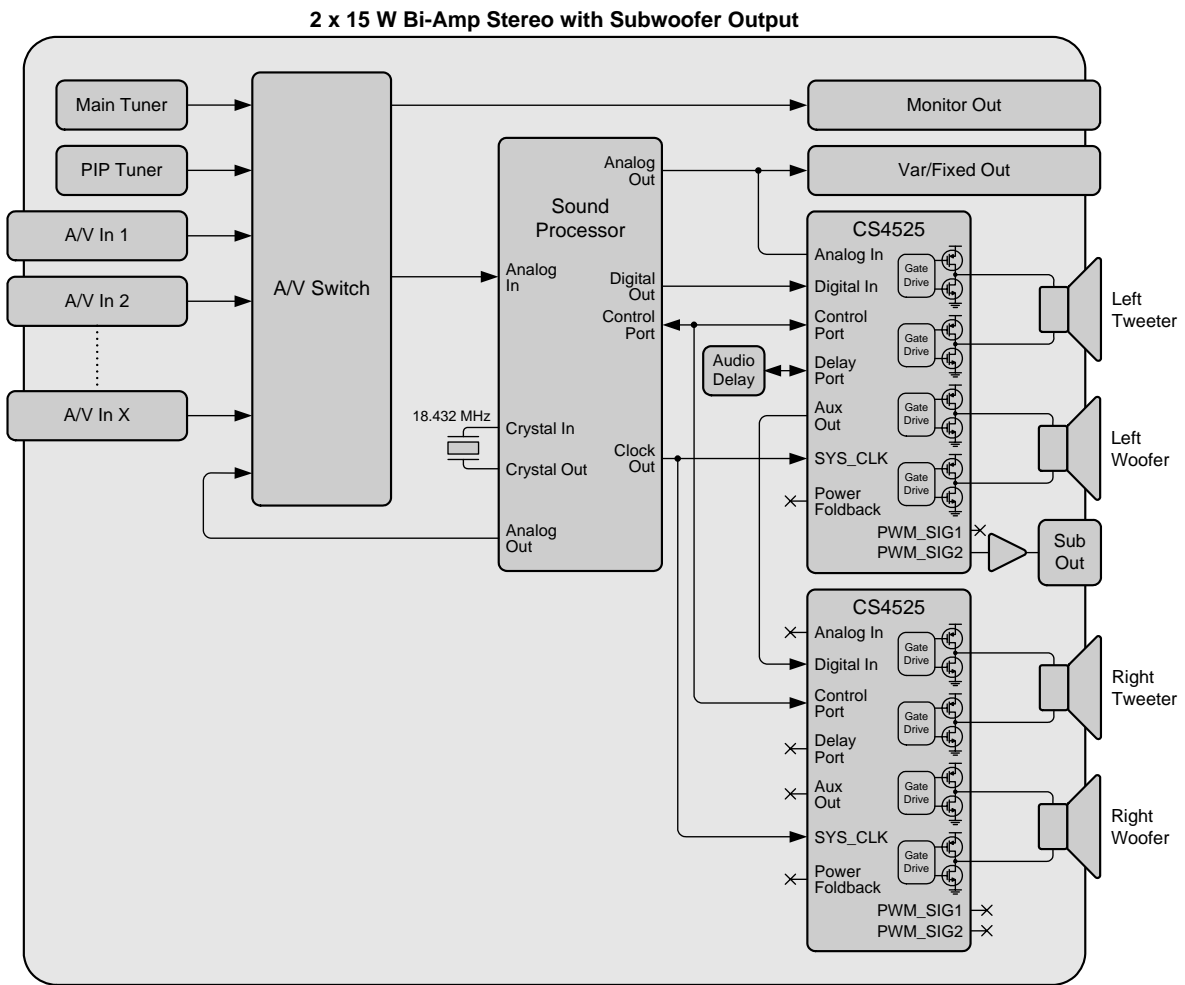

Figure 6. Typical System Configuration 4

5. CHARACTERISTICS AND SPECIFICATIONS

RECOMMENDED OPERATING CONDITIONS

AGND = DGND = PGND = 0 V; all voltages with respect to ground.

Parameters	Symbol	Min	Nom	Max	Units
DC Power Supply					
Digital and Analog Core (Note 1)	VD	2.375	2.5	2.625	V
	VD	3.135	3.3	3.465	V
	VD	4.75	5.0	5.25	V
Amplifier Outputs	VP	8.0	-	18.0	V
Temperature					
Ambient Temperature Commercial	T _A	-10	-	+70	°C
Junction Temperature	T _J	-10	-	+125	°C

Notes: 1. For VD = 2.5 V, VA_REG and VD_REG must be connected to VD. See [section 6.7 on page 63](#) for details.

ABSOLUTE MAXIMUM RATINGS

AGND = DGND = PGND = 0 V; all voltages with respect to ground.

Parameters	Symbol	Min	Max	Units
DC Power Supply				
Power Stage Outputs Switching and Under Load	VP	-0.3	19.8	V
Power Stage No Output Switching	VP	-0.3	23.0	V
Digital and Analog Core	VD	-0.3	6.0	V
Inputs				
Input Current (Note 2)	I _{in}	-	±10	mA
Analog Input Voltage (Note 3)	V _{INA}	AGND - 0.7	VA_REG + 0.7	V
Digital Input Voltage (Note 3)	V _{IND}	-0.3	VD + 0.4	V
Temperature				
Ambient Operating Temperature - Power Applied Commercial	T _A	-20	+85	°C
Storage Temperature	T _{stg}	-65	+150	°C

WARNING: Operation beyond these limits may result in permanent damage to the device. Normal operation is not guaranteed at these extremes.

Notes: 2. Any pin except supplies. Transient currents of up to ±100 mA on the analog input pins will not cause SCR latch-up.
3. The maximum over/under voltage is limited by the input current.

ANALOG INPUT CHARACTERISTICS

Test Conditions (unless otherwise specified): AGND = DGND = PGND = 0 V; All voltages with respect to ground; $T_A = 25^\circ\text{C}$; VD = 3.3 V; Input Signal: 1 kHz sine wave through the recommended passive input filter shown in [Figure 28 on page 61](#); Capacitor values connected to AFILTA, AFILTB, FILT+, VQ, VD_REG, and VA_REG as shown in [Figure 1 on page 13](#); Sample Frequency = 48 kHz; 10 Hz to 20 kHz Measurement Bandwidth; Power outputs in power-down state (PDnOut1 = 1, PDnOut2 = 1, PDnOut3/4 = 1).

Parameter		Min	Typ	Max	Unit
Dynamic Range (Note 4)	A-weighted	90	95	-	dB
	unweighted	87	92	-	dB
Total Harmonic Distortion + Noise	-1 dB	-	-86	-77	dB
	-20 dB	-	-72	-	dB
	-60 dB	-	-32	-	dB
DC Accuracy					
Interchannel Gain Mismatch		-	0.05	-	dB
Gain Drift		-	± 100	-	ppm/ $^\circ\text{C}$
Interchannel Isolation		-	90	-	dB
Full-scale Input Voltage	VD = 2.5V (Note 5)	$0.786 \cdot \text{VD}$	$0.827 \cdot \text{VD}$	$0.868 \cdot \text{VD}$	Vpp
	VD = 3.3V	$0.590 \cdot \text{VD}$	$0.621 \cdot \text{VD}$	$0.652 \cdot \text{VD}$	Vpp
	VD = 5.0V	$0.398 \cdot \text{VD}$	$0.419 \cdot \text{VD}$	$0.440 \cdot \text{VD}$	Vpp
Input Impedance	(Note 6)	40	-	-	k Ω

- Notes:**
4. Referred to the typical full-scale voltage
 5. For VD = 2.5 V, VA_REG and VD_REG must be connected to VD. See [section 6.7 on page 63](#) for details.
 6. Measured between AINx and AGND.

ADC DIGITAL FILTER CHARACTERISTICS

Parameter		Min	Typ	Max	Unit
Passband (Frequency Response) (Note 7)	to -0.1 dB corner	0	-	0.4948	Fs
Passband Ripple		-0.09	-	0	dB
Stopband	(Note 7)	0.6677	-	-	Fs
Stopband Attenuation		48.4	-	-	dB
Total Group Delay		-	$2.7/\text{Fs}$	-	s
High-Pass Filter Characteristics					
Frequency Response	-3.0 dB	-	3.7	-	Hz
	-0.13 dB	-	24.2	-	Hz
Phase Deviation	20 Hz	-	10	-	Deg
Passband Ripple		-	-	0.17	dB
Filter Settling Time		-	$10^5/\text{Fs}$	-	s

- Notes:**
7. Filter response is clock dependent and scales with the ADC sampling frequency (Fs). With a 27.000 MHz or 24.576 MHz XTAL/SYS_CLK, Fs is equal to the applied clock divided by 512. With an 18.432 MHz XTAL/SYS_CLK, Fs is equal to the applied clock divided by 384.

PWM POWER OUTPUT CHARACTERISTICS

Test Conditions (unless otherwise specified): AGND = DGND = PGND = 0 V; All voltages with respect to ground; $T_A = 25^\circ\text{C}$; $V_D = 3.3\text{ V}$; $V_P = 18\text{ V}$; $R_L = 8\ \Omega$ for full-bridge, $R_L = 4\ \Omega$ for half-bridge and parallel full-bridge; $\text{OutputDly}[3:0] = 1111$; $\text{PhaseShift} = 1$ for half-bridge, $\text{PhaseShift} = 0$ for full-bridge and parallel full-bridge; Input Signal: full-scale 997 Hz sine wave through serial audio input port, 48 kHz sample rate; Capacitor values connected to AFILTA, AFILTB, FILT+, VQ, VD_REG, and VA_REG as shown in [Figure 1 on page 13](#); PWM Switch Rate = 384 kHz; 10 Hz to 20 kHz Measurement Bandwidth; Performance measurements taken through AES17 filter.

Parameters	Symbol	Conditions	Min	Typ	Max	Units	
Power Output per Channel	Stereo Full-Bridge	THD+N < 10%	-	15	-	W	
		THD+N < 1%	-	12	-	W	
		Half-Bridge	THD+N < 10%	-	7	-	W
			THD+N < 1%	-	5.5	-	W
		Parallel Full-Bridge	THD+N < 10%	-	30	-	W
			THD+N < 1%	-	23.5	-	W
Total Harmonic Distortion + Noise	Stereo Full-Bridge	$P_O = 1\text{ W}$	-	0.05	-	%	
		$P_O = 0\text{ dBFS} = 11.3\text{ W}$	-	0.10	-	%	
	Half-Bridge	$P_O = 1\text{ W}$	-	0.12	-	%	
		$P_O = 0\text{ dBFS} = 5.0\text{ W}$	-	0.28	-	%	
	Parallel Full-Bridge	$P_O = 1\text{ W}$	-	0.1	-	%	
		$P_O = 0\text{ dBFS} = 22.6\text{ W}$	-	0.3	-	%	
Dynamic Range	Stereo Full-Bridge	$P_O = -60\text{ dBFS}$, A-Weighted	-	102	-	dB	
		$P_O = -60\text{ dBFS}$, Unweighted	-	99	-	dB	
	Half-Bridge	$P_O = -60\text{ dBFS}$, A-Weighted	-	99	-	dB	
		$P_O = -60\text{ dBFS}$, Unweighted	-	96	-	dB	
	Parallel Full-Bridge	$P_O = -60\text{ dBFS}$, A-Weighted	-	102	-	dB	
		$P_O = -60\text{ dBFS}$, Unweighted	-	99	-	dB	
MOSFET On Resistance	$R_{DS(ON)}$	$I_d = 0.5\text{ A}$, $T_J = 50^\circ\text{C}$	-	280	-	m Ω	
Efficiency	h	$P_O = 2 \times 15\text{ W}$, $R_L = 8\ \Omega$	-	85	-	%	
Minimum Output Pulse Width	PW_{min}	No Load	-	50	-	ns	
Rise Time of OUTx	t_r	Resistive Load	-	20	-	ns	
Fall Time of OUTx	t_f	Resistive Load	-	20	-	ns	
PWM Output Over-Current Error Trigger Point	I_{CE}	$T_A = 25^\circ\text{C}$, $OCREF = 16.2\text{ k}\Omega$	-	2.5	-	A	
		$T_A = 25^\circ\text{C}$, $OCREF = 18\text{ k}\Omega$	-	2.1	-	A	
		$T_A = 25^\circ\text{C}$, $OCREF = 22\text{ k}\Omega$	-	1.7	-	A	
Junction Thermal Warning Trigger Point	T_{TW}		-	105	-	$^\circ\text{C}$	
Junction Thermal Error Trigger Point	T_{TE}		-	125	-	$^\circ\text{C}$	
VP Under-Voltage Error Falling Trigger Point	V_{UVFALL}	$T_A = 25^\circ\text{C}$	-	4.7	4.9	V	
VP Under-Voltage Error Rising Trigger Point	V_{UVRISE}	$T_A = 25^\circ\text{C}$	-	4.95	5.4	V	

SERIAL AUDIO INPUT PORT SWITCHING SPECIFICATIONS

AGND = DGND = PGND = 0 V; $T_A = 25^\circ\text{C}$; $V_D = 3.3\text{ V}$; Inputs: Logic 0 = DGND; Logic 1 = V_D .

Parameters	Symbol	Min	Nominal	Max	Units
Supported Input Sample Rates	F_{SI}	28.5	32	35.2	kHz
		39.5	44.1	52.8	
		39.5	48	52.8	
		86.4	96	105.6	
LRCK Duty Cycle		45	-	55	%
SCLK Frequency	(Note 8),(Note 9) $1/t_p$	$F_{SI} * 2 * N_{bits}$	-	$F_{CLK}/3$	Hz
SCLK Duty Cycle		45	-	55	%
LRCK Setup Time Before SCLK Rising Edge	$t_{s(LK-SK)}$	40	-	-	ns
SDIN Setup Time Before SCLK Rising Edge	$t_{s(SD-SK)}$	25	-	-	ns
SDIN Hold Time After SCLK Rising Edge	t_h	10	-	-	ns
RST pin Low Pulse Width	(Note 10)	1	-	-	ms

- Notes:**
8. F_{CLK} is the frequency of the crystal connected to the XTI/XTO pins or the input SYS_CLK signal.
 9. N_{bits} is the number of bits per sample of the serial digital input.
 10. After powering up the CS4525, \overline{RST} should be held low until the power supplies and clocks are stable.

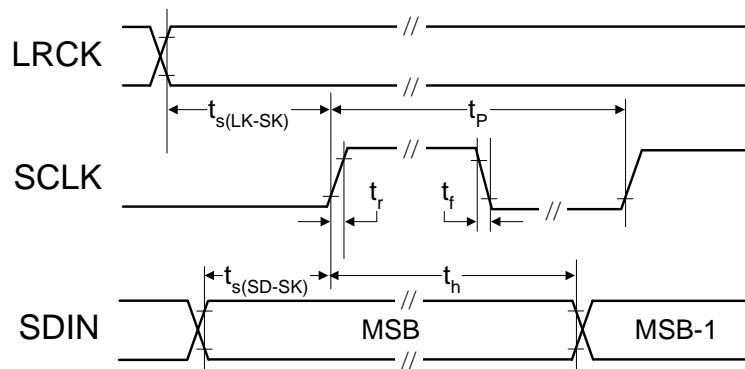

Figure 7. Serial Audio Input Port Timing

AUX SERIAL AUDIO I/O PORT SWITCHING SPECIFICATIONS

AGND = DGND = PGND = 0 V; $T_A = 25^\circ\text{C}$; $V_D = 3.3\text{ V}$; AUX_SDOUT & DLY_SDOUT $C_L = 15\text{ pF}$; Inputs: Logic 0 = DGND; Logic 1 = VD; (Note 11).

Parameters	Symbol	Min	Typ	Max	Units
Input Source: Analog Inputs (Internal ADC)					
Output Sample Rate	ClkFreq[1:0] = '00'	-	$F_{CLK}/384$	-	Hz
	ClkFreq[1:0] = '01'	-	$F_{CLK}/512$	-	Hz
	ClkFreq[1:0] = '10'	-	$F_{CLK}/512$	-	Hz
AUX_LRCK Duty Cycle		-	50	-	%
AUX_LRCK Period		-	$1/F_{SO}$	-	s
AUX_SCLK Frequency	ClkFreq[1:0] = '00'	-	$48 * F_{SO}$	-	Hz
	ClkFreq[1:0] = '01'	-	$64 * F_{SO}$	-	Hz
	ClkFreq[1:0] = '10'	-	$64 * F_{SO}$	-	Hz
AUX_SCLK Duty Cycle		-	50	-	%
AUX_SCLK Period		-	$1/F_{SCLKO}$	-	s
Input Source: Serial Audio Input Port					
Output Sample Rate	$F_{S-In} = 32\text{ kHz}, 44.1\text{ kHz}, 48\text{ kHz}$	F_{SO}	F_{SI}	-	Hz
	$F_{S-In} = 96\text{ kHz}$		$F_{SI}/2$	-	Hz
AUX_LRCK Duty Cycle	(Note 13)	45	-	55	%
AUX_LRCK Period	(Note 12, 13)	$T_{SI} - T_{CLK}$	T_{SI}	$T_{SI} + T_{CLK}$	s
AUX_SCLK Frequency	$F_{S-In} = 32\text{ kHz}, 44.1\text{ kHz}, 48\text{ kHz}$	-	F_{SCLKI}	-	Hz
	$F_{S-In} = 96\text{ kHz}$	-	$F_{SCLKI}/2$	-	Hz
AUX_SCLK Duty Cycle		30	-	70	%
AUX_SCLK Period	$F_{S-In} = 32\text{ kHz}, 44.1\text{ kHz}, 48\text{ kHz}$	$T_{SCLKI} - T_{CLK}$	T_{SCLKI}	$T_{SCLKI} + T_{CLK}$	s
	$F_{S-In} = 96\text{ kHz}$	$2 * T_{SCLKI} - T_{CLK}$	$2 * T_{SCLKI}$	$2 * T_{SCLKI} + T_{CLK}$	s
Input Source: Analog Inputs or Serial Audio Input Port					
AUX_LRCK Rising Edge to AUX_SCLK Falling Edge	t_{LTSF}	-	-	20	ns
AUX_SCLK Rising Edge to Data Output Valid	t_{SRDV}	-	-	$T_{CLK} + 20$	ns
DLY_SDIN Setup Time Before AUX_SCLK Rising Edge	t_{DIS}	25	-	-	ns
DLY_SDIN Hold Time After AUX_SCLK Rising Edge	t_{DIH}	10	-	-	ns

- Notes:**
- F_{CLK} is the frequency of the crystal connected to the XT1/XTO pins or the input SYS_CLK signal.
 $T_{CLK} = 1/F_{CLK}$.
 - F_{SI} is the frequency of the input LRCK signal. $T_{SI} = 1/F_{SI}$
 - May vary during normal operation.
 - F_{SCLKI} is the frequency of the input SCLK signal. $T_{SCLKI} = 1/F_{SCLKI}$.

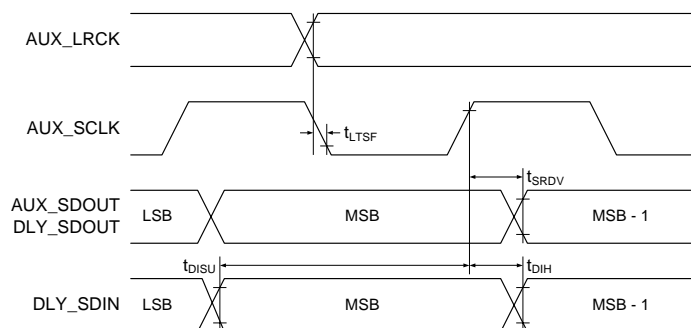

Figure 8. AUX Serial Port Interface Master Mode Timing

XTI SWITCHING SPECIFICATIONS

Parameter	Symbol	Min	Typ	Max	Unit	
External Crystal Operating Frequency (Note 15)	F_{CLK}	ClkFreq[1:0] = '00'	18.240	18.432	18.617	MHz
		ClkFreq[1:0] = '01'	24.330	24.576	24.822	MHz
		ClkFreq[1:0] = '10'	26.730	27.000	27.270	MHz
XTI Duty Cycle		45	50	55	%	

Notes: 15. See “Clock Frequency (ClkFreq[1:0])” on page 69.

SYS_CLK SWITCHING SPECIFICATIONS

AGND = DGND = PGND = 0 V; $T_A = 25^\circ\text{C}$; VD = 3.3 V; Input: Logic 0 = DGND; Logic 1 = VD, SYS_CLK Output: $C_L = 20$ pF.

Parameter	Symbol	Min	Typ	Max	Unit	
External Clock Operating Frequency (Note 15)	F_{CLK}	ClkFreq[1:0] = '00'	18.240	18.432	18.617	MHz
		ClkFreq[1:0] = '01'	24.330	24.576	24.822	MHz
		ClkFreq[1:0] = '10'	26.730	27.000	27.270	MHz
Rising Edge \overline{RST} to start of SYS_CLK	t_{sclko}	-	$1024 \cdot t_{sclki}$	-		
SYS_CLK Period	t_{sclki}	37.04	-	54.25	ns	
SYS_CLK Duty Cycle		45	50	55	%	
SYS_CLK high time	t_{clkih}	16.67	-	29.84	ns	
SYS_CLK low time	t_{clkil}	16.67	-	29.84	ns	

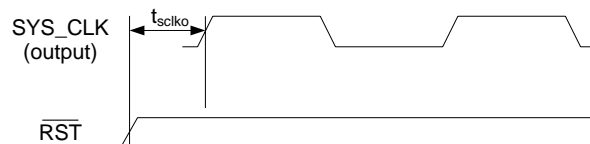

Figure 9. SYS_CLK Timing from Reset

PWM_SIGX SWITCHING SPECIFICATIONS

AGND = DGND = PGND = 0 V; $T_A = 25^\circ\text{C}$; VD = 3.3 V; Load = 10 pF.

Parameter	Symbol	Min	Typ	Max	Unit
Rise Time of PWM_SIGx	t_r	-	2.1	-	ns
Fall Time of PWM_SIGx	t_f	-	1.4	-	ns

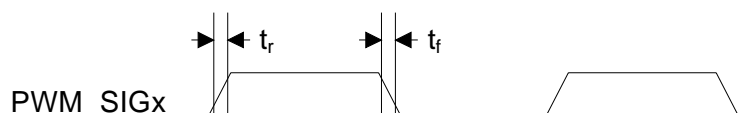

Figure 10. PWM_SIGX Timing

I²C CONTROL PORT SWITCHING SPECIFICATIONS

AGND = DGND = PGND = 0 V; T_A = 25°C; V_D = 3.3 V; Inputs: Logic 0 = DGND; Logic 1 = V_D; SDA C_L = 30 pF.

Parameter	Symbol	Min	Max	Unit
SCL Clock Frequency	f _{scl}	-	100	kHz
RST Rising Edge to Start	t _{irs}	500	-	ns
Bus Free Time Between Transmissions	t _{buf}	4.7	-	μs
Start Condition Hold Time (prior to first clock pulse)	t _{hdst}	4.0	-	μs
Clock Low time	t _{low}	4.7	-	μs
Clock High Time	t _{high}	4.0	-	μs
Setup Time for Repeated Start Condition	t _{sust}	4.7	-	μs
SDA Hold Time from SCL Falling (Note 16)	t _{hdd}	10	-	ns
SDA Setup time to SCL Rising	t _{sud}	250	-	ns
Rise Time of SCL and SDA	t _{rc}	-	1	μs
Fall Time SCL and SDA	t _{fc}	-	300	ns
Setup Time for Stop Condition	t _{susp}	4.7	-	μs
Acknowledge Delay from SCL Falling	t _{ack}	300	1000	ns

Notes: 16. Data must be held for sufficient time to bridge the transition time, t_{fc}, of SCL.

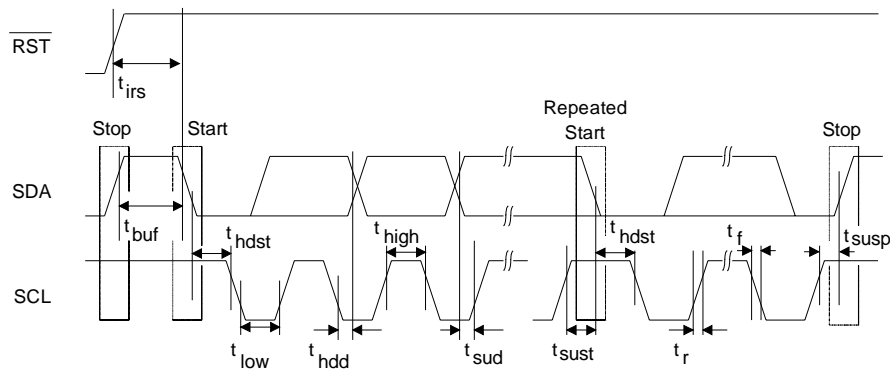

Figure 11. Control Port Timing - I²C

DC ELECTRICAL CHARACTERISTICS

AGND = DGND = PGND = 0 V; All voltages with respect to ground; PWM switch rate = 384 kHz; Unless otherwise specified.

Parameters		Min	Typ	Max	Units
Normal Operation (Note 17)					
Power Supply Current	VD = 3.3 V	-	54	-	mA
Power Dissipation	VD = 3.3 V	-	180	-	mW
Power-Down Mode (Note 18)					
Power Supply Current	VD = 3.3 V	-	2.8	-	mA
VD_REG Characteristics					
Nominal Voltage		2.25	2.5	2.75	V
DC current source		-	-	3	mA
VA_REG Characteristics					
Nominal Voltage		2.25	2.5	2.75	V
DC current source		-	-	1	mA
VQ Characteristics					
Nominal Voltage		-	0.5*VA_REG	-	V
Output Impedance		-	23	-	kΩ
DC current source/sink	(Note 19)	-	-	10	μA
Filt+ Nominal Voltage		-	VA_REG	-	V
Power Supply Rejection Ratio (Note 20)	1 kHz	-	60	-	dB
	60 Hz	-	40	-	dB

- Notes:**
- Normal operation is defined as $\overline{RST} = HI$.
 - Power-Down Mode is defined as $\overline{RST} = LOW$ with all input lines held static.
 - The DC current drain represents the allowed current from the VQ pin due to typical leakage through the electrolytic de-coupling capacitors.
 - Valid with the recommended capacitor values on FILT+ and VQ. Increasing the capacitance will increase the PSRR.

DIGITAL INTERFACE SPECIFICATIONS

AGND = DGND = PGND = 0 V; All voltages with respect to ground; Unless otherwise specified.

Parameters		Symbol	Min	Max	Units
Digital Interface Signal Characteristics (Note 21)					
High-Level Input Voltage		V _{IH}	0.75*VD_REG	-	V
Low-Level Input Voltage		V _{IL}	-	0.20*VD_REG	V
High-Level Output Voltage	I _o =2 mA	V _{OH}	0.90*VD	-	V
Low-Level Output Voltage	I _o =2 mA	V _{OL}	-	0.2	V
Input Leakage Current		I _{in}	-	±10	uA
Input Capacitance			-	8	pF
PWM_SIGx Characteristics					
High-Level PWM_SIGx Output Voltage	I _o =2 mA	V _{OHPS}	0.90*VD_REG	-	V
Low-Level PWM_SIGx Output Voltage	I _o =2 mA	V _{OLPS}	-	0.2	V

- Notes:**
- Digital interface signals include all pins sourced from the VD supply as shown in “Digital I/O Pin Characteristics” on page 12.

6. APPLICATIONS

6.1 Software Mode

Maximum device flexibility and features are available when the CS4525 is used in software mode. The available features are described in the following sections. All device configuration is achieved via the I²C control port as described in the [I²C Control Port Description and Timing](#) section on [page 64](#).

6.1.1 System Clocking

In software mode, the CS4525 can be clocked by a stable external clock source input on the SYS_CLK pin or by a clock internally generated through the use of its internal oscillator driver circuit in conjunction with an external crystal oscillator. The device automatically selects which of these clocks to use within 10 ms of the release of \overline{RST} .

The internal clock is used to synchronize the input serial audio signals with the internal clock domain and to clock the internal digital processing, sample-rate converter, and PWM modulators. It is also used to determine the sample rate of the serial audio input signals in order to automatically configure the various internal filter coefficients.

To ensure proper operation, the CS4525 must be informed of the nominal frequency of the supplied SYS_CLK signal or the attached crystal via the ClkFreq[1:0] bits in the Clock Config register. These bits must be set to the appropriate value before the PDnAll bit is cleared to initiate a power-up sequence. See the [SYS_CLK Switching Specifications](#) and [XTI Switching Specifications](#) tables on [page 23](#) for complete input frequency range specifications.

WARNING: The system clock source must never be removed or stopped while any of the power output stages are powered-up (the PDnAll bit and any of the PDnOut1, PDnOut2, or PDnOut3/4 bits are cleared) and connected to a load. Doing so may result in permanent damage to the CS4525 and connected transducers.

Referenced Control	Register Location
ClkFreq[1:0].....	"Clock Frequency (ClkFreq[1:0])" on page 69
PDnAll.....	"Power Down (PDnAll)" on page 89
PDnOutX.....	"Power Down PWM Power Output X (PDnOutX)" on page 88

6.1.1.1 SYS_CLK Input Clock Mode

If an input clock is detected on the SYS_CLK pin following the release of \overline{RST} , the device will automatically use the SYS_CLK input as its clock source. The applied SYS_CLK clock signal must oscillate within the frequency ranges specified in the SYS_CLK switching specifications table on [page 23](#). In this mode, XTI should be connected to ground and XTO should be left unconnected.

Figure 12 below demonstrates a typical clocking configuration using the SYS_CLK input.

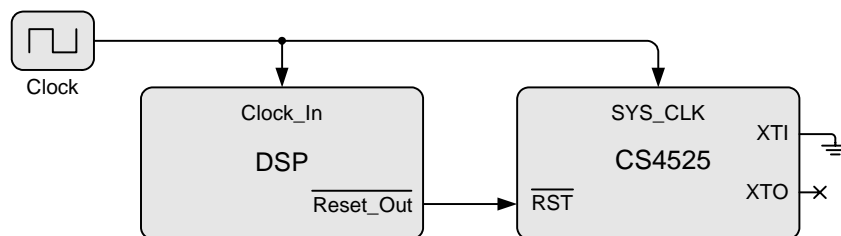

Figure 12. Typical SYS_CLK Input Clocking Configuration

6.1.1.2 Crystal Oscillator Mode

To use an external crystal in conjunction with the internal crystal driver, a 20 pF fundamental mode parallel resonant crystal must be connected between the XTI and XTO pins. This crystal must oscillate within the frequency ranges specified in the XTI switching specifications table on [page 23](#). Nothing other than the crystal and its load capacitors should be connected to XTI and XTO. The SYS_CLK pin should be connected to ground through a 22 kΩ pull-down resistor to prevent the CS4525 from recognizing system noise on the SYS_CLK pin as a valid clocking signal.

In this mode, the CS4525 will automatically drive the generated internal clock out of the SYS_CLK pin. This can be disabled with the EnSysClk bit which will cause the SYS_CLK pin to become high-impedance. Also, the DivSysClk bit allows the frequency of the generated internal clock to be divided by 2 prior to being driven out of the SYS_CLK.

It should be noted that the internal oscillator driver is disabled when the CS4525 is in reset (\overline{RST} is low). Any external devices connected to the SYS_CLK output will not receive a clock signal until the CS4525 is taken out of reset.

If an external crystal is connected to the XTI/XTO pins while an input clock signal is present on the SYS_CLK pin following the release of \overline{RST} , then the CS4525 will automatically use the SYS_CLK pin for its internal clock. Refer to [Section 6.1.1.1](#) for a details about this mode of operation.

[Figure 13](#) below demonstrates a typical clocking configuration using the crystal oscillator.

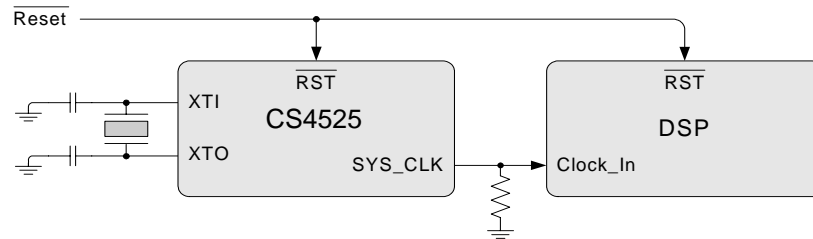

Figure 13. Typical Crystal Oscillator Clocking Configuration

Referenced Control	Register Location
EnSysClk.....	“SYS_CLK Output Enable (EnSysClk)” on page 69
DivSysClk.....	“SYS_CLK Output Divider (DivSysClk)” on page 69

6.1.2 Power-Up and Power-Down

The CS4525 will remain in a completely powered-down state with the control port inaccessible until the $\overline{\text{RST}}$ pin is brought high. Once $\overline{\text{RST}}$ is high, the control port will be accessible, but all other internal blocks will remain powered-down until they are powered-up via the control port or until hardware mode is entered.

When an external crystal is present on the XTI/XTO pins, software mode will be automatically entered 10 ms after the release of $\overline{\text{RST}}$. If SYS_CLK is used as an input, software mode is entered by writing to the control port within 10 ms after the release of $\overline{\text{RST}}$. If the control port is not written within this time, the device will begin to operate in hardware mode.

6.1.2.1 Recommended Power-Up Sequence

1. Hold $\overline{\text{RST}}$ low until the power supplies and the input SYS_CLK (if used) are stable.
2. Bring $\overline{\text{RST}}$ high.
The device will remain in a low-power state and the control port will be accessible. The device will automatically enter software mode after 10 ms if an external crystal is present on the XTI/XTO pins, at which time the output SYS_CLK signal will become active.
3. If SYS_CLK is used as an input, initiate a control port write to set the PDnAll bit in register 5Fh within 10 ms following the release of $\overline{\text{RST}}$.
This operation causes the device to enter software mode and places it in power-down mode.
4. If the LVD pin is tied low and VD, VD_REG, and VA_REG are connected to 2.5 V, clear the SelectVD bit in the Power Ctrl register to indicate the 2.5 V VD supply level. See [section 6.7 on page 63](#) for details.
5. If VP is connected to a supply voltage less than or equal to 14 V nominal, clear the SelectVP bit in the Foldback Cfg register to indicate the VP supply level.
6. The desired register settings can be loaded while keeping the PDnAll bit set. Typical initialization settings include Input Configuration, Output Configuration, Master Volume, and Clock Frequency.
7. Clear the PDnAll bit to initiate the power-up sequence.

6.1.2.2 Recommended Power-Down Sequence

1. Set the MuteChA, MuteChB, and MuteSub bits in the Mute Control register to mute the audio output.
2. Set the PDnAll bit to power-down the device.
3. Bring $\overline{\text{RST}}$ low to bring the device's power consumption to an absolute minimum.
4. Remove power.

Referenced Control	Register Location
PDnAll	"Power Down (PDnAll)" on page 89
SelectVD	"Select VD Level (SelectVD)" on page 88
SelectVP	"Select VP Level (SelectVP)" on page 74
MuteChX	"Independent Channel A & B Mute (MuteChX)" on page 84
MuteSub	"Sub Channel Mute (MuteSub)" on page 85
Input Configuration	"Input Configuration (Address 02h)" on page 71
Output Configuration	"Output Configuration (Address 04h)" on page 73
Master Volume	"Master Volume Control (Address 57h)" on page 82
Clock Frequency	"Clock Frequency (ClkFreq[1:0])" on page 69

6.1.3 Input Source Selection

The CS4525 can accept analog or digital audio input signals. Digital audio input signals are supplied through the serial audio input port as outlined in “[Serial Audio Interfaces](#)” on page 62. Analog audio input signals are supplied through the internal ADC as outlined in “[Analog Inputs](#)” on page 61. The input source is selected by the ADC/SP bit in the Input Config register.

In software mode, the serial audio input port supports I²S, Left-Justified and Right-Justified data formats. The serial audio input port digital interface format is configured by the DIF[2:0] bits in the Input Config register.

The CS4525 internal ADC includes a dedicated high-pass filter to remove any DC content from the ADC output signal prior to the internal ADC/serial audio input port input multiplexor. This high-pass filter can be bypassed by clearing the EnAnHPF bit.

Referenced Control	Register Location
ADC/SP	“ Input Source Selection (ADC/SP) ” on page 71
DIF[2:0]	“ Input Serial Port Digital Interface Format (DIF [2:0]) ” on page 71
EnAnHPF	“ ADC High-Pass Filter Enable (EnAnHPF) ” on page 71

6.1.4 Digital Sound Processing

The CS4525 implements flexible digital sound processing operations including bass management crossover, 2-way speaker crossovers, high- and low-pass shelving filters, programmable parametric EQ filters, adaptive loudness compensation, channel mixers, and volume controls.

The digital signal flow is shown in [Figure 14](#) below. The signal processing blocks are described in detail in the following sections.

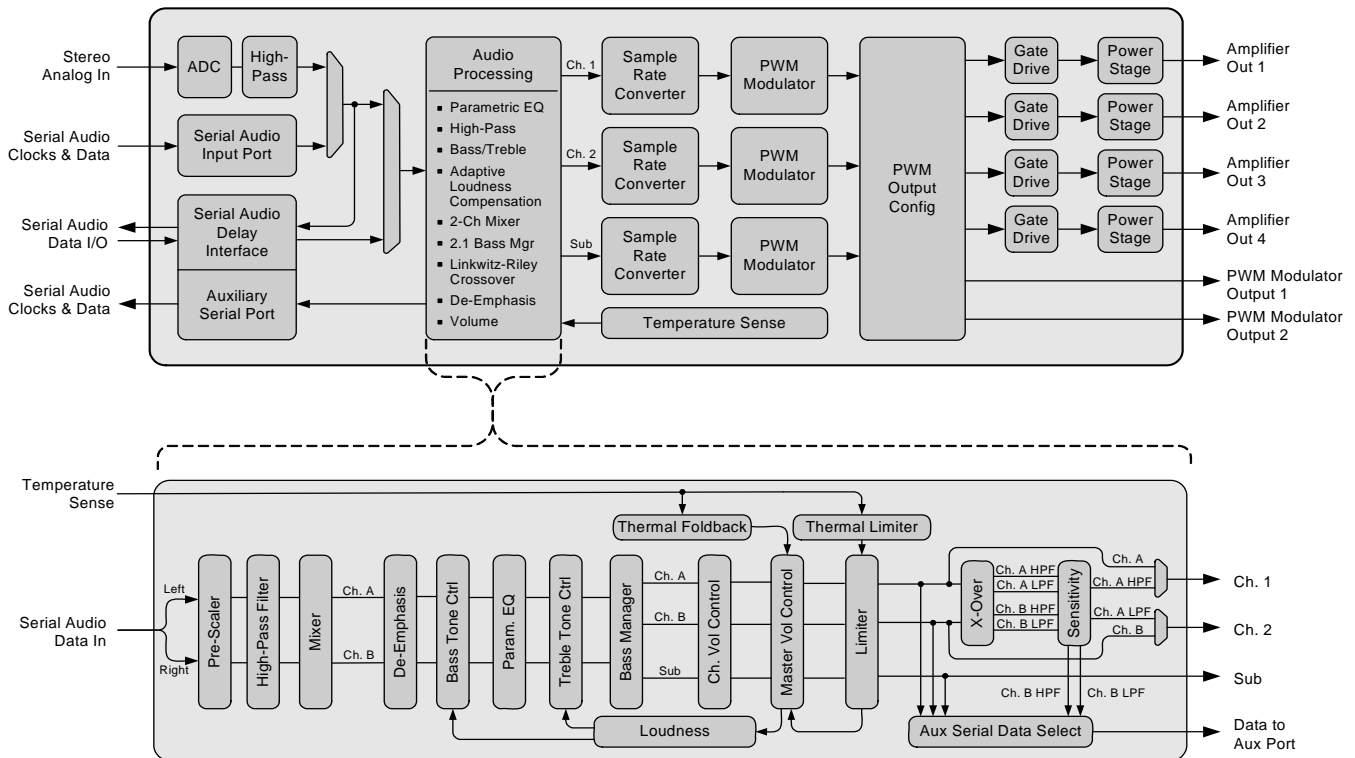

Figure 14. Digital Signal Flow

6.1.4.1 Pre-Scaler

Applying any gain to a full-scale signal in the digital domain will cause the signal to clip. To prevent this, a pre-scaler block is included prior to the internal digital signal processing blocks. This allows the input signal to be attenuated before processing to ensure that any signal boosting, such as gain in a shelving filter, will not cause a channel to clip.

The pre-scaler block allows up to -14.0 dB of attenuation in 2.0 dB increments and is controlled with the PreScale[2:0] bits.

Referenced Control	Register Location
PreScale[2:0].....	"Pre-Scale Attenuation (PreScale[2:0])" on page 75

6.1.4.2 Digital Signal Processing High-Pass Filter

The CS4525 includes a high-pass filter at the beginning of the digital signal processing chain to remove any DC content from the input signal prior to the remaining internal digital signal processing blocks. The high-pass filter operates by continuously subtracting a measure of the DC offset from the input signal and may be used regardless of the input data source.

The digital signal processing high-pass filter can be disabled by clearing the EnDigHPF bit.

Referenced Control	Register Location
EnDigHPF	"Digital Signal Processing High-Pass Filter (EnDigHPF)" on page 77

6.1.4.3 Channel Mixer

The CS4525 implements independent channel mixers to provide for both mono mixes and channel swaps for the left and right channels. The channel mixers are controlled by the LChMix[1:0] and RChMix[1:0] bits in the Mixer Config register.

To allow stereo operation when a mono mix is configured, when the HP_DETECT/MUTE pin is configured for headphone detection (the HP/Mute bit is set), the operation of the left channel mixer is affected by the active state of the headphone detection input signal. In this configuration, when the left channel mixer is configured for a mono mix (LChMix[1:0] = 01 or 10) and the headphone detection input signal becomes active, the left channel mixer will be automatically reconfigured to output the left channel, thereby disabling the mono mix. When the headphone detection input signal becomes inactive, the mixer will be automatically reconfigured to operate as dictated by the LChMix[1:0] bits.

It should be noted that the right channel mixer output is unaffected by the headphone detection input signal and will always operate as dictated by the RChMix[1:0] bits.

Referenced Control	Register Location
LChMix[1:0]	"Left Channel Mixer (LChMix[1:0])" on page 76
RChMix[1:0]	"Right Channel Mixer (RChMix[1:0])" on page 76
HP/Mute	"HP_Detect/Mute Pin Mode (HP/Mute)" on page 70

6.1.4.4 De-Emphasis

The CS4525 includes an on-chip digital de-emphasis filter optimized for a sample rate of 44.1 kHz to accommodate audio recordings that utilize 50/15 μ s pre-emphasis equalization as a means of noise reduction. The filter response is shown in Figure 15. The de-emphasis filter is enabled and disabled by the DeEmph bit in the Tone Config register.

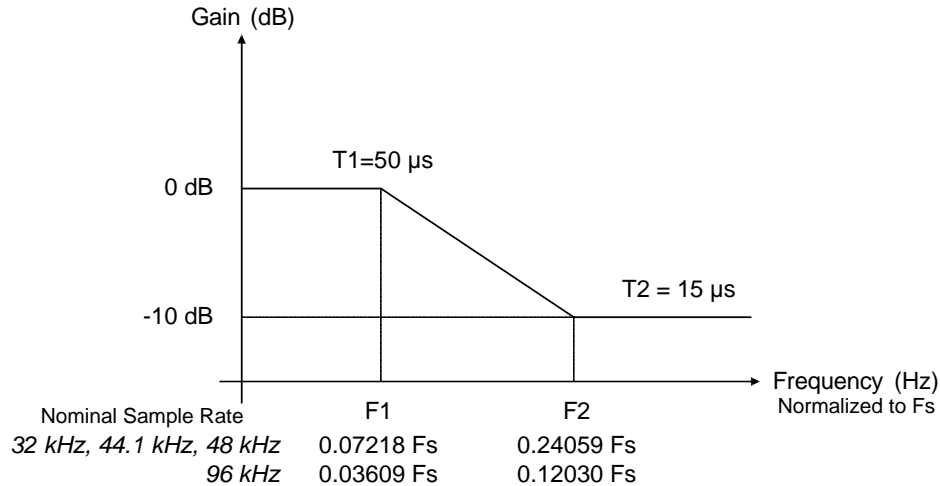

Figure 15. De-Emphasis Filter

Referenced Control	Register Location
DeEmph	"De-Emphasis Control (DeEmph)" on page 76

6.1.4.5 Tone Control

The CS4525 implements configurable bass and treble shelving filters to easily accommodate system tone control requirements. Each shelving filter has 4 selectable corner frequencies, and provides a cut/boost range from -10.5 dB to +12.0 dB in 1.5 dB increments. The tone control is enabled by the EnToneCtrl bit in the Tone Config register.

Each tone control is implemented with one of two preset internal filter sets. One set is optimized for a 32 kHz sample rate, and the other is optimized for 44.1 kHz, 48 kHz, and 96 kHz sample rates. The CS4525 automatically detects the input sample rate and chooses the appropriate filter set to apply. The available corner frequencies are shown in tables 2 and 3 below and are configured with the BassFc[1:0] and TrebFc[1:0] bits in the Tone Config register.

Note that the corner frequency of each filter set scales linearly with the input sample rate.

When the internal ADC is used as the serial audio data source, the input sample rate is nominally 48 kHz and the corresponding shelving frequency corners are available.

Input Sample Rate	Bass Fc 0	Bass Fc 1	Bass Fc 2	Bass Fc 3
32 kHz	50 Hz	100 Hz	200 Hz	250 Hz
44.1 kHz	48 Hz	96 Hz	192 Hz	240 Hz
48 kHz, 96 kHz	52 Hz	104 Hz	208 Hz	260 Hz

Table 2. Bass Shelving Filter Corner Frequencies

Input Sample Rate	Treble Fc 0	Treble Fc 1	Treble Fc 2	Treble Fc 3
32 kHz	5.0 kHz	7.0 kHz	10.0 kHz	15.0 kHz
44.1 kHz	4.8 kHz	6.7 kHz	9.6 kHz	14.4 kHz
48 kHz, 96 kHz	5.2 kHz	7.3 kHz	10.4 kHz	15.6 kHz

Table 3. Treble Shelving Filter Corner Frequencies

The cut/boost level of the bass and treble shelving filters are set by the Bass[3:0] and Treble[3:0] bits in the Tone Control register.

Referenced Control	Register Location
EnToneCtrl	"Tone Control Enable (EnToneCtrl)" on page 77
TrebFc[1:0]	"Treble Corner Frequency (TrebFc[1:0])" on page 77
BassFc[1:0]	"Bass Corner Frequency (BassFc[1:0])" on page 77
Treble[3:0]	"Treble Gain Level (Treb[3:0])" on page 78
Bass[3:0]	"Bass Gain Level (Bass[3:0])" on page 78

6.1.4.6 Parametric EQ

The CS4525 implements 5 fully programmable parametric EQ filters.

The filters are implemented in the bi-quad form shown below.

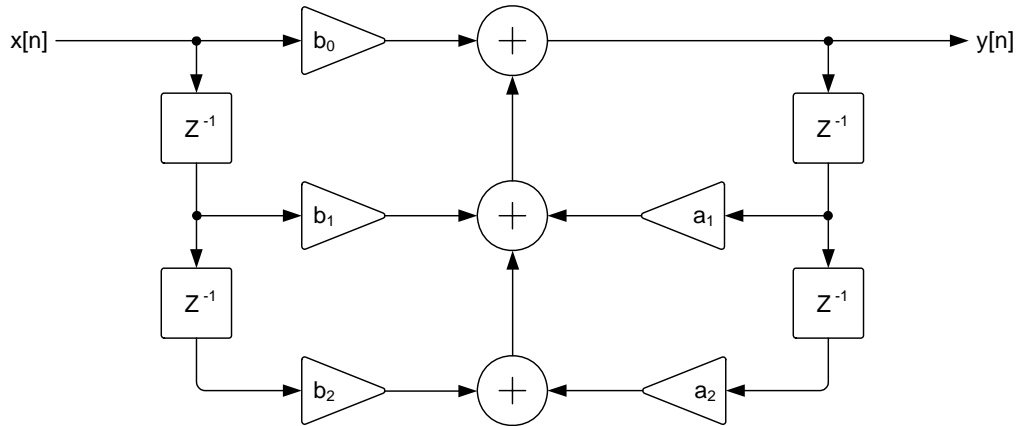

Figure 16. Bi-Quad Filter Architecture

This architecture is represented by the equation shown below where $y[n]$ represents the output sample value and $x[n]$ represents the input sample value.

$$y[n] = b_0x[n] + b_1x[n-1] + b_2x[n-2] + a_1y[n-1] + a_2y[n-2]$$

Equation 1. Bi-Quad Filter Equation

The coefficients are represented in binary form by 24-bit signed values stored in 3.21 two's complement format. The 3 MSB's represent the sign bit and the whole-number portion of the decimal coefficient, and the 21 LSB's represent the fractional portion of the decimal coefficient. The coefficient values must be in the range of -4.00000 decimal (80 00 00 hex) to 3.99996 decimal (7F FF FF hex).

The binary coefficient values are stored in registers 0Ah - 54h. Each 24-bit coefficient is split into 3 bytes, each of which is mapped to an individually accessible register location. See the ["Register Quick Reference" section beginning on page 66](#) for the specific register locations for each coefficient.

By default, all b_0 coefficients are set to 1 decimal, and all other coefficients are set to 0 decimal. This implements a pass-through function.

The parametric equalizers be independently enabled and disabled for channels A and B with the EnChAPEq and EnChBPEq bits located in the EQ Config register.

Referenced Control	Register Location
EnChAPEq	"Enable Channel A Parametric EQ (EnChAPEq)" on page 79
EnChBPEq	"Enable Channel B Parametric EQ (EnChBPEq)" on page 79

6.1.4.7 Adaptive Loudness Compensation

The CS4525 includes adaptive loudness compensation to enhance the audibility of program material at low volume levels. The adaptive loudness compensation feature operates by varying the bass and treble boost of the tone control shelving filters as the volume level changes.

The level of boost added to the shelving filters is determined by the average of the effective volume settings of channels A and B after the master volume control. As this average volume setting decreases from 0 dB, the boost of the bass and treble shelving filters is gradually increased until it reaches the maximum boost level of 12.0 dB. As the volume is increased, the boost applied due to the adaptive loudness compensation feature will be gradually removed until it reaches the level specified by the Treble[3:0] and Bass[3:0] bits in the Tone Control register.

The adaptive loudness compensation feature is enabled by setting the Loudness bit in the Tone Config register. When the loudness feature is enabled, it immediately evaluates the effective average volume and applies bass and treble boost accordingly. When disabled, any treble or bass boost applied due to the loudness feature will be removed.

Because the adaptive loudness compensation filter operates by adjusting the boost level of the tone control shelving filters, it is necessary that they be enabled with the EnToneCtrl bit in the Tone Config register in order for the loudness feature to be operational. If the tone control filters are disabled, the adaptive loudness compensation feature will not be functional.

Referenced Control	Register Location
Loudness.....	"Adaptive Loudness Compensation Control (Loudness)" on page 76
EnToneCtrl	"Tone Control Enable (EnToneCtrl)" on page 77
TrebFc[1:0]	"Treble Corner Frequency (TrebFc[1:0])" on page 77
BassFc[1:0]	"Bass Corner Frequency (BassFc[1:0])" on page 77
Treble[3:0]	"Treble Gain Level (Treb[3:0])" on page 78
Bass[3:0]	"Bass Gain Level (Bass[3:0])" on page 78

6.1.4.8 Bass Management

The CS4525 implements a dedicated stereo 24 dB/octave Linkwitz-Riley crossover with adjustable cross-over frequency to achieve bass management for 2.1 configurations. The filter's stereo high-pass outputs are used to drive the full-range speakers, and its stereo low-pass outputs are each attenuated by 6 dB and summed to drive the sub channel.

The bass management crossover is implemented with one of two preset internal filter sets. One set is optimized for a 32 kHz sample rate, and the other is optimized for 44.1 kHz, 48 kHz, and 96 kHz sample rates. The CS4525 automatically detects the input sample rate and chooses the appropriate filter set to apply. The available bass management cross-over frequencies are shown in [Table 4](#) below and are configured with the BassMgr[2:0] bits in the EQ Config register.

Note that the corner frequency of each filter set scales linearly with the input sample rate.

When the internal ADC is used as the serial audio data source, the input sample rate is nominally 48 kHz and the corresponding shelving frequency corners are available.

	Input Sample Rate		
	32 kHz	44.1 kHz	48 kHz, 96 kHz
Bass Manager Freq 1	80 Hz	77 Hz	83 Hz
Bass Manager Freq 2	120 Hz	115 Hz	125 Hz
Bass Manager Freq 3	160 Hz	153 Hz	167 Hz
Bass Manager Freq 4	200 Hz	192 Hz	209 Hz
Bass Manager Freq 5	240 Hz	230 Hz	250 Hz
Bass Manager Freq 6	280 Hz	268 Hz	292 Hz
Bass Manager Freq 7	320 Hz	307 Hz	334 Hz

Table 4. Bass Management Cross-Over Frequencies

The BassMgr[2:0] bits also allow the bass manager to be disabled. When disabled, the bass management crossover is bypassed and no signal is presented on the sub channel.

To allow full-range headphone operation, when the HP_DETECT/MUTE pin is configured for headphone detection (the HP/Mute bit is set), the operation of the bass manager is affected by the active state of the headphone detection input signal. In this configuration, when the bass manager is enabled, (BassMgr[2:0] bits not equal to '000') and the headphone detection input signal becomes active, the bass manager will be automatically disabled. When the headphone detection input signal becomes inactive, the bass manager will be automatically reconfigured to operate as dictated by the BassMgr[2:0] bits.

Referenced Control	Register Location
BassMgr[2:0]	"Bass Cross-Over Frequency (BassMgr[2:0])" on page 79
HP/Mute	"HP_Detect/Mute Pin Mode (HP/Mute)" on page 70

6.1.4.9 Volume and Muting Control

The CS4525's volume control architecture provides the ability to control the level of each output channel on both an individual and master basis.

Individual control allows the volume and mute state of a single channel to be changed independently from the other channels within the device. The CS4525 provides three individual volume and muting controls, each permanently assigned to one channel within the device. The three individual volume controls, ChAVol, ChBVol, and SubVol, can gain or attenuate channel A, channel B, or the sub channel (respectively) from +24 dB to -103 dB in 0.5 dB steps. The three individual mute controls, MuteChA, MuteChB, and MuteSub bits, can mute channel A, channel B, or the sub channel (respectively).

Master control allows the volume of all channels to be changed simultaneously by offsetting each channel's individual volume setting by an additional +24 dB to -103 dB in 0.5 dB steps. By default, master volume is set to +3dB; if the CS4525 is being used to control the application's master volume, then it is recommended to change this value to a comfortable listening level before enabling the PWM powered outputs. Master volume control is accomplished via the Master Vol register.

The PWM outputs can be configured to output silence as a modulated signal or an non-modulated 50% duty cycle signal during a mute condition. This selection is achieved via the Mute50/50 bit in the Volume Cfg register.

The AutoMute bit in the same register dictates whether the device will automatically mute after the reception of 8192 consecutive samples of static 0 or -1. When the AutoMute function is enabled, a single sample of non-static data will cause the automatic mute to be released.

The CS4525 implements soft-ramp and zero-crossing detection capabilities to provide noise-free level transitions. When the zero-crossing function is enabled, all volume and muting changes are made on an output signal zero-crossing. The zero-crossing detection function is implemented independently for each channel. When the soft-ramp function is enabled, the volume is ramped from its initial to its final level at a rate of ½ dB every 4 samples for 32, 44.1, and 48 kHz sample rates, and ½ dB every 8 samples for a 96 kHz sampling rate.

All volume and muting changes are implemented as dictated by the soft-ramp and zero-cross settings configured by the SZCMode[1:0] bits in the Volume Cfg register.

Referenced Control	Register Location
ChXVol	"Channel A and B Volume Control (Address 58h & 59h)" on page 83
SubVol	"Sub Channel Volume Control (Address 5Ah)" on page 83
MuteChX	"Independent Channel A & B Mute (MuteChX)" on page 84
MuteSub	"Sub Channel Mute (MuteSub)" on page 85
Master Vol	"Master Volume Control (Address 57h)" on page 82
Mute50/50	"Enable 50% Duty Cycle for Mute Condition (Mute50/50)" on page 80
AutoMute	"Auto-Mute (AutoMute)" on page 80
SZCMode	"Soft Ramp and Zero Cross Control (SZCMode[1:0])" on page 80

6.1.4.10 Peak Signal Limiter

When enabled, the limiter monitors the digital output following the volume control block, detects when peak levels exceed a selectable maximum threshold level and lowers the volume at a programmable attack rate until the signal peaks fall below the maximum threshold. When the signal level falls below a selectable minimum threshold, the volume returns to its original level (as determined by the individual and master volume control registers) at a programmable release rate. Attack and release rates are affected by the soft ramp/zero cross settings and sample rate, F_s .

Recommended settings: Best limiting performance may be realized with the fastest attack and slowest release setting with soft ramp enabled in the control registers. Use the “minimum” bits to set a threshold slightly below the maximum threshold to cushion the sound as the limiter attacks and releases.

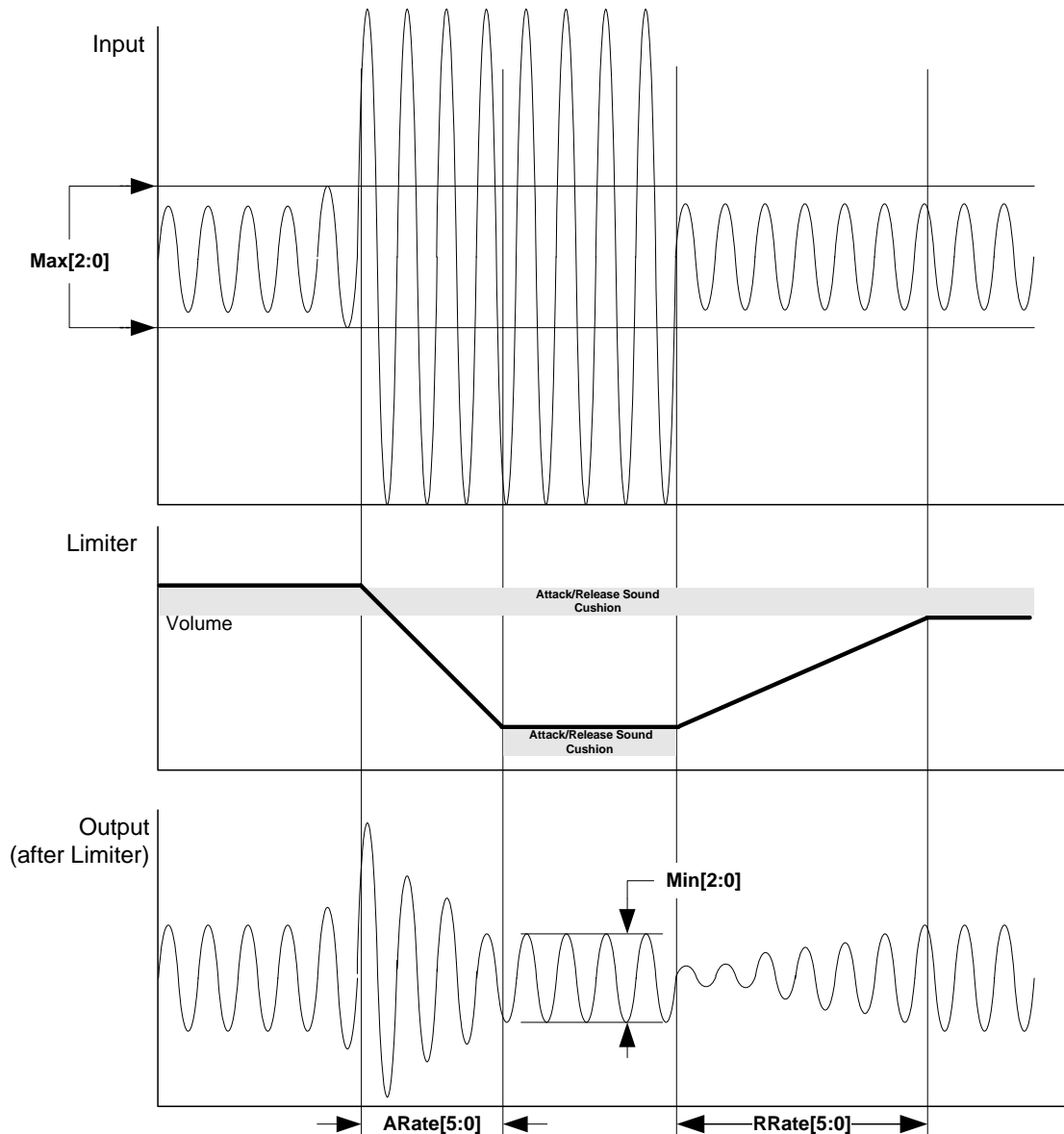

Figure 17. Peak Signal Detection & Limiting

By default, the limiter affects all channels when the maximum threshold is exceeded on any single channel. This default functionality is designed to keep all output channels at the same volume level while the limiter is in use. This behavior can be disabled by clearing the LimitAll bit in the Limiter Cfg 1 register.

When the LimitAll feature is activated, attenuation will be applied to all channels when a single channel exceeds the maximum threshold and released when the level of all channels is below the minimum threshold. When the LimitAll feature is de-activated, limiter attenuation will be applied and released on a per-channel basis and will only affect the channel on which the limiter event occurred.

The limiter can be enabled by setting the EnLimiter bit in the Limiter Cfg 1 register

The limiter can also be used in conjunction with the thermal limiter function to provide thermal error protection to the CS4525. The thermal limiter function is described in [Thermal Limiter](#) on [page 39](#).

Referenced Control	Register Location
EnLimiter	"Peak Detect and Limiter Enable (EnLimiter)" on page 86
LimitAll	"Peak Signal Limit All Channels (LimitAll)" on page 86
Max[2:0]	"Maximum Threshold (Max[2:0])" on page 85
Min[2:0]	"Minimum Threshold (Min[2:0])" on page 85
ARate[5:0]	"Limiter Attack Rate (ARate[5:0])" on page 87
RRate[5:0]	"Limiter Release Rate (RRate[5:0])" on page 87

6.1.4.11 Thermal Limiter

The CS4525 implements a thermal limiter function to provide a quick corrective response to potentially damaging thermal overload conditions. The thermal limiter feature operates by sensing the presence of a thermal warning condition and, in response, utilizes the peak signal limiter to dynamically limit the signal amplitude prior to the PWM modulators. This effectively limits the output power capability of the device, thereby allowing the temperature to reduce to acceptable levels without fully interrupting operation.

The thermal limiter is enabled by the EnThLim bit in the Limiter Configuration 3 register. When enabled, the thermal limiter will trigger once when either of the following conditions is met:

1. The junction temperature crosses the thermal warning threshold for the first time after the thermal limiter function is enabled.
2. The junction temperature is greater than the thermal warning threshold at the time the thermal limiter function is enabled.

Once triggered, the thermal limiter will remain in a triggered state until the RST pin is driven low.

When in the triggered state, the thermal limiter will engage whenever the EnThLim bit is set. While engaged, the thermal limiter utilizes the peak signal limiter function to dynamically limit the signal amplitude prior to the PWM modulators via the peak signal limiter; the characteristics of this limiting function are described in [Section 6.1.4.10](#) on [page 37](#). If the thermal limiter is engaged and the peak signal limiter is disabled via the EnLimiter bit, the peak signal limiter will be automatically enabled and its minimum and maximum thresholds will be set to -3 dB. If the thermal limiter is engaged and the peak signal limiter is enabled, an additional -3dB will be automatically applied to the minimum and maximum thresholds established in the Limiter Cfg 1 register. The automatic enabling of the peak signal limiter and the automatic application of additional attenuation to its thresholds is done internal to the CS4245; the values of the EnLimiter, Min[2:0], and Max[2:0] bits in the Limiter Cfg 1 register are not affected by the engagement of the thermal limiter function.

It should be noted that the thermal limiter can only be triggered once following the release of the $\overline{\text{RST}}$ signal. Once it has triggered, the thermal limiter's attenuation will always be implemented while the thermal limiter is enabled. If the thermal limiter is disabled after it has triggered, the internal enabling of the peak signal limiter and the additional -3 dB attenuation applied to its minimum and maximum thresholds will be released. In this state, the peak signal limiter's operation will follow the EnLimiter, Min[2:0], and Max[2:0] bits with no internal modification. If EnThLim is set again before the CS4525 has been reset (by toggling the RST pin low and then high), thermal limiting will engage immediately.

Referenced Control	Register Location
EnThLim	"Enable Thermal Limiter (EnThLim)" on page 87
EnLimiter	"Peak Detect and Limiter Enable (EnLimiter)" on page 86
Max[2:0]	"Maximum Threshold (Max[2:0])" on page 85
Min[2:0]	"Minimum Threshold (Min[2:0])" on page 85

6.1.4.12 Thermal Foldback

The CS4525 implements comprehensive thermal foldback features to guard against damaging thermal overload conditions. Thermal foldback is similar to the thermal limiting described on [page 39](#) in that both features attenuate the output signal in response to thermal warnings conditions; however, thermal foldback will attenuate as a function of how long thermal warning has been active whereas thermal limiter always limits by a constant amount. Also, the thermal foldback feature will deactivate once the thermal warning condition ceases while the thermal limiter will remain active once triggered until the $\overline{\text{RST}}$ pin is driven low.

The thermal foldback algorithm begins limiting the volume of the digital audio input to the amplifier stage as the junction temperatures rise above the maximum safe operating range specified by the thermal warning trigger point listed in the [PWM Power Output Characteristics](#) table on [page 20](#). This effectively limits the output power capability of the device, thereby allowing the temperature to reduce to acceptable levels without fully interrupting operation. As the device cools, the applied attenuation is gradually released until a new thermal equilibrium is reached or all applied attenuation has been released thereby allowing the device to again achieve its full output power capability.

Attenuation applied due to thermal foldback reduces the audio output level in a linear manner. [Figure 18](#) below demonstrates the foldback process.

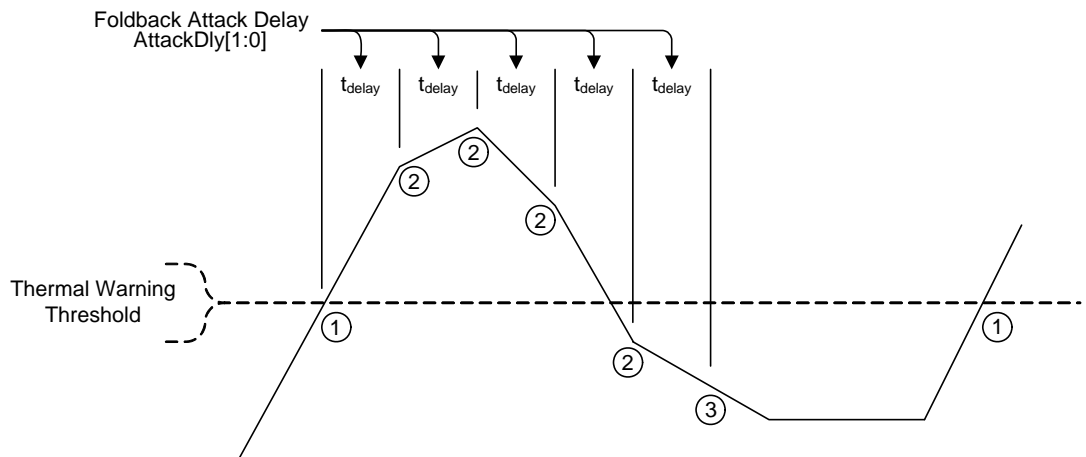

- ① When the junction temperature crosses the thermal warning threshold, the foldback attack delay timer is started.
- ② When the foldback attack delay timer reaches t_{delay} seconds, the junction temperature is checked. If the junction temperature is above the thermal warning threshold, the output volume level is lowered by 0.5 dB and the foldback attack timer is restarted.

The junction temperature is checked after each foldback attack timer timeout, and if necessary, the output volume level is lowered accordingly.

If the junction temperature is found to be below the thermal warning threshold, the foldback attack timer is restarted once again, but the output volume level is not altered. The foldback algorithm then proceeds to step 3.

- ③ The junction temperature is checked once again after the next foldback attack timer timeout. If it has remained below the thermal warning threshold since the last check, the device will begin to release any attenuation applied as a result of the foldback event. Setting the LockAdj bit will prevent the device from removing the applied attenuation when the thermal overload condition has cleared.

If the junction temperature crosses the thermal warning threshold again, the foldback algorithm will once again enter step 1.

Figure 18. Foldback Process

The AttackDly[1:0] bits in the Foldback Cfg register allow the foldback attack delay timeout period to be adjusted from approximately 0.5 seconds to approximately 2.0 seconds. The maximum attenuation applied by the thermal foldback algorithm can be restricted to -30 dB by setting the EnFloor bit in the same register.

The foldback adjustment lock feature causes the attenuation applied by the foldback algorithm to be maintained after the foldback condition has subsided. The applied attenuation will continue to be applied until the master volume or all active channel volume controls are lowered below the foldback attenuation level, or until a subsequent foldback condition occurs causing the applied attenuation to be lowered further. If the foldback algorithm applies attenuation while this feature is enabled, when the feature is subsequently disabled, the applied attenuation will be gradually released as long as the temperature remains within the safe operating range. This foldback lock adjustment feature is enabled by the LockAdj bit in the Foldback Cfg register.

Thermal warnings will only affect the foldback algorithm and cause attenuation to be applied when enabled by the EnTherm bit in the Foldback Cfg register.

The CS4525 can be configured to accept an external thermal warning indicator input. When in this configuration, an active input signal indicates that a thermal warning threshold has been exceeded. If thermal foldback is enabled, the foldback algorithm will respond as described above making no distinction between an internal or external thermal warning condition. See [“External Warning Input Port” on page 44](#) for more information.

Referenced Control	Register Location
EnTherm	“Enable Thermal Foldback (EnTherm)” on page 74
AttackDly[1:0]	“Foldback Attack Delay (AttackDly[1:0])” on page 75
EnFloor	“Enable Foldback Floor (EnFloor)” on page 75
LockAdj	“Lock Foldback Adjust (LockAdj)” on page 74

6.1.4.13 2-Way Crossover & Sensitivity Control

The CS4525 implements a dedicated stereo 24 dB/octave Linkwitz-Riley crossover filter with adjustable cross-over frequency and sensitivity control to facilitate 2-way speaker configurations. The filter’s high-pass output can be used to drive the tweeter, and its low-pass output is used can be drive the mid-range/woofer. The sensitivity control is included to adjust the level of the high-pass and low-pass outputs to compensate for differences in the tweeter and mid-range/woofer sensitivity.

The two-way crossover is implemented with one of two preset internal filter sets. One set is optimized for a 32 kHz sample rate, and the other is optimized for 44.1 kHz, 48 kHz, and 96 kHz sample rates. The CS4525 automatically detects the input sample rate and chooses the appropriate filter set to apply. The available cross-over frequencies are shown in [Table 5](#) below and are configured with the 2WayFreq[2:0] bits in the Volume Cfg register.

Note that the corner frequency of each filter set scales linearly with the input sample rate.

When the internal ADC is used as the serial audio data source, the input sample rate is nominally 48 kHz and the corresponding shelving frequency corners are available.

	Input Sample Rate		
	32 kHz	44.1 kHz	48 kHz, 96 kHz
X-Over Freq 0	2.0 kHz	1.92 kHz	2.09 kHz
X-Over Freq 1	2.2 kHz	2.11 kHz	2.30 kHz
X-Over Freq 2	2.4 kHz	2.30 kHz	2.50 kHz
X-Over Freq 3	2.6 kHz	2.49 kHz	2.71 kHz
X-Over Freq 4	2.8 kHz	2.68 kHz	2.92 kHz

Table 5. 2-Way Cross-Over Frequencies

	Input Sample Rate		
	32 kHz	44.1 kHz	48 kHz, 96 kHz
X-Over Freq 5	3.0 kHz	2.88 kHz	3.13 kHz
X-Over Freq 6	3.2 kHz	3.07 kHz	3.34 kHz
X-Over Freq 7	3.4 kHz	3.26 kHz	3.55 kHz

Table 5. 2-Way Cross-Over Frequencies

The sensitivity level of the high- and low-pass outputs of the crossovers can be independently adjusted from 0 dB to -7.5 dB in 0.5 dB increments. The maximum attenuation level of -7.5 dB will compensate for an approximate 4 dB difference in sound pressure level (SPL) between the tweeter and the mid-range/woofer drivers. The sensitivity is adjusted using the HighPass[3:0] and LowPass[3:0] bits in the Sensitivity register. Note that these bits affect the sensitivity of both channel A and channel B high- and low-pass outputs.

The 2-way crossover can be enabled by setting the En2Way bit in the Volume Cfg register.

Referenced Control	Register Location
En2Way.....	“Enable 2-Way Crossover (En2Way)” on page 81
2WayFreq[2:0].....	“2-Way Cross-Over Frequency (2WayFreq[2:0])” on page 81
HighPass[3:0].....	“Channel A and Channel B High-Pass Sensitivity Adjust (HighPass[3:0])” on page 82
LowPass[3:0].....	“Channel A and Channel B Low-Pass Sensitivity Adjust (LowPass[3:0])” on page 81

6.1.5 Auxiliary Serial Output

The CS4525 includes a stereo auxiliary serial output which allows an external device to leverage on its internal signal processing and routing capabilities. The auxiliary serial output can receive its data from any of the sources shown in the [Digital Signal Flow](#) diagram on [page 29](#).

The supported output data routing configurations are shown in [Table 6](#) below. By default, the serial port is configured to output channels A and B on the auxiliary output data left and right channels respectively.

LChDSEL[1:0]	Aux Left Channel Data	RChDSEL[1:0]	Aux Right Channel Data
00	Channel A	00	Channel A
01	Channel B	01	Channel B
10	Sub Channel	10	Sub Channel
11	Channel B X-Over LPF	11	Channel B X-Over HPF

Table 6. Auxiliary Serial Port Data Output

The data output on each channel of AUX_SDOUT is set by the LChDSEL[1:0] and RChDSEL[1:0] bits in the Aux Port Configuration register. The frequencies of AUX_LRCK and AUX_SCLK will vary based upon the whether the serial input or analog input is being used and the frequency of the system clock for the CS4525; the nominal values for these clocks are listed in [Table 7](#). The characteristics of AUX_SCLK, AUX_LRCK, and AUX_SDOUT are described in the [AUX Serial Audio I/O Port Switching Specifications](#) table on [page 22](#).

Signal	ADC/SP = 0 (Digital Input Mode)		ADC/SP = 1 (Analog Input Mode)		
	Applied System Clock from either SYS_CLK or External Crystal	18.432, 24.576, or 27.000MHz		18.432MHz	24.576MHz
Frequency of LRCK Input	32kHz, 44.1kHz, or 48kHz	96kHz	Not Applicable		
Nominal Frequency of AUX_SCLK Output	Frequency of SCLK Input	Frequency of SCLK Input / 2	2.304MHz	3.072MHz	3.375MHz
Nominal Frequency of AUX_LRCK Output	Frequency of LRCK Input	Frequency of LRCK Input / 2	48kHz	48kHz	52.734kHz

Table 7. Nominal Switching Frequencies of the Auxiliary Serial Output

The auxiliary port can be enabled using the EnAuxPort bit. When enabled, the port operates as a master and clocks out data in the format dictated by the AuxI²S/LJ bit. When disabled, the AUX_LRCK, AUX_SCLK, and AUX_SDOUT pins continuously drive a logic '0'. It should be noted that when the CS4525 is configured for analog input, the AUX_LRCK, AUX_SCLK, and AUX_SDOUT pins will continuously drive a logic '0' if either the PDnADC bit or PDnAll bit is set.

Referenced Control	Register Location
EnAuxPort	"Enable Aux Serial Port (EnAuxPort)" on page 72
LChDSEL[1:0]	"Aux Serial Port Left Channel Data Select (LChDSEL[1:0])" on page 73
RChDSEL[1:0]	"Aux Serial Port Right Channel Data Select (RChDSEL[1:0])" on page 72
AuxI ² S/LJ	"Aux/Delay Serial Port Digital Interface Format (AuxI ² S/LJ)" on page 72
PDnADC	"Power Down ADC (PDnADC)" on page 88
PDnAll	"Power Down (PDnAll)" on page 89

6.1.6 Serial Audio Delay & Warning Input Port

The CS4525 includes a configurable delay and warning port to allow easy system integration of external lip-sync delay devices or warning inputs from external amplifiers. The port can be configured as a serial audio delay interface, an external warning input port, or disabled by the `DlyPortCfg[1:0]` bits in the Aux Config register. When disabled, the `DLY_SDOUT` and `DLY_SDIN/EX_TWR` pins become high-impedance.

Referenced Control	Register Location
<code>DlyPortCfg</code>	“Delay & Warning Port Configuration (DlyPortCfg[1:0])” on page 72

6.1.6.1 Serial Audio Delay Interface

Video processing and reproduction circuitry in digital video display devices can often introduce noticeably more delay than is introduced by the device’s audio processing and reproduction circuitry. This can result in a phenomenon known as lip-synch delay - a delay present between the video and audio content being reproduced.

To help overcome this problem, the CS4525 delay and warning port can be configured as serial audio delay interface. This interface consists of a serial audio input/output port to facilitate the use of an external serial audio delay device. The port routes the serial data from the selected input source (the ADC or the serial input port) out to an external serial audio delay device, and then back in to the CS4525 internal digital sound processing blocks. The delay serial audio interface signals include `DLY_SDOUT` and `DLY_SDIN/EX_TWR` and are clocked from `AUX_LRCK` and `AUX_SCLK`. The serial data is output on the `DLY_SDOUT` pin and input on the `DLY_SDIN/EX_TWR` in the format specified by the `AuxI2S/LJ` bits in the Aux Config register. Because the delay interface uses the auxiliary port clock signals, the auxiliary serial port must be enabled using the `EnAuxPort` bit in the Aux Port Configuration register to allow the delay interface to operate properly.

Referenced Control	Register Location
<code>AuxI²S/LJ</code>	“Aux/Delay Serial Port Digital Interface Format (AuxI²S/LJ)” on page 72
<code>EnAuxPort</code>	“Enable Aux Serial Port (EnAuxPort)” on page 72

6.1.6.2 External Warning Input Port

When implementing external PWM power stage devices with thermal warning indicator outputs, it can be useful to provide these warning signals as an input to the internal thermal foldback algorithm. This allows the CS4525 to automatically respond to the external devices’ thermal warning conditions without completely disrupting the system’s operation.

When configured as an external warning input port, the `DLY_SDIN/EX_TWR` is an active-low thermal warning input to the foldback algorithm and the `DLY_SDOUT` pin becomes high-impedance.

In order for the foldback algorithm to act on the external thermal warning input signal, the thermal foldback algorithm must be enabled by the `EnTherm` bit in the Foldback Cfg register. See [“Thermal Foldback” on page 40](#) for more information.

Referenced Control	Register Location
<code>EnTherm</code>	“Enable Thermal Foldback (EnTherm)” on page 74

6.1.7 Powered PWM Outputs

The CS4525's 3 internal modulators can be used to generate multiple powered PWM output configurations to enable a wide variety of system implementations. The CS4525 also implements PWM Popguard to minimize output transients in half-bridge configurations.

6.1.7.1 Output Channel Configurations

Three PWM power output configurations are supported as shown in [Table 8](#) below. The configurations support stereo full-bridge, stereo half-bridge with full-bridge sub, and mono parallel full-bridge output.

OutputCfg[1:0]	Power Configuration	Output Signal	Output Pin(s)
00	2 Ch. Full-Bridge	Channel 1 + Channel 1 - Channel 2 + Channel 2 -	OUT1 OUT2 OUT3 OUT4
01	2 Ch. Half-Bridge + 1 Ch. Full-Bridge	Channel 1 + Channel 2 + Sub Channel + Sub Channel -	OUT1 OUT2 OUT3 OUT4
10	1 Ch. Parallel Full-Bridge	Channel 1 + Channel 1 -	OUT1, OUT2 OUT3, OUT4

Table 8. PWM Power Output Configurations

The configurations are selected by the OutputCfg[1:0] bits in the Output Cfg register and must only be changed when the device is in power-down mode (the PDnAll bit is set). Any attempt to write the OutputCfg[1:0] bits while the device is powered-up will be ignored.

It should be noted that signals on channels 1, 2 and the sub channel are dependent upon the digital sound processing blocks being used. For instance, if the 2-way crossover is enabled, channel 1 and 2 contain the 2-way crossover channel A high- and low-pass outputs respectively. For more information, see the [Digital Sound Processing](#) section and [Figure 14 on page 29](#).

Referenced Control	Register Location
OutputCfg[1:0].....	"Output Configuration (OutputCfg[1:0])" on page 73
PDnAll	"Power Down (PDnAll)" on page 89

6.1.7.2 PWM Popguard Transient Control

The CS4525 uses Popguard technology to minimize the effects of power-up and power-down output transients commonly produced by half-bridge, single supply amplifiers implemented with external DC-blocking capacitors connected in series with the audio outputs.

PWM Popguard operates by linearly ramping the PWM power outputs up to and down from their bias point of VP/2 when a channel is powered up and down respectively using the PDnOutX or PDnAll bits. This

gradual voltage ramp minimizes output transients while the DC blocking capacitor is charged and discharged. The Popguard has no effect on the PWM_SIG outputs nor the auxiliary serial output.

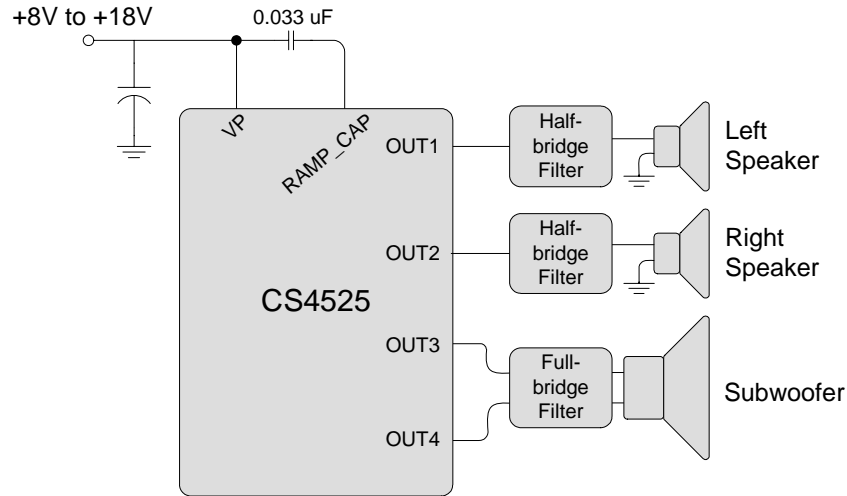

Figure 19. Popguard Connection Diagram

PWM Popguard is disabled by default; to enable it, the RmpSpd[1:0] register must be set to any value other than 11. PWM Popguard should only be used for has when the power outputs are configured for stereo half-bridge with full-bridge sub per [Section 6.1.7.1](#). The RAMP_CAP pin must be connected to the VP supply through a 0.033 μ F capacitor whenever PWM Popguard is enabled, as shown in [Figure 19](#).

VP Voltage	Typical Ramp Up Times			
	RmpSpd[1:0] = 00	RmpSpd[1:0] = 01	RmpSpd[1:0] = 10	RmpSpd[1:0] = 11
12 V	2.16 seconds	2.20 seconds	2.20 seconds	Instant (No Ramp)
15 V	1.74 seconds	1.76 seconds	1.78 seconds	Instant (No Ramp)
18 V	1.40 seconds	1.42 seconds	1.44 seconds	Instant (No Ramp)

Table 9. Typical Ramp Times for Various VP Voltages

PWM Popguard’s output ramp time will vary depending on the voltage applied to VP and the value of the RmpSpd[1:0] bits; typical ramp times are listed in [Table 9](#). All output channels are affected by the RmpSpeed[1:0] bits, and PWM Popguard is disabled by default.

Referenced Control	Register Location
RmpSpeed[1:0]	“Ramp Speed (RmpSpd[1:0])” on page 75
PDnAll	“Power Down (PDnAll)” on page 89
PDnOutX	“Power Down PWM Power Output X (PDnOutX)” on page 88

6.1.8 Logic-Level PWM Outputs

The CS4525 has two configurable logic-level PWM outputs, PWM_SIG1 and PWM_SIG2. These outputs can be used as either digital input to an external PWM amplifier such as the CS4412, or as an analog input to a headphone amplifier or a line-out amplifier.

To eliminate power-up pops when used to supply an external PWM amplifier, the CS4525 implements the same click-free start-up function on the PWM_SIG outputs as it does for its own powered PWM outputs. This function can only be utilized if the PWM amplifier has an initial transition delay feature, such as the CS4412A. To eliminate power-up and power-down pops when used to supply an analog output circuit, the PWM_SIG outputs support a high-impedance state that is controlled by the HiZPSig bit in the

EQ Config register. This bit is active-low and cleared by default. To use the PWM_SIG outputs, the HiZPSig bit must be set to enable the PWM_SIG output drivers.

6.1.8.1 Recommended PWM_SIG Power-Up Sequence for an External PWM Amplifier

1. Engage the reset/power-down feature of the external PWM amplifier.
2. Set the PDnAll bit in the Power Ctrl register to stop the PWM modulators if it is not already set.
3. Configure the PWM_SIG outputs as desired via the PWMDSel[1:0] bits in the Output Cfg register.
4. Set the HiZPSig bit in the EQ Config register to activate the PWM_SIG output drivers.
5. Disengage the reset/power-down feature of the external PWM amplifier if it has an initial transition delay feature, such as the CS4412A.

WARNING: Releasing the external amplifier from reset/power-down before PWM modulators have started will cause a DC output on the speakers unless the external amplifier has an initial transition delay feature.

6. Clear the PDnAll bit in the Power Ctrl register to start the PWM modulators.
7. Disengage the reset/power-down feature of the external PWM amplifier if it has not been yet disengaged.

6.1.8.2 Recommended PWM_SIG Power-Down Sequence for an External PWM Amplifier

1. Mute the PWM_SIG outputs to a 50% duty-cycle by either setting Master Volume to 1111 1111h (Master Mute) or through use of the HP_DETECT/MUTE input pin as described in the [Headphone Detection & Hardware Mute Input](#) section on [page 51](#).
2. Engage the reset/power-down feature of the external PWM amplifier.
3. Set the PDnAll bit in the Power Ctrl register to disable the PWM modulators and set the PWM_SIG outputs to a drive a logic '0'.
4. Power down the remainder of the system (if applicable).

6.1.8.3 Recommended PWM_SIG Power-Up Sequence for Headphone & Line-Out

1. Set the PDnAll bit in the Power Ctrl register to stop the PWM modulators if it is not already set.
2. Configure the PWM_SIG outputs as desired via the PWMDSel[1:0] bits in the Output Cfg register.
3. Clear the PDnAll bit in the Power Ctrl register to start the PWM modulators.
4. Wait 500 ms to allow the internal sample rate converters to achieve lock.
5. Set the HiZPSig bit in the EQ Config register to activate the PWM_SIG outputs.

6.1.8.4 Recommended PWM_SIG Power-Down Sequence for Headphone & Line-Out

1. Mute the PWM_SIG outputs to a 50% duty-cycle by either setting Master Volume to 1111 1111h (Master Mute) or through use of the HP_DETECT/MUTE input pin as described in the [Headphone Detection & Hardware Mute Input](#) section on [page 51](#).
2. Clear the HiZPSig bit in the EQ Config register to put the PWM_SIG output drivers in a high-impedance state.
3. Power down the remainder of the system (if applicable).

Referenced Control	Register Location
PDnAll	"Power Down (PDnAll)" on page 89
HiZPSig	"Hi-Z PWM_SIG Outputs (HiZPSig)" on page 79
PWMDSel[1:0]	"PWM Signals Output Data Select (PWMDSel[1:0])" on page 73
Master Volume	"Master Volume Control (MVol[7:0])" on page 82

6.1.8.5 PWM_SIG Logic-Level Output Configurations

Four channel mapping output configurations are supported for the PWM_SIG output pins as shown in [Table 10](#) below. The configurations support stereo, channel 1 with sub, and channel 2 with sub applications. When disabled, the PWM_SIG pins will continuously drive a logic '0' if the HiZPSig bit is set and will be held in a high-impedance state if the HiZPSig bit is clear. The configurations are selected by the PWMDSel[1:0] bits in the Output Cfg register. The PWM_SIG2 can be configured to output the sub channel even if the Bass Manager is not enabled; however, its signal will be muted unless the Bass Manager is enabled by the BassMgr[2:0] bits. It should be noted that the HiZPSig bit must be set to enable the PWM_SIG output drivers.

PWMDSel[1:0]	PWM_SIG1	PWM_SIG2
00	Disabled.	Disabled.
01	Channel 1	Channel 2
10	Channel 1	Sub Channel
11	Channel 2	Sub Channel

Table 10. PWM Logic-Level Output Configurations

To allow stereo headphone operation when the PWM logic-level outputs are mapped in a non-stereo output configuration, if the HP_DETECT/MUTE pin is configured for headphone detection (the HP/Mute bit is set), the PWM logic-level output mapping can be affected by the active state of the headphone detection input signal. See the [Headphone Detection & Hardware Mute Input](#) section on [page 51](#) for more information.

It should be noted that signal on channels 1, 2, and the sub channel are dependent upon the digital sound processing blocks being used. For instance, if the 2-way crossover is enabled, channel 1 and 2 contain the 2-way crossover channel A high- and low-pass outputs respectively. For more information, see the [Digital Sound Processing](#) section and [Figure 14](#) on [page 29](#).

Referenced Control	Register Location
PWMDSel[1:0].....	"PWM Signals Output Data Select (PWMDSel[1:0])" on page 73
HiZPSig.....	"Hi-Z PWM_SIG Outputs (HiZPSig)" on page 79
HP/Mute.....	"HP_Detect/Mute Pin Mode (HP/Mute)" on page 70
BassMgr[2:0].....	"Bass Cross-Over Frequency (BassMgr[2:0])" on page 79

6.1.9 PWM Modulator Configuration

The CS4525 PWM modulators support flexible configuration options designed to simplify system integration. Delays may be inserted between the switching edges on adjacent channels to manage noise, and the PWM switching frequency can be easily modified to eliminate interference with AM tuners.

6.1.9.1 PWM Channel Delay

The CS4525 includes a PWM output signal delay mechanism. This mechanism allows the PWM switching edges to be offset between channels as a method of managing switching noise and reducing radiated emissions.

The OutputDly[3:0] bits in the Output Cfg register are used to adjust the channel delay amount from 0 to 15 SYS_CLK or crystal input clock cycles, whichever is used as the input clock source. The absolute delay time is calculated by multiplying the setting of the OutputDly[3:0] bits by the period of the input clock source. By default, no delay is inserted.

When the power outputs are configured for 2-channel full-bridge operation, the OUT3/OUT4 signal pair is delayed from the OUT1/OUT2 signal pair by the delay amount as shown in [Figure 20](#).

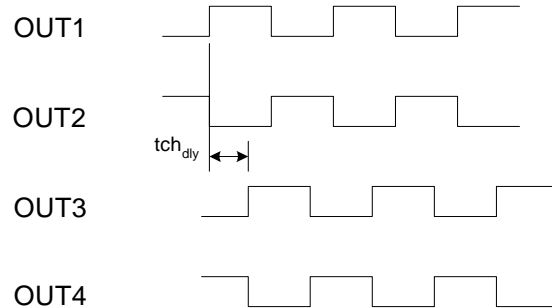

Figure 20. 2-Channel Full-Bridge PWM Output Delay

When the power outputs are configured for 3-channel (2-channel half-bridge and 1-channel full-bridge) operation, OUT2 is delayed from OUT1 by the delay amount, and the OUT3/OUT4 pair is delayed from OUT2 by the delay amount as shown in [Figure 21](#).

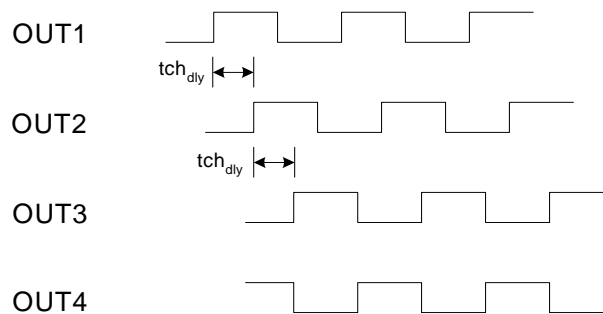

Figure 21. 3-Channel PWM Output Delay

The OutputDly[3:0] bits can only be changed when all modulators and associated logic are in the power-down state by setting the PDnAll bit. Attempts to write these bits while the PDnAll bit is cleared will be ignored.

Referenced Control	Register Location
OutputDly[3:0]	"Channel Delay Settings (OutputDly[3:0])" on page 73

6.1.9.2 PWM AM Frequency Shift

When using a PWM amplifier in a system containing an AM tuner, it is possible that the PWM switch rate conflicts with the desired tuning frequency of the AM tuner. To overcome this effect, the CS4525 includes a PWM switch rate shift feature.

The feature adjusts the PWM switching frequency and quantization levels to remove interference when the desired tuning frequency of an AM tuner is positioned near a harmonic of the PWM switching rate. This feature is enabled by setting the FreqShift bit in the Clock Config register. When this feature is enabled, the output switch rate is lowered and the quantization levels are increased as shown in [Table 11](#) below.

Supplied XTAL or SYS_CLK Frequency	PWM Switch Rate	Quantization Levels
18.432 MHz	329.143 kHz	56
24.576 MHz	341.300 kHz	72
27.000 MHz	375 kHz	72

Table 11. PWM Output Switching Rates and Quantization Levels

The nominal PWM switching frequencies and quantization levels are discussed in [“PWM Modulators and Sample Rate Converters”](#) on page 58.

Referenced Control	Register Location
FreqShift.....	“AM Frequency Shifting (FreqShift)” on page 70

6.1.10 Headphone Detection & Hardware Mute Input

The CS4525 includes a configurable HP_DETECT/MUTE input pin which can be used as a hardware mute input or a headphone detection input. The function of this pin is set by the HP/Mute bit in the Clock Config register.

When configured as a mute input pin, all PWM modulators and the AUX_SDOOUT signal will be placed in a mute state when the pin is active.

When configured as a headphone detect input pin and the HP_DETECT/MUTE input is active, the PWM_SIG1 and PWM_SIG2 output pins can output audio from channel 1 and channel 2 respectively regardless of the setting of the PWMDSel[1:0] bits. The OUT1 - OUT4 PWM driver outputs will mute by outputting a non-modulated 50% duty cycle signal. While the headphone detect input signal is active, the channel mixing, 2-way crossover, and bass management features will all be disabled regardless of the settings of the LChMix[1:0], En2Way, and BassMgr[2:0] bits, respectively. It should be noted that the right channel's channel mixing is not affected by the headphone detection input signal and will always output as dictated by the RChMix[1:0] bits. See [“Channel Mixer”](#) on page 30, [“2-Way Crossover & Sensitivity Control”](#) on page 41, and [“Bass Management”](#) on page 35 for more information.

When configured as a headphone detect input pin and the HP_DETECT/MUTE input is inactive, the OUT1 - OUT4 driver outputs will output audio according to the channel mixer and bass manager bits' settings, and the PWM_SIG output pins will mute by outputting a non-modulated 50% duty cycle.

HiZPSig Setting	HP/Mute Setting	HP_DETECT /MUTE Input	BassMgr [2:0] Setting	PWMDSel [1:0] Setting	PWM_SIG1 Output	PWM_SIG2 Output
0	X	X	X	X	High Impedance	High Impedance
1	X	X	X	00 (Disabled)	Driven Low	Driven Low
	0 (Mute Mode)	Not Active	000 (Disabled)	01	Channel 1	Channel 2
				10	Channel 1	Mute
				11	Channel 2	Mute
			001 through 111	01	Channel 1	Channel 2
				10	Channel 1	Sub Channel
				11	Channel 2	Sub Channel
	Active	X	01, 10, or 11	Mute	Mute	
	1 (Head-phone Mode)	Not Active	X	01, 10, or 11	Mute	Mute
		Active	000 (Disabled)	01	Channel 1*	Channel 2**
10				Channel 1*	Mute	
11				Channel 2**	Mute	
001 through 111	01, 10, or 11	Channel 1*	Channel 2**			

*Signals denoted with one asterisk do not have Bass Manager, 2-Way Crossover, or Channel Mix applied.

**Signals denoted with two asterisks do not have Bass Manager or 2-Way Crossover applied.

Table 12. Output of PWM_SIG Outputs

Table 12 describes the exact output of the PWM_SIG output pins based on the input to the HP_DETECT/MUTE pin and the settings of the HiZPSig, HP/Mute, BassMgr[2:0], and PWMDSel[1:0] bits. In all configurations, the active logic input level is determined by the HP/MutePol bit.

Referenced Control	Register Location
HP/Mute	"HP_Detect/Mute Pin Mode (HP/Mute)" on page 70
HP/MutePol	"HP_Detect/Mute Pin Active Logic Level (HP/MutePol)" on page 70
PWMDSel[1:0]	"PWM Signals Output Data Select (PWMDSel[1:0])" on page 73
LChMix[1:0]	"Left Channel Mixer (LChMix[1:0])" on page 76
RChMix[1:0]	"Right Channel Mixer (RChMix[1:0])" on page 76
En2Way	"Enable 2-Way Crossover (En2Way)" on page 81
BassMgr[2:0]	"Bass Cross-Over Frequency (BassMgr[2:0])" on page 79
HiZPSig	"Hi-Z PWM_SIG Outputs (HiZPSig)" on page 79

6.1.11 Interrupt Reporting

The CS4525 has comprehensive interrupt reporting capabilities. Many conditions including SRC lock, ADC overflow, digital data path overflow, and amplifier errors can cause an interrupt.

The $\overline{\text{INT}}$ output pin is intended to drive an interrupt input pin on a host microcontroller. The $\overline{\text{INT}}$ pin is an open-drain active-low output and requires an external pull-up for proper operation.

If an interrupt source is un-masked, its occurrence will cause the interrupt output pin to become active. To enhance flexibility, each interrupt source may be masked such that its occurrence does not cause the interrupt output pin to become active. This masking function is accomplished by clearing an interrupt's respective mask bit located in the 4 LSB's of the Interrupt register.

When a specific interrupt condition occurs, it's respective bit located in the 4 MSB's of the Interrupt register will be set to indicate that a change has occurred for the associated interrupt type. When the interrupt register is read, the contents of the 4 MSB's will be cleared. The Int Status register may then be read to determine the current state of the interrupt source.

For specific information regarding interrupt types and reporting, see the Interrupt, Int Status and Amp Error register descriptions.

Referenced Control	Register Location
Interrupt Register	"Interrupt (Address 60h)" on page 89
Int Status Register.....	"Interrupt Status (Address 61h) - Read Only" on page 92
Amp Error Register	"Amplifier Error Status (Address 62h) - Read Only" on page 93

6.1.12 Automatic Power Stage Shut-Down

To prevent permanent damage, the CS4525 will automatically shut down its internal PWM power output stages when a thermal error, PWM power output over-current error, or VP under-voltage condition occurs. In the shut-down state, all digital functions of the device will operate as normal, however the PWM power output pins become high-impedance.

The levels of the over-current error, thermal error, and VP under-voltage trigger points are listed in the [PWM Power Output Characteristics](#) table on [page 20](#). Automatic shut-down will occur whenever any of these preset thresholds are crossed.

Once in the shut-down state, each powered PWM outputs will remain as high-impedance and will not resume normal operation until either the PDnAll bit or the PDnOutX bit for the channel in error is set and then cleared.

If the AutoRetry bit is set, the CS4525 will attempt to automatically resume power output operation after an over-current error is encountered and before entering the shut-down state. With the AutoRetry function enabled, the CS4525 will place the PWM power outputs in a high-impedance state upon the sensing of an over-current condition, wait approximately 85 ms, and then re-engage the power outputs in an attempt to resume normal operation. If another over-current condition is immediately detected, the PWM power outputs will again be placed in a high-impedance state before retrying to resume normal operation a second time. It will continue this sequence for a maximum of five attempts. After the fifth unsuccessful attempt, the outputs will remain in a high-impedance state until the PDnAll bit is set and then cleared.

Referenced Control	Register Location
AutoRetry	"Automatic Power Stage Retry (AutoRetry)" on page 88
PDnAll	"Power Down (PDnAll)" on page 89
PDnOutX	"Power Down PWM Power Output X (PDnOutX)" on page 88

6.2 Hardware Mode

A limited feature set is available when the CS4525 powers up in hardware mode. The available features are described in the following sections. All device configuration is achieved via hardware control input pins.

6.2.1 System Clocking

In hardware mode, the CS4525 must be clocked by a stable external clock source input on the SYS_CLK pin. This input clock is used to synchronize the input serial audio signals with the internal clock domain and to clock the internal digital processing, sample-rate converter, and PWM modulators. It is also used to determine the sample rate of the serial audio input signals in order to automatically configure the various internal filter coefficients.

To ensure proper operation, the CS4525 must be informed of the nominal frequency of the supplied SYS_CLK signal via the ClkFreq[1:0] hardware control pins. These pins must be set to the appropriate level before the $\overline{\text{RST}}$ signal is released to initiate a power-up sequence. The nominal clock frequencies indicated by the states of the ClkFreq[1:0] pins are shown in Table 13 below. See the [SYS_CLK Switching Specifications](#) table on page 23 for complete input frequency range specifications.

ClkFreq1	ClkFreq0	Nominal SYS_CLK Frequency
Low	Low	18.432 MHz
Low	High	24.576 MHz
High	Low	27.000 MHz
High	High	Reserved

Table 13. SYS_CLOCK Frequency Selection

WARNING: The SYS_CLK signal must never be removed or stopped while the $\overline{\text{RST}}$ pin is high and any of the power output stages are connected to a load. Doing so may result in permanent damage to the CS4525 and connected transducers.

Figure 22 below demonstrates a typical clocking configuration using the SYS_CLK input.

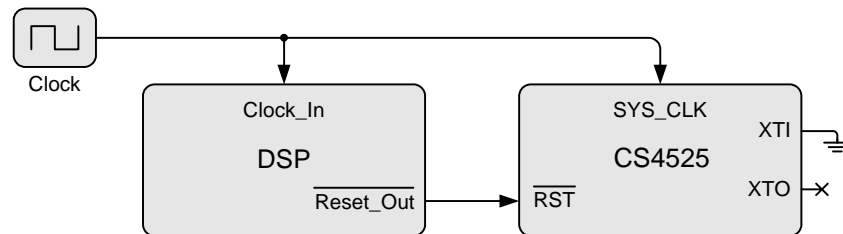

Figure 22. Typical SYS_CLK Input Clocking Configuration

6.2.2 Power-Up and Power-Down

The CS4525 will remain in a completely powered-down state until the $\overline{\text{RST}}$ pin is brought high.

6.2.2.1 Recommended Power-Up Sequence

1. Hold $\overline{\text{RST}}$ low until the power supplies and the input SYS_CLK signal are stable.
2. Bring $\overline{\text{RST}}$ high.
Hardware mode will be entered after approximately 10 ms.

6.2.2.2 Recommended Power-Down Sequence

1. Bring $\overline{\text{MUTE}}$ low to mute the device's outputs and minimize audible pops.
2. Bring $\overline{\text{RST}}$ low to halt the operation of the device.
The device's power consumption will be brought to an absolute minimum.
3. Remove power.

6.2.3 Input Source Selection

The CS4525 can accept analog or digital audio input signals. Digital audio input signals are supplied through the serial audio input port as outlined in “Serial Audio Interfaces” on page 62. Analog audio input signals are supplied through the internal ADC as outlined in “Analog Inputs” on page 61. The input source is selected by the ADC/SP pin as shown in Table 14 below and can be changed at any time without causing any audible pops or clicks.

ADC/SP	Selected Input Source
Low	Digital Audio Inputs (Serial Port)
High	Analog Audio Inputs (ADC)

Table 14. Input Source Selection

In hardware mode, the serial audio input port supports both I²S and left-justified formats. The serial audio interface format is selected by the I2S/LJ pin as shown in Table 15 below.

I2S/LJ	Selected Serial Audio Interface Format
Low	Left-Justified
High	I ² S

Table 15. Serial Audio Interface Format Selection

6.2.4 PWM Channel Delay

In hardware mode, the CS4525 offsets the PWM switching edges between channels as a method of managing switching noise and reducing radiated emissions.

The OUT3/OUT4 signal pair is delayed from the OUT1/OUT2 signal pair by 4 SYS_CLK cycles as shown in Figure 23 below. The absolute delay time is calculated by multiplying the period SYS_CLK by 4.

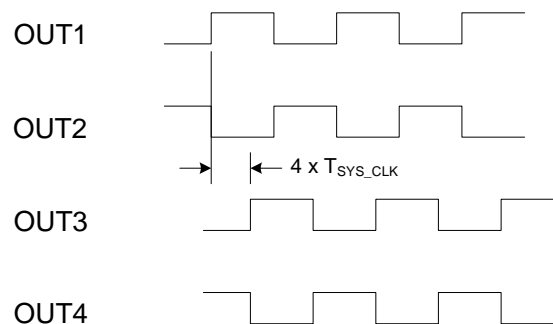

Figure 23. Hardware Mode PWM Output Delay

6.2.5 Digital Signal Flow

In hardware mode, the CS4525 operates as a 2-channel full-bridge PWM amplifier with analog or digital inputs. Both the PWM outputs and the auxiliary serial outputs are unavailable in hardware mode. To protect against over-temperature conditions, thermal foldback is included for the internal power stages.

The digital signal flow is shown in [Figure 24](#) below.

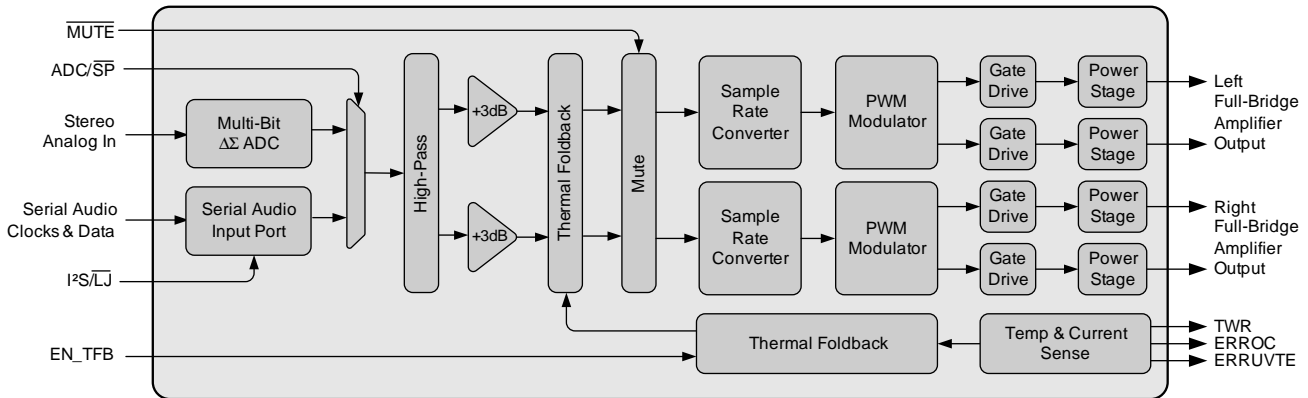

Figure 24. Hardware Mode Digital Signal Flow

6.2.5.1 High-Pass Filter

The CS4525 includes a high-pass filter at the beginning of the digital signal processing chain to remove any DC content from the input signal prior to the remaining internal digital signal processing blocks. The high-pass filter operates by continuously subtracting a measure of the DC offset from the input signal; it is always enabled.

6.2.5.2 Mute Control

The CS4525 includes a dedicated $\overline{\text{MUTE}}$ input pin. When low, the PWM outputs will output silence as modulated signal. When high, the selected input source will be presented at the amplifier outputs.

It should be noted that the auto-mute, soft-ramp, and zero-crossing detection features are active in hardware mode.

6.2.5.3 Warning and Error Reporting

The CS4525 is capable of reporting various error and warning conditions on its $\overline{\text{TWR}}$, $\overline{\text{ERROC}}$, and $\overline{\text{ERRUVTE}}$ pins.

- The $\overline{\text{TWR}}$ pin indicates the presence of a thermal warning condition. When active concurrently with the $\overline{\text{ERRUVTE}}$ pin, indicates a thermal error condition.
- The $\overline{\text{ERROC}}$ pin indicates the presence of an over-current condition on one or both of the output channels.
- The $\overline{\text{ERRUVTE}}$ pin indicates the presence of a VP undervoltage condition. When active concurrently with the $\overline{\text{TWR}}$ pin, indicates a thermal error condition.

The trigger point for each warning and error condition is defined in the [PWM Power Output Characteristics](#) table on [page 20](#). Each pin implements an active-low open-drain driver and requires an external pull-up for proper operation.

6.2.6 Thermal Foldback

In hardware mode, the CS4525 implements a thermal foldback feature to guard against damaging thermal overload conditions. The thermal foldback feature begins limiting the volume of the digital audio input to the amplifier stage as the junction temperatures rise above the maximum safe operating range specified by the thermal warning trigger point listed in the [PWM Power Output Characteristics](#) table on [page 20](#). This effectively limits the output power capability of the device, thereby allowing the temperature to reduce to acceptable levels without fully interrupting operation. As the device cools, the applied attenuation is gradually released until a new thermal equilibrium is reached or all applied attenuation has been released thereby allowing the device to again achieve its full output power capability.

Attenuation applied due to thermal foldback reduces the audio output level in a linear manner. [Figure 18](#) below demonstrates the foldback process.

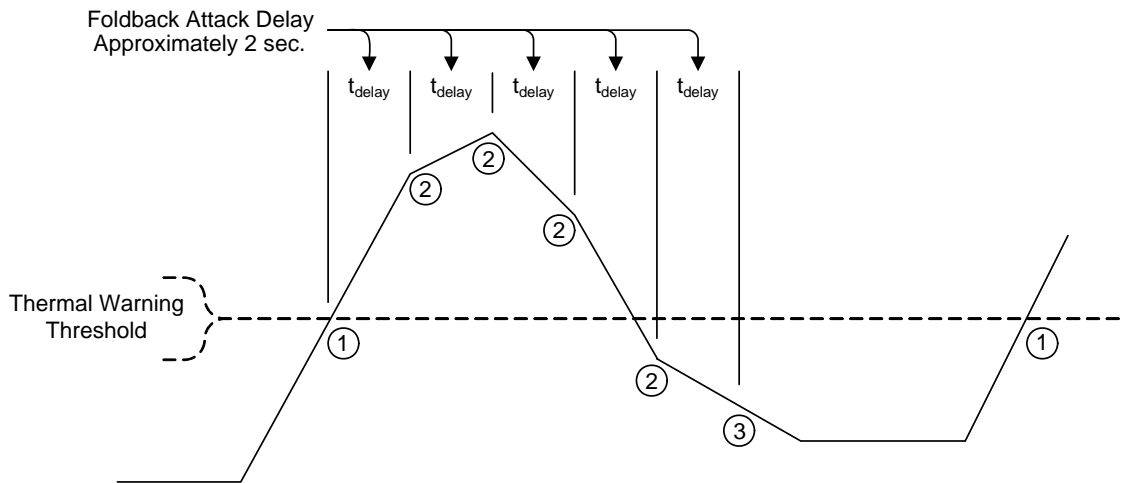

- ① When the junction temperature crosses the thermal warning threshold, the foldback attack delay timer is started.
- ② When the foldback attack delay timer reaches t_{delay} seconds, the junction temperature is checked. If it is above the thermal warning threshold, the output volume level is lowered by 0.5 dB and the foldback attack timer is restarted.
The junction temperature is checked after each foldback attack timer timeout, and if necessary, the output volume level is lowered accordingly.
- ③ The junction temperature is checked once again after the next foldback attack timer timeout. If it has remained below the thermal warning threshold since the last check, the device will begin to release any attenuation applied as a result of the foldback event.

If the junction temperature crosses the thermal warning threshold again, the foldback algorithm will once again enter step 1.

Figure 25. Foldback Process

Thermal warning conditions will only affect the foldback algorithm and cause attenuation to be applied if enabled by the EN_TFB pin as shown in [Table 16](#) below.

EN_TFB	Selected Thermal Foldback Enable State
Low	Thermal foldback disabled.
High	Thermal foldback enabled.

Table 16. Thermal Foldback Enable Selection

6.2.7 Automatic Power Stage Shut-Down

To protect itself from permanent damage, the CS4525 will automatically shut down its internal PWM power output stages when a thermal error, PWM power output over-current error, or VP under-voltage condition occurs. In the shut-down state, all digital functions of the device will operate as normal, however the PWM power output pins become high-impedance.

The levels of the over-current error, thermal error, and VP under-voltage trigger points are listed in the [PWM Power Output Characteristics](#) table on [page 20](#). Shut-down will occur automatically whenever the preset thresholds for thermal error or under-voltage are crossed.

When the over-current threshold is crossed, the CS4525 will attempt to automatically resume power output operation after an over-current error is encountered and before placing its PWM power outputs in the shut-down state. Upon the detection of an over-current condition, the CS4525 will place the PWM power outputs in a high-impedance state, wait approximately 85 ms, and then re-engage the power outputs in an attempt to resume normal operation. If another over-current condition is immediately detected, the PWM power outputs will again be placed in a high-impedance state before retrying to resume normal operation a second time. It will continue this sequence for a maximum of five attempts. After the fifth unsuccessful attempt, the outputs will remain in the high-impedance shut-down state.

Once in the shut-down state, the $\overline{\text{RST}}$ signal must be toggled low and then high to resume normal device operation.

6.3 PWM Modulators and Sample Rate Converters

The CS4525 includes three PWM modulators and three corresponding sample rate converters, each clocked from the external crystal or system clock applied at power-up. All three modulator and sample rate converter pairs are available in software mode (see [Figure 14 on page 29](#)), and two pairs are used in hardware mode (see [Figure 24 on page 56](#)).

One of the characteristics of a PWM modulator is that the frequency content of the out-of-band noise generated is dependent on the PWM switching frequency. As the power stage external LC and snubber filter component values are used to attenuate this out-of band energy, their component values are also based on this switching frequency.

To easily accommodate input sample rates ranging from 32 kHz to 96 kHz without requiring the adjustment of output filter component values, the CS4525 utilizes a sample rate converter (SRC) to keep the PWM switching frequency fixed regardless of the input sample rate. The SRC operates by upsampling the variable input sample rate to a fixed output switching rate, typically 384 kHz for most audio applications. [Table 17](#) below shows the PWM output switching rate and quantization levels as a function of the supplied external crystal or system clock.

Additionally, as the output of the SRC is clocked from a very stable crystal or oscillator, the SRC also allows the PWM modulator output to be independent of the input serial audio clock jitter. This results in very low jitter PWM output and higher dynamic range.

Supplied XTAL or SYS_CLK Frequency	PWM Switch Rate	Quantization Levels
18.432 MHz	384 kHz	48
24.576 MHz	384 kHz	64
27.000 MHz	421.875 kHz	64

Table 17. PWM Output Switching Rates and Quantization Levels

6.4 Output Filters

The filter placed after the PWM outputs can greatly affect the output performance. The filter not only reduces radiated EMI (snubber filter), but also filters high frequency content from the switching output before going to the speaker (low-pass LC filter).

6.4.1 Half-Bridge Output Filter

Figure 26 shows the output filter for a half-bridge configuration. The transient-voltage suppression circuit (snubber circuit) is comprised of a capacitor (680 pF) and a resistor (5.6 Ω, 1/8 W) and should be placed as close as possible to the corresponding PWM output pin to greatly reduce radiated EMI.

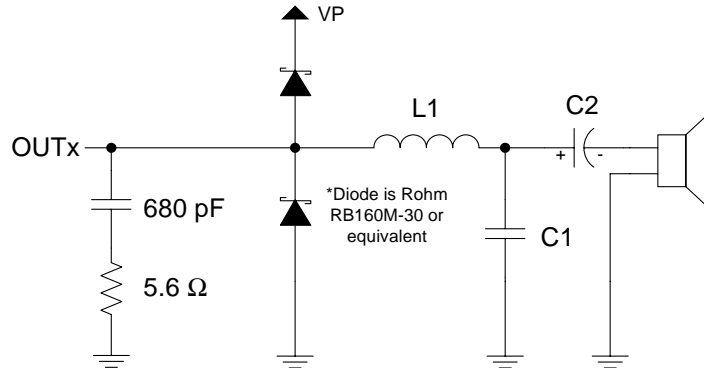

Figure 26. Output Filter - Half-Bridge

The inductor, L1, and capacitor, C1, comprise the low-pass filter. Along with the nominal load impedance of the speaker, these values set the cutoff frequency of the filter. Table 18 shows the component values for L1 and C1 based on nominal speaker (load) impedance for a corner frequency (-3 dB point) of approximately 35 kHz.

Load	L1	C1
4 Ω	22 μH	1.0 μF
6 Ω	33 μH	0.68 μF
8 Ω	47 μH	0.47 μF

Table 18. Low-Pass Filter Components - Half-Bridge

C2 is the DC-blocking capacitor. Table 19 shows the component values for C2 based on corner frequency (-3 dB point) and a nominal speaker (load) impedances of 4 Ω, 6 Ω, and 8 Ω. This capacitor should also be chosen to have a ripple current rating above the amount of current that will be passed through it.

Load	Corner Frequency	C2
4 Ω	40 Hz	1000 μF
	58 Hz	680 μF
	120 Hz	330 μF
6 Ω	39 Hz	680 μF
	68 Hz	390 μF
	120 Hz	220 μF
8 Ω	42 Hz	470 μF
	60 Hz	330 μF
	110 Hz	180 μF

Table 19. DC-Blocking Capacitors Values - Half-Bridge

6.4.2 Full-Bridge Output Filter (Stereo or Parallel)

Figure 27 shows the output filter for a full-bridge configuration. The transient-voltage suppression circuit (snubber circuit) is comprised of a capacitor (680 pF) and a resistor (5.6 Ω, 1/8 W) on each output pin and should be placed as close as possible to the corresponding PWM output pins to greatly reduce radiated EMI. The inductors, L1, and capacitor, C1, comprise the low-pass filter. Along with the nominal load impedance of the speaker, these values set the cutoff frequency of the filter. Table 20 shows the component values based on nominal speaker (load) impedance for a corner frequency (-3 dB point) of approximately 35 kHz.

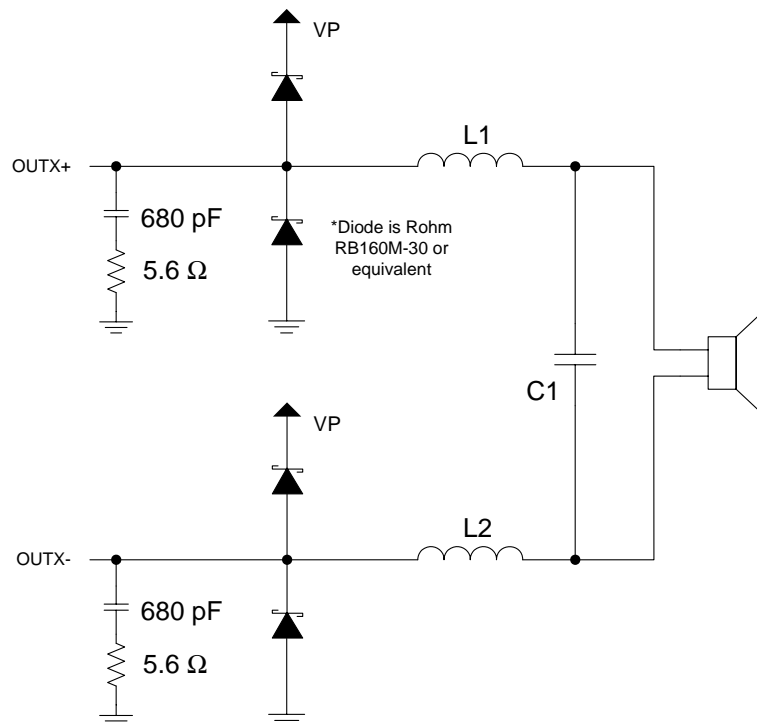

Figure 27. Output Filter - Full-Bridge

Load	L1, L2	C1
4 Ω	10 μH	1.0 μF
6 Ω	15 μH	0.47 μF
8 Ω	22 μH	0.47 μF

Table 20. Low-Pass Filter Components - Full-Bridge

6.5 Analog Inputs

Very few components are required to interface between the audio source and the CS4525's analog inputs, AINL and AINR. A single order passive low-pass filter is recommended to prevent high-frequency content from aliasing into the audio band due to the analog-to-digital conversion process. Also, a DC-blocking capacitor is required as the CS4525's analog inputs are internally biased to V_Q.

The recommended analog input circuit is shown in [Figure 28](#) below will accommodate full-scale input voltages as defined in the [Analog Input Characteristics](#) table on [page 19](#). This circuit provides the necessary high-frequency filtering with a first-order passive low-pass filter that has less than 0.05 dB of attenuation at 24 kHz. It also includes a DC blocking capacitor to accommodate the analog input pins' bias level.

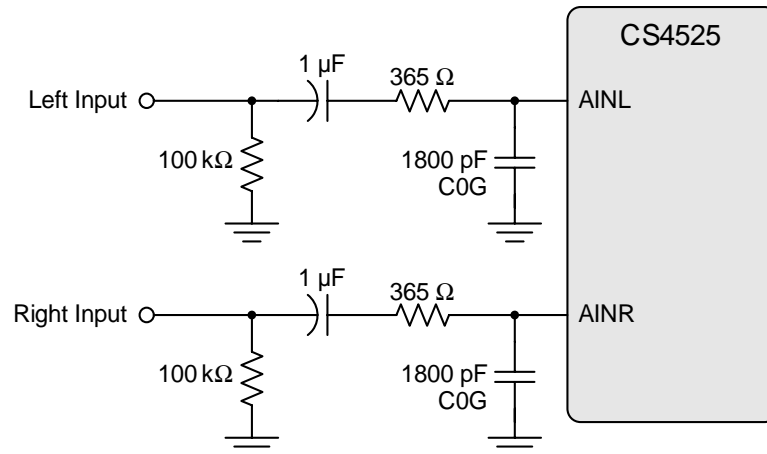

Figure 28. Recommended Unity Gain Input Filter

To interface 2 V_{RMS} input signals with the CS4525's analog inputs, an external resistor divider is required. [Figure 29](#) shows the recommended input circuit for 2 V_{RMS} inputs. It includes a -8.4 dB passive attenuator to condition the input signal for the CS4525's full-scale input voltage, a first-order passive low-pass filter that has less than 0.05 dB of attenuation at 24 kHz, and a DC blocking capacitor to accommodate for the analog input pins' bias level. The passive attenuator network should be placed as close as possible to the CS4525's analog input pins to reduce the potential for noise and signal coupling into the analog input traces.

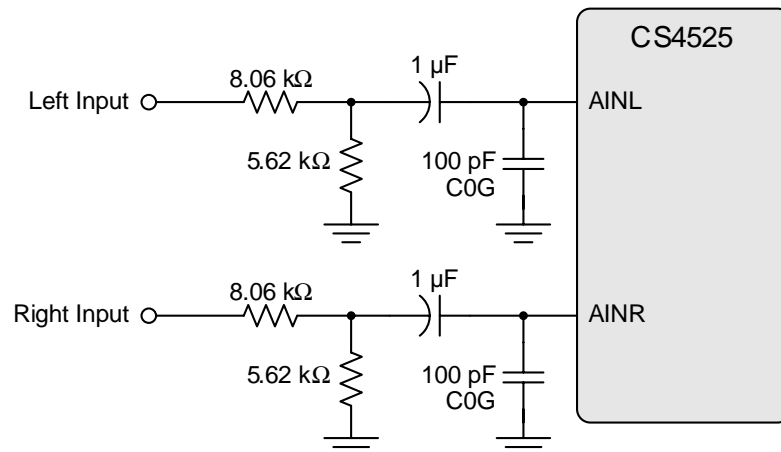

Figure 29. Recommended 2 V_{RMS} Input Filter

It should be noted that the external DC blocking capacitor forms a high-pass filter with the CS4525's input impedance. Both filters shown above have less than 0.2 dB attenuation at 20 Hz due to this effect. Increasing the value of this capacitor will lower this high-pass corner frequency, and decreasing its value will increase the corner frequency.

6.6 Serial Audio Interfaces

The CS4525 interfaces to external digital audio devices via the serial audio input port and the auxiliary/delay serial ports.

The serial audio input port provides support for I²S, Left-Justified and Right-Justified data formats and operates in slave mode only, with LRCK and SCLK as inputs. The input LRCK signal must be equal to the sample rate, Fs and must be synchronous to the serial bit clock, SCLK, which is used to sample the data bits.

The auxiliary/delay serial port (available in software mode only) supports I²S and Left-Justified data formats and operates in master mode only, with AUX_LRCK and AUX_SCLK as outputs.

Each of the supported formats is described in detail in sections 6.6.1 - 6.6.3 below. Please refer to the [Serial Audio Input Port Switching Specifications](#) and [AUX Serial Audio I/O Port Switching Specifications](#) on page 21 and page 22 (respectively) for the precise timing and tolerances of each signal.

For additional information, application note AN282 presents a tutorial of the 2-channel serial audio interface. AN282 can be downloaded from the Cirrus Logic web site at <http://www.cirrus.com>.

6.6.1 I²S Data Format

In I²S format, data is received most significant bit first one SCLK delay after the transition of LRCK and is valid on the rising edge of SCLK. The left channel data is presented when LRCK is low; the right channel data is presented when LRCK is high.

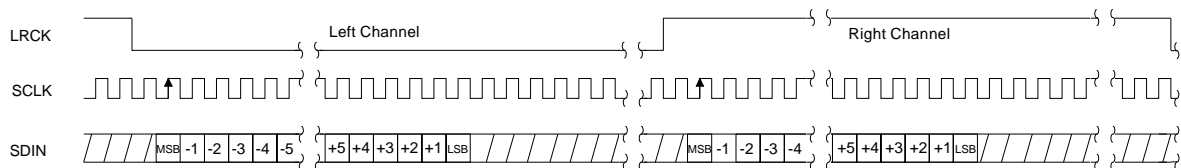

Figure 30. I²S Serial Audio Formats

6.6.2 Left-Justified Data Format

In Left-Justified format, data is received most significant bit first on the first SCLK after a LRCK transition and is valid on the rising edge of SCLK. The left channel data is presented when LRCK is high and the right channel data is presented when LRCK is low.

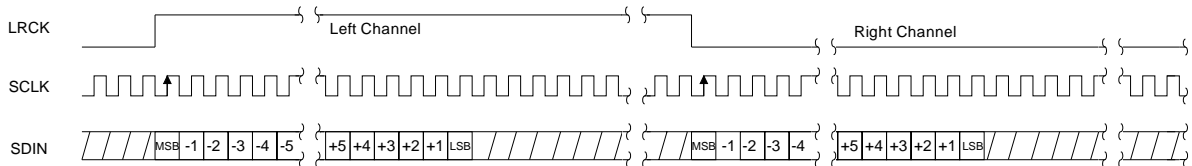

Figure 31. Left-Justified Serial Audio Formats

6.6.3 Right-Justified Data Format

In Right-Justified format, data is received most significant bit first and with the least significant bit presented on the last SCLK before the LRCK transition and is valid on the rising edge of SCLK. For the Right-Justified format, the left channel data is presented when LRCK is high and the right channel data is presented when LRCK is low. 16, 18, 20, and 24 bits per sample are supported.

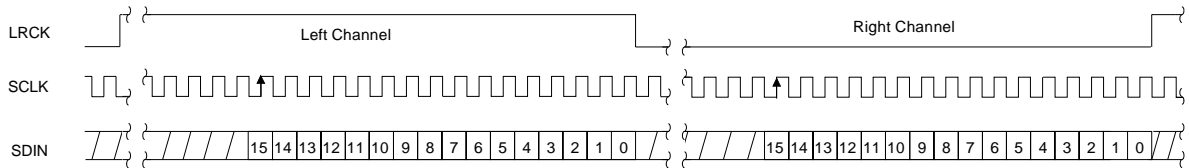

Figure 32. Right-Justified Serial Audio Formats

6.7 Integrated VD Regulator

The CS4525 includes two internal linear regulators, one from the VD supply voltage to provide a fixed 2.5 V supply to its internal digital blocks, and another from the VD supply voltage to provide a fixed 2.5 V supply to its internal analog blocks. The LVD pin must be set to indicate the voltage present on the VD pin as shown in Table 21 below.

VD Connection	VD_REG Connection	VA_REG Connection	LVD Connection	SelectVD Bit Setting Software Mode Only
5 V Supply	Bypass Capacitors Only	Bypass Capacitors Only	VD	'1' - Default
3.3 V Supply	Bypass Capacitors Only	Bypass Capacitors Only	DGND	'1' - Default
2.5 V Supply	VD and Bypass Capacitors	VD and Bypass Capacitors	DGND	'0'

Table 21. Power Supply Configuration and Settings

The output of the digital regulator is presented on the VD_REG pin and may be used to provide an external device with up to 3 mA of current at its nominal output voltage of 2.5 V. The output of the analog regulator is presented on the VA_REG pin and must only be connected to the bypass capacitors as shown in the typical connection diagrams.

If a nominal supply voltage of 2.5 V is used as the VD supply (see the [Recommended Operating Conditions](#) table on page 18), the VD, VD_REG, and VA_REG pins must all be connected to the VD supply source. In this configuration, the internal regulators are bypassed and the external supply source is used to directly drive the internal digital and analog sections.

Referenced Control	Register Location
SelectVD	"Select VD Level (SelectVD)" on page 88

6.8 I²C Control Port Description and Timing

The control port is used to access the registers allowing the CS4525 to be configured for the desired operational modes and formats. The operation of the control port may be completely asynchronous with respect to the audio sample serial port. However, to avoid potential interference problems, the control port pins should remain static if no operation is required. The control port operates in I²C Mode, with the CS4525 acting as a slave device.

SDA is a bidirectional data line. Data is clocked into and out of the part by the clock, SCL. A 47 kΩ pull-up or pull-down on the AUX_LRCK/AD0 pin will set AD0, the least significant bit of the device address. A pull-up to VD will set AD0 to '1' and a pull-down to DGND will set AD0 to '0'. The state of AUX_LRCK/AD0 is sensed, and AD0 is set upon the release of **RESET**.

The signal timings for a read and write cycle are shown in [Figure 33](#) and [Figure 34](#). A Start condition is defined as a falling transition of SDA while the clock is high. A Stop condition is a rising transition while the clock is high. All other transitions of SDA occur while the clock is low. The first byte sent to the CS4525 after a Start condition consists of a 7 bit device address field and a R/W bit (high for a read, low for a write). The upper 6 bits of the 7-bit address field are fixed at 100101. To communicate with a CS4525, the device address field, which is the first byte sent to the CS4525, should match 100101 followed by the setting of AD0. The eighth bit of the address is the R/W bit. If the operation is a write, the next byte is the memory address pointer (MAP) which selects the register to be read or written. If the operation is a read, the contents of the register pointed to by the MAP will be output. Setting the auto increment bit in MAP allows successive reads or writes of consecutive registers. Each byte is separated by an acknowledge bit. The ACK bit is output from the CS4525 after each input byte is read, and is input to the CS4525 from the microcontroller after each transmitted byte.

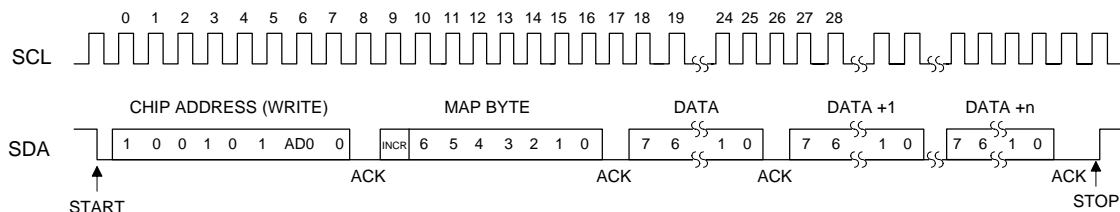

Figure 33. Control Port Timing, I²C Write

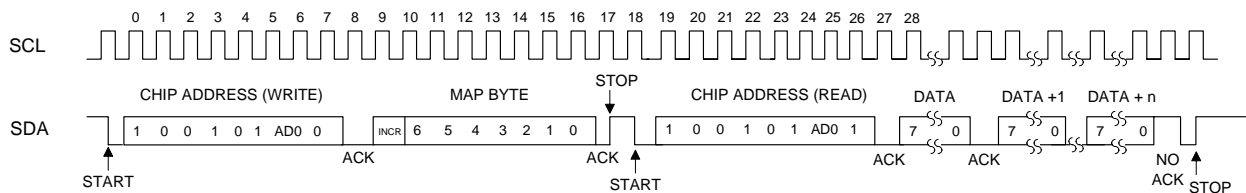

Figure 34. Control Port Timing, I²C Read

Since the read operation can not set the MAP, an aborted write operation is used as a preamble. As shown in [Figure 34](#), the write operation is aborted after the acknowledge for the MAP byte by sending a stop condition. The following pseudocode illustrates an aborted write operation followed by a read operation.

- Send start condition.
- Send 100101x0 (device address and write operation).
- Receive acknowledge bit.
- Send MAP byte, auto increment off.
- Receive acknowledge bit.
- Send stop condition, aborting write. (Optional.)
- Send start condition.
- Send 100101x1 (device address and read operation).

Receive acknowledge bit.
Receive byte, contents of selected register.
Send acknowledge bit.
Send stop condition. (Optional.)

Setting the auto increment bit in the MAP allows successive reads or writes of consecutive registers. Each byte is separated by an acknowledge bit.

7. PCB LAYOUT CONSIDERATIONS

7.1 Power Supply, Grounding

As with any high-resolution converter, the CS4525 requires careful attention to power supply and grounding arrangements if its potential performance is to be realized.

Extensive use of power and ground planes, ground plane fill in unused areas and surface mount decoupling capacitors are recommended. Decoupling capacitors should be as close to the pins of the CS4525 as possible. The lowest value ceramic capacitor should be closest to the pin and should be mounted on the same side of the board as the CS4525 to minimize inductance effects. All signals, especially clocks, should be kept away from the FILT+ and VQ pins in order to avoid unwanted coupling into the modulators. The FILT+ and VQ decoupling capacitors, particularly the 0.1 μF , must be positioned to minimize the electrical path from FILT+ and AGND. The CRD4525 reference design demonstrates the optimum layout and power supply arrangements.

7.2 QFN Thermal Pad

The CS4525 is available in a compact QFN package. The underside of the QFN package reveals a large metal pad that serves as a thermal relief to provide for maximum heat dissipation. This pad must mate with an equally dimensioned copper pad on the PCB and must be electrically connected to ground. A series of thermal vias should be used to connect this copper pad to one or more larger ground planes on other PCB layers. The CRD4525 reference design demonstrates the optimum thermal pad and via configuration.

For more information concerning thermal considerations of QFN packages, please refer to Cirrus Logic application note AN315.

8. REGISTER QUICK REFERENCE

This table shows the register names and their associated default values.

Adr	Name	7	6	5	4	3	2	1	0
01h	Clock Config page 69	EnSysClk 1	DivSysClk 0	ClkFreq1 0	ClkFreq0 1	HP/MutePol 0	HP/Mute 0	PhaseShift 0	FreqShift 0
02h	Input Config page 71	ADC/SP 0	EnAnHPF 1	Reserved 0	SPRate1 x	SPRate0 x	DIF2 0	DIF1 0	DIF0 0
03h	Aux Config page 72	EnAuxPort 0	DlyPortCfg1 0	DlyPortCfg0 0	AuxI ² S/LJ 0	RChDSel1 0	RChDSel0 1	LChDSel1 0	LChDSel0 0
04h	Output Cfg page 73	OutputCfg1 0	OutputCfg0 0	PWMDSel1 0	PWMDSel0 0	OutputDly3 0	OutputDly2 0	OutputDly1 0	OutputDly0 0
05h	Foldback Cfg page 74	SelectVP 1	EnTherm 0	LockAdj 0	AttackDly1 0	AttackDly0 1	EnFloor 0	RmpSpd1 1	RmpSpd0 1
06h	Mixer Config page 75	PreScale2 0	PreScale1 0	PreScale0 0	Reserved 0	RChMix1 0	RChMix0 0	LChMix1 0	LChMix0 0
07h	Tone Config page 76	DeEmph 0	Loudness 0	EnDigHPF 0	TrebFc1 0	TrebFc0 0	BassFc1 0	BassFc0 1	EnToneCtrl 0
08h	Tone Control page 78	Treble3 1	Treble2 0	Treble1 0	Treble0 0	Bass3 1	Bass2 0	Bass1 0	Bass0 0
09h	EQ Config page 78	Freeze 0	HiZPSig 0	BassMgr2 0	BassMgr1 0	BassMgr0 0	Reserved 0	EnChBPEq 0	EnChAPEq 0
0Ah 0Bh 0Ch	BiQuad 1 A1 Coeff	MSB MSB-8 LSB+7						MSB-7 LSB+8 LSB
0Dh 0Eh 0Fh	BiQuad 1 A2 Coeff	MSB MSB-8 LSB+7						MSB-7 LSB+8 LSB
10h 11h 12h	BiQuad 1 B0 Coeff	MSB MSB-8 LSB+7						MSB-7 LSB+8 LSB
13h 14h 15h	BiQuad 1 B1 Coeff	MSB MSB-8 LSB+7						MSB-7 LSB+8 LSB
16h 17h 18h	BiQuad 1 B2 Coeff	MSB MSB-8 LSB+7						MSB-7 LSB+8 LSB
19h 1Ah 1Bh	BiQuad 2 A1 Coeff	MSB MSB-8 LSB+7						MSB-7 LSB+8 LSB
1Ch 1Dh 1Eh	BiQuad 2 A2 Coeff	MSB MSB-8 LSB+7						MSB-7 LSB+8 LSB
1Fh 20h 21h	BiQuad 2 B0 Coeff	MSB MSB-8 LSB+7						MSB-7 LSB+8 LSB
22h 23h 24h	BiQuad 2 B1 Coeff	MSB MSB-8 LSB+7						MSB-7 LSB+8 LSB

Adr	Name	7	6	5	4	3	2	1	0
25h	BiQuad 2 B2 Coeff	MSB	MSB-7
26h		MSB-8	LSB+8
27h		LSB+7	LSB
28h	BiQuad 3 A1 Coeff	MSB	MSB-7
29h		MSB-8	LSB+8
2Ah		LSB+7	LSB
2Bh	BiQuad 3 A2 Coeff	MSB	MSB-7
2Ch		MSB-8	LSB+8
2Dh		LSB+7	LSB
2Eh	BiQuad 3 B0 Coeff	MSB	MSB-7
2Fh		MSB-8	LSB+8
30h		LSB+7	LSB
31h	BiQuad 3 B1 Coeff	MSB	MSB-7
32h		MSB-8	LSB+8
33h		LSB+7	LSB
34h	BiQuad 3 B2 Coeff	MSB	MSB-7
35h		MSB-8	LSB+8
36h		LSB+7	LSB
37h	BiQuad 4 A1 Coeff	MSB	MSB-7
38h		MSB-8	LSB+8
39h		LSB+7	LSB
3Ah	BiQuad 4 A2 Coeff	MSB	MSB-7
3Bh		MSB-8	LSB+8
3Ch		LSB+7	LSB
3Dh	BiQuad 4 B0 Coeff	MSB	MSB-7
3Eh		MSB-8	LSB+8
3Fh		LSB+7	LSB
40h	BiQuad 4 B1 Coeff	MSB	MSB-7
41h		MSB-8	LSB+8
42h		LSB+7	LSB
43h	BiQuad 4 B2 Coeff	MSB	MSB-7
44h		MSB-8	LSB+8
45h		LSB+7	LSB
46h	BiQuad 5 A1 Coeff	MSB	MSB-7
47h		MSB-8	LSB+8
48h		LSB+7	LSB
49h	BiQuad 5 A2 Coeff	MSB	MSB-7
4Ah		MSB-8	LSB+8
4Bh		LSB+7	LSB
4Ch	BiQuad 5 B0 Coeff	MSB	MSB-7
4Dh		MSB-8	LSB+8
4Eh		LSB+7	LSB
4Fh	BiQuad 5 B1 Coeff	MSB	MSB-7
50h		MSB-8	LSB+8
51h		LSB+7	LSB
52h	BiQuad 5 B2 Coeff	MSB	MSB-7
53h		MSB-8	LSB+8
54h		LSB+7	LSB

Adr	Name	7	6	5	4	3	2	1	0
55h	Volume Cfg page 80	SZCMode1 1	SZCMode0 0	Mute50/50 0	AutoMute 1	En2Way 0	2WayFreq2 0	2WayFreq1 0	2WayFreq0 0
56h	Sensitivity page 81	LowPass3 0	LowPass2 0	LowPass1 0	LowPass0 0	HighPass3 0	HighPass2 0	HighPass1 0	HighPass0 0
57h	Master Vol page 82	MVol7 0	MVol6 0	MVol5 1	MVol4 0	MVol3 1	MVol2 0	MVol1 1	MVol0 0
58h	Ch A Vol page 83	ChAVol7 0	ChAVol6 0	ChAVol5 1	ChAVol4 1	ChAVol3 0	ChAVol2 0	ChAVol1 0	ChAVol0 0
59h	Ch B Vol page 83	ChBVol7 0	ChBVol6 0	ChBVol5 1	ChBVol4 1	ChBVol3 0	ChBVol2 0	ChBVol1 0	ChBVol0 0
5Ah	Sub Vol page 83	SubVol7 0	SubVol6 0	SubVol5 1	SubVol4 1	SubVol3 0	SubVol2 0	SubVol1 0	SubVol0 0
5Bh	Mute Control page 84	InvADC 0	InvSub 0	InvCh2 0	InvCh1 0	MuteADC 0	MuteSub 0	MuteChB 0	MuteChA 0
5Ch	Limiter Cfg 1 page 85	Max2 0	Max1 0	Max0 0	Min2 0	Min1 0	Min0 0	LimitAll 1	EnLimiter 0
5Dh	Limiter Cfg 2 page 87	Reserved 0	Reserved 0	RRate5 1	RRate4 1	RRate3 1	RRate2 1	RRate1 1	RRate0 1
5Eh	Limiter Cfg 3 page 87	EnThLim 0	Reserved 0	ARate5 0	ARate4 0	ARate3 0	ARate2 0	ARate1 0	ARate0 0
5Fh	Power Ctrl page 88	AutoRetry 1	EnOCProt 1	SelectVD 1	PDnADC 1	PDnOut3/4 1	PDnOut2 1	PDnOut1 1	PDnAll 1
60h	Interrupt page 89	SRCLock x	ADCOvfl x	ChOvfl x	AmpErr x	SRCLockM 0	ADCOvflM 0	ChOvflM 0	AmpErrM 0
61h	Int Status page 92	SRCLockSt x	ADCOvflSt x	SubOvflSt x	Ch2OvflSt x	Ch1OvflSt x	RampDone x	Reserved 0	Reserved 0
62h	Amp Error page 93	OverCurr4 x	OverCurr3 x	OverCurr2 x	OverCurr1 x	ExtAmpSt x	Reserved 0	UVTE1 x	UVTE0 x
63h	Device ID page 94	DeviceID4 1	DeviceID3 1	DeviceID2 1	DeviceID1 1	DeviceID0 1	RevID2 x	RevID1 x	RevID0 x

9. REGISTER DESCRIPTIONS

All registers are read/write unless otherwise stated. All “Reserved” bits must maintain their default state.

9.1 Clock Configuration (Address 01h)

7	6	5	4	3	2	1	0
EnSysClk	DivSysClk	ClkFreq1	ClkFreq0	HP/MutePol	HP/Mute	PhaseShift	FreqShift

9.1.1 SYS_CLK Output Enable (EnSysClk)

Default = 1

Function:

This bit controls the output driver for the SYS_CLK signal. When cleared, the output driver is disabled and the SYS_CLK pin is high-impedance. When set, the output driver is enabled.

If the SYS_CLK output is unused, this bit should be set to ‘0’b to disable the driver.

EnSysClk Setting	Output Driver State
0	Output driver disabled.
1	Output driver enabled.

9.1.2 SYS_CLK Output Divider (DivSysClk)

Default = 0

Function:

This bit determines the divider for the XTAL clock signal for generating the SYS_CLK signal.

This divider is only available if the clock source is an external crystal attached to XTI/XTO and the SYS_CLK output is enabled.

DivSysClk Setting	SYS_CLK Output Frequency
0	$F_{SYS_CLK} = F_{XTAL}$
1	$F_{SYS_CLK} = F_{XTAL}/2$

9.1.3 Clock Frequency (ClkFreq[1:0])

Default = 01

Function:

These bits must be set to identify the nominal clock frequency of the crystal attached to the XTI/XTO pins or that of the input SYS_CLK signal. See the [XTI Switching Specifications](#) table on [page 23](#) and the [SYS_CLK Switching Specifications](#) table on [page 23](#) for complete input frequency range specifications.

ClkFreq[1:0] Setting	Specified Nominal Input Clock Frequency
00	18.432 MHz
01	24.576 MHz
10	27.000 MHz
11	Reserved

9.1.4 **HP_Detect/Mute Pin Active Logic Level (HP/MutePol)**

Default = 0

Function:

This bit determines the active logic level for the HP_DETECT/MUTE input signal.

HP/MutePol Setting	Headphone Detect/Mute Input Polarity
0	Active low.
1	Active high.

9.1.5 **HP_Detect/Mute Pin Mode (HP/Mute)**

Default = 0

Function:

Configures the function of HP_DETECT/MUTE input pin. See [“Headphone Detection & Hardware Mute Input” on page 51](#) for more information.

HP/Mute Setting	HP_DETECT/MUTE Pin Function
0	Mute input signal.
1	Headphone detect input signal.

9.1.6 **Modulator Phase Shifting (PhaseShift)**

Default = 0

Function:

When enabled, forces the output of the PWM modulator to output differential signals which are the inverse of each other and have been phase shifted by 180 degrees. This causes, for instance, the differential signal pair to be exactly in phase with one another during a mute condition, thereby reducing the amount of switching current through the load.

PhaseShift Setting	Modulator Phase Shift State
0	180° phase shift disabled.
1	180° phase shift enabled.

9.1.7 **AM Frequency Shifting (FreqShift)**

Default = 0

Function:

Controls the state of the PWM AM frequency shift feature. See [“PWM AM Frequency Shift” on page 51](#) for more information.

FreqShift Setting	AM Frequency Shift State
0	Frequency shift disabled.
1	Frequency shift enabled.

9.2 Input Configuration (Address 02h)

7	6	5	4	3	2	1	0
ADC/SP	EnAnHPF	Reserved	SPRate1	SPRate0	DIF2	DIF1	DIF0

9.2.1 Input Source Selection ($\overline{\text{ADC/SP}}$)

Default = 0

Function:

This bit selects the audio input source.

ADC/SP Setting	Audio Input Source
0	Digital input from the serial audio input port.
1	Analog input from the internal ADC.

9.2.2 ADC High-Pass Filter Enable (*EnAnHPF*)

Default = 1

Function:

Controls the operation of the ADC high-pass filter.

EnAnHPF Setting	ADC High-Pass Filter State
0	ADC high-pass filter disabled.
1	ADC high-pass filter enabled.

9.2.3 Serial Port Sample Rate (*SPRate[1:0]*) - Read Only

Function:

Identifies the sample rate of the incoming LRCK signal on the serial audio input port based on the setting of the ClkFreq[1:0] bits in Register 01h, the frequency of the internal system clock, and the frequency of the input LRCK signal.

SPRate[1:0] Setting	Identified Input Sample Rate
00	32 kHz
01	44.1 kHz
10	48 kHz
11	96 kHz

9.2.4 Input Serial Port Digital Interface Format (*DIF [2:0]*)

Default = 000

Function:

Selects the serial audio interface format used for the data in on SDIN. The required relationship between the Left/Right clock, serial clock and serial data is defined by the Digital Interface Format and the options are detailed in the section “Serial Audio Interfaces” on page 62.

DIF[2:0] Setting	Input Serial Port Serial Audio Interface Format
000	Left-Justified, up to 24-bit data.
001	I ² S, up to 24-bit data.
010	Right-Justified, 24-bit data.
011	Right-Justified, 20-bit data.
100	Right-Justified, 18-bit data.
101	Right-Justified, 16-bit data.
110	Reserved.
111	Reserved.

9.3 AUX Port Configuration (Address 03h)

7	6	5	4	3	2	1	0
EnAuxPort	DlyPortCfg1	DlyPortCfg0	AuxI ² S/LJ	RChDSel1	RChDSel0	LChDSel1	LChDSel0

9.3.1 Enable Aux Serial Port (EnAuxPort)

Default = 0

Function:

Controls the operation of the auxiliary serial port.

EnAuxPort Setting	Auxiliary Port State
0	Auxiliary port disabled.
1	Auxiliary port enabled.

9.3.2 Delay & Warning Port Configuration (DlyPortCfg[1:0])

Default = 00

Function:

Controls the operation of the delay and warning port. See [“Serial Audio Delay & Warning Input Port”](#) on page 44 for more information.

DlyPortCfg[1:0] Setting	Delay Port Configuration
00	Port disabled.
01	Port configured as serial audio delay interface.
10	Port configured as an external thermal warning indicator for the foldback algorithm.
11	Port disabled.

9.3.3 Aux/Delay Serial Port Digital Interface Format (AuxI²S/LJ)

Default = 0

Function:

Selects the serial audio interface format for the data on AUX_SDO_{UT}, DLY_SDIN, DLY_SDO_{UT}. The required relationship between the Left/Right clock, serial clock and serial data is defined by the Digital Interface Format and the options are detailed in the [“Serial Audio Interfaces”](#) on page 62.

AuxI ² S/LJ Setting	Auxiliary/Delay Port Serial Audio Interface Format
0	Left-Justified, up to 24-bit.
1	I ² S, up to 24-bit.

9.3.4 Aux Serial Port Right Channel Data Select (RChDSel[1:0])

Default = 01

Function:

Selects the data to be sent over the right channel of the auxiliary port serial data output signal.

RChDSel[1:0] Setting	Aux Serial Port Right Channel Output Data Source
00	Channel A.
01	Channel B.
10	Sub Channel.
11	Channel B crossover high-pass output.

9.3.5 Aux Serial Port Left Channel Data Select (LChDSel[1:0])

Default = 00

Function:

Selects the data to be sent over the left channel of the auxiliary port serial data output signal.

LChDSel[1:0] Setting	Aux Serial Port Left Channel Output Data Source
00	Channel A.
01	Channel B.
10	Sub Channel.
11	Channel B crossover low-pass output.

9.4 Output Configuration (Address 04h)

7	6	5	4	3	2	1	0
OutputCfg1	OutputCfg0	PWMDSel1	PWMDSel0	OutputDly3	OutputDly2	OutputDly1	OutputDly0

9.4.1 Output Configuration (OutputCfg[1:0])

Default = 00

Function:

Identifies the power output configuration. This parameter can only be changed when all modulators and associated logic are in the power-down state (the PDnAll bit is set). Attempts to write this register while the PDnAll is cleared will be ignored. See [“Output Channel Configurations” on page 45](#) for more information.

OutputCfg[1:0] Setting	Power Output Configuration
00	Channel 1 & 2 Full-Bridge.
01	Channel 1 & 2 Half-Bridge + Sub Channel Full-Bridge.
10	Channel 1 Parallel Full-Bridge.
11	Reserved.

9.4.2 PWM Signals Output Data Select (PWMDSel[1:0])

Default = 00

Function:

Selects the PWM data output on the PWM_SIG1 and PWM_SIG2 output signals. See [“PWM_SIG Logic-Level Output Configurations” on page 49](#) for more information.

PWMDSel Setting	PWM Signal Output Mapping
00	PWM_SIG1 output disabled. PWM_SIG2 output disabled.
01	Channel 1 output on PWM_SIG1. Channel 2 output on PWM_SIG2.
10	Channel 1 output on PWM_SIG1. Sub Channel output on PWM_SIG2.
11	Channel 2 output on PWM_SIG1. Sub Channel output on PWM_SIG2.

9.4.3 Channel Delay Settings (OutputDly[3:0])

Default = 0000

Function:

The channel delay bits allow delay adjustment of each of the power output audio channels. The value of this register determines the amount of delay inserted in the output path. The delay time is calculated by multiplying the register value by the period of the SYS_CLK or crystal input clock source. These bits can

only be changed while all modulators and associated logic are in the power-down state (the PDnAll bit is set). Attempts to write these bits while the PDnAll bit is cleared will be ignored. See [“PWM Channel Delay” on page 55](#) for more information.

OutputDly[3:0] Setting	Output Delay in Input Clock Source Cycles
0000	0 - No Delay
0001	1
0010	2
.....	
1000	8
.....	
1111	15 - Max Delay

9.5 Foldback and Ramp Configuration (Address 05h)

7	6	5	4	3	2	1	0
SelectVP	EnTherm	LockAdj	AttackDly1	AttackDly0	EnFloor	RmpSpeed1	RmpSpeed0

9.5.1 Select VP Level (SelectVP)

Default = 1

Function:

Adjusts the PWM modulation index to maximize output power for applications with a nominal VP voltage of less than or equal to 14 V. This bit must remain set for applications with a nominal VP voltage greater than 14 V.

SelectVP Setting	Selected VP Level
0	VP ≤ 14 Volts
1	VP > 14 Volts.

9.5.2 Enable Thermal Foldback (EnTherm)

Default = 0

Function:

Enables the thermal foldback feature. See [“Thermal Foldback” on page 40](#) for more information.

EnTherm Setting	Thermal Foldback State
0	Disabled.
1	Enabled.

9.5.3 Lock Foldback Adjust (LockAdj)

Default = 0

Function:

Controls the operation of the foldback lock adjustment feature. See [“Thermal Foldback” on page 40](#) for more information.

LockAdj Setting	Foldback Adjustment Lock State
0	Attenuation lock disabled.
1	Attenuation lock enabled.

9.5.4 Foldback Attack Delay (*AttackDly[1:0]*)

Default = 01

Function:

Controls the foldback attack delay. See [“Thermal Foldback” on page 40](#) for more information.

AttackDly[1:0] Setting	Foldback Attack Time
00	Approximately 0.5 seconds.
01	Approximately 1.0 seconds.
10	Approximately 1.5 seconds.
11	Approximately 2.0 seconds.

9.5.5 Enable Foldback Floor (*EnFloor*)

Default = 0

Function:

Controls the foldback attenuation floor feature. See [“Thermal Foldback” on page 40](#) for more information.

EnFloor Setting	Attenuation Floor
0	No foldback attenuation floor imposed.
1	Maximum foldback attenuation limited to -30 dB.

9.5.6 Ramp Speed (*RmpSpd[1:0]*)

Default = 11

Function:

Controls the PWM output ramp speed. See [“PWM Popguard Transient Control” on page 45](#) for more information.

RmpSpd[1:0] Setting	Ramp Speed
00	Fastest Ramp Speed
10	Slowest Ramp Speed
11	Immediate. PWM Popguard Disabled.

9.6 Mixer / Pre-Scale Configuration (Address 06h)

7	6	5	4	3	2	1	0
PreScale2	PreScale1	PreScale0	Reserved	RChMix1	RChMix0	LChMix1	LChMix0

9.6.1 Pre-Scale Attenuation (*PreScale[2:0]*)

Default = 000

Function:

Controls the pre-scale attenuation level. See [“Pre-Scaler” on page 30](#) for more information.

PreScale[2:0] Setting	Pre-Scale Attenuation Setting
000	No pre-scale attenuation applied.
001	-2.0 dB
010	-4.0 dB
.....	
100	-8.0 dB
.....	
111	-14.0 dB

9.6.2 Right Channel Mixer (RChMix[1:0])

Default = 00

Function:

Controls the right channel mixer output. See [“Channel Mixer” on page 30](#) for more information.

RChMix[1:0] Setting	Right Channel Mixer Output on Channel B
00	Right Channel
01	(Left Channel + Right Channel) / 2
10	(Left Channel + Right Channel) / 2
11	Left Channel

9.6.3 Left Channel Mixer (LChMix[1:0])

Default = 00

Function:

Controls the left channel mixer output. See [“Channel Mixer” on page 30](#) for more information.

LChMix[1:0] Setting	Left Channel Mixer Output on Channel A
00	Left Channel
01	(Left Channel + Right Channel) / 2
10	(Left Channel + Right Channel) / 2
11	Right Channel

9.7 Tone Configuration (Address 07h)

7	6	5	4	3	2	1	0
DeEmph	Loudness	EnDigHPF	TrebFc1	TrebFc0	BassFc1	BassFc0	EnToneCtrl

9.7.1 De-Emphasis Control (DeEmph)

Default = 0

Function:

Controls the operation of the internal de-emphasis filter. See [“De-Emphasis” on page 31](#) for more information.

DeEmph Setting	De-Emphasis State
0	No de-emphasis applied.
1	44.1 kHz 50/15 μ s de-emphasis filter applied.

9.7.2 Adaptive Loudness Compensation Control (Loudness)

Default = 0

Function:

Controls the operation of the adaptive loudness compensation feature. See [“Adaptive Loudness Compensation” on page 34](#) for more information.

Loudness Setting	Adaptive Loudness Compensation State
0	Disabled.
1	Enabled.

9.7.3 Digital Signal Processing High-Pass Filter (*EnDigHPF*)

Default = 0

Function:

Controls the operation of the digital signal processing high-pass filter. See [“Digital Signal Processing High-Pass Filter” on page 30](#) for more information.

EnDigHPF Setting	Digital Signal Processing High-Pass Filter State
0	Digital signal processing high-pass filter disabled.
1	Digital signal processing high-pass filter enabled.

9.7.4 Treble Corner Frequency (*TrebFc[1:0]*)

Default = 00

Function:

Sets the corner frequency for the treble shelving filter as shown below.

TrebFc[1:0] Setting	Treble Corner Frequency
00	Selects Treble Fc 0 - Approximately 5 kHz
01	Selects Treble Fc 1 - Approximately 7 kHz
10	Selects Treble Fc 2 - Approximately 10 kHz
11	Selects Treble Fc 3 - Approximately 15 kHz

9.7.5 Bass Corner Frequency (*BassFc[1:0]*)

Default = 01

Function:

Sets the corner frequency for the bass shelving filter as shown below.

BassFc[1:0] Setting	Bass Corner Frequency
00	Selects Bass Fc 0 - Approximately 50 Hz
01	Selects Bass Fc 1 - Approximately 100 Hz
10	Selects Bass Fc 2 - Approximately 200 Hz
11	Selects Bass Fc 3 - Approximately 250 Hz

9.7.6 Tone Control Enable (*EnToneCtrl*)

Default = 0

Function:

When set, enables the bass and treble shelving filters. When cleared, disables the bass and treble shelving filters.

EnToneCtrl Setting	Tone Control Filter State
0	Bass and treble shelving filters disabled.
1	Bass and treble shelving filters enabled.

9.8 Tone Control (Address 08h)

7	6	5	4	3	2	1	0
Treble3	Treble2	Treble1	Treble0	Bass3	Bass2	Bass1	Bass0

9.8.1 Treble Gain Level (Treb[3:0])

Default = 1000

Function:

Sets the gain/attenuation level of the treble shelving filter. The level can be adjusted in 1.5 dB steps from +12.0 to -10.5 dB.

Treb[3:0] Setting	Treble Shelving Filter Gain/Attenuation
0000	+12 dB
0001	+10.5 dB
.....	
1000	0 dB
.....	
1110	-9.0 dB
1111	-10.5 dB

9.8.2 Bass Gain Level (Bass[3:0])

Default = 1000

Function:

Sets the gain/attenuation level of the bass shelving filter. The level can be adjusted in 1.5 dB steps from +12.0 to -10.5 dB.

Bass[3:0] Setting	Bass Shelving Filter Gain/Attenuation
0000	+12 dB
0001	+10.5 dB
.....	
1000	0 dB
.....	
1110	-9.0 dB
1111	-10.5 dB

9.9 2.1 Bass Manager/Parametric EQ Control (Address 09h)

7	6	5	4	3	2	1	0
Freeze	HiZPSig	BassMgr2	BassMgr1	BassMgr0	Reserved	EnChBPEq	EnChAPEq

9.9.1 Freeze Controls (Freeze)

Default = 0

Function:

This function will freeze the previous output of, and allow modifications to be made to the master volume control (address 57h), channel X volume control (address 58h - 5Ah), and bi-quad coefficient registers for channel A, and channel B (address 0Ah - 54h) without the changes taking effect until the Freeze bit is disabled. To make multiple changes in these control port registers take effect simultaneously, enable the Freeze bit, make all register changes, then disable the Freeze bit.

Freeze Setting	Register Freeze State
0	Register freeze disabled.
1	Register freeze enabled.

9.9.2 **Hi-Z PWM_SIG Outputs (HiZPSig)**

Default = 0

Function:

When cleared, the PWM_SIG1 and PWM_SIG2 output drivers are placed in a high-impedance state. When set, the PWM_SIG1 and PWM_SIG2 output drivers are active. It should be noted that the function of the PWM_SIG outputs is determined by the PWMDSel[1:0] bits in Register 04h.

HiZPSig Setting	PWM_SIG Output Driver State
0	High impedance.
1	Drivers active.

9.9.3 **Bass Cross-Over Frequency (BassMgr[2:0])**

Default = 000

Function:

Controls the operation and cross-over frequency of the bass manager. See [“Bass Management” on page 35](#) for more information.

BassMgr[2:0] Setting	Bass Manager Crossover Setting
000	Bass manager disabled.
001	Selects Bass Manager Frequency 1 - Approximately 80 Hz
010	Selects Bass Manager Frequency 2 - Approximately 120 Hz
011	Selects Bass Manager Frequency 3 - Approximately 160 Hz
100	Selects Bass Manager Frequency 4 - Approximately 200 Hz
101	Selects Bass Manager Frequency 5 - Approximately 240 Hz
110	Selects Bass Manager Frequency 6 - Approximately 280 Hz
111	Selects Bass Manager Frequency 7 - Approximately 320 Hz

9.9.4 **Enable Channel B Parametric EQ (EnChBPEq)**

Default = 0

Function:

Enables the parametric EQ bi-quad filters for channel B.

EnChBPEq Setting	Channel B Parametric EQ State
0	Disabled.
1	Enabled.

9.9.5 **Enable Channel A Parametric EQ (EnChAPEq)**

Default = 0

Function:

Enables the parametric EQ bi-quad filters for channel A.

EnChAPEq Setting	Channel A Parametric EQ State
0	Disabled.
1	Enabled.

9.10 Volume and 2-Way Cross-Over Configuration (Address 55h)

7	6	5	4	3	2	1	0
SZCMode1	SZCMode0	Mute50/50	AutoMute	En2Way	2WayFreq2	2WayFreq1	2WayFreq0

9.10.1 Soft Ramp and Zero Cross Control (SZCMode[1:0])

Default = 10

Function:

Sets the soft ramp and zero crossing detection modes by which volume and muting changes will be implemented.

SZCMode[1:0] Setting	Soft Ramp & Zero Crossing Mode
00	Immediate Change When immediate change is selected, all level changes will take effect immediately in one step.
01	Zero Cross Zero cross dictates that signal level changes, both muting and attenuation, will occur on a signal zero crossing to minimize audible artifacts. The requested level change will occur after a timeout period (approximately 18.7 ms for a PWM switch rate of 384/768 kHz and 17.0 ms for a PWM switch rate of 421.875/843.75 kHz) if the signal does not encounter a zero crossing. The zero cross function is independently monitored and implemented for each channel.
10	Soft Ramp Soft ramp allows level changes, both muting and attenuation, to be implemented by incrementally ramping, in ½ dB steps, from the current level to the new level at a rate of ½ dB per 4 sample periods for 32, 44.1, and 48 kHz, and ½ dB per 8 sample periods for 96 kHz.
11	Soft Ramp on Zero Cross Soft ramp on zero cross dictates that signal level changes, both muting and attenuation, will occur in ½ dB steps and be implemented on a signal zero crossing. The ½ dB level change will occur after a timeout period (approximately 18.7 ms for a PWM switch rate of 384/768 kHz and 17.0 ms for a PWM switch rate of 421.875/843.75 kHz) if the signal does not encounter a zero crossing. The zero cross function is independently monitored and implemented for each channel.

9.10.2 Enable 50% Duty Cycle for Mute Condition (Mute50/50)

Default = 0

Function:

When set, the amplifiers will output a non-modulated 50%-duty-cycle signal for all mute conditions. This bit does not cause a mute condition to occur. The Mute50/50 bit only defines operation during a normal mute condition.

Mute50/50 Setting	50% Duty Cycle Mute State
0	50% duty cycle for mute conditions disabled.
1	50% duty cycle for mute conditions enabled.

9.10.3 Auto-Mute (AutoMute)

Default = 1

Function:

When enabled, the outputs of the CS4525 will mute following the reception of 8192 consecutive audio samples of static 0 or -1. A single sample of non-static data will release the mute. Detection and muting is done independently for each channel. See [“Volume and Muting Control” on page 36](#) for more information.

AutoMute Setting	AutoMute State
0	Auto-mute on static 0's or -1's disabled.
1	Auto-mute on static 0's or -1's enabled.

9.10.4 Enable 2-Way Crossover (En2Way)

Default = 0

Function:

Enables the 2-way crossover filters for channel 1 and channel 2.

En2Way Setting	2-Way Crossover State
0	2-way crossover disabled.
1	2-way crossover enabled.

9.10.5 2-Way Cross-Over Frequency (2WayFreq[2:0])

Default = 000

Function:

Selects the cross-over frequency for the 2-Way Linkwitz-Riley filters.

2WayFreq Setting	2-Way Crossover Frequency
000	Selects X-Over Freq 0 - Approximately 2.0 kHz
001	Selects X-Over Freq 1 - Approximately 2.2 kHz
010	Selects X-Over Freq 2 - Approximately 2.4 kHz
011	Selects X-Over Freq 3 - Approximately 2.6 kHz
100	Selects X-Over Freq 4 - Approximately 2.8 kHz
101	Selects X-Over Freq 5 - Approximately 3.0 kHz
110	Selects X-Over Freq 6 - Approximately 3.2 kHz
111	Selects X-Over Freq 7 - Approximately 3.4 kHz

9.11 Channel A & B: 2-Way Sensitivity Control (Address 56h)

7	6	5	4	3	2	1	0
LowPass3	LowPass2	LowPass1	LowPass0	HighPass3	HighPass2	HighPass1	HighPass0

9.11.1 Channel A and Channel B Low-Pass Sensitivity Adjust (LowPass[3:0])

Default = 0000

Function:

Controls the 2-way cross-over low-pass sensitivity adjustment. See ["2-Way Crossover & Sensitivity Control" on page 41](#) for more information.

LowPass[3:0] Setting	Sensitivity Compensation Level
0000	0.0 dB
0001	-0.5 dB
0010	-1.0 dB
.....
1000	-4.0 dB
.....
1110	-7.0 dB
1111	-7.5 dB

9.11.2 Channel A and Channel B High-Pass Sensitivity Adjust (HighPass[3:0])

Default = 0000

Function:

Controls the 2-way cross-over high-pass sensitivity adjustment. See [“2-Way Crossover & Sensitivity Control” on page 41](#) for more information.

HighPass[3:0] Setting	Sensitivity Compensation Level
0000	0.0 dB
0001	-0.5 dB
0010	-1.0 dB
.....	
1000	-4.0 dB
.....	
1110	-7.0 dB
1111	-7.5 dB

9.12 Master Volume Control (Address 57h)

7	6	5	4	3	2	1	0
MVol7	MVol6	MVol5	MVol4	MVol3	MVol2	MVol1	MVol0

9.12.1 Master Volume Control (MVol[7:0])

Default = 2Ah

Function:

Sets the gain/attenuation level of the master volume control. See [“Volume and Muting Control” on page 36](#) for more information.

MVol[7:0] Setting	Master Volume Setting
0000 0000	+24 dB
.....	
0010 1010	+3 dB
.....	
0011 0000	0.0 dB
0011 0001	-0.5 dB
0011 0010	-1.0 dB
.....	
1111 1110	-103.0 dB
1111 1111	Master Mute

9.13 Channel A and B Volume Control (Address 58h & 59h)

7	6	5	4	3	2	1	0
ChXVol7	ChXVol6	ChXVol5	ChXVol4	ChXVol3	ChXVol2	ChXVol1	ChXVol0

9.13.1 Channel X Volume Control (ChXVol[7:0])

Default = 30h

Function:

Sets the gain/attenuation levels of channel A and channel B. See [“Volume and Muting Control” on page 36](#) for more information.

ChXVol[7:0] Setting	Channel X Volume Setting
0000 0000	+24 dB
0011 0000	0.0 dB
0011 0001	-0.5 dB
0011 0010	-1.0 dB
1111 1110	-103.0 dB
1111 1111	Channel Mute

9.14 Sub Channel Volume Control (Address 5Ah)

7	6	5	4	3	2	1	0
SubVol7	SubVol6	SubVol5	SubVol4	SubVol3	SubVol2	SubVol1	SubVol0

9.14.1 Sub Channel Volume Control (SubVol[7:0])

Default = 30h

Function:

Sets the gain/attenuation levels of the sub channel. See [“Volume and Muting Control” on page 36](#) for more information.

SubVol[7:0] Setting	Sub Channel Volume Setting
0000 0000	+24 dB
0011 0000	0.0 dB
0011 0001	-0.5 dB
0011 0010	-1.0 dB
1111 1110	-103.0 dB
1111 1111	Channel Mute

9.15 Mute/Invert Control (Address 5Bh)

7	6	5	4	3	2	1	0
InvADC	InvSub	InvCh2	InvCh1	MuteADC	MuteSub	MuteChB	MuteChA

9.15.1 ADC Invert Signal Polarity (InvADC)

Default = 0

Function:

When set, the signal polarity of the ADC will be inverted.

InvADC Setting	ADC Signal Inversion State
0	ADC signal polarity not inverted.
1	ADC signal polarity inverted.

9.15.2 Invert Channel PWM Signal Polarity (InvChX)

Default = 0

Function:

When set, the respective channel's power and logic-level PWM output signal polarity will be inverted. The serial output on the auxiliary and delay ports are unaffected.

InvChX Setting	Channel X PWM Signal Inversion State
0	Channel X PWM signal polarity not inverted.
1	Channel X PWM signal polarity inverted.

9.15.3 Invert Sub PWM Signal Polarity (InvSub)

Default = 0

Function:

When set, the Sub channel's power and logic-level PWM output polarity will be inverted. The serial output on the auxiliary port is unaffected.

InvSub Setting	Sub Channel PWM Signal Inversion State
0	Sub channel PWM signal polarity not inverted.
1	Sub channel PWM signal polarity inverted.

9.15.4 ADC Channel Mute (MuteADC)

Default = 0

Function:

The output of the ADC will mute when enabled.

MuteADC Setting	ADC Mute State
0	ADC un-muted.
1	ADC muted.

9.15.5 Independent Channel A & B Mute (MuteChX)

Default = 0

Function:

The respective channel's power PWM, logic-level PWM, and auxiliary serial data outputs will enter a mute state when enabled. The delay serial output will be unaffected if the delay port is enabled. The muting

function is affected, similar to attenuation changes, by the soft and zero cross bits (SZCMode[1:0]). See [“Volume and Muting Control” on page 36](#) for more information.

MuteChX Setting	Channel X PWM Mute State
0	Channel X PWM outputs un-muted.
1	Channel X PWM outputs muted.

9.15.6 Sub Channel Mute (MuteSub)

Default = 0

Function:

The sub channel's power PWM, logic-level PWM, and auxiliary serial data outputs will enter a mute state when enabled. The muting function is affected, similar to attenuation changes, by the soft and zero cross bits (SZCMode[1:0]). See [“Volume and Muting Control” on page 36](#) for more information.

MuteSub Setting	Sub Channel PWM Mute State
0	Sub channel PWM outputs un-muted.
1	Sub channel PWM outputs muted.

9.16 Limiter Configuration 1 (Address 5Ch)

7	6	5	4	3	2	1	0
Max2	Max1	Max0	Min2	Min1	Min0	LimitAll	EnLimiter

9.16.1 Maximum Threshold (Max[2:0])

Default = 000

Function:

Sets the maximum level, below full scale, at which to limit and attenuate the output signal at the limiter attack rate.

Max[2:0] Setting	Maximum Threshold Setting
000	0.0 dB
001	-3.0 dB
010	-6.0 dB
011	-9.0 dB
100	-12.0 dB
101	-18.0 dB
110	-24.0 dB
111	-30.0 dB

9.16.2 Minimum Threshold (Min[2:0])

Default = 000

Function:

Sets a minimum level below full scale at which the limiter will begin to release its applied attenuation.

Min[2:0] Setting	Minimum Threshold Setting
000	0.0 dB
001	-3.0 dB
010	-6.0 dB
011	-9.0 dB
100	-12.0 dB
101	-18.0 dB
110	-24.0 dB
111	-30.0 dB

9.16.3 Peak Signal Limit All Channels (LimitAll)

Default = 1

Function:

When cleared, the peak signal limiter will limit the maximum signal amplitude to prevent clipping on the specific channel indicating clipping. The other channels will not be affected. When set, the peak signal limiter will limit the maximum signal amplitude to prevent clipping on all channels in response to any single channel indicating clipping. See [“Peak Signal Limiter” on page 37](#) for more information.

LimitAll Setting	Limit All Channels Configuration
0	Only individual channels affected by any limiter event.
1	All channels affected by any limiter event.

9.16.4 Peak Detect and Limiter Enable (EnLimiter)

Default = 0

Function:

Limits the maximum signal amplitude to prevent clipping when this function is enabled. Peak signal limiting is performed by digital attenuation.

EnLimiter Setting	Peak Signal Limiter State
0	Peak signal limiter disabled.
1	Peak signal limiter enabled.

9.17 Limiter Configuration 2 (Address 5Dh)

7	6	5	4	3	2	1	0
Reserved	Reserved	RRate5	RRate4	RRate3	RRate2	RRate1	RRate0

9.17.1 Limiter Release Rate (RRate[5:0])

Default = 111111

Function:

Sets the rate at which the limiter releases the digital attenuation from levels below the minimum setting in the limiter threshold register.

The limiter release rate is a function of the sampling frequency, F_s , and the soft and zero cross setting.

RRate[5:0] Setting	Limiter Release Rate
000000	Fastest release.
.....	
111111	Slowest release.

9.18 Limiter Configuration 3 (Address 5Eh)

7	6	5	4	3	2	1	0
EnThLim	Reserved	ARate5	ARate4	ARate3	ARate2	ARate1	ARate0

9.18.1 Enable Thermal Limiter (EnThLim)

Default = 0

Function:

When set, enables the thermal limiter function. The thermal limiter function adds an additional -3dB of attenuation to the min and max settings of the peak signal limiter the first time a thermal warning is detected after the thermal limiter function has been enabled. For more details, see the [“Thermal Limiter” section on page 39](#).

EnThLim Setting	Thermal Limiter State
0	Thermal limiter disabled.
1	Thermal limiter enabled.

9.18.2 Limiter Attack Rate (ARate[5:0])

Default = 000000

Function:

Sets the rate at which the limiter attenuates the analog output from levels above the maximum setting in the limiter threshold register. The limiter attack rate is a function of the sampling frequency, F_s , and the soft and zero cross setting.

ARate[5:0] Setting	Limiter Attack Rate
000000	Fastest attack.
.....	
111111	Slowest attack.

9.19 Power Control (Address 5Fh)

7	6	5	4	3	2	1	0
AutoRetry	EnOCProt	SelectVD	PDnADC	PDnOut3/4	PDnOut2	PDnOut1	PDnAll

9.19.1 Automatic Power Stage Retry (AutoRetry)

Default = 1

Function:

Enables the Auto-Retry function upon over-current error. See [“Automatic Power Stage Shut-Down” on page 53](#).

AutoRetry Setting	Auto-Retry State
0	Auto-Retry feature disabled.
1	Auto-Retry feature enabled.

9.19.2 Enable Over-Current Protection (EnOCProt)

Default = 1

Function:

Enables the PWM power output over-current protection feature described in [“Automatic Power Stage Shut-Down” on page 53](#).

WARNING: The EnOCProt bit must never be changed from its default value of 1. Doing so will disable the over-current protection feature and may result in permanent damage to the CS4525.

9.19.3 Select VD Level (SelectVD)

Default = 1

Function:

This bit selects between a VD of 2.5 V, 3.3 V, or 5.0 V.

SelectVD Setting	Selected VD Level
0	VD = 2.5 V.
1	VD = 3.3 V or 5.0 V.

9.19.4 Power Down ADC (PDnADC)

Default = 1

Function:

The ADC will enter a power down state when this bit is enabled.

PDnADC Setting	ADC Power-Down State
0	Normal ADC operation.
1	ADC power-down enabled.

9.19.5 Power Down PWM Power Output X (PDnOutX)

Default = 1

Function:

When set, the specific PWM power output will enter a power-down state. Only the output power stage is powered down. The PWM modulator is not affected, nor are the setup or delay register values. When set to normal operation, the specific output will power up according to the state of the RmpSpd[1:0] bits and

the channel output configuration selected. When transitioning from normal operation to power down, the specific output will power down according to the state of the RmpSpd[1:0] bits and the channel output configuration selected.

PDnChX Setting	Power Output X Power-Down State
0	Normal power output X operation.
1	Power output X power-down enabled.

The entire divide will enter a low-power state when this function is enabled:

9.19.6 Power Down (PDnAll)

Default = 1

Function:

The CS4525 will enter a power-down state when this function is enabled:

1. The power PWM outputs will be held in a high-impedance state.
2. The logic-level PWM outputs will continuously drive a logic '0' if the $\overline{\text{HiZPSig}}$ bit is set and will be held in a high-impedance state if the $\overline{\text{HiZPSig}}$ bit is clear.
3. AUX_SDOU, the auxiliary serial data output, will be driven to a digital-low. AUX_LRCK and AUX_SCLK, the auxiliary serial output's clocks, will continue to operate if the EnAuxPort bit is set, ADC/SP is cleared, and the serial audio input receives a valid SCLK and LRCK; otherwise they will also be driven to a digital-low voltage.
4. DLY_SDOU, the delay serial data output, will output the unprocessed audio data from SDATA if EnAuxPort is set, DlyPortCfg[1:0] is configured for serial output delay interface, ADC/SP is cleared, and the serial audio input port receives a valid SCLK, LRCK, and SDATA. Otherwise, it will drive a low voltage.

The contents of the control registers are retained in this state. Once the PDnAll bit is disabled, the powered and logic-level PWM outputs will first perform a click-free start-up function and then resume normal operation.

The PDnAll bit defaults to 'enabled' on power-up and must be disabled before normal operation can occur.

PDnAll Setting	Device Power-Down State
0	Normal device operation.
1	Device power-down enabled.

9.20 Interrupt (Address 60h)

7	6	5	4	3	2	1	0
SRCLock	ADCOvfl	ChOvfl	AmpErr	SRCStateM	ADCOvflM	ChOvflM	AmpErrM

Bits [7:4] in this register are read only. A '1'b in these bit positions indicates that the associated condition has occurred at least once since the register was last read. A '0'b indicates that the associated condition has not occurred since the last reading of the register. Reading the register resets bits to [7:4] '0'b. These bits are considered "edge-triggered" events. The operation of these 4 bits is not affected by the interrupt mask bits and the condition of each bit can be polled instead of generating an interrupt as required.

9.20.1 SRC Lock State Transition Interrupt (SRCLock)

Function:

This bit is read only. When set, indicates that the SRC has transitioned from an unlock to lock state or from a lock state to an unlock state since the last read of this register. Conditions which cause the SRC to transition states, such as loss of LRCK, SCLK, an LRCK ratio change, or the SRC achieving lock, will

cause this bit to be set. This interrupt bit is an edge-triggered event and will be cleared following a read of this register.

If this bit is set, indicating a SRC state change condition, and the SRClockM bit is set, the INT pin will go active. To determine the current lock state of the SRC, read the SRClockSt bit in the interrupt status register.

SRCLock Setting	SRC Lock State Change Status
0	SRC lock state unchanged since last read of this register.
1	SRC lock state changed since last read of this register.

9.20.2 ADC Overflow Interrupt (ADCOvfl)

Function:

This bit is read only. When set, indicates that an over-range condition occurred anywhere in the CS4525 ADC signal path and has been clipped to positive or negative full scale as appropriate since the last read of this register. This interrupt bit is an edge-triggered event and will be cleared following a read of this register.

If this bit is set, indicating an ADC over-range condition, and the ADCovfIM bit is set, the INT pin will go active. To determine the current overflow state of the ADC, read the ADCovflSt bit in the interrupt status register.

ADCOvfl Setting	ADC Overflow Event Status
0	ADC overflow condition has not occurred since last read of this register.
1	ADC overflow condition has occurred since last read of this register.

9.20.3 Channel Overflow Interrupt (ChOvfl)

Function:

This bit is read only. When set, indicates that the magnitude of an output sample on channel 1, 2, or the Sub channel has exceeded full scale and has been clipped to positive or negative full scale as appropriate since the last read of this register. This interrupt bit is an edge-triggered event and will be cleared following a read of this register.

If this bit is set, indicating a channel over-range condition, and the ChOvfIM bit is set, the INT pin will go active. To determine the current overflow state of each channel, read the ChXOvflSt and SubOvflSt bits in the interrupt status register.

ChOvfl Setting	Channel Overflow Event Status
0	A channel overflow condition has not occurred since last read of this register.
1	A channel overflow condition has occurred since last read of this register.

9.20.4 Amplifier Error Interrupt Bit (AmpErr)

Function:

This bit is read only. When set, indicates that an error was detected in the power amplifier section since the last read of this register. This interrupt bit is an edge-triggered event and will be cleared following a read of this register. This bit is the logical OR of all the bits in the amplifier error status register. Read the amplifier error status register to determine which condition occurred.

If this bit is set, indicating an amplifier stage error condition, and the AmpErrM bit is set to a '1'b, the INT pin will go active. To determine the actual current state of the amplifier error condition, read the amplifier error status register.

AmpErr Setting	Amplifier Error Event Status
0	An amplifier error condition has not occurred since last read of this register.
1	An amplifier error condition has occurred since last read of this register.

9.20.5 Mask for SRC State (SRCLockM)

Default = 0

Function:

This bit serves as a mask for the SRC status interrupt source. If this bit is set, the SRCLock interrupt is unmasked, meaning that if the SRCLock bit is set, the INT pin will go active. If the SRCLockM bit is cleared, the SRCLock condition is masked, meaning that its occurrence will not affect the INT pin. However, the SRCLock and SRCLockSt bits will continue to reflect the lock status of the SRC.

SRCLockM Setting	SRCLock INT Pin Mask State
0	SRCLock condition masked.
1	SRCLock condition un-masked.

9.20.6 Mask for ADC Overflow (ADCOvfIM)

Default = 0

Function:

This bit serves as a mask for the ADC overflow interrupt source. If this bit is set, the ADCOvfl interrupt is unmasked, meaning that if the ADCOvfl bit is set, the INT pin will go active. If the ADCOvfIM bit is cleared, the ADCOvfl condition is masked, meaning that its occurrence will not affect the INT pin. However, the ADCOvfl and ADCOvflSt bits will continue to reflect the overflow state of the ADC.

ADCOvfIM Setting	ADCOvfl INT Pin Mask State
0	ADCOvfl condition masked.
1	ADCOvfl condition un-masked.

9.20.7 Mask for Channel X and Sub Overflow (ChOvfIM)

Default = 0

Function:

This bit serves as a mask for the channel 1, 2, and Sub overflow interrupt source. If this bit is set, the ChOvfl interrupt is unmasked, meaning that if the ChOvfl bit is set, the INT pin will go active. If the ChOvfIM bit is cleared, the ChOvfl condition is masked, meaning that its occurrence will not affect the INT pin. However, the ChOvfl, ChXOvfIM, and SubOvfIM bits will continue to reflect the overflow state of the individual channels.

ChOvfIM Setting	ChOvfl INT Pin Mask State
0	ChOvfl condition masked.
1	ChOvfl condition un-masked.

9.20.8 Mask for Amplifier Error (AmpErrM)

Default = 0

Function:

This bit serves as a mask for the amplifier error interrupt sources. If this bit is set, the AmpErr interrupt is unmasked, meaning that if the AmpErr bit is set, the INT pin will go active. If the AmpErrM bit is cleared, the AmpErr condition is masked, meaning that its occurrence will not affect the INT pin. However, the AmpErr and the amplifier error bits in the amplifier error status register will continue to reflect the status of the amplifier error conditions.

AmpErrM Setting	AmpErr INT Pin Mask State
0	AmpErr condition masked.
1	AmpErr condition un-masked.

9.21 Interrupt Status (Address 61h) - Read Only

7	6	5	4	3	2	1	0
SRCLockSt	ADCOvfSt	SubOvfSt	Ch2OvfSt	Ch1OvfSt	RampDone	Reserved	Reserved

All bits in this register are considered “level-triggered” events, meaning as long as a condition continues, the corresponding bit will remain set. These status bits are not affected by the interrupt mask bit and the condition of each bit can be polled. These bits will not be cleared following a read to this register, nor can they be written to cause an interrupt condition.

9.21.1 SRC State Transition (SRCLockSt)

Function:

This bit is read only and reflects the current lock state of the SRC. When set, indicates the SRC is currently locked. When cleared, indicates the SRC is currently unlocked.

SRCLockSt Setting	SRC Lock State
0	SRC is currently unlocked.
1	SRC is currently locked.

9.21.2 ADC Overflow (ADCOvfSt)

Function:

This bit is read only and will identify the presence of an overflow condition within the ADC. When set, indicates that an over-range condition is currently occurring in the CS4525 ADC signal path and has been clipped to positive or negative full scale.

ADCOvfSt Setting	ADC Overflow State
0	An ADC overflow condition is not currently present.
1	An ADC overflow condition is currently present.

9.21.3 Sub Overflow (SubOvfSt)

Function:

This bit is read only and will identify the presence of an overflow condition anywhere in the Sub channel's signal path. When set, indicates that an over-range condition is currently occurring in the Sub channel's signal path and has been clipped to positive or negative full scale.

SubOvfSt Setting	Sub Overflow State
0	An overflow condition is not currently present on the Sub channel.
1	An overflow condition is currently present on the Sub channel.

9.21.4 Channel X Overflow (ChXOvfSt)

Function:

These bits are read only and will identify the presence of an overflow condition anywhere in the associated channel's signal path. When set, indicates that an over-range condition is currently occurring in the channel's signal path and has been clipped to positive or negative full scale.

ChXOvfSt Setting	Channel X Overflow State
0	An overflow condition is not currently present on channel X.
1	An overflow condition is currently present on channel X.

9.21.5 Ramp-Up Cycle Complete (RampDone)

Function:

When set, indicates that all active channels have completed the configured ramp-up interval.

RampDone Setting	Ramp Completion State
0	Ramp-up interval not completed on all channels.
1	Ramp-up interval completed on all channels.

9.22 Amplifier Error Status (Address 62h) - Read Only

7	6	5	4	3	2	1	0
OverCurr4	OverCurr3	OverCurr2	OverCurr1	ExtAmpErr	Reserved	UVTE1	UVTE0

All bits in this register are considered "level-triggered" events, meaning as long as a condition continues, the corresponding bit will remain set. These status bits are not affected by the interrupt mask bit and the condition of each bit can be polled. These bits will not be cleared following a read to this register, nor can they be written to cause an interrupt condition.

9.22.1 Over-Current Detected On Channel X (OverCurrX)

Function:

When set, indicates an over current condition is currently present on the corresponding amplifier output.

OverCurrX Setting	Amplifier Over-Current Status
0	An over current condition is not currently present on amplifier output X.
1	An over current condition is currently present on amplifier output X.

9.22.2 External Amplifier State (ExtAmpSt)

Function:

When set, indicates a thermal warning condition is currently being reported by an external amplifier. For proper operation, the delay serial port must be configured to support an external thermal warning input signal. This status bit reflects the active state of the external thermal warning input signal.

ExtAmpSt Setting	External Amplifier Status
0	A thermal warning condition is not currently being reported by an external amplifier.
1	A thermal warning condition is currently being reported by an external amplifier.

9.22.3 Under Voltage / Thermal Error State (UVTE[1:0])

Function:

Indicates the operational status of the amplifier. These bits can identify a Thermal Warning condition, a Thermal Error condition, or an Under Voltage condition. The thresholds for each of these conditions is listed in the [PWM Power Output Characteristics](#) table on [page 20](#).

UVTE[1:0] Setting	Under Voltage & Thermal Error Status
00	The device is operating normally.
01	The device is operating normally; however a Thermal Warning condition is being reported.
10	An Under Voltage condition is currently present.
11	A Thermal Error condition is currently present.

9.23 Device I.D. and Revision (Address 63h) - Read Only

7	6	5	4	3	2	1	0
DeviceID4	DeviceID3	DeviceID2	DeviceID1	DeviceID0	RevID2	RevID1	RevID0

9.23.1 Device Identification (DeviceID[4:0])

Default = 11111

Function:

Identification code for the CS4525.

DeviceID[4:0] Setting	Device ID Notes
11111.....	Permanent device identification code.

9.23.2 Device Revision (RevID[2:0])

Function:

Identifies the CS4525 device revision.

RevID[2:0] Setting	Device Revision
000	Revision A0 and B0.
010	Revision C0.

10. PARAMETER DEFINITIONS

Dynamic Range (DYR)

The ratio of the rms value of the signal to the rms sum of all other spectral components over the specified bandwidth, typically 20 Hz to 20 kHz. Dynamic Range is a signal-to-noise ratio measurement over the specified band width made with a -60 dBFS signal. 60 dB is then added to the resulting measurement to refer the measurement to full-scale. This technique ensures that the distortion components are below the noise level and do not effect the measurement. This measurement technique has been accepted by the Audio Engineering Society, AES17-1991, and the Electronic Industries Association of Japan, EIAJ CP-307. Expressed in decibels.

Total Harmonic Distortion + Noise (THD+N)

The ratio of the rms value of the signal to the rms sum of all other spectral components over the specified band width (typically 10 Hz to 20 kHz), including distortion components. Expressed in decibels. Measured as suggested in AES17-1991 Annex A.

Frequency Response

FR is the deviation in signal level verses frequency. The 0 dB reference point is 1 kHz. The amplitude corner, Ac, lists the maximum deviation in amplitude above and below the 1 kHz reference point. The listed minimum and maximum frequencies are guaranteed to be within the Ac from minimum frequency to maximum frequency inclusive.

Interchannel Isolation

A measure of crosstalk between the left and right channels. Measured for each channel at the converter's output with no signal to the input under test and a full-scale signal applied to the other channel. Units in decibels.

Interchannel Gain Mismatch

The gain difference between left and right channels. Units in decibels.

Gain Drift

The change in gain value with temperature. Units in ppm/°C.

F_s

Sampling Frequency.

Resolution

The number of bits in a serial audio data word.

SRC

Sample Rate Converter. Converts data derived at one sample rate to a differing sample rate.

11. REFERENCES

1. Cirrus Logic, "AN18: Layout and Design Rules for Data Converters and Other Mixed Signal Devices," Version 6.0, February 1998.
2. Cirrus Logic, "AN22: Overview of Digital Audio Interface Data Structures, Version 2.0", February 1998.; A useful tutorial on digital audio specifications.
3. Philips Semiconductor, "The I²C-Bus Specification: Version 2," Dec. 1998.
<http://www.semiconductors.philips.com>

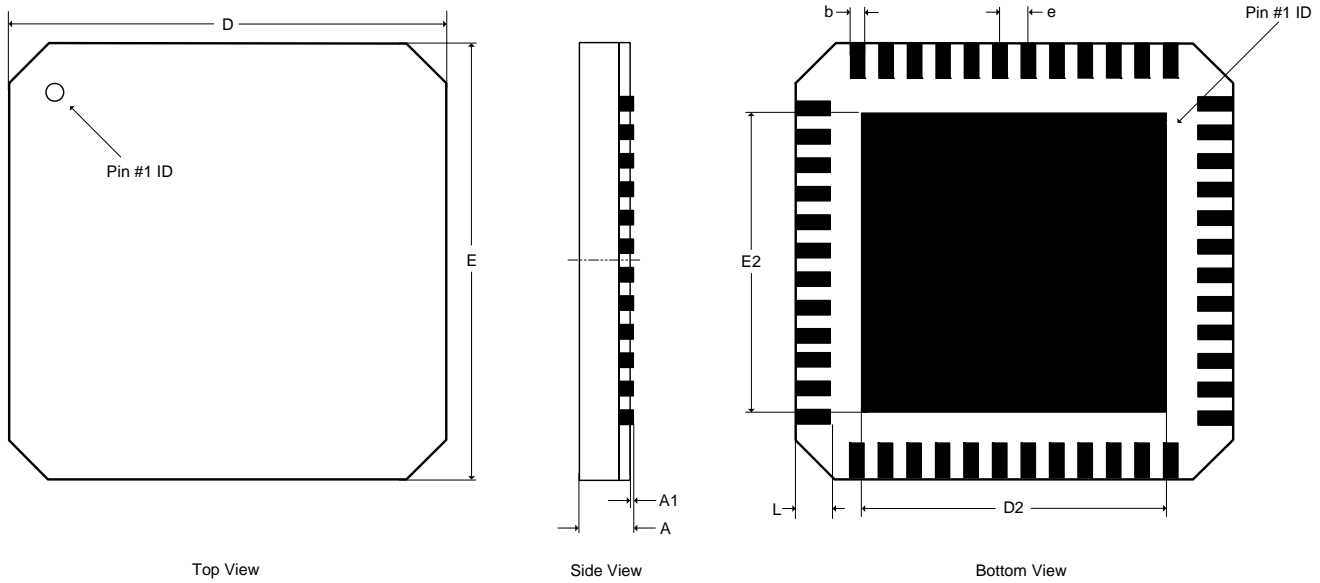
12.PACKAGE DIMENSIONS
48L QFN (9 × 9 MM BODY) PACKAGE DRAWING

DIM	INCHES			MILLIMETERS			NOTE
	MIN	NOM	MAX	MIN	NOM	MAX	
A	--	--	0.0354	--	--	0.90	1
A1	0.0000	--	0.0020	0.00	--	0.05	1
b	0.0118	0.0138	0.0157	0.30	0.35	0.40	1,2
D	0.3543 BSC			9.00 BSC			1
D2	0.2618	0.2677	0.2736	6.65	6.80	6.95	1
E	0.3543 BSC			9.00 BSC			1
E2	0.2618	0.2677	0.2736	6.65	6.80	6.95	1
e	0.0256 BSC			0.65 BSC			1
L	0.0177	0.0217	0.0276	0.45	0.55	0.70	1

JEDEC #: MO-220

Controlling Dimension is Millimeters.

Table 22:

- Notes:**
1. Dimensioning and tolerance per ASME Y4.5M - 1994.
 2. Dimensioning lead width applies to the plated terminal and is measured between 0.20 mm and 0.25 mm from the terminal tip.

13.THERMAL CHARACTERISTICS

Parameter	Symbol	Min	Typ	Max	Units
Junction to Case Thermal Impedance	θ_{JC}	-	1	-	°C/Watt

13.1 Thermal Flag

This device is designed to have the metal flag on the bottom of the device soldered directly to a metal plane on the PCB. To enhance the thermal dissipation capabilities of the system, this metal plane should be coupled with vias to a large metal plane on the backside (and inner ground layer, if applicable) of the PCB.

In either case, it is beneficial to use copper fill in any unused regions inside the PCB layout, especially those immediately surrounding the CS4525. In addition to improving in electrical performance, this practice also aids in heat dissipation.

The heat dissipation capability required of the metal plane for a given output power can be calculated as follows:

$$\theta_{CA} = [(T_{J(MAX)} - T_A) / P_D] - \theta_{JC}$$

where,

θ_{CA} = Thermal resistance of the metal plane in °C/Watt

$T_{J(MAX)}$ = Maximum rated operating junction temperature in °C, equal to 150 °C

T_A = Ambient temperature in °C

P_D = RMS power dissipation of the device, equal to $0.15 * P_{RMS}$ (assuming 85% efficiency)

θ_{JC} = Junction-to-case thermal resistance of the device in °C/Watt

14.ORDERING INFORMATION

Product	Description	Package	Pb-Free	Grade	Temp Range	Container	Order#
CS4525	Digital Audio Amp with Integrated ADC	48-QFN	Yes	Commercial	-10° to +70°C	Rail	CS4525-CNZ
						Tape and Reel	CS4525-CNZR
CRD4525-Q1	4 Layer / 1oz. Copper Reference Design Board	-	-	-	-	-	CRD4525-Q1
CRD4525-D1	2 Layer / 1oz. Copper Reference Design Board	-	-	-	-	-	CRD4525-D1

15. REVISION HISTORY

Release	Changes
PP1	The following items were updated: "Analog Input Characteristics" on page 19 "PWM Power Output Characteristics" on page 20 "XTI Switching Specifications" on page 23 "SYS_CLK Switching Specifications" on page 23 "Digital Interface Specifications" on page 25 Section 6.4.1 "Half-Bridge Output Filter" on page 59 Section 6.4.2 "Full-Bridge Output Filter (Stereo or Parallel)" on page 60 Table 21, "Power Supply Configuration and Settings," on page 63 Section 9.19.3 "Select VD Level (SelectVD)" on page 88
PP2	Added Section 9.19.2 "Enable Over-Current Protection (EnOCProt)" on page 88

Contacting Cirrus Logic Support

For all product questions and inquiries, contact a Cirrus Logic Sales Representative.
 To find one nearest you, go to www.cirrus.com.

IMPORTANT NOTICE

"Preliminary" product information describes products that are in production, but for which full characterization data is not yet available. Cirrus Logic, Inc. and its subsidiaries ("Cirrus") believe that the information contained in this document is accurate and reliable. However, the information is subject to change without notice and is provided "AS IS" without warranty of any kind (express or implied). Customers are advised to obtain the latest version of relevant information to verify, before placing orders, that information being relied on is current and complete. All products are sold subject to the terms and conditions of sale supplied at the time of order acknowledgment, including those pertaining to warranty, indemnification, and limitation of liability. No responsibility is assumed by Cirrus for the use of this information, including use of this information as the basis for manufacture or sale of any items, or for infringement of patents or other rights of third parties. This document is the property of Cirrus and by furnishing this information, Cirrus grants no license, express or implied under any patents, mask work rights, copyrights, trademarks, trade secrets or other intellectual property rights. Cirrus owns the copyrights associated with the information contained herein and gives consent for copies to be made of the information only for use within your organization with respect to Cirrus integrated circuits or other products of Cirrus. This consent does not extend to other copying such as copying for general distribution, advertising or promotional purposes, or for creating any work for resale.



CERTAIN APPLICATIONS USING SEMICONDUCTOR PRODUCTS MAY INVOLVE POTENTIAL RISKS OF DEATH, PERSONAL INJURY, OR SEVERE PROPERTY OR ENVIRONMENTAL DAMAGE ("CRITICAL APPLICATIONS"). CIRRUS PRODUCTS ARE NOT DESIGNED, AUTHORIZED OR WARRANTED FOR USE IN PRODUCTS SURGICALLY IMPLANTED INTO THE BODY, AUTOMOTIVE SAFETY OR SECURITY DEVICES, LIFE SUPPORT PRODUCTS OR OTHER CRITICAL APPLICATIONS. INCLUSION OF CIRRUS PRODUCTS IN SUCH APPLICATIONS IS UNDERSTOOD TO BE FULLY AT THE CUSTOMER'S RISK AND CIRRUS DISCLAIMS AND MAKES NO WARRANTY, EXPRESS, STATUTORY OR IMPLIED, INCLUDING THE IMPLIED WARRANTIES OF MERCHANTABILITY AND FITNESS FOR PARTICULAR PURPOSE, WITH REGARD TO ANY CIRRUS PRODUCT THAT IS USED IN SUCH A MANNER. IF THE CUSTOMER OR CUSTOMER'S CUSTOMER USES OR PERMITS THE USE OF CIRRUS PRODUCTS IN CRITICAL APPLICATIONS, CUSTOMER AGREES, BY SUCH USE, TO FULLY INDEMNIFY CIRRUS, ITS OFFICERS, DIRECTORS, EMPLOYEES, DISTRIBUTORS AND OTHER AGENTS FROM ANY AND ALL LIABILITY, INCLUDING ATTORNEYS' FEES AND COSTS, THAT MAY RESULT FROM OR ARISE IN CONNECTION WITH THESE USES.

Cirrus Logic, Cirrus, and the Cirrus Logic logo designs, and Popguard are trademarks of Cirrus Logic, Inc. All other brand and product names in this document may be trademarks or service marks of their respective owners.

l²C is a registered trademark of Philips Semiconductor.

Looking for pricing, stock, or lifecycle information?

Click below to explore more details on WIN SOURCE:

-  [View CRD4525-Q1 on WIN SOURCE](#)
-  [Cirrus Logic Inc. Information](#)

Optimize Your Supply Chain with WIN SOURCE Solutions

-  Global Sourcing Solution
-  Obsolete Management
-  Cost Control Management
-  Shortage Management
-  Alternative Solution
-  Excess Inventory Management