

16-bit, 100 kSps / 20 kSps A/D Converters

Features

- Monolithic CMOS A/D Converters
 - Inherent Sampling Architecture
 - 2-channel Input Multiplexer
 - Flexible Serial Output Port
- Ultra-low Distortion
 - S/(N+D): 92 dB
 - TDH: 0.001%
- Conversion Time
 - CS5101A: 8µs
 - CS5102A: 40 µs
- Linearity Error: ±0.001% FS
 - Guaranteed No Missing Codes
- Self-calibration Maintains Accuracy
 - Accurate Over Time & Temperature
- Low Power Consumption
 - CS5101A: 320 mW
 - CS5102A: 44 mW

Description

The CS5101A and CS5102A are 16-bit monolithic CMOS analog-to-digital converters (ADCs) capable of 100 kSps (5101A) and 20 kSps (5102A) throughput. The CS5102A's low power consumption of 44mW, coupled with a power-down mode, makes it particularly suitable for battery-powered operation.

On-chip self-calibration circuitry achieves nonlinearity of ±0.001% of FS and guarantees 16-bit, no missing codes over the entire specified temperature range. Superior linearity also leads to 92 dB S/(N+D) with harmonics below -100 dB. Offset and full-scale errors are minimized during the calibration cycle, eliminating the need for external trimming.

The CS5101A and CS5102A each consist of a 2-channel input multiplexer, DAC, conversion and calibration microcontroller, clock generator, comparator, and serial communications port. The inherent sampling architecture of the device eliminates the need for an external track-and-hold amplifier.

The converters' 16-bit data is output in serial form with either binary or two's complement coding. Three output timing modes are available for easy interfacing to microcontrollers and shift registers. Unipolar and bipolar input ranges are digitally selectable.

ORDERING INFORMATION

See "Ordering Information" on page 38.

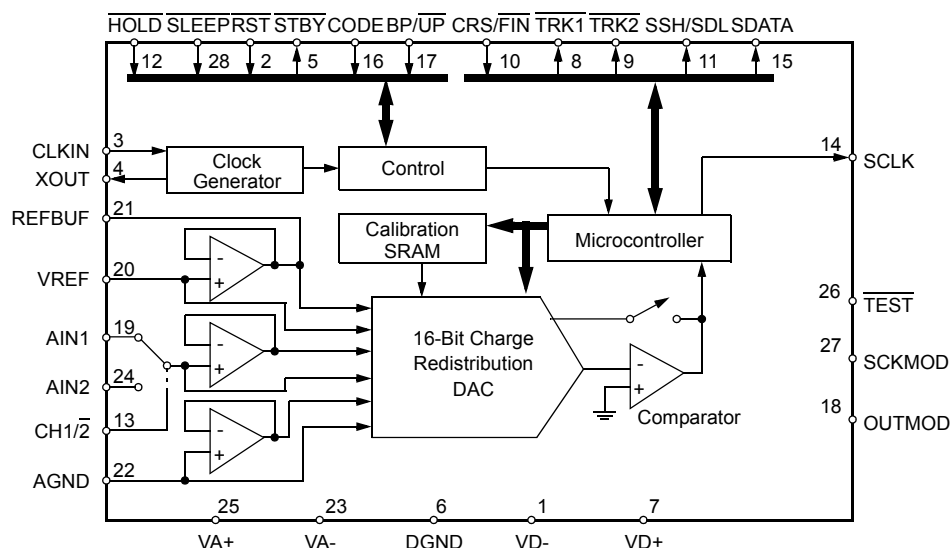

TABLE OF CONTENTS

| | |
|---|-----------|
| 1. CHARACTERISTICS & SPECIFICATIONS | 4 |
| ANALOG CHARACTERISTICS, CS5101A..... | 4 |
| SWITCHING CHARACTERISTICS, CS5101A..... | 6 |
| ANALOG CHARACTERISTICS, CS5102A..... | 7 |
| SWITCHING CHARACTERISTICS, CS5102A..... | 9 |
| SWITCHING CHARACTERISTICS, ALL DEVICES | 11 |
| DIGITAL CHARACTERISTICS, ALL DEVICES..... | 13 |
| RECOMMENDED OPERATING CONDITIONS | 13 |
| ABSOLUTE MAXIMUM RATINGS | 14 |
| 2. OVERVIEW | 15 |
| 3. THEORY OF OPERATION | 15 |
| 3.1 Calibration | 16 |
| 4. FUNCTIONAL DESCRIPTION | 17 |
| 4.1 Initiating Conversions | 17 |
| 4.2 Tracking the Input | 17 |
| 4.3 Master Clock | 18 |
| 4.4 Asynchronous Sampling Considerations | 18 |
| 4.5 Analog Input Range/Coding Format | 19 |
| 4.6 Output Mode Control | 19 |
| 4.6.1 Pipelined Data Transmission | 19 |
| 4.6.2 Register Burst Transmission (RBT) | 20 |
| 4.6.3 Synchronous Self-clocking (SSC) | 20 |
| 4.6.4 Free Run (FRN) | 20 |
| 5. SYSTEM DESIGN USING THE CS5101A & CS5102A | 22 |
| 5.1 System Initialization | 22 |
| 5.2 Single-channel Operation | 23 |
| 6. ANALOG CIRCUIT CONNECTIONS | 23 |
| 6.1 Reference Considerations | 23 |
| 6.2 Analog Input Connection | 24 |
| 6.3 Sleep Mode Operation | 24 |
| 6.4 Grounding & Power Supply Decoupling | 25 |
| 7. CS5101A & CS5102A PERFORMANCE | 26 |
| 7.1 Differential Nonlinearity | 26 |
| 7.2 FFT Tests and Windowing | 28 |
| 7.3 Sampling Distortion | 30 |
| 7.4 Noise | 31 |
| 7.5 Aperture Jitter | 31 |
| 7.6 Power Supply Rejection | 32 |
| 8. PIN DESCRIPTIONS | 33 |
| 8.1 Power Supply Connections | 33 |
| 8.2 Oscillator | 34 |
| 8.3 Digital Inputs | 34 |
| 8.4 Analog Inputs | 35 |
| 8.5 Digital Outputs | 35 |
| 8.6 Analog Outputs | 35 |
| 8.7 Miscellaneous | 35 |
| 9. PARAMETER DEFINITIONS | 36 |
| 10. PACKAGE DIMENSIONS | 37 |
| 11. ORDERING INFORMATION | 38 |
| 12. ENVIRONMENTAL, MANUFACTURING, & HANDLING INFORMATION | 38 |
| 13. REVISIONS | 39 |

LIST OF FIGURES

| | |
|--|----|
| Figure 1. Reset, Calibration, and Control Timing | 10 |
| Figure 2. Serial Communication Timing | 12 |
| Figure 3. Coarse Charge Input Buffers & Charge Redistribution DAC..... | 15 |
| Figure 4. Coarse/Fine Charge Control | 18 |
| Figure 5. Pipelined Data Transmission (PDT) Mode Timing | 20 |
| Figure 6. Register Burst Transmission (RBT) Mode Timing..... | 21 |
| Figure 7. Synchronous Self-clocking (SSC) Mode Timing | 21 |
| Figure 8. Free Run (FRN) Mode Timing..... | 21 |
| Figure 9. CS5101A/CS5102A System Connection Diagram..... | 22 |
| Figure 10. Power-up Reset Circuit | 23 |
| Figure 11. Reference Connections..... | 24 |
| Figure 12. Charge Settling Time | 24 |
| Figure 13. CS5101A DNL Plot - Ambient Temperature at 25 °C | 27 |
| Figure 14. CS5101A DNL Plot - Ambient Temperature at 138 °C | 27 |
| Figure 15. CS5102A DNL Plot - Ambient Temperature at 25 °C | 27 |
| Figure 16. CS5102A DNL Plot - Ambient Temperature at 138 °C | 27 |
| Figure 17. CS5101A DNL Error Distribution..... | 28 |
| Figure 18. CS5102A DNL Error Distribution..... | 28 |
| Figure 19. CS5101A FFT (SSC Mode, 1-Channel)..... | 29 |
| Figure 20. CS5101A FFT (SSC Mode, 1-Channel)..... | 29 |
| Figure 21. CS5102A FFT (SSC Mode, 1-Channel)..... | 29 |
| Figure 22. CS5102A FFT (SSC Mode, 1-Channle)..... | 29 |
| Figure 23. CS5101A Histogram Plot of 8192 Conversion Inputs | 31 |
| Figure 24. CS5102A Histogram Plot of 8192 Conversion Inputs | 31 |
| Figure 25. Power Supply Rejection | 32 |
| Figure 26. CS5101A & CS5102A 28-pin PLCC Pinout | 33 |
| Figure 27. 28-Pin PLCC Mechanical Drawing..... | 37 |

LIST OF TABLES

| | |
|------------------------------------|----|
| Table 1. Output Coding | 19 |
| Table 2. Output Mode Control | 19 |

1. CHARACTERISTICS & SPECIFICATIONS
ANALOG CHARACTERISTICS, CS5101A

(TA = TMIN to TMAX; VA+, VD+ = 5V; VA-, VD- = -5V; VREF = 4.5V; Full-scale Input sine wave, 1 kHz; CLKIN = 8 MHz; fs = 100 kSps; Bipolar Mode; FRN Mode; AIN1 and AIN2 tied together, each channel tested separately; Analog Source Impedance = 50 Ω with 1000 pF to AGND unless otherwise specified)

| Parameter* | CS5101A-J | | | CS5101A-B | | | Unit | |
|--|----------------|-----|-------|------------|-----|-------|-------|-------|
| | Min | Typ | Max | Min | Typ | Max | | |
| Specified Temperature Range | 0 to +70 | | | -40 to +85 | | | °C | |
| Accuracy | | | | | | | | |
| Linearity Error | -J (Note 1) | - | 0.002 | 0.003 | - | 0.002 | 0.003 | %FS |
| | -B | - | 0.001 | 0.002 | - | 0.001 | 0.002 | %FS |
| | Drift (Note 2) | - | ±¼ | - | - | ±¼ | - | ΔLSB |
| Differential Linearity | (Note 3) | 16 | - | - | 16 | - | - | Bits |
| Full-scale Error | -J (Note 1) | - | ±1 | ±4 | - | ±1 | ±4 | LSB |
| | -B | - | ±1 | ±3 | - | ±1 | ±3 | LSB |
| | Drift (Note 2) | - | ±1 | - | - | ±1 | - | ΔLSB |
| Unipolar Offset | -J (Note 1) | - | ±2 | ±5 | - | ±2 | ±5 | LSB |
| | -B | - | ±2 | ±4 | - | ±2 | ±4 | LSB |
| | Drift (Note 2) | - | ±1 | - | - | ±1 | - | ΔLSB |
| Bipolar Offset | -J (Note 1) | - | ±2 | ±5 | - | ±2 | ±5 | LSB |
| | -B | - | ±2 | ±3 | - | ±2 | ±3 | LSB |
| | Drift (Note 2) | - | ±1 | - | - | ±2 | - | ΔLSB |
| Bipolar Negative Full-scale Error | -J (Note 1) | - | ±1 | ±4 | - | ±1 | ±4 | LSB |
| | -B | - | ±1 | ±3 | - | ±1 | ±3 | LSB |
| | Drift (Note 2) | - | ±1 | - | - | ±1 | - | ΔLSB |
| Dynamic Performance (Bipolar Mode) | | | | | | | | |
| Peak Harmonic or Spurious Noise 1-kHz Input | (Note 1) | | | | | | | |
| | -J | 96 | 100 | - | 96 | 100 | - | dB |
| | -B | 98 | 102 | - | 98 | 102 | - | dB |
| 12-kHz Input | -J | 85 | 88 | - | 85 | 88 | - | dB |
| | -B | 85 | 91 | - | 85 | 91 | - | dB |
| Total Harmonic Distortion | -J | - | 0.002 | - | - | 0.002 | - | % |
| | -B | - | 0.001 | - | - | 0.001 | - | % |
| Signal-to-Noise Ratio 0 dB Input | (Note 1) | | | | | | | |
| | -J | 87 | 90 | - | 87 | 90 | - | dB |
| | -B | 90 | 92 | - | 90 | 92 | - | dB |
| -60 dB Input | -J | - | 30 | - | - | 30 | - | dB |
| | -B | - | 32 | - | - | 32 | - | dB |
| Noise | (Note 4) | | | | | | | |
| | Unipolar Mode | - | 35 | - | - | 35 | - | μVrms |
| | Bipolar Mode | - | 70 | - | - | 70 | - | μVrms |

- Notes: 1. Applies after calibration at any temperature within the specified temperature range.
 2. Total drift over specified temperature range after calibration at power-up, at 25° C.
 3. Minimum resolution for which no missing codes is guaranteed over the specified temperature range.
 4. Wideband noise aliased into the baseband, referred to the input.

* Refer to Parameter Definitions (immediately following the pin descriptions at the end of this data sheet).

ANALOG CHARACTERISTICS, CS5101A (Continued)

| Parameter* | Symbol | CS5101A-J | | | CS5101A-B | | | Unit |
|-------------------------------------|----------|-----------|-----|------|------------|-----|------|------|
| | | Min | Typ | Max | Min | Typ | Max | |
| Specified Temperature Range | - | 0 to +70 | | | -40 to +85 | | | °C |
| Analog Input | | | | | | | | |
| Aperture Time | - | - | 25 | - | - | 25 | - | ns |
| Aperture Jitter | - | - | 100 | - | - | 100 | - | ps |
| Input Capacitance (Note 5) | | | | | | | | |
| Unipolar Mode | - | - | 320 | 425 | - | 320 | 425 | pF |
| Bipolar Mode | - | - | 200 | 265 | - | 200 | 265 | pF |
| Conversion and Throughput | | | | | | | | |
| Conversion Time (Note 6) | t_c | - | - | 8.12 | - | - | 8.12 | μs |
| Acquisition Time (Note 7) | t_a | - | - | 1.88 | - | - | 1.88 | μs |
| Throughput (Note 8) | f_{tp} | 100 | - | - | 100 | - | - | kSps |
| Power Supplies | | | | | | | | |
| Power Supply Current (Note 9) | | | | | | | | |
| Positive Analog | I_{A+} | - | 21 | 28 | - | 21 | 28 | mA |
| Negative Analog | I_{A-} | - | -21 | -28 | - | -21 | -28 | mA |
| Positive Digital | I_{D+} | - | 11 | 15 | - | 11 | 15 | mA |
| Negative Digital | I_{D-} | - | -11 | -15 | - | -11 | -15 | mA |
| Power Consumption (Note 9, Note 10) | | | | | | | | |
| (SLEEP High) | P_{do} | - | 320 | 430 | - | 320 | 430 | mW |
| (SLEEP Low) | P_{ds} | - | 1 | - | - | 1 | - | mW |
| Power Supply Rejection (Note 11) | | | | | | | | |
| Positive Supplies | PSR | - | 84 | - | - | 84 | - | dB |
| Negative Supplies | PSR | - | 84 | - | - | 84 | - | dB |

- Notes:
- Applies only in the track mode. When converting or calibrating, input capacitance will not exceed 30 pF.
 - Conversion time scales directly to the master clock speed. The times shown are for synchronous, internal loopback (FRN) mode) with 8.0 MHz CLKIN. In PDT, RBT, and SSC modes, asynchronous delay between the falling edge of HOLD and the start of conversion may add to the apparent conversion time. This delay will not exceed 1.5 master clock cycles + 10 ns. In PDT, RBT, and SSC modes, CLKIN can be increased as long as the HOLD sample rate is 100 kHz max.
 - The CS5101A requires 6 clock cycles of coarse charge, followed by a minimum of 1.125 μs of fine charge. FRN mode allows 9 cycles for fine charge which provides for the minimum 1.125 μs with an 8MHz clock, however; in PDT, RBT, or SSC modes and at clock frequencies of 8 MHz or less, fine charge may be less than 9 clock cycles. This reflects the typical specification (6 clock cycles + 1.125 μs).
 - Throughput is the sum of the acquisition and conversion times. It will vary in accordance with conditions affecting acquisition and conversion times, as described above.
 - All outputs unloaded. All inputs at VD+ or DGND.
 - Power consumption in the sleep mode applies with no master clock applied (CLKIN held high or low).
 - With 300 mV p-p, 1-kHz ripple applied to each supply separately in the bipolar mode. Rejection improves by 6 dB in the unipolar mode to 90 dB. Figure 25 shows a plot of typical power supply rejection versus frequency.

SWITCHING CHARACTERISTICS, CS5101A

(TA = TMIN to TMAX; VA+, VD+ = 5V ±10%; VA-, VD- = -5V ±10%; Inputs: Logic 0 = 0V, Logic 1 = VD+; CL = 50 pF).

| Parameter | Symbol | Min | Typ | Max | Unit |
|---|-------------|---------------|------------|-----------------|-----------|
| CLKIN Period | t_{clk} | 108 | - | 10,000 | ns |
| CLKIN Low Time | t_{clkL} | 37.5 | - | - | ns |
| CLKIN High Time | t_{clkH} | 37.5 | - | - | ns |
| Crystal Frequency (Note 12) | f_{xtal} | 2.0 | - | 9.216 | MHz |
| SLEEP Rising to Oscillator Stable (Note 13) | - | - | 2 | - | ms |
| RST Pulse Width | t_{rst} | 150 | - | - | ns |
| RST to STBY falling | t_{drss} | - | 100 | - | ns |
| RST Rising to STBY Rising | t_{cal} | - | 11,528,160 | - | t_{clk} |
| CH1/2 Edge to TRK1, TRK2 Rising (Note 14) | t_{drsh1} | - | 80 | - | ns |
| CH1/2 Edge to TRK1, TRK2 Falling (Note 14) | t_{dfsh4} | - | - | $68t_{clk}+260$ | ns |
| HOLD to SSH Falling (Note 15) | t_{dfsh2} | - | 60 | - | ns |
| HOLD to TRK1, TRK2 Falling (Note 15) | t_{dfsh1} | $66t_{clk}$ | - | $68t_{clk}+260$ | ns |
| HOLD to TRK1, TRK2, SSH Rising (Note 15) | t_{drsh} | - | 120 | - | ns |
| HOLD Pulse Width (Note 16) | t_{hold} | $1t_{clk}+20$ | - | $63t_{clk}$ | ns |
| HOLD to CH1/2 Edge (Note 15) | t_{dhlri} | 15 | - | $64t_{clk}$ | ns |
| HOLD Falling to CLKIN Falling (Note 16) | t_{hcf} | 95 | - | $1t_{clk}+10$ | ns |

- Notes: 12. External loading capacitors are required to allow the crystal to oscillate. Maximum crystal frequency is 8.0 MHz in FRN mode (100 kSps).
13. With an 8.0 MHz crystal, two 10 pF loading capacitors and a 10 MΩ parallel resistor (see Figure 9).
14. These timings are for FRN mode.
15. SSH only works correctly if HOLD falling edge is within +15 to +30 ns of CH1/2 edge or if CH1/2 edge occurs after HOLD rises to $64t_{clk}$ after HOLD has fallen. These timings are for PDT and RBT modes.
16. When HOLD goes low, the analog sample is captured immediately. To start conversion, HOLD must be latched by a falling edge of CLKIN. Conversion will begin on the next rising edge of CLKIN after HOLD is latched. If HOLD is operated synchronous to CLKIN, the HOLD pulse width may be as narrow as 150 ns for all CLKIN frequencies if CLKIN falls 95 ns after HOLD falls. This ensures that the HOLD pulse will meet the minimum specification for t_{hcf} .

ANALOG CHARACTERISTICS, CS5102A

(TA = TMIN to TMAX; VA+, VD+ = 5V; VA-, VD- = -5V; VREF = 4.5V; Full-scale Input Sine Wave, 200 Hz; CLKIN = 1.6 MHz; fs = 20 kSps; Bipolar Mode; FRN Mode; AIN1 and AIN2 tied together, each channel tested separately; Analog Source Impedance = 50 Ω with 1000 pF to AGND unless otherwise specified)

| Parameter* | CS5102A-J | | | CS5102A-B | | | Unit | |
|---|----------------|-----|-------|------------|-----|-------|--------|-------|
| | Min | Typ | Max | Min | Typ | Max | | |
| Specified Temperature Range | 0 to +70 | | | -40 to +85 | | | °C | |
| Accuracy | | | | | | | | |
| Linearity Error | -J (Note 1) | - | 0.002 | 0.003 | - | 0.002 | 0.003 | %FS |
| | -B | - | 0.001 | 0.0015 | - | 0.001 | 0.0015 | %FS |
| | Drift (Note 2) | - | ±¼ | - | - | ±¼ | - | ΔLSB |
| Differential Linearity | (Note 3) | 16 | - | - | 16 | - | - | Bits |
| Full-scale Error | -J (Note 1) | - | ±2 | ±4 | - | ±2 | ±4 | LSB |
| | -B | - | ±2 | ±3 | - | ±2 | ±3 | LSB |
| | Drift (Note 2) | - | ±1 | - | - | ±1 | - | ΔLSB |
| Unipolar Offset | -J (Note 1) | - | ±1 | ±4 | - | ±1 | ±4 | LSB |
| | -B | - | ±1 | ±3 | - | ±1 | ±3 | LSB |
| | Drift (Note 2) | - | ±1 | - | - | ±1 | - | ΔLSB |
| Bipolar Offset | -J (Note 1) | - | ±1 | ±4 | - | ±1 | ±4 | LSB |
| | -B | - | ±1 | ±3 | - | ±1 | ±3 | LSB |
| | Drift (Note 2) | - | ±1 | - | - | ±2 | - | ΔLSB |
| Bipolar Negative Full-scale Error | -J (Note 1) | - | ±2 | ±4 | - | ±2 | ±4 | LSB |
| | -B | - | ±2 | ±3 | - | ±2 | ±3 | LSB |
| | Drift (Note 2) | - | ±1 | - | - | ±2 | - | ΔLSB |
| Dynamic Performance (Bipolar Mode) | | | | | | | | |
| Peak Harmonic or Spurious Noise | (Note 1) | | | | | | | |
| | -J | 96 | 100 | - | 96 | 100 | - | dB |
| | -B | 98 | 102 | - | 98 | 102 | - | dB |
| Total Harmonic Distortion | -J | - | 0.002 | - | - | 0.002 | - | % |
| | -B | - | 0.001 | - | - | 0.001 | - | % |
| Signal-to-Noise Ratio | (Note 1) | | | | | | | |
| | 0 dB Input | -J | 87 | 90 | - | 87 | 90 | - |
| | -B | 90 | 92 | - | 90 | 92 | - | dB |
| -60 dB Input | -J | - | 30 | - | - | 30 | - | dB |
| | -B | - | 32 | - | - | 32 | - | dB |
| Noise | (Note 4) | | | | | | | |
| | Unipolar Mode | - | 35 | - | - | 35 | - | μVrms |
| | Bipolar Mode | - | 70 | - | - | 70 | - | μVrms |

* Refer to Parameter Definitions (immediately following the pin descriptions at the end of this data sheet).

ANALOG CHARACTERISTICS, CS5102A (Continued)

| Parameter* | Symbol | CS5102A-J | | | CS5102-B | | | Unit |
|--------------------------------------|----------|-----------|------|--------|------------|------|--------|------|
| | | Min | Typ | Max | Min | Typ | Max | |
| Specified Temperature Range | - | 0 to +70 | | | -40 to +85 | | | °C |
| Analog Input | | | | | | | | |
| Aperture Time | - | - | 30 | - | - | 30 | - | ns |
| Aperture Jitter | - | - | 100 | - | - | 100 | - | ps |
| Input Capacitance (Note 5) | | | | | | | | |
| Unipolar Mode | - | - | 320 | 425 | - | 320 | 425 | pF |
| Bipolar Mode | - | - | 200 | 265 | - | 200 | 265 | pF |
| Conversion and Throughput | | | | | | | | |
| Conversion Time (Note 17) | t_c | - | - | 40.625 | - | - | 40.625 | μs |
| Acquisition Time (Note 18) | t_a | - | - | 9.375 | - | - | 9.375 | μs |
| Throughput (Note 19) | f_{tp} | 20 | - | - | 20 | - | - | kSps |
| Power Supplies | | | | | | | | |
| Power Supply Current (Note 20) | | | | | | | | |
| Positive Analog | I_{A+} | - | 2.4 | 3.5 | - | 2.4 | 3.5 | mA |
| Negative Analog | I_{A-} | - | -2.4 | -3.5 | - | -2.4 | -3.5 | mA |
| Positive Digital | I_{D+} | - | 2.5 | 3.5 | - | 2.5 | 3.5 | mA |
| Negative Digital | I_{D-} | - | -1.5 | -2.5 | - | -1.5 | -2.5 | mA |
| Power Consumption (Note 10, Note 20) | | | | | | | | |
| (SLEEP High) | P_{do} | - | 44 | 65 | - | 44 | 65 | mW |
| (SLEEP Low) | P_{ds} | - | 1 | - | - | 1 | - | mW |
| Power Supply Rejection (Note 21) | | | | | | | | |
| Positive Supplies | PSR | - | 84 | - | - | 84 | - | dB |
| Negative Supplies | PSR | - | 84 | - | - | 84 | - | dB |

- Notes: 17. Conversion time scales directly to the master clock speed. The times shown are for synchronous, internal loopback (FRN) mode. In PDT, RBT, and SSC modes, asynchronous delay between the falling edge of HOLD and the start of conversion may add to the apparent conversion time. This delay will not exceed 1 master clock cycle + 140 ns.
18. The CS5102A requires 6 clock cycles of coarse charge, followed by a minimum of 5.625 μs of fine charge. FRN mode allows 9 cycles for fine charge which provides for the minimum 5.625 μs with a 1.6 MHz clock, however; in PDT, RBT, or SSC modes and at clock frequencies of less than 1.6 MHz, fine charge may be less than 9 clock cycles.
19. Throughput is the sum of the acquisition and conversion times. It will vary in accordance with conditions affecting acquisition and conversion times, as described above.
20. All outputs unloaded. All inputs at VD+ or DGND. See table below for power dissipation versus clock frequency.
21. With 300 mV p-p, 1-kHz ripple applied to each supply separately in the bipolar mode. Rejection improves by 6 dB in the unipolar mode to 90 dB. Figure 25 shows a plot of typical power supply rejection versus frequency.

| Typical Power (mW) | CLKIN (MHz) |
|--------------------|-------------|
| 34 | 0.8 |
| 37 | 1.0 |
| 39 | 1.2 |
| 41 | 1.4 |
| 44 | 1.6 |

SWITCHING CHARACTERISTICS, CS5102A

(TA = TMIN to TMAX; VA+, VD+ = 5V ±10%; VA-, VD- = -5V ±10%; Inputs: Logic 0 = 0V, Logic 1 = VD+; CL = 50 pF).

| Parameter | Symbol | Min | Typ | Max | Unit |
|---|-------------|---------------|-----------|-----------------|-----------|
| CLKIN Period (Note 22) | t_{clk} | 0.5 | - | 10 | μs |
| CLKIN Low Time | t_{clkl} | 200 | - | - | ns |
| CLKIN High Time | t_{clkh} | 200 | - | - | ns |
| Crystal Frequency (Note 22, Note 23) | f_{xtal} | 0.9 | 1.6 | 2.0 | MHz |
| SLEEP Rising to Oscillator Stable (Note 24) | - | - | 20 | - | ms |
| RST Pulse Width | t_{rst} | 150 | - | - | ns |
| RST to STBY falling | t_{drrs} | - | 100 | - | ns |
| RST Rising to STBY Rising | t_{cal} | - | 2,882,040 | - | t_{clk} |
| CH1/2 Edge to TRK1, TRK2 Rising (Note 25) | t_{drsh1} | - | 80 | - | ns |
| CH1/2 Edge to TRK1, TRK2 Falling (Note 25) | t_{dfsh4} | - | - | $68t_{clk}+260$ | ns |
| HOLD to SSH Falling (Note 26) | t_{dfsh2} | - | 60 | - | ns |
| HOLD to TRK1, TRK2 Falling (Note 26) | t_{dfsh1} | $66t_{clk}$ | - | $68t_{clk}+260$ | ns |
| HOLD to TRK1, TRK2, SSH Rising (Note 26) | t_{drsh} | - | 120 | - | ns |
| HOLD Pulse Width (Note 27) | t_{hold} | $1t_{clk}+20$ | - | $63t_{clk}$ | ns |
| HOLD to CH1/2 Edge (Note 26) | t_{dhlri} | 15 | - | $64t_{clk}$ | ns |
| HOLD Falling to CLKIN Falling (Note 27) | t_{hcf} | 55 | - | $1t_{clk}+10$ | ns |

Notes: 22. Minimum CLKIN period is 0.625 ms in FRN mode (20 kSps).

23. External loading capacitors are required to allow the crystal to oscillate. Maximum crystal frequency is 1.6 MHz in FRN mode (20 kSps).

24. With a 2.0 MHz crystal, two 33 pF loading capacitors and a 10 MΩ parallel resistor (see Figure 9).

25. These timings are for FRN mode.

 26. SSH only works correctly if HOLD falling edge is within +15 to +30 ns of CH1/2 edge or if CH1/2 edge occurs after HOLD rises to $64t_{clk}$ after HOLD has fallen. These timings are for PDT and RBT modes.

 27. When HOLD goes low, the analog sample is captured immediately. To start conversion, HOLD must be latched by a falling edge of CLKIN. Conversion will begin on the next rising edge of CLKIN after HOLD is latched. If HOLD is operated synchronous to CLKIN, the HOLD pulse width may be as narrow as 150 ns for all CLKIN frequencies if CLKIN falls 55 ns after HOLD falls. This ensures that the HOLD pulse will meet the minimum specification for t_{hcf} .

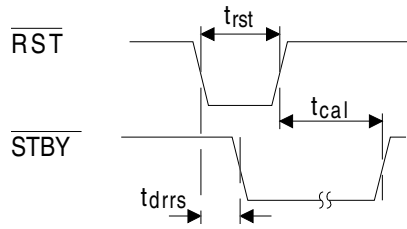
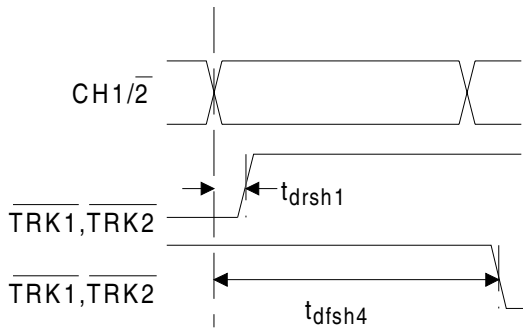
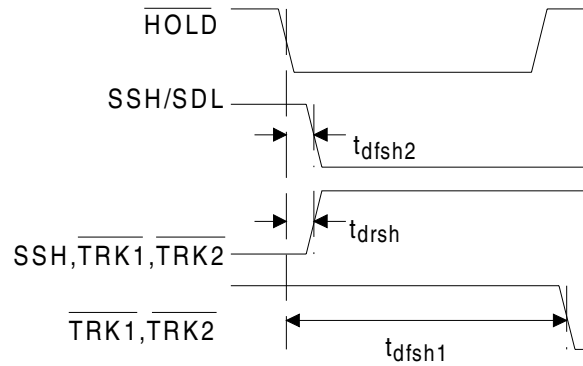
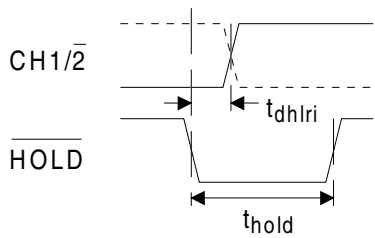
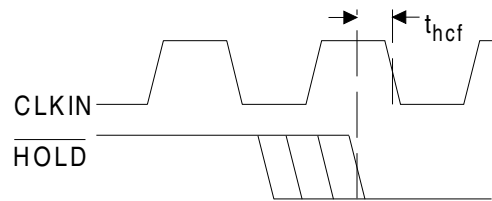

Reset and Calibration Timing

a. FRN Mode

b. PDT, RBT Mode
Control Output Timing

Channel Selection Timing

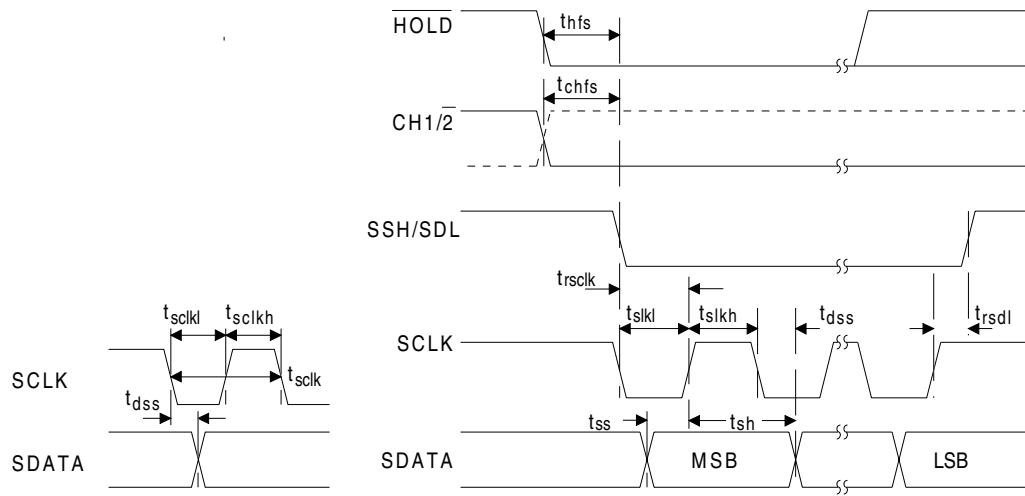
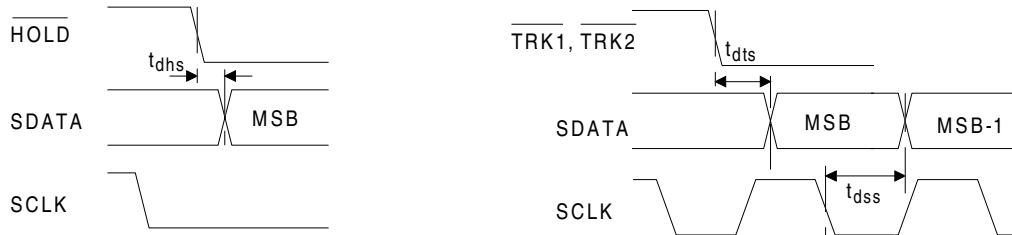
Start Conversion Timing
Figure 1. Reset, Calibration, and Control Timing

SWITCHING CHARACTERISTICS, ALL DEVICES

(TA = TMIN to TMAX; VA+, VD+ = 5V ±10%; VA-, VD- = -5V ±10%; Inputs: Logic 0 = 0V, Logic 1 = VD+; CL = 50 pF).

| Parameter | Symbol | Min | Typ | Max | Unit |
|---|--|--------------------------|--------------------------|----------------------------------|-----------|
| PDT & RBT Modes | | | | | |
| SCLK Input Pulse Period | t_{sclk} | 200 | - | - | ns |
| SCLK Input Pulse Width Low | $t_{sclk\ell}$ | 50 | - | - | ns |
| SCLK Input Pulse Width High | t_{sclkh} | 50 | - | - | ns |
| SCLK Input Falling to SDATA Valid | t_{dss} | - | 100 | 150 | ns |
| \overline{HOLD} Falling to SDATA Valid | t_{dhs} | - | 140 | 230 | ns |
| TRK1, TRK2 Falling to SDATA Valid | t_{dts} | - | 65 | 125 | ns |
| FRN & SSC Modes | | | | | |
| SCLK Output Pulse Width Low | t_{slkl} | - | $2t_{clk}$ | - | t_{clk} |
| SCLK Output Pulse Width High | t_{slkh} | - | $2t_{clk}$ | - | t_{clk} |
| SDATA Valid Before Rising SCLK | t_{ss} | $2t_{clk}-100$ | - | - | ns |
| SDATA Valid After Rising SCLK | t_{sh} | $2t_{clk}-100$ | - | - | ns |
| SDL Falling to 1 st Rising SCLK | t_{rsclk} | $66t_{clk}$ | $2t_{clk}$ | $68t_{clk}+260$ | ns |
| Last Rising SCLK to SDL Rising | CS5101A t_{rsdl} CS5102A t_{rsdl} | - - | $2t_{clk}$ $2t_{clk}$ | $2t_{clk}+165$ $2t_{clk}+200$ | ns |
| \overline{HOLD} Falling to 1 st Falling SCLK | CS5101A t_{hfs} CS5102A t_{hfs} | $6t_{clk}$ $6t_{clk}$ | - - | $8t_{clk}+165$ $8t_{clk}+200$ | ns |
| CH1/2 Edge to 1 st Falling SCLK | t_{dhlri} | - | $7t_{clk}$ | $64t_{clk}$ | t_{clk} |

 Notes: 28. Only valid for $\overline{TRK1}$, $\overline{TRK2}$ falling when SCLK is low. If SCLK is high when $\overline{TRK1}$, $\overline{TRK2}$ falls, then SDATA is valid t_{dss} time after the next falling SCLK.

a. SCLK Input (PDT & RBT Modes)
b. SCLK Output (FRN & SSC Modes)
Serial Data Timing

a. Pipelined Data Transmission (PDT)
b. Register Burst Transmission (RBT)
Data Transmission Timing
Figure 2. Serial Communication Timing

DIGITAL CHARACTERISTICS, ALL DEVICES

(TA = TMIN to TMAX; VA+, VD+ = 5V ±10%; VA-, VD- = -5V ±10%)

| Parameter | Symbol | Min | Typ | Max | Unit |
|--|------------------|------------|-----|-----|------|
| Calibration Memory Retention Power Supply Voltage VA+ and VD+ (Note 29) | V _{MR} | 2.0 | - | - | V |
| High-level Input Voltage | V _{IH} | 2.0 | - | - | V |
| Low-level Input Voltage | V _{IL} | - | - | 0.8 | V |
| High-level Output Voltage (Note 30) | V _{OH} | (VD+) -1.0 | - | - | V |
| Low-level Output Voltage (except XOUT) I _{out} = 1.6 mA | V _{OL} | - | - | 0.4 | V |
| Input Leakage Current | I _{in} | - | - | 10 | μA |
| Digital Output Pin Capacitance | C _{out} | - | 9 | - | pF |

29. VA- and VD- can be any value from 0 to +5V for memory retention. Neither VA- nor VD- should be allowed to go positive. AIN1, AIN2, or VREF must not be greater than VA+ or VD+. This parameter is guaranteed by characterization.

30. I_{OUT} = -100 μA. This specification guarantees TTL compatibility (V_{OH} = 2.4V @ I_{OUT} = -40 μA).

RECOMMENDED OPERATING CONDITIONS

(AGND, DGND = 0V, see Note 31)

| Parameter | Symbol | Min | Typ | Max | Unit |
|------------------------------|------------------|-------|------|-----------|------|
| DC Power Supplies: | | | | | |
| Positive Digital | VD+ | 4.5 | 5.0 | VA+ | V |
| Negative Digital | VD- | -4.5 | -5.0 | -5.5 | V |
| Positive Analog | VA+ | 4.5 | 5.0 | 5.5 | V |
| Negative Analog | VA- | -4.5 | -5.0 | -5.5 | V |
| Analog Reference Voltage | VREF | 2.5 | 4.5 | (VA+)-0.5 | V |
| DC Power Supplies: (Note 32) | | | | | |
| Unipolar | V _{AIN} | AGND | - | VREF | V |
| Bipolar | V _{AIN} | -VREF | - | VREF | V |

31. All voltages with respect to ground.

32. The CS5101A and CS5102A can accept input voltages up to the analog supplies (VA+ and VA-). They will produce an output of all 1s for input above VREF and all 0s for inputs below AGND in unipolar mode, and -VREF in bipolar mode, with binary coding (CODE = low).

ABSOLUTE MAXIMUM RATINGS

(AGND, DGND = 0V, all voltages with respect to ground.)

| Parameter | Symbol | Min | Typ | Max | Unit |
|--|-----------|-------------|-----|-------------|------|
| DC Power Supplies: (Note 33) | | | | | |
| Positive Digital | VD+ | -0.3 | - | 6.0 | V |
| Negative Digital | VD- | 0.3 | - | -6.0 | V |
| Positive Analog | VA+ | -0.3 | - | 6.0 | V |
| Negative Analog | VA- | 0.3 | - | -6.0 | V |
| Input Current, Any Pin Except Supplies (Note 34) | I_{IN} | - | - | ±10 | mA |
| Analog Input Voltage (AIN and VREF pins) | V_{INA} | (VA-) - 0.3 | - | (VA+) + 0.3 | V |
| Digital Input Voltage | V_{IND} | -0.3 | - | (VA+) + 0.3 | V |
| Ambient Operating Temperature | T_A | -55 | - | 125 | °C |
| Storage Temperature | T_{stg} | -65 | - | 150 | °C |

Notes: 33. In addition, VD+ must not be greater than (VA+) + 0.3 V.

34. Transient currents of up to 100 mA will not cause SCR latch-up

WARNING: Operation beyond these limits may result in permanent damage to the device.

2. OVERVIEW

The CS5101A and CS5102A are 2-channel, 16-bit A/D converters. The devices include an inherent sample/hold and an on-chip analog switch for 2-channel operation. Both channels can thus be sampled and converted at rates up to 50 kSps each (CS5101A) or 10 kSps each (CS5102A). Alternatively, each of the devices can be operated as a single channel ADC operating at 100 kSps (CS5101A) or 20 kSps (CS5102A).

Both the CS5101A and CS5102A can be configured to accept either unipolar or bipolar input ranges, and data is output serially in either binary or 2's complement coding. The devices can be configured in 3 different output modes, as well as an internal, synchronous loopback mode. The CS5101A and CS5102A provide coarse charge/fine charge control, to allow accurate tracking of high-slew signals.

3. THEORY OF OPERATION

The CS5101A and CS5102A implement the successive approximation algorithm using a charge redistribution architecture. Instead of the traditional resistor network, the DAC is an array of binary-weighted capacitors. All capacitors in the array share a common node at the comparator's input.

As shown in Figure 3, their other terminals are capable of being connected to AGND, VREF, or AIN (1 or 2). When the device is not calibrating or converting, all capacitors are tied to AIN. Switch S1 is closed and the charge on the array, tracks the input signal.

When the conversion command is issued, switch S1 opens. This traps the charge on the comparator side of the capacitor array and creates a floating node at the comparator's input. The conversion algorithm operates on this fixed charge, and the signal at the analog input pin is ignored. In effect, the entire DAC capacitor array serves as analog memory during conversion much like the hold capacitor in a sample/hold amplifier.

The conversion consists of manipulating the free plates of the capacitor array to VREF and AGND to form a capacitive divider. Since the charge at the floating node remains fixed, the voltage at that point depends on the proportion of capacitance tied to VREF versus AGND. The successive approximation algorithm is used to find the proportion of capacitance, which when connected to the reference will drive the voltage at the floating node to zero. That binary fraction of capacitance represents the converter's digital output.

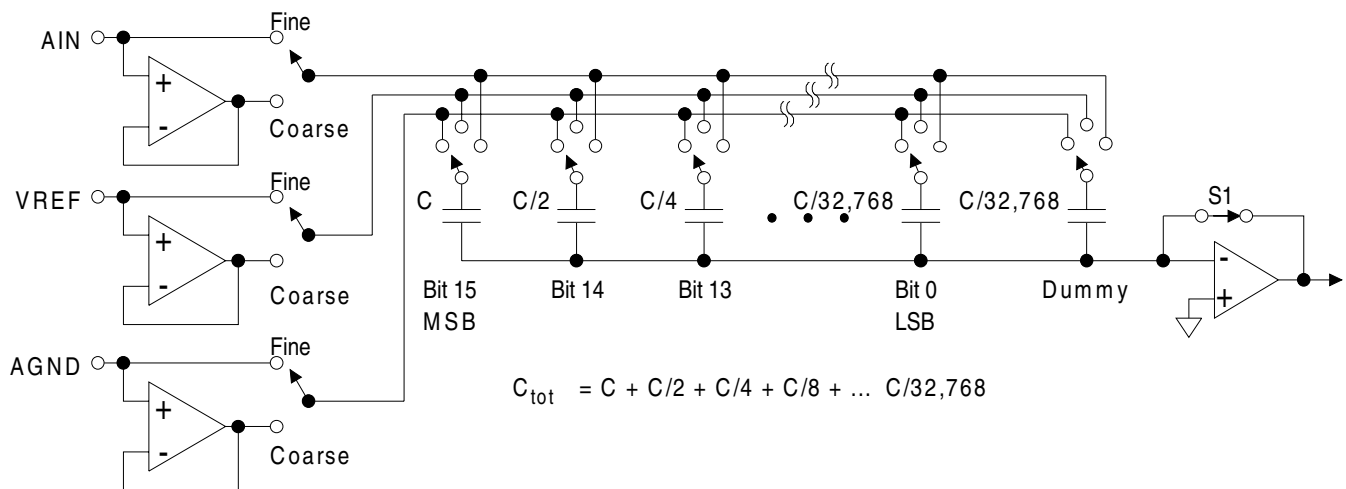

Figure 3. Coarse Charge Input Buffers & Charge Redistribution DAC

3.1 Calibration

The ability of the CS5101A or the CS5102A to convert accurately to 16-bits clearly depends on the accuracy of its comparator and DAC. Each device utilizes an “auto-zeroing” scheme to null errors introduced by the comparator. All offsets are stored on the capacitor array while in the track mode and are effectively subtracted from the input signal when a conversion is initiated. Auto-zeroing enhances power supply rejection at frequencies well below the conversion rate.

To achieve 16-bit accuracy from the DAC, the CS5101A and CS5102A use a novel self-calibra-

tion scheme. Each bit capacitor shown in Figure 3 actually consists of several capacitors in parallel which can be manipulated to adjust the overall bit weight. An on-chip microcontroller precisely adjusts each capacitor with a resolution of 18 bits.

The CS5101A and CS5102A should be reset upon power-up, thus initiating a calibration cycle. The device then stores its calibration coefficients in on-chip SRAM. When the CS5101A and CS5102A are in power-down mode ($\overline{\text{SLEEP}}$ low), they retain the calibration coefficients in memory, and need not be recalibrated when normal operation is resumed.

4. FUNCTIONAL DESCRIPTION

Monolithic design and inherent sampling architecture make the CS5101A and CS5102A extremely easy to use.

4.1 Initiating Conversions

A falling transition on the HOLD pin places the input in the hold mode and initiates a conversion cycle. The charge is trapped on the capacitor array the instant HOLD goes low. The device will complete conversion of the sample within 66 master clock cycles, then automatically return to the track mode. After allowing a short time for acquisition, the device will be ready for another conversion.

In contrast to systems with separate track-and-holds and A/D converters, a sampling clock can simply be connected to the HOLD input. The duty cycle of this clock is not critical. The HOLD input is latched internally by the master clock, so it need only remain low for $1/f_{\text{clk}} + 20 \text{ ns}$, but no longer than the minimum conversion time minus two master clocks or an additional conversion cycle will be initiated with inadequate time for acquisition. In Free Run mode, $\text{SCKMOD} = \text{OUTMOD} = 0$, the device will convert at a rate of $\text{CLKIN}/80$, and the HOLD input is ignored.

As with any high-resolution A-to-D system, it is recommended that sampling is synchronized to the master system clock in order to minimize the effects of clock feed through. However, the CS5101A and CS5102A may be operated entirely asynchronous to the master clock if necessary.

4.2 Tracking the Input

Upon completing a conversion cycle the CS5101A and CS5102A immediately return to the track mode. The $\text{CH1}/\overline{2}$ pin directly controls the input switch, and therefore directly determines which channel will be tracked. Ideally, the $\text{CH1}/\overline{2}$ pin should be switched during the conversion cycle, thereby nullifying the input mux switching time, and guaranteeing a stable input at the start of acquisition. If, however, the $\text{CH1}/\overline{2}$ control is changed during the acquisition phase, adequate coarse charge and fine charge time must be allowed before initiating conversion.

When the CS5101A or the CS5102A enters tracking mode, it uses an internal input buffer amplifier

to provide the bulk of the charge on the capacitor array (coarse-charge), thereby reducing the current load on the external analog circuitry. Coarse-charge is internally initiated for 6 clock cycles at the end of every conversion. The buffer amplifier is then bypassed, and the capacitor array is directly connected to the input. This is referred to as fine-charge, during which the charge on the array is allowed to accurately settle to the input voltage (see Figure 12).

With a full-scale input step, the coarse-charge input buffer of the CS5101A will charge the capacitor array within 1% in 650 ns. The converter timing allows 6 clock cycles for coarse charge settling time. When the CS5101A switches to fine-charge mode, its slew rate is somewhat reduced. In fine-charge, the CS5101A can slew at $2 \text{ V}/\mu\text{s}$ in unipolar mode. In bipolar mode, only half the capacitor array is connected to the analog input, so the CS5101A can slew at $4\text{V}/\mu\text{s}$.

With a full-scale input step, the coarse-charge input buffer of the CS5102A will charge the capacitor array within 1% in $3.75 \mu\text{s}$. The converter timing allows 6 clock cycles for coarse charge settling time. When in fine-charge mode, the CS5102A can slew at $0.4 \text{ V}/\mu\text{s}$ in unipolar mode; and at $0.8 \text{ V}/\mu\text{s}$ in bipolar mode.

Acquisition of fast slewing signals can be hastened if the voltage change occurs during or immediately following the conversion cycle. For instance, in multiple channel applications (using either the device's internal channel selector or an external MUX), channel selection should occur while the CS5101A or the CS5102A is converting. Multiplexer switching and settling time is thereby removed from the overall throughput equation.

If the input signal changes drastically during the acquisition period (such as changing the signal source), the device should be in coarse-charge for an adequate period following the change. The CS5101A and CS5102A can be forced into coarse-charge by bringing $\text{CRS}/\overline{\text{FIN}}$ high. The buffer amplifier is engaged when $\text{CRS}/\overline{\text{FIN}}$ is high, and may be switched in any number of times during tracking. If $\text{CRS}/\overline{\text{FIN}}$ is held low, the CS5101A and CS5102A will only coarse-charge for the first 6 clock cycles following a conversion, and will stay in

fine-charge until $\overline{\text{HOLD}}$ goes low. To get an accurate sample using the CS5101A, at least 750 ns of coarse-charge, followed by 1.125 μs of fine-charge is required before initiating a conversion. If coarse charge is not invoked, then up to 25 μs should be allowed after a step change input for proper acquisition. To get an accurate sample using the CS5102A, at least 3.75 μs of coarse-charge, fol-

lowed by 5.625 μs of fine-charge is required before initiating a conversion (see Figure 4). If coarse charge is not invoked, then up to 125 μs should be allowed after a step change input for proper acqui-sition. The $\overline{\text{CRS}}/\overline{\text{FIN}}$ pin must be low prior to $\overline{\text{HOLD}}$ becoming active and be held low during conver-

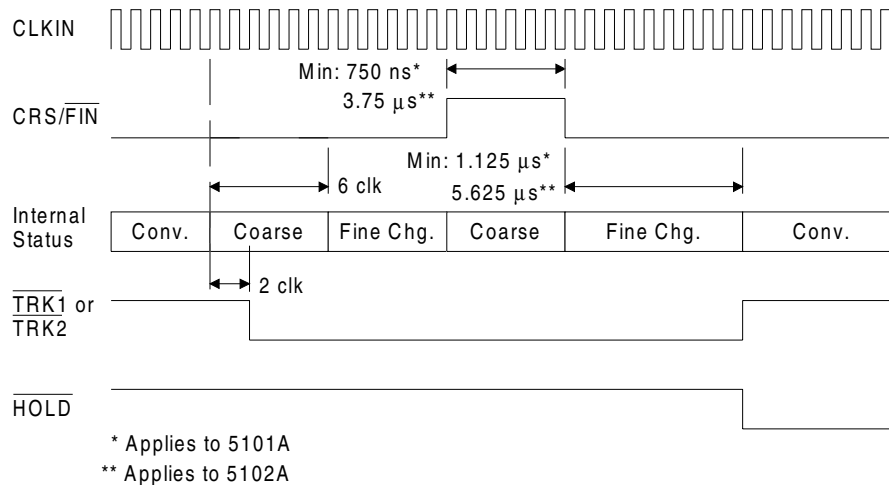

Figure 4. Coarse/Fine Charge Control

4.3 Master Clock

The CS5101A and CS5102A can operate either from an externally-supplied master clock, or from their own crystal oscillator (with a crystal). To enable the internal crystal oscillator, simply tie a crystal across the XOUT and CLKIN pins and add 2 capacitors and a resistor, as shown on the system connection diagram in Figure 9.

Calibration and conversion times directly scale to the master clock frequency. The CS5101A can operate with clock or crystal frequencies up to 9.216 MHz (8.0 MHz in FRN mode). This allows maximum throughput of up to 50 kSps per channel in dual-channel operation, or 100 kSps in a single-channel configuration. The CS5102A can operate with clock or crystal frequencies up to 2.0 MHz (1.6 MHz in FRN mode). This allows maximum throughput of up to 10 kSps per channel in dual-channel operation, or 20 kSps in a single channel configuration. For 16-bit performance a 1.6 MHz clock is recommended. This 1.6 MHz clock yields a maximum throughput of 20 kSps in a single-channel configuration.

4.4 Asynchronous Sampling Considerations

When $\overline{\text{HOLD}}$ goes low, the analog sample is captured immediately. The $\overline{\text{HOLD}}$ signal is latched by the next falling edge of CLKIN, and conversion then starts on the subsequent rising edge. If $\overline{\text{HOLD}}$ is asynchronous to CLKIN, then there will be a 1.5-CLKIN-cycle uncertainty as to when conversion starts. Considering the CS5101A with an 8 MHz CLKIN, with a 100 kHz $\overline{\text{HOLD}}$ signal, then this 1.5-CLKIN uncertainty will result in a 1.5-CLKIN-period possible reduction in fine charge time for the next conversion.

This reduced fine charge time will be less than the minimum specification. If the CLKIN frequency is increased slightly (for example, to 8.192 MHz) then sufficient fine charge time will always occur. The maximum frequency for CLKIN is specified at 9.216 MHz. It is recommended that for asynchronous operation at 100 kSps, CLKIN should be between 8.192 MHz and 9.216 MHz.

4.5 Analog Input Range/Coding Format

The reference voltage directly defines the input voltage range in both the unipolar and bipolar configurations. In the unipolar configuration (BP/UP low), the first code transition occurs 0.5 LSB above AGND, and the final code transition occurs 1.5 LSBs below VREF. In the bipolar configuration (BP/UP high), the first code transition oc-

curs 0.5 LSB above -VREF and the last transition occurs 1.5 LSBs below +VREF. The CS5101A and CS5102A can output data in either 2's complement, or binary format. If the CODE pin is high, the output is in 2's complement format with a range of -32,768 to +32,767. If the CODE pin is low, the output is in binary format with a range of 0 to +65,535. See Table 1 for output coding.

Table 1. Output Coding

| Unipolar Input Voltage | Offset Binary | Two's Complement | Bipolar Input Voltage |
|------------------------|---------------|------------------|-----------------------|
| >(VREF-1.5 LSB) | FFFF | 7FFF | >(VREF-1.5 LSB) |
| VREF-1.5 LSB | FFFF FFFE | 7FFF 7FFE | VREF-1.5 LSB |
| (VREF/2)-0.5 LSB | 8000 7FFF | 0000 FFFF | -0.5 LSB |
| +0.5 LSB | 0001 0000 | 8001 8000 | -VREF+0.5 LSB |
| <(+0.5 LSB) | 0000 | 8000 | <(-VREF+0.5 LSB) |

4.6 Output Mode Control

The CS5101A and CS5102A can be configured in three different output modes, as well as an internal, synchronous loop-back mode. This allows great flexibility for design into a wide variety of systems. The operating mode is selected by setting the

states of the SCKMOD and OUTMOD pins. In all modes, data is output on SDATA, starting with the MSB. Each subsequent data bit is updated on the falling edge of SCLK.

Table 2. Output Mode Control

| MODE | SCKMOD | OUTMOD | SCLK | CH1/2 | HOLD |
|------|--------|--------|--------|--------|-------|
| PDT | 1 | 1 | Input | Input | Input |
| RBT | 1 | 0 | Input | Input | Input |
| SSC | 0 | 1 | Output | Input | Input |
| FRN | 0 | 0 | Output | Output | X |

When SCKMOD is high, SCLK is an input, allowing the data to be clocked out with an external serial clock at rates up to 5 MHz. Additional clock edges after #16 will clock out logic 1s on SDATA. Tying SCKMOD low reconfigures SCLK as an output, and the converter clocks out each bit as it is determined during the conversion process, at a rate of 1/4 the master clock speed. Table 2 shows an overview of the different states of SCKMOD and OUTMOD, and the corresponding output modes.

4.6.1 Pipelined Data Transmission

PDT mode is selected by tying both SCKMOD and OUTMOD high. In PDT mode, the SCLK pin is an input. Data is registered during conversion, and output during the following conversion cycle. HOLD must be brought low, initiating another conversion, before data from the previous conversion is available on SDATA. If all the data has not been clocked out before the next falling edge of HOLD, the old data will be lost (Figure 5).

4.6.2 Register Burst Transmission (RBT)

RBT mode is selected by tying SCKMOD high, and OUTMOD low. As in PDT mode, SCLK is an input, however data is available immediately following conversion, and may be clocked out the moment TRK1 or TRK2 falls. The falling edge of HOLD clears the output buffer, so any unread data will be lost. A new conversion may be initiated before all the data has been clocked out if the unread data bits are not important (Figure 6).

4.6.3 Synchronous Self-clocking (SSC)

SSC mode is selected by tying SCKMOD low, and OUTMOD high. In SSC mode, SCLK is an output, and will clock out each bit of the data as it's being converted. SCLK will remain high between conversions, and run at a rate of 1/4 the master clock speed for 16 low pulses during conversion (Figure 7).

The SSH/SDL goes low coincident with the first falling edge of SCLK, and returns high 2 CLKIN cycles after the last rising edge of SCLK. This signal frames the 16 data bits and is useful for interfacing

to shift registers (e.g. 74HC595) or to DSP serial ports.

4.6.4 Free Run (FRN)

Free Run is the internal, synchronous loopback mode. FRN mode is selected by tying SCKMOD and OUTMOD low. SCLK is an output, and operates exactly the same as in the SSC mode. In Free Run mode, the converter initiates a new conversion every 80 master clock cycles, and alternates between channel 1 and channel 2. HOLD is disabled, and should be tied to either VD+ or DGND. CH1/2 is an output, and will change at the start of each new conversion cycle, indicating which channel will be tracked after the current conversion is finished (Figure 8).

The SSH/SDL goes low coincident with the first falling edge of SCLK, and returns high 2 CLKIN cycles after the last rising edge of SCLK. This signal frames the 16 data bits and is useful for interfacing to shift registers (e.g. 74HC595) or to DSP serial ports.

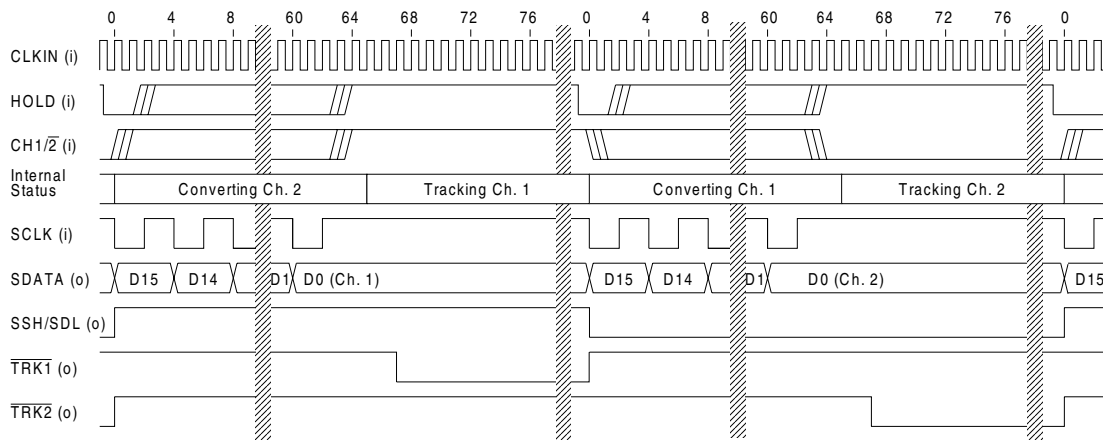
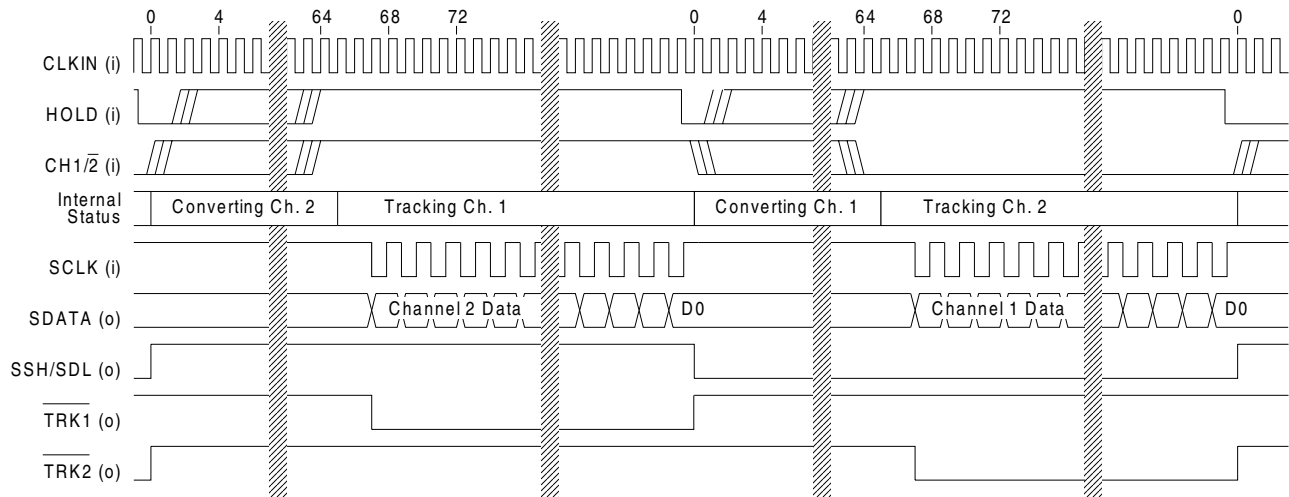
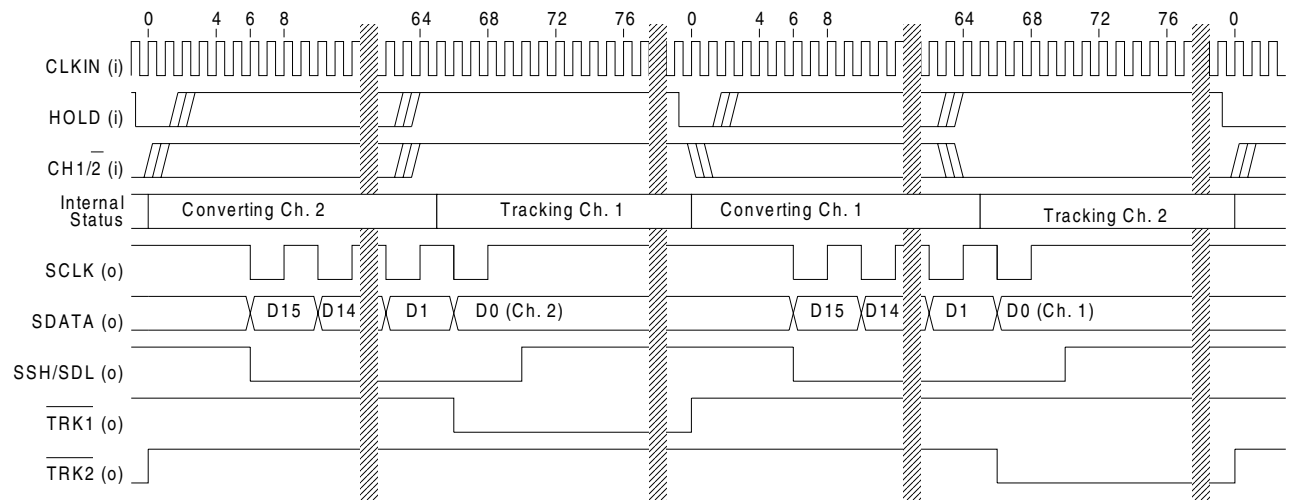
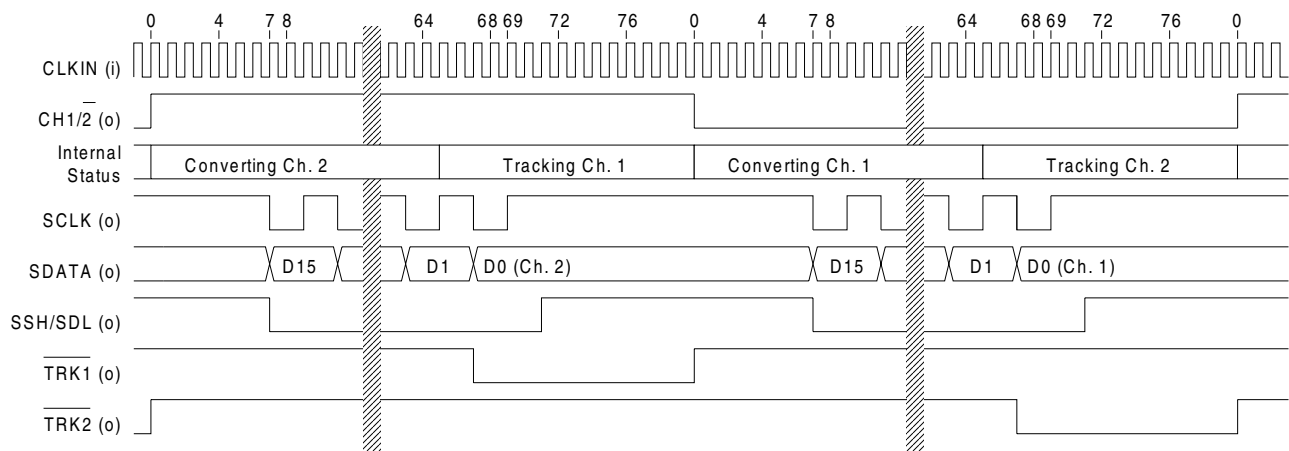

Figure 5. Pipelined Data Transmission (PDT) Mode Timing

Figure 6. Register Burst Transmission (RBT) Mode Timing

Figure 7. Synchronous Self-clocking (SSC) Mode Timing

Figure 8. Free Run (FRN) Mode Timing

5. SYSTEM DESIGN USING THE CS5101A & CS5102A

Figure 9 shows a general system connection diagram for the CS5101A and CS5102A.

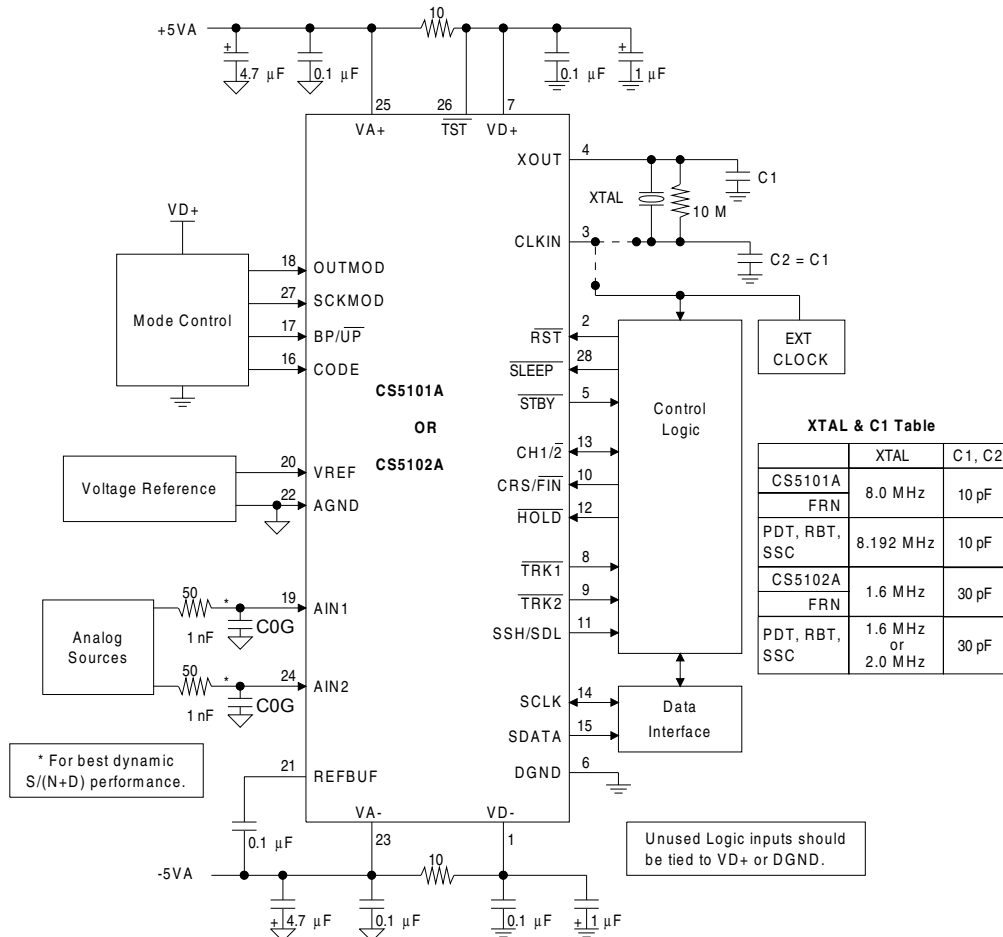

Figure 9. CS5101A/CS5102A System Connection Diagram

5.1 System Initialization

Upon power up, the CS5101A and CS5102A must be reset to guarantee a consistent starting condition and to initially calibrate the device. Due to each device's low power dissipation and low temperature drift, no warm-up time is required before reset to accommodate any self-heating effects. However, the voltage reference input should have stabilized to within 0.25% of its final value before $\overline{\text{RST}}$ rises to guarantee an accurate calibration. Later, the CS5101A and CS5102A may be reset at any time to initiate a single full calibration.

When $\overline{\text{RST}}$ is brought low all internal logic clears. When $\overline{\text{RST}}$ returns high on the CS5101A, a calibration cycle begins which takes 11,528,160 master clock cycles to complete (approximately

1.4 seconds with an 8 MHz master clock). The calibration cycle on the CS5102A takes 2,882,040 master clock cycles to complete (approximately 1.8 seconds with a 1.6 MHz master clock). The CS5101A's and CS5102A's $\overline{\text{STBY}}$ output remains low throughout the calibration sequence, and a rising transition indicates the device is ready for normal operation. While calibrating, the CS5101A and CS5102A will ignore changes on the $\overline{\text{HOLD}}$ input.

To perform the reset function, a simple power-on reset circuit can be built using a resistor and capacitor as shown in Figure 10. The resistor should be less than or equal to 10 kΩ. The system power supplies, voltage reference, and clock should all be established prior $\overline{\text{RST}}$ rising.

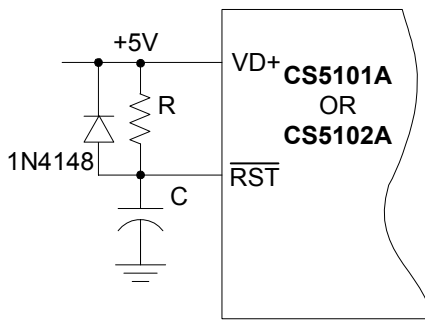

Figure 10. Power-up Reset Circuit

5.2 Single-channel Operation

The CS5101A and CS5102A can alternatively be used to sample one channel by tying the CH1/2 input high or low. The unused AIN pin should be tied to the analog input signal or to AGND. (If operating in free run mode, AIN1 and AIN2 must be tied to the same source, as CH1/2 is reconfigured as an output.)

6. ANALOG CIRCUIT CONNECTIONS

Most popular successive approximation A/D converters generate dynamic loads at their analog connections. The CS5101A and CS5102A internally buffer all analog inputs (AIN1, AIN2, VREF, and AGND) to ease the demands placed on external circuitry. However, accurate system operation still requires careful attention to details at the design stage regarding source impedances as well as grounding and decoupling schemes.

6.1 Reference Considerations

An application note titled [AN004, Voltage References for the CS5012A / CS5014 / CS5016 / CS5101A / CS5102A / CS5126 Series of A/D Converters](#) is available for the CS5101A and CS5102A. In addition to working through a reference circuit design example, it offers several built-and-tested reference circuits.

During conversion, each capacitor of the calibrated capacitor array is switched between VREF and AGND in a manner determined by the successive-approximation algorithm. The charging and discharging of the array results in a current load at the reference. The CS5101A and CS5102A each in-

clude an internal buffer amplifier to minimize the external reference circuit's drive requirement and preserve the reference's integrity. Whenever the array is switched during conversion, the buffer is used to coarse-charge the array thereby providing the bulk of the necessary charge. The appropriate array capacitors are then switched to the unbuffered VREF pin to avoid any errors due to offsets and/or noise in the buffer.

The external reference circuitry need only provide the residual charge required to fully charge the array after coarse-charging from the buffer. This creates an ac current load as the CS5101A and CS5102A sequence through conversions. The reference circuitry must have a low enough output impedance to drive the requisite current without changing its output voltage significantly. As the analog input signal varies, the switching sequence of the internal capacitor array changes. The current load on the external reference circuitry thus varies in response with the analog input. Therefore, the external reference must not exhibit significant peaking in its output impedance characteristic at signal frequencies or their harmonics.

A large capacitor connected between VREF and AGND can provide sufficiently low output impedance at the high end of the frequency spectrum, while almost all precision references exhibit extremely low output impedance at DC. The presence of large capacitors on the output of some voltage references, however, may cause peaking in the output impedance at intermediate frequencies. Care should be exercised to ensure that significant peaking does not exist or that some form of compensation is provided to eliminate the effect.

The magnitude of the current load on the external reference circuitry will scale to the master clock frequency. At the full-rated 9.216 MHz clock (CS5101A), the reference must supply a maximum load current of 20 μA peak-to-peak (2 μA typical). An output impedance of 2 Ω will therefore yield a maximum error of 40 μV . At the full-rated 2.0 MHz clock (CS5102A), the reference must supply a maximum load current of 5 μA peak-to-peak (0.5 μA typical). An output impedance of 2 Ω will therefore yield a maximum error of 10.0 μV . With a 4.5 V reference and LSB size of 138 μV this would ensure approximately 1/14 LSB accuracy. A 10 μF

capacitor exhibits an impedance of less than 2 Ω at frequencies greater than 16 kHz. A high-quality tantalum capacitor in parallel with a smaller ceramic capacitor is recommended.

Peaking in the reference's output impedance can occur because of capacitive loading at its output. Any peaking that might occur can be reduced by placing a small resistor in series with the capacitors. The equation in Figure 11 can be used to help calculate the optimum value of R for a particular reference. The term “ f_{peak} ” is the frequency of the peak in the output impedance of the reference before the resistor is added.

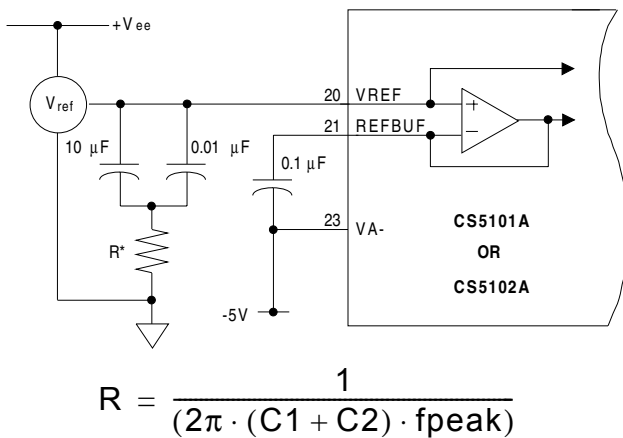

Figure 11. Reference Connections

The CS5101A and CS5102A can operate with a wide range of reference voltages, but signal-to-noise performance is maximized by using as wide a signal range as possible. The recommended reference voltage is 4.5 volts. The CS5101A and CS5102A can actually accept reference voltages up to the positive analog supply. However, the buffer's offset may increase as the reference voltage approaches VA+ thereby increasing external drive requirements at VREF. A 4.5V reference is the maximum reference voltage recommended. This allows 0.5V headroom for the internal reference buffer. Also, the buffer enlists the aid of an external 0.1 μF ceramic capacitor which must be tied between its output, REFBUF, and the negative analog supply, VA-. For more information on references, consult application note

[AN004, Voltage References for CS5012A / CS5014 / CS5016 / CS5101A / CS5102A / CS5126 Series of A/D Converters.](#)

6.2 Analog Input Connection

The analog input terminal functions similarly to the VREF input after each conversion when switching into the track mode. During the first six master clock cycles in the track mode, the buffered version of the analog input is used for coarse-charging the capacitor array. An additional period is required for fine-charging directly from AIN to obtain the specified accuracy. Figure 12 shows this operation. During coarse-charge the charge on the capacitor array first settles to the buffered version of the analog input. This voltage may be offset from the actual input voltage. During fine-charge, the charge then settles to the accurate unbuffered version.

Fine-charge settling is specified as a maximum of 1.125 μs (CS5101A) or 5.625 μs (CS5102A) for an analog source impedance of less than 50 Ω. In addition, the comparator requires a source impedance of less than 400 Ω around 2 MHz for stability. The source impedance can be effectively reduced at high frequencies by adding capacitance from AIN to ground (typically 200 pF). However, high DC source resistances will increase the input's RC time constant and extend the necessary acquisition time. For more information on input amplifiers, consult the application note,

[AN006, Buffer Amplifiers for CS5012A / 14 / 16 / CS5101A / CS5102A / CS5126 Series of A/D Converters.](#)

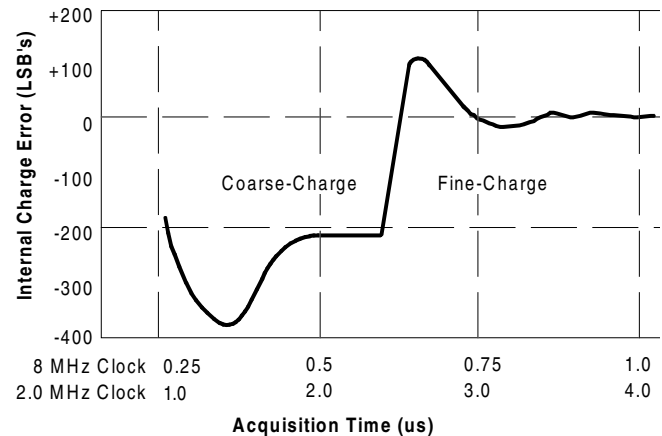

Figure 12. Charge Settling Time

6.3 Sleep Mode Operation

The CS5101A and CS5102A include a SLEEP pin. When SLEEP is active (low) each device will dissipate very low power to retain its calibration memo-

ry when the device is not sampling. It does not require calibration after SLEEP is made inactive (high). When coming out of Sleep mode, sampling can begin as soon as the oscillator starts (time will depend on the particular oscillator components) and the REFBUF capacitor is charged (which takes about 3 ms for the CS5101A, 50 ms for the CS5102A). To achieve minimum start-up time, use an external clock and leave the voltage reference powered-up. Connect a resistor (2 k Ω) between pins 20 and 21 to keep the REFBUF capacitor charged. Conversion can then begin as soon as the A/D circuitry has stabilized and performed a track cycle.

To retain calibration memory while SLEEP is active (low) VA+ and VD+ must be maintained at greater than 2.0V. VA- and VD- can be allowed to go to 0 volts. The voltages into VA- and VD- cannot just be “shut-off” as these pins cannot be allowed to float to potentials greater than AGND/DGND. If the supply voltages to VA- and VD- are removed, use a transistor switch to short these to the power supply ground while in Sleep mode.

6.4 Grounding & Power Supply Decoupling

The CS5101A and CS5102A use the analog ground connection, AGND, only as a reference voltage. No DC power currents flow through the AGND connection, and it is completely independent of DGND. However, any noise riding on the AGND input relative to the system's analog ground will induce conversion errors. Therefore, both the analog input and reference voltage should be referred to the AGND pin, which should be used as the entire system's analog ground reference.

The digital and analog supplies are isolated within the CS5101A and CS5102A and are pinned out separately to minimize coupling between the analog and digital sections of the chip. All four supplies should be decoupled to their respective grounds using 0.1 μ F ceramic capacitors. If significant low-frequency noise is present on the supplies, tantalum capacitors are recommended in parallel with the 0.1 μ F capacitors.

The positive digital power supply of the CS5101A and CS5102A must never exceed the positive analog supply by more than a diode drop or the CS5101A and CS5102A could experience permanent damage. If the two supplies are derived from separate sources, care must be taken that the analog supply comes up first at power-up. The system connection diagram (Figure 9) shows a decoupling scheme which allows the CS5101A and CS5102A to be powered from a single set of 5V rails. The positive digital supply is derived from the analog supply through a 10 Ω resistor to avoid the analog supply dropping below the digital supply. If this scheme is utilized, care must be taken to ensure that any digital load currents (which flow through the 10 Ω resistors) do not cause the magnitude of digital supplies to drop below the analog supplies by more than 0.5 volts. Digital supplies must always remain above the minimum specification.

As with any high-precision A/D converter, the CS5101A and CS5102A require careful attention to grounding and layout arrangements. However, no unique layout issues must be addressed to properly apply the devices.

7. CS5101A & CS5102A PERFORMANCE

7.1 Differential Nonlinearity

The self-calibration scheme utilized in the CS5101A and CS5102A features a calibration resolution of 1/4 LSB, or 18-bits. This ideally yields DNL of 1/4 LSB, with code widths ranging from 3/4 to 5/4 LSBs.

Traditional laser-trimmed ADCs have significant differential nonlinearities. Appearing as wide and narrow codes, DNL often causes entire sections of the transfer function to be missing. Although their affect is minor on $S/(N+D)$ with high amplitude signals, DNL errors dominate performance with low-level signals. For instance, a signal 80 dB below full-scale will slew past only 6 or 7 codes. Half of those codes could be missing with a conventional 16-bit ADC which achieves only 14-bit DNL.

The most common source of DNL errors in conventional ADCs is bit weight errors. These can arise due to accuracy limitations in factory trim stations, thermal or physical stresses after calibration, and/or drifts due to aging or temperature variations in the field. Bit-weight errors have a drastic effect on a converter's AC performance. They can be analyzed as step functions superimposed on the input signal. Since bits (and their errors) switch in and out throughout the transfer curve, their effect is signal dependent. That is, harmonic and intermodulation distortion, as well as noise, can vary with different input conditions.

Differential nonlinearities in successive-approximation ADCs also arise due to dynamic errors in the comparator. Such errors can dominate if the converter's throughput/sampling rate is too high. The comparator will not be allowed sufficient time to settle during each bit decision in the successive-approximation algorithm. The worst-case codes for dynamic errors are the major transitions (1/2 FS; 1/4, 3/4 FS; etc.). Since DNL effects are most crit-

ical with low-level signals, the codes around mid-scale (1/2 FS) are most important. Yet those codes are worst-case for dynamic DNL errors!

With all linearity calibration performed on-chip to 18-bits, the CS5101A and CS5102A maintain accurate bit weights. DNL errors are dominated by residual calibration errors of 1/4 LSB rather than dynamic errors in the comparator. Furthermore, all DNL effects on $S/(N+D)$ are buried by white broadband noise. (See Figures 19 and 21).

Figure 13 illustrates the DNL histogram plot of a typical CS5101A at 25 °C. Figure 14 illustrates the DNL of the CS5101A at 138 °C ambient after calibration at 25 °C ambient. Figure 15 and Figure 16 illustrate the DNL of the CS5102A at 25 °C and 138 °C ambient, respectively. A histogram test is a statistical method of deriving an A/D converter's differential nonlinearity. A ramp is input to the A/D and a large number of samples are taken to ensure a high confidence level in the test's result. The number of occurrences for each code is monitored and stored. A perfect A/D converter would have all codes of equal size and therefore equal numbers of occurrences. In the histogram test a code with the average number of occurrences will be considered ideal (DNL = 0). A code with more or less occurrences than average will appear as a DNL of greater or less than zero LSB. A missing code has zero occurrences, and will appear as a DNL of -1 LSB.

Figures 17 and 18 illustrate the code width distribution of the DNL plots shown in Figure 13 and Figure 15 respectively. The DNL error distribution plots indicate that the CS5101A and CS5102A calibrate the majority of their codes to tighter tolerance than the DNL plots in Figures 13 and 15 appear to indicate.

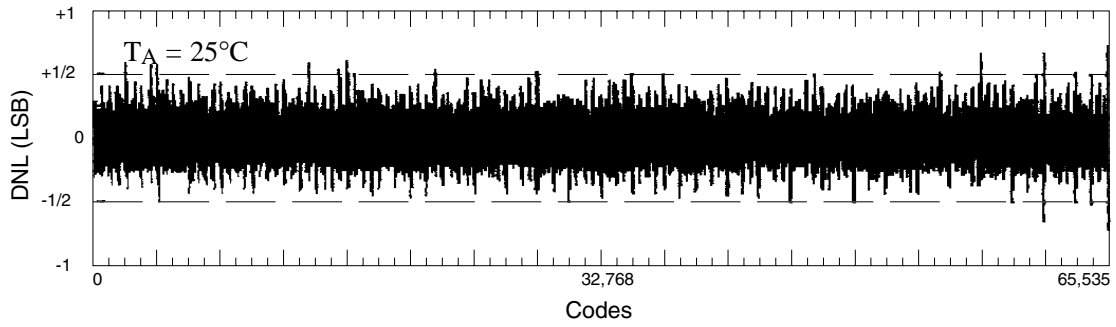

Figure 13. CS5101A DNL Plot - Ambient Temperature at 25 °C

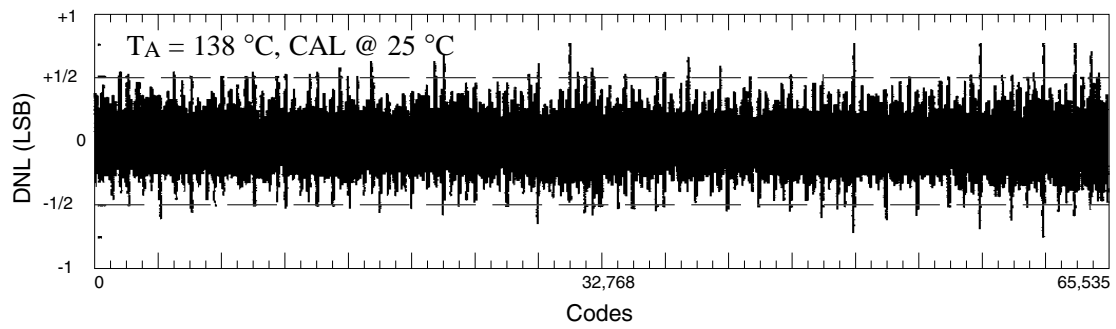

Figure 14. CS5101A DNL Plot - Ambient Temperature at 138 °C

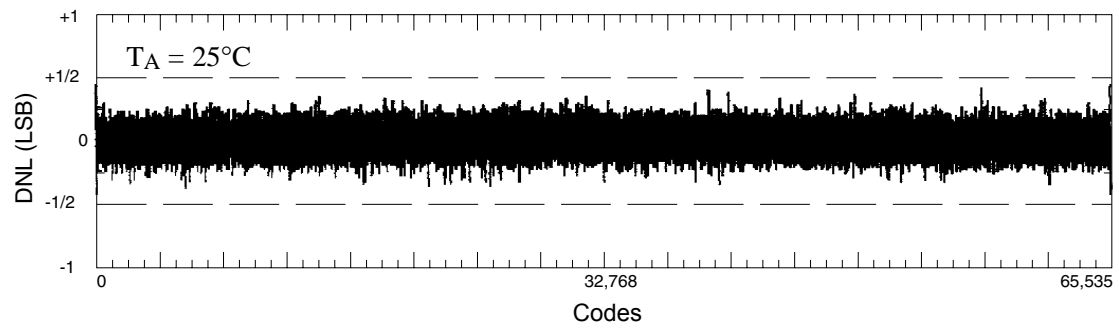

Figure 15. CS5102A DNL Plot - Ambient Temperature at 25 °C

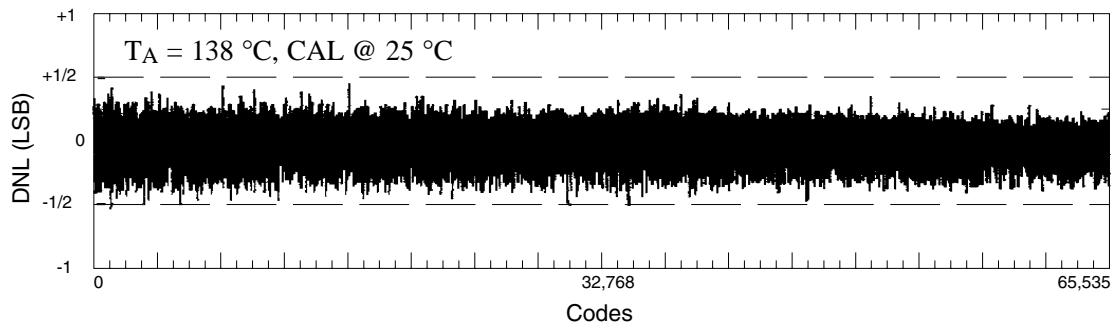

Figure 16. CS5102A DNL Plot - Ambient Temperature at 138 °C

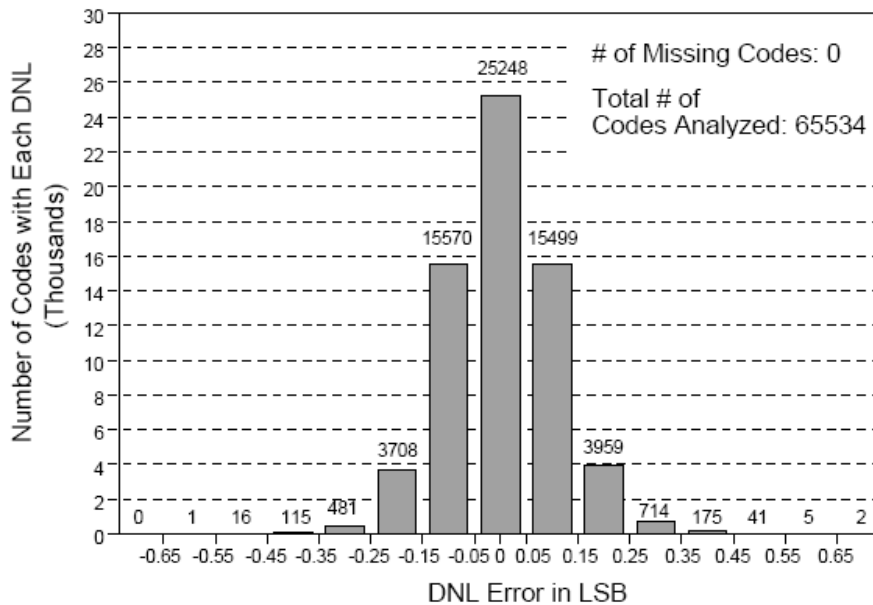

Figure 17. CS5101A DNL Error Distribution

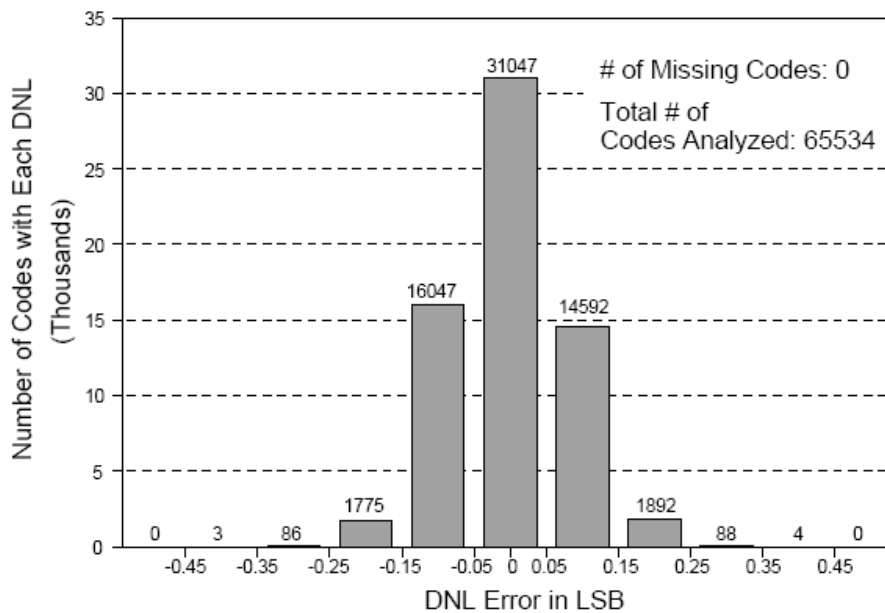
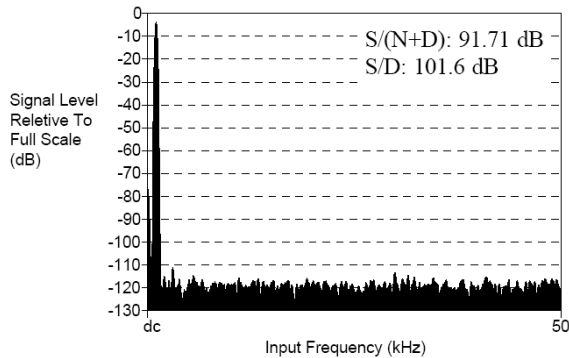
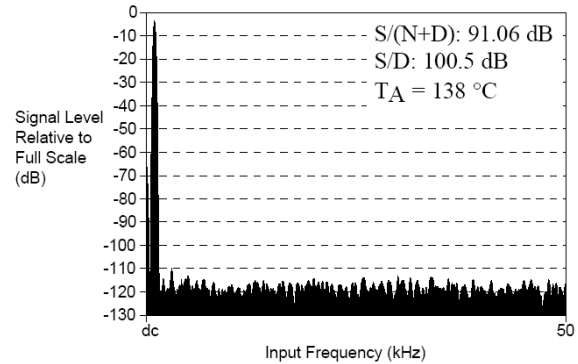
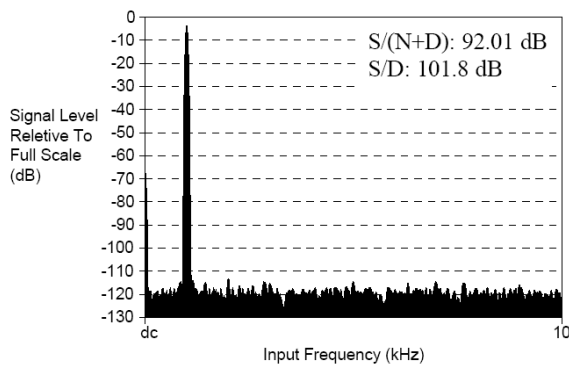
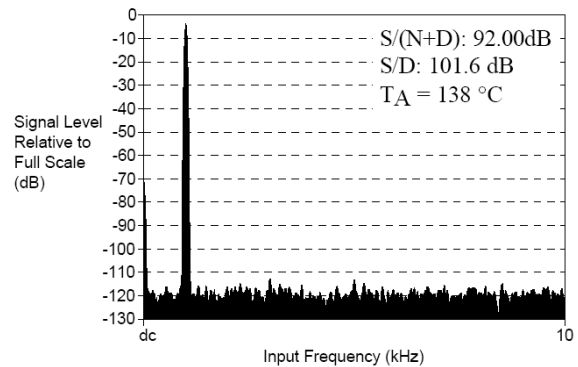

Figure 18. CS5102A DNL Error Distribution

7.2 FFT Tests and Windowing

In the factory, the CS5101A and CS5102A are tested using Fast Fourier Transform (FFT) techniques to analyze the converters' dynamic performance. A pure sine wave is applied to the device, and a "time record" of 1024 samples is captured and processed. The FFT algorithm analyzes the

spectral content of the digital waveform and distributes its energy among 512 "frequency bins." Assuming an ideal sine wave, distribution of energy in bins outside of the fundamental and DC can only be due to quantization effects and errors in the CS5101A and CS5102A.

Figure 19. CS5101A FFT (SSC Mode, 1-Channel)

Figure 20. CS5101A FFT (SSC Mode, 1-Channel)

Figure 21. CS5102A FFT (SSC Mode, 1-Channel)

Figure 22. CS5102A FFT (SSC Mode, 1-Channel)

If sampling is not synchronized to the input sine wave, it is highly unlikely that the time record will contain an integer number of periods of the input signal. However, the FFT assumes that the signal is periodic, and will calculate the spectrum of a signal that appears to have large discontinuities, thereby yielding a severely distorted spectrum. To avoid this problem, the time record is multiplied by a window function prior to performing the FFT. The window function smoothly forces the endpoints of the time record to zero, thereby removing the discontinuities.

The effect of the window in the frequency-domain is to convolute the spectrum of the window with that of the actual input.

The quality of the window used for harmonic analysis is typically judged by its highest side-lobe level. A five term window is used in FFT testing of the CS5101A and CS5102A. This windowing algo-

rithm attenuates the side-lobes to below the noise floor. Artifacts of windowing are discarded from the signal-to-noise calculation using the assumption that quantization noise is white. Averaging the FFT results from ten time records filters the spectral variability that can arise from capturing finite time records without disturbing the total energy outside the fundamental. All harmonics are visible in the plots.

As illustrated in Figure 19, the CS5101A typically provides about 92 dB S/(N+D) and 0.001% THD at 25 °C. Figure 20 illustrates only minor degradation in performance when the ambient temperature is raised to 138 °C. Figures 21 and 22 illustrate that the CS5102A typically yields 92 dB S/(N+D) and 0.001% THD even with a large change in ambient temperature. Unlike conventional successive-approximation ADC's, the signal-to-noise and dynamic range of the CS5101A and CS5102A are

not limited by differential nonlinearities (DNL) caused by calibration errors. Rather, the dominant noise source is broadband thermal noise which aliases into the baseband. This white broadband noise also appears as an idle channel noise of 1/2 LSB (rms).

7.3 Sampling Distortion

Like most discrete sample/hold amplifier designs, the inherent sample/hold of the CS5101A and CS5102A exhibits a frequency-dependent distortion due to non-ideal sampling of the analog input voltage. The calibrated capacitor array used during conversions is also used to track and hold the analog input signal. The conversion is not performed on the analog input voltage per se, but is actually performed on the charge trapped on the capacitor array at the moment the HOLD command is given. The charge on the array ideally assumes a linear relationship to the analog input voltage. Any deviation from this linear relationship will result in con-

version errors even if the conversion process proceeds flawlessly.

At DC, the DAC capacitor array's voltage coefficient dictates the converter's linearity. This variation in capacitance with respect to applied signal voltage yields a nonlinear relationship between the charge on the array and the analog input voltage and places a bow or wave in the transfer function. This is the dominant source of distortion at low input frequencies (Figures 19, 20, 21, and 22).

The ideal relationship between the charge on the array and the input voltage can also be distorted at high signal frequencies due to nonlinearities in the internal MOS switches. Dynamic signals cause ac current to flow through the switches connecting the capacitor array to the analog input pin in the track mode. Nonlinear on-resistance in the switches causes a nonlinear voltage drop. This effect worsens with increased signal frequency and slew rate. This distortion is negligible at signal levels below -10 dB of full scale.

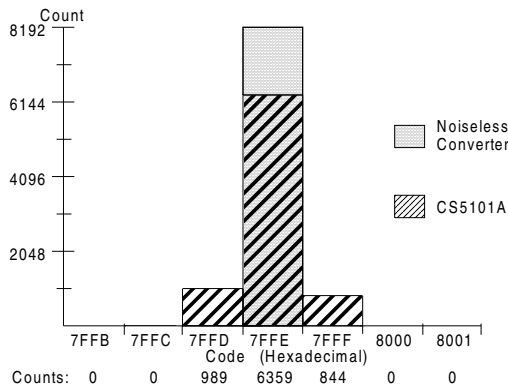

Figure 23. CS5101A Histogram Plot of 8192 Conversion Inputs

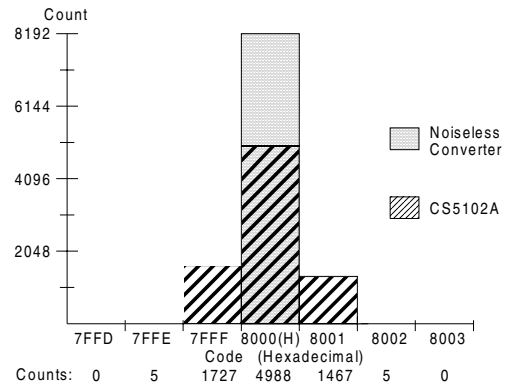

Figure 24. CS5102A Histogram Plot of 8192 Conversion Inputs

7.4 Noise

An A/D converter's noise can be described like that of any other analog component. However, the converter's output is in digital form so any filtering of its noise must be performed in the digital domain. Digitized samples of analog inputs are often considered individual, static snap-shots in time with no uncertainty or noise. In reality, the result of each conversion depends on the analog input level and the instantaneous value of noise sources in the ADC. If sequential samples from the ADC are treated as a "waveform", simple filtering can be implemented in software to improve noise performance with minimal processing overhead.

All analog circuitry in the CS5101A and CS5102A is wideband in order to achieve fast conversions and high throughput. Wideband noise in the CS5101A and CS5102A integrates to 35 μV rms in unipolar mode (70 μV rms in bipolar mode). This is approximately 1/2 LSB rms with a 4.5V reference in both modes. Figure 23 shows a histogram plot of output code occurrences obtained from 8192 samples taken from a CS5101A in the bipolar mode. Hexadecimal code 7FFE was arbitrarily selected and the analog input was set close to code center. With a noiseless converter, code 7FFE would always appear. The histogram plot of the device has a "bell" shape with all codes other than 7FFE due to internal noise. Figure 24 illustrates the noise histogram of the CS5102A.

In a sampled data system all information about the analog input applied to the sample/hold appears in the baseband from DC to one-half the sampling rate. This includes high-frequency components which alias into the baseband. Low-pass (anti-alias) filters are therefore used to remove frequency components in the input signal which are above one-half the sample rate. However, all wideband noise introduced by the CS5101A and CS5102A still aliases into the baseband. This "white" noise is evenly spread from DC to one-half the sampling rate and integrates to 35 μV rms in unipolar mode.

Noise in the digital domain can be reduced by sampling at higher than the desired word rate and averaging multiple samples for each word. Oversampling spreads the device's noise over a wider band (for lower noise density), and averaging applies a low-pass response which filters noise above the desired signal bandwidth. In general, the device's noise performance can be maximized in any application by always sampling at the maximum specified rate of 100 kSps (CS5101A) or 20 kSps (CS5102A) (for lowest noise density) and digitally filtering to the desired signal bandwidth.

7.5 Aperture Jitter

Track-and-hold amplifiers commonly exhibit two types of aperture jitter. The first, more appropriately termed "aperture window", is an input-voltage-dependent variation in the aperture delay. Its signal dependency causes distortion at high frequen-

cies. The proprietary architecture of the CS5101A and CS5102A avoids applying the input voltage across a sampling switch, thus avoiding any “aperture window” effects. The second type of aperture jitter, due to component noise, assumes a random

nature. With only 100 ps peak-to-peak aperture jitter, the CS5101A and CS5102A can process full-scale signals up to 1/2 the throughput frequency without significant errors due to aperture jitter.

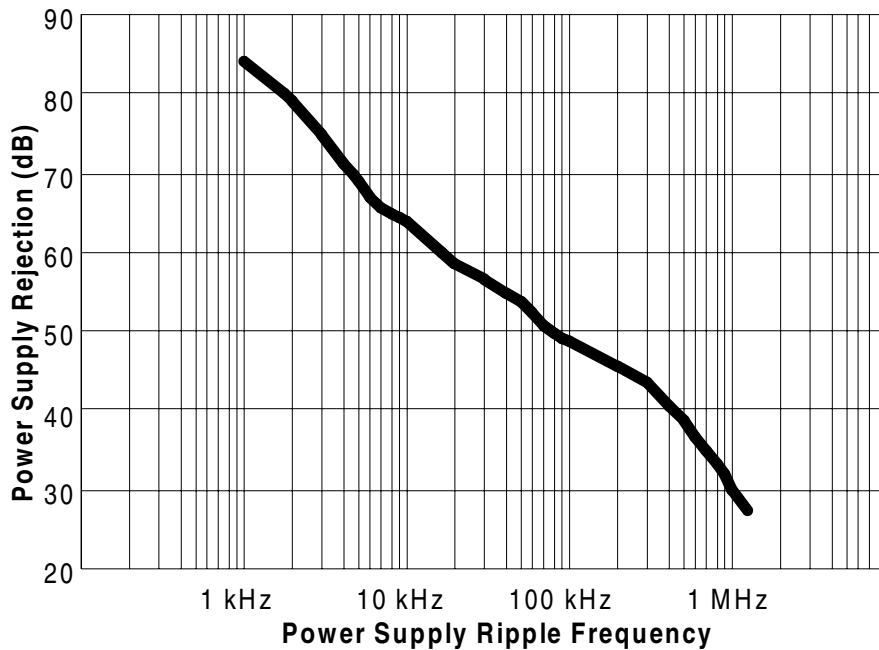

Figure 25. Power Supply Rejection

7.6 Power Supply Rejection

The power supply rejection performance of the CS5101A and CS5102A is enhanced by the on-chip self-calibration and an “auto-zero” process. Drifts in power supply voltages at frequencies less than the calibration rate have negligible effect on the device's accuracy. This is because the CS5101A and CS5102A adjust their offset to within a small fraction of an LSB during calibration. Above the calibration frequency the excellent power sup-

ply rejection of the internal amplifiers is augmented by an auto-zero process. Any offsets are stored on the capacitor array and are effectively subtracted once conversion is initiated. Figure 25 shows power supply rejection of the CS5101A and CS5102A in the bipolar mode with the analog input grounded and a 300 mV p-p ripple applied to each supply. Power supply rejection improves by 6 dB in the unipolar mode.

8. PIN DESCRIPTIONS

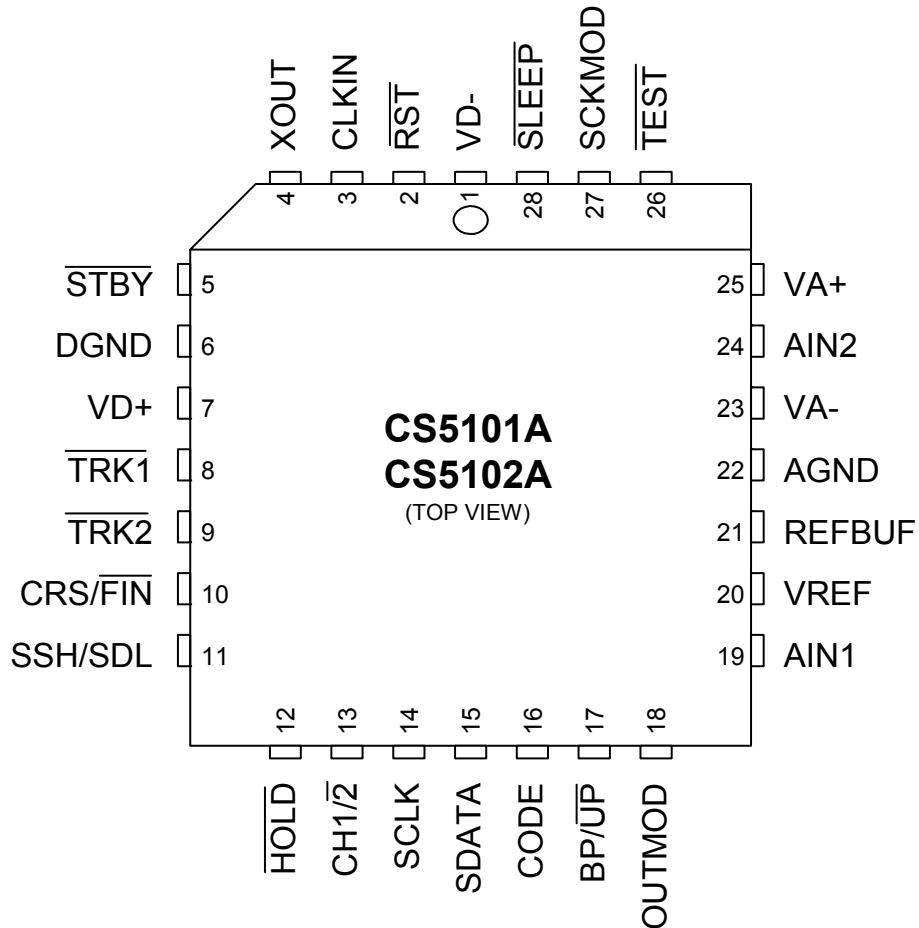

Figure 26. CS5101A & CS5102A 28-pin PLCC Pinout

8.1 Power Supply Connections

VD+ - Positive Digital Power, PIN 7

Positive digital power supply. Nominally +5 volts.

VD- - Negative Digital Power, PIN 1.

Negative digital power supply. Nominally -5 volts.

DGND - Digital Ground, PIN 6.

Digital ground [reference].

VA+ - Positive Analog Power, PIN 25.

Positive analog power supply. Nominally +5 volts.

VA- - Negative Analog Power, PIN 23.

Negative analog power supply. Nominally -5 volts.

AGND - Analog Ground, PIN 22.

Analog ground reference.

8.2 Oscillator

CLKIN - Clock Input, PIN 3.

All conversions and calibrations are timed from a master clock which can be externally supplied by driving CLKIN [this input TTL-compatible, CMOS recommended].

XOUT - Crystal Output, PIN 4.

The master clock can be generated by tying a crystal across the CLKIN and XOUT pins. If an external clock is used, XOUT must be left floating.

8.3 Digital Inputs

HOLD - Hold, PIN 12.

A falling transition on this pin sets the CS5101A or CS5102A to the hold state and initiates a conversion. This input must remain low for at least $1/t_{clk} + 20$ ns. When operating in Free Run Mode, HOLD is disabled, and should be tied to DGND or VD+.

CRS/FIN - Coarse Charge/Fine Charge Control, PIN 10.

When brought high during acquisition time, CRS/FIN forces the CS5101A or CS5102A into coarse charge state. This engages the internal buffer amplifier to track the analog input and charges the capacitor array much faster, thereby allowing the CS5101A or CS5102A to track high-slewing signals. In order to get an accurate sample, the last coarse charge period before initiating a conversion (bringing HOLD low) must be longer than $0.75\mu\text{s}$ (CS5101A) or $3.75\mu\text{s}$ (CS5102A). Similarly, the fine charge period immediately prior to conversion must be at least $1.125\mu\text{s}$ (CS5101A) or $5.625\mu\text{s}$ (CS5102A). The CRS/FIN pin must be low during conversion time. For normal operation, CRS/FIN should be tied low, in which case the CS5101A or CS5102A will automatically enter coarse charge for 6 clock cycles immediately after the end of conversion.

CH1/2 - Left/Right Input Channel Select, PIN 13.

Status at the end of a conversion cycle determines which analog input channel will be acquired for the next conversion cycle. When in Free Run Mode, CH1/2 is an output, and will indicate which channel is being sampled during the current acquisition phase.

SLEEP - Sleep, PIN 28.

When brought low causes the CS5101A or CS5102A to enter a power-down state. All calibration coefficients are retained in memory, so no recalibration is needed after returning to the normal operating mode. If using the internal crystal oscillator, time must be allowed after SLEEP returns high for the crystal oscillator to stabilize. SLEEP should be tied high for normal operation.

CODE - 2's Complement/Binary Coding Select, PIN 16.

Determines whether output data appears in 2's complement or binary format. If high, 2's complement; if low, binary.

BP/UP - Bipolar/Unipolar Input Range Select, PIN 17.

When low, the CS5101A or CS5102A accepts a unipolar input range from AGND to VREF. When high, the CS5101A or CS5102A accepts bipolar inputs from -VREF to +VREF.

SCKMOD - Serial Clock Mode Select, PIN 27.

When high, the SCLK pin is an input; when low, it is an output. Used in conjunction with OUTMOD to select one of 4 output modes described in Table 2.

OUTMOD - Output Mode Select, PIN 18.

The status of SCKMOD and OUTMOD determine which of four output modes is utilized. The four modes are described in Table 2.

SCLK - Serial Clock, PIN 14.

Serial data changes status on a falling edge of this input, and is valid on a rising edge. When SCKMOD is high SCLK acts as an input. When SCKMOD is low the CS5101A or CS5102A generates its own serial clock at $\frac{1}{4}$ the master clock frequency and SCLK is an output.

 $\overline{\text{RST}}$ - Reset, PIN 2.

When taken low, all internal digital logic is reset. Upon returning high, a full calibration sequence is initiated which takes 11,528,160 $\overline{\text{CLKIN}}$ cycles (CS5101A) or 2,882,040 $\overline{\text{CLKIN}}$ cycles (CS5102A) to complete. During calibration, the $\overline{\text{HOLD}}$ input will be ignored. The CS5101A or CS5102A must be reset at power-up for calibration, however; calibration is maintained during SLEEP mode, and need not be repeated when resuming normal operation.

8.4 Analog Inputs

 AIN1 , AIN2 - Channel 1 and 2 Analog Inputs, PINS 19 and 24.

Analog input connections for the left and right input channels.

 VREF - Voltage Reference, PIN 20.

The analog reference voltage which sets the analog input range. In unipolar mode VREF sets full-scale; in bipolar mode its magnitude sets both positive and negative full-scale.

8.5 Digital Outputs

 $\overline{\text{STBY}}$ - Standby (Calibrating), PIN 5.

Indicates calibration status after reset. Remains low throughout the calibration sequence and returns high upon completion.

 SDATA - Serial Output, PIN 15.

Presents each output data bit on a falling edge of SCLK. Data is valid to be latched on the rising edge of SCLK.

 SSH/SDL - Simultaneous Sample/Hold / Serial Data Latch, PIN 11.

Used to control an external sample/hold amplifier to achieve simultaneous sampling between channels. In FRN and SSC modes (SCLK is an output), this signal provides a convenient latch signal which forms the 16 data bits. This can be used to control external serial to parallel latches, or to control the serial port in a DSP.

 $\overline{\text{TRK1}}$, $\overline{\text{TRK2}}$ - Tracking Channel 1, Tracking Channel 2, PINS 8 and 9.

Falls low at the end of a conversion cycle, indicating the acquisition phase for the corresponding channel. The $\overline{\text{TRK1}}$ or $\overline{\text{TRK2}}$ pin will return high at the beginning of conversion for that channel.

8.6 Analog Outputs

 REFBUF - Reference Buffer Output, PIN 21.

Reference buffer output.

8.7 Miscellaneous

 $\overline{\text{TEST}}$ - Test, PIN 26.

Allows access to the CS5101A's and the CS5102A's test functions which are reserved for factory use. Must be tied to VD+.

9. PARAMETER DEFINITIONS

Linearity Error

The deviation of a code from a straight line passing through the endpoints of the transfer function after zero- and full-scale errors have been accounted for. “Zero-scale” is a point 1/2 LSB below the first code transition and “full-scale” is a point 1/2 LSB beyond the code transition to all ones. The deviation is measured from the middle of each particular code. Units in % Full-Scale.

Differential Linearity

Minimum resolution for which no missing codes is guaranteed. Units in bits.

Full-scale Error

The deviation of the last code transition from the ideal ($V_{REF}-3/2$ LSBs). Units in LSBs.

Unipolar Offset

The deviation of the first code transition from the ideal (1/2 LSB above AGND) when in unipolar mode (BP/UP low). Units in LSBs.

Bipolar Offset

The deviation of the mid-scale transition (011...111 to 100...000) from the ideal (1/2 LSB below AGND) when in bipolar mode (BP/UP high). Units in LSBs.

Bipolar Negative Full-scale Error

The deviation of the first code transition from the ideal when in bipolar mode (BP/UP high). The ideal is defined as lying on a straight line which passes through the final and mid-scale code transitions. Units in LSBs.

Signal-to-peak Harmonic or Noise

The ratio of the rms value of the signal to the rms value of the next largest spectral component below the Nyquist rate (excepting DC). This component is often an aliased harmonic when the signal frequency is a significant proportion of the sampling rate. Expressed in decibels.

Total Harmonic Distortion

The ratio of the rms sum of all harmonics to the rms value of the signal. Units in percent.

Signal-to-(Noise + Distortion)

The ratio of the rms value of the signal to the rms sum of all other spectral components below the Nyquist rate (excepting DC), including distortion components. Expressed in decibels.

Aperture Time

The time required after the hold command for the sampling switch to open fully. Effectively a sampling delay which can be nulled by advancing the sampling signal. Units in nanoseconds.

Aperture Jitter

The range of variation in the aperture time. Effectively the “sampling window” which ultimately dictates the maximum input signal slew rate acceptable for a given accuracy. Units in picoseconds.

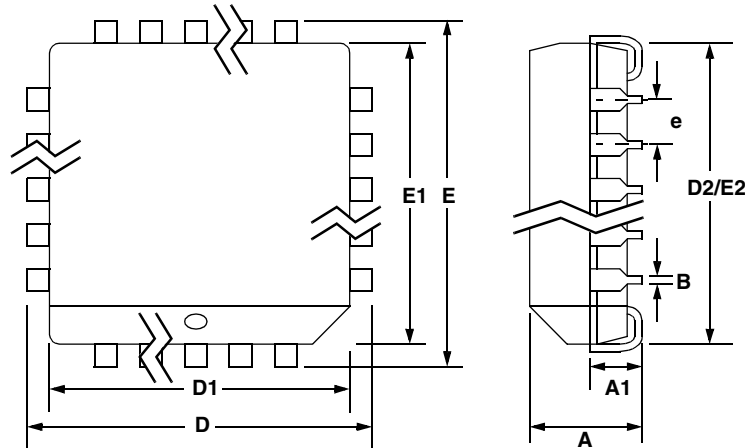
10. PACKAGE DIMENSIONS
28L PLCC PACKAGE DRAWING

| DIM | INCHES | | | MILLIMETERS | | |
|-----|--------|--------|-------|-------------|--------|--------|
| | MIN | NOM | MAX | MIN | NOM | MAX |
| A | 0.165 | 0.1725 | 0.180 | 4.191 | 4.3815 | 4.572 |
| A1 | 0.090 | 0.105 | 0.120 | 2.286 | 2.667 | 3.048 |
| B | 0.013 | 0.017 | 0.021 | 0.3302 | 0.4318 | 0.533 |
| D | 0.485 | 0.490 | 0.495 | 12.319 | 12.446 | 12.573 |
| D1 | 0.450 | 0.453 | 0.456 | 11.430 | 11.506 | 11.582 |
| D2 | 0.390 | 0.410 | 0.430 | 9.906 | 10.414 | 10.922 |
| E | 0.485 | 0.490 | 0.495 | 12.319 | 12.446 | 12.573 |
| E1 | 0.450 | 0.453 | 0.456 | 11.430 | 11.506 | 11.582 |
| E2 | 0.390 | 0.410 | 0.430 | 9.906 | 10.414 | 10.922 |
| e | 0.040 | 0.050 | 0.060 | 1.016 | 1.270 | 1.524 |

JEDEC # : MS-047 AA-AF

Controlling Dimension is Inches

Figure 27. 28-Pin PLCC Mechanical Drawing

11. ORDERING INFORMATION

| Model | Linearity | Temperature | Conversion Time | Throughput | Package |
|--------------------------|-----------|---------------|-----------------|------------|-------------|
| CS5101A-JL8 | 0.003 | 0 to +70 °C | 8.13 μ s | 100 kSps | 28-pin PLCC |
| CS5101A-JL8Z (lead free) | | | | | |
| CS5101A-BL8 | 0.002 | -40 to +85 °C | | | |
| CS5101A-BL8Z (lead free) | | | | | |
| CS5102A-JL | 0.003 | 0 to +70 °C | 40 μ s | 20 kSps | |
| CS5102A-JLZ (lead free) | | | | | |
| CS5102A-BL | 0.0015 | -40 to +85 °C | | | |
| CS5102A-BLZ (lead free) | | | | | |

12. ENVIRONMENTAL, MANUFACTURING, & HANDLING INFORMATION

| Model Number | Peak Reflow Temp | MSL Rating* | Max Floor Life |
|--------------------------|------------------|-------------|----------------|
| CS5101A-JL8 | 225 °C | 2 | 365 Days |
| CS5101A-JL8Z (lead free) | 260 °C | | |
| CS5101A-BL8 | 225 °C | | |
| CS5101A-BL8Z (lead free) | 260 °C | | |
| CS5102A-JL | 225 °C | | |
| CS5102A-JLZ (lead free) | 260 °C | | |
| CS5102A-BL | 225 °C | | |
| CS5102A-BLZ (lead free) | 260 °C | | |

* MSL (Moisture Sensitivity Level) as specified by IPC/JEDEC J-STD-020.

13. REVISIONS

| Revision | Date | Changes |
|----------|----------------|---|
| F1 | September 2004 | Initial Release |
| F2 | October 2004 | Corrected table heading on Page 6. |
| F3 | June 2005 | Minor edits, added lead-free device ordering information |
| F4 | July 2005 | removed obsolete packages, corrected lead-free device information |
| F5 | August 2005 | Added MSL, reflow temp, & floor life specifications. |
| F6 | January 2006 | Corrected <i>Linearity Error</i> mislabeled in <i>Characteristics & Specifications</i> as “Differential Input Range”. |

Contacting Cirrus Logic Support

For all product questions and inquiries contact a Cirrus Logic Sales Representative.

To find the one nearest to you go to www.cirrus.com

IMPORTANT NOTICE

Cirrus Logic, Inc. and its subsidiaries (“Cirrus”) believe that the information contained in this document is accurate and reliable. However, the information is subject to change without notice and is provided “AS IS” without warranty of any kind (express or implied). Customers are advised to obtain the latest version of relevant information to verify, before placing orders, that information being relied on is current and complete. All products are sold subject to the terms and conditions of sale supplied at the time of order acknowledgment, including those pertaining to warranty, indemnification, and limitation of liability. No responsibility is assumed by Cirrus for the use of this information, including use of this information as the basis for manufacture or sale of any items, or for infringement of patents or other rights of third parties. This document is the property of Cirrus and by furnishing this information, Cirrus grants no license, express or implied under any patents, mask work rights, copyrights, trademarks, trade secrets or other intellectual property rights. Cirrus owns the copyrights associated with the information contained herein and gives consent for copies to be made of the information only for use within your organization with respect to Cirrus integrated circuits or other products of Cirrus. This consent does not extend to other copying such as copying for general distribution, advertising or promotional purposes, or for creating any work for resale.

CERTAIN APPLICATIONS USING SEMICONDUCTOR PRODUCTS MAY INVOLVE POTENTIAL RISKS OF DEATH, PERSONAL INJURY, OR SEVERE PROPERTY OR ENVIRONMENTAL DAMAGE (“CRITICAL APPLICATIONS”). CIRRUS PRODUCTS ARE NOT DESIGNED, AUTHORIZED OR WARRANTED FOR USE IN AIRCRAFT SYSTEMS, MILITARY APPLICATIONS, PRODUCTS SURGICALLY IMPLANTED INTO THE BODY, AUTOMOTIVE SAFETY OR SECURITY DEVICES, LIFE SUPPORT PRODUCTS OR OTHER CRITICAL APPLICATIONS. INCLUSION OF CIRRUS PRODUCTS IN SUCH APPLICATIONS IS UNDERSTOOD TO BE FULLY AT THE CUSTOMER'S RISK AND CIRRUS DISCLAIMS AND MAKES NO WARRANTY, EXPRESS, STATUTORY OR IMPLIED, INCLUDING THE IMPLIED WARRANTIES OF MERCHANTABILITY AND FITNESS FOR PARTICULAR PURPOSE, WITH REGARD TO ANY CIRRUS PRODUCT THAT IS USED IN SUCH MANNER. IF THE CUSTOMER OR CUSTOMER'S CUSTOMER USES OR PERMITS THE USE OF CIRRUS PRODUCTS IN CRITICAL APPLICATIONS, CUSTOMER AGREES, BY SUCH USE, TO FULLY INDEMNIFY CIRRUS, ITS OFFICERS, DIRECTORS, EMPLOYEES, DISTRIBUTORS AND OTHER AGENTS FROM ANY AND ALL LIABILITY, INCLUDING ATTORNEYS' FEES AND COSTS, THAT MAY RESULT FROM OR ARISE IN CONNECTION WITH THESE USES.

Cirrus Logic, Cirrus, and the Cirrus Logic logo designs are trademarks of Cirrus Logic, Inc. All other brand and product names in this document may be trademarks or service marks of their respective owners.

Looking for pricing, stock, or lifecycle information?

Click below to explore more details on WIN SOURCE:

 [View CS5101A-JL8Z on WIN SOURCE](#)

 [Cirrus Logic Inc. Information](#)

Optimize Your Supply Chain with WIN SOURCE Solutions

-  Global Sourcing Solution
-  Obsolete Management
-  Cost Control Management
-  Shortage Management
-  Alternative Solution
-  Excess Inventory Management