

16-bit & 20-bit Bridge Transducer A/D Converters

Features

- On-chip Instrumentation Amplifier
- On-chip Programmable Gain Amplifier
- On-Chip 4-Bit D/A For Offset Removal
- Dynamic Excitation Options
- Linearity Error: $\pm 0.0015\%$ FS
 - 20-bit, No Missing Codes
- CMRR at 50/60 Hz > 200 dB
- System Calibration Capability with calibration read/write option
- 3-, 4-, or 5-wire Serial Communications Port
- Low Power Consumption: 40 mW
 - 10 μ W Standby Mode for Portable applications

Description

The CS5516 and CS5520 are complete solutions for digitizing low level signals from strain gauges, load cells, and pressure transducers. Any family of mV output transducers, including those requiring bridge excitation, can be interfaced directly to the CS5516 or CS5520. The devices offer an on-chip software programmable instrumentation amplifier block, choice of DC or AC bridge excitation, and software selectable reference and signal demodulation.

The CS5516 uses delta-sigma modulation to achieve 16-bit resolution at output word rates up to 60 Sps. The CS5520 achieves 20-bit resolution at output word rates up to 60 Sps.

The CS5516 and CS5520 sample at a rate set by the user in the form of either an external CMOS clock or a crystal. On-chip digital filtering provides rejection of all frequencies above 12 Hz for a 4.096 MHz clock.

The CS5516 and CS5520 include system calibration to null offset and gain errors in the input channel. The digital values associated with the system calibration can be written to, or read from, the calibration RAM locations at any time via the serial communications port. The 4-bit DC offset D/A converter, in conjunction with digital correction, is initially used to zero the input offset value.

ORDERING INFORMATION

See [page 29](#).

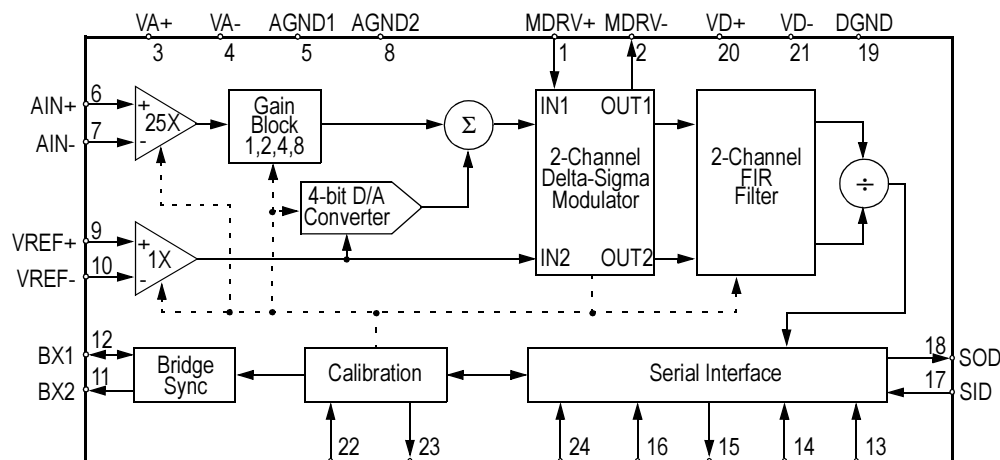

ANALOG CHARACTERISTICS (continued)

Parameter*	Min	Typ	Max	Units	
Specified Temperature Range	-40 to +85			°C	
Accuracy					
Linearity Error	-	0.0007	0.0015	±%FS	
Differential Nonlinearity (No Missing Codes)	20	-	-	Bits	
Unipolar Gain Error (Note 2)	-	±4	±24	ppm	
Bipolar Gain Error (Note 2)	-	±4	±24	ppm	
Unipolar/Bipolar Gain Drift	-	±1	-	ppm/°C	
Unipolar Offset (Note 2)	-	±4	±8	LSB ₂₀	
Bipolar Offset (Note 2)	-	±4	±8	LSB ₂₀	
Offset Drift	-	±0.005	-	µV/°C	
Noise (Referred to Input)	Gain = 25 (25 x 1)	-	250	-	nVrms
	Gain = 50 (25 x 2)	-	200	-	nVrms
	Gain = 100 (25 x 4)	-	150	-	nVrms
	Gain = 200 (25 x 8)	-	150	-	nVrms

µV	Unipolar Mode			Bipolar Mode		
	LSB's	% FS	ppm FS	LSB's	% FS	ppm FS
0.025	0.26	0.0000238	0.25	0.13	0.0000119	0.125
0.047	0.50	0.0000477	0.50	0.26	0.0000238	0.25
0.095	1.00	0.0000954	1.0	0.50	0.0000477	0.50
0.190	2.00	0.0001907	2.0	1.00	0.0000954	1.0
0.380	4.00	0.0003814	4.0	2.00	0.0001907	2.0

VREF = 2.5V

PGA gain = 1

CS5520; 20-Bit Unit Conversion Factors

* Refer to the Specification Definitions immediately following the Pin Description Section.

Specifications are subject to change without notice.

ANALOG CHARACTERISTICS (continued)

Parameter		Min	Typ	Max	Units
Specified Temperature Range		-40 to +85			°C
Analog Input					
Analog Input Range	Unipolar Bipolar	12.5, 25, 50, 100 ±12.5, ±25, ±50, ±100			mV mV
Common Mode Rejection	dc	-	165	-	dB
	50, 60 Hz	-	200	-	dB
Input Capacitance		-	5	-	pF
Input Bias Current	(Note 1)	-	100	-	pA
Instrumentation Amplifier					
Gain		-	25	-	
Bandwidth		-	200	-	kHz
Unity Gain Bandwidth		-	5	-	MHz
Output Slew Rate		-	1.5	-	V/μsec
Noise @ 10 Hz BW		-	100	-	nVrms
Power Supply Rejection @ 50/60 Hz	(Note 3)	-	120	-	dB
Common Mode Range	(Note 4)	-	±3	-	V
Chopping Frequency		-	XIN/128	-	Hz
Programmable Gain Amplifier					
Gain Tracking	(Note 5)	-	±1	-	%
4-Bit Offset Trim DAC					
Accuracy		-	±5	-	%
Voltage Reference Input					
Range	(Note 6)	2.0	2.5	3.8	V
Common Mode Rejection:	dc	-	60	-	dB
	50, 60 Hz	-	200	-	
Input Capacitance		-	15	-	pF
Input Bias Current	(Note 1)	-	10	-	nA

Notes: 3. This includes the on-chip digital filtering.

4. The maximum magnitude of the differential input voltage, $V_{diff(in)}$ is determined by the following:
 $V_{diff(in)} < 300 \text{ mV} - |V_{cm}/12.5|$ and should never exceed 300mV.

V_{cm} is the common mode voltage which is applied to the instrumentation amplifier inputs.

The above equation should be used to calculate the allowable common mode voltage for a given differential voltage applied to the first gain stage inputs. This limit ensures that the instrumentation amplifier does not saturate.

5. Gain tracking accuracy can be significantly improved by uploading a calibrated gain word to the gain register for each PGA gain selection.

6. The common mode voltage on the Voltage Reference Input, plus the reference range, $[(V_{REF+}) - (V_{REF-})]/2$, must not exceed ±3 volts.

ANALOG CHARACTERISTICS (continued)

Parameter	Min	Typ	Max	Units	
Modulator Differential Voltage Reference					
Nominal Output Voltage	-	3.75	-	V	
Initial Output Voltage Tolerance	-	±100	-	mV	
Temperature Coefficient	-	100	-	ppm/°C	
Line Regulation (4.75V < V _A < 5.25V)	-	0.5	-	mV/V	
Output Voltage Noise 0.1 to 15 Hz	-	10	-	μV _{p-p}	
Output Current Drive: Source Current	-	-	20	μA	
Sink Current	-	-	20	μA	
Power Supplies					
DC Power Supply Currents	I _{A+}	-	2.7	3.5	mA
	I _{A-}	-	-2.7	-3.5	mA
	I _{D+}	-	1.5	2.2	mA
	I _{D-}	-	-0.6	-0.8	mA
Power Dissipation: (Note 7)	Normal Operation	-	37.5	-	mW
	Standby Mode	-	10	-	μW
Power Supply Rejection:	dc Positive Supplies	-	100	-	dB
	dc Negative Supplies	-	95	-	dB
System Calibration Specifications					
Positive Full Scale Calibration Range (Note 8)	Unipolar Mode	0.8T	-	1.2T	V
	Bipolar Mode	0.8T	-	1.2T	V
Maximum Ratiometric Offset Calibration Range (Note 8)	Unipolar Mode	-2T	-	+2T	V
	Bipolar Mode	-2T	-	+2T	V
Differential Input Voltage Range (Notes 4, 8, 9, 10)	Unipolar Mode	V _{offset} + (1.2T)		V	
	Bipolar	V _{offset} ± (1.2T)		V	

Notes: 7. All outputs unloaded. All inputs CMOS levels.

8. $T = V_{REF} / (G \times 25)$, where T is the full scale span, where V_{REF} is the differential voltage across V_{REF+} and V_{REF-} in volts, and G is the gain setting of the second gain block. G can be set to 1, 2, 4, 8. This sets the overall gain to 25, 50, 100, 200. The gain can then be fine tuned by using the calibration of the full scale point.

9. When calibrated.

10. V_{offset} is the offset corrected by the offset calibration routine. V_{offset} may be as large as 2T.

DYNAMIC CHARACTERISTICS

Parameter	Symbol	Ratio	Units
AIN and VREF Input Sampling Frequency	f_{is}	$f_{clk}/128$	Hz
Modulator Sampling Frequency	f_s	$f_{clk}/256$	Hz
Output Update Rate	f_{out}	$f_{clk}/81,920$	Sps
Filter Corner Frequency	f_{-3dB}	$f_{clk}/341,334$	Hz
Settling Time to $\pm 0.0007\%$ (FS Step)	t_s	$6/f_{out}$	s

DIGITAL CHARACTERISTICS ($T_A = T_{MIN}$ to T_{MAX} ; V_{A+} , $V_{D+} = 5V \pm 5\%$; V_{A-} , $V_{D-} = -5V \pm 5\%$; $DGND = 0$) All measurements below are performed under static conditions.

Parameter	Symbol	Min	Typ	Max	Units
High-Level Input Voltage: XIN	V_{IH}	4.5	-	-	V
All Pins Except XIN	V_{IH}	2.0	-	-	V
Low-Level Input Voltage: XIN	V_{IL}	-	-	0.5	V
All Pins Except XIN	V_{IL}	-	-	0.8	V
High-Level Output Voltage (Note 11)	V_{OH}	$(V_{D+})-1.0$	-	-	V
Low-Level Output Voltage $I_{out} = 1.6mA$	V_{OL}	-	-	0.4	V
Input Leakage Current	I_{in}	-	1	10	μA
3-State Leakage Current	I_{OZ}	-	-	± 10	μA
Digital Output Pin Capacitance	C_{out}	-	9	-	pF

Notes: 11. $I_{out} = -100 \mu A$. This guarantees the ability to drive one TTL load. ($V_{OH} = 2.4V @ I_{out} = -40 \mu A$).

RECOMMENDED OPERATING CONDITIONS (AGND, DGND = 0V, see Note 12.)

Parameter		Symbol	Min	Typ	Max	Units
DC Power Supplies:	Positive Digital	VD+	4.5	5.0	5.5	V
	Negative Digital	VD-	-4.5	-5.0	-5.5	V
	Positive Analog	VA+	4.5	5.0	5.5	V
	Negative Analog	VA-	-4.5	-5.0	-5.5	V
Differential Analog Reference Voltage		(VREF+) - (VREF-)	2.0	2.5	3.8	V
Analog Input Voltage: (Note 13)	Unipolar	VAIN	0	-	+T	V
	Bipolar	VAIN	-T	-	+T	V

Notes: 12. All voltages with respect to ground.

13. The CS5516 and CS5520 can accept input voltages up to +T in unipolar mode and -T to +T in bipolar mode where $T = VREF / (G \times 25)$. G is the gain setting at the second gain block. When the inputs exceed these values, the CS5516 and CS5520 will output positive full scale for any input above T, and negative full scale for inputs below AGND in unipolar and -T in bipolar mode. This applies when the analog input does not exceed $\pm 2T$ overrange.

ABSOLUTE MAXIMUM RATINGS* (AGND, DGND = 0V, all voltages with respect to ground.)

Parameter		Symbol	Min	Typ	Max	Units
DC Power Supplies:	Positive Digital (Note 14)	VD+	-0.3	-	(VA+)+0.3	V
	Negative Digital	VD-	-0.3	-	-5.5	V
	Positive Analog	VA+	-0.3	-	5.5	V
	Negative Analog	VA-	+0.3	-	-5.5	V
Input Current, Any Pin Except Supplies (Notes 15, 16)		I_{in}	-	-	± 10	mA
Analog Input Voltage	AIN and VREF pins	V_{INA}	(VA-)-0.3	-	(VA+)+0.3	V
Digital Input Voltage		V_{IND}	-0.3	-	(VD+)+0.3	V
Ambient Operating Temperature		T_A	-55	-	125	°C
Storage Temperature		T_{stg}	-65	-	150	°C

Notes: 14. No pin should go more positive than (VA+)+0.3V. VD+ must always be less than (VA+)+0.3 V, and can never exceed 6.0V.

15. Applies to all pins including continuous overvoltage conditions at the analog input pins.

16. Transient currents of up to 100mA will not cause SCR latch-up. Maximum input current for a power supply pin is ± 50 mA.

* WARNING: Operation beyond these limits may result in permanent damage to the device. Normal operation is not guaranteed at these extremes.

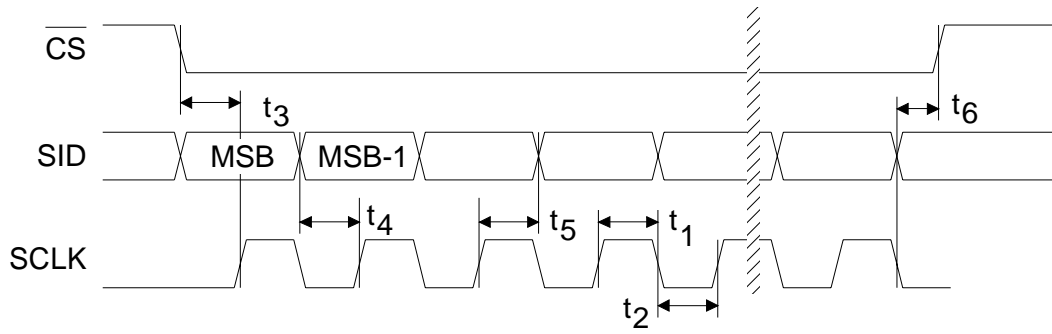

SID Write Timing (Not to Scale)

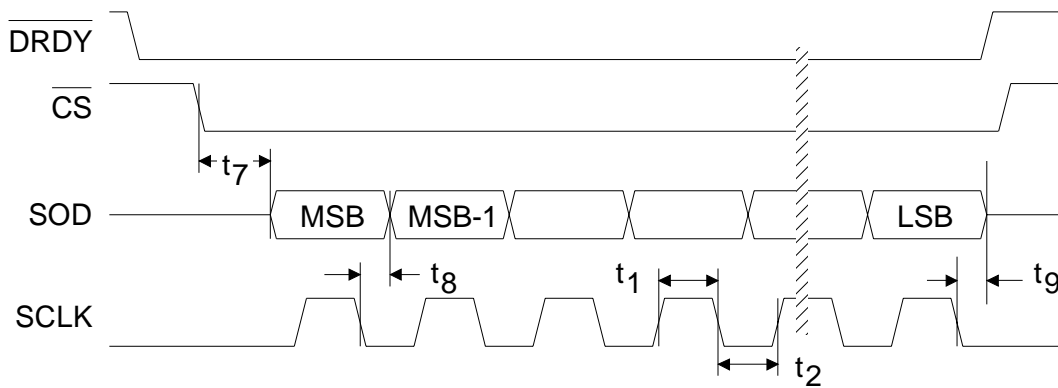

SOD Read Timing (Not to Scale)

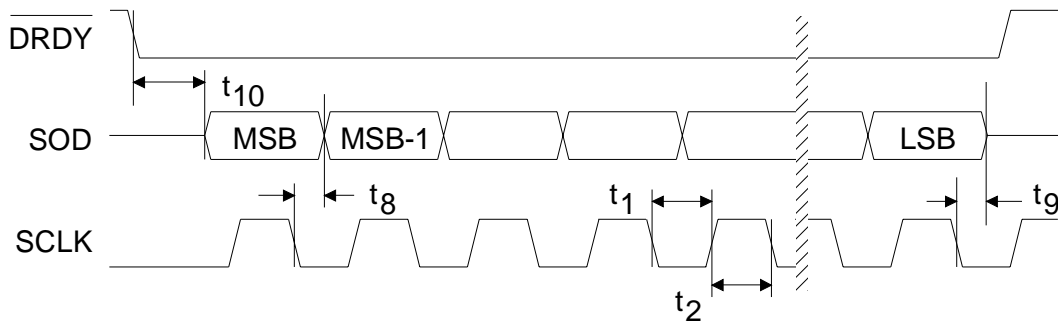

SOD Read Timing with CS = 0 (Not to Scale)

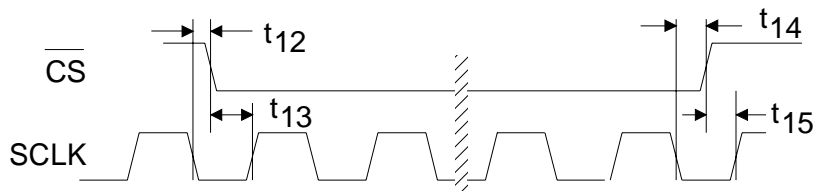

CS with Continuous SCLK (Not to Scale)

SWITCHING CHARACTERISTICS

($T_A = T_{MIN}$ to T_{MAX} ; V_{A+} , $V_{D+} = 5V \pm 5\%$;
 V_{A-} , $V_{D-} = -5V \pm 5\%$; Input Levels: Logic 0 = 0V, Logic 1 = V_{D+} ; $C_L = 50$ pF)

Parameter	Symbol	Min	Typ	Max	Units
Master Clock Frequency: Internal Oscillator / External Clock	XIN	1.0	4.096	5.0	MHz
Master Clock Duty Cycle		40	-	60	%
Rise Times	Any Digital Input (Note 18)	t_{rise}	-	1.0	μs
	Any Digital Output		50	-	ns
Fall Times	Any Digital Input (Note 18)	t_{fall}	-	1.0	μs
	Any Digital Output		50	-	ns
Startup					
Power-on Reset Period	t_{por}	-	100	-	ms
Oscillator Start-up Time	XTAL = 4.9152 MHz (Note 19)	t_{ost}	60	-	ms
RST Pulse Width	t_{res}	1/XIN	-	-	ns
Serial Port Timing					
Serial Clock Frequency	SCLK	-	-	2.4	MHz
Serial Clock	Pulse Width High	t_1	200	-	ns
	Pulse Width Low	t_2	200	-	ns
SID Write Timing					
CS Enable to Valid Latch Clock	t_3	150	-	-	ns
Data Set-up Time prior to SCLK rising	t_4	50	-	-	ns
Data Hold Time After SCLK Rising	t_5	50	-	-	ns
SCLK Falling Prior to CS Disable	t_6	50	-	-	ns
SOD Read Timing					
CS to Data Valid	t_7	-	-	150	ns
SCLK Falling to New Data Bit	t_8	-	-	170	ns
SCLK Falling to SOD Hi-Z	t_9	-	-	200	ns
DRDY Falling to Valid Data (CS = 0)	t_{10}	-	-	150	ns
CS Rising to SOD Hi-Z	t_{11}	-	-	150	ns
CS Disable Hold Time	t_{12}	50	-	-	ns
CS Enable Set-up Time	t_{13}	150	-	-	ns
CS Enable Hold Time	t_{14}	50	-	-	ns
CS Disable Set-up Time	t_{15}	150	-	-	ns

Notes: 18. Specified using 10% and 90% points on waveform of interest. Output loaded with 50 pF.

19. Oscillator start-up time varies with crystal parameters. This specification does not apply when using an external clock source.

GENERAL DESCRIPTION

The CS5516 and CS5520 are monolithic CMOS A/D converters which include an instrumentation amplifier input, an on-chip programmable gain amplifier, and a DAC for offset trimming. While the devices are optimized for ratiometric measurement of Wheatstone bridge applications, they can be used for general purpose low-level signal measurement.

Each of the devices includes a two-channel differential delta-sigma modulator (the signal measurement input and the reference input are digitized independently before a digital output word is computed), a calibration microcontroller, a two-channel digital filter, a programmable instrumentation amplifier block, a 4-bit DAC for

coarse offset trimming, circuitry for generation and demodulation of AC (actually switched DC) bridge excitation, and a serial port. The CS5516 outputs 16-bit words; the CS5520 outputs 20-bit words.

The CS5516/20 devices can measure either unipolar or bipolar signals. Self-calibration is utilized to maximize performance of the measurement system. To better understand the capabilities of the CS5516/20, it is helpful to examine some of the error sources in bridge measurement systems.

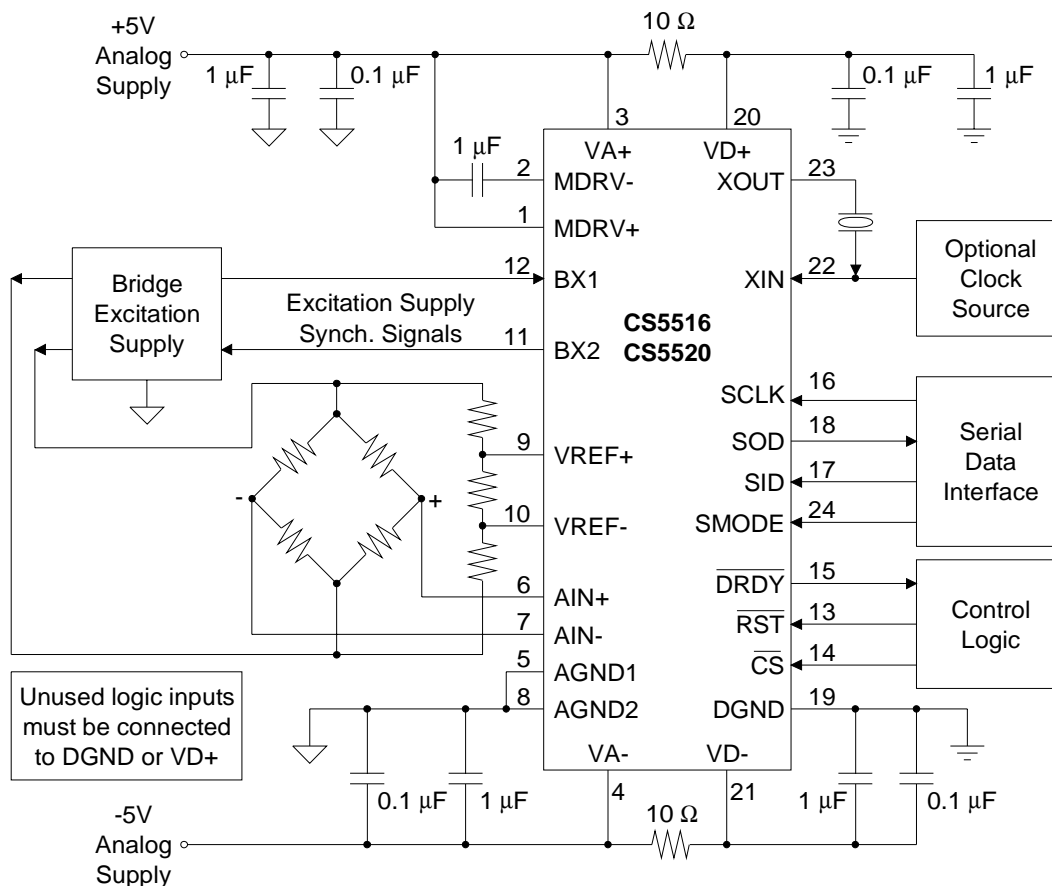

Figure 1. System Connection Diagram: AC Excitation Mode Using External Excitation

THEORY OF OPERATION

The front page of this data sheet illustrates the block diagram of the CS5516 and CS5520 A/D converter. The device includes an instrumentation amplifier with a fixed gain of 25. This chopper-stabilized instrumentation amplifier is followed by a programmable gain stage with gain settings of 1, 2, 4, and 8. The sensitivity of the input is a function of the programmable gain setting and of the reference voltage connected between the VREF+ and VREF- pins of the device. The full scale of the converter is $VREF/(G \times 25)$ in unipolar, or $\pm VREF/(G \times 25)$ in bipolar, where VREF is the reference voltage between the VREF+ and VREF- pins, G is the gain setting of the programmable gain amplifier, and 25 is the gain of the instrumentation amplifier.

After the programmable gain block, the output of a 4-bit DAC is combined with the input signal. The DAC can be used to add or subtract offset from the analog input signal. Offsets as large as $\pm 200\%$ of full scale can be trimmed from the input signal.

The CS5516 and CS5520 are optimized to perform ratiometric measurement of bridge-type transducers. The devices support dc bridge excitation or two modes of ac (switched dc) bridge excitation. In the switched-dc modes of operation the converter fully demodulates both the reference voltage and the analog input signal from the bridge.

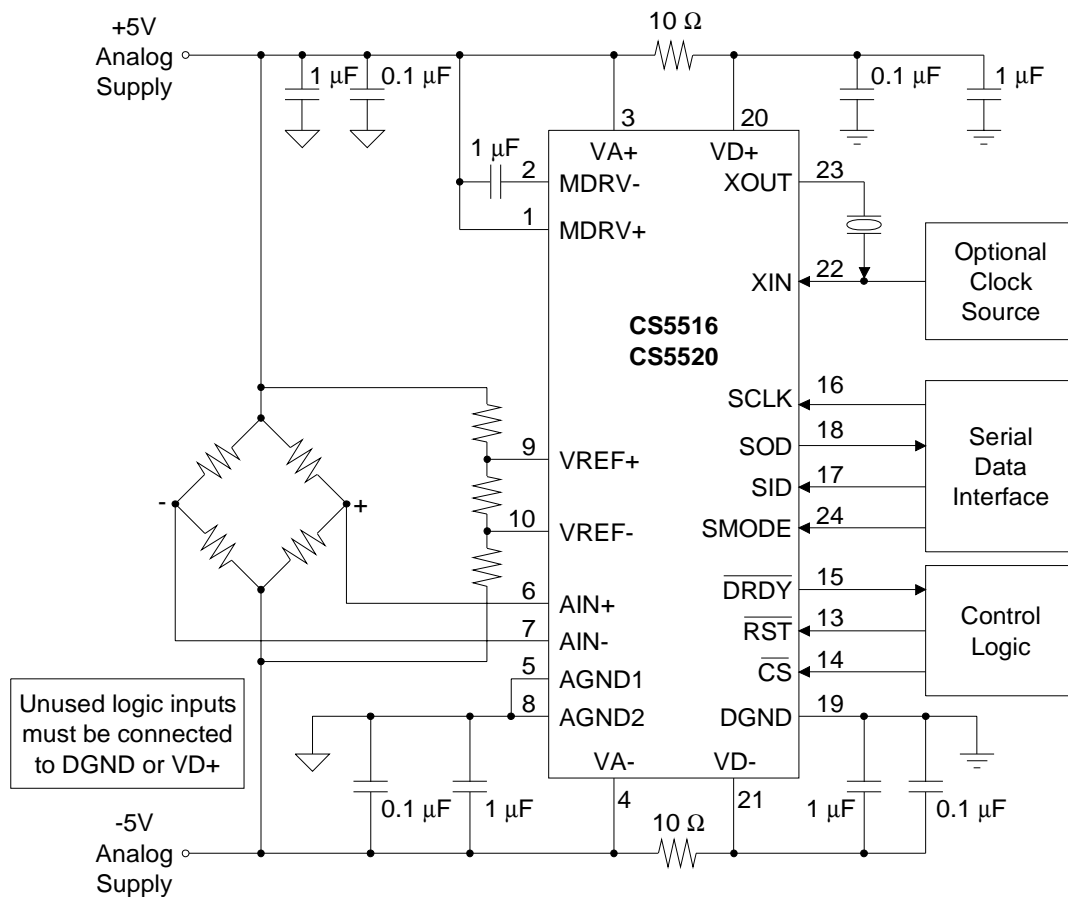

Figure 2. System Connection Diagram: DC Excitation Mode (EXC bit = 0), F1 = F0 = 0.

Command Register

D7	D6	D5	D4	D3	D2	D1	D0
1	RSB2	RSB1	RSB0	R/W	0	0	0

BIT	NAME	VALUE	FUNCTION
D7	D7	1	Must always be logic 1
RSB2-0	Register Select Bit	000 001 010 011 100 101 110 111	Selects Register to be Read or Written per R/W bit CONVERSION DATA (read only) CONFIGURATION GAIN DAC RATIOMETRIC OFFSET NON-RATIOMETRIC OFFSET - AIN NON-RATIOMETRIC OFFSET - VREF NOT USED
R/W	Read/Write	0 1	Write to the register selected by the RSB2-0 bits Read from the register selected by the RSB2-0 bits
D2	D2	0	Not Used
D1	D1	0	Not Used
D0	D0	0	Not Used

Table 1. CS5516 and CS5520 Commands

The CS5516/20 includes a microcontroller which manages operation of the chip. Included in the microcontroller are eight different registers associated with the operation of the device. An 8-bit command register is used to interpret instructions received via the serial port. When power is applied, and the device has been reset, the serial port is initialized into the command mode. In this mode it is waiting to receive an 8-bit command via its serial port. The first 8 bits into the serial port are placed into the command register. Table 1 lists all the valid command words for reading from or writing to internal registers of the converter. Once a valid 8-bit command word has been received and decoded, the serial port goes into data mode. In data mode the next 24 serial clock pulses shift data either into or out of the serial port. When writing data to the port, the data may immediately follow the command word. When reading data from the port, the user must pause after clocking in the 8-bit command word to allow the microcontroller time to decode the command word, access the appropriate regis-

ter to be read, and present its 24-bit word to the port. The microcontroller will signal when the 24-bit read data is available by causing the $\overline{\text{DRDY}}$ pin to go low.

The user must write or read the full 24-bit word except in the case of reading conversion data. In read data conversion mode, the user may read less than 24 bits if $\overline{\text{CS}}$ is then made inactive ($\overline{\text{CS}} = 1$). $\overline{\text{CS}}$ going inactive releases user control over the port and allows new data updates to the port.

The user can instruct the on-chip microcontroller to perform certain operations via the configuration register. Whenever a new word is written to the 24-bit configuration register, the microcontroller then decodes the word and executes the configuration register instructions. Table 2 illustrates the bits of the configuration register. The bits in the configuration register will be discussed in various sections of this data sheet.

Configuration Register

	D23	D22	D21	D20	D19	D18	D17	D16	D15	D14	D13	D12
Register	DAC3	DAC2	DAC1	DAC0	EXC	F1	F0	D16	G1	G0	U/B	D12
Reset (R)	0	0	0	0	0	0	0	0	0	0	0	0
	D11	D10	D9	D8	D7	D6	D5	D4	D3	D2	D1	D0
Register	A/S	EC	D9	D8	CC3	CC2	CC1	CC0	D3	D2	D1	RF
Reset (R)	0	0	0	0	0	0	0	0	0	0	0	0

BIT	NAME	VALUE		FUNCTION
DAC3	DAC Sign Bit	0 1	<i>R</i> ¹	Add Offset Subtract Offset This bit is read only ²
DAC2-0	DAC Bits	000 001 010 011 100 101 110 111	<i>R</i>	25% Offset 50% Offset 75% Offset 100% Offset 125% Offset 150% Offset 175% Offset These bits are read only ²
EXC	Excitation: Internal External	0 1	<i>R</i>	BX1 and BX2 outputs are determined by bits F1 and F0 BX1 is an input which determines the phase of the demodulation clock and the BX2 output
F1-F0	Select Frequency	00 01 10 11	<i>R</i>	Excitation on BX1 & BX2 is dc. BX1=0 V, BX2=+5 V Excitation Frequency on BX1 & BX2 is XIN/8192 Hz Excitation Frequency on BX1 & BX2 is XIN/16384 Hz Excitation Frequency on BX1 & BX2 is XIN/4096 Hz
D16	D16	0	<i>R</i>	Must always be logic 0
G1-G0	Select PGA Gain	00 10 01 11	<i>R</i>	Gain = 1 (X25) Gain = 2 (X25) Gain = 4 (X25) Gain = 8 (X25)
U/B	Select Unipolar/Bipolar Mode	0 1	<i>R</i>	Bipolar Measurement Mode Unipolar Measurement Mode
D12	D12	0	<i>R</i>	Must always be logic 0
A/S	Awake/Sleep	0 1	<i>R</i>	Awake Mode Sleep Mode
EC	Execute Calibration	0 1	<i>R</i>	Calibration not active Perform calibration selected by CC3-CC0 bits. EC bit must be written back to "0" after calibration is completed
D9	D9	0	<i>R</i>	Must always be logic 0
D8	D8	0	<i>R</i>	Must always be logic 0
CC3-CC0	Calibration Control Bits	0000 1000 0100 0010 0001	<i>R</i>	No calibration to be performed Calibrate non-ratiometric offset, VREF Calibrate non-ratiometric offset, AIN Calibrate ratiometric offset, AIN Calibrate gain, AIN
D3	D3	0	<i>R</i>	Must always be logic 0
D2	D2	0	<i>R</i>	Must always be logic 0
D1	D2	0	<i>R</i>	Must always be logic 0
RF	Reset Filter	0 1	<i>R</i>	Normal operation Reset Filter

Notes: 1.Reset State

2.A write to these bits does not change the register bit values. These bits are just a mirror of the DAC register contents.

Table 2. Configuration Register

System Initialization

Whenever power is applied to the CS5516/CS5520 A/D converters, the devices must be reset to a known condition before proper operation can occur. The internal reset is applied after power is established and lasts for approximately 100 ms. The $\overline{\text{RST}}$ pin can also be used to establish a reset condition. The reset signal should remain low for at least one XIN clock cycle to ensure adequate reset time. It is recommended that the $\overline{\text{RST}}$ pin be used to reset the converter if the power supplies rise very slowly or with poor startup characteristics. The $\overline{\text{RST}}$ signal can be generated by a microcontroller output, or by use of an R-C circuit.

The reset function initializes the configuration register and all five of the calibration registers; and places the microcontroller in command mode ready to accept a command from the serial port. Whenever the device is reset the $\overline{\text{DRDY}}$ pin will be set to a logic 1 and the on-chip registers are initialized to the following states:

Configuration	000000(H)
Calibration registers:	
DAC	000000(H)
Gain	800000(H)
AIN Ratiometric Offset	000000(H)
AIN Non-ratiometric Offset	000000(H)
VREF Non-ratiometric Offset	000000(H)

CALIBRATION

After the CS5516/20 is reset, the device is functional and can perform measurements without being calibrated. The converter will utilize the initialized values of the calibration registers to calculate output words.

The converter uses the two outputs (AIN & VREF) of the dual channel converter along with the contents of the calibration registers to compute the conversion data word. The following equation indicates the computation.

$$R0 = R4 \left[\left[\frac{D_{\text{AIN}} - R1}{D_{\text{VREF}} - R2} \right] - R3 \right]$$

Where R0 is the output data, D_{AIN} and D_{VREF} are the digital output words from the AIN and VREF digital filter channels, and R1, R2, R3 and R4 are the contents of the following calibration registers:

- R1 = AIN non-ratiometric offset
- R2 = VREF non-ratiometric offset
- R3 = AIN ratiometric offset
- R4 = Gain

The computed output word, R0, is a two's complement number.

Calibration minimizes the errors in the converted output data. If calibration has not been performed, the measurements will include offset and gain errors of the entire system.

The converter may be calibrated each time it is powered up, or calibration words from a previous calibration may be uploaded into the appropriate calibration registers from some type of E²PROM by the system microcontroller.

The converter uses five different registers to store specific calibration information. Each of the calibration registers stores information pertinent to correcting a specific source of error associated with either the converter or with the input transducer and its wiring. The method by

Configuration Register					CAL Type	Calibration Time
EC	CC3	CC2	CC1	CC0		
1	1	0	0	0	VREF Non-ratiometric Offset	573,440/fclk
1	0	1	0	0	AIN Non-ratiometric Offset	573,440/fclk
1	0	0	1	0	AIN Ratiometric Offset	2,211,840/fclk
1	0	0	0	1	AIN System Gain	573,440/fclk
1	1	1	0	0	VREF & AIN Non-ratiometric Offset	573,440/fclk
0	X	X	X	X	End Calibration	-

$\overline{\text{DRDY}}$ remains high through calibration sequence. In all modes, $\overline{\text{DRDY}}$ falls immediately upon completion of the calibration sequence.

Table 3. CS5516/CS5520 Calibration Control

which calibration is initiated is common to each of the calibration registers. The configuration register controls the execution of the calibration process. Bits CC3--CC0 in the configuration register determine which type of calibration will be performed and which of the five calibration registers will be affected. On the falling edge of the 24th SCLK, the configuration word will be latched into the configuration register and the selected calibration will be executed. The time required to perform a calibration is listed in Table 3. The DRDY pin will remain a logic 1 during calibration, and will go low when the calibration step is completed.

The serial port should not be accessed while a calibration is in progress. The EC bit of the configuration register remains a logic 1 until it is overwritten by a new configuration word (EC = 0). Consequently, if EC is left active, any write (the falling edge of the 24th SCLK) to any register inside the converter will cause a re-execution of the calibration sequence. This occurs because the internal microcontroller executes the contents of the configuration register every time the 24th SCLK falls after writing a 24-bit word to any internal register. To be certain that calibrations will not be re-executed each time a new word is written or read via the serial port, the EC bit of the configuration register must be written back to a logic 0 after the final calibration step has been completed.

The CC3--CC0 bits of the configuration register determine the type of calibration to be per-

formed. The calibration steps should be performed in the following sequence. If the user determines that non-ratiometric offset calibration is important, the non-ratiometric offset errors of the VREF and AIN input channels should be calibrated first. Then the ratiometric offset of the AIN channel should be calibrated. And finally, the AIN channel gain should be calibrated.

Non-ratiometric Errors

To calibrate out the VREF and AIN non-ratiometric errors, the input channels to the VREF path into the converter and the AIN path into the converter must be grounded (this may occur at the pins of the IC, or at the bridge excitation as shown in Figure 3.). Then the EC, CC2 and CC3 bits of the configuration register must be set to logic 1. The converter will then perform a non-ratiometric calibration and place

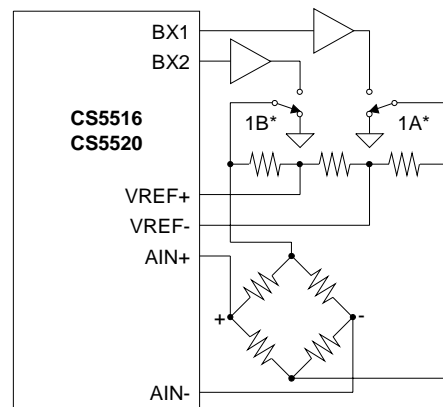

*Note: The bridge can be grounded with a relay or with jumpers to perform non-ratiometric calibration.

Figure 3. Non-ratiometric System Calibration using Internal Excitation

the proper 24 bit calibration words in the VREF and AIN non-ratiometric registers. Note that the two non-ratiometric offsets can be calibrated simultaneously or independently, but they must be calibrated prior to the other calibration steps if non-ratiometric offset calibration is to be used. If the effects of the non-ratiometric errors are not significant enough to affect the user application, they can be left uncalibrated (after a reset, the non-ratiometric offset registers will contain 000000(H)).

Ratiometric Offset

Once the non-ratiometric errors have been calibrated, the ratiometric offset error of the AIN channel should be calibrated next. To perform this calibration step, a reference voltage must be applied to the VREF+ and VREF- pins. Then, place "zero" weight on the scale platform. This will result in an offset voltage into the converter which will represent the offset of the bridge, the wiring, and the AIN input of the converter itself. A configuration word with the EC and CC1 bits set to logic 1 is then written into the configuration register. During the ratiometric offset calibration of AIN the microcontroller first uses a successive approximation algorithm to compute the correct values for the DAC3-DAC0 bits of the DAC register. This accommodates any large offsets on the AIN input signal. Once the four DAC bits are computed, this amount of offset is removed from the input signal. The microcontroller then computes the appropriate 24 bit number to place in the AIN ratiometric offset register to calibrate out the remaining offset not removed by the DAC.

Gain

After the AIN ratiometric offset has been calibrated, the next step is to perform a gain calibration. Gain calibration is performed with "full scale" weight on the scale platform. The EC and CC0 bits of the configuration register are set to logic 1. The gain calibration of the AIN channel is the final calibration step. After

$\overline{\text{DRDY}}$ falls to signal the completion of this calibration step, the EC bit of the configuration register must be set back to logic 0 to terminate the calibration mode.

Limitations in Calibration Range

There are five calibration registers in the converter. There are two non-ratiometric offset calibration registers, one for the AIN input and one for the VREF input; one 4-bit offset trim DAC; one ratiometric offset calibration register for the AIN input; and one gain calibration register. After the non-ratiometric offsets are calibrated, an LSB in either of the 24-bit non-ratiometric calibration registers represents 2^{-23} proportion of an internally-scaled MDRV (Modulator Differential Reference Voltage). At the MDRV+ and MDRV- pins, the MDRV has a nominal value of 3.75 volts. This voltage is internally scaled to a nominal 2.5 volts (never less than 2.4 volts) for use with the non-ratiometric calibration. The two non-ratiometric calibration words are stored in 2's complement form with one count equal to slightly less than 300 nV at the input of the internal A/D converter. For the AIN channel this will be scaled down by the gain of the instrumentation amplifier (X25) and the PGA gain. For a PGA gain = 1, one count of a non-ratiometric register will represent slightly less than 12 nV. Non-ratiometric offset at the VREF input cannot exceed ± 2.4 volts to be within calibration range of the converter. Non-ratiometric offset to be calibrated by the AIN channel cannot exceed ± 2.4 volts divided by the channel gain. With a PGA gain = 1, the maximum non-ratiometric offset which can be calibrated on the AIN channel cannot exceed ± 96 mV.

When the ratiometric offset is calibrated, the 4-bit DAC coarsely trims offset from the analog signal. The ratiometric offset which remains is finely trimmed after the signal has been converted; using the contents of the ratiometric offset register for digital correction. The DAC

bits can be manipulated by the user to add or subtract offset up to 200 percent of the nominal input signal. The AIN ratiometric offset register can be manipulated to add or subtract offset equal to the maximum differential input signal into the X25 amplifier. An LSB in the ratiometric offset register represents 2^{-23} proportion of the voltage input across the VREF+ and VREF- pins at the internal input to the AIN channel A/D converter. This will be scaled down by the AIN channel gain when calculated relative to the instrumentation amplifier input. For example, with a VREF = 2.5 V, the PGA gain = 1, one count of the ratiometric offset register would represent about 12 nV at the instrumentation amplifier input. The proportion remains ratiometric even if the VREF voltage should change. The 24-bit register content is stored in 2's complement form.

Manipulation of the DAC or ratiometric offset register allows the user to shift the transfer function to allow for load cell creep or load cell zero drift.

The gain calibration is performed last. The contents of the gain register spans from 2^{-23} to 2 as shown in Table 4. After gain calibration has been performed, the numeric value in the gain register should not exceed the range of 0.8 to 1.2. The gain calibration range is $\pm 20\%$ of the nominal value of 1.0. The nominal value of 1.0 is for an input span dictated by the VREF voltage, the PGA gain, and the X25 instrumentation gain. The converter may operate with gain slope factors from 0.5 to 2.0 (decimal), but when the slope exceeds 1.2 the converter output code computation may lack adequate resolution and result in missing codes in the transfer function. Internal circuitry may saturate for large signals which would calibrate to a gain factor less than 0.8.

In a typical weigh scale application, the CS5516/CS5520 will be calibrated in combination with a load cell at the factory. Once calibrated, the calibration words are off-loaded from the converter and stored in E²PROM. When powered-up in the field the calibration words are up-loaded into the appropriate registers. This is viable because the AIN and VREF input to the converter are "chopper-stabilized" and maintain excellent stability when subjected to changes in temperature.

Programmable Gain Amplifier

The programmable gain amplifier inside the CS5516/20 offers gains of 1, 2, 4, and 8. This is in addition to the fixed gain of $\times 25$ in the input instrumentation amplifier. The gain tracking of the PGA is about one percent between ranges. The user can remove this error by performing a gain calibration at the factory with a full scale signal on each range. The gain calibration word for each gain range can be off-loaded into E²PROM and uploaded into the gain register whenever a new gain setting is selected for the PGA. Gain stability over temperature for the converter itself is approximately 1 ppm/°C when the device is used ratiometrically.

Serial Interface Modes

The CS5516/20 support either 5, 4 or 3 pin serial interfacing. The SMODE pin sets the operating mode of the serial interface. With SMODE = 0, the device assumes the user is operating with either a 5 or 4 wire interface. The five wire mode includes SOD, SID, SCLK, $\overline{\text{DRDY}}$, and $\overline{\text{CS}}$. In the four wire mode, $\overline{\text{CS}}$ is connected to DGND as a logic 0. The user would then interface to the SOD, SID, SCLK, and $\overline{\text{DRDY}}$ pins.

AIN and VREF Non-Ratiometric Offset Registers

	MSB												LSB					
Register	2^0	2^1	2^2	2^3	2^4	2^5	}}						2^{-18}	2^{-19}	2^{-20}	2^{-21}	2^{-22}	2^{-23}
Reset (R)	0	0	0	0	0	0	}}						0	0	0	0	0	0

One LSB represents 2^{-23} proportion of the internal MDRV (≈ 2.5 Volts)

DAC Register

	D23	D22	D21	D20	D19	D18	D17	D16	D15	D14	D13	D12
Register	DAC3	DAC2	DAC1	DAC0	EXC	F1	F0	D16	G1	G0	U/B	D12
Reset (R)	0	0	0	0	0	0	0	0	0	0	0	0

	D11	D10	D9	D8	D7	D6	D5	D4	D3	D2	D1	D0
Register	A/S	EC	D9	D8	CC3	CC2	CC1	CC0	D3	D2	D1	RF
Reset (R)	0	0	0	0	0	0	0	0	0	0	0	0

BIT	NAME	VALUE		FUNCTION
DAC3	DAC Sign Bit	0 1	R^1	Add Offset Subtract Offset
DAC2-0	DAC Bits	000 001 010 011 100 101 110 111	R	25% Offset 50% Offset 75% Offset 100% Offset 125% Offset 150% Offset 175% Offset
Bits D19 to D0		0	R	These bits mirror the Configuration Register read only ²

Note: 1. Reset State

2. A write to these bits does not change the register bit values.

AIN Ratiometric Offset Register

	MSB												LSB					
Register	2^0	2^1	2^2	2^3	2^4	2^5	}}						2^{-18}	2^{-19}	2^{-20}	2^{-21}	2^{-22}	2^{-23}
Reset (R)	0	0	0	0	0	0	}}						0	0	0	0	0	0

One LSB represents 2^{-23} proportion of the voltage [$\langle VREF+ \rangle - \langle VREF- \rangle$]/GAIN] where GAIN = 25 X PGA Gain

GAIN Register

	MSB												LSB					
Register	2^0	2^1	2^2	2^3	2^4	2^5	}}						2^{-18}	2^{-19}	2^{-20}	2^{-21}	2^{-22}	2^{-23}
Reset (R)	1	0	0	0	0	0	}}						0	0	0	0	0	0

The gain register span from 0 to $(2-2^{-23})$. After Reset the MSB=1, all other bits are 0.

Table 4. Calibration Registers

Reading a register in the converter requires a command word to be written to the SID pin. For example, to read the conversion data register, the following command sequence should be performed. First, the command word 88(H) would be issued to the port. In the 5 wire interface mode, this would involve activating \overline{CS} low, followed by 8 SCLKs (note that SCLK must always start low and transition from low to high to latch the transmit data, and then back low again) to input the 8-bit command word. \overline{CS} must be low for the serial port to recognize SCLKs during a write or a read, but it is actually the first rising SCLK during command time that gives the user control over the port. After writing the command word, the user must pause and wait until the CS5520 presents the selected register data to the serial port. The \overline{DRDY} signal will fall when the data is available. When reading the conversion data register, it may take up to 112,000 XIN clock cycles for \overline{DRDY} to fall after the 88(H) command word is recognized. See Figure 4 for an illustration of command and data word timing.

The conversion data register is actually the accumulator of the post-processor which computes the output data. At the end of each filter convolution cycle, the internal microcontroller checks to see if a read conversion data register command has been interpreted. If so, it transfers the accumulator result to the serial port.

Whenever registers other than the conversion data register are read, the \overline{DRDY} pin will fall within 256 XIN clock cycles (62.5 μ s with XIN = 4.096 MHz) after the command word is recognized. When \overline{DRDY} falls, 24 SCLKs are then issued to the port to read the 24-bit output data word. \overline{DRDY} will return high after all 24 bits have been clocked out. The SOD pin will be in a Hi-Z state whenever \overline{CS} is high, or after all 24 output data bits have been clocked out of the port.

The CS5516/20 is designed such that it can output conversion data words continuously, without issuing a new command word prior to each data read. Under the following circumstances, continuous conversion data can be read from the port after issuing only one 88(H) command word. Once the command to read the conversion data register is issued, \overline{DRDY} must be allowed to go low, after which 24 SCLKs are issued to read the data. This will cause \overline{DRDY} to return high.

The converter will continue to output conversion words at the update rate as long as a different command word is not started prior to \overline{DRDY} falling again. The user is not required to read every output word to remain in the continuous update mode. \overline{DRDY} will toggle high, and then low as each new output word becomes available. If a command word is issued immediately after a data word is read, the converter will end the read conversion mode. Figure 5 illustrates the continuous data mode.

The user should perform all data reads and command writes within 51,000 XIN clock cycles after \overline{DRDY} falls to avoid ambiguity as to who controls the serial port.

If SMODE = 1 (tied to VD+), the interface operates as a 3 wire interface using only SOD, SID, and SCLK. In the 3 wire mode \overline{CS} must be tied to DGND. \overline{DRDY} operates normally but is not used. Instead, the \overline{DRDY} signal modifies the behavior of the SOD signal, allowing it to signal to the user when data is available. To read data from the converter requires a command word to be written to the SID pin. The SOD output is normally high (never Hi-Z). When output data is available, the SOD signal will go low. The user would then issue 8 SCLKs to the SCLK pin to clear this data ready signal. On the falling edge of the 8th SCLK the SOD pin will present the first bit of the 24-bit output word. 24 SCLKs are then issued to read the data. Then SOD will go high. SID should remain low whenever the

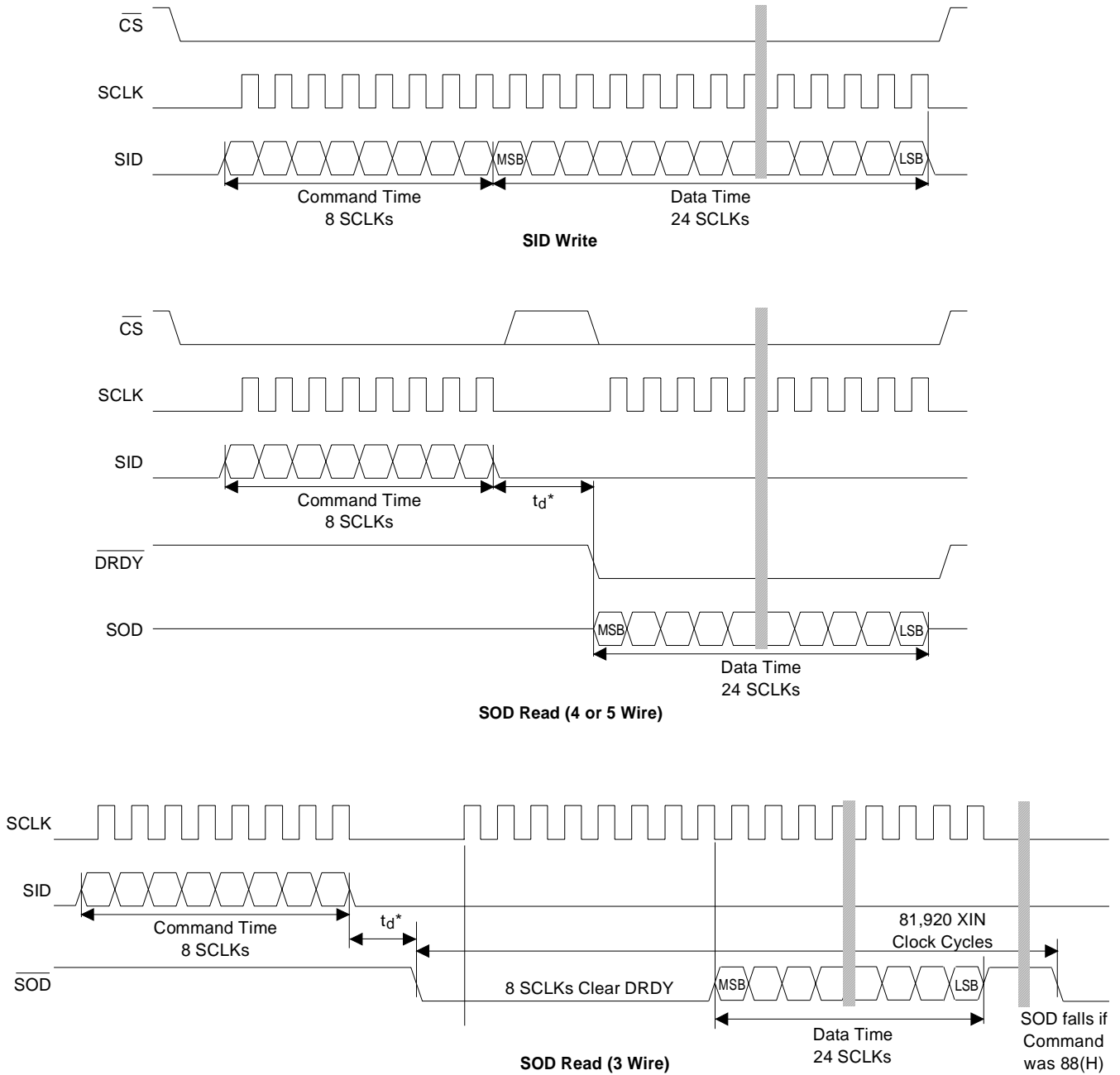

Figure 4. Command and Data Word Timing

*See text for t_d time.

SID pin is not being written. When reading SOD, SCLK cannot be continuous but must burst one clock cycle per bit.

The continuous read conversion data mode is also functional in the 3-wire interface mode. Issue one 88(H) command word to the converter. Then wait for SOD to go low. Issue 8 SCLKs to clear the data ready function. The MSB data bit will then appear on the SOD pin. Issue 24 SCLKs to read the conversion word. At the falling edge of the 24th SCLK SOD will return high. SOD will go low at the next DRDY falling time to indicate a new conversion word. Eight SCLKs must again be issued to clear the data ready function before clocking out the data conversion word. The SOD pin will continue to toggle low each time a word is available even if the conversion data is not read. To terminate the continuous conversion mode, input an 8-bit command word immediately after reading a conversion word.

The user should perform all data reads and command writes within 51,000 XIN clock cycles after SOD falls to avoid ambiguity as to who controls the serial port.

Serial Port Initialization

If for any reason the off-chip microcontroller fails to know whether the serial port of the CS5516/20 is in data mode or command mode, the following initialization procedure can be issued to the port to force the CS5516/20 into the command mode. Write 128 or more 1's to the SID pin. Then issue a single 0 to the SID pin. The port will then be initialized into the command mode and will be waiting for an 8-bit command word.

Bridge Excitation Options

The CS5516/CS5520 A/D converters are optimized for Wheatstone bridge applications. The converters support either dc or ac (switched dc) bridge excitation.

DC Bridge Excitation

The CS5516/CS5520 can be configured for dc bridge excitation in either of two ways. The EXC bit of the configuration register can be set for either internal or for external excitation. If set to internally-controlled mode (EXC = 0), the F1 and F0 bits must be set to logic 0s. In this condition, the bridge can be excited from a dc supply with a resistor divider to develop the appropriate reference voltage for the VREF+ and VREF- pins. Note that the bridge excitation

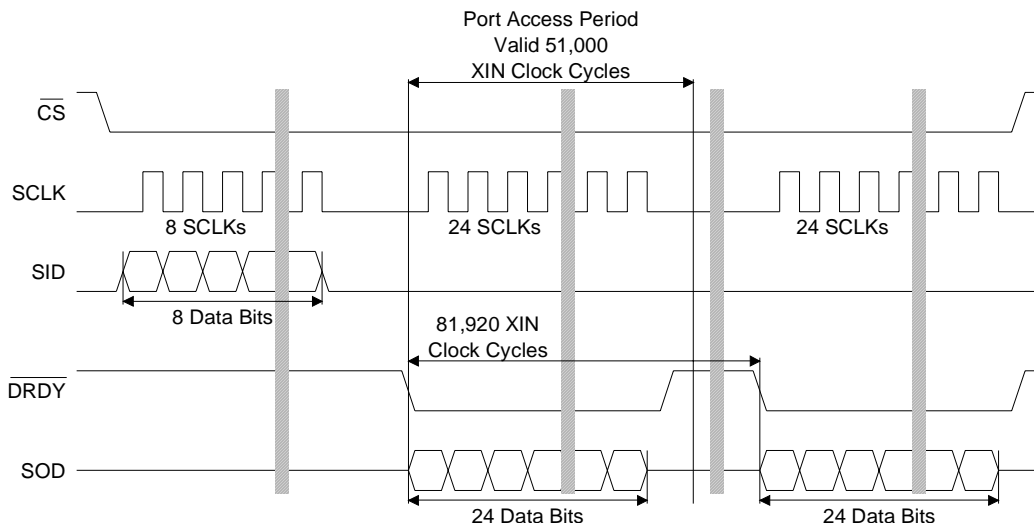

Figure 5. Continuous Read Conversion Data Mode (4 or 5 Wire)

should not be applied prior to the CS5516/CS5520 being powered-up. With EXC, F1, and F0 set to logic 0, the BX1 output will be logic 0 (0 volts) and the BX2 output will be a logic 1 (+5 volts).

A second method for configuring the converter for dc excitation is by setting EXC = 1, and pulling up BX1 (pin 12) to VD+ (pin 20) through a resistor. This sets the converter for use with external excitation which uses the BX1 pin as an input to set the excitation frequency. With BX1 = VD+, the external excitation frequency is zero, or dc.

AC Bridge Excitation

AC bridge excitation involves using a clock signal to generate a square wave which repetitively reverses the excitation polarity on the bridge. To excite the bridge dynamically requires some type of bridge driver external to the CS5516/CS5520 converter. This driver is driven by a square wave clock. The source of this clock depends upon whether the converter is set for internal excitation or for external excitation. Figure 6 illustrates a sample bridge drive circuit when operating in the internal AC excitation mode.

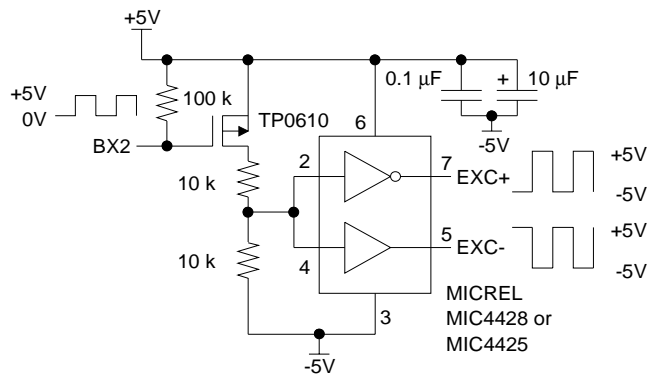
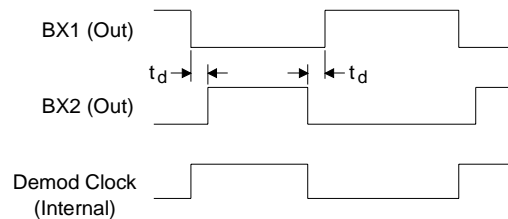

Figure 6. Sample AC Bridge Driver

Using internal excitation involves setting the EXC bit of the configuration register to 0, and setting the F1 and F0 bits to select the excitation frequency for the bridge. In this mode the excitation frequency is a sub-multiple of the XIN clock frequency. The excitation clock is output

from the BX1 and BX2 pins of the converter in the form of a two-phase non-overlapping clock. The converter is capable of demodulating this clocked excitation. But only if the signals into the AIN+ and VREF+ pins of the converter are in phase with the demodulation clock inside the converter (see Figure 7). The non-overlapping clock signals from BX1 and BX2 are CMOS level outputs (0 to VD+ volts) and are capable of driving one TTL load. A buffer amplifier **MUST** be used to drive the bridge.



Note: The signals from the bridge into AIN+ and VREF+ of the converter must be in phase with the demodulation clock.
t_d is 1 cycle of XIN clock.

Figure 7. Internal Excitation Clock Phasing

Whenever the internal mode is used for dynamic bridge excitation the signals are non-overlapping. The non-overlapping time is one XIN clock cycle.

The converter can also be configured to provide dynamic bridge excitation when operating in the external-controlled bridge excitation mode. With the EXC bit of the configuration register set to logic 1, the BX1 pin becomes an input which determines the bridge excitation frequency and phase. BX1 should be near 50% duty cycle. The user can select the excitation frequency with the following restrictions. The excitation frequency must be synchronous with the XIN frequency of the converter and must be chosen using the following equation:

$$F_{exc} = (N \times XIN) / 81,920$$

where N is an integer and lies in the range including 1 to 160. F_{exc} is the desired bridge excitation frequency. Other asynchronous fre-

quencies are possible but may introduce a jitter component in the BX output signals. It is desirable not to choose an excitation frequency where interference components are present, such as 50 Hz or 60 Hz or their harmonics. The XIN frequency can be divided down using a counter IC external to the A/D converter. F_{exc} would be input to the BX1 pin of the converter to synchronize the internal operations of the amplifiers and synchronous detection circuitry and to generate a clock output from the BX2 pin. The BX2 output is then used to drive the bridge amplifier with a signal of proper phase for detection by the converter. Figure 8 indicates the necessary phase of the signals to ensure proper demodulation.

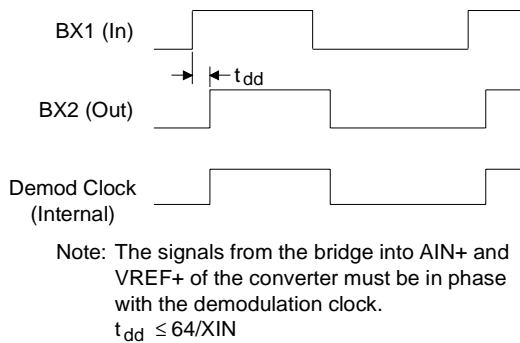

Figure 8. External Excitation Clock Phasing

Whenever the dynamic excitation clock output from either the BX1 and BX2 pins (during internal excitation) or from the BX2 pin (during external excitation) changes states, the converter waits 64 XIN cycles before sampling the AIN and VREF signal inputs. The delay allows some time for the signal to settle from the modulation event.

Input Filtering

Some load cells are located a distance from the input to the converter. Under these conditions, separate twisted pair cabling is recommended for the excitation drive to the bridge, the excitation sense leads (if used), and for the AIN±/AIN- signal leads. If the AIN+/AIN- leads to the con-

verter and the VREF+/VREF- leads to the converter are filtered, care should be exercised in the choice of components. With either dc or ac excitation, one should limit any input filtering resistors on AIN to below 1 kΩ. Values greater than this will degrade noise performance of the converter. In ac excitation applications, any filtering must be broadband enough that the switched dc excitation signal can settle within 10 μsecs. Failure to meet this settling requirement will affect measurement accuracy. Figure 9 illustrates acceptable filter components for ac excitation. If only differential filtering is required, a single capacitor can be placed between AIN+ and AIN- (and VREF+ and VREF-) in place of two capacitors to ground.

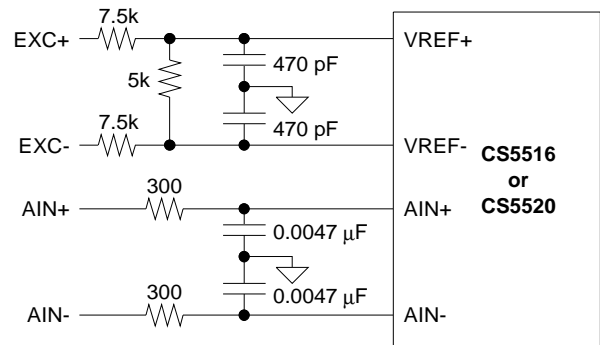

Figure 9. AIN and VREF Input Filter Components

Voltage Reference Considerations

The CS5516/20 include an on-chip voltage reference which is output on the MDRV- and referenced from the MDRV+ pin. The converter is designed to be operated as a ratiometric measurement device. The 2-channel delta-sigma converter uses the internal MDVR (Modulator Differential Voltage Reference) as its reference. Since the MDVR is used for converting both the AIN and VREF signals at the same time, the absolute value of the MDVR and its tempco are not important when the CS5516/20 is used in the ratiometric measurement mode. The voltage reference output, MDVR-, should be decoupled using a 1 μF capacitor which is connected to the MDRV+ supply line. Voltage reference decou-

pling is shown on the system connection diagrams.

If absolute measurements are to be made by the CS5516/20, then a precision reference should be input into the VREF+ and VREF- terminals.

Clock Generator

The CS5516/20 includes a gate which can be connected as a crystal oscillator to provide the master clock to run the chip. Alternatively, an external (CMOS compatible) clock can be input into the XIN pin. Figure 10 illustrates a simple model for the on-chip gate oscillator. The on-chip oscillator is designed to typically operate with crystal frequencies between 4.0 and 5.0 MHz without additional loading capacitors. If other crystal frequencies, or if ceramic resonators are used, additional loading capacitance may be necessary.

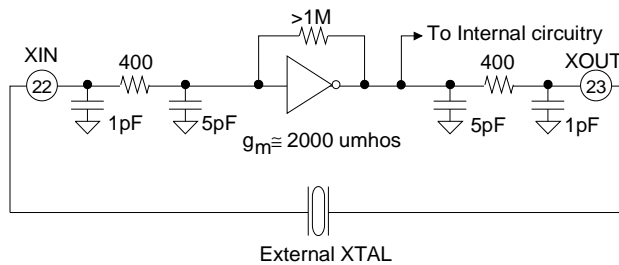

Figure 10. On-Chip Gate Oscillator Model

The XOUT pin can be used to drive one CMOS gate for system clock requirements. Be sure to include the gate's input capacitance and stray capacitance as part of the loading capacitance for the resonating element.

Digital Filter

The CS5516/20 is optimized to operate with clock frequencies of 4.096 MHz or 4.9152 MHz. These result in the filter having a 3dB bandwidth of 12 Hz or 15 Hz, with output word rates of 50 or 60 Sps. The rejection at 50Hz \pm 3Hz is 70 dB minimum with a 4.096 MHz clock. Similar rejection is obtained at 60 Hz with a 4.9152 MHz clock.

The digital filter has a deep notch in its transfer function at 50 Hz (XIN = 4.096 MHz) or 60 Hz (XIN = 4.9152 MHz) but other XIN frequencies can be used. The filter transfer function will scale proportionally. Figure 11 shows the transfer function of the filter when operated at three different frequencies. With a 3.579 MHz XIN, the filter offers greater than 90 dB rejection of both 50 and 60 Hz.

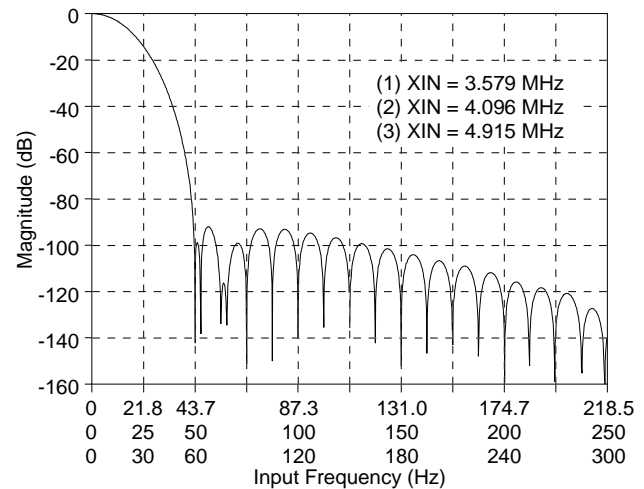

Figure 11. Filter Magnitude Response

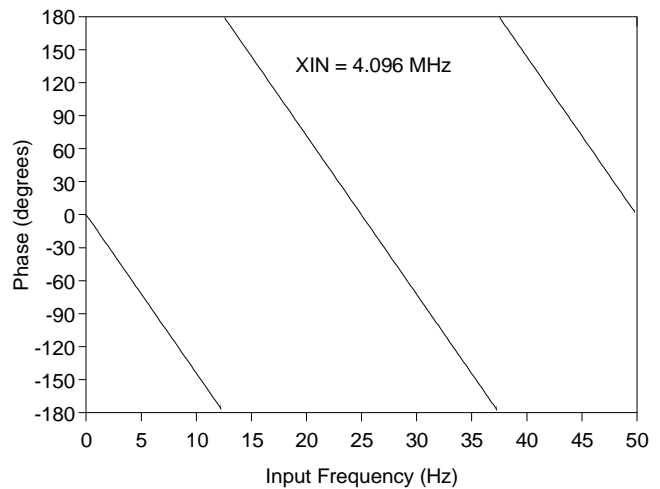

Figure 12. Filter Phase Response.

The output word rate of the converter scales with the XIN clock rate and is set by the ratio of XIN/81,920; or 50 Sps for XIN = 4.096 MHz. If very narrow signal bandwidths, such as 3 Hz, are desired, averaging of the output words is recommended.

The digital filter computes a new output data word every 81,920 XIN clock cycles. If the input experiences a large change in amplitude, the PGA gain is changed, or the DAC calibration registers are changed, it may take up to six filter cycles (81,920 X 6 clock cycles) for the filter to compute an output word which is fully settled to the input signal.

Output Coding

The CS5516/20 converters output data in binary format when operating in unipolar mode and in two's complement when operating in bipolar mode. Table 5 illustrates the output coding for the converters. Note that when reading conversion data from the converter the data word is output MSB or sign bit first. Falling edges on SCLK advance the data word to the next lower bit.

The output conversion words from both the CS5516 and the CS5520 are 24 bits long. The CS5516 has 16 data bits followed by 8 flag bits (all identical). The CS5520 has 20 data bits followed by 4 flag bits (all identical). To read the conversion data, including the error flag information will require at least 17 SCLKs for the CS5516 and at least 21 SCLKs for the CS5520.

Under normal operating conditions, the flag bits will be zeroes. The flag bits will be set to all ones whenever an overrange condition exists. Under large overrange conditions where the input signal exceeds the nominal full scale input by approximately two times (for example: 50 mV input when the nominal full scale input is set-up for 25 mV), the converter may be unable to compute a proper output code. In this condition flag bits will be set to all 1s but the conversion data may be a value other than full scale plus or minus.

After the converter is first powered-up, a \overline{RST} is issued, or the device comes out of the SLEEP mode, the first conversion data read may erroneously have its error flag bits set to "1".

Synchronizing Multiple Converters

Multiple converters can be made to output their conversion words at the same time if they are operated from the same clock signal at XIN. To synchronize multiple converters requires that they all have their RF bit of the configuration register written to a logic 1 and then back to 0. The filters will be allowed to start convolutions after the falling edge of the 24th SCLK used to write the RF bit to the configuration register.

Unipolar Input Voltage	Offset Binary	Bipolar Input Voltage	Two's Complement
>(VFS-1.5 LSB)	FFFF	>(VFS-1.5 LSB)	7FFF
VFS-1.5 LSB	FFFF ---- FFFF	VFS-1.5 LSB	7FFF ---- 7FFE
VFS/2-0.5 LSB	8000 ---- 7FFF	-0.5 LSB	0000 ---- FFFF
+0.5 LSB	0001 ---- 0000	-VFS+0.5 LSB	8001 ---- 8000
<(+0.5 LSB)	0000	<(-VFS+0.5 LSB)	8000

CS5516 Output Coding

Unipolar Input Voltage	Offset Binary	Bipolar Input Voltage	Two's Complement
>(VFS-1.5 LSB)	FFFFF	>(VFS-1.5 LSB)	7FFFF
VFS-1.5 LSB	FFFFF ---- FFFFE	VFS-1.5 LSB	7FFFF ---- 7FFFE
VFS/2-0.5 LSB	80000 ---- 7FFFF	-0.5 LSB	00000 ---- FFFFF
+0.5 LSB	00001 ---- 00000	-VFS+0.5 LSB	80001 ---- 80000
<(+0.5 LSB)	00000	<(-VFS+0.5 LSB)	80000

CS5520 Output Coding

Note: VFS in the table equals the full scale voltage between +VREF/(G x 25) and ground for unipolar mode; and between $\pm VREF/(G \times 25)$ for bipolar mode. The signal input to the A/D section of the converter has been amplified by the instrumentation amplifier (x25) and the PGA gain, G (1, 2, 4, or 8). See text about error flags under overrange conditions.

Table 5. Output Coding for the CS5516/20 Converters.

The filter will start a new convolution on the next rising edge of the XIN clock after the 24th SCLK falls.

Sleep Mode

The CS5516/20 configuration register has an A/S bit which allows the users to put the device in a sleep condition to lower quiescent power. Upon reset the A/S bit device is set to a logic 0 which places the device in the 'awake' condition. Writing a 1 to the A/S bit will shutdown most of the chip, including the oscillator. It is desirable to use the following sequence when coming out of sleep. Write a logic 0 to the A/S bit of the configuration register. In the same configuration word write a logic 1 to the RF bit of the configuration register. Then wait until it is certain that the oscillator has started. After the oscillator has started or a clock present on the XIN pin, set the RF bit back to 0. The user should then wait at least 6 output word update periods before expecting a valid output data word.

Noise Performance

Typical noise performance for the converter is listed in the specification tables for each PGA gain. Figure 13 illustrates a noise histogram for 1000 output conversions from the CS5520. The data for the histogram was collected using the CDB5520 evaluation board; with VREF at 2.5 volts, PGA = 4, bipolar mode. The data shows the standard deviation of the data set is 3.2 LSBs. One LSB is equivalent to $[VREF \times 2(\text{bipolar})] / [\text{Inst amp gain} \times \text{PGA gain} \times \text{number of codes}]$ or $(2.5 \times 2) / (25 \times 4 \times 2E20) = 47.7 \text{ nV}$. One standard deviation is equivalent to rms if the data is Normal or Gaussian. The rms noise presented by the plot is 153 nV, which is in good agreement with the typical noise specification of 150 nV for a PGA gain of 4.

Applications

See the Application Notes section of the databook.

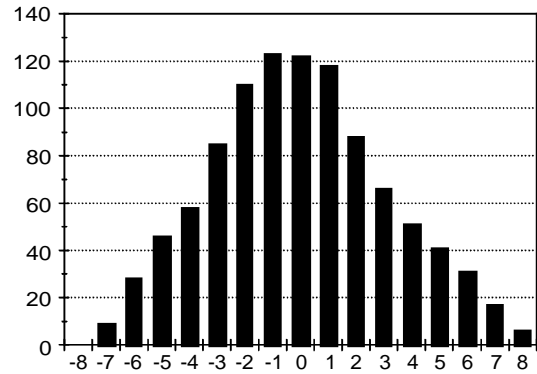

Figure 13. CS5520 Noise Histogram.

PIN DESCRIPTIONS

Modulator Diff. Voltage Ref +	MDRV+	1	24	SMODE	Serial Interface Mode
Modulator Diff. Voltage Ref -	MDRV-	2	23	XOUT	Crystal Out
Positive Analog Power	VA+	3	22	XIN	Crystal In
Negative Analog Power	VA-	4	21	VD-	Negative Digital Power
Analog Ground One	AGND1	5	20	VD+	Positive Digital Power
Analog In +	AIN+	6	19	DGND	Digital Ground
Analog In -	AIN-	7	18	SOD	Serial Output Data
Analog Ground Two	AGND2	8	17	SID	Serial Input Data
Voltage Ref In +	VREF+	9	16	SCLK	Serial Clock Input
Voltage Ref In -	VREF-	10	15	DRDY	Data Ready
Bridge Excite 2	BX2	11	14	CS	Chip Select
Bridge Excite 1	BX1	12	13	RST	Reset

Power Supply Connections

VD+ - Positive Digital Power, PIN 20.

Positive digital supply voltage. Nominally +5 volts.

VD- - Negative Digital Power, PIN 21.

Negative digital supply voltage. Nominally -5 volts.

DGND - Digital Ground, PIN 19.

Digital ground.

VA+ - Positive Analog Power, PIN 3.

Positive analog supply voltage. Nominally +5 volts.

VA- - Negative Analog Power, PIN 4.

Negative analog supply voltage. Nominally -5 volts.

AGND1, AGND2 - Analog Ground, PINS 5, 8.

Analog ground.

Clock Generator

XIN; XOUT - Crystal In; Crystal Out, Pins 22, 23

An internal gate is connected to these pins enabling the use of either a crystal or a ceramic resonator to provide the master clock for the device. Alternatively, an external (CMOS compatible) clock can be input to the XIN pin as the master clock for the device.

Digital Inputs

$\overline{\text{RST}}$ - Reset, PIN 13.

Reset pin initializes all calibration registers to a known condition and places the serial port into the command mode.

$\overline{\text{CS}}$ - Chip Select, PIN 14.

An input which can be enabled by an external device to gain control over the serial port. When this pin is high, SOD is in a high impedance state if SMODE = 0.

SCLK - Serial Data Clock, PIN 16.

A clock signal at this pin determines the output rate of the data from the SOD pin and the input data rate on the SID pin.

SID - Serial Input Data, PIN 17.

This pin is used for inputting command and configuration words or inputting calibration words. Data is input at a rate determined by SCLK. SID is in a don't care state when no data is being clocked in.

SMODE - Serial Interface Mode, PIN 24.

Selects the operating mode of the serial port. When low the serial port operates in the 5 or 4 wire interface mode. When high the chip will enter the 3 wire interface mode.

Analog Inputs

AIN+ and AIN- - Analog Inputs, PINS 6, 7.

The analog input signals from the transducer. These are true differential inputs.

VREF+ and VREF- - Voltage Reference Inputs, PINS 9,10.

These are the differential analog reference voltage inputs.

MDRV+ - Modulator Differential Voltage Reference, PIN 1.

Positive terminal of the internal differential voltage reference which can be tied to the positive supply (VA+) or ground (AGND).

MDRV- - Modulator Differential Voltage Reference, PIN 2.

This is the -3.75V modulator differential voltage reference output and can be used to generate an analog reference. Note this is with reference to the MDRV+ pin.

Digital Outputs

BX1 and BX2 - AC Bridge Excitation Signals, PINS 12, 11.

These can be buffered to drive the transducer or used as synchronizing signals for a transducer drive circuit. BX1 and BX2 are 0 to +5V signals.

$\overline{\text{DRDY}}$ - Data Ready, PIN 15.

$\overline{\text{DRDY}}$ goes low every 81,920 cycles of XIN (when in read conversion data mode) to indicate that new data has been placed in the output port. $\overline{\text{DRDY}}$ goes high when all the serial port data is clocked out, when the serial port is being updated with new data, when a calibration is in progress, or when the device is in SLEEP.

SOD - Serial Output Data, PIN 18.

Data from the serial port will be output from this pin at a rate determined by SCLK . The data will either be conversion data, or, calibration values, dependent upon the command word that has been previously input on the SID pin. The SOD pin furnishes a high impedance output state when not transmitting data (SMODE = 0).

ORDERING INFORMATION

Model	Package	Resolution	Linearity Error	Channels	Temperature
CS5516-AP	24-pin Plastic DIP	16 Bits	0.0030%	4	-40 to +85 °C
CS5516-AS	24-pin SOIC				
CS5516-ASZ (lead free)					
CS5520-BP	24-pin Plastic DIP	20 Bits	0.0015%		
CS5520-BS	24-pin SOIC				
CS5520-BSZ (lead free)					

ENVIRONMENTAL, MANUFACTURING, & HANDLING INFORMATION

Model Number	Peak Reflow Temp	MSL Rating*	Max Floor Life
CS5516-AP	260 °C	1	No Limit
CS5516-AS	240 °C	2	365 Days
CS5516-ASZ (lead free)	260 °C	3	7 Days
CS5520-BP	260 °C	1	No Limit
CS5520-BS	240 °C	2	365 Days
CS5520-BSZ (lead free)	260 °C	3	7 Days

* MSL (Moisture Sensitivity Level) as specified by IPC/JEDEC J-STD-020.

SPECIFICATION DEFINITIONS

Linearity Error

The deviation of a code from a straight line which extends between two fixed points on the A/D converter transfer function. In unipolar mode, the straight line extends from one point located $\frac{1}{2}$ LSB below the first code transition, one count above all zeros; to the second point located $\frac{1}{2}$ LSB beyond the code transition to all ones. In bipolar mode, the straight line extends from one point located $\frac{1}{2}$ LSB beyond the code transition to all ones, passing through a point $\frac{1}{2}$ LSB below code 8000(H) (16-bit); 80000(H) (20-bit); extending to beyond negative full scale. Units are in percent of full-scale.

Differential Nonlinearity

The deviation of a code's width from the ideal width. Units in LSBs.

Full Scale Error

The deviation of the last code transition from the ideal $\{[(VREF+)-(VREF-)]-\frac{3}{2}$ LSB}. Units are in LSBs.

Unipolar Offset

The deviation of the first code transition from the ideal ($\frac{1}{2}$ LSB above AGND) when in unipolar mode (BP/UP low). Units are in LSBs.

Bipolar Offset

The deviation of the mid-scale transition (011...111 to 100...000) from the ideal ($\frac{1}{2}$ LSB below AGND) when in bipolar mode (BP/UP high). Units are in LSBs.

Contacting Cirrus Logic Support

For all product questions and inquiries contact a Cirrus Logic Sales Representative.

To find the one nearest to you go to www.cirrus.com

IMPORTANT NOTICE

Cirrus Logic, Inc. and its subsidiaries ("Cirrus") believe that the information contained in this document is accurate and reliable. However, the information is subject to change without notice and is provided "AS IS" without warranty of any kind (express or implied). Customers are advised to obtain the latest version of relevant information to verify, before placing orders, that information being relied on is current and complete. All products are sold subject to the terms and conditions of sale supplied at the time of order acknowledgment, including those pertaining to warranty, indemnification, and limitation of liability. No responsibility is assumed by Cirrus for the use of this information, including use of this information as the basis for manufacture or sale of any items, or for infringement of patents or other rights of third parties. This document is the property of Cirrus and by furnishing this information, Cirrus grants no license, express or implied under any patents, mask work rights, copyrights, trademarks, trade secrets or other intellectual property rights. Cirrus owns the copyrights associated with the information contained herein and gives consent for copies to be made of the information only for use within your organization with respect to Cirrus integrated circuits or other products of Cirrus. This consent does not extend to other copying such as copying for general distribution, advertising or promotional purposes, or for creating any work for resale.

CERTAIN APPLICATIONS USING SEMICONDUCTOR PRODUCTS MAY INVOLVE POTENTIAL RISKS OF DEATH, PERSONAL INJURY, OR SEVERE PROPERTY OR ENVIRONMENTAL DAMAGE ("CRITICAL APPLICATIONS"). CIRRUS PRODUCTS ARE NOT DESIGNED, AUTHORIZED OR WARRANTED FOR USE IN AIRCRAFT SYSTEMS, MILITARY APPLICATIONS, PRODUCTS SURGICALLY IMPLANTED INTO THE BODY, AUTOMOTIVE SAFETY OR SECURITY DEVICES, LIFE SUPPORT PRODUCTS OR OTHER CRITICAL APPLICATIONS. INCLUSION OF CIRRUS PRODUCTS IN SUCH APPLICATIONS IS UNDERSTOOD TO BE FULLY AT THE CUSTOMER'S RISK AND CIRRUS DISCLAIMS AND MAKES NO WARRANTY, EXPRESS, STATUTORY OR IMPLIED, INCLUDING THE IMPLIED WARRANTIES OF MERCHANTABILITY AND FITNESS FOR PARTICULAR PURPOSE, WITH REGARD TO ANY CIRRUS PRODUCT THAT IS USED IN SUCH A MANNER. IF THE CUSTOMER OR CUSTOMER'S CUSTOMER USES OR PERMITS THE USE OF CIRRUS PRODUCTS IN CRITICAL APPLICATIONS, CUSTOMER AGREES, BY SUCH USE, TO FULLY INDEMNIFY CIRRUS, ITS OFFICERS, DIRECTORS, EMPLOYEES, DISTRIBUTORS AND OTHER AGENTS FROM ANY AND ALL LIABILITY, INCLUDING ATTORNEYS' FEES AND COSTS, THAT MAY RESULT FROM OR ARISE IN CONNECTION WITH THESE USES.

Cirrus Logic, Cirrus, and the Cirrus Logic logo designs are trademarks of Cirrus Logic, Inc. All other brand and product names in this document may be trademarks or service marks of their respective owners.

CS5516 & CS5520 ADC Evaluation Boards

Features

- On-board microcontroller
- RS232 Serial Communications with host PC
- Supports either AC or DC bridge drive
- On-board bridge driver
- Supports ratiometric or absolute measurements
- Evaluation software included

Description

The CDB5516 and CDB5520 provide quick and easy evaluation of the CS5516 and CS5520 bridge transducer A/D converters. Direct connection of the bridge to the evaluation board is provided.

The board also contains a microcontroller, with firmware which allows the board to be controlled via simple serial commands, using the RS232 communications port of a PC.

ORDERING INFORMATION

CDB5516	Evaluation Board
CDB5520	Evaluation Board

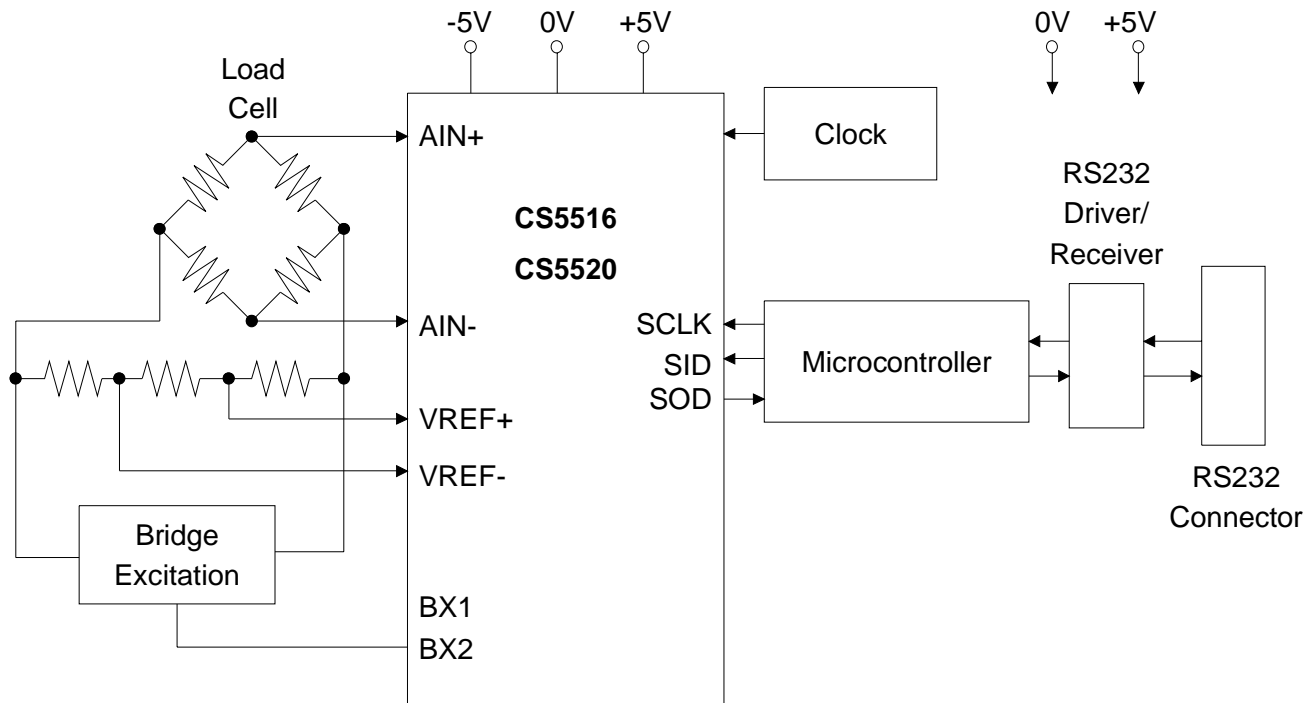

Introduction

The CDB5516/20 evaluation board provides a means of testing the CS5516 and CS5520 bridge transducer A/D converters. The board is designed to be interfaced to a PC-compatible computer via an RS-232 port. Software is supplied with the board which provides control of all registers in the CS5516 or the CS5520.

The board is configured to be operated from +5 and -5 volt power supplies. A bridge transducer or a bridge transducer simulator is required if the board is to be evaluated in the ratiometric operating mode.

Evaluation Board Overview

Figure 1 illustrates the schematic of the bridge driver and A/D converter portion of the circuit board. The converter operates from a 4 MHz crystal. This results in the converter outputting conversion words at a 50 Sps rate. The board comes configured to be interfaced to a bridge transducer via the 6-pin transducer terminal block. The sense lines on the transducer terminal block provide the reference voltage for the converter.

For absolute measurements, the user can connect either an external reference voltage (up to 3.8 volts) to the reference terminal block or connect the on-board 2.5 volt LT1019 reference as the voltage reference for the converter.

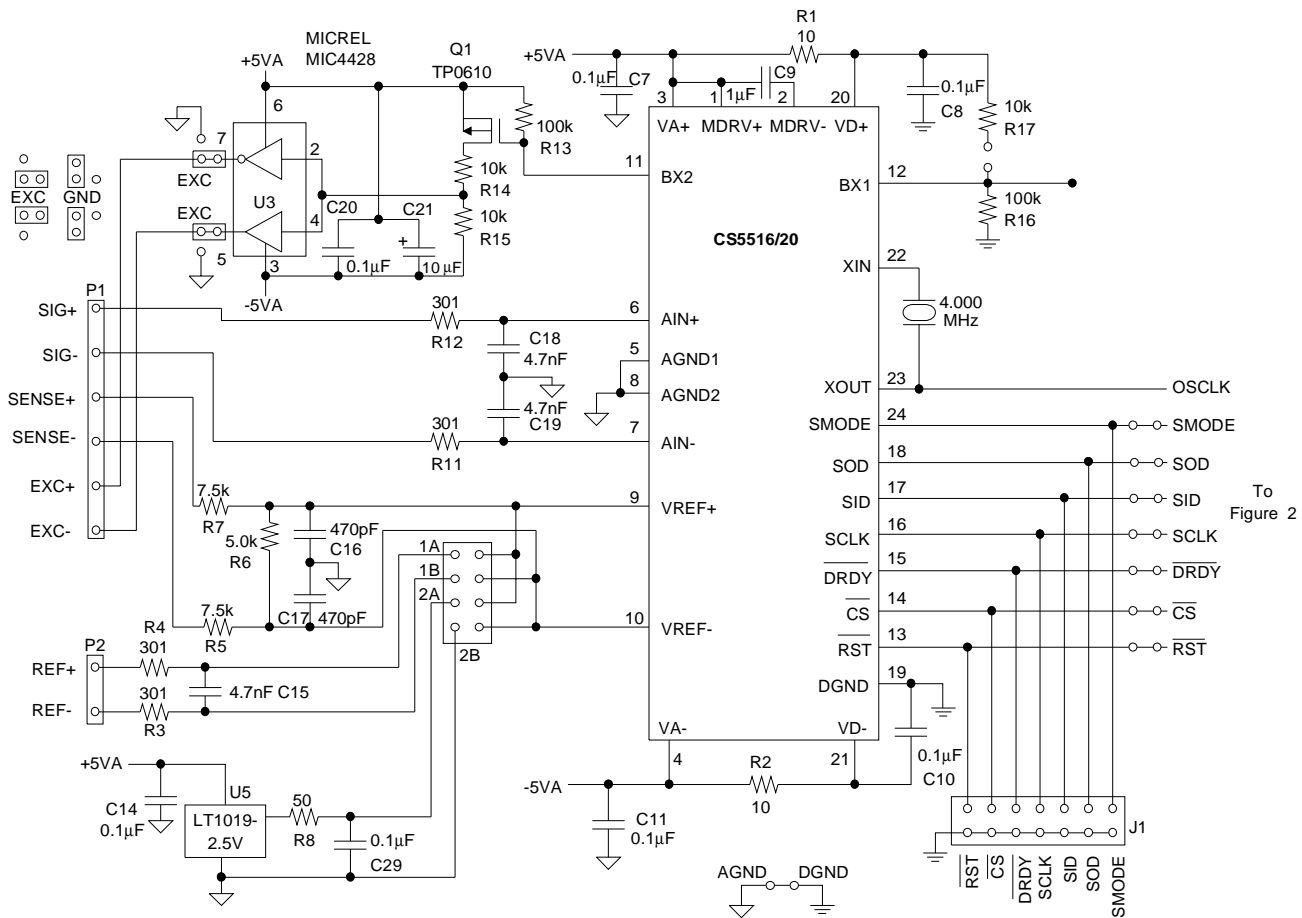

Figure 1. Bridge Driver and A/D Converter

A bridge driver, composed of a Siliconix TP0610 transistor and a Micrel MIC4428 dual CMOS driver, is provided which allows the BX2 output from the CS5516 or CS5520 to provide either dc or ac excitation to the bridge.

The digital interface pins of the A/D converter connect to the microcontroller, or alternatively, these connections can be cut, or the on-board microcontroller can be removed, and the user's own microcontroller can be interfaced to J1 header connector.

Figure 2 illustrates the Motorola 68HC705C8 microcontroller which reads or writes data into the A/D converter and communicates with the

PC-compatible computer via the RS-232 interface. The microcontroller derives its 4 MHz clock from the A/D converter clock. The microcontroller is configured to communicate over the RS-232 link at 4800 baud, no parity, 8-bit data, and 1 stop bit. A Motorola MC145407 RS-232 interface chip is used to send and receive data to the PC-compatible computer via the 25-pin Sub-D connector.

Table 1 lists the commands sent to the microcontroller to write to or to read from the registers in the A/D converter. If software other than that provided with the evaluation board is used, the format of the data transmitted over the RS232 line is as follow: Write commands are com-

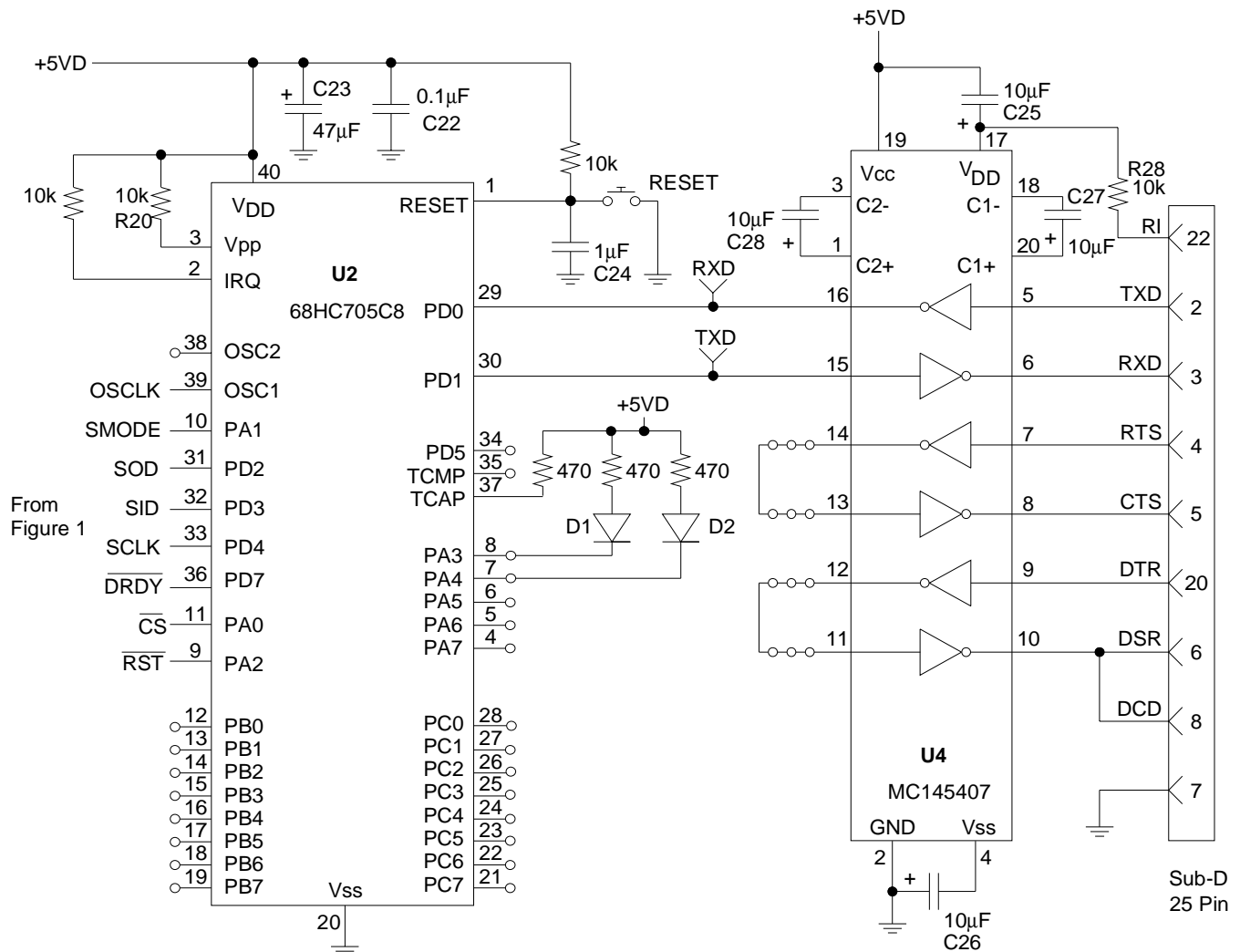

Figure 2. Microcontroller and RS-232 Interface

Register	Read	Write
Conversion Data Register	50(H)	
Configuration Register	51(H)	D1(H)
DAC Register	53(H)	D3(H)
Gain Register	52(H)	D2(H)
AIN Ratiometric Offset Register	54(H)	D4(H)
AIN Nonratiometric Offset Register	55(H)	D5(H)
VREF Nonratiometric Offset Register	56(H)	D6(H)

Table 1. Microcontroller commands via RS-232

posed of one byte for command which is transmitted with its LSB first. The command is followed by three data bytes which make up the 24-bit word to be written to the selected register of the A/D converter. The three bytes are transmitted lowest order byte first (bits 7 - 0) with the LSB of the byte transmitted first.

Figure 3 illustrates the power supply connections to the evaluation board. Voltages of +5 and -5 analog and +5 digital are required.

Using the Evaluation Board

Prior to using the board to evaluate the CS5516 or CS5520 A/D converter, a good understanding of the full potential of the converter is necessary. It is recommended that the CS5516/CS5520 device data sheet be thoroughly read prior to attempting to use the evaluation board. The CS5516 or CS5520 bridge transducer A/D converter actually contains two A/D converters.

One of the converters is used to convert the VREF voltage input, and the other is used to convert the AIN signal input. Both converters utilize an on-chip voltage reference to perform conversions of their respective inputs. Since both converters use the same reference they track one another. The digital processing logic of the A/D converter depends on the presence of both signals to properly compute a digital output word. If the evaluation board is configured for bridge measurement, and no bridge (load cell or simulator) is connected to the bridge transducer terminal block, the converter will output a code of zero because no reference voltage is present between the VREF+ and VREF- pins.

The span of the AIN input signal is determined by a combination of the instrumentation amplifier gain (X25), the programmable gain amplifier (PGA) gain, the magnitude of the voltage between the VREF+ and VREF- input pins, and the calibration words for gain and offset. For ex-

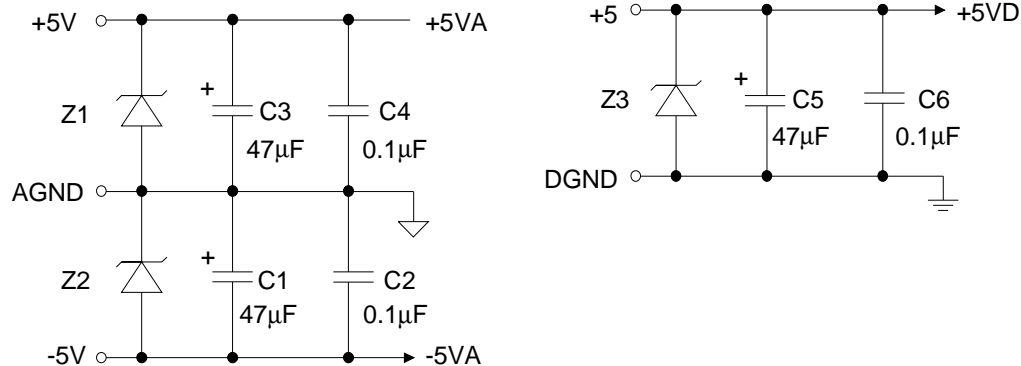

Figure 3. Power Supplies

ample, the board comes with a set of precision resistors which divide the excitation supply (nominally 10 volts total) down to 2.5 volts between the VREF+ and VREF- input pins. This sets the nominal full scale voltage into the A/D converter. The input span of the instrumentation amplifier can be calculated to by knowing the PGA gain setting, and that the gain of the instrumentation amplifier is X25. If the PGA is set for a gain of 8, then the input span to the instrumentation amplifier will be 2.5 volts (VREF+ - VREF-) divided by 8×25 , or $2.5/(200) = 12.5$ millivolt nominal in unipolar mode. The device can be then calibrated with an input voltage which is as low as 20% less than nominal or up to 20% greater than nominal. Therefore, with this VREF+- VREF- voltage (2.5 volts) and a PGA gain of 8 the input span can be calibrated to handle a span from a low of 10 mV to a high of 15 mV. To modify the input span the user can either change the PGA gain or modify the resistor divider on the bridge sense voltage to yield an appropriate value in the range of 2.0 to 3.8 volts. This makes the A/D converter quite flex-

ible in handling load cells with different output levels. Whenever configured as a bridge transducer device, the CS5516 or the CS5520 A/D converter operates in ratiometric measurement mode. Figures 4 and 5 illustrate how to connect 4-wire and 6-wire bridge transducers to the board.

Alternatively, the CS5516 or CS5520 can be configured for absolute measurement if a precision reference voltage is supplied between the VREF+ and VREF- pins of the A/D converter. The board can be modified to accept a reference into the voltage reference terminal block; or the on-board LT1019-2.5 volt reference can be used as the reference voltage for the A/D converter. To use either of these inputs will require that jumper wires be soldered in either 1A-1B to select the external voltage reference input, or 2A-2B to select the on-board LT1019-2.5. Figure 6 illustrates the connection of an external voltage reference to the evaluation board for absolute voltage measurement applications. To achieve an accurate reference voltage resistor R6

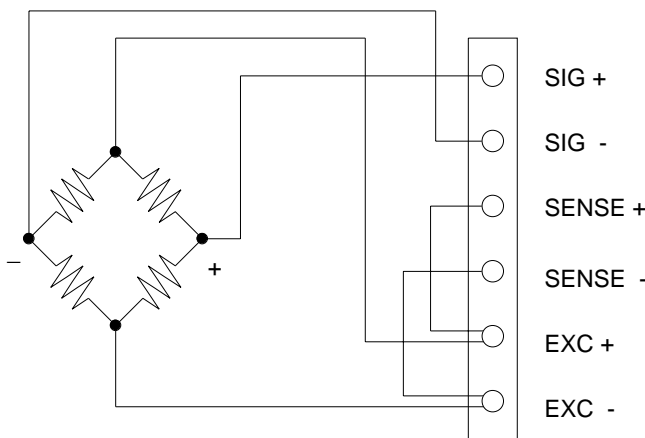

Figure 4. 4-Wire Bridge Connections

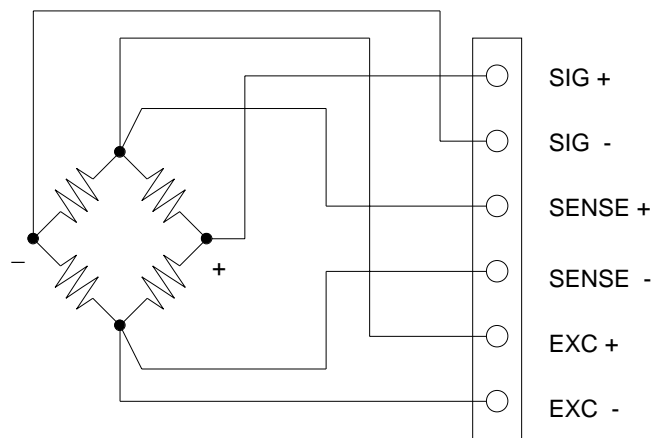

Figure 5. 6-Wire Bridge Connections

must be removed from between the +VREF and -VREF pins. It may be desirable to also remove R5, R7, C16, and C17 in some applications.

Calibrating the A/D Converter

As explained in the CS5516/CS5520 data sheet, the order in which the calibration steps are performed are important. If one chooses to use the non-ratiometric calibration capabilities of the converter, the non-ratiometric errors of the VREF and AIN channels should be calibrated first. The non-ratiometric calibration steps can be performed at the same time. Before the non-ratiometric offset calibration is initiated, the bridge should be grounded. This can be achieved on the evaluation board by moving the two jumpers at the output of the MIC4428 driver to the GND position (see Figure 1). The converter is then instructed via the configuration register bits to perform the non-ratiometric calibration steps. Once the non-ratiometric calibrations are completed, jumpers at the output of the

MIC4428 driver should be returned to the EXC position.

After the non-ratiometric calibration steps are performed, the AIN ratiometric offset is then calibrated. With "zero weight" on the load cell, the converter is instructed via the configuration register to perform the AIN ratiometric offset calibration step. Finally, with "full scale weight" on the load cell, the converter is instructed to perform the gain calibration step.

The converter is then ready to perform conversions.

Software

The evaluation board comes with software and a RS-232 cable to interface the board to a RS-232 port of a PC-compatible computer. The software diskette contains a README.TXT file which explains its operation.

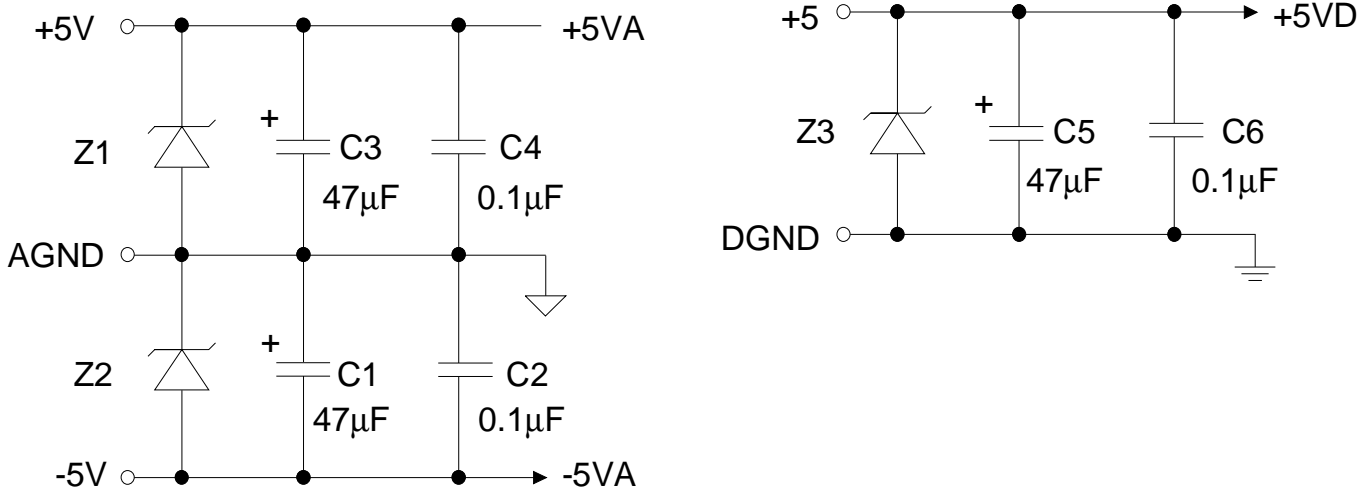

Figure 6. Using Off-board Voltage Reference

Figure 7 illustrates the software supplied with the CDB5516/CDB5520 evaluation board. The software allows the user to manipulate the registers of the converter and perform calibrations and conversions. It decodes the status of the configuration register and indicates the gain register scale factor. The software enables the user to collect data to a file, average samples and compute the average and standard deviation of the samples which have been collected.

CS5520	COM2	Displayed data AVE=50	Data to file DEC=50		CONFIGURATION STATUS
REGISTERS	BINARY	DEC	HEX		
1	GAIN	100011011101111001000100	-7479740	8dde44	23-20 DAC =-000
2	DAC	100001100100000000000000			19 EXC = INT
3	AIN_R_OFF	000000000000110100011010	3354	d1a	18 17 F1F0 =XIN/4096
4	AIN_N_OFF	111111111111000000101011	-4053	fff02b	15 14 G1G0 = 4 X 25
5	UREF_N_OFF	111111111111010101011010	-2726	fff55a	13 U/B = Bipolar
6	CONFIG REG	100001100100000000000000	-7979008	864000	10 EC = off
					7 U_NR_D = off
					6 A_NR_D = off
					5 A_R_D = off
					4 A_G = off
					GAIN REG =1.108346

RC	RD	WR	SD	SA	CT	QT

READ conversion DATA register					
	HIGH	LOW	DIFF	AVE	STD DEV
	6	-9	15	-1	3.4092
	5	-9	14	-2	3.0999
	10	-7	17	0	3.6549
	8	-10	18	-1	3.6767
	5	-10	15	-2	2.9681
	6	-8	14	-2	3.2366
	7	-4	11	0	2.5519
	6	-8	14	-2	3.2205

Figure 7. Screen for the CDB5516/CDB5520 Evaluation Board Software

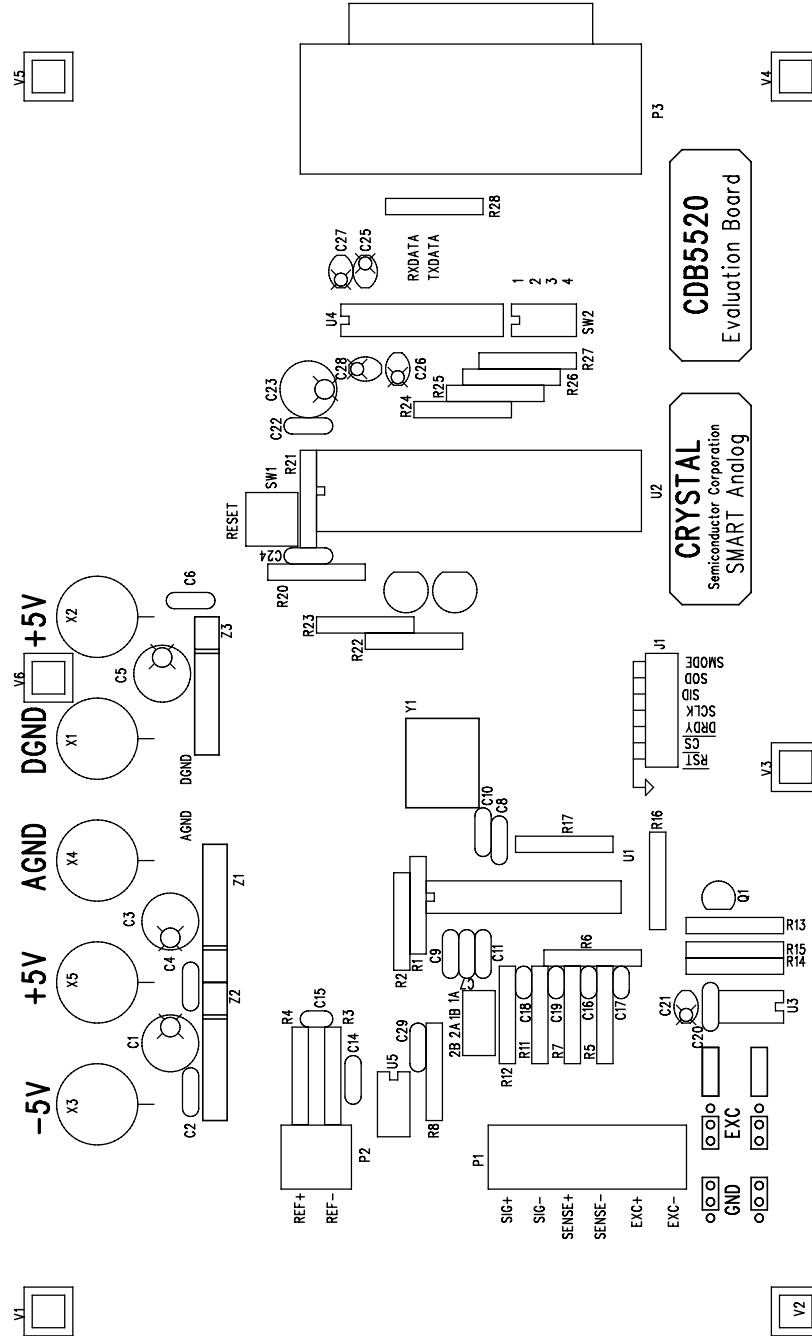

Figure 8. CDB5520 Silkscreen

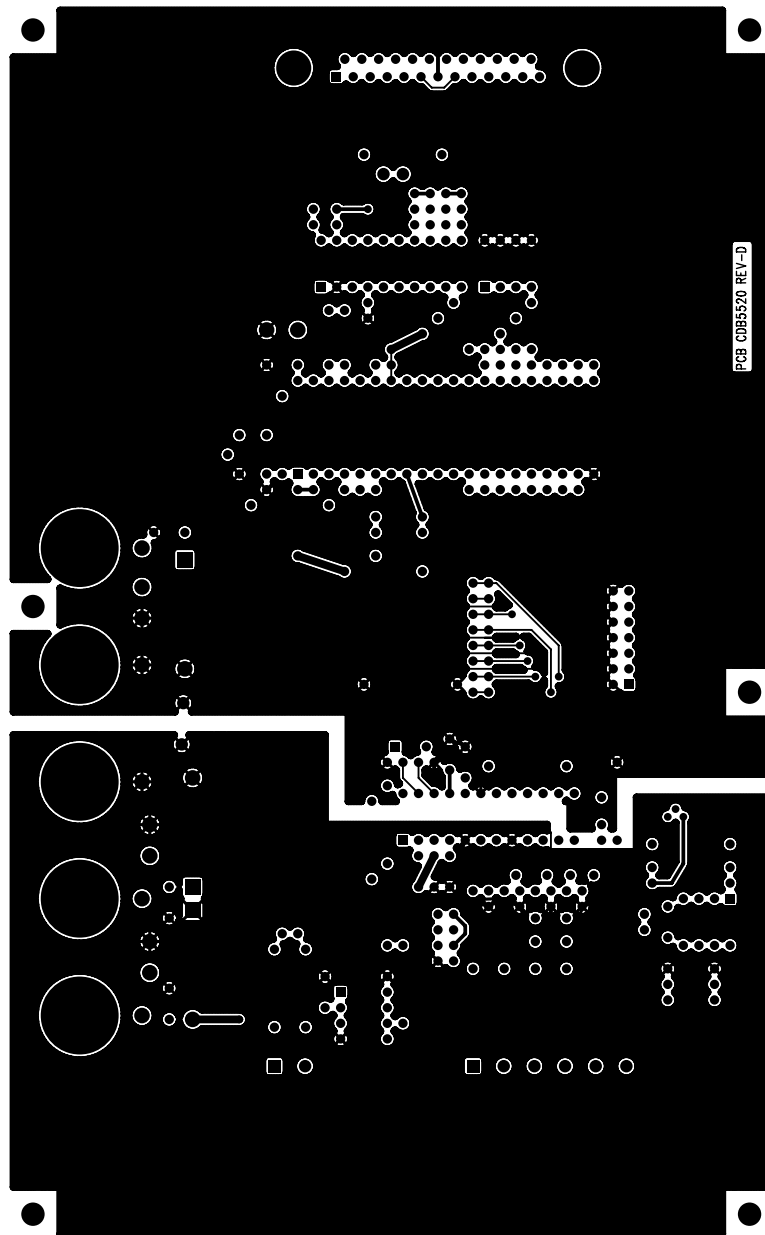

Figure 9. CDB5520 Top Ground Plane

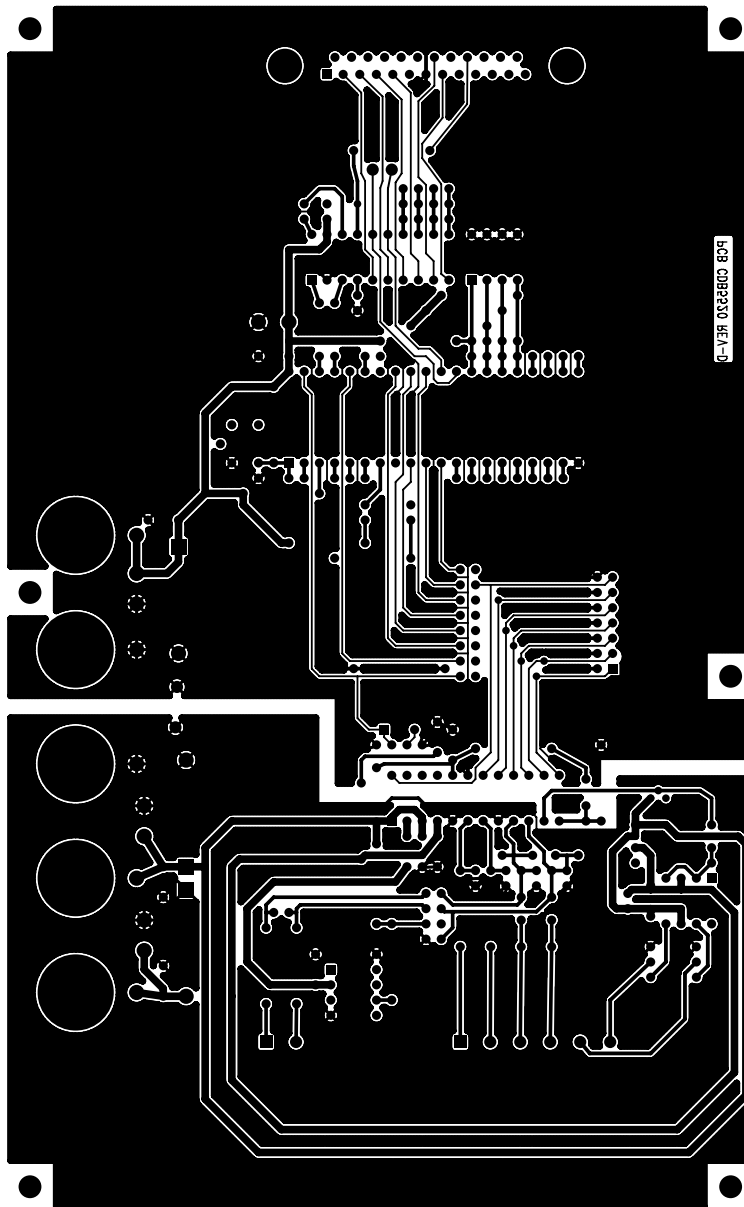

Figure 10. CDB5520 Solder Side Trace Layer

Contacting Cirrus Logic Support

For all product questions and inquiries contact a Cirrus Logic Sales Representative.

To find the one nearest to you go to www.cirrus.com

IMPORTANT NOTICE

Cirrus Logic, Inc. and its subsidiaries ("Cirrus") believe that the information contained in this document is accurate and reliable. However, the information is subject to change without notice and is provided "AS IS" without warranty of any kind (express or implied). Customers are advised to obtain the latest version of relevant information to verify, before placing orders, that information being relied on is current and complete. All products are sold subject to the terms and conditions of sale supplied at the time of order acknowledgment, including those pertaining to warranty, indemnification, and limitation of liability. No responsibility is assumed by Cirrus for the use of this information, including use of this information as the basis for manufacture or sale of any items, or for infringement of patents or other rights of third parties. This document is the property of Cirrus and by furnishing this information, Cirrus grants no license, express or implied under any patents, mask work rights, copyrights, trademarks, trade secrets or other intellectual property rights. Cirrus owns the copyrights associated with the information contained herein and gives consent for copies to be made of the information only for use within your organization with respect to Cirrus integrated circuits or other products of Cirrus. This consent does not extend to other copying such as copying for general distribution, advertising or promotional purposes, or for creating any work for resale.

CERTAIN APPLICATIONS USING SEMICONDUCTOR PRODUCTS MAY INVOLVE POTENTIAL RISKS OF DEATH, PERSONAL INJURY, OR SEVERE PROPERTY OR ENVIRONMENTAL DAMAGE ("CRITICAL APPLICATIONS"). CIRRUS PRODUCTS ARE NOT DESIGNED, AUTHORIZED OR WARRANTED FOR USE IN AIRCRAFT SYSTEMS, MILITARY APPLICATIONS, PRODUCTS SURGICALLY IMPLANTED INTO THE BODY, AUTOMOTIVE SAFETY OR SECURITY DEVICES, LIFE SUPPORT PRODUCTS OR OTHER CRITICAL APPLICATIONS. INCLUSION OF CIRRUS PRODUCTS IN SUCH APPLICATIONS IS UNDERSTOOD TO BE FULLY AT THE CUSTOMER'S RISK AND CIRRUS DISCLAIMS AND MAKES NO WARRANTY, EXPRESS, STATUTORY OR IMPLIED, INCLUDING THE IMPLIED WARRANTIES OF MERCHANTABILITY AND FITNESS FOR PARTICULAR PURPOSE, WITH REGARD TO ANY CIRRUS PRODUCT THAT IS USED IN SUCH A MANNER. IF THE CUSTOMER OR CUSTOMER'S CUSTOMER USES OR PERMITS THE USE OF CIRRUS PRODUCTS IN CRITICAL APPLICATIONS, CUSTOMER AGREES, BY SUCH USE, TO FULLY INDEMNIFY CIRRUS, ITS OFFICERS, DIRECTORS, EMPLOYEES, DISTRIBUTORS AND OTHER AGENTS FROM ANY AND ALL LIABILITY, INCLUDING ATTORNEYS' FEES AND COSTS, THAT MAY RESULT FROM OR ARISE IN CONNECTION WITH THESE USES.

Cirrus Logic, Cirrus, and the Cirrus Logic logo designs are trademarks of Cirrus Logic, Inc. All other brand and product names in this document may be trademarks or service marks of their respective owners.

Looking for pricing, stock, or lifecycle information?

Click below to explore more details on WIN SOURCE:

 [View CS5516-ASZ on WIN SOURCE](#)

 [Cirrus Logic Inc. Information](#)

Optimize Your Supply Chain with WIN SOURCE Solutions

-  Global Sourcing Solution
-  Obsolete Management
-  Cost Control Management
-  Shortage Management
-  Alternative Solution
-  Excess Inventory Management