



**THE DATASHEET OF  
CY22391LFXC-02T**



# Factory Programmable, Quad PLL Clock Generator with VCXO

## Features

- Fully integrated phase-locked loops (PLLs)
- Small quad flat no-leads (QFN) package option
  - 40% smaller than 20-pin TSSOP
  - 22% smaller than 16-pin TSSOP
- Selectable output frequency
- Programmable output frequencies
- Output frequency range:
  - 1 MHz to 166 MHz
- Input frequency range:
  - Crystal: 10 MHz to 30 MHz
  - External reference: 1 MHz to 100 MHz
- Analog voltage-control crystal oscillator (VCXO)
- 16-/20-pin TSSOP and 32-pin QFN packages
- 3.3-V operation with 2.5-V output buffer option

## Benefits

- Meets most digital set top box, DVD recorder, and DTV application requirements
- Multiple high-performance PLLs allow synthesis of unrelated frequencies
- Integration eliminates the need for external loop filter components
- Meets critical timing requirements in complex system designs
- Enables application compatibility
- Complete VCXO solution with  $\pm 120$  ppm (typical pull range)

## Functional Description

For a complete list of related documentation, click [here](#).

## Logic Block Diagram

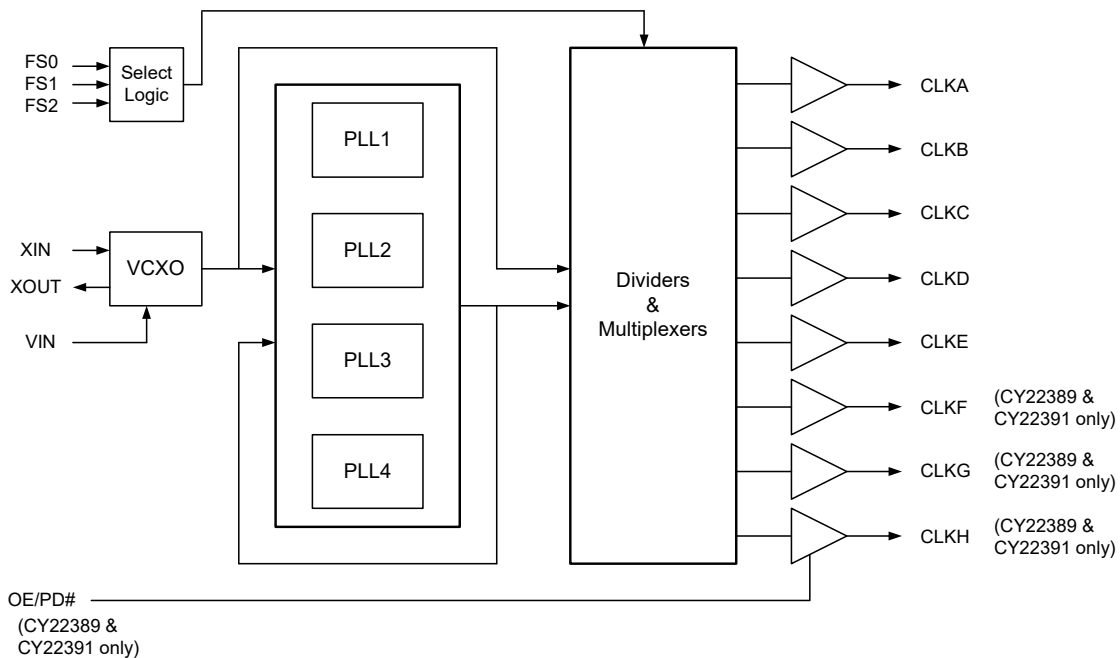

## Contents

<b>Pinouts</b> .....	<b>3</b>	<b>Ordering Information</b> .....	<b>11</b>
<b>Pin Definitions</b> .....	<b>4</b>	Possible Configurations .....	11
<b>General Description</b> .....	<b>5</b>	Ordering Code Definitions .....	11
Factory-Programmable CY22388/89/91 .....	5	<b>Package Drawing and Dimensions</b> .....	<b>12</b>
<b>PLLs</b> .....	<b>5</b>	<b>Acronyms</b> .....	<b>14</b>
<b>Frequency Select Pin Operation</b> .....	<b>5</b>	<b>Document Conventions</b> .....	<b>14</b>
<b>Analog VCXO</b> .....	<b>6</b>	Units of Measure .....	14
<b>VCXO Profile</b> .....	<b>6</b>	<b>Document History Page</b> .....	<b>15</b>
<b>Absolute Maximum Conditions</b> .....	<b>7</b>	<b>Sales, Solutions, and Legal Information</b> .....	<b>17</b>
<b>Pullable Crystal Specifications</b> .....	<b>7</b>	Worldwide Sales and Design Support .....	17
<b>Operating Conditions</b> .....	<b>7</b>	Products .....	17
<b>DC Parameters</b> .....	<b>8</b>	PSoC® Solutions .....	17
<b>AC Parameters</b> .....	<b>9</b>	Cypress Developer Community .....	17
<b>Test and Measurement</b> .....	<b>9</b>	Technical Support .....	17
<b>Voltage and Timing Definitions</b> .....	<b>10</b>		

## Pinouts

**Figure 1. 16-pin TSSOP pinout**

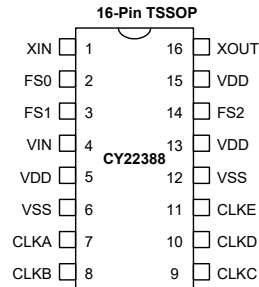

**Figure 2. 20-pin TSSOP pinout**

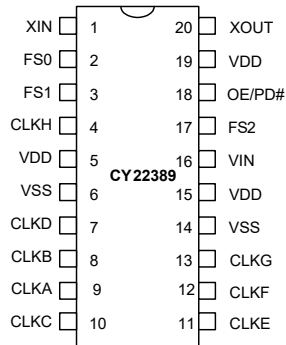

**Figure 3. 32-pin QFN pinout**

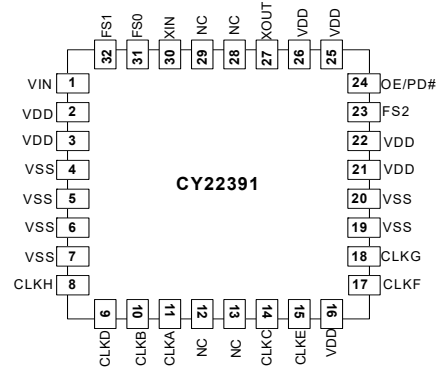



## Pin Definitions

Pin Name	Pin Number			Pin Description
	16-pin TSSOP	20-pin TSSOP	32-pin QFN	
XIN	1	1	30	Crystal input or reference clock input
XOUT	16	20	27	Crystal output (No connect if external clock is used)
CLKA	7	9	11	Clock output
CLKB	8	8	10	Clock output
CLKC	9	10	14	Clock output
CLKD	10	7	9	Clock output
CLKE	11	11	15	Clock output
CLKF	n/a	12	17	Clock output
CLKG	n/a	13	18	Clock output
CLKH	n/a	4	8	Clock output
FS0	2	2	31	Frequency select 0
FS1	3	3	32	Frequency select 1
FS2	14	17	23	Frequency select 2
OE/PD#	n/a	18	24	Programmable control pin: Output enable (active-high) or power-down (active-low)
VIN	4	16	1	Analog control input for VCXO
VDD	5, 13, 15	5, 15, 19	2, 3, 16, 21, 22, 25, 26	Voltage supply
VSS	6, 12	6, 14	4, 5, 6, 7, 19, 20	Ground
NC	N/A	N/A	12, 13, 28, 29	No connect.

## General Description

The CY22388 family of devices has an analog VCXO, four PLLs, up to eight clock outputs and frequency selection capabilities. The frequency selects do not modify any PLL frequency. Instead they allow the user to choose among eight different output divider selections depending on the clock and package configuration. This is illustrated in [Frequency Select Pin Operation](#).

There is one programmable OE/PD#. The OE/PD# pin can be programmed as either an output enable pin or a power-down pin. The OE function can be programmed to disable a selected set of outputs when low, leaving the remaining outputs running. Full-chip power-down disables all outputs and the PLLs and most of the active circuitry when low.

### Factory-Programmable CY22388/89/91

Factory programming is available for high- or low-volume manufacturing by Cypress. All requests must be submitted to the local Cypress field application engineer (FAE) or sales representative. After the request is processed, you receive a new part number, samples, and datasheet with the programmed values. This part number is used for additional sample requests and production orders.

## PLLs

The advantage of having four PLLs is that a single device can generate up to four independent frequencies from a single crystal. Generally a design may require up to four oscillators to accomplish what could be done with a single CY22388.

Each PLL is independent and can be configured to generate a voltage-controlled oscillator (VCO) frequency between 62.5 MHz and 250 MHz. Each PLL can then, in turn, be divided down with post dividers to generate the clock output frequency of the user's choice. The output divider allows each clock output to be divided by 1, 2, 3, 4, 5, 6, 8, 9, 10, 12 or 15. The PLL maximum is reduced to 166 MHz in 'divide by 1' mode due to output buffer limitations.

Outputs that allow frequency switching perform a glitch-free transition. A glitch is defined as a high- or low-time shorter than half the smaller of the two periods being switched between. Extended low time (even many cycles in duration) is acceptable.

Selected clock outputs are capable of being powered off a separate 2.5-V supply. This allows for driving lower voltage swing inputs. The CY22388/89/91 device still requires 3.3 V to power the oscillator and all other internal PLL circuitry. For the 2.5-V output option, refer to the [CY22388 application note](#). Selected clocks and pinout diagrams are explained in this application note.

Clock D can obtain its output from either the reference source or PLL1/N1 with N1 being defined as the output divider for PLL1. Clock H is defined as a copy of clock D. Clock D is only available from PLL1/N1 on the 16-pin package.

For CY22388, CLKB and CLKC have related frequencies. For CY22389 and CY22391, CLKD and CLKF have related frequencies, CLKA and CLKB have related frequencies, and CLKC and CLKE have related frequencies. Related frequencies come from the same PLL but can have different divider values.

To minimize parts per million (PPM) error on the clock outputs, you must choose a crystal reference frequency that is a common multiple of the desired PLL frequencies. While this is the ideal situation, this is not always the case and the PLLs have high-resolution counters internally to help minimize frequency deviation from the desired frequency.

PLL VCO frequencies are generated by the following equation:  

$$F_{VCO} = F_{REF} \times (P / Q)$$

where  $F_{REF}$  is the reference input frequency, P is the PLL feedback divider, and Q is the reference input divider.

A PLL is a feedback system where the VCO frequency divided by P and reference frequency divided by Q are constantly being compared and the VCO frequency is adjusted to achieve a locked state. [Figure 4](#) is a simplified drawing of a PLL.

**Figure 4. PLL system**

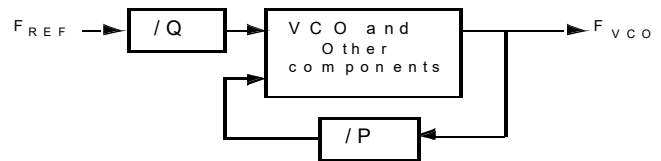

## Frequency Select Pin Operation

**Table 1. CY22388 16-pin TSSOP**

Output Signal	Frequency Selection Lines
CLK A	FS2, FS1, FS0
CLK B	FS1, FS0
CLK C & CLK D	S0
CLK E	FIXED

**Table 2. CY22389 20-pin TSSOP**

Output Signal	Frequency Selection Lines
CLK A	FS2, FS1, FS0
CLK B & CLK C	FS1, FS0
CLK D, CLK E, & CLK F	FS0
CLK G	FIXED
CLK H	COPY OF CLK D

**Table 3. CY22391 32-pin QFN**

Output Signal	Frequency Selection Lines
CLK A	FS2, FS1, FS0
CLK B & CLK C	FS1, FS0
CLK D, CLK E, & CLK F	FS0
CLK G	FIXED
CLK H	COPY OF CLK D

## Analog VCXO

There are three programmable reference operating modes for the CY22388, CY22389, and CY22391 family of devices. The first mode uses an external pullable crystal and incorporates an internal analog VCXO.

The second mode configures the internal crystal oscillator to accept an external driven reference source from 1 to 100 MHz. The input capacitance on the XIN PIN when driven in this mode is 15 pF.

The third mode disables the VCXO input control and sets the internal oscillator to a fixed frequency operation. The load capacitance seen by the external crystal when connected to PINS XIN and XOUT is equal to 12 pF.

One of the key components in the CY22388, CY22389, and CY22391 family of devices is the analog VCXO. The VCXO is used to 'pull' the reference crystal higher or lower to lock the system frequency to an external source. This is ideal for applications where the output frequency needs to track along with an external reference frequency that is constantly shifting.

The VCXO is completely analog, so there is infinite resolution on the VCXO pull curve. The analog to digital converter steps that are normally associated with a digital VCXO input is not present in this device. A special pullable crystal must be used in order to

have adequate VCXO pull range. Pullable crystal specifications are included in this datasheet.

## VCXO Profile

Figure 5 shows an example of what a VCXO profile looks like. The analog voltage input is on the X-axis and the PPM range is on the Y-axis. An increase in the VCXO input voltage results in a corresponding increase in the output frequency. This has the effect of moving the PPM from a negative to positive offset.

**Figure 5. VCXO Profile**

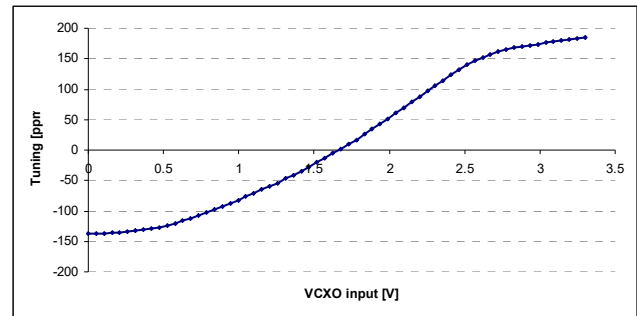



## Absolute Maximum Conditions

Parameter	Description	Condition	Min	Max	Unit
$V_{DD}/AV_{DD}/V_{DDL}$	Core supply voltage		-0.5	4.6	V
$V_{IN}$	Input voltage	Relative to $V_{SS}$	-0.5	$V_{DD} + 0.5$	VDC
$T_S$	Temperature, Storage	Non-Functional	-65	125	°C
$ESD_{HBM}$	Electrostatic discharge (ESD) protection (human body model)	MIL-STD-883, Method 3015	2000	-	V
UL-94	Flammability rating	V-0 at 1/8 in.	-	10	ppm
MSL	Moisture sensitivity level	All packages	3		-

## Pullable Crystal Specifications

Parameter <sup>[1, 2]</sup>	Description	Comments	Min	Typ	Max	Unit
$F_{NOM}$	13.5-MHz and 27-MHz crystal AT-Cut	Parallel resonance, fundamental mode	See Note 2			
$C_{LNOM}$	Nominal load capacitance	Order crystal at one specific $C_{LNOM}$ 0 ppm	11.4	12	12.6	pF
$R_1$	Equivalent series resistance (ESR)	Fundamental mode (CL = Series)	-	-	40	$\Omega$
DL	Crystal drive level	Nominal $V_{DD}$ at 25 °C over $\pm 120$ ppm pull range	-	-	300	$\mu W$
$C_0^{[3]}$	Crystal shunt capacitance		1.5	3	4.0	pF
$C_1^{[3]}$	Crystal motional capacitance		12	14	16.8	fF
$F_{3SEPHI}^{[2]}$	Third overtone separation from $3 \times F_{NOM}$	Mechanical third (high side of $3 \times F_{NOM}$ )	240	-	-	ppm
$F_{3SEPLO}^{[2]}$	Third overtone separation from $3 \times F_{NOM}$	Mechanical third (low side of $3 \times F_{NOM}$ )	-	-	-120	ppm

## Operating Conditions

Parameter	Description	Min	Typ	Max	Unit
$V_{DD}/AV_{DD}/V_{DDL}$	Operating voltage	3.0	3.3	3.6	V
$T_A$	Ambient temperature	-10	-	70	°C
$C_{LOAD}$	Maximum load capacitance	-	-	15	pF
$t_{PU}$	Power-up time for all $V_{DD}$ s reach minimum specified voltage (power ramps must be monotonic)	0.05	-	500	ms

### Notes

1. Device operates to the following specs, which are guaranteed by design.
2. Refer to online software for a list of approved crystal specifications.
3. Increased tolerance available from pull range less than  $\pm 120$  ppm.



## DC Parameters

Parameter <sup>[4]</sup>	Description	Conditions	Min	Typ	Max	Unit
$I_{OH}^{[5]}$	Output high current	$V_{OH} = V_{DD} - 0.5$ , $V_{DD} = 3.3$ V	12	–	–	mA
$I_{OL}^{[5]}$	Output low current	$V_{OL} = 0.5$ , $V_{DD} = 3.3$ V	12	–	–	mA
$I_{IH}$	Input high current	$V_{IH} = V_{DD}$ , excluding Vin, Xin	–	5	10	$\mu$ A
$I_{IL}$	Input low current	$V_{IL} = 0$ V, excluding Vin, Xin	–	5	10	$\mu$ A
$V_{IH}$	Input high voltage	FS0/1/2 OE input CMOS levels	$0.7 \times A_{VDD}$	–	–	V
$V_{IL}$	Input low voltage	FS0/1/2 OE input CMOS levels	–	–	$0.3 \times A_{VDD}$	V
$V_{VCXO}$	VIN input range	Internal setting in VCXO are XOB/A = 110, Offset = 1110, Gain = 101	0	–	$A_{VDD}$	V
$C_{IN}$	Input capacitance	FS0/1/2 and OE pins only	–	–	7	pF
$I_{VDD}$	Supply current	$V_{DD}/A_{VDD}/V_{DDL}$ current	–	60	–	mA
$C_{INXIN}$	Input capacitance at XIN	VCXO disabled external reference	–	15	–	pF
$C_{INXTAL}$	Input capacitance at crystal	VCXO disabled fixed frequency oscillator	–	12	–	pF

### Notes

- Parameters are guaranteed by design and characterization. Not 100% tested in production. All parameters specified with fully loaded outputs.
- Custom drive level is available upon request.

## AC Parameters

Parameter <sup>[4]</sup>	Description	Conditions	Min	Typ	Max	Units
1/t1	Output frequency	PLL <sub>minmax</sub> /Divider <sub>maximum</sub>	4.2	–	166	MHz
DC1	Output duty cycle (excluding REFOUT)	Duty cycle is defined in Figure 7; t <sub>2</sub> /t <sub>1</sub> , 50% of V <sub>DD</sub> External reference duty cycle between 40% and 60% measured at V <sub>DD</sub> /2 (Clock output is ≤ 125 MHz)	45	50	55	%
DC2	Output duty cycle	Duty cycle is defined in Figure 7; t <sub>2</sub> /t <sub>1</sub> , 50% of V <sub>DD</sub> External reference duty cycle between 40% and 60% measured at V <sub>DD</sub> /2 (Clock output is > 125 MHz)	40	50	60	%
DC <sub>REFOUT</sub>	Output duty cycle	Duty cycle is defined in Figure 7; t <sub>2</sub> /t <sub>1</sub> , 50% of V <sub>DD</sub> (XIN Duty Cycle = 45/55%)	40	50	60	%
ER	Rising edge rate	Output clock edge rate. Measured from 20% to 80% of V <sub>DD</sub> . C <sub>LOAD</sub> = 15 pF. See Figure 8.	0.75	1.2	–	V/ns
EF	Falling edge rate	Output clock edge rate. Measured from 80% to 20% of V <sub>DD</sub> . C <sub>LOAD</sub> = 15 pF. See Figure 8.	0.75	1.2	–	V/ns
T <sub>9</sub>	Clock jitter	Period jitter	–	±250	–	ps
T <sub>10</sub>	PLL lock time		–	1	5	ms
f <sub>ΔXO</sub>	VCXO crystal pull range	Using non-SMD-49 crystal Nominal crystal frequency input assumed (0 ppm) at 25 °C and 3.3 V	±110	±120	–	ppm
		Using SMD-49 crystal Nominal crystal frequency input assumed (0 ppm) at 25 °C and 3.3 V	±105	±120	–	ppm

## Test and Measurement

Figure 6. Test and Measurement

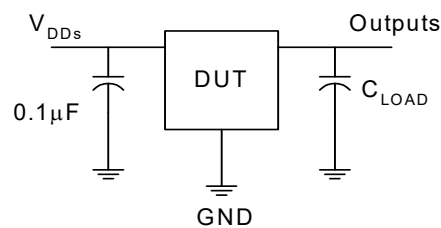



## Voltage and Timing Definitions

Figure 7. Duty Cycle Definition

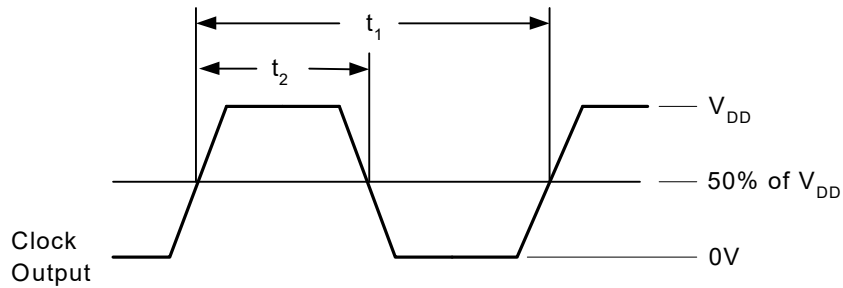

Figure 8.  $ER = (0.6 \times V_{DD})/t_3$ ,  $EF = (0.6 \times V_{DD})/t_4$

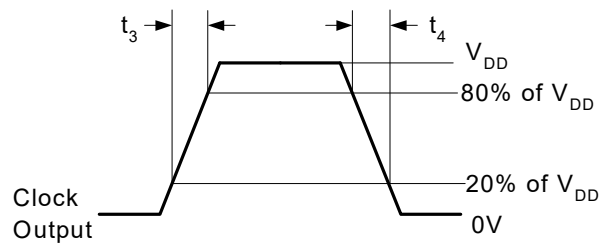
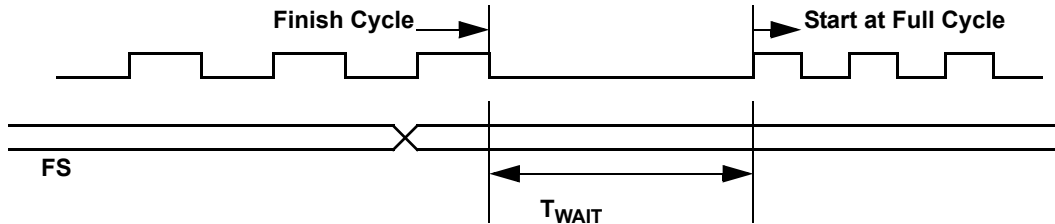

Figure 9. FS Controlled Clock Output





## Ordering Information

All product offerings are factory-programmed customer-specific devices with customized part numbers. The [Possible Configurations](#) table shows the available device types, but not complete part numbers. Contact your local Cypress FAE or sales representative for more information.

Part Number	Package	Type	Production Flow
<b>Pb-free</b>			
CY22388FZXC	ZZ16	16-pin TSSOP	Commercial, 0 °C to +70 °C
CY22388FZXCT	ZZ16	16-pin TSSOP – Tape and Reel	Commercial, 0 °C to +70 °C

## Possible Configurations

Part Number <sup>[6]</sup>	Package	Type	Production Flow
<b>Pb-free</b>			
CY22388ZXC-xxx	ZZ16	16-pin TSSOP	Commercial, 0 °C to +70 °C
CY22388ZXC-xxxT	ZZ16	16-pin TSSOP – Tape and Reel	Commercial, 0 °C to +70 °C
CY22389ZXC-xxx	ZZ20	20-pin TSSOP	Commercial, 0 °C to +70 °C
CY22389ZXC-xxxT	ZZ20	20-pin TSSOP – Tape and Reel	Commercial, 0 °C to +70 °C
CY22391LTXC-xxx	LT32	32-pin QFN (Sawn)	Commercial, 0 °C to +70 °C
CY22391LTXC-xxxT	LT32	32-pin QFN (Sawn) – Tape and Reel	Commercial, 0 °C to +70 °C

## Ordering Code Definitions

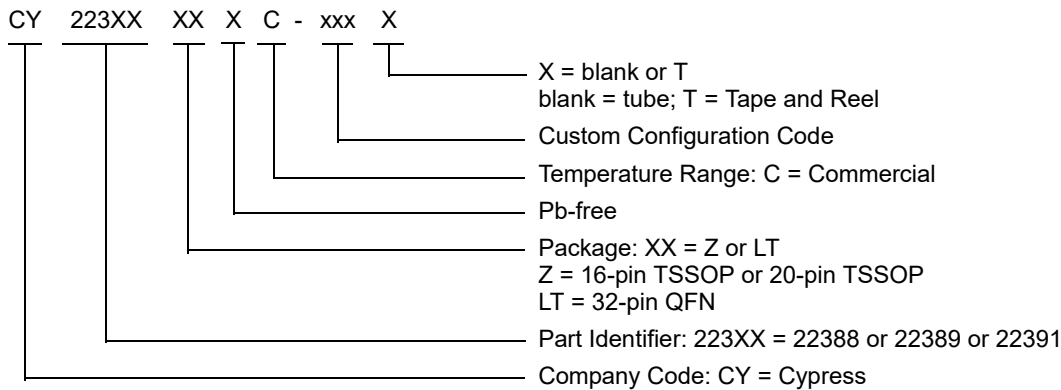

**Note**

6. The CY22388ZXC-xxx, CY22389ZXC-xxx, and CY22391LTXC-xxx are factory-programmed configurations. For more details, contact your local Cypress FAE or sales representative.

## Package Drawing and Dimensions

Figure 10. 16-pin TSSOP (4.40 mm Body) Package Outline, 51-85091

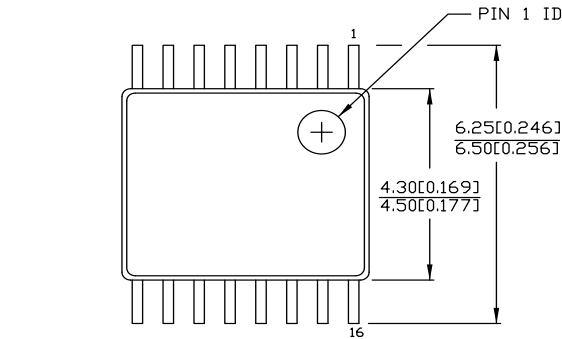

DIMENSIONS IN MM[INCHES] MIN. MAX.

REFERENCE JEDEC MO-153

PACKAGE WEIGHT 0.05gms

PART #	
Z16.173	STANDARD PKG.
ZZ16.173	LEAD FREE PKG.

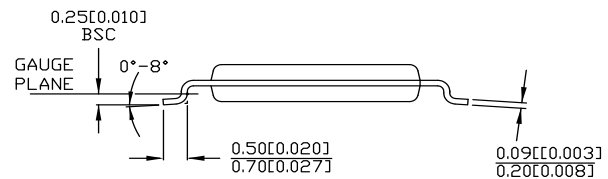
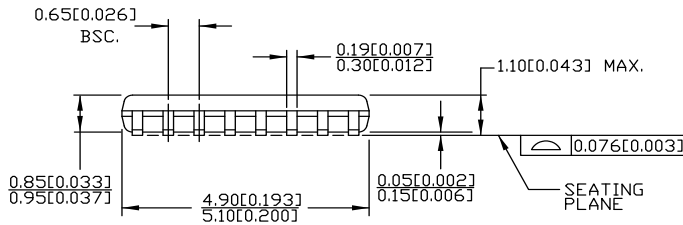

51-85091 \*E

Figure 11. 20-pin TSSOP (4.40 mm Body) Package Outline, 51-85118

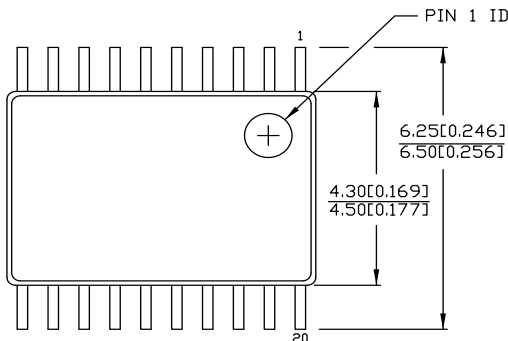

DIMENSIONS IN MM[INCHES] MIN. MAX.

REFERENCE JEDEC MO-153

PART #	
Z20.173	STANDARD PKG.
ZZ20.173	LEAD FREE PKG.

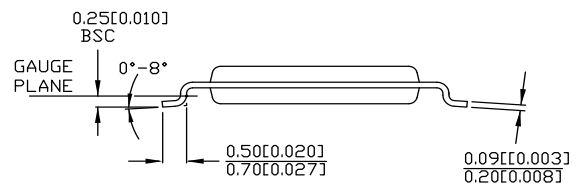
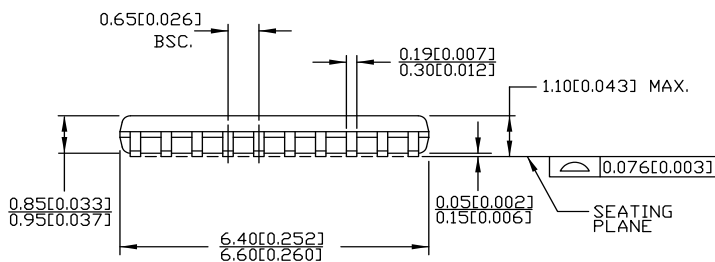

51-85118 \*E





## Acronyms

Acronym	Description
ESD	Electrostatic Discharge
ESR	Equivalent Series Resistance
FAE	Field Application Engineer
FS	Frequency Select
PJ	Period Jitter
PLL	Phase-Locked Loop
QFN	Quad Flat No-leads
TSSOP	Thin Shrunk Small Outline Package
VCO	Voltage-Controlled Oscillator
VCXO	Voltage-Controlled Crystal Oscillator

## Document Conventions

### Units of Measure

Symbol	Unit of Measure
°C	degree Celsius
fF	femtofarad
KΩ	kilohm
MHz	megahertz
μA	microampere
μF	microfarad
μs	microsecond
μW	microwatt
mA	milliampere
ms	millisecond
mV	millivolt
ns	nanosecond
Ω	ohm
PPM	parts per million
pF	picofarad
ps	picosecond
V	volt
W	watt

## Document History Page

Document Title: CY22388/CY22389/CY22391, Factory Programmable, Quad PLL Clock Generator with VCXO Document Number: 38-07734				
Revision	ECN	Orig. of Change	Submission Date	Description of Change
**	320458	RGL	03/07/2005	New data sheet.
*A	389649	RGL	08/02/2005	Updated <a href="#">Pullable Crystal Specifications</a> : Removed typical value of R1 parameter. Changed maximum value of R1 parameter from 50 $\Omega$ to 40 $\Omega$ . Updated details in "Comments" column corresponding to DL parameter. Changed maximum value of DL parameter from 900 $\mu$ W to 300 $\mu$ W. Updated <a href="#">AC Parameters</a> : Changed minimum value of $f_{\Delta XO}$ parameter from $\pm 120$ ppm to $\pm 110$ ppm. Changed typical value of $f_{\Delta XO}$ parameter from blank to $\pm 120$ ppm.
*B	523597	RGL	11/12/2006	Updated <a href="#">AC Parameters</a> : Updated details in "Conditions" column corresponding to $f_{\Delta XO}$ parameter. Retained existing values for $f_{\Delta XO}$ parameter corresponding to Test Condition "Using non-SMD-49 crystal specified in "CY22388 Application Note, ANC0002". Added values for $f_{\Delta XO}$ parameter corresponding to Test Condition "Using SMD-49 crystal specified in "CY22388 Application Note, ANC0002". Updated to new template.
*C	2632357	KVM	01/13/2009	Updated Document Title to read as "CY22388, CY22389, CY22391 Factory Programmable Quad PLL Clock Generator with VCXO". Updated <a href="#">Logic Block Diagram</a> (Clarified that Power Down (PD#) is active-low). Updated <a href="#">Pinouts</a> : Updated <a href="#">Figure 2</a> (Replaced PD with PD#). Updated <a href="#">Pin Definitions</a> : Replaced PD with PD# Updated details in "Description" column corresponding to OE/PD# pin. Updated <a href="#">DC Parameters</a> : Updated details in "Conditions" column corresponding to $V_{VCXO}$ parameter. Updated <a href="#">Ordering Information</a> : Updated part numbers. Added a column "Package" and added details in that column. Added a Note "Not recommended for new designs. The LY32 QFN package transitions to the LT32 QFN." and referred the note in CY22391LFXC-xxx and CY22391LFXC-xxxT. Updated <a href="#">Package Drawing and Dimensions</a> : spec 51-85188 – Changed revision from *A to *B. Updated to new template.
*D	2897246	KVM	03/22/2010	Updated <a href="#">Ordering Information</a> : Added description (Regarding Possible Configurations). Updated <a href="#">Possible Configurations</a> : Updated part numbers. Updated Note 6. Removed Note "Not recommended for new designs. The LY32 QFN package transitions to the LT32 QFN." Updated <a href="#">Package Drawing and Dimensions</a> : 51-85091 – Changed revision from *A to *B. 51-85118 – Changed revision from *A to *B. 001-30999 – Changed revision from *A to *C. Removed spec 51-85188 *B.



Document History Page (continued)

Document Title: CY22388/CY22389/CY22391, Factory Programmable, Quad PLL Clock Generator with VCXO Document Number: 38-07734				
Revision	ECN	Orig. of Change	Submission Date	Description of Change
*E	3030336	CXQ	09/14/2010	Fixed various typos across the document. Updated <a href="#">Features</a> : Fixed formatting. Updated <a href="#">Absolute Maximum Conditions</a> : Updated value of MSL parameter as 3 for all packages. Updated <a href="#">Operating Conditions</a> : Removed "Recommended" from heading. Updated <a href="#">Ordering Information</a> : No change in part numbers. Added <a href="#">Ordering Code Definitions</a> . Updated <a href="#">Package Drawing and Dimensions</a> : spec 51-85091 – Changed revision from *B to *C. spec 51-85118 – Changed revision from *B to *C. Added <a href="#">Acronyms</a> and <a href="#">Units of Measure</a> . Updated to new template.
*F	3786734	PURU	10/29/2012	Updated <a href="#">Pinouts</a> : Updated <a href="#">Figure 3</a> (Updated caption only). Updated <a href="#">Ordering Information</a> : Updated part numbers (Added two part numbers (CY22388FZXC and CY22388FZXCT)). Updated <a href="#">Package Drawing and Dimensions</a> : spec 51-85091 – Changed revision from *C to *D. spec 51-85118 – Changed revision from *C to *D. spec 001-30999 – Changed revision from *C to *D.
*G	4142797	CINM	10/01/2013	Updated to new template. Completing Sunset Review.
*H	4576237	CINM	11/21/2014	Updated <a href="#">Features</a> : Updated output frequency range as 1 MHz to 166 MHz. Updated <a href="#">Functional Description</a> : Added "For a complete list of related documentation, click <a href="#">here</a> ." at the end. Updated <a href="#">Package Drawing and Dimensions</a> : spec 51-85091 – Changed revision from *D to *E. spec 51-85118 – Changed revision from *D to *E.
*I	5475432	XHT	10/14/2016	Updated to new template. Completing Sunset Review.
*J	5995535	AESATMP8	12/15/2017	Updated Cypress Logo and Copyright.
*K	6520812	XHT	03/25/2019	Updated <a href="#">Analog VCXO</a> : Updated description. Updated <a href="#">Pullable Crystal Specifications</a> : Updated Note 2. Updated <a href="#">AC Parameters</a> : Updated details in "Conditions" column corresponding to $f_{\Delta XO}$ parameter. Updated to new template.



## Sales, Solutions, and Legal Information

### Worldwide Sales and Design Support

Cypress maintains a worldwide network of offices, solution centers, manufacturer’s representatives, and distributors. To find the office closest to you, visit us at [Cypress Locations](#).

#### Products

Arm® Cortex® Microcontrollers	<a href="http://cypress.com/arm">cypress.com/arm</a>
Automotive	<a href="http://cypress.com/automotive">cypress.com/automotive</a>
Clocks & Buffers	<a href="http://cypress.com/clocks">cypress.com/clocks</a>
Interface	<a href="http://cypress.com/interface">cypress.com/interface</a>
Internet of Things	<a href="http://cypress.com/iot">cypress.com/iot</a>
Memory	<a href="http://cypress.com/memory">cypress.com/memory</a>
Microcontrollers	<a href="http://cypress.com/mcu">cypress.com/mcu</a>
PSoC	<a href="http://cypress.com/psoc">cypress.com/psoc</a>
Power Management ICs	<a href="http://cypress.com/pmic">cypress.com/pmic</a>
Touch Sensing	<a href="http://cypress.com/touch">cypress.com/touch</a>
USB Controllers	<a href="http://cypress.com/usb">cypress.com/usb</a>
Wireless Connectivity	<a href="http://cypress.com/wireless">cypress.com/wireless</a>

#### PSoC® Solutions

[PSoC 1](#) | [PSoC 3](#) | [PSoC 4](#) | [PSoC 5LP](#) | [PSoC 6 MCU](#)

#### Cypress Developer Community

[Community](#) | [Projects](#) | [Video](#) | [Blogs](#) | [Training](#) | [Components](#)

#### Technical Support

[cypress.com/support](http://cypress.com/support)



© Cypress Semiconductor Corporation, 2005–2019. This document is the property of Cypress Semiconductor Corporation and its subsidiaries (“Cypress”). This document, including any software or firmware included or referenced in this document (“Software”), is owned by Cypress under the intellectual property laws and treaties of the United States and other countries worldwide. Cypress reserves all rights under such laws and treaties and does not, except as specifically stated in this paragraph, grant any license under its patents, copyrights, trademarks, or other intellectual property rights. If the Software is not accompanied by a license agreement and you do not otherwise have a written agreement with Cypress governing the use of the Software, then Cypress hereby grants you a personal, non-exclusive, nontransferable license (without the right to sublicense) (1) under its copyright rights in the Software (a) for Software provided in source code form, to modify and reproduce the Software solely for use with Cypress hardware products, only internally within your organization, and (b) to distribute the Software in binary code form externally to end users (either directly or indirectly through resellers and distributors), solely for use on Cypress hardware product units, and (2) under those claims of Cypress’s patents that are infringed by the Software (as provided by Cypress, unmodified) to make, use, distribute, and import the Software solely for use with Cypress hardware products. Any other use, reproduction, modification, translation, or compilation of the Software is prohibited.

TO THE EXTENT PERMITTED BY APPLICABLE LAW, CYPRESS MAKES NO WARRANTY OF ANY KIND, EXPRESS OR IMPLIED, WITH REGARD TO THIS DOCUMENT OR ANY SOFTWARE OR ACCOMPANYING HARDWARE, INCLUDING, BUT NOT LIMITED TO, THE IMPLIED WARRANTIES OF MERCHANTABILITY AND FITNESS FOR A PARTICULAR PURPOSE. No computing device can be absolutely secure. Therefore, despite security measures implemented in Cypress hardware or software products, Cypress shall have no liability arising out of any security breach, such as unauthorized access to or use of a Cypress product. CYPRESS DOES NOT REPRESENT, WARRANT, OR GUARANTEE THAT CYPRESS PRODUCTS, OR SYSTEMS CREATED USING CYPRESS PRODUCTS, WILL BE FREE FROM CORRUPTION, ATTACK, VIRUSES, INTERFERENCE, HACKING, DATA LOSS OR THEFT, OR OTHER SECURITY INTRUSION (collectively, “Security Breach”). Cypress disclaims any liability relating to any Security Breach, and you shall and hereby do release Cypress from any claim, damage, or other liability arising from any Security Breach. In addition, the products described in these materials may contain design defects or errors known as errata which may cause the product to deviate from published specifications. To the extent permitted by applicable law, Cypress reserves the right to make changes to this document without further notice. Cypress does not assume any liability arising out of the application or use of any product or circuit described in this document. Any information provided in this document, including any sample design information or programming code, is provided only for reference purposes. It is the responsibility of the user of this document to properly design, program, and test the functionality and safety of any application made of this information and any resulting product. “High-Risk Device” means any device or system whose failure could cause personal injury, death, or property damage. Examples of High-Risk Devices are weapons, nuclear installations, surgical implants, and other medical devices. “Critical Component” means any component of a High-Risk Device whose failure to perform can be reasonably expected to cause, directly or indirectly, the failure of the High-Risk Device, or to affect its safety or effectiveness. Cypress is not liable, in whole or in part, and you shall and hereby do release Cypress from any claim, damage, or other liability arising from any use of a Cypress product as a Critical Component in a High-Risk Device. You shall indemnify and hold Cypress, its directors, officers, employees, agents, affiliates, distributors, and assigns harmless from and against all claims, costs, damages, and expenses, arising out of any claim, including claims for product liability, personal injury or death, or property damage arising from any use of a Cypress product as a Critical Component in a High-Risk Device. Cypress products are not intended or authorized for use as a Critical Component in any High-Risk Device except to the limited extent that (i) Cypress’s published data sheet for the product explicitly states Cypress has qualified the product for use in a specific High-Risk Device, or (ii) Cypress has given you advance written authorization to use the product as a Critical Component in the specific High-Risk Device and you have signed a separate indemnification agreement.

Cypress, the Cypress logo, Spansion, the Spansion logo, and combinations thereof, WICED, PSoC, CapSense, EZ-USB, F-RAM, and Traveo are trademarks or registered trademarks of Cypress in the United States and other countries. For a more complete list of Cypress trademarks, visit [cypress.com](http://cypress.com). Other names and brands may be claimed as property of their respective owners.

## Looking for pricing, stock, or lifecycle information?

Click below to explore more details on WIN SOURCE:

-  [View CY22391LFXC-02T on WIN SOURCE](#)
-  [Cypress Semiconductor Corp Information](#)

## Optimize Your Supply Chain with WIN SOURCE Solutions

-  Global Sourcing Solution
-  Obsolete Management
-  Cost Control Management
-  Shortage Management
-  Alternative Solution
-  Excess Inventory Management