



**THE DATASHEET OF  
CY7C68001-56PVXCT**



# EZ-USB SX2™ High-Speed USB Interface Device

## Features

- USB 2.0-certified compliant
  - Test ID number 40000713 on USB-Implementor's Form (USB-IF) integrators list
- Operates at high (480 Mbps) or full (12 Mbps) speed
- Supports control endpoint 0:
  - Used to handle USB device requests
- Supports four configurable endpoints that share a 4-KB FIFO space
  - Endpoints 2, 4, 6, 8 for application-specific control and data
- Standard 8- or 16-bit external master interface
  - Glueless interface to most standard microprocessors DSPs, ASICs, and FPGAs
  - Synchronous or asynchronous interface
- Integrated phase-locked loop (PLL)
- 3.3 V operation, 5 V tolerant I/Os
- 56-pin SSOP and QFN package
- Complies with most device class specifications

## Applications

- DSL modems
- ATA interface
- Memory card readers
- Legacy conversion devices
- Cameras
- Scanners
- Home PNA
- Wireless local area network (LAN)
- MP3 players
- Networking
- Printers

The [Reference Designs](#) section in the Cypress website provides additional tools for typical USB applications. Each reference design comes with firmware source code and object code, schematics, and documentation.

## Logic Block Diagram

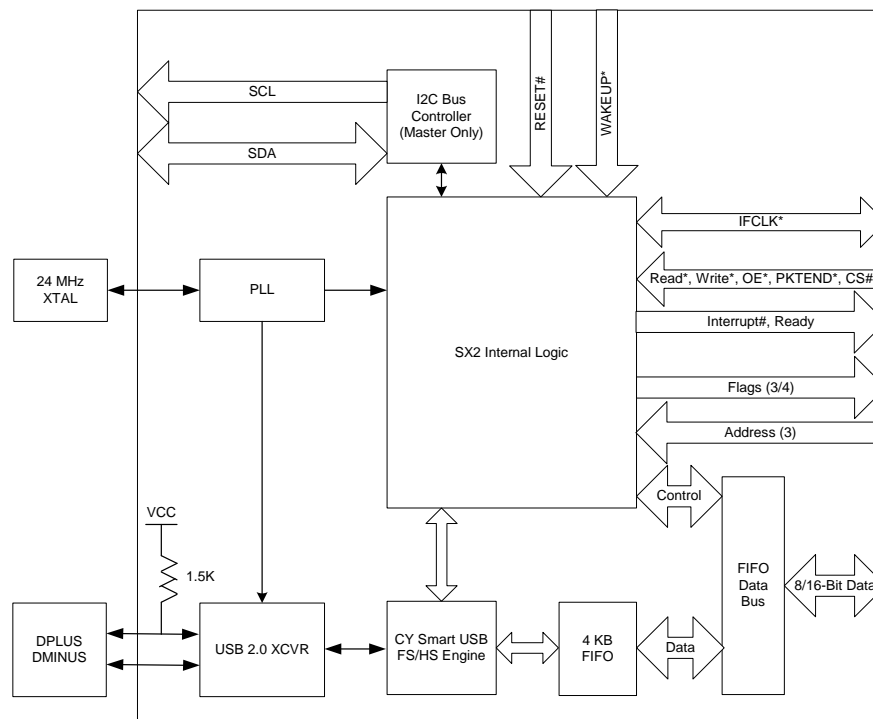

**Errata:** For information on silicon errata, see "Errata" on page 44. Details include trigger conditions, devices affected, and proposed workaround.

## Contents

<b>Functional Description</b> .....	<b>3</b>	<b>Absolute Maximum Ratings</b> .....	<b>24</b>
<b>Functional Overview</b> .....	<b>3</b>	<b>Operating Conditions</b> .....	<b>24</b>
USB Signaling Speed .....	3	<b>DC Electrical Characteristics</b> .....	<b>24</b>
Buses .....	3	<b>AC Electrical Characteristics</b> .....	<b>24</b>
Boot Methods .....	3	USB Transceiver .....	24
Interrupt System .....	4	Command Interface .....	25
Resets and Wakeup .....	5	FIFO Interface .....	27
Endpoint RAM .....	5	Slave FIFO Address to Flags/Data .....	32
External Interface .....	6	Slave FIFO Output Enable .....	33
<b>Enumeration</b> .....	<b>8</b>	Sequence Diagram .....	33
Standard Enumeration .....	8	<b>Default Descriptor [35]</b> .....	<b>37</b>
Default Enumeration .....	9	<b>General PCB Layout Guidelines[36]</b> .....	<b>40</b>
<b>Endpoint 0 [8]</b> .....	<b>9</b>	<b>Quad Flat Package No Leads (QFN) Package</b>	
Resetting Data Toggle .....	10	<b>Design Notes</b> .....	<b>40</b>
<b>Pin Configurations</b> .....	<b>11</b>	<b>Ordering Information</b> .....	<b>41</b>
CY7C68001 Pin Definitions .....	13	Ordering Code Definition .....	41
<b>Register Summary</b> .....	<b>15</b>	<b>Package Diagrams</b> .....	<b>41</b>
IFCONFIG Register 0x01 .....	17	<b>Acronyms</b> .....	<b>43</b>
FLAGSAB/FLAGSCD Registers 0x02/0x03 .....	17	<b>Document Conventions</b> .....	<b>43</b>
POLAR Register 0x04 .....	18	Units of Measure .....	43
REVID Register 0x05 .....	19	<b>Errata</b> .....	<b>44</b>
EPxCFG Register 0x06–0x09 .....	19	Part Numbers Affected .....	44
EPxPKTLENH/L Registers 0x0A–0x11 [17] .....	19	EZ-USB SX2 Qualification Status .....	44
EPxPFH/L Registers 0x12–0x19 .....	20	EZ-USB SX2 Errata Summary .....	44
EPxISOINPKTS Registers 0x1A–0x1D .....	21	<b>Document History Page</b> .....	<b>47</b>
EPxxFLAGS Registers 0x1E–0x1F .....	21	<b>Sales, Solutions, and Legal Information</b> .....	<b>50</b>
INPKTEND/FLUSH Register 0x20 .....	22	Worldwide Sales and Design Support .....	50
USBFRAMEH/L Registers 0x2A, 0x2B .....	22	Products .....	50
MICROFRAME Registers 0x2C .....	22	PSoC@Solutions .....	50
FNADDR Register 0x2D .....	22	Cypress Developer Community .....	50
INTENABLE Register 0x2E .....	22	Technical Support .....	50
DESC Register 0x30 .....	23		
EP0BUF Register 0x31 .....	23		
SETUP Register 0x32 .....	23		
EP0BC Register 0x33 .....	23		

## Functional Description

The EZ-USB SX2™ USB interface device is designed to work with any external master, such as standard microprocessors, DSPs, ASICs, and FPGAs to enable USB 2.0 support for any peripheral design. SX2 has a built-in USB transceiver and serial interface engine (SIE), along with a command decoder to send and receive USB data. The controller has four endpoints that share a 4-KB FIFO space for maximum flexibility and throughput, and Control Endpoint 0. SX2 has three address pins and a selectable 8- or 16-bit data bus for command and data input or output.

**Figure 1. Example USB System Diagram**

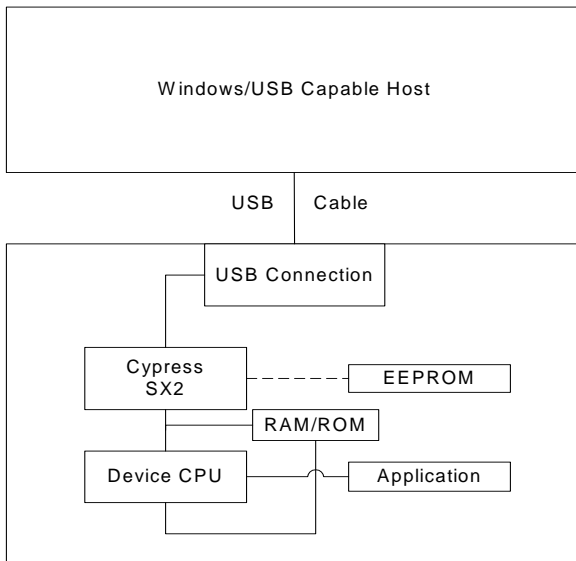

## Functional Overview

### USB Signaling Speed

SX2 operates at two of the three rates defined in the *Universal Serial Bus Specification Revision 2.0*, dated April 27, 2000:

- Full speed, with a signaling bit rate of 12 Mb/s
  - High speed, with a signaling bit rate of 480 Mb/s
- SX2 does not support the low speed signaling rate of 1.5 Mb/s.

### Buses

SX2 features:

- A selectable 8- or 16-bit bidirectional data bus
- An address bus to select the FIFO or command interface

### Notes

1. Because there is no direct way to detect which EEPROM type (single or double address) is connected, SX2 uses the EEPROM address pins A2, A1, and A0 to determine whether to send out one or two bytes of address. Single-byte address EEPROMs such as 24LC01, should be strapped to address 000 and double-byte EEPROMs (24LC64, etc.) should be strapped to address 001.
2. The SCL and SDA pins must be pulled up for this detection method to work properly, even if an EEPROM is not connected. Typical pull up values are 2.2 K $\Omega$ –10 K $\Omega$ .

## Boot Methods

During the power up sequence, internal logic of the SX2 checks for the presence of an I<sup>2</sup>C EEPROM<sup>[1, 2]</sup>. If it finds an EEPROM, it boots off the EEPROM. When the presence of an EEPROM is detected, the SX2 checks the value of first byte. If the first byte is a 0xC4, the SX2 loads the next two bytes into the IFCONFIG and POLAR registers, respectively. If the fourth byte is also 0xC4, the SX2 enumerates using the descriptor in the EEPROM. It then signals to the external master when enumeration is complete through an ENUMOK interrupt, see [Interrupt System](#) on page 4. If no EEPROM is detected, the SX2 relies on the external master for the descriptors. After this descriptor information is received from the external master, the SX2 connects to the USB and enumerates.

### EEPROM Organization

The valid sequence of bytes in the EEPROM is displayed in the following table.

**Table 1. Descriptor Length Set to 0x06: Default Enumeration**

Byte Index	Description
0	0xC4
1	IFCONFIG
2	POLAR
3	0xC4
4	Descriptor Length (LSB): 0x06
5	Descriptor Length (MSB): 0x00
6	VID (LSB)
7	VID (MSB)
8	PID (LSB)
9	PID (MSB)
10	DID (LSB)
11	DID (MSB)

**Table 2. Descriptor Length Not Set to 0x06**

Byte Index	Description
0	0xC4
1	IFCONFIG
2	POLAR
3	0xC4
4	Descriptor Length (LSB)
5	Descriptor Length (MSB)
6	Descriptor[0]
7	Descriptor[1]
8	Descriptor[2]

- **IFCONFIG:** The IFCONFIG byte contains the settings for the IFCONFIG register. The IFCONFIG register bits are defined in [IFCONFIG Register 0x01](#) on page 17. If the external master requires an interface configuration different from the default, that interface can be specified by this byte.
- **POLAR:** The Polar byte contains the polarity of the FIFO flag pin signals. The POLAR register bits are defined in [POLAR Register 0x04](#) on page 18. If the external master requires signal polarity different from the default, the polarity can be specified by this byte.
- **Descriptor:** The Descriptor byte determines if the SX2 loads the descriptor from the EEPROM. If this byte is equal to 0xC4, the SX2 loads the descriptor starting with the next byte. If this byte does not equal 0xC4, the SX2 waits for descriptor information from the external master.
- **Descriptor Length:** The Descriptor length is within the next two bytes and indicates the length of the descriptor contained within the EEPROM. The length is loaded least significant byte (LSB) first, then most significant byte (MSB).
- **Byte Index 6 Starts Descriptor Information:** The descriptor can be a maximum of 500 bytes.

#### Default Enumeration

An optional default descriptor can be used to simplify enumeration. Only the Vendor ID (VID), Product ID (PID), and Device ID (DID) need to be loaded by the SX2 for it to enumerate with this default setup. This information is either loaded from an EEPROM in the case when the presence of an EEPROM ([Table 1](#)) is detected, or the external master may simply load a VID, PID, and DID when no EEPROM is present. In this default enumeration, the SX2 uses the in-built default descriptor (see [Default Descriptor \[35\]](#) on page 37).

If the descriptor length loaded from the EEPROM is 6, SX2 loads a VID, PID, and DID from the EEPROM and enumerate. The VID, PID, and DID are loaded LSB, then MSB. For example, if the VID, PID, and DID are 0x0547, 0x1002, and 0x0001, respectively, then the bytes should be stored as:

- 0x47, 0x05, 0x02, 0x10, 0x01, 0x00.

If there is no EEPROM, SX2 waits for the external master to provide the descriptor information. To use the default descriptor, the external master must write to the appropriate register (0x30) with descriptor length equal to 6 followed by the VID, PID, and DID. See [Default Enumeration](#) on page 9 for further information on how the external master may load the values.

The default descriptor enumerates the following endpoints:

- Endpoint 2: Bulk out, 512 bytes in high speed mode, 64 bytes in full speed mode
- Endpoint 4: Bulk out, 512 bytes in high speed mode, 64 bytes in full speed mode
- Endpoint 6: Bulk in, 512 bytes in high speed mode, 64 bytes in full speed mode
- Endpoint 8: Bulk in, 512 bytes in high speed mode, 64 bytes in full speed mode.

The entire default descriptor is listed in [Default Descriptor \[35\]](#) on page 37.

## Interrupt System

### Architecture

The SX2 provides an output signal that indicates to the external master that the SX2 has an interrupt condition, or that the data from a register read request is available. The SX2 has six interrupt sources: SETUP, EP0BUF, FLAGS, ENUMOK, BUSACTIVITY, and READY. Each interrupt can be enabled or disabled by setting or clearing the corresponding bit in the INTENABLE register.

When an interrupt occurs, the INT# pin is asserted, and the corresponding bit is set in the Interrupt Status Byte. The external master reads the Interrupt Status Byte by strobing SLRD/SLOE. This presents the Interrupt Status Byte on the lower portion of the data bus (FD[7:0]). Reading the Interrupt Status Byte automatically clears the interrupt. Only one interrupt request occurs at a time; the SX2 buffers multiple pending interrupts.

If the external master has initiated a register read request, the SX2 buffers interrupt until the external master has read the data. This insures that after a read sequence has begun, the next interrupt that is received from the SX2 indicates that the corresponding data is available. Following is a description of this INTENABLE register.

### INTENABLE Register Bit Definition

#### Bit 7: SETUP

If this interrupt is enabled, and the SX2 receives a setup packet from the USB host, the SX2 asserts the INT# pin and sets bit 7 in the Interrupt Status Byte. This interrupt only occurs if the setup request is not one that the SX2 automatically handles. For complete details on how to handle the SETUP interrupt, see [Endpoint 0 \[8\]](#) on page 9.

#### Bit 6: EP0BUF

If this interrupt is enabled, and the endpoint 0 buffer becomes available to the external master for read or write operations, the SX2 asserts the INT# pin and sets bit 6 in the Interrupt Status Byte. This interrupt is used for handling the data phase of a setup request. For complete details on how to handle the EP0BUF interrupt, see [Endpoint 0 \[8\]](#) on page 9.

#### Bit 5: FLAGS

If this interrupt is enabled, and any OUT endpoint FIFO's state changes from empty to not empty and from not empty to empty, the SX2 asserts the INT# pin and sets bit 5 in the Interrupt Status Byte. This is an alternative way to monitor the status of OUT endpoint FIFOs instead of using the FLAGA-FLAGD pins, and can be used to indicate when an OUT packet is received from the host.

#### Bit 2: ENUMOK

If this interrupt is enabled and the SX2 receives a SET\_CONFIGURATION request from the USB host, the SX2 asserts the INT# pin and sets bit 2 in the Interrupt Status Byte. This event signals the completion of the SX2 enumeration process.

#### Bit 1: BUSACTIVITY

If this interrupt is enabled, and the SX2 detects either an absence or resumption of activity on the USB bus, the SX2 asserts the INT# pin and sets bit 1 in the Interrupt Status Byte. This usually indicates that the USB host is either suspending or resuming or

that a self-powered device is plugged in or unplugged. If the SX2 is bus-powered, the external master must put the SX2 into a low power mode after detecting a USB suspend condition to be USB-compliant.

#### Bit 0: READY

If this interrupt is enabled, bit 0 in the Interrupt Status Byte is set when the SX2 has powered up and performed a self-test. The external master should always wait for this interrupt before trying to read or write to the SX2, unless an external EEPROM with a valid descriptor is present. If an external EEPROM with a valid descriptor is present, the ENUMOK interrupt occurs instead of the READY interrupt after power up. A READY interrupt also occurs if the SX2 is awakened from a low power mode via the WAKEUP pin. This READY interrupt indicates that the SX2 is ready for commands or data.

#### Qualify with READY Pin on Register Reads

It is true that all interrupts are buffered after a command read request is initiated. However, in rare conditions, there can be a pending interrupt when the external master initiates a read request. In this case, the interrupt status byte is output when the external master asserts the SLRD. So, a condition exists where the Interrupt Status Data Byte can be mistaken for the result of a command register read request. To get around this condition, on getting an interrupt from the interrupt, the external master must first check the status of the READY pin. If the READY is low when the INT# is asserted, the data that is output when the external master strobes the SLRD is the interrupt status byte (not the actual data requested). If the READY pin is high when the interrupt is asserted, the data output on strobing the SLRD is the actual data byte requested by the external master. It is important that the state of the READY pin be checked at the time the INT# is asserted to ascertain the cause of the interrupt.

## Resets and Wakeup

#### Reset<sup>[3]</sup>

An input pin (RESET#) resets the chip. The internal PLL stabilizes after  $V_{CC}$  reaches 3.3 V. Typically, an external RC network ( $R = 100\text{ K}\Omega$ ,  $C = 0.1\ \mu\text{F}$ ) is used to provide the RESET# signal. The clock must be in a stable state for at least 200  $\mu\text{s}$  before the RESET is released.

#### USB Reset

When the SX2 detects a USB reset condition on the USB bus, SX2 handles it similar to any other enumeration sequence. This means that SX2 enumerates again and assert the ENUMOK interrupt to let the external master know that it has enumerated. The external master is then responsible for configuring the SX2 for the application. The external master should also check whether SX2 enumerated at high or full speed to adjust the EPxPKTLENH/L register values accordingly. The last initialization task is for the external master to flush all the SX2 FIFOs.

#### Notes

3. **Errata:** If during the power-on sequence, the SX2 is held in Reset for a long period, it may be recognized by the Host Controller as an Unknown Device and dropped off the USB. For more information, refer "Errata" on page 44.
4. If the descriptor loaded is set for remote wakeup enabled and the host does a set feature remote wakeup enabled, then the SX2 logic performs RESUME signalling after a WAKEUP interrupt.

#### Wakeup

The SX2 exits its low power state when one of the following events occurs:

- USB bus signals a resume. The SX2 asserts a BUSACTIVITY interrupt
- The external master asserts the WAKEUP pin. The SX2 asserts a READY interrupt<sup>[4]</sup>

## Endpoint RAM

#### Size

- Control endpoint: 64 bytes: 1 × 64 bytes (Endpoint 0)
- FIFO Endpoints: 4096 bytes: 8 × 512 bytes (Endpoint 2, 4, 6, 8)

#### Organization

- EP0–Bidirectional Endpoint 0, 64-byte buffer
- EP2, 4, 6, 8–Eight 512-byte buffers, bulk, interrupt, or isochronous. EP2 and EP6 can be either double-, triple-, or quad-buffered. EP4 and EP8 can only be double-buffered. For high speed endpoint configuration options, see [Figure 3](#) on page 11

Endpoint 0 is the same for every configuration as it serves as the CONTROL endpoint. For endpoints 2, 4, 6, and 8, see [Figure 3](#) on page 11. Endpoints 2, 4, 6, and 8 may be configured by choosing either:

- One configuration from Group A and one from Group B
- One configuration from Group C

Some example endpoint configurations are as follows.

- EP2: 1024 bytes double-buffered, EP6: 512 bytes quad-buffered
- EP2: 512 bytes double-buffered, EP4: 512 bytes double-buffered, EP6: 512 bytes double-buffered, EP8: 512 bytes double buffered
- EP2: 1024 bytes quad-buffered

#### Default Endpoint Memory Configuration

At power-on-reset, the endpoint memories are configured as follows:

- EP2: Bulk OUT, 512 bytes/packet, 2x buffered
- EP4: Bulk OUT, 512 bytes/packet, 2x buffered
- EP6: Bulk IN, 512 bytes/packet, 2x buffered
- EP8: Bulk IN, 512 bytes/packet, 2x buffered

Figure 2. Endpoint Configurations (High Speed Mode)

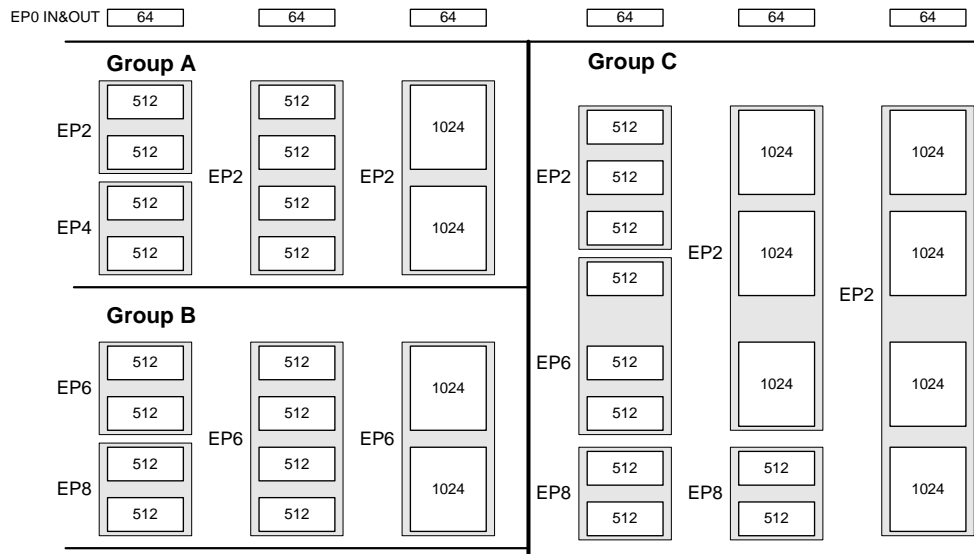

**External Interface**

The SX2 presents two interfaces to the external master.

- A FIFO interface through which EP2, 4, 6, and 8 data flows
- A command interface, which is used to set up the SX2, read status, load descriptors, and access Endpoint 0

*Architecture*

The SX2 slave FIFO architecture has eight 512-byte blocks in the endpoint RAM that directly serve as FIFO memories and are controlled by FIFO control signals (IFCLK, CS#, SLRD, SLWR, SLOE, PKTEND, and FIFOADR[2:0]).

The SX2 command interface is used to set up the SX2, read status, load descriptors, and access endpoint 0. The command interface has its own READY signal for gating writes, and an INT# signal to indicate that the SX2 has data to be read, or that an interrupt event has occurred. The command interface uses the same control signals (IFCLK, CS#, SLRD, SLWR, SLOE, and FIFOADR[2:0]) as the FIFO interface, except for PKTEND.

*Control Signals*

**FIFOADDR Lines**

The SX2 has three address pins that are used to select either the FIFOs or the command interface. The addresses correspond to the following table.

Table 3. FIFO Address Lines Setting

Address/Selection	FIFOADR2	FIFOADR1	FIFOADR0
FIFO2	0	0	0
FIFO4	0	0	1
FIFO6	0	1	0
FIFO8	0	1	1
COMMAND	1	0	0

Table 3. FIFO Address Lines Setting (continued)

Address/Selection	FIFOADR2	FIFOADR1	FIFOADR0
RESERVED	1	0	1
RESERVED	1	1	0
RESERVED	1	1	1

The SX2 accepts either an internally derived clock (30 MHz or 48 MHz) or externally supplied clock (IFCLK, 5 to 50 MHz), and SLRD, SLWR, SLOE, PKTEND, CS#, FIFOADR[2:0] signals from an external master. The interface can be selected for 8- or 16-bit operation by an internal configuration bit, and an Output Enable signal SLOE enables the data bus driver of the selected width. The external master must ensure that the output enable signal is inactive when writing data to the SX2. The interface can operate either asynchronously where the SLRD and SLWR signals act directly as strobes, or synchronously where the SLRD and SLWR act as clock qualifiers. The optional CS# signal tristates the data bus and ignores SLRD, SLWR, PKTEND.

The external master reads from OUT endpoints and writes to IN endpoints, and reads from or writes to the command interface.

**Read: SLOE and SLRD**

In synchronous mode, the FIFO pointer is incremented on each rising edge of IFCLK while SLRD is asserted. In asynchronous mode, the FIFO pointer is incremented on each asserted-to-deasserted transition of SLRD.

SLOE is a data bus driver enable. When SLOE is asserted, the data bus is driven by the SX2.

**Write: SLWR**

In synchronous mode, data on the FD bus is written to the FIFO (and the FIFO pointer is incremented) on each rising edge of IFCLK while SLWR is asserted. In asynchronous mode, data on the FD bus is written to the FIFO (and the FIFO pointer is

incremented) on each asserted-to-deasserted transition of SLWR.

### PKTEND

PKTEND commits the current buffer to USB. To send a short IN packet (one which is not filled to maximum packet size determined by the value of PL[X:0] in EPxPKTLENH/L), the external master strobes the PKTEND pin.

All these interface signals have a default polarity of low. To change the polarity of PKTEND pin, the master may write to the POLAR register anytime. To switch the polarity of the SLWR/SLRD/SLOE, the master must set the appropriate bits 2, 3, and 4 respectively in the FIFOPINPOLAR register located at XDATA space 0xE609. Note that the SX2 powers up with the polarities set to low. [POLAR Register 0x04](#) on page 18 provides further information on how to access this register located at XDATA space.

### IFCLK

The IFCLK pin can be configured to be either an input (default) or an output interface clock. Bits IFCONFIG[7:4] define the behavior of the interface clock. To use the SX2's internally derived 30- or 48 MHz clock, set IFCONFIG.7 to '1' and set IFCONFIG.6 to 0 (30 MHz) or to '1' (48 MHz). To use an externally supplied clock, set IFCONFIG.7 to '0' and drive the IFCLK pin (5 MHz to 50 MHz). The input or output IFCLK signal can be inverted by setting IFCONFIG.4 to '1'.

### FIFO Access

An external master can access the slave FIFOs either asynchronously or synchronously:

- Asynchronous—SLRD, SLWR, and PKTEND pins are strobes.
- Synchronous—SLRD, SLWR, and PKTEND pins are enables for the IFCLK clock pin.

An external master accesses the FIFOs through the data bus, FD [15:0]. This bus can be either 8- or 16-bits wide; the width is selected using the WORDWIDE bit in the EPxPKTLENH/L registers. The data bus is bidirectional, with its output drivers controlled by the SLOE pin. The FIFOADR[2:0] pins select which of the four FIFOs is connected to the FD [15:0] bus, or if the command interface is selected.

### FIFO Flag Pins Configuration

The FIFO flags are FLAGA, FLAGB, FLAGC, and FLAGD. These FLAGx pins report the status of the FIFO selected by the FIFOADR[2:0] pins. At reset, these pins are configured to report the status of the following:

- FLAGA reports the status of the programmable flag
- FLAGB reports the status of the full flag
- FLAGC reports the status of the empty flag
- FLAGD defaults to the CS# function

The FIFO flags can either be indexed or fixed. Fixed flags report the status of a particular FIFO regardless of the value on the FIFOADR [2:0] pins. Indexed flags report the status of the FIFO selected by the FIFOADR [2:0] pins.<sup>[5]</sup>

#### Note

5. In indexed mode, the value of the FLAGx pins is indeterminate except when addressing a FIFO (FIFOADR[2:0]={000,001,010,011}).

### Default FIFO Programmable Flag Setup

By default, FLAGA is the programmable flag (PF) for the endpoint being pointed to by the FIFOADR[2:0] pins. For EP2 and EP4, the default endpoint configuration is BULK, OUT, 512, 2x; the PF pin asserts when the entire FIFO has  $\geq 512$  bytes. For EP6 and EP8, the default endpoint configuration is BULK, IN, 512, 2x, and the PF pin asserts when the entire FIFO has less than/equal to 512 bytes. In other words, EP6/8 report a half-empty state, and EP2/4 report a half-full state.

### FIFO Programmable Flag (PF) Setup

Each FIFO's programmable flag (PF) asserts when the FIFO reaches a user-defined fullness threshold. That threshold is configured as follows:

1. For OUT packets: The threshold is stored in PFC12:0. The PF is asserted when the number of bytes in the entire FIFO is less than/equal to (DECIS = 0) or greater than/equal to (DECIS = 1) the threshold.
2. For IN packets, with PKTSTAT = 1: The threshold is stored in PFC9:0. The PF is asserted when the number of bytes written into the current packet in the FIFO is less than/equal to (DECIS = 0) or greater than/equal to (DECIS = 1) the threshold.
3. For IN packets, with PKTSTAT = 0: The threshold is stored in two parts: PKTS2:0 holds the number of committed packets, and PFC9:0 holds the number of bytes in the current packet. The PF is asserted when the FIFO is at or less full than (DECIS = 0), or at or more full than (DECIS = 1), the threshold.

### Command Protocol

An address of [1 0 0] on FIFOADR [2:0] selects the command interface. The command interface is used to write to and read from the SX2 registers and the Endpoint 0 buffer, as well as the descriptor RAM. Command read and write transactions occur over FD[7:0] only. Each byte written to the SX2 is either an address or a data byte, as determined by bit7. If bit7 = 1, then the byte is considered an address byte. If bit7 = 0, then the byte is considered a data byte. If bit7 = 1, then bit6 determines whether the address byte is a read request or a write request. If bit6 = 1, then the byte is considered a read request. If bit6 = 0 then the byte is considered a write request. Bits [5:0] hold the register address of the request. The format of the command address byte is shown in [Table 4](#).

**Table 4. Command Address Byte**

Address/ Data#	Read/ Write#	A5	A4	A3	A2	A1	A0
Bit 7	Bit 6	Bit 5	Bit 4	Bit 3	Bit 2	Bit 1	Bit 0

Each Write request is followed by two or more data bytes. If another address byte is received before both data bytes are received, the SX2 ignores the first address and any incomplete data transfers. The format for the data bytes is shown in [Table 5](#) and [Table 6](#). Some registers take a series of bytes. Each byte is transferred using the same protocol.

**Table 5. Command Data Byte One**

Bit 7	Bit 6	Bit 5	Bit 4	Bit 3	Bit 2	Bit 1	Bit 0
0	X	X	X	D7	D6	D5	D4

**Table 6. Command Data Byte Two**

Bit 7	Bit 6	Bit 5	Bit 4	Bit 3	Bit 2	Bit 1	Bit 0
0	X	X	X	D3	D2	D1	D0

The first command data byte contains the upper nibble of data, and the second command byte contains the lower nibble of data.

**Write Request Example**

Prior to writing to a register, two conditions must be met: FIFOADR[2:0] must hold [1 0 0], and the Ready line must be HIGH. The external master should not initiate a command if the READY pin is not in a High state.

**Example:** To write the byte <10110000> into the IFCONFIG register (0x01), first send a command address byte as follows.

**Table 7. Command Address Write Byte**

Address/Data#	Read/Write#	A5	A4	A3	A2	A1	A0
1	0	0	0	0	0	0	1

- The first bit signifies an address transfer.
- The second bit signifies that this is a write command.
- The next six bits represent the register address (000001 binary = 0x01 hex).

After the byte is received, the SX2 pulls the READY pin low to inform the external master not to send any more information. When the SX2 is ready to receive the next byte, the SX2 pulls the READY pin high again. This next byte, the upper nibble of the data byte, is written to the SX2 as follows.

**Table 8. Command Data Write Byte One**

Address/Data#	Don't Care	Don't Care	Don't Care	D7	D6	D5	D4
0	X	X	X	1	0	1	1

- The first bit signifies that this is a data transfer.
- The next three are don't care bits.
- The next four bits hold the upper nibble of the transferred byte.

After the byte is received, the SX2 pulls the READY pin low to inform the external master not to send any more information. When the SX2 is ready to receive the next byte, the SX2 pulls the READY pin high again. This next byte, the lower nibble of the data byte is written to the SX2.

**Table 9. Command Data Write Byte Two**

Address/Data#	Don't Care	Don't Care	Don't Care	D3	D2	D1	D0
0	X	X	X	0	0	0	0

**Notes**

6. An important note: When the SX2 receives a Read request, the SX2 allocates the interrupt line solely for the read request. If one of the six interrupt sources described in [Interrupt System](#) on page 4 is asserted, the SX2 buffers that interrupt until the read request completes.
7. These and all other data bytes must conform to the command protocol.

At this point, the entire byte <10110000> is transferred to register 0x01 and the write sequence is complete.

**Read Request Example**

The Read cycle is simpler than the write cycle. The Read cycle consists of a read request from the external master to the SX2. For example, to read the contents of register 0x01, a command address byte is written to the SX2 as follows.

**Table 10. Command Address Read Byte**

Address/Data#	Read/Write#	A5	A4	A3	A2	A1	A0
1	1	0	0	0	0	0	1

When the data is ready to be read, the SX2 asserts the INT# pin to tell the external master that the data it requested is waiting on FD[7:0].<sup>[6]</sup>

**Enumeration**

The SX2 has two modes of enumeration. The first mode is automatic through EEPROM boot load, as described in [Boot Methods](#) on page 3. The second method is a manual load of the descriptor or VID, PID, and DID as described in the following section.

**Standard Enumeration**

The SX2 has 500 bytes of descriptor RAM into which the external master may write its descriptor. The descriptor RAM is accessed through register 0x30. To load a descriptor, the external master does the following:

- Initiate a Write Request to register 0x30.
- Write two bytes (four command data transfers) that define the length of the entire descriptor about to be transferred. The LSB is written first, followed by the MSB.<sup>[7]</sup>
- Write the descriptor, one byte at a time until complete.<sup>[7]</sup>

Note that the register address is only written once.

After the entire descriptor is transferred, the SX2 floats the pull up resistor connected to D+, and parse through the descriptor to locate the individual descriptors. After the SX2 has parsed the entire descriptor, the SX2 connects the pull-up resistor and enumerate automatically. When enumeration is complete, the SX2 notifies the external master with an ENUMOK interrupt.

The format and order of the descriptor should be as follows (see [Default Descriptor \[35\]](#) on page 37 for an example):

- Device
- Device qualifier
- High speed configuration, high speed interface, high speed endpoints
- Full speed configuration, full speed interface, full speed endpoints
- String

The SX2 can be set to run in full speed only mode. To force full speed only enumeration write a 0x02 to the unindexed register CT1 at address 0xE6FB before downloading the descriptors. This disables the chirp mechanism forcing the SX2 to come up in full speed only mode after the descriptors are loaded. The CT1 register can be accessed using the unindexed register mechanism. Examples of writing to unindexed registers are shown in [Resetting Data Toggle](#) on page 10. Each write consists of a command write with the target register followed by the write of the upper nibble of the value followed by the write of the lower nibble of the value.

## Default Enumeration

The external master can load a VID, PID, and DID and use the default descriptor built into the SX2. To use the default descriptor, the descriptor length described in the previous section must equal 6. After the external master has written the length, the VID, PID, and DID must be written LSB, then MSB. For example, if the VID, PID, and DID are 0x04B4, 0x1002, and 0x0001 respectively, then the external master does the following:

- Initiates a Write Request to register 0x30.
- Writes two bytes (four command data transfers) that define the length of the entire descriptor about to be transferred. In this case, the length is always six.
- Writes the VID, PID, and DID bytes: 0xB4, 0x04, 0x02, 0x10, 0x01, 0x00 (in nibble format per the command protocol).

The default descriptor is listed in [Default Descriptor \[35\]](#) on page 37. The default descriptor can be used as a starting point for a custom descriptor.

## Endpoint 0 <sup>[8]</sup>

The SX2 automatically responds to USB chapter 9 requests without any external master intervention. If the SX2 receives a request to which it cannot respond automatically, the SX2 notifies the external master. The external master then has the choice of responding to the request or stalling.

After the SX2 receives a setup packet to which it cannot respond automatically, the SX2 asserts a SETUP interrupt. After the external master reads the Interrupt Status Byte to determine that the interrupt source was the SETUP interrupt, it can initiate a read request to the SETUP register, 0x32. When the SX2 sees a read request for the SETUP register, it presents the first byte of setup data to the external master. Each additional read request presents the next byte of setup data, until all eight bytes are read.

The external master can stall this request at this or any other time. To stall a request, the external master initiates a write request for the SETUP register, 0x32, and writes any non-zero value to the register.

If this setup request has a data phase, the SX2 then interrupts the external master with an EP0BUF interrupt when the buffer becomes available. The SX2 determines the direction of the setup request and interrupts when either:

- IN: the Endpoint 0 buffer becomes available to write to, or

- OUT: the Endpoint 0 buffer receives a packet from the USB host.

For an IN setup transaction, the external master can write up to 64 bytes at a time for the data phase. The steps to write a packet are as follows:

1. Wait for an EP0BUF interrupt, indicating that the buffer is available.
2. Initiate a write request for register 0x31.
3. Write one data byte.
4. Repeat steps 2 and 3 until either all the data or 64 bytes are written, whichever is less.
5. Write the number of bytes in this packet to the byte count register, 0x33.

To send more than 64 bytes, the process is repeated. The SX2 internally stores the length of the data phase that was specified in the wLength field (bytes 6,7) of the setup packet. To send less than the requested amount of data, the external master writes a packet that is less than 64 bytes, or if a multiple of 64, the external master follows the data with a zero-length packet. When the SX2 sees a short or zero-length packet, it completes the setup transfer by automatically completing the handshake phase. The SX2 does not enable more data than the wLength field specified in the setup packet. Note that the PKTEND pin does not apply to Endpoint 0. The only way to send a short or zero length packet is by writing to the byte count register with the appropriate value.

For an OUT setup transaction, the external master can read each packet received from the USB host during the data phase. The steps to read a packet are as follows:

1. Wait for an EP0BUF interrupt, indicating that a packet was received from the USB host into the buffer.
2. Initiate a read request for the byte count register, 0x33. This indicates the amount of data received from the host.
3. Initiate a read request for register 0x31.
4. Read one byte.
5. Repeat steps 3 and 4 until the number of bytes specified in the byte count register are read.

To receive more than 64 bytes, the process is repeated. The SX2 internally stores the length of the data phase that was specified in the wLength field of the setup packet (bytes 6,7). When the SX2 sees that the specified number of bytes have been received, it completes the set up transfer by automatically completing the handshake phase. If the external master does not wish to receive the entire transfer, it can stall the transfer.

If the SX2 receives another setup packet before the current transfer has completed, it interrupts the external master with another SETUP interrupt. If the SX2 receives a setup packet with no data phase, the external master can accept the packet and complete the handshake phase by writing zero to the byte count register.

The SX2 automatically responds to all USB standard requests covered in chapter 9 of the USB 2.0 specification except the Set/Clear Feature Endpoint requests. When the host issues a Set Feature or a Clear feature request, the SX2 triggers a SETUP interrupt to the external master.

### Note

8. **Errata:** SX2 doesn't wait for the external master to write zero into byte count register in the case of non-standard EP0 requests with no data phase. Instead SX2 acknowledges the transfer by itself. For more information, refer "[Errata](#)" on page 44.

The USB spec requires that the device respond to the Set endpoint feature request by doing the following:

- Set the STALL condition on that endpoint.

The USB spec requires that the device respond to the Clear endpoint feature request by doing the following:

- Reset the Data Toggle for that endpoint
- Clear the STALL condition of that endpoint.

The register that is used to reset the data toggle TOGCTL (located at XDATA location 0xE683) is not an index register that can be addressed by the command protocol presented in [Command Protocol](#) on page 7. The following section provides further information on this register bits and how to reset the data toggle accordingly using a different set of command protocol sequence.

### Resetting Data Toggle

**Table 11. Bit definition of the TOGCTL register**

TOGCTL									0xE683
Bit #	7	6	5	4	3	2	1	0	
Bit Name	Q	S	R	I/O	EP3	EP2	EP1	EP0	
Read/Write	R	W	W	R/W	R/W	R/W	R/W	R/W	
Default	0	0	1	1	0	0	1	0	

**Bit 7: Q, Data Toggle Value**

Q=0 indicates DATA0 and Q=1 indicates DATA1, for the endpoint selected by the I/O and EP3:0 bits. Write the endpoint select bits (IO and EP3:0), before reading this value.

**Bit 6: S, Set Data Toggle to DATA1**

After selecting the desired endpoint by writing the endpoint select bits (IO and EP3:0), set S=1 to set the data toggle to DATA1. The endpoint selection bits should not be changed while this bit is written.

**Bit 5: R, Set Data Toggle to DATA0**

Set R=1 to set the data toggle to DATA0. The endpoint selection bits should not be changed while this bit is written.

**Bit 4: IO, Select IN or OUT Endpoint**

Set this bit to select an endpoint direction prior to setting its R or S bit. IO=0 selects an OUT endpoint, IO = 1 selects an IN endpoint.

**Bit 3-0: EP3:0, Select Endpoint**

Set these bits to select an endpoint prior to setting its R or S bit. Valid values are 0, 1, 2, 6, and 8.

A two-step process is employed to clear an endpoint data toggle bit to 0. First, write to the TOGCTL register with an endpoint

address (EP3:EP0) plus a direction bit (IO). Keeping the endpoint and direction bits the same, write a “1” to the R (reset) bit. For example, to clear the data toggle for EP6 configured as an “IN” endpoint, write the following values sequentially to TOGCTL:

00010110b

00110110b

Following is the sequence of events that the master should perform to set this register to 0x16:

- Send Low Byte of the register (0x83)
  - Command **address** write of address 0x3A
  - Command **data** write of upper nibble of the Low Byte of Register Address (0x08)
  - Command **data** write of lower nibble of the Low Byte of Register Address (0x03)
- Send High Byte of the register (0xE6)
  - Command **address** write of address 0x3B
  - Command **data** write of upper nibble of the High Byte of Register Address (0x0E)
  - Command **data** write of lower nibble of the High Byte of Register Address (0x06)
- Send the actual value to write to the register (in this case 0x16)
  - Command **address** write of address 0x3C
  - Command **data** write of upper nibble of the register value (0x01)
  - Command **data** write of lower nibble of the register value (0x06)

The same command sequence needs to be followed to set TOGCTL register to 0x36. The same command protocol sequence can be used to reset the data toggle for the other endpoints.

To read the status of this register, the external master must do the following sequence of events:

- Send Low Byte of the Register (0x83)
  - Command **address** write of 0x3A
  - Command **data** write of upper nibble of the Low Byte of Register Address (0x08)
  - Command **data** write of lower nibble of the Low Byte of Register Address (0x03)
- Send High Byte of the Register (0xE6)
  - Command **address** write of address 0x3B
  - Command **data** write of upper nibble of the High Byte of Register Address (0x0E)
  - Command **data** write of lower nibble of the High Byte of Register Address (0x06)
- Get the actual value from the TOGCTL register (0x16)
  - Command **address READ** of 0x3C

## Pin Configurations

Figure 3. CY7C68001 56-Pin SSOP Pin Assignment <sup>[9]</sup>

1	FD13	FD12	56
2	FD14	FD11	55
3	FD15	FD10	54
4	GND	FD9	53
5	NC	FD8	52
6	VCC	*WAKEUP	51
7	GND	VCC	50
8	*SLRD	RESET#	49
9	*SLWR	GND	48
10	AVCC	*FLAGD/CS#	47
11	XTALOUT	*PKTEND	46
12	XTALIN	FIFOADR1	45
13	AGND	FIFOADR0	44
14	VCC	FIFOADR2	43
15	DPLUS	*SLOE	42
16	DMINUS	INT#	41
17	GND	READY	40
18	VCC	VCC	39
19	GND	*FLAGC	38
20	*IFCLK	*FLAGB	37
21	RESERVED	*FLAGA	36
22	SCL	GND	35
23	SDA	VCC	34
24	VCC	GND	33
25	FD0	FD7	32
26	FD1	FD6	31
27	FD2	FD5	30
28	FD3	FD4	29

**Note**

9. A \* denotes programmable polarity.

Figure 4. CY7C68001 56-pin QFN Assignment [10]

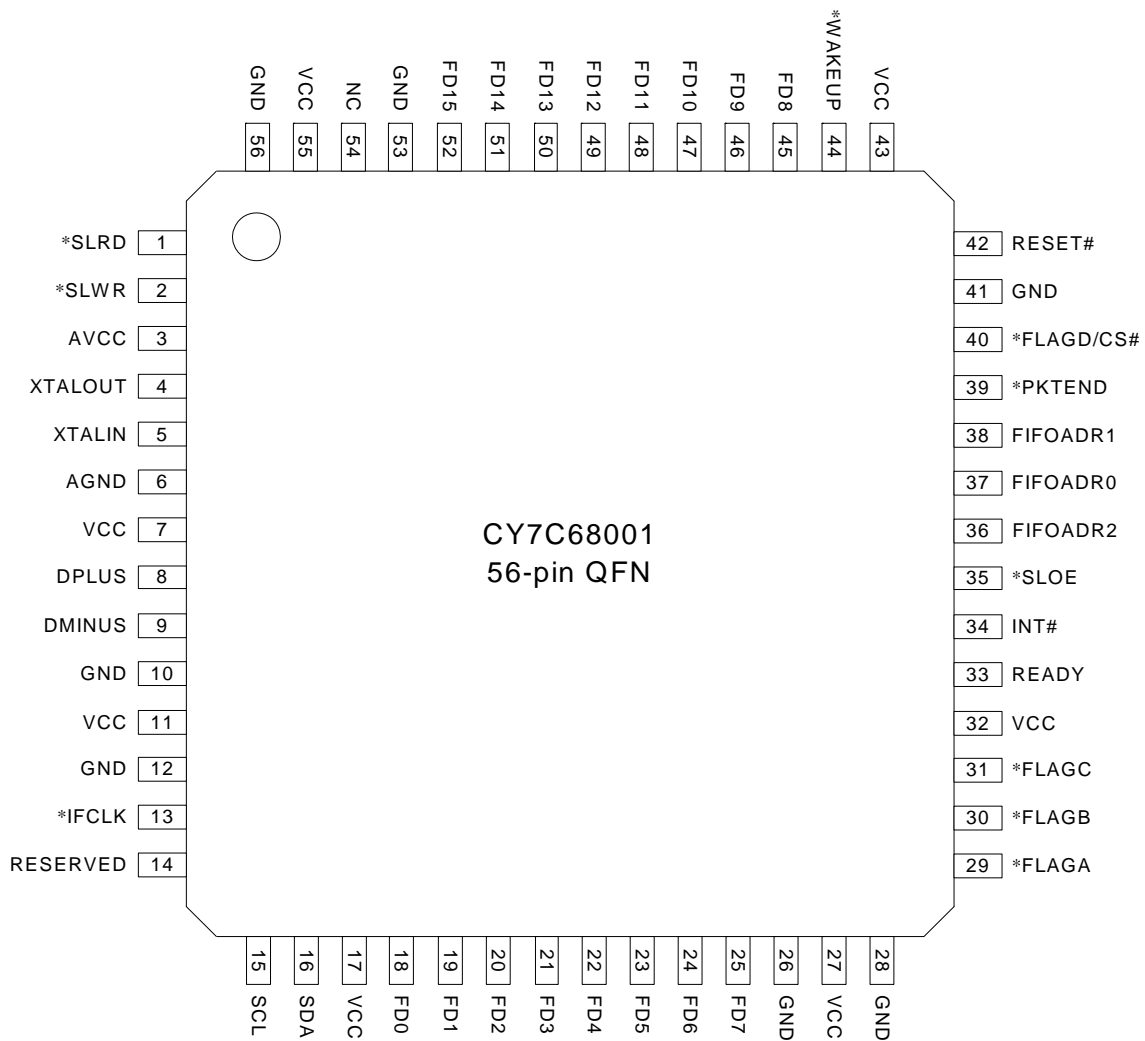

**Note**  
10. A \* denotes programmable polarity.

**CY7C68001 Pin Definitions**
**Table 12. SX2 Pin Definitions**

QFN Pin	SSOP Pin	Name	Type	Default	Description
3	10	AVCC	Power	N/A	<b>Analog V<sub>CC</sub></b> . This signal provides power to the analog section of the chip.
6	13	AGND	Power	N/A	<b>Analog Ground</b> . Connect to ground with as short a path as possible.
9	16	DMINUS	I/O/Z	Z	<b>USB D- Signal</b> . Connect to the USB D- signal.
8	15	DPLUS	I/O/Z	Z	<b>USB D+ Signal</b> . Connect to the USB D+ signal.
42	49	RESET#	Input	N/A	<b>Active LOW Reset</b> . Resets the entire chip. This pin is normally tied to V <sub>CC</sub> through a 100-K resistor, and to GND through a 0.1-μF capacitor.
5	12	XTALIN	Input	N/A	<b>Crystal Input</b> . Connect this signal to a 24 MHz parallel-resonant, fundamental mode crystal and 20 pF capacitor to GND. It is also correct to drive XTALIN with an external 24 MHz square wave derived from another clock source.
4	11	XTALOUT	Output	N/A	<b>Crystal Output</b> . Connect this signal to a 24 MHz parallel-resonant, fundamental mode crystal and 20 pF capacitor to GND. If an external clock is used to drive XTALIN, leave this pin open.
54	5	NC	Output	O	<b>No Connect</b> . This pin must be left unconnected.
33	40	READY	Output	L	<b>READY</b> is an output-only ready that gates external command reads and writes. Active High.
34	41	INT#	Output	H	<b>INT#</b> is an output-only external interrupt signal. Active Low.
35	42	SLOE	Input	I	<b>SLOE</b> is an input-only output enable with programmable polarity (POLAR.4) for the slave FIFOs connected to FD[7:0] or FD[15:0].
36	43	FIFOADR2	Input	I	<b>FIFOADR2</b> is an input-only address select for the slave FIFOs connected to FD[7:0] or FD[15:0].
37	44	FIFOADR0	Input	I	<b>FIFOADR0</b> is an input-only address select for the slave FIFOs connected to FD[7:0] or FD[15:0].
38	45	FIFOADR1	Input	I	<b>FIFOADR1</b> is an input-only address select for the slave FIFOs connected to FD[7:0] or FD[15:0].
39	46	PKTEND	Input	I	<b>PKTEND</b> is an input-only packet end with programmable polarity (POLAR.5) for the slave FIFOs connected to FD[7:0] or FD[15:0].
40	47	FLAGD/C S#	CS#:I FLAGD:O	I	<b>FLAGD</b> is a programmable slave-FIFO output status flag signal. CS# is a master chip select (default).
18	25	FD[0]	I/O/Z	I	<b>FD[0]</b> is the bidirectional FIFO/Command data bus.
19	26	FD[1]	I/O/Z	I	<b>FD[1]</b> is the bidirectional FIFO/Command data bus.
20	27	FD[2]	I/O/Z	I	<b>FD[2]</b> is the bidirectional FIFO/Command data bus.
21	28	FD[3]	I/O/Z	I	<b>FD[3]</b> is the bidirectional FIFO/Command data bus.
22	29	FD[4]	I/O/Z	I	<b>FD[4]</b> is the bidirectional FIFO/Command data bus.
23	30	FD[5]	I/O/Z	I	<b>FD[5]</b> is the bidirectional FIFO/Command data bus.
24	31	FD[6]	I/O/Z	I	<b>FD[6]</b> is the bidirectional FIFO/Command data bus.
25	32	FD[7]	I/O/Z	I	<b>FD[7]</b> is the bidirectional FIFO/Command data bus.
45	52	FD[8]	I/O/Z	I	<b>FD[8]</b> is the bidirectional FIFO data bus.
46	53	FD[9]	I/O/Z	I	<b>FD[9]</b> is the bidirectional FIFO data bus.
47	54	FD[10]	I/O/Z	I	<b>FD[10]</b> is the bidirectional FIFO data bus.
48	55	FD[11]	I/O/Z	I	<b>FD[11]</b> is the bidirectional FIFO data bus.
49	56	FD[12]	I/O/Z	I	<b>FD[12]</b> is the bidirectional FIFO data bus.
50	1	FD[13]	I/O/Z	I	<b>FD[13]</b> is the bidirectional FIFO data bus.
51	2	FD[14]	I/O/Z	I	<b>FD[14]</b> is the bidirectional FIFO data bus.
52	3	FD[15]	I/O/Z	I	<b>FD[15]</b> is the bidirectional FIFO data bus.

**Table 12. SX2 Pin Definitions** (continued)

QFN Pin	SSOP Pin	Name	Type	Default	Description
1	8	SLRD	Input	N/A	<b>SLRD</b> is the input-only read strobe with programmable polarity (POLAR.3) for the slave FIFOs connected to FD[7:0] or FD[15:0].
2	9	SLWR	Input	N/A	<b>SLWR</b> is the input-only write strobe with programmable polarity (POLAR.2) for the slave FIFOs connected to FD[7:0] or FD[15:0].
29	36	FLAGA	Output	H	<b>FLAGA</b> is a programmable slave-FIFO output status flag signal. Defaults to PF for the FIFO selected by the FIFOADR[2:0] pins.
30	37	FLAGB	Output	H	<b>FLAGB</b> is a programmable slave-FIFO output status flag signal. Defaults to FULL for the FIFO selected by the FIFOADR[2:0] pins.
31	38	FLAGC	Output	H	<b>FLAGC</b> is a programmable slave-FIFO output status flag signal. Defaults to EMPTY for the FIFO selected by the FIFOADR[2:0] pins.
13	20	IFCLK	I/O/Z	Z	<b>Interface Clock</b> , used for synchronously clocking data into or out of the slave FIFOs. IFCLK also serves as a timing reference for all slave FIFO control signals. When using the internal clock reference (IFCONFIG.7=1) the IFCLK pin can be configured to output 30/48 MHz by setting bits IFCONFIG.5 and IFCONFIG.6. IFCLK may be inverted by setting the bit IFCONFIG.4=1. Programmable polarity.
14	21	Reserved	Input	N/A	<b>Reserved.</b> Must be connected to ground.
44	51	WAKEUP	Input	N/A	<b>USB Wakeup.</b> If the SX2 is in suspend, asserting this pin starts up the oscillator and interrupts the SX2 to allow it to exit the suspend mode. During normal operation, holding WAKEUP asserted inhibits the SX2 chip from suspending. This pin has programmable polarity (POLAR.7).
15	22	SCL	OD	Z	<b>I<sup>2</sup>C Clock.</b> Connect to V <sub>CC</sub> with a 2.2K-10 KΩ resistor, even if no I <sup>2</sup> C EEPROM is attached.
16	23	SDA	OD	Z	<b>I<sup>2</sup>C Data.</b> Connect to V <sub>CC</sub> with a 2.2K-10 KΩ resistor, even if no I <sup>2</sup> C EEPROM is attached.
55	6	V <sub>CC</sub>	Power	N/A	<b>V<sub>CC</sub>.</b> Connect to 3.3 V power source.
7	14	V <sub>CC</sub>	Power	N/A	<b>V<sub>CC</sub>.</b> Connect to 3.3 V power source.
11	18	V <sub>CC</sub>	Power	N/A	<b>V<sub>CC</sub>.</b> Connect to 3.3 V power source.
17	24	V <sub>CC</sub>	Power	N/A	<b>V<sub>CC</sub>.</b> Connect to 3.3 V power source.
27	34	V <sub>CC</sub>	Power	N/A	<b>V<sub>CC</sub>.</b> Connect to 3.3 V power source.
32	39	V <sub>CC</sub>	Power	N/A	<b>V<sub>CC</sub>.</b> Connect to 3.3 V power source.
43	50	V <sub>CC</sub>	Power	N/A	<b>V<sub>CC</sub>.</b> Connect to 3.3 V power source.
53	4	GND	Ground	N/A	<b>Connect to ground.</b>
56	7	GND	Ground	N/A	<b>Connect to ground.</b>
10	17	GND	Ground	N/A	<b>Connect to ground.</b>
12	19	GND	Ground	N/A	<b>Connect to ground.</b>
26	33	GND	Ground	N/A	<b>Connect to ground.</b>
28	35	GND	Ground	N/A	<b>Connect to ground.</b>
41	48	GND	Ground	N/A	<b>Connect to ground.</b>

## Register Summary

Table 13. SX2 Register Summary

Hex	Size	Name	Description	D7	D6	D5	D4	D3	D2	D1	D0	Default	Access
General Configuration													
01	1	IFCONFIG	Interface configuration	IFCLKSRC	3048MHZ	IFCLKOE	IFCLKPOL	ASYNC	STANDBY	FLAGD/CS#	DISCON	11001001	bbbbbbbb
02	1	FLAGSAB	FIFO FLAGA and FLAGB assignments	FLAGB3	FLAGB2	FLAGB1	FLAGB0	FLAGA3	FLAGA2	FLAGA1	FLAGA0	00000000	bbbbbbbb
03	1	FLAGSCD	FIFO FLAGC and FLAGD assignments	FLAGD3	FLAGD2	FLAGD1	FLAGD0	FLAGC3	FLAGC2	FLAGC1	FLAGC0	00000000	bbbbbbbb
04	1	POLAR	FIFO polarities	WUPOL	0	PKTEND	SLOE	SLRD	SLWR	EF	FF	00000000	bbbrrrrb
05	1	REVID	Chip revision	Major	Major	Major	Major	minor	minor	minor	minor	xxxxxxx	rrrrrrr
Endpoint Configuration <sup>[11]</sup>													
06	1	EP2CFG	Endpoint 2 configuration	VALID	dir	TYPE1	TYPE0	SIZE	STALL	BUF1	BUF0	10100010	bbbbbbbb
07	1	EP4CFG	Endpoint 4 configuration	VALID	dir	TYPE1	TYPE0	0	STALL	0	0	10100000	bbbrbrrr
08	1	EP6CFG	Endpoint 6 configuration	VALID	dir	TYPE1	TYPE0	SIZE	STALL	BUF1	BUF0	11100010	bbbbbbbb
09	1	EP8CFG	Endpoint 8 configuration	VALID	dir	TYPE1	TYPE0	0	STALL	0	0	11100000	bbbrbrrr
0A	1	EP2PKTLENH <sup>[12]</sup>	Endpoint 2 packet length H	INFM1	OEP1	ZEROLEN	WORDWIDE	0	PL10	PL9	PL8	00110010	bbbbbbbb
0B	1	EP2PKTLENL	Endpoint 2 packet length L (IN only)	PL7	PL6	PL5	PL4	PL3	PL2	PL1	PL0	00000000	bbbbbbbb
0C	1	EP4PKTLENH <sup>[13]</sup>	Endpoint 4 packet length H	INFM1	OEP1	ZEROLEN	WORDWIDE	0	0	PL9	PL8	00110010	bbbbbbbb
0D	1	EP4PKTLENL	Endpoint 4 packet length L (IN only)	PL7	PL6	PL5	PL4	PL3	PL2	PL1	PL0	00000000	bbbbbbbb
0E	1	EP6PKTLENH <sup>[14]</sup>	Endpoint 6 packet length H	INFM1	OEP1	ZEROLEN	WORDWIDE	0	PL10	PL9	PL8	00110010	bbbbbbbb
0F	1	EP6PKTLENL	Endpoint 6 packet length L (IN only)	PL7	PL6	PL5	PL4	PL3	PL2	PL1	PL0	00000000	bbbbbbbb
10	1	EP8PKTLENH <sup>[15]</sup>	Endpoint 8 packet length H	INFM1	OEP1	ZEROLEN	WORDWIDE	0	0	PL9	PL8	00110010	bbbbbbbb
11	1	EP8PKTLENL	Endpoint 8 packet length L (IN only)	PL7	PL6	PL5	PL4	PL3	PL2	PL1	PL0	00000000	bbbbbbbb
12	1	EP2PFH	EP2 programmable Flag H	DECIS	PKTSTAT	IN: PKTS[2] OUT:PFC12	IN: PKTS[1] OUT:PFC11	IN: PKTS[0] OUT:PFC10	0	PFC9	PFC8	10001000	bbbbbbbb
13	1	EP2PFL	EP2 programmable Flag L	PFC7	PFC6	PFC5	PFC4	PFC3	PFC2	PFC1	PFC0	00000000	bbbbbbbb
14	1	EP4PFH	EP4 programmable Flag H	DECIS	PKTSTAT	0	IN: PKTS[1] OUT:PFC10	IN: PKTS[0] OUT:PFC9	0	0	PFC8	10001000	bbbbbbbb
15	1	EP4PFL	EP4 programmable Flag L	PFC7	PFC6	PFC5	PFC4	PFC3	PFC2	PFC1	PFC0	00000000	bbbbbbbb
16	1	EP6PFH	EP6 programmable Flag H	DECIS	PKTSTAT	IN: PKTS[2] OUT:PFC12	IN: PKTS[1] OUT:PFC11	IN: PKTS[0] OUT:PFC10	0	PFC9	PFC8	00001000	bbbbbbbb
17	1	EP6PFL	EP6 programmable Flag L	PFC7	PFC6	PFC5	PFC4	PFC3	PFC2	PFC1	PFC0	00000000	bbbbbbbb
18	1	EP8PFH	EP8 programmable Flag H	DECIS	PKTSTAT	0	IN: PKTS[1] OUT:PFC10	IN: PKTS[0] OUT:PFC9	0	0	PFC8	00001000	bbbbbbbb
19	1	EP8PFL	EP8 programmable Flag L	PFC7	PFC6	PFC5	PFC4	PFC3	PFC2	PFC1	PFC0	00000000	bbbbbbbb

**Notes**

11. Note that the SX2 was not designed to support dynamic modification of these endpoint configuration registers. If your applications need the ability to change endpoint configurations after the device has already enumerated with a specific configuration, expect some delay in being able to access the FIFOs after changing the configuration. For example, after writing to EP2PKTLENH, you must wait for at least 35 μs measured from the time the READY signal is asserted before writing to the FIFO. This delay time varies for different registers and is not characterized, because the SX2 was not designed for this dynamic change of endpoint configuration registers.

12. **Errata:** When reading from the SX2 EPxPKTLENH register for endpoints 4, 6, and 8, the lower nibble is returned with an incorrect value. For more information, refer "Errata" on page 44.

13. **Errata:** When reading from the SX2 EPxPKTLENH register for endpoints 4, 6, and 8, the lower nibble is returned with an incorrect value. For more information, refer "Errata" on page 44.

14. **Errata:** When reading from the SX2 EPxPKTLENH register for endpoints 4, 6, and 8, the lower nibble is returned with an incorrect value. For more information, refer "Errata" on page 44.

15. **Errata:** When reading from the SX2 EPxPKTLENH register for endpoints 4, 6, and 8, the lower nibble is returned with an incorrect value. For more information, refer "Errata" on page 44.

Table 13. SX2 Register Summary (continued)

Hex	Size	Name	Description	D7	D6	D5	D4	D3	D2	D1	D0	Default	Access
1A	1	EP2ISOINPKTS	EP2 (if ISO) IN packets per frame (1-3)	0	0	0	0	0	0	INPPF1	INPPF0	00000001	bbbbbbbb
1B	1	EP4ISOINPKTS	EP4 (if ISO) IN packets per frame (1-3)	0	0	0	0	0	0	INPPF1	INPPF0	00000001	bbbbbbbb
1C	1	EP6ISOINPKTS	EP6 (if ISO) IN packets per frame (1-3)	0	0	0	0	0	0	INPPF1	INPPF0	00000001	bbbbbbbb
1D	1	EP8ISOINPKTS	EP8 (if ISO) IN packets per frame (1-3)	0	0	0	0	0	0	INPPF1	INPPF0	00000001	bbbbbbbb
		FLAGS											
1E	1	EP24FLAGS	Endpoints 2,4 FIFO Flags	0	EP4PF	EP4EF	EP4FF	0	EP2PF	EP2EF	EP2FF	00100010	rrrrrrrr
1F	1	EP68FLAGS	Endpoints 6,8 FIFO Flags	0	EP8PF	EP8EF	EP8FF	0	EP6PF	EP6EF	EP6FF	01100110	rrrrrrrr
		INPKTEND/FLUSH <sup>16</sup>											
20	1	INPKTEND/FLUSH	Force packet end / Flush FIFOs	FIFO8	FIFO6	FIFO4	FIFO2	EP3	EP2	EP1	EP0	00000000	wwwwwwww
		USB Configuration											
2A	1	USBFRAMEH	USB frame count H	0	0	0	0	0	FC10	FC9	FC8	xxxxxxx	rrrrrrrr
2B	1	USBFRAMEL	USB frame count L	FC7	FC6	FC5	FC4	FC3	FC2	FC1	FC0	xxxxxxx	rrrrrrrr
2C	1	MICROFRAME	Microframe count, 0-7	0	0	0	0	0	MF2	MF1	MF0	xxxxxxx	rrrrrrrr
2D	1	FNADDR	USB function address	HSGRANT	FA6	FA5	FA4	FA3	FA2	FA1	FA0	00000000	rrrrrrrr
		Interrupts											
2E	1	INTENABLE	Interrupt enable	SETUP	EP0BUF	FLAGS	1	1	ENUMOK	BUS ACTIVITY	READY	11111111	bbbbbbbb
		Descriptor											
30	500	DESC	Descriptor RAM	d7	d6	d5	d4	d3	d2	d1	d0	xxxxxxx	wwwwwwww
		Endpoint 0											
31	64	EP0BUF	Endpoint 0 buffer	d7	d6	d5	d4	d3	d2	d1	d0	xxxxxxx	bbbbbbbb
32	8/1	SETUP	Endpoint 0 setup data/stall	d7	d6	d5	d4	d3	d2	d1	d0	xxxxxxx	bbbbbbbb
33	1	EP0BC	Endpoint 0 Byte count	d7	d6	d5	d4	d3	d2	d1	d0	xxxxxxx	bbbbbbbb
		Un-Indexed Register control											
3A	1		Un-Indexed register low byte pointer	a7	a6	a5	a4	a3	a2	a1	a0		
3B	1		Un-Indexed register high byte pointer	a7	a6	a5	a4	a3	a2	a1	a0		
3C	1		Un-Indexed register data	d7	d6	d5	d4	d3	d2	d1	d0		
Address	Un-Indexed Registers in XDATA Space												
0xE609		FIFOPINPOLAR	FIFO interface pins polarity	0	0	PKTEND	SLOE	SLRD	SLWR	EF	FF	00000000	rrbbbbb
0xE683		TOGCTL	Data toggle control	Q	S	R	IO	EP3	EP2	EP1	EP0	xxxxxxx	rbbbbbb

Note

16. Note that the SX2 was not designed to support dynamic modification of the INPKTEND/FLUSH register. If your applications need the ability to change endpoint configurations or access the INPKTEND register after the device has already enumerated with a specific configuration, expect some delay in being able to access the FIFOs after changing this register. After writing to INPKTEND/FLUSH, you must wait for at least 85 μs measured from the time the Ready signal is asserted before writing to the FIFO. This delay time varies for different registers and is not characterized, because the SX2 was not designed for this dynamic change of endpoint configuration registers.

**IFCONFIG Register 0x01**

IFCONFIG								0x01
Bit #	7	6	5	4	3	2	1	0
Bit Name	IFCLKSRC	3048 MHZ	IFCLKOE	IFCLKPOL	ASYNC	STANDBY	FLAGD/CS#	DISCON
Read/Write	R/W	R/W	R/W	R/W	R/W	R/W	R/W	R/W
Default	1	1	0	0	1	0	0	1

**Bit 7: IFCLKSRC**

This bit selects the clock source for the FIFOs. If IFCLKSRC = 0, the external clock on the IFCLK pin is selected. If IFCLKSRC = 1 (default), an internal 30 or 48 MHz clock is used.

**Bit 6: 3048 MHZ**

This bit selects the internal FIFO clock frequency. If 3048 MHZ = 0, the internal clock frequency is 30 MHz. If 3048 MHZ = 1 (default), the internal clock frequency is 48 MHz.

**Bit 5: IFCLKOE**

This bit selects if the IFCLK pin is driven. If IFCLKOE = 0 (default), the IFCLK pin is floated. If IFCLKOE = 1, the IFCLK pin is driven.

**Bit 4: IFCLKPOL**

This bit controls the polarity of the IFCLK signal.

- When IFCLKPOL = 0, the clock has the polarity shown in all the timing diagrams in this data sheet (rising edge is the activating edge).
- When IFCLKPOL = 1, the clock is inverted (in some cases may help with satisfying data setup times).

**Bit 3: ASYNC**

This bit controls whether the FIFO interface is synchronous or asynchronous. When ASYNC = 0, the FIFOs operate synchronously. In synchronous mode, a clock is supplied either internally

or externally on the IFCLK pin, and the FIFO control signals function as read and write enable signals for the clock signal.

When ASYNC = 1 (default), the FIFOs operate asynchronously. No clock signal input to IFCLK is required, and the FIFO control signals function directly as read and write strobes.

**Bit 2: STANDBY**

This bit instructs the SX2 to enter a low power mode. When STANDBY=1, the SX2 enters a low power mode by turning off its oscillator. The external master should write this bit after it receives a bus activity interrupt (indicating that the host has signaled a USB suspend condition). If SX2 is disconnected from the USB bus, the external master can write this bit at any time to save power. When suspended, the SX2 is awakened either by resumption of USB bus activity or by assertion of its WAKEUP pin.

**Bit 1: FLAGD/CS#**

This bit controls the function of the FLAGD/CS# pin. When FLAGD/CS# = 0 (default), the pin operates as a slave chip select. If FLAGD/CS# = 1, the pin operates as FLAGD.

**Bit 0: DISCON**

This bit controls whether the internal pull up resistor connected to D+ is pulled high or floating. When DISCON = 1 (default), the pull up resistor is floating simulating a USB unplug. When DISCON=0, the pull up resistor is pulled high signaling a USB connection.

**FLAGSAB/FLAGSCD Registers 0x02/0x03**

The SX2 has four FIFO flags output pins: FLAGA, FLAGB, FLAGC, and FLAGD.

FLAGSAB								0x02
Bit #	7	6	5	4	3	2	1	0
Bit Name	FLAGB3	FLAGB2	FLAGB1	FLAGB0	FLAGA3	FLAGA2	FLAGA1	FLAGA0
Read/Write	R/W	R/W	R/W	R/W	R/W	R/W	R/W	R/W
Default	0	0	0	0	0	0	0	0

FLAGSCD								0x03
Bit #	7	6	5	4	3	2	1	0
Bit Name	FLAGD3	FLAGD2	FLAGD1	FLAGD0	FLAGC3	FLAGC2	FLAGC1	FLAGC0
Read/Write	R/W	R/W	R/W	R/W	R/W	R/W	R/W	R/W
Default	0	0	0	0	0	0	0	0

These flags can be programmed to represent various FIFO flags using four select bits for each FIFO. The 4-bit coding for all four flags is the same, as shown in Table 14.

**Table 14. FIFO Flag 4-bit Coding**

FLAGx3	FLAGx2	FLAGx1	FLAGx0	Pin Function
0	0	0	0	FLAGA = PF, FLAGB = FF, FLAGC = EF, FLAGD = CS# (actual FIFO is selected by FIFOADR[2:0] pins)
0	0	0	1	Reserved
0	0	1	0	Reserved
0	0	1	1	Reserved
0	1	0	0	EP2 PF
0	1	0	1	EP4 PF
0	1	1	0	EP6 PF
0	1	1	1	EP8 PF
1	0	0	0	EP2 EF
1	0	0	1	EP4 EF
1	0	1	0	EP6 EF
1	0	1	1	EP8 EF
1	1	0	0	EP2 FF
1	1	0	1	EP4 FF
1	1	1	0	EP6 FF
1	1	1	1	EP8 FF

For the default (0000) selection, the four FIFO flags are fixed-function as shown in the first table entry; the input pins FIFOADR[2:0] select to which of the four FIFOs the flags correspond. These pins are decoded as shown in Table 3 on page 6.

The other (non-zero) values of FLAGx[3:0] allow the designer to configure the four flag outputs FLAGA-FLAGD independently to correspond to any flag-Programmable, Full, or Empty-from any of the four endpoint FIFOs. This allows each flag to be assigned to any of the four FIFOs, including those not currently selected by the FIFOADR [2:0] pins. For example, the external master could be filling the EP2IN FIFO with data while also checking the empty flag for the EP4OUT FIFO.

**POLAR Register 0x04**

This register controls the polarities of FIFO pin signals and the WAKEUP pin.

POLAR	0x04							
Bit #	7	6	5	4	3	2	1	0
Bit Name	WUPOL	0	PKTEND	SLOE	SLRD	SLWR	EF	FF
Read/Write	R/W	R/W	R/W	R	R	R	R/W	R/W
Default	0	0	0	0	0	0	0	0

*Bit 7: WUPOL*

This flag sets the polarity of the WAKEUP pin. If WUPOL = 0 (default), the polarity is active LOW. If WUPOL=1, the polarity is active HIGH.

*Bit 5: PKTEND*

This flag selects the polarity of the PKTEND pin. If PKTEND = 0 (default), the polarity is active LOW. If PKTEND = 1, the polarity is active HIGH.

*Bit 4: SLOE*

This flag selects the polarity of the SLOE pin. If SLOE = 0 (default), the polarity is active LOW. If SLOE = 1, the polarity is active HIGH. This bit can only be changed by using the EEPROM configuration load.

*Bit 3: SLRD*

This flag selects the polarity of the SLRD pin. If SLRD = 0 (default), the polarity is active LOW. If SLRD = 1, the polarity is active HIGH. This bit can only be changed by using the EEPROM configuration load.

*SLWR Bit 2*

This flag selects the polarity of the SLWR pin. If SLWR = 0 (default), the polarity is active LOW. If SLWR = 1, the polarity is active HIGH. This bit can only be changed by using the EEPROM configuration load.

*EF Bit 1*

This flag selects the polarity of the EF pin (FLAGA/B/C/D). If EF = 0 (default), the EF pin is pulled low when the FIFO is empty. If EF = 1, the EF pin is pulled HIGH when the FIFO is empty.

*FF Bit 0*

This flag selects the polarity of the FF pin (FLAGA/B/C/D). If FF = 0 (default), the FF pin is pulled low when the FIFO is full. If FF = 1, the FF pin is pulled HIGH when the FIFO is full.

Note that bits 2(SLWR), 3(SLRD) and 4 (SLOE) are READ only bits and cannot be set by the external master or the EEPROM. On power up, these bits are set to active low polarity. To change the polarity after the device is powered-up, the external master must access the previously undocumented (un-indexed) SX2 register located at XDATA space at 0xE609. This register has exact same bit definition as the POLAR register except that bits 2, 3 and 4 defined as SLWR, SLRD, and SLOE respectively are Read/Write bits. Following is the sequence of events that the master should perform for setting this register to 0x1C (setting bits 4, 3, and 2):

1. Send Low Byte of the register (0x09)
  - a. Command address write of address 0x3A
  - b. Command data write of upper nibble of the Low Byte of Register Address (0x00)
  - c. Command data write of lower nibble of the Low Byte of Register Address (0x09)
2. Send High Byte of the register (0xE6)
  - d. Command address write of address 0x3B
  - e. Command data write of upper nibble of the High Byte of Register Address (0x0E)

- f. Command data write of lower nibble of the High Byte of Register Address (0x06)
- 3. Send the actual value to write to the register (in this case 0x1C)
  - g. Command address write of address 0x3C
  - h. Command data write of upper nibble of the register value (0x01)
  - i. Command data write of lower nibble of the register value (0x0C)

To avoid altering any other bits of the FIFOPINPOLAR register (0xE609) inadvertently, the external master must do a read (from POLAR register), modify the value to set/clear appropriate bits and write the modified value to FIFOPINPOLAR register. The external master may read from the POLAR register using the command read protocol as stated in [Command Protocol](#) on page 7. Modify the value with the appropriate bit set to change the polarity as needed and write this modified value to the FIFOPINPOLAR register.

**REVID Register 0x05**

These register bits define the silicon revision.

REVID	0x05							
Bit #	7	6	5	4	3	2	1	0
Bit Name	Major	Major	Major	Major	Minor	Minor	Minor	Minor
Read/Write	R/W	R/W	R/W	R/W	R/W	R/W	R/W	R/W
Default	X	X	X	X	X	X	X	X

The upper nibble is the major revision. The lower nibble is the minor revision. For example: if REVID = 0x11, then the silicon revision is 1.1.

**EPxCFG Register 0x06–0x09**

These registers configure the large, data-handling SX2 endpoints, EP2, 4, 6, and 8. [Figure 3](#) on page 11 shows the configuration choices for these endpoints. Shaded blocks group endpoint buffers for double-, triple-, or quad-buffering. The endpoint direction is set independently—any shaded block can have any direction.

EPxCFG	0x06, 0x08							
Bit #	7	6	5	4	3	2	1	0
Bit Name	VALID	DIR	TYPE1	TYPE0	SIZE	STALL	BUF1	BUF0
Read/Write	R/W	R/W	R/W	R/W	R/W	R/W	R/W	R/W
Default	1	0	1	0	0	0	1	0

*Bit 7: VALID*

The external master sets VALID = 1 to activate an endpoint, and VALID = 0 to deactivate it. All SX2 endpoints default to valid. An endpoint whose VALID bit is 0 does not respond to any USB traffic. (**Note** When setting VALID=0, use default values for all other bits.)

**Note**

17. **Errata:** When reading from the SX2 EPxPKTLENH register for endpoints 4, 6, and 8, the lower nibble is returned with an incorrect value. For more information, refer “Errata” on page 44.

*Bit 6: DIR*

0 = OUT, 1 = IN. Defaults for EP2/4 are DIR = 0, OUT, and for EP6/8 are DIR = 1, IN.

*Bit [5,4]: TYPE1, TYPE0*

These bits define the endpoint type, as shown in [Table 15](#). The TYPE bits apply to all the endpoint configuration registers. All SX2 endpoints except EP0 default to BULK.

**Table 15. Endpoint Type**

TYPE1	TYPE0	Endpoint Type
0	0	Invalid
0	1	Isochronous
1	0	Bulk (Default)
1	1	Interrupt

*Bit 3: SIZE*

0 = 512 bytes (default), 1 = 1024 bytes.

Endpoints 4 and 8 can only be 512 bytes and is a read only bit. The size of endpoints 2 and 6 is selectable.

*Bit 2: STALL*

Each bulk endpoint (IN or OUT) has a STALL bit (bit 2). If the external master sets this bit, any requests to the endpoint return a STALL handshake rather than ACK or NAK. The Get Status-Endpoint Request returns the STALL state for the endpoint indicated in byte 4 of the request. Note that bit 7 of the endpoint number EP (byte 4) specifies direction.

*Bit [1,0]: BUF1, BUF0*

For EP2 and EP6 the depth of endpoint buffering is selected via BUF1:0, as shown in [Table 16](#). For EP4 and EP8 the buffer is internally set to double buffered and are read only bits.

**Table 16. Endpoint Buffering**

BUF1	BUF0	Buffering
0	0	Quad
0	1	Invalid <sup>[1]</sup>
1	0	Double
1	1	Triple

1. Setting the endpoint buffering to invalid causes improper buffer allocation.

**EPxPKTLENH/L Registers 0x0A–0x11** <sup>[17]</sup>

The external master can use these registers to set smaller packet sizes than the physical buffer size (refer to the previously described EPxCFG registers). The default packet size is 512 bytes for all endpoints. Note that EP2 and EP6 can have maximum sizes of 1024 bytes, and EP4 and EP8 can have maximum sizes of 512 bytes, to be consistent with the endpoint structure.

In addition, the EPxPKTLENH register has four other endpoint configuration bits.

EPxPKTLENL								0x0B, 0x0D, 0x0F, 0x11	
Bit #	7	6	5	4	3	2	1	0	
Bit Name	PL7	PL6	PL5	PL4	PL3	PL2	PL1	PL0	
Read/Write	R/W	R/W	R/W	R/W	R/W	R/W	R/W	R/W	
Default	0	0	0	0	0	0	0	0	

EP2PKTLENH, EP6PKTLENH								0x0A, 0x0E	
Bit #	7	6	5	4	3	2	1	0	
Bit Name	INFM1	OEP1	ZEROLEN	WORDWIDE	0	PL10	PL9	PL8	
Read/Write	R/W	R/W	R/W	R/W	R/W	R/W	R/W	R/W	
Default	0	0	1	1	0	0	1	0	

EP4PKTLENH, EP8PKTLENH								0x0C, 0x10	
Bit #	7	6	5	4	3	2	1	0	
Bit Name	INFM1	OEP1	ZEROLEN	WORDWIDE	0	0	PL9	PL8	
Read/Write	R/W	R/W	R/W	R/W	R/W	R/W	R/W	R/W	
Default	0	0	1	1	0	0	1	0	

**Bit 7: INFM1 EPxPKTLENH.7**

When the external master sets INFM = 1 in an endpoint configuration register, the FIFO flags for that endpoint become valid one sample earlier than when the full condition occurs. These bits take effect only when the FIFOs are operating synchronously according to an internally or externally supplied clock. Having the FIFO flag indications one sample early simplifies some synchronous interfaces. This applies only to IN endpoints. Default is INFM1 = 0.

**Bit 6: OEP1 EPxPKTLENH.6**

When the external master sets an OEP = 1 in an endpoint configuration register, the FIFO flags for that endpoint become valid one sample earlier than when the empty condition occurs. These bits take effect only when the FIFOs are operating synchronously according to an internally or externally supplied clock. Having the FIFO flag indications one sample early simplifies some synchronous interfaces. This applies only to OUT endpoints. Default is OEP1 = 0.

**Bit 5: ZEROLEN EPxPKTLENH.5**

When ZEROLEN = 1 (default), a zero length packet is sent when the PKTEND pin is asserted and there are no bytes in the current packet. If ZEROLEN = 0, then a zero length packet is not sent under these conditions.

**Bit 4: WORDWIDE EPxPKTLENH.4**

This bit controls whether the data interface is 8 or 16 bits wide. If WORDWIDE = 0, the data interface is eight bits wide, and

FD[15:8] have no function. If WORDWIDE = 1 (default), the data interface is 16 bits wide.

**Bit [2..0]: PL[X:0] Packet Length Bits**

The default packet size is 512 bytes for all endpoints.

**EPxPFH/L Registers 0x12–0x19**

The Programmable Flag registers control when the PF goes active for each of the four endpoint FIFOs: EP2, EP4, EP6, and EP8. The EPxPFH/L fields are interpreted differently for the high speed operation and full speed operation and for OUT and IN endpoints.

Following is the register bit definition for high speed operation and for full speed operation (when endpoint is configured as an isochronous endpoint).

Full Speed ISO and High Speed Mode: EP2PFL, EP4PFL, EP6PFL, EP8PFL							0x13, 0x15, 0x17, 0x19	
Bit #	7	6	5	4	3	2	1	0
Bit Name	PFC7	PFC6	PFC5	PFC4	PFC3	PFC2	PFC1	PFC0
Read/Write	R/W	R/W	R/W	R/W	R/W	R/W	R/W	R/W
Default	0	0	0	0	0	0	0	0

Full Speed ISO and High Speed Mode: EP4PFH, EP8PFH							0x14, 0x18	
Bit #	7	6	5	4	3	2	1	0
Bit Name	DECIS	PKTSTAT	0	IN: PKTS[1] OUT: PFC10	IN: PKTS[0] OUT: PFC9	0	0	PFC8
Read/Write	R/W	R/W	R/W	R/W	R/W	R/W	R/W	R/W
Default	1	0	0	0	1	0	0	0

Full Speed ISO and High Speed Mode: EP2PFH, EP6PFH							0x12, 0x16	
Bit #	7	6	5	4	3	2	1	0
Bit Name	DECIS	PKT-STAT	IN: PKTS[2] OUT: PFC12	IN: PKTS[1] OUT: PFC11	IN: PKTS[0] OUT: PFC10	0	PFC9	PFC8
Read/Write	R/W	R/W	R/W	R/W	R/W	R/W	R/W	R/W
Default	1	0	0	0	1	0	0	0

Following is the bit definition for the same register when the device is operating at full speed and the endpoint is not configured as isochronous endpoint.

Full Speed Non-ISO Mode: EP2PFL, EP4PFL, EP6PFL, EP8PFL							0x13, 0x15, 0x17, 0x19	
Bit #	7	6	5	4	3	2	1	0
Bit Name	IN: PKTS[1] OUT: PFC7	IN: PKTS[0] OUT: PFC6	PFC5	PFC4	PFC3	PFC2	PFC1	PFC0
Read/Write	R/W	R/W	R/W	R/W	R/W	R/W	R/W	R/W
Default	0	0	0	0	0	0	0	0

Full Speed Non-ISO Mode: EP2PFH, EP6PFH								0x12, 0x16	
Bit #	7	6	5	4	3	2	1	0	
Bit Name	DECIS	PKT-STAT	OUT: PFC12	OUT: PFC11	OUT: PFC10	0	PFC9	IN: PKTS[2] OUT: PFC8	
Read/Write	R/W	R/W	R/W	R/W	R/W	R/W	R/W	R/W	
Default	1	0	0	0	1	0	0	0	

Full Speed Non-ISO Mode: EP4PFH, EP8PFH								0x14, 0x18	
Bit #	7	6	5	4	3	2	1	0	
Bit Name	DECIS	PKT-STAT	0	OUT: PFC10	OUT: PFC9	0	0	PFC8	
Read/Write	R/W	R/W	R/W	R/W	R/W	R/W	R/W	R/W	
Default	1	0	0	0	1	0	0	0	

**DECIS: EPxPFH.7**

If DECIS = 0, then PF goes high when the byte count is equal to or less than what is defined in the PF registers. If DECIS = 1 (default), then PF goes high when the byte count equal to or greater than what is set in the PF register. For OUT endpoints, the byte count is the total number of bytes in the FIFO that are available to the external master. For IN endpoints, the byte count is determined by the PKSTAT bit.

**PKSTAT: EPxPFH.6**

For IN endpoints, the PF can apply to either the entire FIFO, comprising multiple packets, or only to the current packet being filled. If PKTSTAT = 0 (default), the PF refers to the entire IN endpoint FIFO. If PKTSTAT = 1, the PF refers to the number of bytes in the current packet.

PKTSTAT	PF applies to	EPnPFH:L format
0	Number of committed packets + current packet bytes	PKTS[] and PFC[]
1	Current packet bytes only	PFC[ ]

**IN: PKTS(2:0)/OUT: PFC[12:10]: EPxPFH[5:3]**

These three bits have a different meaning, depending on whether this is an IN or OUT endpoint.

**IN Endpoints**

If IN endpoint, the meaning of this EPxPFH[5:3] bits depend on the PKTSTAT bit setting. When PKTSTAT = 0 (default), the PF considers when there are PKTS packets plus PFC bytes in the

FIFO. PKTS[2:0] determines how many packets are considered, according to Table 17.

**Table 17. PKTS Bits**

PKTS2	PKTS1	PKTS0	Number of Packets
0	0	0	0
0	0	1	1
0	1	0	2
0	1	1	3
1	0	0	4

When PKTSTAT = 1, the PF considers when there are PFC bytes in the FIFO, no matter how many packets are in the FIFO. The PKTS[2:0] bits are ignored.

**OUT Endpoints**

The PF considers when there are PFC bytes in the FIFO regardless of the PKTSTAT bit setting.

**EPxISOINPKTS Registers 0x1A–0x1D**

EP2ISOINPKTS, EP4ISOINPKTS, EP6ISOINPKTS, EP8ISOINPKTS							0x1A, 0x1B, 0x1C, 0x1D	
Bit #	7	6	5	4	3	2	1	0
Bit Name	0	0	0	0	0	INPPF2	INPPF1	INPPF0
Read/Write	R/W	R/W	R/W	R/W	R/W	R/W	R/W	R/W
Default	0	0	0	0	0	0	0	1

For ISOCRONOUS IN endpoints only, these registers determine the number of packets per frame (only one per frame for full speed mode) or microframe (up to three per microframe for high speed mode), according to the following table.

**Table 18. EPxISOINPKTS**

INPPF1	INPPF0	Packets
0	0	Invalid
0	1	1 (default)
1	0	2
1	1	3

**EPxxFLAGS Registers 0x1E–0x1F**

The EPxxFLAGS provide an alternate way of checking the status of the endpoint FIFO flags. If enabled, the SX2 can interrupt the external master when a flag is asserted, and the external master can read these two registers to determine the state of the FIFO flags. If the INFM1 and/or OEP1 bits are set, then the EPxEF and EPxFF bits are actually empty +1 and full -1.

EP24FLAGS								0x1E	
Bit #	7	6	5	4	3	2	1	0	
Bit Name	0	EP4PF	EP4EF	EP4FF	0	EP2PF	EP2EF	EP2FF	
Read/Write	R/W	R/W	R/W	R/W	R/W	R/W	R/W	R/W	
Default	0	0	1	0	0	0	1	0	

EP68FLAGS								0x1F
Bit #	7	6	5	4	3	2	1	0
Bit Name	0	EP8PF	EP8EF	EP8FF	0	EP6PF	EP6EF	EP6FF
Read/Write	R/W	R/W	R/W	R/W	R/W	R/W	R/W	R/W
Default	0	0	1	0	0	0	1	0

**EPxPF Bit 6, Bit 2**

This bit is the current state of endpoint x's programmable flag.

**EPxEF Bit 5, Bit 1**

This bit is the current state of endpoint x's empty flag. EPxEF = 1 if the endpoint is empty.

**EPxFF Bit 4, Bit 0**

This bit is the current state of endpoint x's full flag. EPxFF = 1 if the endpoint is full.

**INPKTEND/FLUSH Register 0x20**

This register allows the external master to duplicate the function of the PKTEND pin. The register also allows the external master to selectively flush endpoint FIFO buffers.

INPKTEND/FLUSH								0x20
Bit #	7	6	5	4	3	2	1	0
Bit Name	FIFO8	FIFO6	FIFO4	FIFO2	EP3	EP2	EP1	EP0
Read/Write	W	W	W	W	W	W	W	W
Default	0	0	0	0	0	0	0	0

**Bit [4..7]: FIFOx**

These bits allows the external master to flush any or all of the endpoint FIFOs selectively. By writing the desired endpoint FIFO bit, SX2 logic flushes the selected FIFO. For example setting bit 7 flushes endpoint 8 FIFO.

**Bit [3..0]: EPx**

These bits are used only for IN transfers. By writing the desired endpoint number (2,4,6 or 8), SX2 logic automatically commits an IN buffer to the USB host. For example, for committing a packet through endpoint 6, set the lower nibble to 6: set bits 1 and 2 high.

**USBFRAMEH/L Registers 0x2A, 0x2B**

Every millisecond, the USB host sends an SOF token indicating "Start of Frame," along with an 11-bit incrementing frame count. The SX2 copies the frame count into these registers at every SOF.

USBFRAMEH								0x2A
Bit #	7	6	5	4	3	2	1	0
Bit Name	0	0	0	0	0	FC10	FC9	FC8
Read/Write	R	R	R	R	R	R	R	R
Default	X	X	X	X	X	X	X	x

USBFRAMEL								0x2B
Bit #	7	6	5	4	3	2	1	0
Bit Name	FC7	FC6	FC5	FC4	FC3	FC2	FC1	FC0
Read/Write	R	R	R	R	R	R	R	R
Default	X	X	X	X	X	X	X	X

One use of the frame count is to respond to the USB SYNC\_FRAME Request. If the SX2 detects a missing or garbled SOF, the SX2 generates an internal SOF and increments USBFRAMEH-USBFRAMEH.

**MICROFRAME Registers 0x2C**

MICROFRAME								0x2C
Bit #	7	6	5	4	3	2	1	0
Bit Name	0	0	0	0	0	MF2	MF1	MF0
Read/Write	R	R	R	R	R	R	R	R
Default	X	X	X	X	X	X	X	x

MICROFRAME contains a count 0-7 that indicates which of the 125 microsecond microframes last occurred.

This register is active only when SX2 is operating in high speed mode (480 Mbits/sec).

**FNADDR Register 0x2D**

During the USB enumeration process, the host sends a device a unique 7-bit address that the SX2 copies into this register. There is normally no reason for the external master to know its USB device address because the SX2 automatically responds only to its assigned address.

FNADDR								0x2D
Bit #	7	6	5	4	3	2	1	0
Bit Name	HSGRANT	FA6	FA5	FA4	FA3	FA2	FA1	FA0
Read/Write	R	R	R	R	R	R	R	R
Default	0	0	0	0	0	0	0	0

Bit 7: HSGRANT, Set to 1 if the SX2 enumerated at high speed. Set to 0 if the SX2 enumerated at full speed.

Bit[6..0]: Address set by the host.

**INTENABLE Register 0x2E**

This register is used to enable/disable the various interrupt sources, and by default all interrupts are enabled.

INTENABLE								0x2E
Bit #	7	6	5	4	3	2	1	0
Bit Name	SETUP	EP0 BUF	FLAG S	1	1	ENUM OK	BUS ACTIVITY	READY
Read/Write	R/W	R/W	R/W	R/W	R/W	R/W	R/W	R/W
Default	1	1	1	1	1	1	1	1

**SETUP Bit 7**

Setting this bit to a 1 enables an interrupt when a setup packet is received from the USB host.

***EP0BUF Bit 6***

Setting this bit to a 1 enables an interrupt when the Endpoint 0 buffer becomes available.

***FLAGS Bit 5***

Setting this bit to a 1 enables an interrupt when an OUT endpoint FIFO's state transitions from empty to not-empty.

***ENUMOK Bit 2***

Setting this bit to a 1 enables an interrupt when SX2 enumeration is complete.

***BUSACTIVITY Bit 1***

Setting this bit to a 1 enables an interrupt when the SX2 detects an absence or presence of bus activity.

***READY Bit 0***

Setting this bit to a 1 enables an interrupt when the SX2 has powered on and performed an internal self-test.

**DESC Register 0x30**

This register address is used to write the 500-byte descriptor RAM. The external master writes two bytes (four command data transfers) to this address corresponding to the length of the descriptor or VID/PID/DID data to be written. The external

master then consecutively writes that number of bytes into the descriptor RAM in nibble format. For complete details, see [Enumeration](#) on page 8.

**EP0BUF Register 0x31**

This register address is used to access the 64-byte Endpoint 0 buffer. The external master can read or write to this register to complete Endpoint 0 data transfers. For complete details, see [Endpoint 0 \[8\]](#) on page 9.

**SETUP Register 0x32**

This register address is used to access the 8-byte setup packet received from the USB host. If the external master writes to this register, it can stall Endpoint 0. For complete details, see [Endpoint 0 \[8\]](#) on page 9.

**EP0BC Register 0x33**

This register address is used to access the byte count of Endpoint 0. For Endpoint 0 OUT transfers, the external master can read this register to get the number of bytes transferred from the USB host. For Endpoint 0 IN transfers, the external master writes the number of bytes in the Endpoint 0 buffer to transfer the bytes to the USB host. For complete details, see [Endpoint 0 \[8\]](#) on page 9.

### Absolute Maximum Ratings

Storage temperature ..... -65 °C to +150 °C  
 Ambient temperature  
 with power supplied ..... 0 °C to +70 °C  
 Supply voltage to ground potential ..... -0.5 V to +4.0 V  
 DC input voltage to any pin ..... 5.25 V  
 DC voltage applied to outputs  
 in High-Z state ..... -0.5 V to  $V_{CC} + 0.5 V$   
 Power dissipation ..... 936 mW

Static discharge voltage ..... > 2000 V

### Operating Conditions

$T_A$  (ambient temperature under bias) ..... 0 °C to +70 °C  
 Supply voltage ..... +3.0 V to +3.6 V  
 Ground voltage ..... 0 V  
 $F_{OSC}$  (oscillator or  
 crystal frequency) ..... 24 MHz  $\pm$  100-ppm Parallel Resonant

### DC Electrical Characteristics

Table 19. DC Characteristics

Parameter	Description	Conditions <sup>[18]</sup>	Min	Typ	Max	Unit
$V_{CC}$	Supply voltage		3.0	3.3	3.6	V
$V_{IH}$	Input high voltage		2	–	5.25	V
$V_{IL}$	Input low voltage		-0.5	–	0.8	V
$I_I$	Input leakage current	$0 < V_{IN} < V_{CC}$	–	–	$\pm 10$	$\mu A$
$V_{OH}$	Output voltage high	$I_{OUT} = 4 \text{ mA}$	2.4	–	–	V
$V_{OL}$	Output voltage low	$I_{OUT} = -4 \text{ mA}$	–	–	0.4	V
$I_{OH}$	Output current high		–	–	4	mA
$I_{OL}$	Output current low		–	–	4	mA
$C_{IN}$	Input pin capacitance	Except D+/D–	–	–	10	pF
		D+/D–	–	–	15	pF
$I_{SUSP}$	Suspend current	Includes 1.5k integrated pull up	–	250	400	$\mu A$
$I_{SUSP}$	Suspend current	Excluding 1.5k integrated pull up	–	30	180	$\mu A$
$I_{CC}$	Supply current	Connected to USB at high speed	–	200	260	mA
		Connected to USB at full speed	–	90	150	mA
$T_{RESET}$	RESET time after valid power	$V_{CC} \text{ min} = 3.0 \text{ V}$	1.91	–	–	mS

### AC Electrical Characteristics

#### USB Transceiver

USB 2.0-certified compliant in full and high speed.

**Note**

18. Specific conditions for  $I_{CC}$  measurements: HS typical 3.3 V, 25°C, 48 MHz; FS typical 3.3 V, 25°C, 48 MHz.

Command Interface

Figure 5. Command Synchronous Read Timing Diagram<sup>[19]</sup>

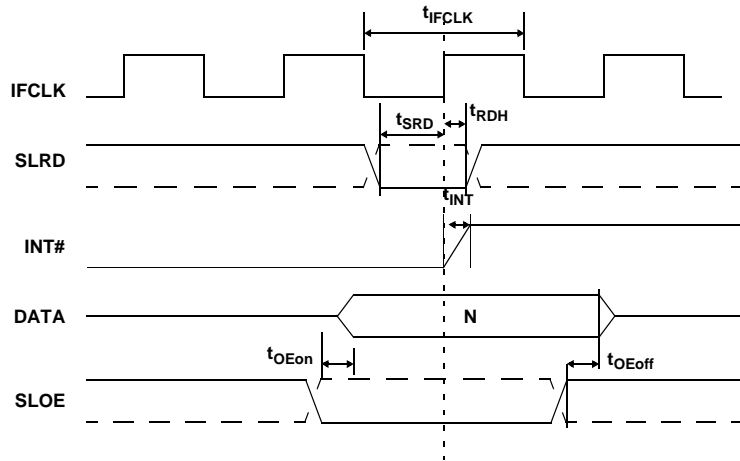

Table 20. Command Synchronous Read Parameters with Internally Sourced IFCLK

Parameter	Description	Min	Max	Unit
$t_{IFCLK}$	IFCLK period	20.83	–	ns
$t_{SRD}$	SLRD to clock setup time	18.7	–	ns
$t_{RDH}$	Clock to SLRD hold time	0	–	ns
$t_{OEon}$	SLOE turn on to FIFO data valid	–	10.5	ns
$t_{OEoff}$	SLOE turn off to FIFO data hold	–	10.5	ns
$t_{INT}$	Clock to INT# output propagation delay	–	9.5	ns

Table 21. Command Synchronous Read with Externally Sourced IFCLK<sup>[20]</sup>

Parameter	Description	Min	Max	Unit
$t_{IFCLK}$	IFCLK period	20	200	ns
$t_{SRD}$	SLRD to clock setup time	12.7	–	ns
$t_{RDH}$	Clock to SLRD hold time	3.7	–	ns
$t_{OEon}$	SLOE turn on to FIFO data valid	–	10.5	ns
$t_{OEoff}$	SLOE turn off to FIFO data hold	–	10.5	ns
$t_{INT}$	Clock to INT# output propagation delay	–	13.5	ns

Notes

- 19. Dashed lines denote signals with programmable polarity.
- 20. Externally sourced IFCLK must not exceed 50 MHz.

Figure 6. Command Synchronous Write Timing Diagram [21]

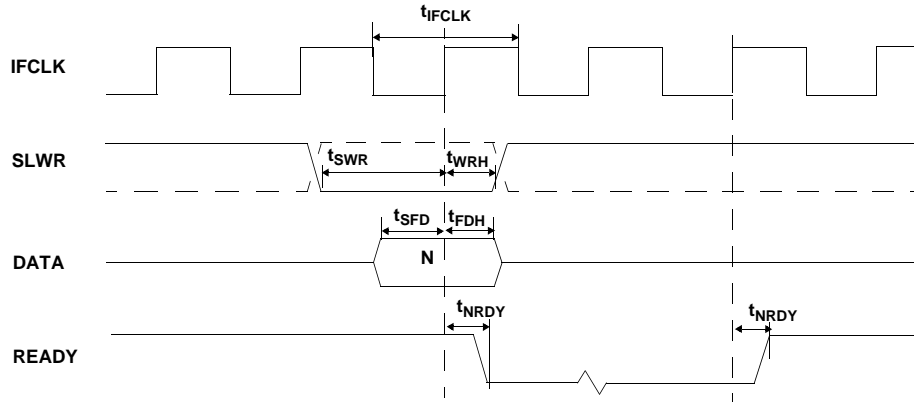

Table 22. Command Synchronous Write Parameters with Internally Sourced IFCLK

Parameter	Description	Min	Max	Unit
$t_{IFCLK}$	IFCLK period	20.83	–	ns
$t_{SWR}$	SLWR to clock setup time	18.1	–	ns
$t_{WRH}$	Clock to SLWR hold time	0	–	ns
$t_{SFD}$	Command data to clock setup time	9.2	–	ns
$t_{FDH}$	Clock to command data hold time	0	–	ns
$t_{NRDY}$	Clock to ready output propagation time	–	9.5	ns

Table 23. Command Synchronous Write Parameters with Externally Sourced IFCLK [22]

Parameter	Description	Min	Max	Unit
$t_{IFCLK}$	IFCLK period	20	200	ns
$t_{SWR}$	SLWR to clock setup time	12.1	–	ns
$t_{WRH}$	Clock to SLWR hold time	3.6	–	ns
$t_{SFD}$	Command data to clock setup time	3.2	–	ns
$t_{FDH}$	Clock to command data hold time	4.5	–	ns
$t_{NRDY}$	Clock to ready output propagation time	–	13.5	ns

Figure 7. Command Asynchronous Read Timing Diagram [21]

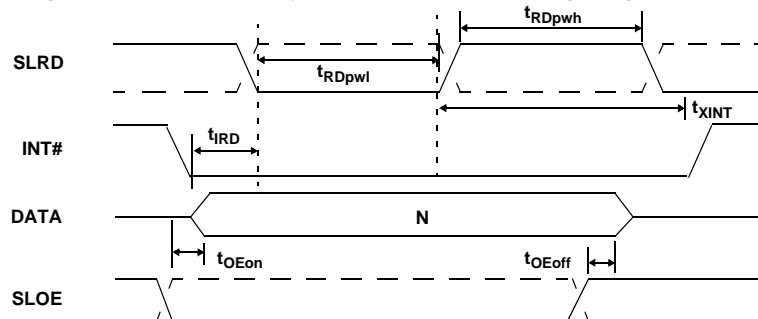

Notes

- 21. Dashed lines denote signals with programmable polarity.
- 22. Externally sourced IFCLK must not exceed 50 MHz.

Table 24. Command Read Parameters

Parameter	Description	Min	Max	Unit
$t_{RDpwl}$	SLRD pulse width low	50	–	ns
$t_{RDpwh}$	SLRD pulse width high	50	–	ns
$t_{IRD}$	INTERRUPT to SLRD	0	–	ns
$t_{XINT}$	SLRD to INTERRUPT	–	70	ns
$t_{OEon}$	SLOE turn on to FIFO data valid	–	10.5	ns
$t_{OEoff}$	SLOE turn off to FIFO data hold	–	10.5	ns

Figure 8. Command Asynchronous Write Timing Diagram<sup>[23]</sup>

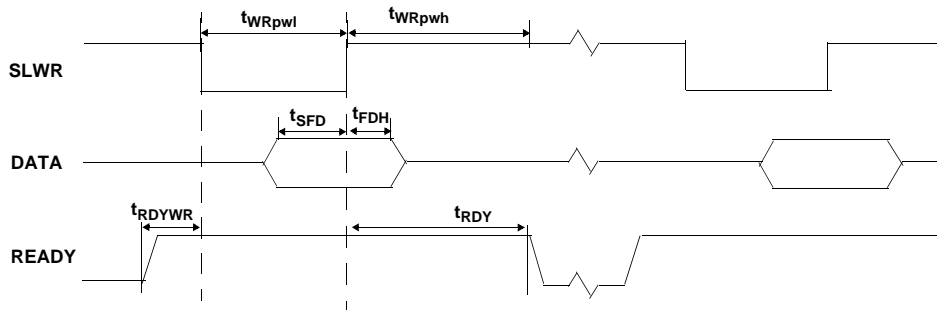
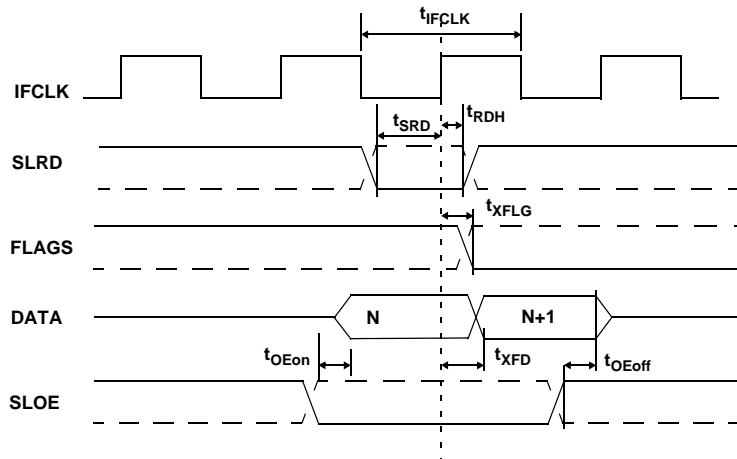

Table 25. Command Write Parameters

Parameter	Description	Min	Max	Unit
$t_{WRpwl}$	SLWR pulse low	50	–	ns
$t_{WRpwh}$	SLWR pulse high	70	–	ns
$t_{SFD}$	SLWR to command data setup time	10	–	ns
$t_{FDH}$	Command data to SLWR hold time	10	–	ns
$t_{RDYWR}$	Ready to SLWR time	0	–	ns
$t_{RDY}$	SLWR to Ready	–	70	ns

FIFO Interface

Figure 9. Slave FIFO Synchronous Read Timing Diagram<sup>[23]</sup>



Note

23. Dashed lines denote signals with programmable polarity.

**Table 26. Slave FIFO Synchronous Read with Internally Sourced IFCLK<sup>[24]</sup>**

Parameter	Description	Min	Max	Unit
$t_{IFCLK}$	IFCLK period	20.83	–	ns
$t_{SRD}$	SLRD to clock setup time	18.7	–	ns
$t_{RDH}$	Clock to SLRD hold time	0	–	ns
$t_{OEon}$	SLOE turn on to FIFO data valid	–	10.5	ns
$t_{OEoff}$	SLOE turn off to FIFO data hold	–	10.5	ns
$t_{XFLG}$	Clock to FLAGS output propagation delay	–	9.5	ns
$t_{XFD}$	Clock to FIFO data output propagation delay	–	11	ns

**Table 27. Slave FIFO Synchronous Read with Externally Sourced IFCLK<sup>[24]</sup>**

Parameter	Description	Min	Max	Unit
$t_{IFCLK}$	IFCLK period	20	200	ns
$t_{SRD}$	SLRD to clock setup time	12.7	–	ns
$t_{RDH}$	Clock to SLRD hold time	3.7	–	ns
$t_{OEon}$	SLOE turn on to FIFO data valid	–	10.5	ns
$t_{OEoff}$	SLOE turn off to FIFO data hold	–	10.5	ns
$t_{XFLG}$	Clock to FLAGS output propagation delay	–	13.5	ns
$t_{XFD}$	Clock to FIFO data output propagation delay	–	15	ns

**Figure 10. Slave FIFO Synchronous Write Timing Diagram<sup>[25]</sup>**

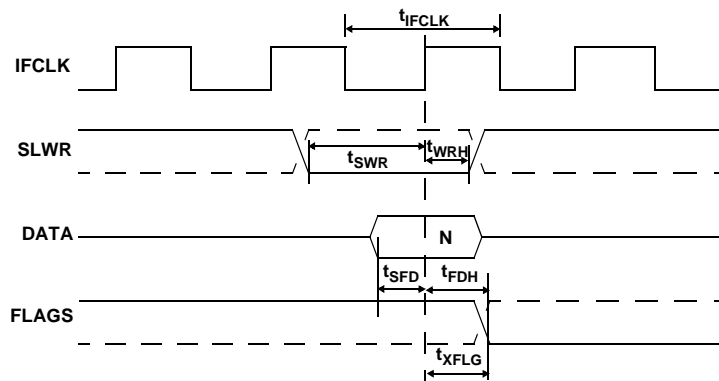

**Table 28. Slave FIFO Synchronous Write Parameters with Internally Sourced IFCLK<sup>[24]</sup>**

Parameter	Description	Min	Max	Unit
$t_{IFCLK}$	IFCLK period	20.83	–	ns
$t_{SWR}$	SLWR to clock setup time	18.1	–	ns
$t_{WRH}$	Clock to SLWR hold time	0	–	ns
$t_{SFD}$	FIFO data to clock setup time	9.2	–	ns
$t_{FDH}$	Clock to FIFO data hold time	0	–	ns
$t_{XFLG}$	Clock to FLAGS output propagation time	–	9.5	ns

**Notes**

- 24. Externally sourced IFCLK must not exceed 50 MHz.
- 25. Dashed lines denote signals with programmable polarity.

**Table 29. Slave FIFO Synchronous Write Parameters with Externally Sourced IFCLK<sup>[26]</sup>**

Parameter	Description	Min	Max	Unit
$t_{IFCLK}$	IFCLK period	20	–	ns
$t_{SWR}$	SLWR to clock setup time	12.1	–	ns
$t_{WRH}$	Clock to SLWR hold time	3.6	–	ns
$t_{SFD}$	FIFO data to clock setup time	3.2	–	ns
$t_{FDH}$	Clock to FIFO data hold time	4.5	–	ns
$t_{XFLG}$	Clock to FLAGS output propagation time	–	13.5	ns

**Figure 11. Slave FIFO Synchronous Packet End Strobe Timing Diagram<sup>[27]</sup>**

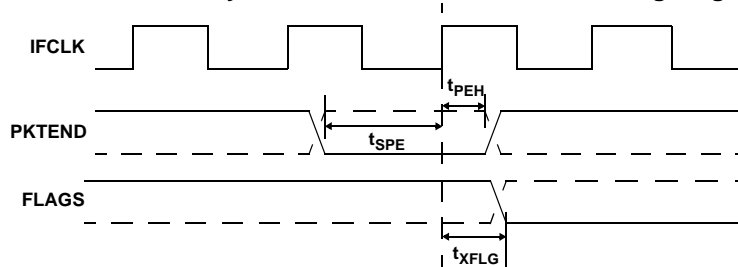

**Table 30. Slave FIFO Synchronous Packet End Strobe Parameters, Internally Sourced IFCLK<sup>[26]</sup>**

Parameter	Description	Min	Max	Unit
$t_{IFCLK}$	IFCLK period	20.83	–	ns
$t_{SPE}$	PKTEND to clock setup time	14.6	–	ns
$t_{PEH}$	Clock to PKTEND hold time	0	–	ns
$t_{XFLG}$	Clock to FLAGS output propagation delay	–	9.5	ns

**Table 31. Slave FIFO Synchronous Packet End Strobe Parameters, Externally Sourced IFCLK<sup>[26]</sup>**

Parameter	Description	Min	Max	Unit
$t_{IFCLK}$	IFCLK period	20	200	ns
$t_{SPE}$	PKTEND to clock setup time	8.6	–	ns
$t_{PEH}$	Clock to PKTEND hold time	2.5	–	ns
$t_{XFLG}$	Clock to FLAGS output propagation delay	–	13.5	ns

There is no specific timing requirement that needs to be met for asserting PKTEND pin. PKTEND can be asserted with the last data value clocked into the FIFOs or thereafter. The only consideration is the setup time  $t_{SPE}$  and the hold time  $t_{PEH}$  must be met.

A specific corner case condition needs attention while using the PKTEND to commit a one byte/word packet. An additional timing requirement must be met when the FIFO is configured to operate in auto mode. Send two packets back to back: a full packet (full

defined as the number of bytes in the FIFO meeting the level set in AUTOINLEN register) committed automatically followed by a short one byte/word packet committed manually using the PKTEND pin. In this case, make sure to assert PKTEND at least one clock cycle after the rising edge that caused the last byte/word to be clocked into the previous auto committed packet. Figure 12 shows this scenario. X is the value the AUTOINLEN register is set to when the IN endpoint is configured to be in auto mode.

**Notes**

- 26. Externally sourced IFCLK must not exceed 50 MHz.
- 27. Dashed lines denote signals with programmable polarity.

Figure 12. Slave FIFO Synchronous Write Sequence and Timing Diagram

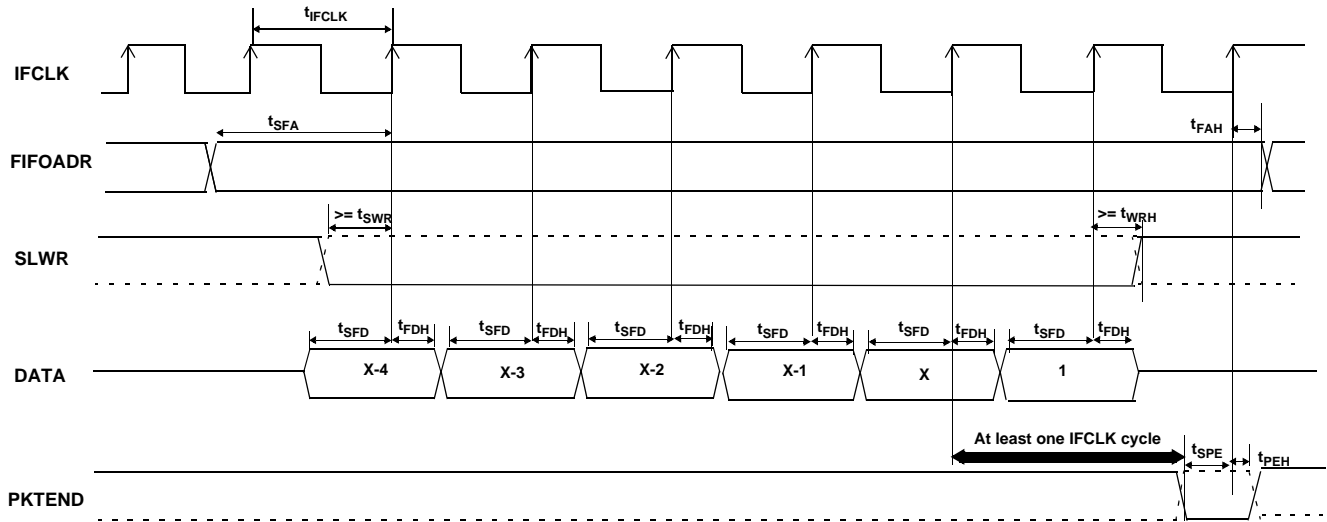

Figure 12 shows a scenario where two packets are being committed. The first packet gets committed automatically when the number of bytes in the FIFO reaches X (value set in AUTOINLEN register) and the second one byte/word short packet being committed manually using PKTEND. Note that there is at least one IFCLK cycle timing between the assertion of PKTEND and clocking of the last byte of the previous packet (causing the packet to be committed automatically). Failing to adhere to this timing, results in the FX2 failing to send the one byte/word short packet.

Figure 13. Slave FIFO Synchronous Address Timing Diagram

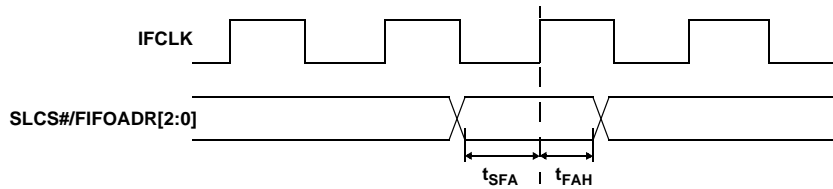

Table 32. Slave FIFO Synchronous Address Parameters<sup>[28]</sup>

Parameter	Description	Min	Max	Unit
$t_{IFCLK}$	Interface clock period	20	200	ns
$t_{SFA}$	FIFOADR[2:0] to clock setup time	25	–	ns
$t_{FAH}$	Clock to FIFOADR[2:0] hold time	10	–	ns

Note

28. Externally sourced IFCLK must not exceed 50 MHz.

Figure 14. Slave FIFO Asynchronous Read Timing Diagram<sup>[29]</sup>

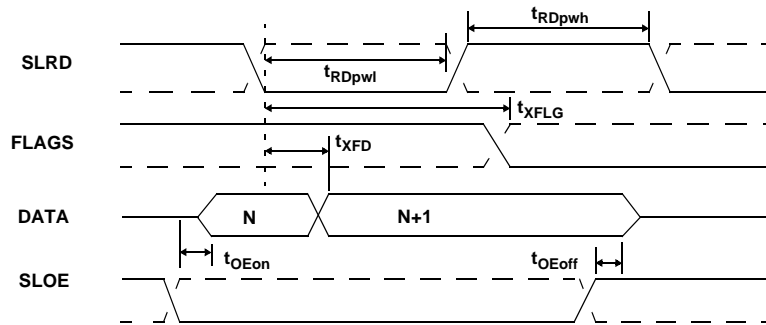

Table 33. Slave FIFO Asynchronous Read Parameters<sup>[30]</sup>

Parameter	Description	Min	Max	Unit
$t_{RDpwl}$	SLRD pulse width low	50	–	ns
$t_{RDpwh}$	SLRD pulse width high	50	–	ns
$t_{XFLG}$	SLRD to FLAGS output propagation delay	–	70	ns
$t_{XFD}$	SLRD to FIFO data output propagation delay	–	15	ns
$t_{OEon}$	SLOE turn on to FIFO data valid	–	10.5	ns
$t_{OEoff}$	SLOE turn off to FIFO data hold	–	10.5	ns

Figure 15. Slave FIFO Asynchronous Write Timing Diagram<sup>[29]</sup>

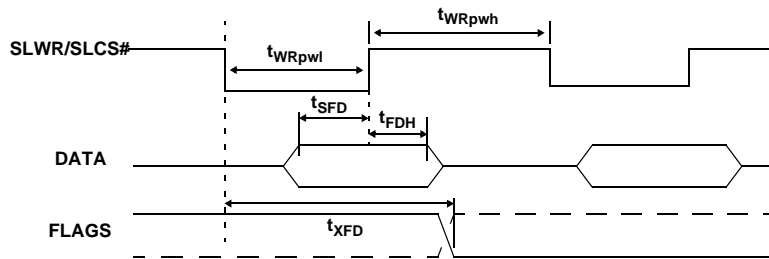

Table 34. Slave FIFO Asynchronous Write Parameters with Internally Sourced IFCLK<sup>[30]</sup>

Parameter	Description	Min	Max	Unit
$t_{WRpwl}$	SLWR pulse low	50	–	ns
$t_{WRpwh}$	SLWR pulse high	70	–	ns
$t_{SFD}$	SLWR to FIFO data setup time	10	–	ns
$t_{FDH}$	FIFO data to SLWR hold time	10	–	ns
$t_{XFD}$	SLWR to FLAGS output propagation delay	–	70	ns

Notes

- 29. Dashed lines denote signals with programmable polarity.
- 30. Slave FIFO asynchronous parameter values use internal IFCLK setting at 48 MHz.

Figure 16. Slave FIFO Asynchronous Packet End Strobe Timing Diagram

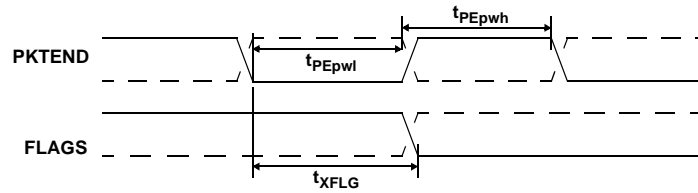

Table 35. Slave FIFO Asynchronous Packet End Strobe Parameters<sup>[31]</sup>

Parameter	Description	Min	Max	Unit
$t_{PEpwl}$	PKTEND pulse width low	50	–	ns
$t_{PEpwh}$	PKTEND pulse width high	50	–	ns
$t_{XFLG}$	PKTEND to FLAGS output propagation delay	–	110	ns

Figure 17. Slave FIFO Asynchronous Address Timing Diagram<sup>[32]</sup>

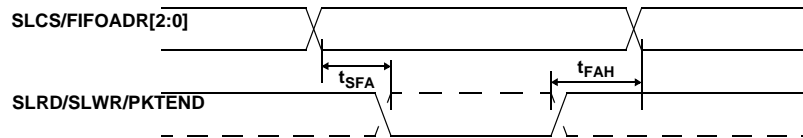

Table 36. Slave FIFO Asynchronous Address Parameters<sup>[31]</sup>

Parameter	Description	Min	Max	Unit
$t_{SFA}$	FIFOADR[2:0] to RD/WR/PKTEND setup time	10	–	ns
$t_{FAH}$	SLRD/SLWR/PKTEND to FIFOADR[2:0] hold time	20	–	ns
$t_{FAH}$	SLWR to FIFOADR[2:0] hold time	70	–	ns

**Slave FIFO Address to Flags/Data**

Following timing is applicable to synchronous and asynchronous interfaces.

Figure 18. Slave FIFO Address to Flags/Data Timing Diagram<sup>[32]</sup>

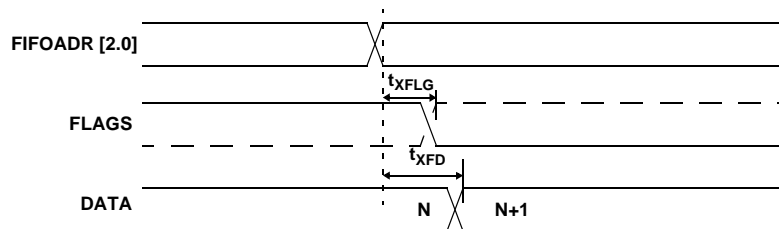

Table 37. Slave FIFO Address to Flags/Data Parameters

Parameter	Description	Min	Max	Unit
$t_{XFLG}$	FIFOADR[2:0] to FLAGS output propagation delay	–	10.7	ns
$t_{XFD}$	FIFOADR[2:0] to FIFODATA output propagation delay	–	14.3	ns

**Notes**

- 31. Slave FIFO asynchronous parameter values use internal IFCLK setting at 48 MHz.
- 32. Dashed lines denote signals with programmable polarity.

### Slave FIFO Output Enable

Following timings are applicable to synchronous and asynchronous interfaces.

**Figure 19. Slave FIFO Output Enable Timing Diagram** [33]

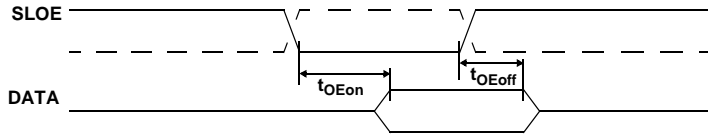
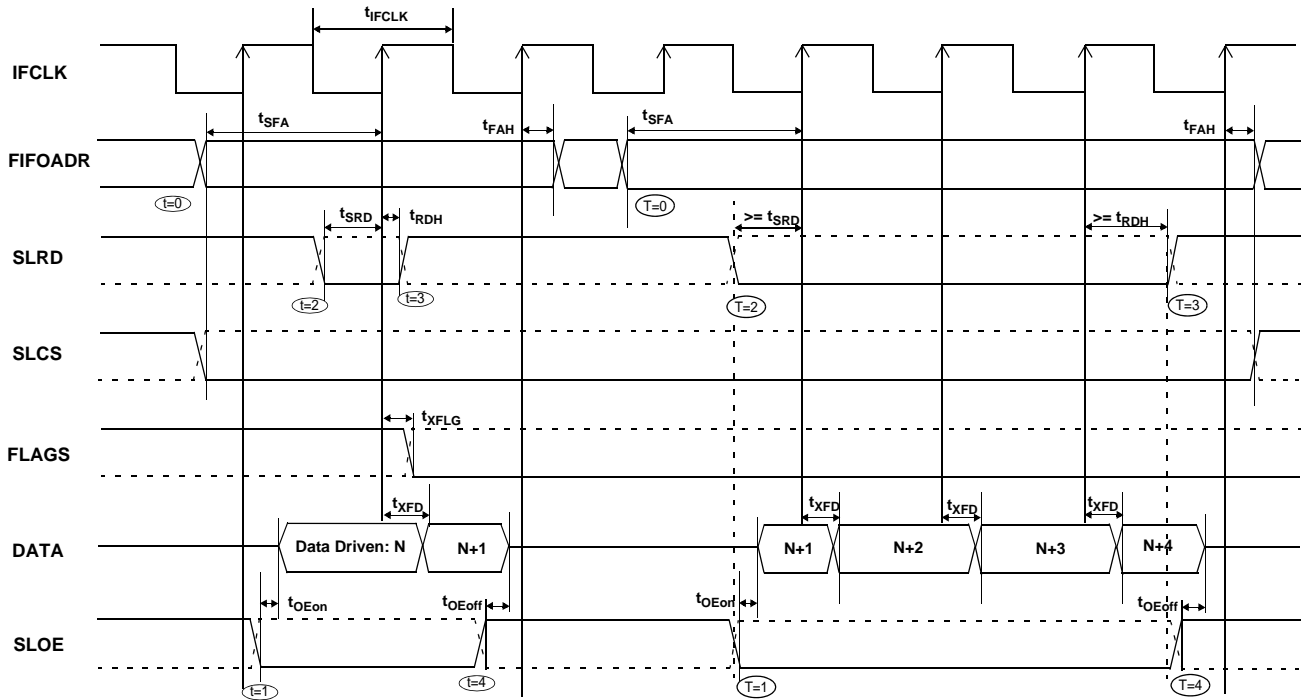

**Table 38. Slave FIFO Output Enable Parameters**

Parameter	Description	Min	Max	Unit
$t_{OEon}$	SLOE assert to FIFO Data output	–	10.5	ns
$t_{OEoff}$	SLOE deassert to FIFO Data hold	–	10.5	ns

### Sequence Diagram

**Figure 20. Slave FIFO Synchronous Read Sequence and Timing Diagram**



**Figure 21. Slave FIFO Synchronous Sequence of Events Diagram**

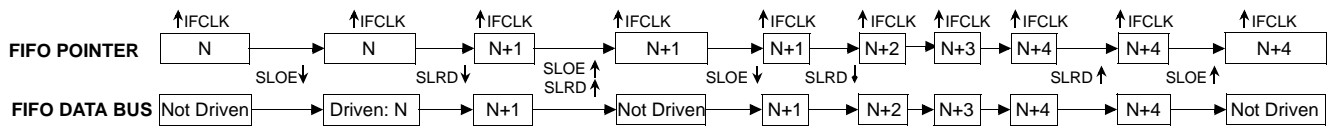

**Note**

33. Dashed lines denote signals with programmable polarity.

Figure 20 on page 33 shows the timing relationship of the SLAVE FIFO signals during a synchronous FIFO read using IFCLK as the synchronizing clock. The diagram illustrates a single read followed by a burst read.

- At  $t = 0$  the FIFO address is stable and the signal SLCS is asserted (SLCS may be tied low in some applications).

**Note**  $t_{SFA}$  has a minimum of 25 ns. This means when IFCLK is running at 48 MHz, the FIFO address setup time is more than one IFCLK cycle.

- At  $t = 1$ , SLOE is asserted. SLOE is an output enable only, whose sole function is to drive the data bus. The data that is driven on the bus is the data that the internal FIFO pointer is currently pointing to. In this example it is the first data value in the FIFO. Note that the data is pre-fetched and is driven on the bus when SLOE is asserted.

- At  $t = 2$ , SLRD is asserted. SLRD must meet the setup time of  $t_{SRD}$  (time from asserting the SLRD signal to the rising edge of the IFCLK) and maintain a minimum hold time of  $t_{RDH}$  (time from the IFCLK edge to the deassertion of the SLRD signal). If the SLCS signal is used, it must be asserted with SLRD, or

before SLRD is asserted (that is, the SLCS and SLRD signals must both be asserted to start a valid read condition).

- The FIFO pointer is updated on the rising edge of the IFCLK, while SLRD is asserted. This starts the propagation of data from the newly addressed location to the data bus. After a propagation delay of  $t_{XFD}$  (measured from the rising edge of IFCLK) the new data value is present. N is the first data value read from the FIFO. SLOE must be asserted to have data on the FIFO data bus.

The same sequence of events are shown for a burst read and are marked with the time indicators of T = 0 through 5.

- Note** For the burst mode, the SLRD and SLOE are left asserted during the entire duration of the read. In the burst read mode, when SLOE is asserted, data indexed by the FIFO pointer is on the data bus. During the first read cycle, on the rising edge of the clock the FIFO pointer is updated and increments to point to address N+1. For each subsequent rising edge of IFCLK, while the SLRD is asserted, the FIFO pointer is incremented and the next data value is placed on the data bus.

Figure 22. Slave FIFO Synchronous Write Sequence and Timing Diagram<sup>[34]</sup>

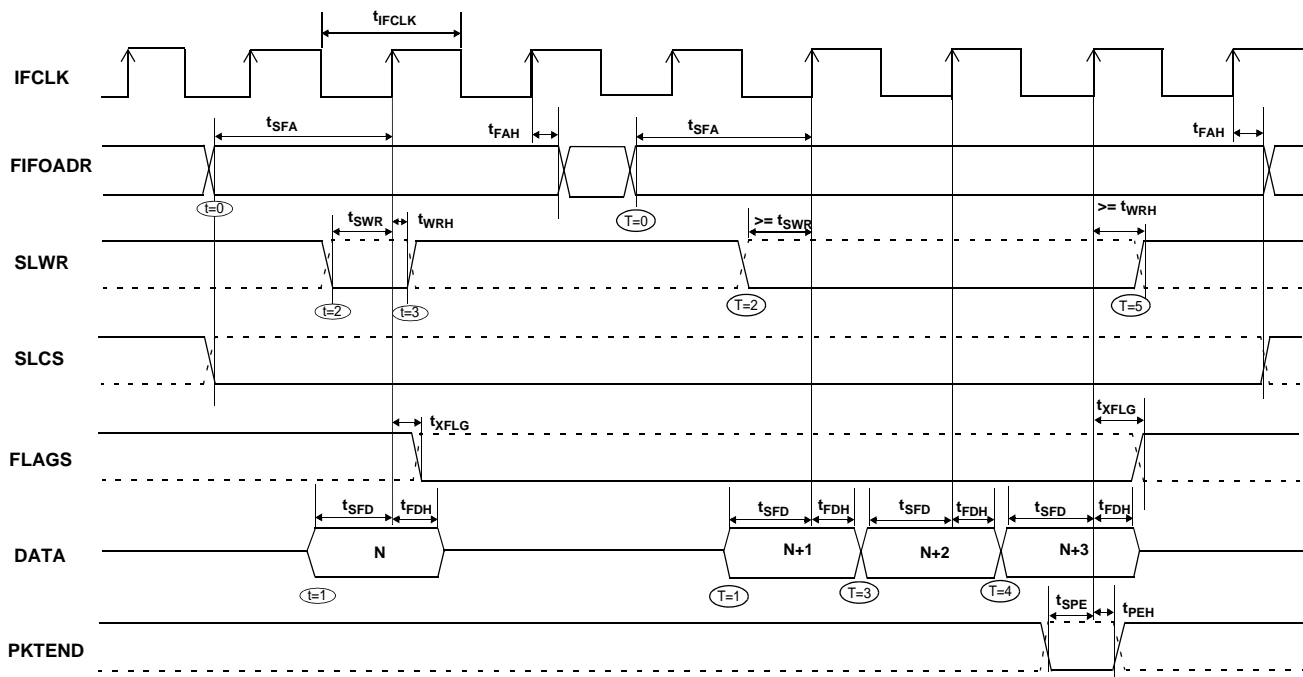

**Note**  
34. Dashed lines denote signals with programmable polarity.

Figure 22 shows the timing relationship of the SLAVE FIFO signals during a synchronous write using IFCLK as the synchronizing clock. The diagram illustrates a single write followed by burst write of 3 bytes and committing all 4 bytes as a short packet using the PKTEND pin.

- At  $t = 0$  the FIFO address is stable and the signal SLCS is asserted. (SLCS may be tied low in some applications)  
**Note**  $t_{SFA}$  has a minimum of 25 ns. This means when IFCLK is running at 48 MHz, the FIFO address setup time is more than one IFCLK cycle.
- At  $t = 1$ , the external master/peripheral must output the data value onto the data bus with a minimum set up time of  $t_{SFD}$  before the rising edge of IFCLK.
- At  $t = 2$ , SLWR is asserted. The SLWR must meet the setup time of  $t_{SWR}$  (time from asserting the SLWR signal to the rising edge of IFCLK) and maintain a minimum hold time of  $t_{WRH}$  (time from the IFCLK edge to the de-assertion of the SLWR signal). If SLCS signal is used, it must be asserted with SLWR or before SLWR is asserted. (that is, the SLCS and SLWR signals must both be asserted to start a valid write condition).
- While the SLWR is asserted, data is written to the FIFO and on the rising edge of the IFCLK, the FIFO pointer is incremented. The FIFO flag is also updated after a delay of  $t_{XFLG}$  from the rising edge of the clock.

The same sequence of events are also shown for a burst write and are marked with the time indicators of  $T = 0$  through 5.

**Note** For the burst mode, SLWR and SLCS are left asserted for the entire duration of writing all the required data values. In this burst write mode, after the SLWR is asserted, the data on the FIFO data bus is written to the FIFO on every rising edge of IFCLK. The FIFO pointer is updated on each rising edge of IFCLK. As shown in Figure 23, after the four bytes are written to the FIFO, SLWR is deasserted. The short 4-byte packet can be committed to the host by asserting the PKTEND signal.

There is no specific timing requirement that needs to be met for asserting PKTEND signal when asserting the SLWR signal. PKTEND can be asserted with the last data value or thereafter. The only consideration is the setup time  $t_{SPE}$  and the hold time  $t_{PEH}$  must be met. In the scenario of Figure 23, the number of data values committed includes the last value written to the FIFO. In this example, both the data value and the PKTEND signal are clocked on the same rising edge of IFCLK. PKTEND can be asserted in subsequent clock cycles. The FIFOADDR lines should be held constant during the PKTEND assertion.

A specific corner case condition needs attention while using the PKTEND to commit a one byte/word packet. Additional timing requirements exists when the FIFO is configured to operate in auto mode and it is desired to send two packets: a full packet (full defined as the number of bytes in the FIFO meeting the level set in AUTOINLEN register) committed automatically followed by a short one byte/word packet committed manually using the PKTEND pin. In this case, the external master must make sure to assert the PKTEND pin at least one clock cycle after the rising edge that caused the last byte/word to be clocked into the previous auto committed packet (the packet with the number of bytes equal to what is set in the AUTOINLEN register).

Figure 23. Slave FIFO Asynchronous Read Sequence and Timing Diagram

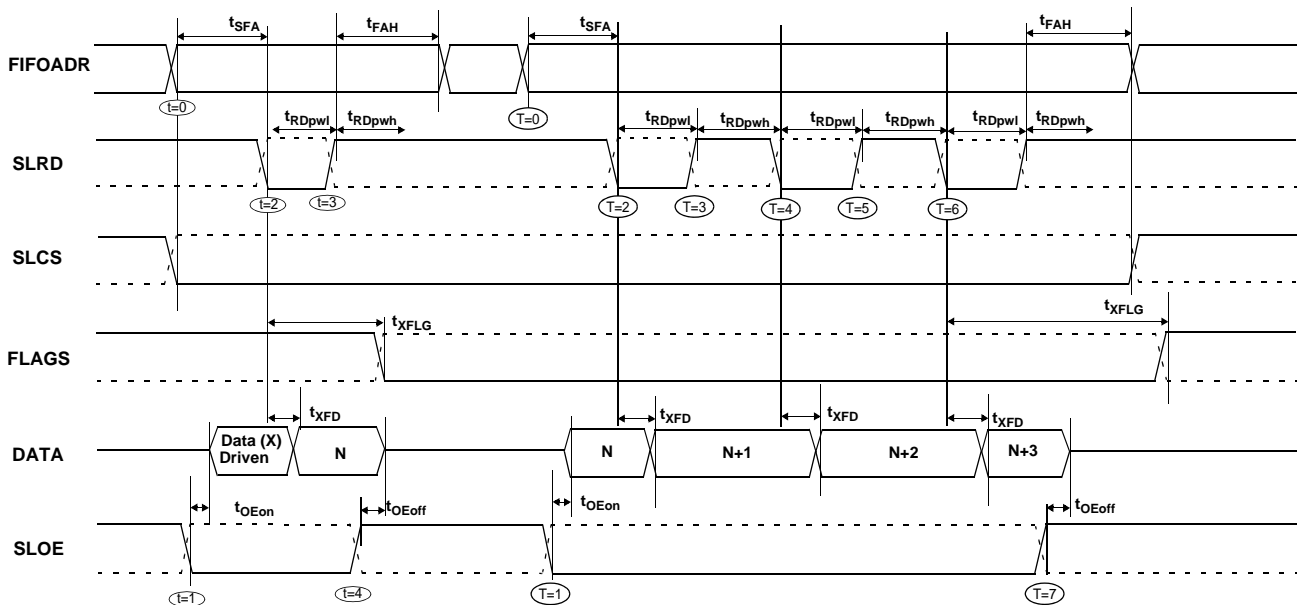

**Figure 24. Slave FIFO Asynchronous Read Sequence of Events Diagram**

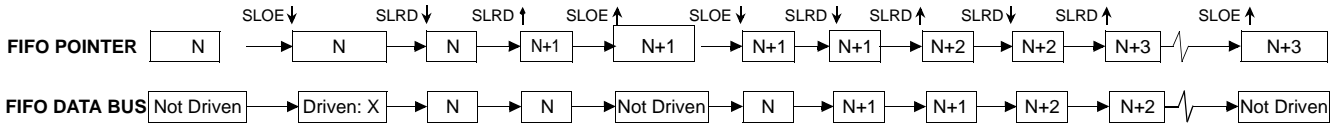

Figure 24 diagrams the timing relationship of the SLAVE FIFO signals during an asynchronous FIFO read. It shows a single read followed by a burst read.

- At  $t = 0$  the FIFO address is stable and the SLCS signal is asserted.
- At  $t = 1$ , SLOE is asserted. This results in the data bus being driven. The data that is driven on to the bus is previous data, it data that was in the FIFO from a prior read cycle.
- At  $t = 2$ , SLRD is asserted. The SLRD must meet the minimum active pulse of  $t_{RDpwl}$  and minimum de-active pulse width of  $t_{RDpwh}$ . If SLCS is used then, SLCS must be asserted with SLRD or before SLRD is asserted (that is, the SLCS and SLRD signals must both be asserted to start a valid read condition).

- The data that is driven, after asserting SLRD, is the updated data from the FIFO. This data is valid after a propagation delay of  $t_{XFD}$  from the activating edge of SLRD. In Figure 25, data N is the first valid data read from the FIFO. For data to appear on the data bus during the read cycle (that is, SLRD is asserted), SLOE MUST be in an asserted state. SLRD and SLOE can also be tied together.

The same sequence of events is also shown for a burst read marked with T = 0 through 5.

**Note** In burst read mode, during SLOE is assertion, the data bus is in a driven state and outputs the previous data. When SLRD is asserted, the data from the FIFO is driven on the data bus (SLOE must also be asserted) and then the FIFO pointer is incremented.

**Figure 25. Slave FIFO Asynchronous Write Sequence and Timing Diagram<sup>[34]</sup>**

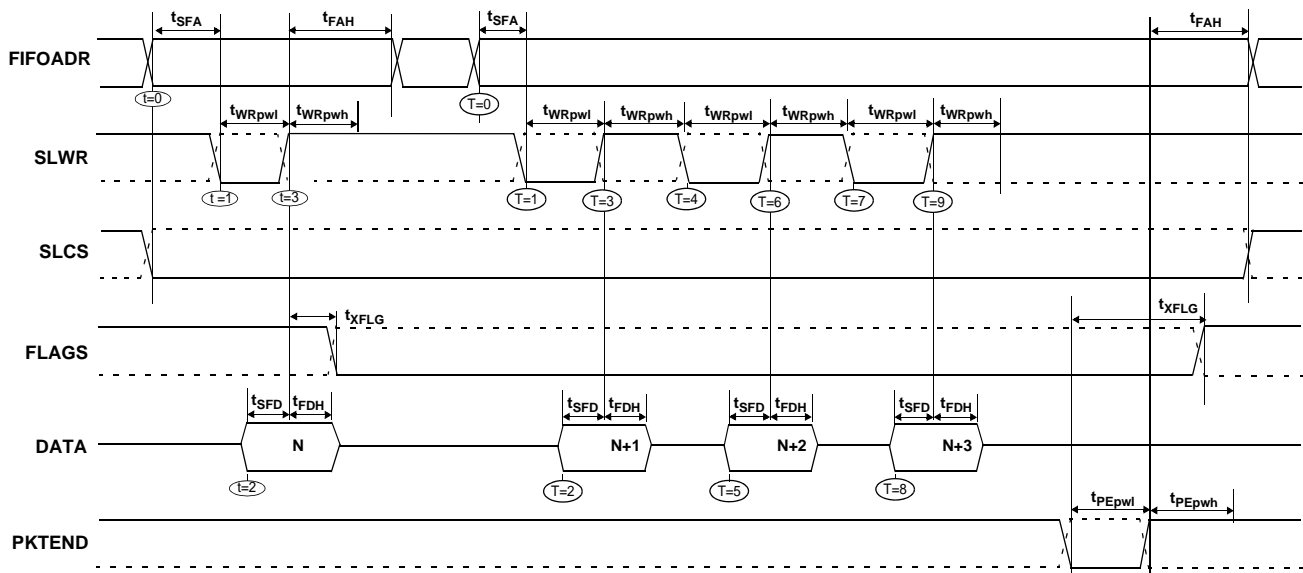

Figure 25 diagrams the timing relationship of the SLAVE FIFO write in an asynchronous mode. The diagram shows a single write followed by a burst write of 3 bytes and committing the 4-byte-short packet using PKTEND.

- At  $t = 0$  the FIFO address is applied, insuring that it meets the setup time of  $t_{SFA}$ . If SLCS is used, it must also be asserted (SLCS may be tied low in some applications).
- At  $t = 1$  SLWR is asserted. SLWR must meet the minimum active pulse of  $t_{WRpwl}$  and minimum de-active pulse width of  $t_{WRpwh}$ . If the SLCS is used, it must be asserted with SLWR or before SLWR is asserted.
- At  $t = 2$ , data must be present on the bus  $t_{SFD}$  before the deasserting edge of SLWR.
- At  $t = 3$ , deasserting SLWR causes the data to be written from the data bus to the FIFO and then increments the FIFO pointer.

The FIFO flag is also updated after  $t_{XFLG}$  from the deasserting edge of SLWR.

The same sequence of events are shown for a burst write and is indicated by the timing marks of T = 0 through 5.

**Note** In the burst write mode, when SLWR is deasserted, the data is written to the FIFO. Then, the FIFO pointer is incremented to the next byte in the FIFO. The FIFO pointer is post incremented.

In Figure 25, after the four bytes are written to the FIFO and SLWR is deasserted, the short 4-byte packet can be committed to the host using the PKTEND. The external device should be designed not to assert SLWR and the PKTEND signal at the same time. It should be designed to assert the PKTEND after SLWR is deasserted and met the minimum de-asserted pulse width. The FIFOADDR lines are to be held constant during the PKTEND assertion.

**Default Descriptor** <sup>[35]</sup>

```

//Device Descriptor
18,          //Descriptor length
1,          //Descriptor type
00,02,      //Specification Version (BCD)
00,         //Device class
00,         //Device sub-class
00,         //Device sub-sub-class
64,         //Maximum packet size
LSB(VID),MSB(VID), //Vendor ID
LSB(PID),MSB(PID), //Product ID
LSB(DID),MSB(DID), //Device ID
1,          //Manufacturer string index
2,          //Product string index
0,          //Serial number string index
1,          //Number of configurations

//DeviceQualDscr
10,         //Descriptor length
6,          //Descriptor type
0x00,0x02, //Specification Version (BCD)
00,         //Device class
00,         //Device sub-class
00,         //Device sub-sub-class
64,         //Maximum packet size
1,          //Number of configurations
0,          //Reserved

//HighSpeedConfigDscr
9,          //Descriptor length
2,          //Descriptor type
46,         //Total Length (LSB)
0,          //Total Length (MSB)
1,          //Number of interfaces
1,          //Configuration number
0,          //Configuration string
0xA0,       //Attributes (b7 - buspwr, b6 - selfpwr, b5 - rwu)
50,         //Power requirement (div 2 ma)

//Interface Descriptor
9,          //Descriptor length
4,          //Descriptor type
0,          //Zero-based index of this interface
0,          //Alternate setting
4,          //Number of end points
0xFF,       //Interface class
0x00,       //Interface sub class
0x00,       //Interface sub sub class
0,          //Interface descriptor string index

//Endpoint Descriptor
7,          //Descriptor length
5,          //Descriptor type
0x02,       //Endpoint number, and direction
2,          //Endpoint type
0x00,       //Maximum packet size (LSB)
0x02,       //Max packet size (MSB)
0x00,       //Polling interval

```

**Note**

**35. Errata:** The internal flag selfpwr is set to False at initialization and is not updated during program execution regardless of whether the device descriptors are programmed for self power. Therefore, the device always returns false for selfpower and always reports as bus powered. For more information, refer ["Errata"](#) on page 44.

```
//Endpoint Descriptor
7,          //Descriptor length
5,          //Descriptor type
0x04,       //Endpoint number, and direction
2,          //Endpoint type
0x00,       //Maximum packet size (LSB)
0x02,       //Max packet size (MSB)
0x00,       //Polling interval

//Endpoint Descriptor
7,          //Descriptor length
5,          //Descriptor type
0x86,       //Endpoint number, and direction
2,          //Endpoint type
0x00,       //Maximum packet size (LSB)
0x02,       //Max packet size (MSB)
0x00,       //Polling interval

//Endpoint Descriptor
7,          //Descriptor length
5,          //Descriptor type
0x88,       //Endpoint number, and direction
2,          //Endpoint type
0x00,       //Maximum packet size (LSB)
0x02,       //Max packet size (MSB)
0x00,       //Polling interval

//FullSpeedConfigDscr
9,          //Descriptor length
2,          //Descriptor type
46,         //Total Length (LSB)
0,          //Total Length (MSB)
1,          //Number of interfaces
1,          //Configuration number
0,          //Configuration string
0xA0,       //Attributes (b7 - buspwr, b6 - selfpwr, b5 - rwu)
50,         //Power requirement (div 2 ma)

//Interface Descriptor
9,          //Descriptor length
4,          //Descriptor type
0,          //Zero-based index of this interface
0,          //Alternate setting
4,          //Number of end points
0xFF,       //Interface class
0x00,       //Interface sub class
0x00,       //Interface sub sub class
0,          //Interface descriptor string index

//Endpoint Descriptor
7,          //Descriptor length
5,          //Descriptor type
0x02,       //Endpoint number, and direction
2,          //Endpoint type
0x40,       //Maximum packet size (LSB)
0x00,       //Max packet size (MSB)
0x00,       //Polling interval
```

```
//Endpoint Descriptor
7,          //Descriptor length
5,          //Descriptor type
0x04,      //Endpoint number, and direction
2,          //Endpoint type
0x40,      //Maximum packet size (LSB)
0x00,      //Max packet size (MSB)
0x00,      //Polling interval

//Endpoint Descriptor
7,          //Descriptor length
5,          //Descriptor type
0x86,      //Endpoint number, and direction
2,          //Endpoint type
0x40,      //Maximum packet size (LSB)
0x00,      //Max packet size (MSB)
0x00,      //Polling interval

//Endpoint Descriptor
7,          //Descriptor length
5,          //Descriptor type
0x88,      //Endpoint number, and direction
2,          //Endpoint type
0x40,      //Maximum packet size (LSB)
0x00,      //Max packet size (MSB)
0x00,      //Polling interval

//StringDscr

//StringDscr0
4,          //String descriptor length
3,          //String Descriptor
0x09,0x04, //US LANGID Code

//StringDscr1
16,         //String descriptor length
3,          //String Descriptor
'C',00,
'y',00,
'p',00,
'r',00,
'e',00,
's',00,
's',00,

//StringDscr2
20,         //String descriptor length
3,          //String Descriptor
'C',00,
'Y',00,
'7',00,
'C',00,
'6',00,
'8',00,
'0',00,
'0',00,
'1',00,
```

### General PCB Layout Guidelines<sup>[36]</sup>

Follow these recommendations to ensure high-performance operation.

- Use at least four-layer impedance controlled boards to maintain signal quality.
- Specify impedance targets (ask your board vendor what they can achieve).
- Maintain trace widths and trace spacing to control impedance.
- Minimize stubs to minimize reflected signals.
- Connect the USB connector shell and signal ground near the USB connector.
- Use bypass/flyback caps on VBus, near connector.
- Keep DPLUS and DMINUS trace lengths to within 2 mm of each other in length; preferred length is 20 mm to 30 mm.
- Maintain a solid ground plane under the DPLUS and DMINUS traces. Do not allow the plane to be split under these traces.
- Do not place vias on the DPLUS or DMINUS trace routing.
- Isolate the DPLUS and DMINUS traces from all other signal traces by no less than 10 mm.

### Quad Flat Package No Leads (QFN) Package Design Notes

Electrical contact of the part to the Printed Circuit Board (PCB) is made by soldering the leads on the bottom surface of the package to the PCB. Hence, special attention is required to the heat transfer area below the package to provide a good thermal bond to the circuit board. A Copper (Cu) fill is to be designed into the PCB as a thermal pad under the package. Heat is transferred from the SX2 through the device's metal paddle on the bottom side of the package. Heat from here, is conducted to the PCB at the thermal pad. It is then conducted from the thermal pad to the PCB inner ground plane by a 5 x 5 array of via. A via is a plated through hole in the PCB with a finished diameter of 13 mil. The QFN's metal die paddle must be soldered to the PCB's thermal pad. Solder mask is placed on the board top side over each via to resist solder flow into the via. The mask on the top side also minimizes outgassing during the solder reflow process.

For further information on this package design refer to "Application Notes for Surface Mount Assembly of Amkor's MicroLead-Frame® (MLF®) Packages at the following website: [http://www.amkor.com/products/notes\\_papers/MLFAppNote.pdf](http://www.amkor.com/products/notes_papers/MLFAppNote.pdf). The application note provides detailed information on board mounting guidelines, soldering flow, and rework process.

Figure 26 on page 40 displays a cross-sectional area underneath the package. The cross section is of only one via. The solder paste template needs to be designed to allow at least 50% solder coverage. The thickness of the solder paste template should be 5 mil. It is recommended that "No Clean" type 3 solder paste is used for mounting the part. Nitrogen purge is recommended during reflow.

Figure 27 is a plot of the solder mask pattern and Figure 28 displays an X-Ray image of the assembly (darker areas indicate solder).

Figure 26. Cross section of the Area Underneath the QFN Package

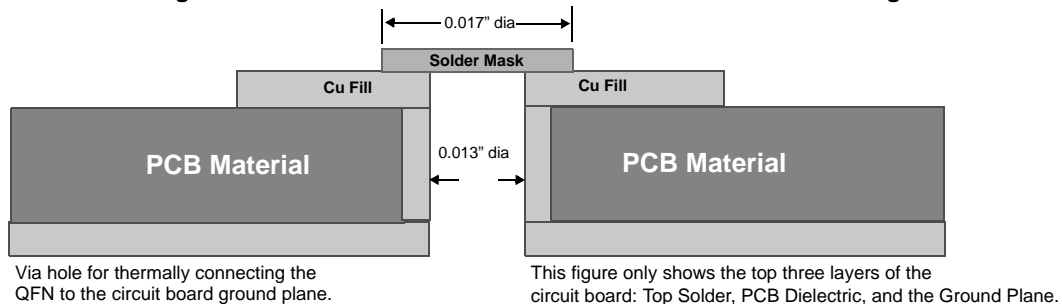

Figure 27. Plot of the Solder Mask (White Area)

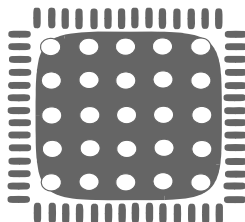
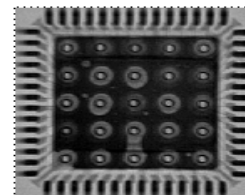

Figure 28. X-Ray Image of the Assembly



**Note**

36. Source for recommendations: *High Speed USB Platform Design Guidelines*, [http://www.usb.org/developers/data/hs\\_usb\\_pdg\\_r1\\_0.pdf](http://www.usb.org/developers/data/hs_usb_pdg_r1_0.pdf).

### Ordering Information

Ordering Code	Package Type
CY7C68001-56PVXC	56 SSOP, Pb-free
CY7C68001-56LTXC	56 QFN, Pb-free

### Ordering Code Definition

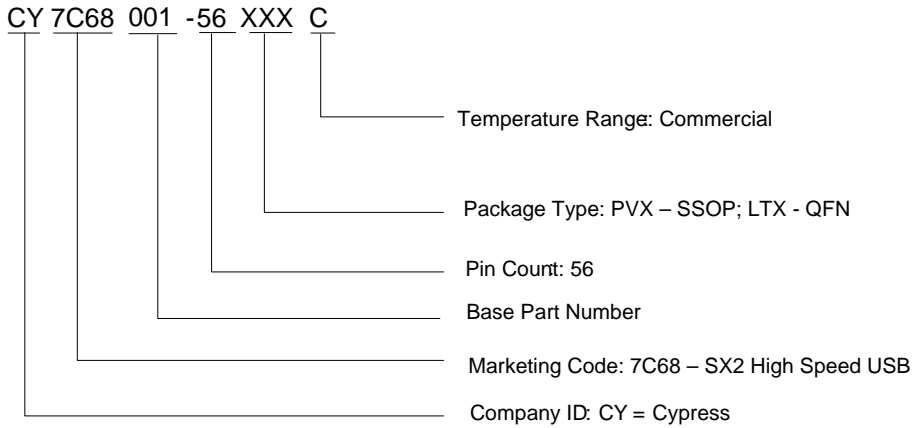

### Package Diagrams

Figure 29. 56-pin SSOP (300 Mils) O563 Package Outline, 51-85062

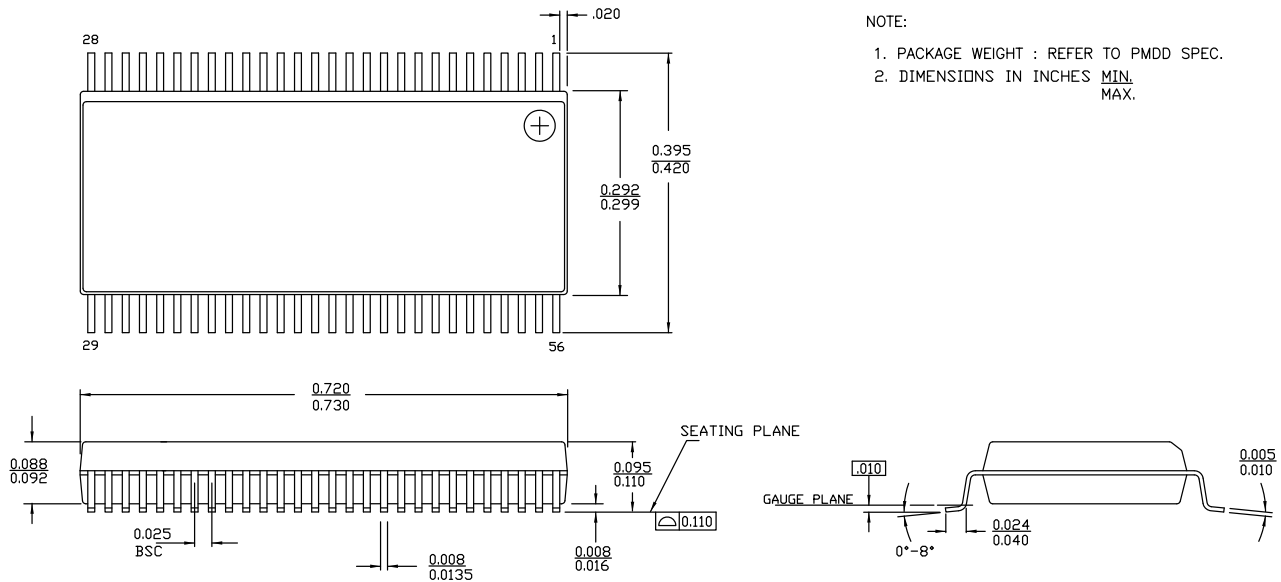

51-85062 \*F

Figure 30. 56-pin QFN (8 x 8 x 1.00 mm) LT56 6.1 x 6.1 E-Pad (Sawn) Package Outline, 51-85187

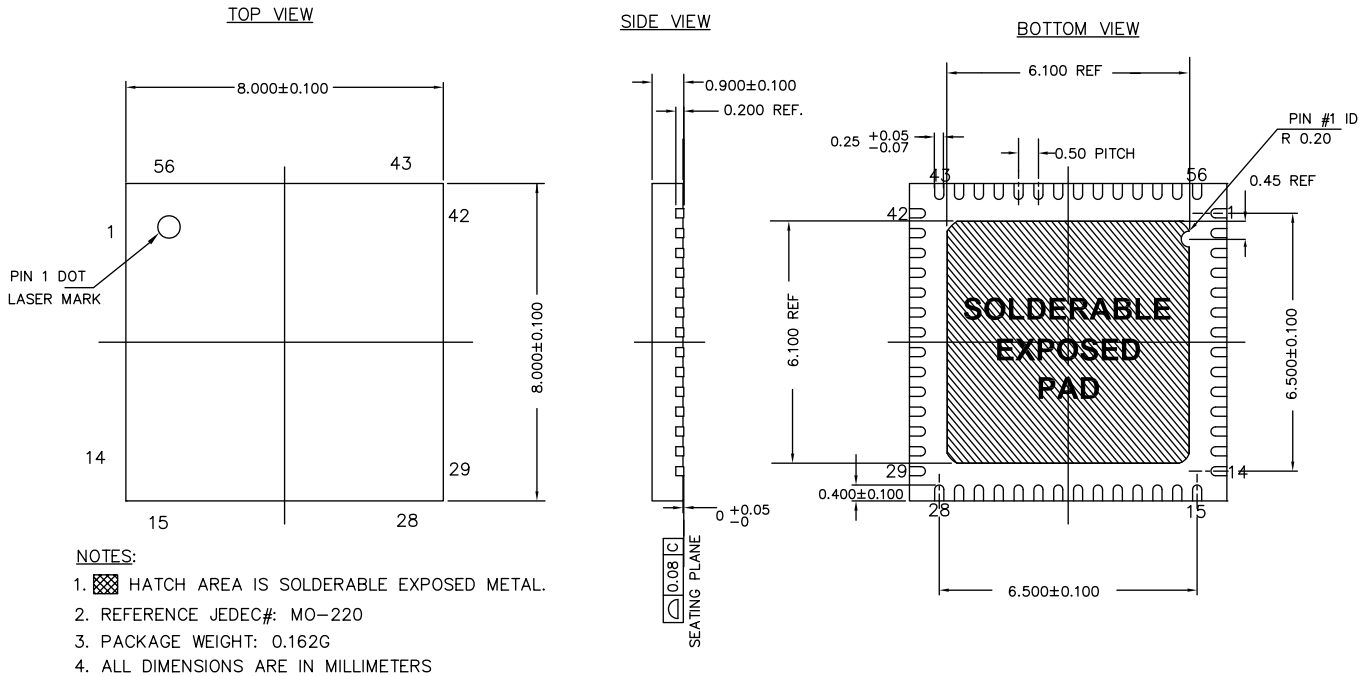

51-85187 \*G

## Acronyms

Table 39. Acronyms

Acronym	Description
ASIC	Application Specific Integrated Circuit
ATA	Advanced Technology Attachment
CPU	Central Processing Unit
DSP	Digital Signal Processor
ECC	Error Correcting Codes
GPIF	General Programmable Interface
GPIO	General Purpose I/O
IC	Integrated Circuit
ICE	In-Circuit Emulator
I/O	Input/Output
LSb	Least-Significant Bit
LVD	Low Voltage Detect
MSb	Most-Significant Bit
PLL	Phase Locked Loop
PCB	Printed Circuit Board
PNA	Phoneline Networking Alliance
POR	Power On Reset
PSoC <sup>®</sup>	Programmable System-on-Chip
SCL	Serial Clock
SDA	Serial Data Line
RAM	Random Access Memory
USB	Universal Serial Bus
USB-IF	USB Implementor's Forum
QFN	Quad Flat No-lead
SSOP	Shrink Small Outline Package

## Document Conventions

### Units of Measure

Table 40. Units of Measure

Symbol	Unit of Measure
°C	degree Celsius
mA	milliampere
ms	millisecond
ns	nanosecond
pF	picofarad
V	volt

## Errata

This section describes the errata for the EZ-USB SX2/CY7C68001. Details include errata trigger conditions, available workarounds, and silicon revision applicability.

Contact your local Cypress Sales Representative if you have further questions.

### Part Numbers Affected

Part Number	Device Characteristics
CY7C68001	All Packages

### EZ-USB SX2 Qualification Status

Product status: In production - Qual report 012406

### EZ-USB SX2 Errata Summary

The following table defines the errata applicability to available EZ-USB SX2 family devices. An “X” indicates that the errata pertains to the selected device.

**Note:** Errata titles are hyperlinked. Click on table entry to jump to description.

Items	Part Number	Rev E	Fix Status
<a href="#">1. Reset Timing/Unknown Device</a>	CY7C68001	X	Use workaround
<a href="#">2. EP4, 6, 8 Packet Length Register, High Byte, Read back Error</a>	CY7C68001	X	Use workaround
<a href="#">3. Get Status for a Device Always Reports Bus Powered</a>	CY7C68001	X	Use workaround
<a href="#">4. SX2's Response to SET_INTERFACE Request</a>	CY7C68001	X	Use workaround

#### 1. Reset Timing/Unknown Device

##### ■ Problem Definition

If during the power-on sequence, the SX2 is held in Reset for a long period, it may be recognized by the Host Controller as an Unknown Device and dropped off the USB.

##### ■ Parameters Affected

Reset timing

##### ■ Trigger Condition(S)

Reset sequence

##### ■ Scope of Impact

In normal operation, the SX2 disconnects itself from USB after Reset, awaiting the command from the external master to enumerate. If, however, the SX2 is held in Reset after power-on it is stopped from performing the actual disconnect. If left connected by maintaining a reset condition too long, 5 to 10 seconds, dependant on Host conditions, the Host will identify the SX2 as an Unknown Device. Note that according to USB 2.0 specification, all devices must be capable of enumerating within 100 ms. Device may appear as an Unknown Device and be dropped off of USB.

##### ■ Workaround

Retain standard SX2 power-on Reset timing of 10 ms, either through an RC circuit or via the external master.

##### ■ Fix Status

N/A

## 2. EP4, 6, 8 Packet Length Register, High Byte, Read back Error

### ■ Problem Definition

When reading from the SX2 EPxPKTLENH register for endpoints 4, 6, and 8, the lower nibble is returned with an incorrect value.

### ■ Parameters Affected

N/A

### ■ Trigger Condition(S)

EPxPKTLENH register reads

### ■ Scope of Impact

The lower nibbles of 0x0C (EP4PKTLENH), 0x0E (EP6PKTLENH), and 0x10 (EP8PKTLENH) are incorrect. Note that these registers are control registers. Read back errors will not negatively affect SX2 operations.

### ■ Workaround

If the external master needs to retain the values as programmed in 0x0C (EP4PKTLENH), 0x0E (EP6PKTLENH), and 0x10 (EP8PKTLENH), it must maintain them in local memory.

### ■ Fix Status

N/A

## 3. Get Status for a Device Always Reports Bus Powered

### ■ Problem Definition

When returning the power status, the SX2 always returns bus powered condition.

### ■ Parameters Affected

The self power bit is always false

### ■ Trigger Condition(S)

Host sends a Get Status request for the device type

### ■ Scope of Impact

The internal flag selfpwr is set to False at initialization and is not updated during program execution regardless of whether the device descriptors are programmed for self power. Therefore, the device always returns false for selfpower and always reports as bus powered.

### ■ Workaround

To pass the USBV certification test, the device descriptors should be programmed for bus powered and claim a small amount of bus current (for example, 2 mA).

### ■ Fix Status

N/A

#### 4. SX2's Response to SET\_INTERFACE Request

##### ■ Problem Definition

SET\_INTERFACE is a standard EP0 request, which needs to be handled by the external master to perform all the changes in Endpoint configuration. So SX2 notifies the external master with the SETUP interrupt.

In case of other non-standard EP0 requests with no data stage, external master is notified with the SETUP interrupt, and the external master can accept the packet and complete the handshake phase by writing zero to the byte count register. SX2 waits for the external master to write zero into byte count register before acknowledging it.

But unlike the case of non-standard EP0 requests with no data phase, SX2 doesn't wait for the external master to write zero into byte count register in the case of SET\_INTERFACE. Instead SX2 acknowledges the transfer by itself.

##### ■ Parameters Affected

N/A

##### ■ Trigger Condition(S)

USB Host sends SET\_INTERFACE request

##### ■ Scope of Impact

If the SET\_INTERFACE request is followed by another EP0 request, unless the external master's firmware is fast enough to read the SETUP packet of SET\_INTERFACE before the USB host writes into register, 0x32, with the SETUP PACKET of the next command, the commands might get mixed up.

##### ■ Workaround

Either by making the external master's firmware fast enough to read the first setup packet before the arrival of the next setup packet, or having the USB host issue the second command after the first command has been attended to, can help the external master to read both the setup packets, without mixing them up.

##### ■ Fix Status

There is no silicon fix planned for this currently, please use above workaround

## Document History Page

Description Title: CY7C68001, EZ-USB SX2™ High-Speed USB Interface Device Document Number: 38-08013				
Rev.	ECN No.	Origin of Change	Submission Date	Description of Change
**	111807	BHA	06/07/02	New data sheet.
*A	123155	BHA	02/07/03	Minor clean-up and clarification Removed references to IRQ Register and replaced them with references to Interrupt Status Byte Modified pin-out description for XTALIN and XTALOUT Added CS# timing to <a href="#">Figure 13</a> , <a href="#">Figure 15</a> , and <a href="#">Figure 17</a> Changed Command Protocol example to IFCONFIG (0x01) Edited PCB Layout Recommendations Added AR#10691 Added USB high speed logo
*B	126324	MON	07/02/03	Default state of registers specified in section where the register bits are defined Reorganized timing diagram presentation: First all timing related to synchronous interface, followed by timing related to asynchronous interface, followed by timing diagrams common to both interfaces Provided further information in section regarding boot methods Provided timing diagram that encapsulates ALL relevant signals for a synchronous and asynchronous slave read and write interface Added section on (QFN) Package Design Notes FIFOADR[2:0] Hold Time ( $t_{FAH}$ ) for Asynchronous FIFO Interface has been updated as follows: SLRD/PKTEND to FIFOADR[2:0] Hold Time: 20 ns; SLWR to FIFOADR[2:0] Hold Time:70 ns (recommended) Added information on the polarity of the programmable flag Fixed the Command Synchronous Write Timing Diagram Fixed the Command Asynchronous Write Timing Diagram Added information on the delay required when endpoint configuration registers are changed after SX2 has already enumerated
*C	129463	MON	10/07/03	Added Test ID for the USB Compliance Test Added information on the fact that the SX2 does not automatically respond to Set/Clear Feature Endpoint (Stall) request, external master intervention required Added information on accessing undocumented register which are not indexed (for resetting data toggle) Added information on requirement of clock stability before releasing reset Added information on configuration of PF register for full speed Updated confirmed timing on FIFOADR[2:0] Hold Time ( $t_{FAH}$ ) for Asynchronous FIFO Interface has been updated Corrected the default bit settings of EPxxFLAGS register Added information on how to change SLWR/SLRD/SLOE polarities Added further information on buffering interrupt on initiation of a command read request Change the default state of the FNADDR to 0x00 Added further labels on the sequence diagram for synchronous and asynchronous read and write in single and burst mode Added information on the maximum delay allowed between each descriptor byte write once a command write request to register 0x30 has been initiated by the external master

**Document History Page** (continued)

Description Title: CY7C68001, EZ-USB SX2™ High-Speed USB Interface Device Document Number: 38-08013				
Rev.	ECN No.	Origin of Change	Submission Date	Description of Change
*D	130447	KKU	12/17/03	<p>Replaced package diagram in <a href="#">Figure 30</a> spec number 51-85144 with clear image</p> <p>Fixed last history entry for rev *C</p> <p>Change reference in section 2.7.2.4 from XXXXXXXX to 7.3</p> <p>Removed the word "compatible" in section 3.3</p> <p>Change the text in section 5.0, last paragraph from 0xE6FB to 0xE683</p> <p>Changed label "Reset" to "Default" in sections 5.1 and 7.2 through 7.14</p> <p>Reformatted Figure 4</p> <p>Added entries 3A, 3B, 3C, 0xE609, and 0xE683 to <a href="#">Figure 13</a></p> <p>Change access on hex values 07 and 09 from bbbbbbbb to bbbbrbr</p> <p>Removed <math>t_{XFD}</math> from <a href="#">Figure 13</a> and <a href="#">Figure 14</a> and tables 11-1,2, and 5</p> <p>Corrected timing diagrams, figures 11-1,11-2, 11-6</p> <p>Changed <a href="#">Figure 20</a> through <a href="#">Figure 25</a> for clarity, text which followed had reference to t3 which should be t2, added reference of t3 for deasserting SLWR and reworded section 11.6</p> <p>Updated <math>I_{CC}</math> typical and maximum values</p>
*E	243316	KKU	See ECN	<p>Reformatted data sheet to latest format</p> <p>Added Lead-free parts numbers</p> <p>Updated default value for address 0x07 and 0x09</p> <p>Added Footnote 3.</p> <p>Removed requirement of less then 360 nsec period between nibble writes in command</p> <p>Changed PKTEND to FLAGS output propagation delay in table 11-16 from a max value of 70 ns to 110 ns</p>
*F	329238	KEV	See ECN	<p>Provided additional timing restrictions and requirement regarding the use of PKTEND pin to commit a short one byte/word packet subsequent to committing a packet automatically (when in auto mode)</p> <p>Miscellaneous grammar corrections.</p> <p>Added 3.4.3 section header.</p> <p>Fixed command sequence step 3 to say register value instead of High Byte of Register Address (upper and lower nibble in two places).</p> <p>Removed statement that programmable flag polarity is set to active low and cannot be altered. Programmable flag relies on DECIS bit settings.</p> <p>Updated Amkor application note URL.</p> <p>Changed <math>T_{XINT}</math> in Figure 11-3 to be from deassertion edge of SLRD.</p> <p>Changed <math>T_{RDY}</math> in Figure 11-4 to be from deassertion edge of SLWR.</p> <p>Changed FLAGS Interrupt from empty to not-empty to both empty to not-empty and from not-empty to empty conditions for triggering this interrupt.</p>
*G	392570	KEV	See ECN	<p>Modified <a href="#">Figure 2</a> to fit across columns. It was getting cropped in half.</p> <p>Changed corporate address to 198 Champion Court.</p>
*H	411515	BHA	See ECN	<p>Added information in section <a href="#">USB Signaling Speed</a> on page 3 on Full Speed only enumeration.</p>
*I	2665531	DPT / PYRS	02/26/2009	<p>Added package diagram (51-85187) and updated Ordering Information table.</p> <p>Updated template</p>
*J	2733374	ANTG / AESA	07/08/2009	<p>Updated cross-references on pages 2 and 3</p> <p>Updated section numbers</p>
*K	2896582	ODC	03/19/10	<p>Removed obsolete parts from the ordering information table</p> <p>Updated package diagrams</p>
*L	2937795	ODC	05/26/2010	<p>Modified default value of EP4PFH register.</p> <p>Formatted table footnotes.</p> <p>Added table of contents and Acronyms table.</p>

Document History Page (continued)

Description Title: CY7C68001, EZ-USB SX2™ High-Speed USB Interface Device Document Number: 38-08013				
Rev.	ECN No.	Origin of Change	Submission Date	Description of Change
*M	3076145	ODC	11/17/2010	Added <a href="#">Ordering Code Definition</a> under <a href="#">Ordering Information</a> . Updated to new template.
*N	3565907	GAYA	03/29/2012	Updated <a href="#">Package Diagrams</a> : spec 51-85062 – Changed revision from *D to *E. spec 51-85144 – Changed revision from *H to *I. spec 51-85187 – Changed revision from *E to *F. Added <a href="#">Units of Measure</a> .
*O	3604086	GAYA	05/07/2012	Updated <a href="#">Package Diagrams</a> : Removed spec 51-85144 *I.
*P	3999456	GAYA	07/22/2013	Added Errata footnotes (Note 3, 8, 12, 13, 14, 15, 17, 35).  Updated <a href="#">Functional Overview</a> : Updated <a href="#">Resets and Wakeup</a> : Updated <a href="#">Reset [3]</a> : Added Note 3 and referred the same note in the heading.  Updated <a href="#">Endpoint 0 [8]</a> : Added Note 8 and referred the same note in the heading.  Updated <a href="#">Register Summary</a> : Added Note 12 and referred the same note in “EP2PKTLENH”. Added Note 13 and referred the same note in “EP4PKTLENH”. Added Note 14 and referred the same note in “EP6PKTLENH”. Added Note 15 and referred the same note in “EP8PKTLENH”. Updated <a href="#">EPxPKTLENH/L Registers 0x0A–0x11 [17]</a> Added Note 17 and referred the same note in the heading.  Updated <a href="#">Default Descriptor [35]</a> : Added Note 35 and referred the same note in the heading.  Updated <a href="#">Package Diagrams</a> : spec 51-85062 – Changed revision from *E to *F.  Added <a href="#">Errata</a> .  Updated to new template.
*Q	4197008	GAYA	11/20/2013	No technical updates. Completing Sunset Review.
*R	5545226	GAYA	12/07/2016	Updated <a href="#">Package Diagrams</a> : spec 51-85187 – Changed revision from *F to *G. Updated to new template. Completing Sunset Review.
*S	5755342	HARA	05/30/2017	Updated logo and copyright.

## Sales, Solutions, and Legal Information

### Worldwide Sales and Design Support

Cypress maintains a worldwide network of offices, solution centers, manufacturer's representatives, and distributors. To find the office closest to you, visit us at [Cypress Locations](#).

#### Products

ARM® Cortex® Microcontrollers	<a href="http://cypress.com/arm">cypress.com/arm</a>
Automotive	<a href="http://cypress.com/automotive">cypress.com/automotive</a>
Clocks & Buffers	<a href="http://cypress.com/clocks">cypress.com/clocks</a>
Interface	<a href="http://cypress.com/interface">cypress.com/interface</a>
Internet of Things	<a href="http://cypress.com/iot">cypress.com/iot</a>
Lighting & Power Control	<a href="http://cypress.com/powerpsoc">cypress.com/powerpsoc</a>
Memory	<a href="http://cypress.com/memory">cypress.com/memory</a>
PSoC	<a href="http://cypress.com/psoc">cypress.com/psoc</a>
Touch Sensing	<a href="http://cypress.com/touch">cypress.com/touch</a>
USB Controllers	<a href="http://cypress.com/usb">cypress.com/usb</a>
Wireless/RF	<a href="http://cypress.com/wireless">cypress.com/wireless</a>

#### PSoC® Solutions

[PSoC 1](#) | [PSoC 3](#) | [PSoC 4](#) | [PSoC 5LP](#)

#### Cypress Developer Community

[Forums](#) | [Projects](#) | [Video](#) | [Blogs](#) | [Training](#) | [Components](#)

#### Technical Support

[cypress.com/support](http://cypress.com/support)

© Cypress Semiconductor Corporation, 2002–2017. This document is the property of Cypress Semiconductor Corporation and its subsidiaries, including Spansion LLC ("Cypress"). This document, including any software or firmware included or referenced in this document ("Software"), is owned by Cypress under the intellectual property laws and treaties of the United States and other countries worldwide. Cypress reserves all rights under such laws and treaties and does not, except as specifically stated in this paragraph, grant any license under its patents, copyrights, trademarks, or other intellectual property rights. If the Software is not accompanied by a license agreement and you do not otherwise have a written agreement with Cypress governing the use of the Software, then Cypress hereby grants you a personal, non-exclusive, nontransferable license (without the right to sublicense) (1) under its copyright rights in the Software (a) for Software provided in source code form, to modify and reproduce the Software solely for use with Cypress hardware products, only internally within your organization, and (b) to distribute the Software in binary code form externally to end users (either directly or indirectly through resellers and distributors), solely for use on Cypress hardware product units, and (2) under those claims of Cypress's patents that are infringed by the Software (as provided by Cypress, unmodified) to make, use, distribute, and import the Software solely for use with Cypress hardware products. Any other use, reproduction, modification, translation, or compilation of the Software is prohibited.

TO THE EXTENT PERMITTED BY APPLICABLE LAW, CYPRESS MAKES NO WARRANTY OF ANY KIND, EXPRESS OR IMPLIED, WITH REGARD TO THIS DOCUMENT OR ANY SOFTWARE OR ACCOMPANYING HARDWARE, INCLUDING, BUT NOT LIMITED TO, THE IMPLIED WARRANTIES OF MERCHANTABILITY AND FITNESS FOR A PARTICULAR PURPOSE. To the extent permitted by applicable law, Cypress reserves the right to make changes to this document without further notice. Cypress does not assume any liability arising out of the application or use of any product or circuit described in this document. Any information provided in this document, including any sample design information or programming code, is provided only for reference purposes. It is the responsibility of the user of this document to properly design, program, and test the functionality and safety of any application made of this information and any resulting product. Cypress products are not designed, intended, or authorized for use as critical components in systems designed or intended for the operation of weapons, weapons systems, nuclear installations, life-support devices or systems, other medical devices or systems (including resuscitation equipment and surgical implants), pollution control or hazardous substances management, or other uses where the failure of the device or system could cause personal injury, death, or property damage ("Unintended Uses"). A critical component is any component of a device or system whose failure to perform can be reasonably expected to cause the failure of the device or system, or to affect its safety or effectiveness. Cypress is not liable, in whole or in part, and you shall and hereby do release Cypress from any claim, damage, or other liability arising from or related to all Unintended Uses of Cypress products. You shall indemnify and hold Cypress harmless from and against all claims, costs, damages, and other liabilities, including claims for personal injury or death, arising from or related to any Unintended Uses of Cypress products.

Cypress, the Cypress logo, Spansion, the Spansion logo, and combinations thereof, WICED, PSoC, CapSense, EZ-USB, F-RAM, and Traveo are trademarks or registered trademarks of Cypress in the United States and other countries. For a more complete list of Cypress trademarks, visit [cypress.com](http://cypress.com). Other names and brands may be claimed as property of their respective owners.

## Looking for pricing, stock, or lifecycle information?

Click below to explore more details on WIN SOURCE:

 [View CY7C68001-56PVXCT on WIN SOURCE](#)

 [Cypress Semiconductor Corp](#) Information

## Optimize Your Supply Chain with WIN SOURCE Solutions

-  Global Sourcing Solution
-  Obsolete Management
-  Cost Control Management
-  Shortage Management
-  Alternative Solution
-  Excess Inventory Management