

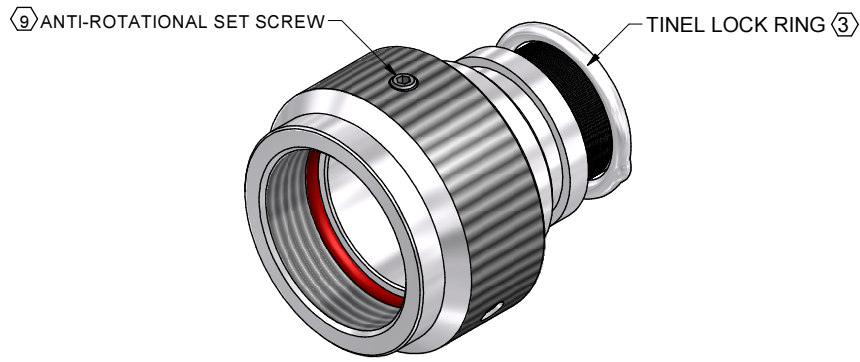

**THE DATASHEET OF
TXR18AB00D2008AI**





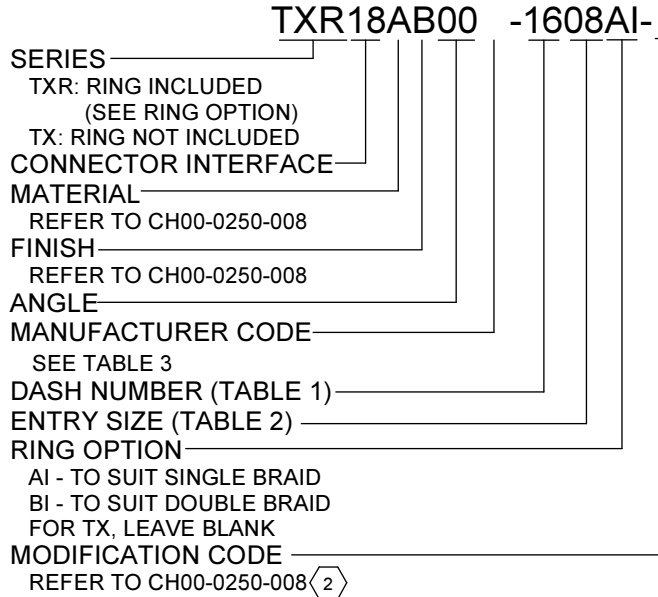

CODE 18 - TINEL-LOCK BACKSHELL



NOTES:

1. THIS PRODUCT IS DESIGNED TO TERMINATE A BRAIDED CABLE SHIELD AND A HEAT SHRINKABLE LIPPED BOOT TO A CONNECTOR.
- (2) FOR ADDITIONAL DIMENSIONS, ORDERING INFORMATION AND MODIFICATIONS, SEE CH00-0250-008.
- (3) SEE DRAWING TR FOR DETAIL ON TINEL-LOCK RING, RINGS ARE DESIGNED TO BE HEATED ELECTRICALLY, ALL RINGS ARE MARKED WITH THERMOCHROMIC PAINT WHICH CHANGES COLOUR WHEN INSTALLATION TEMPERATURE IS REACHED.
4. BACKSHELL TO BE PERMANENTLY MARKED/BAGGED AND LABELLED WITH CODE IDENTIFICATION NUMBER AND PART NUMBER LESS RING DESIGNATOR. (e.g. 06090-TXR18AB00-1406). RING SHALL BEAR NO MARKING.
- (5) IF MAX ENTRY IS EXCEEDED, A 2 PIECE BACKSHELL ASSEMBLY (TYPE 2) IS SUPPLIED.
6. BACKSHELL MATES TO MIL-DTL-5015D, CLASS A, E & R, MS3100, MS3101 & MS3106. RESILIENT INSERT, SOLDER TYPE & BENDIX 10-214, CANNON CA-RX COMMERCIAL CRIMP TYPE.
- (7) ADDITIONAL PIECE(S) SUPPLIED WHEN CONNECTOR MANUFACTURER IS UNKNOWN ("D" IN TABLE 1).
- (8) ALL THREADS SIZES FOR ORDER NO. APPLY
- (9) ANTI-ROTATIONAL SET SCREW, THREE THREADED HOLES 120° ± 5° APART, SINGLE MATING SET SCREW SUPPLIED: AN565DC4H2, NOT REQUIRED FOR TYPE 2 ADAPTERS.

DRAWN	K.WINCZURA	DATE 18/12/2014	 3RD ANGLE PROJECTION NOT TO SCALE	TITLE:	<h3>TINEL-LOCK BACKSHELL</h3>	 Polamco 		
CHECKED		18/12/2014		ASSY USED ON:				
APPROVED	K.SHEPPARD	19/12/2014	UNLESS OTHERWISE SPECIFIED ALL DIMENSIONS IN MILLIMETRES GENERAL TOL LINEAR +/-0.25MM ANGULAR +/- 1°				MIL-DTL-5015D	
APPROVED	H.SMITH	07/07/2015						
REVISIONS								
LTR	DESCRIPTION	DATE	APPROVED					
J	REVISED PER ECO-15-002435	18/02/2015	H.SMITH					
K	REVISED PER ECO-15-009990	07/07/2015	H.SMITH					
TE CAGE CODE: 06090 POLAMCO/TE CAGE CODE: U5792				TE CONNECTIVITY - POLAMCO LTD RESERVES THE RIGHT TO AMEND THIS DRAWING AND THE INFORMATION SET FORTH HEREON AT ANY TIME. USERS SHOULD INDEPENDENTLY EVALUATE THE SUITABILITY OF THE PRODUCT FOR THEIR APPLICATION.		DRAWING NO: TXR18	DRAWING REV: K	SHT 1

IF MAX ENTRY IS EXCEEDED BACKSHELL WILL BE SUPPLIED AS TYPE 2

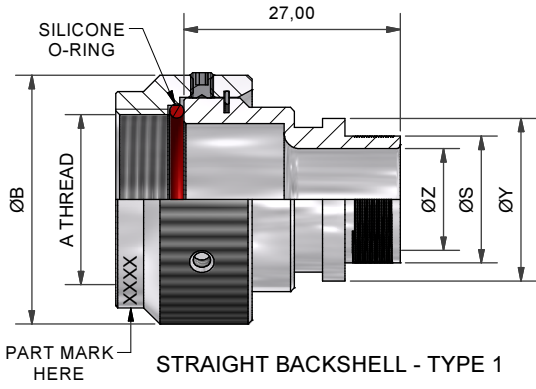

STRAIGHT BACKSHELL - TYPE 1

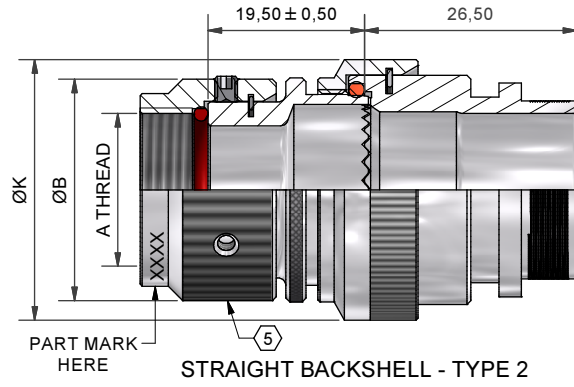

STRAIGHT BACKSHELL - TYPE 2

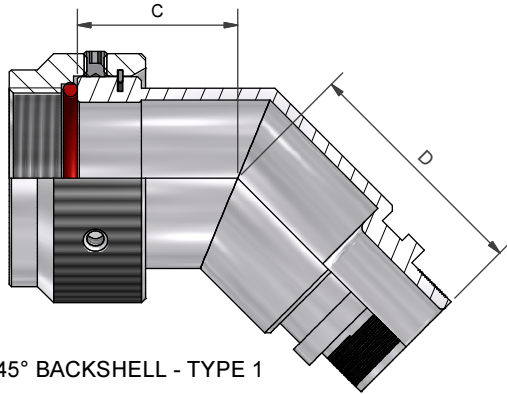

45° BACKSHELL - TYPE 1

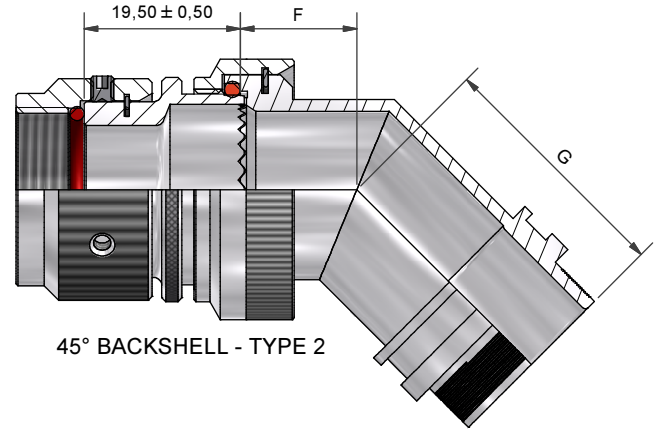

45° BACKSHELL - TYPE 2

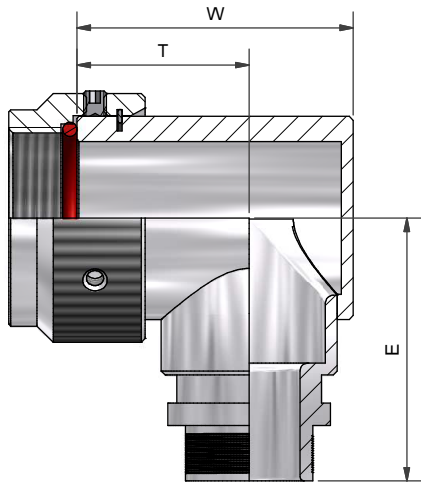

90° BACKSHELL - TYPE 1

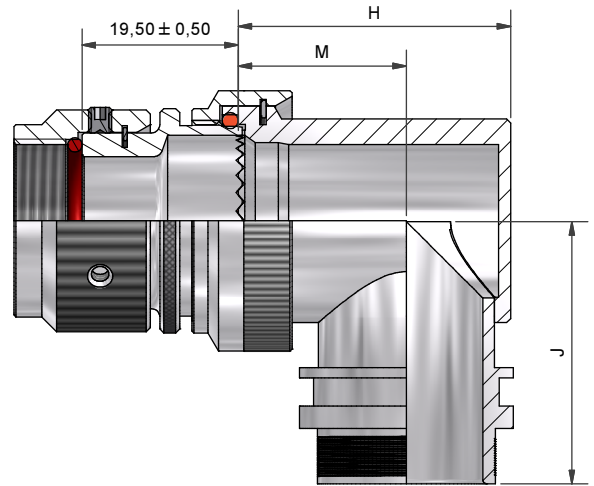

90° BACKSHELL - TYPE 2

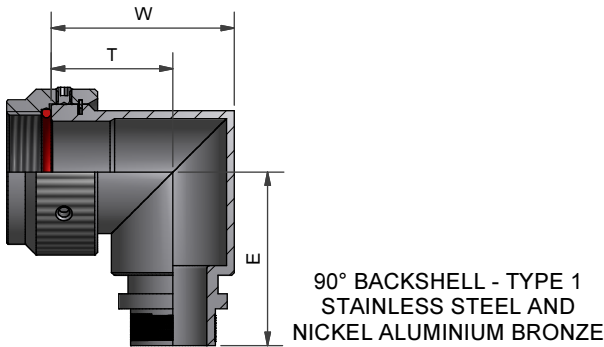

90° BACKSHELL - TYPE 1
STAINLESS STEEL AND
NICKEL ALUMINIUM BRONZE

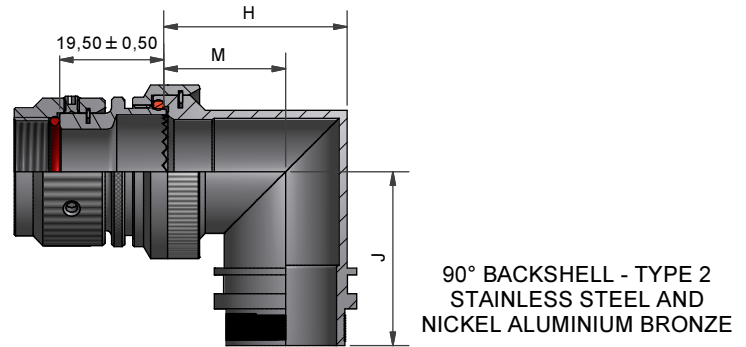

90° BACKSHELL - TYPE 2
STAINLESS STEEL AND
NICKEL ALUMINIUM BRONZE

DRAWN	K.WINCZURA	DATE	18/12/2014
CHECKED		DATE	18/12/2014
APPROVED	K.SHEPPARD	DATE	19/12/2014
APPROVED	H.SMITH	DATE	07/07/2015

3RD ANGLE PROJECTION NOT TO SCALE

UNLESS OTHERWISE SPECIFIED ALL DIMENSIONS IN MILLIMETRES
GENERAL TOL
LINEAR +/-0.25MM
ANGULAR +/- 1°

TITLE:
TINEL-LOCK BACKSHELL

ASSY USED ON:
MIL-DTL-5015D

REVISIONS			
LTR	DESCRIPTION	DATE	APPROVED
J	REVISED PER ECO-15-002435	18/02/2015	H.SMITH
K	REVISED PER ECO-15-009990	07/07/2015	H.SMITH

TE CAGE CODE: 06090
POLAMCO/TE CAGE CODE: U5792

TE CONNECTIVITY - POLAMCO LTD RESERVES THE RIGHT TO AMEND THIS DRAWING AND THE INFORMATION SET FORTH HEREON AT ANY TIME. USERS SHOULD INDEPENDENTLY EVALUATE THE SUITABILITY OF THE PRODUCT FOR THEIR APPLICATION.

Polamco
TE connectivity

DRAWING NO:	DRAWING REV:	SHT
TXR18	K	2

TABLE 1

ORDER NUMBER	SHELL SIZE	MFR CODE TABLE 3	MAX ENTRY	A THREAD	ØB MAX	C ±0,5	D ±0,5	W ±0,5	T ±0,5	E ±0,5	THESE DIMENSIONS APPLY IF BACKSHELL IS STAINLESS STEEL OR NICKEL ALUMINIUM BRONZE		
											W ±0,5	T ±0,5	E ±0,5
08	8S	B	04	3/8-32 UNEF	18,5	15,0	20,1	21,7	15,2	26,0	21,7	15,2	29,0
	8S	C	04	7/16-28 UNEF	18,1	15,0	20,1	21,7	15,2	26,0	21,7	15,2	29,0
	8S	A, R	04	7/16-27 UNS	18,5	15,0	20,1	21,7	15,2	26,0	21,7	15,2	29,0
	8S	D (8)	04	(7)	18,5	15,0	20,1	21,7	15,2	26,0	21,7	15,2	29,0
10	10S	-	06	1/2-28 UNEF	19,8	15,4	21,6	23,2	15,7	27,7	23,2	15,7	31,2
11	10SL	C	07	9/16-24 UNEF	21,6	18,4	21,6	25,0	16,5	27,7	27,2	17,5	33,0
	10SL	A, B, R	07	5/8-24 UNEF	23,2	18,4	21,6	27,2	17,5	27,7	27,2	17,5	33,0
	10SL	D (8)	07	(7)	23,2	18,4	21,6	27,2	17,5	27,7	27,2	17,5	33,0
12	12 & 12S	B, C	08	5/8-24 UNEF	23,0	18,4	21,6	27,2	17,5	27,7	27,2	17,5	33,0
	12 & 12S	A, R	08	11/16-24 UNEF	24,9	18,4	21,6	27,2	17,5	27,7	27,2	17,5	33,0
	12 & 12S	D (8)	08	(7)	24,9	18,4	21,6	27,2	17,5	27,7	27,2	17,5	33,0
14	14 & 14S	-	10	3/4-20 UNEF	27,7	19,3	22,2	30,7	19,5	30,7	30,7	19,5	34,9
16	16 & 16S	-	12	7/8-20 UNEF	31,1	20,0	23,6	34,2	21,5	32,4	34,2	21,5	35,5
18	18	-	12	1-20 UNEF	34,4	20,6	23,7	37,2	23,0	34,0	37,2	23,0	37,2
20	20	A, B, C	16	1 1/8-18 UNEF	37,6	21,3	24,6	40,7	24,5	35,6	40,7	24,5	38,7
	20	R	16	1 1/8-24 UNS	37,6	21,3	24,6	40,7	24,5	35,6	40,7	24,5	38,7
	20	D (8)	16	(7)	37,6	21,3	24,6	40,7	24,5	35,6	40,7	24,5	38,7
22	22	-	18	1 1/4-18 UNEF	40,6	21,9	25,0	43,7	26,0	37,1	43,7	26,0	40,2
24	24	-	20	1 3/8-18 UNEF	43,6	22,5	25,4	46,7	27,5	38,6	46,7	27,5	44,9
28	28	-	22	1 5/8-18 UNEF	48,6	23,6	25,4	51,7	30,0	41,1	51,7	30,0	46,0
32	32	B, C	24	1 7/8-16 UN	54,9	24,9	27,5	58,4	32,7	44,5	58,4	32,2	51,3
	32	A, R	24	1 29/32-18 UN	54,9	24,9	27,5	58,4	32,7	44,5	58,4	32,2	51,3
	32	D (8)	24	(7)	54,9	24,9	27,5	58,4	32,7	44,5	58,4	32,2	51,3
36	36	B	24	2 1/16-16 UNS	64,6	27,5	29,0	67,7	38,0	49,1	67,7	38,0	54,3
	36	R	24	2 1/16-20 UNS	64,6	27,5	29,0	67,7	38,0	49,1	67,7	38,0	54,3
	36	C	24	2 1/8-16 UN	64,6	27,5	29,0	67,7	38,0	49,1	67,7	38,0	54,3
	36	A	24	2 1/8-18 UNS	64,6	27,5	29,0	67,7	38,0	49,1	67,7	38,0	54,3
	36	D (8)	24	(7)	64,6	27,5	29,0	67,7	38,0	49,1	67,7	38,0	54,3
40	40	B	24	2 5/16-16 UN	70,6	30,1	30,1	72,2	41,1	51,3	72,2	41,1	57,5
	40	A, C, R	24	2 3/8-16 UN	70,6	30,1	30,1	72,2	41,1	51,3	72,2	41,1	57,5
	40	D (8)	24	(7)	69,3	30,1	30,1	72,2	41,1	51,3	72,2	41,1	57,5
44	44	-	24	2 5/8-16 UN	82,0	30,1	30,1	77,6 MAX	41,1	51,3	72,2	41,1	57,5
48	48	C	24	2 13/16-18 UNS	82,0	31,3	38,5	84,0 MAX	44,1	57,5	75,5	40,8	57,5
	48	A, R	24	2 7/8-16 UN	82,0	31,3	38,5	84,0 MAX	47,2	57,5	75,5	40,8	57,5
	48	D (8)	24	(7)	82,0	31,3	38,5	84,0 MAX	47,2	57,5	75,5	40,8	57,5

TABLE 2

ENTRY SIZE	ØZ MIN	ØS	ØY ±0,3	ØK MAX	F ±0,5	G ±0,5	H ±0,5	M ±0,5	J ±0,5	THESE DIMENSIONS APPLY IF BACKSHELL IS STAINLESS STEEL OR NICKEL ALUMINIUM BRONZE		
										H ±0,5	M ±0,5	J ±0,5
04	6,35	9,49 +/-0,04	14,00	NA	NA	NA	NA	NA	NA	NA	NA	NA
05	7,92	11,06 +/-0,04	15,50	21,0	12,5	27,5	24,0	15,5	27,95	24,3	17,2	28,2
06	9,53	12,66 +/-0,04	17,10	21,0	12,5	27,5	24,0	15,5	27,95	24,3	17,2	28,2
07	11,10	14,21 +/-0,07	18,70	21,0	12,5	27,5	24,0	15,5	27,95	24,3	17,2	28,2
08	12,70	15,81 +/-0,07	20,30	24,5	13,1	28,0	27,0	17,0	29,45	28,3	19,4	29,7
10	15,88	18,96 +/-0,08	23,50	29,0	13,5	29,0	31,0	19,5	31,00	31,1	21,0	31,2
12	19,05	22,14 +/-0,08	26,70	32,5	14,5	29,7	34,0	21,0	32,70	34,2	22,8	32,9
14	22,23	25,30 +/-0,08	29,80	35,5	15,5	30,5	35,0	20,0	34,25	38,5	25,3	34,5
16	25,40	28,48 +/-0,08	33,00	37,0	16,1	30,9	38,0	21,5	35,80	40,7	26,1	36,1
18	28,58	31,65 +/-0,08	36,20	40,0	16,5	31,1	42,0	24,0	37,40	43,7	27,6	37,6
20	31,75	34,83 +/-0,08	39,40	43,5	17,0	32,1	45,0	25,5	38,90	46,4	29,1	39,1
22	34,93	37,98 +/-0,08	42,50	48,5	18,5	35,3	54,5	31,0	42,00	50,0	31,0	42,0
24	38,10	41,15 +/-0,08	45,70	52,1	21,9	38,1	58,0	33,0	46,00	53,5	33,0	46,0

TABLE 3

MFR CODE	CONNECTOR MANUFACTURER (MS 3100, MS 3101 & MS 3106)
A	AMPHENOL - CLASS A
B	BENDIX - CLASS A, E & R
C	CANNON - CLASS A, E & R
D	MFR UNKNOWN, CLASS A, E & R
R	AMPHENOL - CLASS R
-	MFR CODE NOT REQUIRED

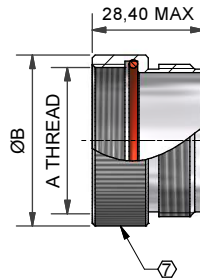



DRAWN	K.WINCZURA	DATE	18/12/2014	 3RD ANGLE PROJECTION NOT TO SCALE UNLESS OTHERWISE SPECIFIED ALL DIMENSIONS IN MILLIMETRES GENERAL TOL LINEAR +/-0,25MM ANGULAR +/- 1°
CHECKED		DATE	18/12/2014	
APPROVED	K.SHEPPARD	DATE	19/12/2014	
APPROVED	H.SMITH	DATE	07/07/2015	
REVISIONS				
LTR	DESCRIPTION	DATE	APPROVED	
J	REVISED PER ECO-15-002435	18/02/2015	H.SMITH	
K	REVISED PER ECO-15-009990	07/07/2015	H.SMITH	
TE CAGE CODE: 06090 POLAMCO/TE CAGE CODE: U5792				

TITLE:	TINEL-LOCK BACKSHELL		
ASSY USED ON:	MIL-DTL-5015D		
TE CONNECTIVITY - POLAMCO LTD RESERVES THE RIGHT TO AMEND THIS DRAWING AND THE INFORMATION SET FORTH HEREON AT ANY TIME. USERS SHOULD INDEPENDENTLY EVALUATE THE SUITABILITY OF THE PRODUCT FOR THEIR APPLICATION.	DRAWING NO:	DRAWING REV:	SHT
	TXR18	K	3

Looking for pricing, stock, or lifecycle information?

Click below to explore more details on WIN SOURCE:

-  [View TXR18AB00D2008AI on WIN SOURCE](#)
-  [TE Connectivity Information](#)

Optimize Your Supply Chain with WIN SOURCE Solutions

-  Global Sourcing Solution
-  Obsolete Management
-  Cost Control Management
-  Shortage Management
-  Alternative Solution
-  Excess Inventory Management