



FEATURES

Highest power rating with long life – Standard parts stocked*

APPLICATIONS

Wearable electronic & IoT devices – Memory backup circuits

Nominal Voltage	3.7VDC (4.2VDC to 3.0VDC)	
Operating Temperature Range	-20°C to +60°C	
Storage Temperature Range	-20°C to +60°C (one month) -20°C to +40°C (up to 3 months) -20°C to +25°C (up to 1 year)	
Storage Capacity	Nominal	See part listing 0.2C rate, 3.0V cut-off
	Minimum	See part listing 0.2C rate, 3.0V cut-off
Charging Voltage	4.2VDC \pm 0.03V	
Charging current	0.5CA	
Charging Time	< 3.0 hours	
Charging method	Constant Current/ Constant Voltage (CCCV)	
Discharge Current	Standard	0.2CA
	Maximum	2CA
Discharge Cut-off Voltage	3.0V	
Anode	Graphite	
Cathode	Lithium nickel manganese cobalt oxide	

Standard Part Listing

IC Part Number	Capacity (mAh)		Charging Current (mA)	Discharge Current (mA)		Maximum Internal Resistance (mΩ)	Weight (G)	Maximum Diameter (mm)	Height (mm)
	Nom.	Min.		STD	MAX				
RJD2048	120	110	60	24	240	700	4.2	20.	5.0
RJD2430C1	110	104	55	22	220	500	4.5	24.5	3.15
RJD2440	150	140	75	30	300	700	5.4	24.5	4.3
RJD2450	200	190	100	40	400	500	6.5	24.5	5.4
RJD3032*	200	190	100	40	400	600	7.2	30	3.4
RJD3048*	300	290	150	60	600	400	9.3	30	4.8
RJD3555*	500	490	250	100	1000	200	14	35.2	5.7

* Additional stocked standard cells with PCM (protection circuit module) & connector

RJD3032HPPV30M
RJD3048HPPV30M
D3555HPPV30M



Termination Styles

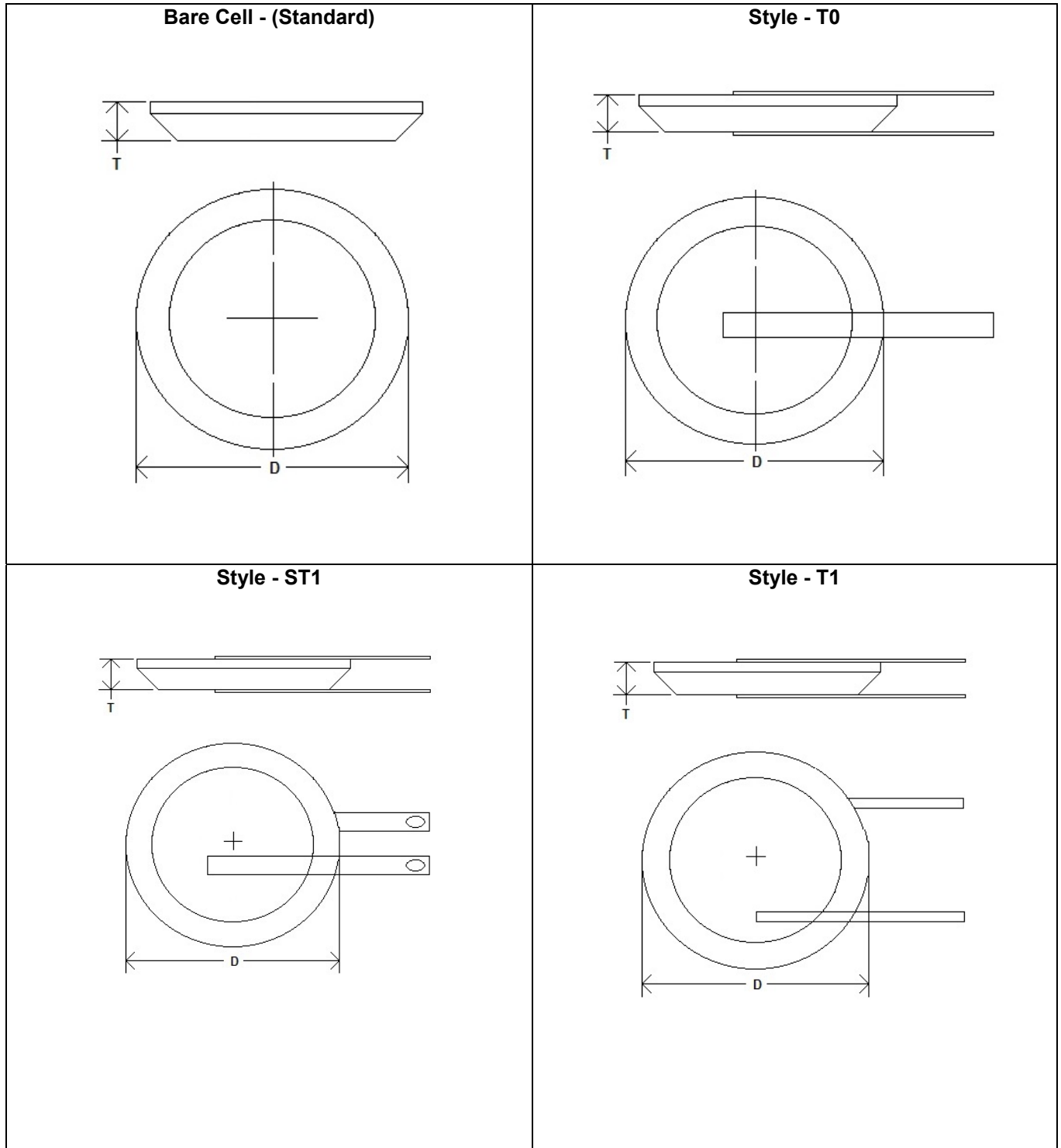



<p style="text-align: center;">Style - SP8</p>	<p style="text-align: center;">Style - ST9</p>
<p style="text-align: center;">Style - SP9</p>	<p style="text-align: center;">Style - WL</p>
<p style="text-align: center;">Style - ST8</p>	<p style="text-align: center;">Style - T9</p>

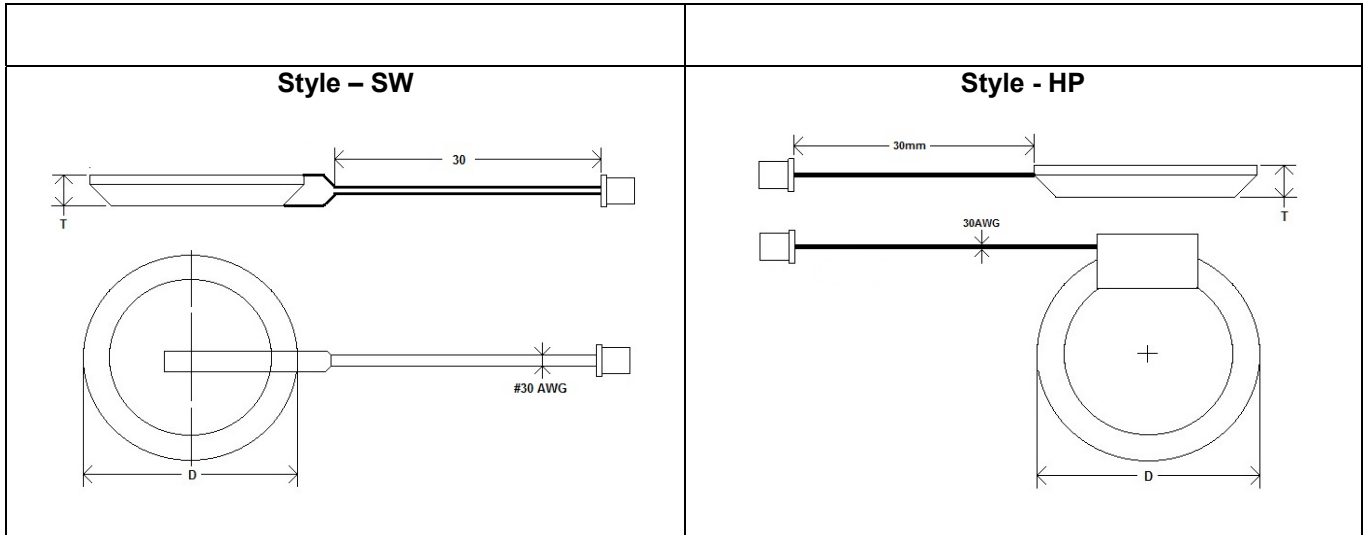

Contact IC if other termination type is preferred

Part Numbering

RJD 2032C1 AAA BBB CCC D
 Section 1 Section 2 Section 3 Section 4 Section 5

Section 1 – IC standard part number (Bare cell)

Section 2 – Optional lead style (see above options)

HP lead style can be supplied with a PCM (Protection Circuit Module). PCM is recommended.
 PCM Type: Powerlogics part # RJD9901 (see Protection Circuit Module section for complete specifications).

PCM	Included with Connector	Connector without PCM
	P	N

Section 3 - Wire gauge if other than #30AWG (Standard)

AWG	Code	AWG	Code	AWG	Code	AWG	Code	AWG	Code	AWG	Code
12	A	16	E	20	J	24	N	28	T	32	X
13	B	17	F	21	K	25	P	29	U	33	Y
14	C	18	G	22	L	26	Q	30	V	34	Z
15	D	19	H	23	M	27	R	31	W	35	O

Contact IC if other wire gauge is desired.

Section 4 – Lead Length. Specify lead length in mm.

Section 5 – Connector option (types SW and HP)

IC Code	Connector Manufacturer	Connector Part Number
M	Molex	51021-0200
J	JST	ACHR-02V-S



Markings

Standard (bare cells)

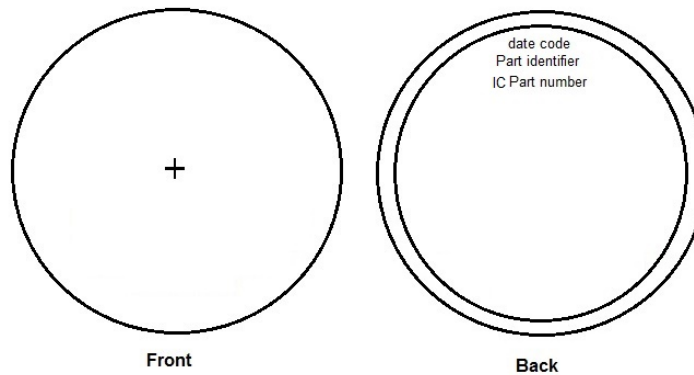

Front

Back

Non-Standard Terminations

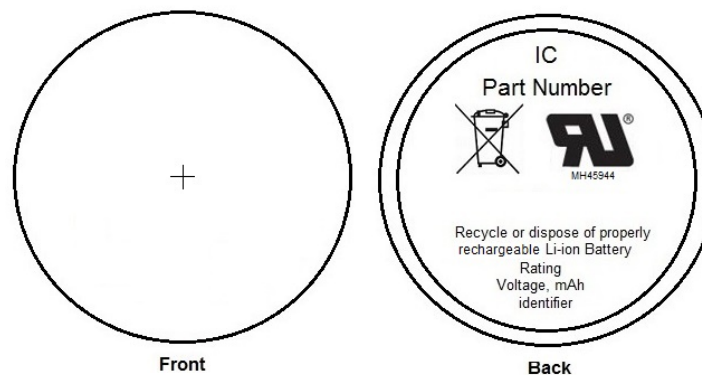

Front

Back

Cell Dimensions

IC Part Number	Fresh Cell				Cycled cell (after 500 cycles)	
	Shipping (Charged)		Full Charge		Full Charge	
	Maximum Diameter (mm)	Maximum Height (mm)	Maximum Diameter (mm)	Maximum Height (mm)	Maximum Diameter (mm)	Maximum Height (mm)
RJD2032C1	20	3.5	20	3.6	20	3.7
RJD2048	20	5	20	5.2	20	5.3
RJD2430C1	24.5	3.15	24.5	3.25	24.5	3.3
RJD2440	24.5	4.3	24.5	4.4	24.5	4.5
RJD2450	24.5	5.4	24.5	5.5	24.5	5.6
RJD3032	30	3.4	30	3.5	30	3.6
RJD3048	30	4.8	30	4.9	30	5.2
RJD3555	35.2	5.7	35.2	5.8	35.2	5.9

Protection Circuit Module



(RJD 9901)
(Optional for HP lead style)

Specification	RJD 9901	Specification	RJD 9901
Main IC	SP31ABE	Over-Discharge Detection Voltage	2.242V~2.358V
PCB	SALTEK, APEX	Over-Discharge Detection Delay Time	14.0mSec~26.0mSec
FET	X	Over-Discharge Current Detection	1.2 ~ 4.0A
PTC	MicroSMD175F-2 (TE)	Overcharge Current Detection	0.9A ~ 4.4A
L terminal	X	Over-Discharge Current Protection Delay Time	8.0mSec ~ 16.0mSec
Capacitor	2Point	Short Detection Delay Time	100μs ~ 500μs
Resistor	2Point	PCM Impedance	< 220mΩ
Dimension(L*W*T)	16.9*3.9*2.0mm	Operation Current Consumption	Max 6.0μA(TYP 4.0μA)
Wake-up Function	NO	Power-Down Mode Current Consumption	Max 0.1μA
Overcharge Detection Voltage	4.275V ± 25mV	Distance Between B+, B- Tab	13.93mm
Overcharge Detection Delay Time	700.0mSec ~ 1300mSec		

Battery Operation Instruction:

Charging

- Charge the battery in a temperature range of 0°C to + 45°C.
- Charge the battery at a constant current of 0.5C until 4.20VDC±0.03VDC per cell is attained. Charge rates greater than 1C are NOT recommended. (C: Rated Capacity of Battery)
- Maintain charge voltage at 4.20VDC per cell for 3.0 hours (recommended for maximum capacity).

* Use a constant current, constant voltage (CC/CV) lithium-ion (Li+) battery charge controller.

* Do not continue to charge battery over specified time.

Discharging

- Recommended cut-off voltage to 3.0VDC. Recommended maximum discharge rate is 2C at constant current.
- For maximum performance, discharge the battery in a temperature range of -20°C to + 45°C.



Protection Circuit

Protection circuit can be provided upon request. However, protection circuit may be omitted for most applications without damaging performance and safety. Please consult our engineering staff for technical advice.

Storage Recommendations

a. Storage Temperature and Humidity

Storage the battery at temperature range of $-20 \sim +45^{\circ}\text{C}$, low humidity and no corrosive gas atmosphere
No condensation on the battery.

b. Long Period Storage

In case of long period storage (more than 3 months), storage the battery at temperature range of $-20 \sim +25^{\circ}\text{C}$, low humidity, no corrosive gas atmosphere.

Standard Test Conditions

Unless otherwise specified, all tests are conducted at $25^{\circ}\text{C} \pm 3^{\circ}\text{C}$ and relative humidity of $65\% \pm 20\%$.

Electrical Characteristics

Standard Charge and Discharge Conditions

- A. The "Standard Charge" means charging the Cell with initial charge current (0.5C) and with a constant voltage of 4.2VDC ($\pm 0.03\text{VDC}$) and the specified cut-off current (see table 1) at 25°C for 3 hours.
- B. Standard discharge means discharging cell with constant discharge current (0.2C)(see table 1) and with 3.0VDC cut-off voltage at 25°C
- C. Initial Discharge Capacity
- D. The initial capacity measured under the standard test conditions
- E. Initial Discharge Capacity: See standard part listing
- F. Initial Internal Impedance: see standard part listing
- G. Internal resistance measured at 1 kHz after Standard Charge.
- H. Initial internal impedance: See standard part listing
- I. Cycle Life (500 cycles): See table 1
- J. Temperature dependence of discharge capacity. See discharge table.
- K. Relative capacity at each temperature measured with a constant discharge current (0.2C) with 3.0VDC cutoff after the standard charge shown below



Discharge Table

IC Part Number	Discharge Temperature			
	-20°C	-10°C	25°C	60°C
RJD2032C1	>60 %	>80%	100 %	>95%
RJD2048	>60 %	>80%	100 %	>80%
RJD2430C1	>60 %	>80%	100 %	>95%
RJD2440	>60 %	>80%	100 %	>80%
RJD2450	>60 %	>80%	100 %	>80%
RJD3032	>60 %	>80%	100 %	>80%
RJD3048	>60 %	>80%	100 %	>80%
RJD3555	>60 %	>80%	100 %	>80%

Table 1

IC Part Number	Charging Current (0.5C) (mA)	Constant Discharge Current (0.2C) (mA)	Charging end condition (at CV mode) (mA)	Capacity after 500 cycles (mAh)
RJD2032C1	40	16	2.4	56
RJD2048	60	24	3.6	77
RJD2430C1	55	22	3.3	72.8
RJD2440	75	30	4.5	98
RJD2450	100	40	6	133
RJD3032	100	40	6	133
RJD3048	150	60	9	203
RJD3555	250	100	15	350

Discharge Characteristics on Current Load (C-Rate)

Relative capacity at each load, measured with constant discharge current 0.2C, 0.5C, 1.0C, 2C with 3.0VDC cut-off after Standard Charge shown below.

Charge Current	Discharge Current			
	0.2 CA	0.5 CA	1 CA	2.0 CA
Standard Charge	100 %	> 95 %	> 90 %	> 50%

Shipment

The Cell shall be shipped with 30% of the nominal voltage. (Nominal Cell voltage range: 3.7 ~ 3.8 V). 30% SOC is only for air transport.



Storage Characteristics

After storage at the conditions listed below, the battery is measured at the standard charge and discharge condition stated above.

Storage Condition	Charge State	Capacity Retention	Capacity Recovery
20 days at 60°C	Shipping charge	-	> 85%
20 days at 60°C	Full charge	> 70%	> 85%
60 days at 60°C	Full charge	> 40%	> 60%
30 days at 60°C, 90%RH	Full charge	> 40%	> 70%

Safety Test

Test	Test Method	Criteria
High Temperature	Storing a cell at 90°C for 4 hours after being charged to 4.2VDC	No leakage
High Temperature and High Humidity	Storing a cell at 60°C for 1 week after being charged to 4.2VDC	No leakage
Thermal Shock Test	Store a fully charged cell (4.2VDC) at 60°C for 2 hours then at -20°C for 2 hours. 10 cycles with a maximum transition time of 5 minutes.	No leakage
Hot Box Test	A cell is to be heated in a gravity convection oven. The temperature of the oven is to be raised 5°C+/- 2°C per minute to a temperature of 130°C and remain at that temperature for 10 minutes	No explosion, No fire
Overcharge Test	Charge the test samples with constant current (3C) and voltage 4.5VDC. Test samples remain on test for 2.5 hours	No explosion, No fire
Impact Test	A test cell is to be placed on a flat surface. The bar of 9.1 kg weight and 15.8 mm diameter is dropped from a height of 610 mm onto the cell.	No explosion, No fire
Short-Circuit Test	A cell is to be short-circuited by connecting the positive and negative terminals of the battery with copper wire having a maximum resistance load of 100mΩ.	No fire or explosion, until battery is completely discharged
Nail Test	A stainless steel nail having a diameter of 4.0 mm is punched through the cell until the nail has passed through the opposite side of the cell.	No explosion, No fire
Applying Pressure	Placing pressure on entire surface of a fully charged cell with 7kg for 72 hours	No leakage, No weight decrease

Precautions and Safety Instructions

Lithium-Ion rechargeable batteries subjected to abusive conditions can become damaged and/or cause personal injury. Please read and observe the standard battery precautions below before using.

Note 1. The customer is required to contact Illinois Capacitor in advance, if and when the customer needs other applications or operating conditions other than those described in this document.



Note 2. Illinois Capacitor will take no responsibility for any accident where the cell is used under other conditions than those described in this document.

Precautions and Safety Instructions:

- a. Do not expose the battery to extreme heat or flame.
- b. Do not short circuit, over-charge or over-discharge the battery.
- c. Do not subject the battery to strong mechanical shocks.
- d. Do not immerse the battery in water or sea water, or get it wet.
- e. Do not reverse the polarity of the battery for any reason.
- f. Do not disassemble or modify the battery.
- g. Do not remove charge/discharge protection circuitry.
- h. Do not handle or store with metallic objects like necklaces, coins or hairpins, etc.
- i. Do not use the battery with possible damage or deformation.
- j. Do not connect battery to the plug socket or car-cigarette-plug.
- k. Do not make the direct soldering onto a battery. Spot weld lead plate onto a battery. Soldering iron temperature should be limited to 350°C with a soldering time of <5 seconds.
- l. Do not place batteries in a solder bath.
- m. Do not touch a leaked battery directly.
- n. Do not use for other equipment.
- o. Do not use Lithium-ion battery in mixture.
- p. Do not use or leave the battery under direct sunlight (or in heated car by sunshine).
- q. Keep battery away from children.
- r. Do use the specified charger and observe charging requirement
- s. Do not drive a nail into battery or strike battery with a battery or insert a screw into the battery
- t. Do not smash or throw battery.
- u. Recharge the battery every 6 months.
- v. Follow recommended charging conditions when charging battery.

Warnings:

- a. Do not swallow. Keep out of reach of infants and children. If swallowed call physician immediately.
- b. Do not put battery in microwave or pressure cooker.
- c. Do not use battery together with a primary battery, such as dry battery types or batteries with different capacities.
- d. Do not replace battery with a different type or model.
- e. Discontinue use of battery if an unusual odor, discoloration, deformation, internal heating or other unusual characteristic changes are detected.
- f. Do not have any leaked electrolyte come in contact with eyes. If contact occurs flush eyes immediately with water and consult a doctor.
- g. If charging does not stop after expected charging time, stop charging battery.

Requirement for Safety Assurance

For the sake of safety assurance, please discuss the equipment design, its system and protection circuit of Lithium-ion battery with Illinois capacitor in advance.

And consult about the high rate current, rapid charge and special application in the same way.

Looking for pricing, stock, or lifecycle information?

Click below to explore more details on WIN SOURCE:

 [View RJD2440 on WIN SOURCE](#)

 [Illinois Capacitor Information](#)

Optimize Your Supply Chain with WIN SOURCE Solutions

-  Global Sourcing Solution
-  Obsolete Management
-  Cost Control Management
-  Shortage Management
-  Alternative Solution
-  Excess Inventory Management