



**THE DATASHEET OF  
DAC088S085CISQ/NOPB**



# DAC088S085 8-Bit Micro Power OCTAL Digital-to-Analog Converter With Rail-to-Rail Outputs

## 1 Features

- Ensured Monotonicity
- Low Power Operation
- Rail-to-Rail Voltage Output
- Daisy Chain Capability
- Power-On Reset to 0 V
- Simultaneous Output Updating
- Individual Channel Power Down Capability
- Wide Power Supply Range (2.7 V to 5.5 V)
- Dual Reference Voltages With Range of 0.5 V to  $V_A$
- Operating Temperature Range of  $-40^{\circ}\text{C}$  to  $125^{\circ}\text{C}$
- Industry's Smallest Package
- Key Specifications
  - Resolution: 8 Bits
  - INL:  $\pm 0.5$  LSB (Maximum)
  - DNL: 0.15 /  $-0.1$  LSB (Maximum)
  - Settling Time: 4.5  $\mu\text{s}$  (Maximum)
  - Zero Code Error: 15 mV (Maximum)
  - Full-Scale Error:  $-0.75\%$ FSR (Maximum)
  - Supply Power :
    - Normal: 1.95 mW (3 V) / 4.85 mW (5 V)  
Typical
    - Power Down: 0.3  $\mu\text{W}$  (3 V) / 1  $\mu\text{W}$  (5 V)  
Typical

## 2 Applications

- Battery-Powered Instruments
- Digital Gain and Offset Adjustment
- Programmable Voltage and Current Sources
- Programmable Attenuators
- Voltage Reference for ADCs
- Sensor Supply Voltage
- Range Detectors

## 3 Description

The DAC088S085 is a full-featured, general-purpose, OCTAL, 8-bit, voltage-output, digital-to-analog converter (DAC) that can operate from a single 2.7 V to 5.5 V supply and consumes 1.95 mW at 3 V and 4.85 mW at 5 V. The DAC088S085 is packaged in a 16-pin WQFN package and a 16-pin TSSOP package. The WQFN package makes the DAC088S085 the smallest OCTAL DAC in its class. The on-chip output amplifiers allow rail-to-rail output swing and the three-wire serial interface operates at clock rates up to 40 MHz over the entire supply voltage range. Competitive devices are limited to 25-MHz clock rates at supply voltages in the range of 2.7 V to 3.6 V. The serial interface is compatible with standard SPI™, QSPI, MICROWIRE, and DSP interfaces. The DAC088S085 also offers daisy chain operation where an unlimited number of devices can be updated simultaneously using a single serial interface.

### Device Information<sup>(1)</sup>

PART NUMBER	PACKAGE	BODY SIZE (NOM)
DAC088S085	TSSOP (16)	5.00 mm x 4.40 mm
	WQFN (16)	4.00 mm x 4.00 mm

(1) For all available packages, see the orderable addendum at the end of the data sheet.

### DNL vs Code

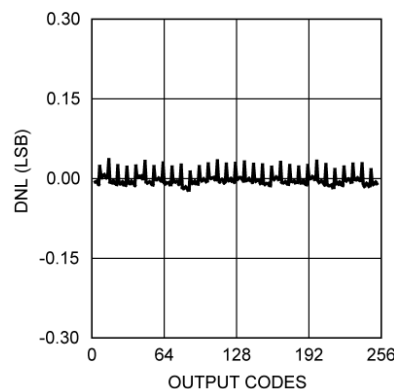

## Table of Contents

<b>1 Features</b> .....	<b>1</b>	8.4 Device Functional Modes .....	<b>16</b>
<b>2 Applications</b> .....	<b>1</b>	8.5 Programming .....	<b>17</b>
<b>3 Description</b> .....	<b>1</b>	<b>9 Application and Implementation</b> .....	<b>20</b>
<b>4 Revision History</b> .....	<b>2</b>	9.1 Application Information .....	<b>20</b>
<b>5 Description (continued)</b> .....	<b>3</b>	9.2 Typical Applications .....	<b>25</b>
<b>6 Pin Configuration and Functions</b> .....	<b>3</b>	9.3 Do's and Don'ts .....	<b>27</b>
<b>7 Specifications</b> .....	<b>5</b>	<b>10 Power Supply Recommendations</b> .....	<b>27</b>
7.1 Absolute Maximum Ratings .....	<b>5</b>	10.1 Using References as Power Supplies .....	<b>27</b>
7.2 ESD Ratings .....	<b>5</b>	<b>11 Layout</b> .....	<b>29</b>
7.3 Recommended Operating Conditions .....	<b>5</b>	11.1 Layout Guidelines .....	<b>29</b>
7.4 Thermal Information .....	<b>6</b>	11.2 Layout Example .....	<b>30</b>
7.5 Electrical Characteristics .....	<b>6</b>	<b>12 Device and Documentation Support</b> .....	<b>31</b>
7.6 AC and Timing Requirements .....	<b>8</b>	12.1 Device Support .....	<b>31</b>
7.7 Typical Characteristics .....	<b>9</b>	12.2 Community Resources .....	<b>32</b>
<b>8 Detailed Description</b> .....	<b>14</b>	12.3 Trademarks .....	<b>32</b>
8.1 Overview .....	<b>14</b>	12.4 Electrostatic Discharge Caution .....	<b>32</b>
8.2 Functional Block Diagram .....	<b>14</b>	12.5 Glossary .....	<b>32</b>
8.3 Feature Description .....	<b>15</b>	<b>13 Mechanical, Packaging, and Orderable Information</b> .....	<b>32</b>

## 4 Revision History

NOTE: Page numbers for previous revisions may differ from page numbers in the current version.

### Changes from Revision C (March 2013) to Revision D

Page

- Added *ESD Ratings* table, *Feature Description* section, *Device Functional Modes*, *Application and Implementation* section, *Power Supply Recommendations* section, *Layout* section, *Device and Documentation Support* section, and *Mechanical, Packaging, and Orderable Information* section .....

**1**

### Changes from Revision B (March 2013) to Revision C

Page

- Changed layout of National Data Sheet to TI format .....

**29**

## 5 Description (continued)

There are two references for the DAC088S085. One reference input serves channels A through D, while the other reference serves channels E through H. Each reference can be set independently between 0.5 V and  $V_A$ , providing the widest possible output dynamic range. The DAC088S085 has a 16-bit input shift register that controls the mode of operation, the power-down condition, and the DAC channels' register and output value. All eight DAC outputs can be updated simultaneously or individually.

A power-on reset circuit ensures that the DAC outputs power up to 0 V and remain there until there is a valid write to the device. The power-down feature of the DAC088S085 allows each DAC to be independently powered with three different termination options. With all the DAC channels powered down, power consumption reduces to less than 0.3  $\mu\text{W}$  at 3 V and less than 1  $\mu\text{W}$  at 5 V. The low power consumption and small packages of the DAC088S085 make it an excellent choice for use in battery-operated equipment.

The DAC088S085 is one of a family of pin-compatible DACs, including the 10-bit DAC108S085 and the 12-bit DAC128S085. All three parts are offered with the same pinout, allowing system designers to select a resolution appropriate for their application without redesigning their printed-circuit board. The DAC088S085 operates over the extended industrial temperature range of  $-40^\circ\text{C}$  to  $125^\circ\text{C}$ .

## 6 Pin Configuration and Functions

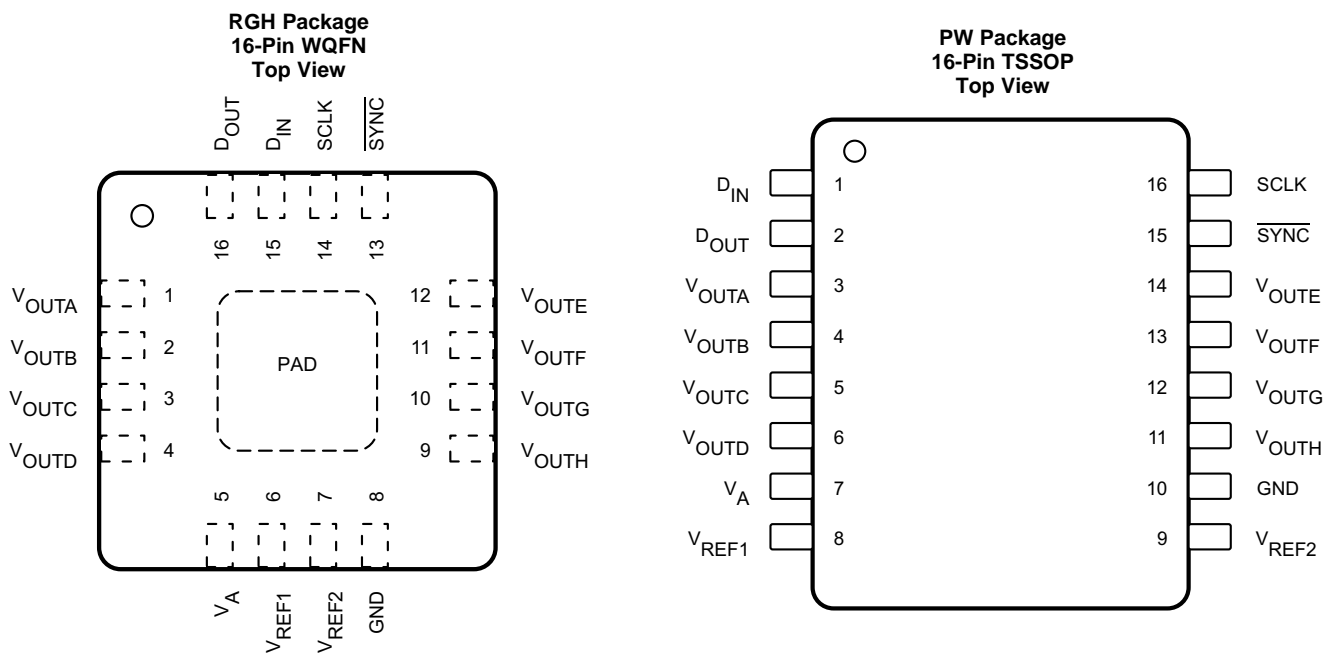

### Pin Functions

NAME	PIN		TYPE	DESCRIPTION
	NO.			
	WQFN	TSSOP		
D <sub>IN</sub>	15	1	Digital Input	Serial Data Input. Data is clocked into the 16-bit shift register on the falling edges of SCLK after the fall of SYNC.
D <sub>OUT</sub>	16	2	Digital Output	Serial Data Output. D <sub>OUT</sub> is used in daisy chain operation and is connected directly to a D <sub>IN</sub> pin on another DAC088S085. Data is not available at D <sub>OUT</sub> unless SYNC remains low for more than 16 SCLK cycles.
GND	8	10	Ground	Ground reference for all on-chip circuitry.
SCLK	14	16	Digital Input	Serial Clock Input. Data is clocked into the input shift register on the falling edges of this pin.
SYNC	13	15	Digital Input	Frame Synchronization Input. When this pin goes low, data is written into the DAC's input shift register on the falling edges of SCLK. After the 16th falling edge of SCLK, a rising edge of SYNC causes the DAC to be updated. If SYNC is brought high before the 15th falling edge of SCLK, the rising edge of SYNC acts as an interrupt and the write sequence is ignored by the DAC.
V <sub>A</sub>	5	7	Supply	Power supply input. Must be decoupled to GND.
V <sub>OUTA</sub>	1	3	Analog Output	Channel A Analog Output Voltage.
V <sub>OUTB</sub>	2	4	Analog Output	Channel B Analog Output Voltage.
V <sub>OUTC</sub>	3	5	Analog Output	Channel C Analog Output Voltage.
V <sub>OUTD</sub>	4	6	Analog Output	Channel D Analog Output Voltage.
V <sub>OUTE</sub>	12	14	Analog Output	Channel E Analog Output Voltage.
V <sub>OUTF</sub>	11	13	Analog Output	Channel F Analog Output Voltage.
V <sub>OUTG</sub>	10	12	Analog Output	Channel G Analog Output Voltage.
V <sub>OUTH</sub>	9	11	Analog Output	Channel H Analog Output Voltage.
V <sub>REF1</sub>	6	8	Analog Input	Unbuffered reference voltage shared by Channels A, B, C, and D. Must be decoupled to GND.
V <sub>REF2</sub>	7	9	Analog Input	Unbuffered reference voltage shared by Channels E, F, G, and H. Must be decoupled to GND.
PAD <sup>(1)</sup>	—	—	Ground	Exposed die attach pad can be connected to ground or left floating. Soldering the pad to the PCB offers optimal thermal performance and enhances package self-alignment during reflow.

(1) WQFN only

## 7 Specifications

### 7.1 Absolute Maximum Ratings

over operating free-air temperature range (unless otherwise noted)<sup>(1)(2)(3)</sup>

	MIN	MAX	UNIT
Supply voltage, $V_A$		6.5	V
Voltage on any input pin	-0.3	6.5	V
Input current at any pin <sup>(4)</sup>		10	mA
Package input current <sup>(4)</sup>		30	mA
Power Consumption at $T_A = 25^\circ\text{C}$		See <sup>(5)</sup>	
Junction temperature, $T_J$		150	$^\circ\text{C}$
Storage temperature, $T_{\text{stg}}$	-65	150	$^\circ\text{C}$

- Stresses beyond those listed under *Absolute Maximum Ratings* may cause permanent damage to the device. These are stress ratings only, which do not imply functional operation of the device at these or any other conditions beyond those indicated under *Recommended Operating Conditions*. Exposure to absolute-maximum-rated conditions for extended periods may affect device reliability.
- All voltages are measured with respect to GND = 0 V, unless otherwise specified.
- If Military/Aerospace specified devices are required, please contact the Texas Instruments Sales Office/Distributors for availability and specifications.
- When the input voltage at any pin exceeds 5.5 V or is less than GND, the current at that pin must be limited to 10 mA. The 30-mA maximum package input current rating limits the number of pins that can safely exceed the power supplies with an input current of 10 mA to three.
- The absolute maximum junction temperature ( $T_{J\text{max}}$ ) for this device is  $150^\circ\text{C}$ . The maximum allowable power dissipation is dictated by  $T_{J\text{max}}$ , the junction-to-ambient thermal resistance ( $R_{\theta\text{JA}}$ ), and the ambient temperature ( $T_A$ ), and can be calculated using the formula  $P_{D\text{MAX}} = (T_{J\text{max}} - T_A) / R_{\theta\text{JA}}$ . The values for maximum power dissipation is reached only when the device is operated in a severe fault condition (for example, when input or output pins are driven beyond the operating ratings, or the power supply polarity is reversed). Such conditions must always be avoided.

### 7.2 ESD Ratings

		VALUE	UNIT
$V_{\text{(ESD)}}$	Electrostatic discharge	Human-body model (HBM), per ANSI/ESDA/JEDEC JS-001 <sup>(1)</sup>	$\pm 2500$
		Charged-device model (CDM), per JEDEC specification JESD22-C101 <sup>(2)</sup>	$\pm 1000$
		Machine model (MM)	$\pm 250$

- JEDEC document JEP155 states that 500 V HBM allows safe manufacturing with a standard ESD control process.
- JEDEC document JEP157 states that 250 V CDM allows safe manufacturing with a standard ESD control process.

### 7.3 Recommended Operating Conditions

over operating free-air temperature range (unless otherwise noted)<sup>(1)</sup>

	MIN	MAX	UNIT
Operating temperature, $T_A$	-40	125	$^\circ\text{C}$
Supply voltage, $V_A$	2.7	5.5	V
Reference voltage, $V_{\text{REF1,2}}$	0.5	$V_A$	V
Digital input voltage <sup>(2)</sup>	0	5.5	V
Output load	0	1500	pF
SCLK frequency		40	MHz

- All voltages are measured with respect to GND = 0 V, unless otherwise specified.
- The inputs are protected as shown below. Input voltage magnitudes up to 5.5 V, regardless of  $V_A$ , does not cause errors in the conversion result. For example, if  $V_A$  is 3 V, the digital input pins can be driven with a 5 V logic device.

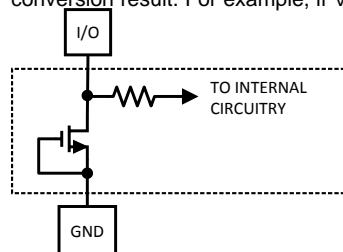

## 7.4 Thermal Information

THERMAL METRIC <sup>(1)(2)</sup>		DAC088S085		UNIT
		PW (TSSOP)	RGH (WQFN)	
		16 PINS	16 PINS	
R <sub>θJA</sub>	Junction-to-ambient thermal resistance	130	38	°C/W
R <sub>θJC(top)</sub>	Junction-to-case (top) thermal resistance	32	21	°C/W
R <sub>θJB</sub>	Junction-to-board thermal resistance	44.2	9.8	°C/W
ψ <sub>JT</sub>	Junction-to-top characterization parameter	2	0.2	°C/W
ψ <sub>JB</sub>	Junction-to-board characterization parameter	43.5	9.8	°C/W
R <sub>θJC(bot)</sub>	Junction-to-case (bottom) thermal resistance	—	2.4	°C/W

- (1) For more information about traditional and new thermal metrics, see the *Semiconductor and IC Package Thermal Metrics* application report, [SPRA953](http://www.ti.com/lit/zip/spra953).
- (2) Soldering process must comply with *Texas Instruments' Reflow Temperature Profile* specifications. See <http://www.ti.com/packaging>. Reflow temperature profiles are different for lead-free packages.

## 7.5 Electrical Characteristics

The following specifications apply for V<sub>A</sub> = 2.7 V to 5.5 V, V<sub>REF1</sub> = V<sub>REF2</sub> = V<sub>A</sub>, C<sub>L</sub> = 200 pF to GND, f<sub>SCLK</sub> = 30 MHz, input code range 3 to 252. Typical values apply for T<sub>A</sub> = 25°C; minimum and maximum limits apply for T<sub>A</sub> = –40°C to 125°C, unless otherwise specified.

PARAMETER	TEST CONDITIONS	MIN	TYP	MAX	UNIT
<b>STATIC PERFORMANCE</b>					
Resolution		8			Bits
Monotonicity		8			Bits
INL	Integral non-linearity		±0.12	±0.5	LSB
DNL	Differential non-linearity	–0.1	–0.02	0.15	LSB
ZE	Zero code error	I <sub>OUT</sub> = 0	5	15	mV
FSE	Full-scale error	I <sub>OUT</sub> = 0	–0.1	–0.75	%FSR
GE	Gain error		–0.2	–1	%FSR
ZCED	Zero code error drift		–20		μV/°C
TC GE	Gain error tempco		–1		ppm/°C
<b>OUTPUT CHARACTERISTICS</b>					
	Output voltage range	0		V <sub>REF1,2</sub>	V
I <sub>oz</sub>	High-impedance output leakage current <sup>(1)</sup>			±1	μA
ZCO	Zero code output	V <sub>A</sub> = 3 V, I <sub>OUT</sub> = 200 μA	10		mV
		V <sub>A</sub> = 3 V, I <sub>OUT</sub> = 1 mA	45		
		V <sub>A</sub> = 5 V, I <sub>OUT</sub> = 200 μA	8		
		V <sub>A</sub> = 5 V, I <sub>OUT</sub> = 1 mA	34		
FSO	Full scale output	V <sub>A</sub> = 3 V, I <sub>OUT</sub> = 200 μA	2.984		V
		V <sub>A</sub> = 3 V, I <sub>OUT</sub> = 1 mA	2.933		
		V <sub>A</sub> = 5 V, I <sub>OUT</sub> = 200 μA	4.987		
		V <sub>A</sub> = 5 V, I <sub>OUT</sub> = 1 mA	4.955		
I <sub>os</sub>	Output short circuit current (source)	V <sub>A</sub> = 3 V, V <sub>OUT</sub> = 0 V, Input Code = FFh	–50		mA
		V <sub>A</sub> = 5 V, V <sub>OUT</sub> = 0 V, Input Code = FFh	–60		
I <sub>os</sub>	Output short circuit current (sink)	V <sub>A</sub> = 3 V, V <sub>OUT</sub> = 3 V, Input Code = 00h	50		mA
		V <sub>A</sub> = 5 V, V <sub>OUT</sub> = 5 V, Input Code = 00h	70		
I <sub>o</sub>	Continuous output current per channel <sup>(1)</sup>	T <sub>A</sub> = 105°C		10	mA
		T <sub>A</sub> = 125°C		6.5	

- (1) This parameter is specified by design or characterization and is not tested in production.

## Electrical Characteristics (continued)

The following specifications apply for  $V_A = 2.7\text{ V}$  to  $5.5\text{ V}$ ,  $V_{REF1} = V_{REF2} = V_A$ ,  $C_L = 200\text{ pF}$  to GND,  $f_{SCLK} = 30\text{ MHz}$ , input code range 3 to 252. Typical values apply for  $T_A = 25^\circ\text{C}$ ; minimum and maximum limits apply for  $T_A = -40^\circ\text{C}$  to  $125^\circ\text{C}$ , unless otherwise specified.

PARAMETER		TEST CONDITIONS		MIN	TYP	MAX	UNIT
$C_L$	Maximum load capacitance	$R_L = \infty$			1500		pF
		$R_L = 2\text{ k}\Omega$			1500		
$Z_{OUT}$	DC output impedance				8		$\Omega$
<b>REFERENCE INPUT CHARACTERISTICS</b>							
$V_{REF1,2}$	input range			2.7	0.5	$V_A$	V
	Input impedance				30		k $\Omega$
<b>LOGIC INPUT CHARACTERISTICS</b>							
$I_{IN}$	Input Current <sup>(1)</sup>					$\pm 1$	$\mu\text{A}$
$V_{IL}$	Input low voltage	$V_A = 2.7\text{ V}$ to $3.6\text{ V}$			1	0.6	V
		$V_A = 4.5\text{ V}$ to $5.5\text{ V}$			1.1	0.8	
$V_{IH}$	Input high voltage	$V_A = 2.7\text{ V}$ to $3.6\text{ V}$		2.1	1.4		V
		$V_A = 4.5\text{ V}$ to $5.5\text{ V}$		2.4	2		
$C_{IN}$	Input Capacitance <sup>(1)</sup>					3	pF
<b>POWER REQUIREMENTS</b>							
$V_A$	Supply voltage			2.7		5.5	V
$I_N$	Normal supply current for supply pin $V_A$	$f_{SCLK} = 30\text{ MHz}$ , output unloaded	$V_A = 2.7\text{ V}$ to $3.6\text{ V}$		460	575	$\mu\text{A}$
			$V_A = 4.5\text{ V}$ to $5.5\text{ V}$		650	840	
	Normal supply current for $V_{REF1}$ or $V_{REF2}$	$f_{SCLK} = 30\text{ MHz}$ , output unloaded	$V_A = 2.7\text{ V}$ to $3.6\text{ V}$		95	135	
			$V_A = 4.5\text{ V}$ to $5.5\text{ V}$		160	225	
$I_{ST}$	Static supply current for supply pin $V_A$	$f_{SCLK} = 0$ , output unloaded	$V_A = 2.7\text{ V}$ to $3.6\text{ V}$		370		$\mu\text{A}$
			$V_A = 4.5\text{ V}$ to $5.5\text{ V}$		440		
	Static supply current for $V_{REF1}$ or $V_{REF2}$	$f_{SCLK} = 0$ , output unloaded	$V_A = 2.7\text{ V}$ to $3.6\text{ V}$		95		
			$V_A = 4.5\text{ V}$ to $5.5\text{ V}$		160		
$I_{PD}$	Total power down supply current for all PD Modes <sup>(1)</sup>	$f_{SCLK} = 30\text{ MHz}$ , SYNC = $V_A$ , and $D_{IN} = 0\text{ V}$ after PD mode loaded	$V_A = 2.7\text{ V}$ to $3.6\text{ V}$		0.2	1.5	$\mu\text{A}$
			$V_A = 4.5\text{ V}$ to $5.5\text{ V}$		0.5	3	
		$f_{SCLK} = 0$ , SYNC = $V_A$ , and $D_{IN} = 0\text{ V}$ after PD mode loaded	$V_A = 2.7\text{ V}$ to $3.6\text{ V}$		0.1	1	
			$V_A = 4.5\text{ V}$ to $5.5\text{ V}$		0.2	2	
$P_N$	Total power consumption (output unloaded)	$f_{SCLK} = 30\text{ MHz}$ , output unloaded	$V_A = 2.7\text{ V}$ to $3.6\text{ V}$		1.95	3	mW
			$V_A = 4.5\text{ V}$ to $5.5\text{ V}$		4.85	7.1	
		$f_{SCLK} = 0$ , output unloaded	$V_A = 2.7\text{ V}$ to $3.6\text{ V}$		1.68		
			$V_A = 4.5\text{ V}$ to $5.5\text{ V}$		3.8		
$P_{PD}$	Total power consumption in all PD Modes <sup>(1)</sup>	$f_{SCLK} = 30\text{ MHz}$ , SYNC = $V_A$ , and $D_{IN} = 0\text{ V}$ after PD mode loaded	$V_A = 2.7\text{ V}$ to $3.6\text{ V}$		0.6	5.4	$\mu\text{W}$
			$V_A = 4.5\text{ V}$ to $5.5\text{ V}$		2.5	16.5	
		$f_{SCLK} = 0$ , SYNC = $V_A$ , and $D_{IN} = 0\text{ V}$ after PD mode loaded	$V_A = 2.7\text{ V}$ to $3.6\text{ V}$		0.3	3.6	
			$V_A = 4.5\text{ V}$ to $5.5\text{ V}$		1	11	

## 7.6 AC and Timing Requirements

Test limits are specified to AOQL (Average Outgoing Quality Level). Typical values apply for  $T_A = 25^\circ\text{C}$ ; minimum and maximum limits apply for  $T_A = -40^\circ\text{C}$  to  $125^\circ\text{C}$ , unless otherwise noted.

			MIN	NOM	MAX	UNIT
$f_{\text{SCLK}}$	SCLK frequency			40	30	MHz
$t_s$	Output voltage settling time <sup>(1)</sup>	40h to C0h code change, $R_L = 2\text{ k}\Omega$ , $C_L = 200\text{ pF}$		3	4.5	$\mu\text{s}$
SR	Output Slew Rate			1		$\text{V}/\mu\text{s}$
GI	Glitch Impulse	Code change from 80h to 7Fh		40		nV-sec
DF	Digital Feedthrough			0.5		nV-sec
DC	Digital Crosstalk			0.5		nV-sec
CROSS	DAC-to-DAC crosstalk			1		nV-sec
MBW	Multiplying bandwidth	$V_{\text{REF}1,2} = 2.5\text{ V} \pm 2\text{ V}_{\text{PP}}$		360		kHz
ONSD	Output noise spectral density	DAC Code = 80h, 10 kHz		40		$\text{nV}/\sqrt{(\text{Hz})}$
ON	Output noise	BW = 30 kHz		14		$\mu\text{V}$
$t_{\text{WU}}$	Wake-up time	$V_A = 3\text{ V}$ $V_A = 5\text{ V}$		3 20		$\mu\text{s}$
$1/f_{\text{SCLK}}$	SCLK cycle time		33	25		ns
$t_{\text{CH}}$	SCLK high time		10	7		ns
$t_{\text{CL}}$	SCLK low time		10	7		ns
$t_{\text{SS}}$	$\overline{\text{SYNC}}$ set-up time before SCLK falling edge	$T_A = 25^\circ\text{C}$ $T_A = -40^\circ\text{C}$ to $125^\circ\text{C}$		3	$1/f_{\text{SCLK}} - 3$	ns
$t_{\text{DS}}$	Data set-up time before SCLK falling edge		2.5	1		ns
$t_{\text{DH}}$	Data hold time after SCLK falling edge		2.5	1		ns
$t_{\text{SH}}$	$\overline{\text{SYNC}}$ hold time after the 16th falling edge of SCLK	$T_A = 25^\circ\text{C}$ $T_A = -40^\circ\text{C}$ to $125^\circ\text{C}$		0	$1/f_{\text{SCLK}} - 3$	ns
$t_{\text{SYNC}}$	$\overline{\text{SYNC}}$ high time		15	5		ns

(1) This parameter is specified by design or characterization and is not tested in production.

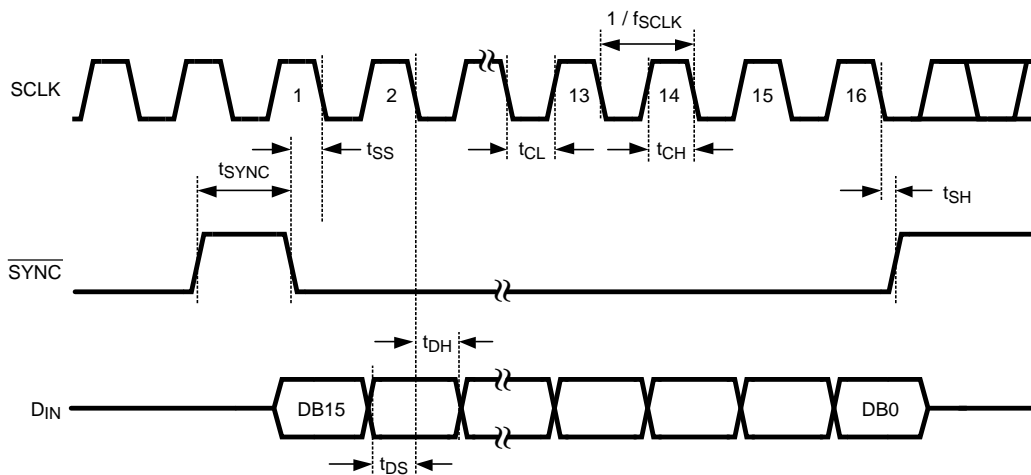

**Figure 1. Serial Timing Diagram**

## 7.7 Typical Characteristics

$V_A = 2.7\text{ V to }5.5\text{ V}$ ,  $V_{REF1,2} = V_A$ ,  $f_{SCLK} = 30\text{ MHz}$ ,  $T_A = 25^\circ\text{C}$ , unless otherwise stated

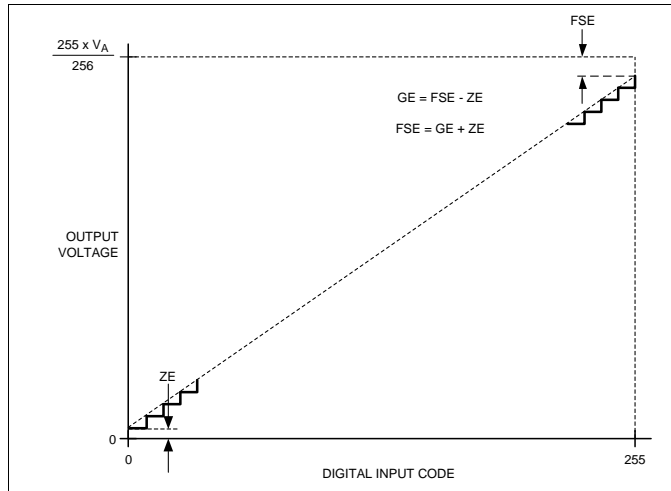

Figure 2. I/O Transfer Characteristic

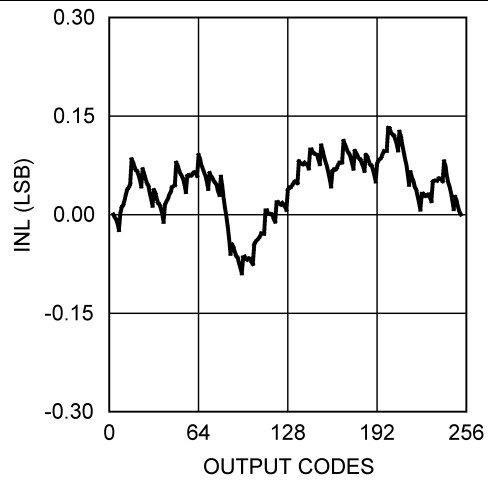

Figure 3. INL vs Code

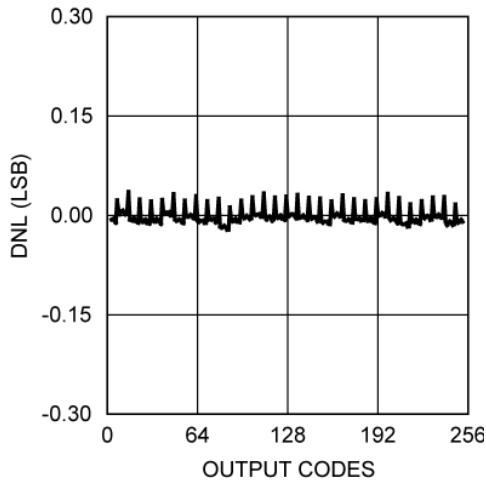

Figure 4. DNL vs Code

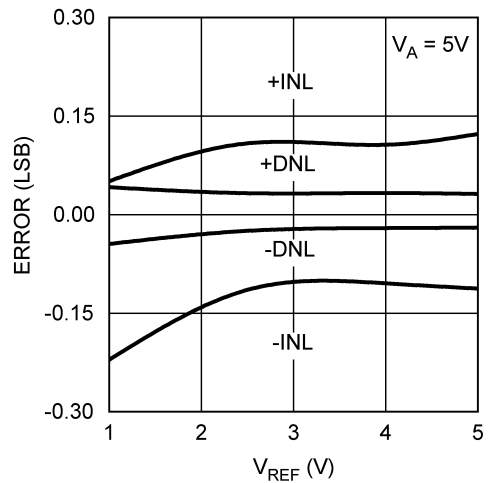

Figure 5. INL and DNL vs  $V_{REF}$

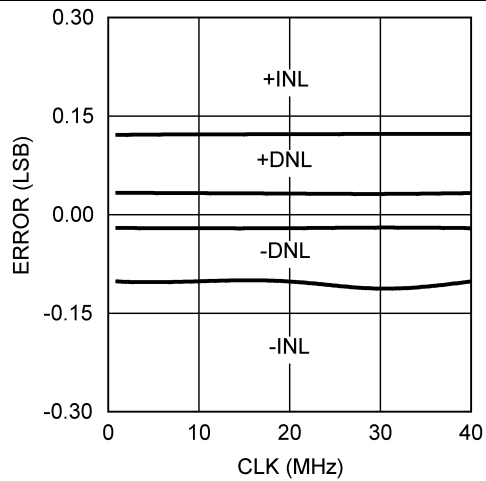

Figure 6. INL and DNL vs  $f_{SCLK}$

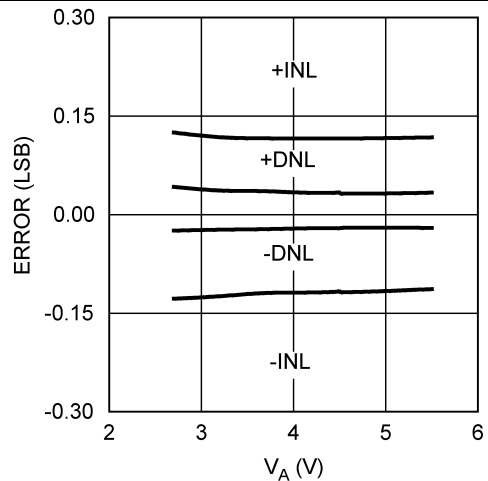
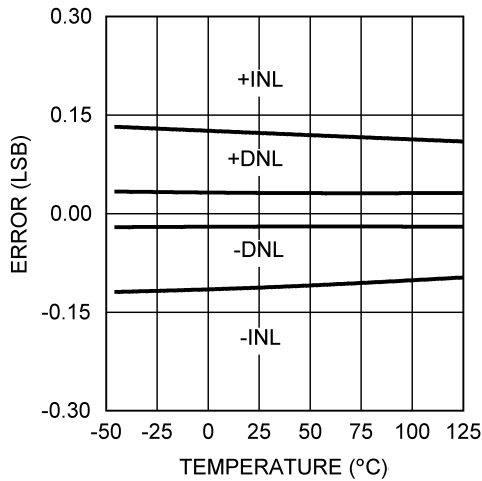
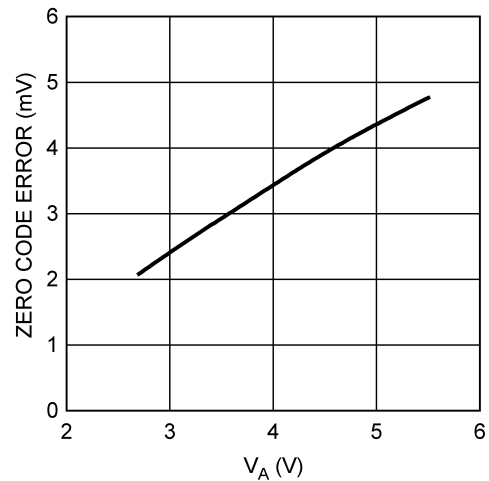
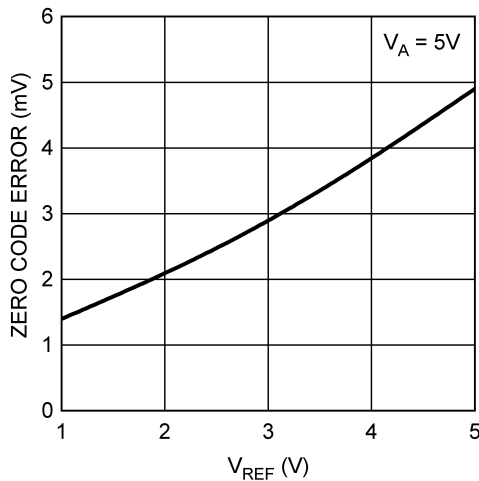
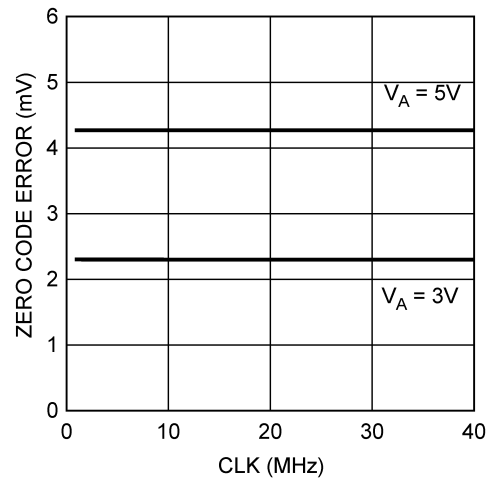
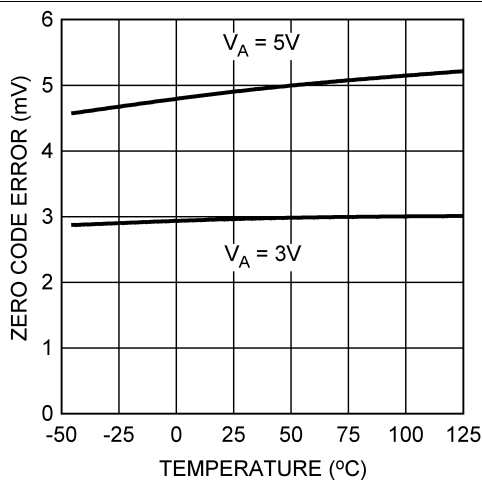
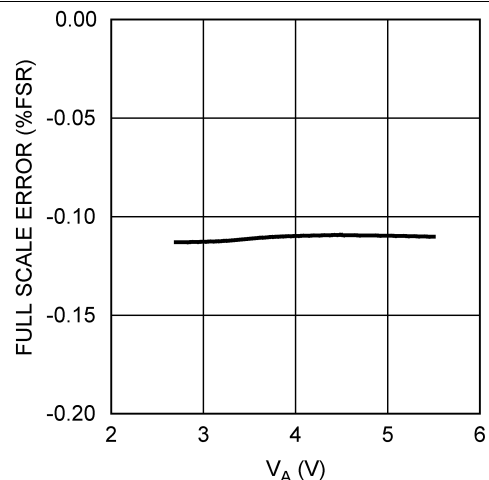

Figure 7. INL and DNL vs  $V_A$

**Typical Characteristics (continued)**
 $V_A = 2.7\text{ V to }5.5\text{ V}$ ,  $V_{REF1,2} = V_A$ ,  $f_{SCLK} = 30\text{ MHz}$ ,  $T_A = 25^\circ\text{C}$ , unless otherwise stated

**Figure 8. INL and DNL vs Temperature**

**Figure 9. Zero Code Error vs  $V_A$** 

**Figure 10. Zero Code Error vs  $V_{REF}$** 

**Figure 11. Zero Code Error vs  $f_{SCLK}$** 

**Figure 12. Zero Code Error vs Temperature**

**Figure 13. Full-Scale Error vs  $V_A$**

Typical Characteristics (continued)

$V_A = 2.7\text{ V to }5.5\text{ V}$ ,  $V_{REF1,2} = V_A$ ,  $f_{SCLK} = 30\text{ MHz}$ ,  $T_A = 25^\circ\text{C}$ , unless otherwise stated

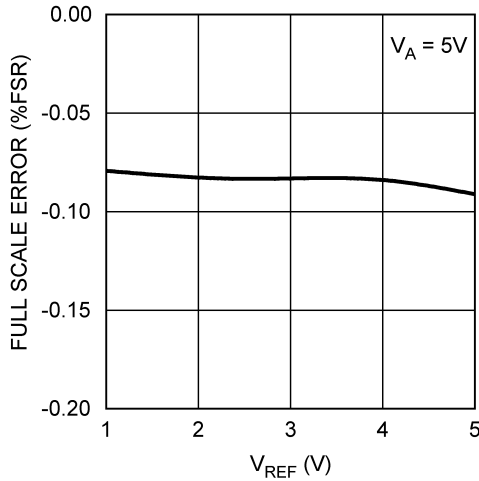

Figure 14. Full-Scale Error vs  $V_{REF}$

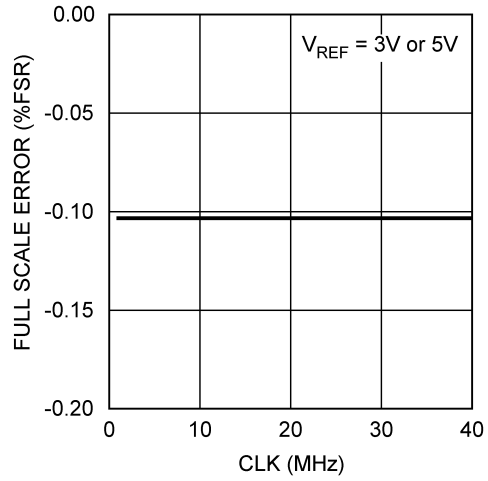

Figure 15. Full-Scale Error vs  $f_{SCLK}$

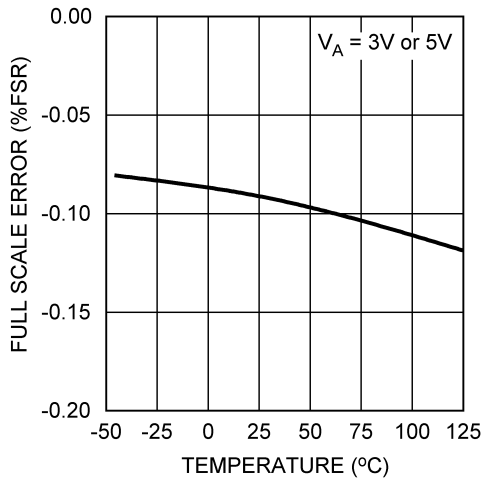

Figure 16. Full-Scale Error vs Temperature

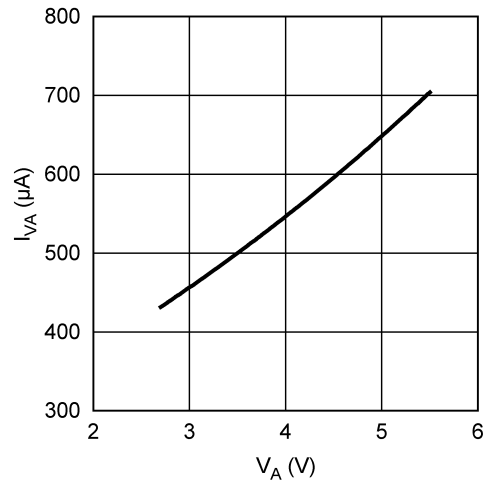

Figure 17.  $I_{VA}$  vs  $V_A$

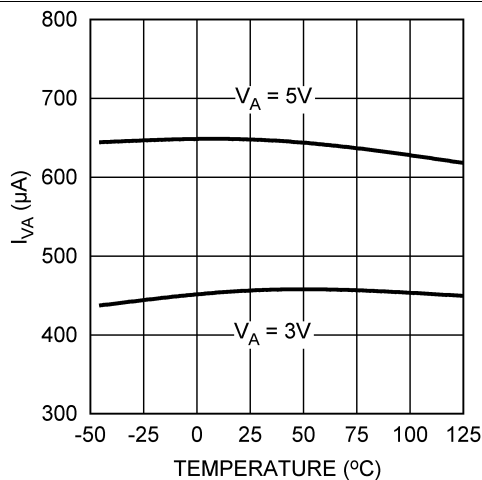

Figure 18.  $I_{VA}$  vs Temperature

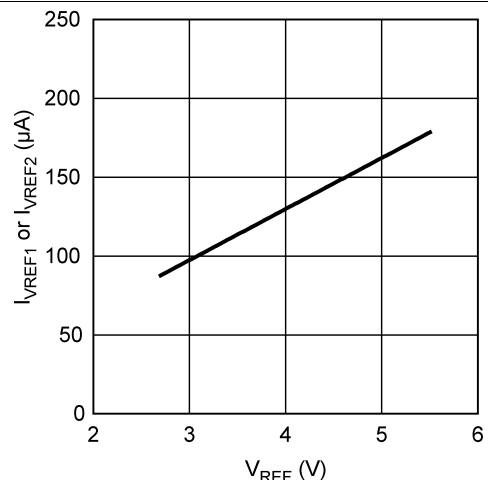

Figure 19.  $I_{VREF}$  vs  $V_{REF}$

Typical Characteristics (continued)

$V_A = 2.7\text{ V to }5.5\text{ V}$ ,  $V_{REF1,2} = V_A$ ,  $f_{SCLK} = 30\text{ MHz}$ ,  $T_A = 25^\circ\text{C}$ , unless otherwise stated

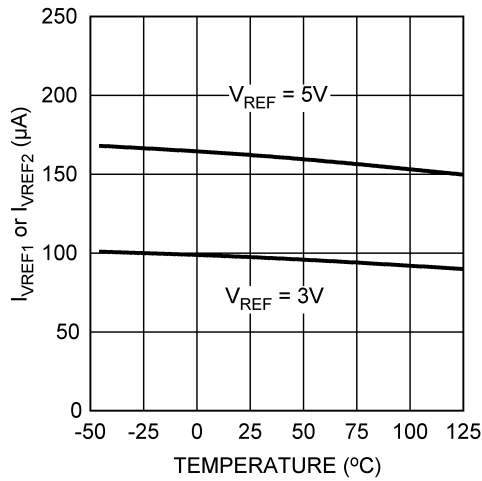

Figure 20.  $I_{VREF}$  vs Temperature

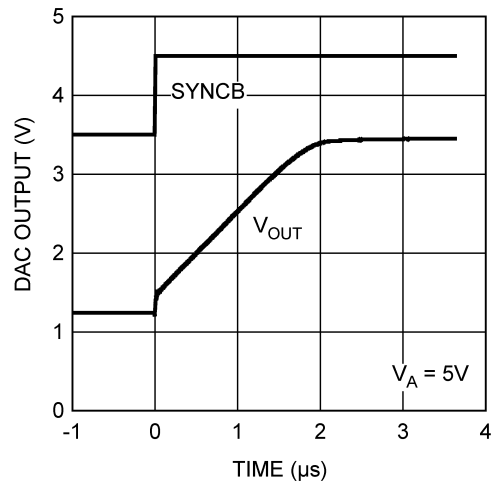

Figure 21. Settling Time

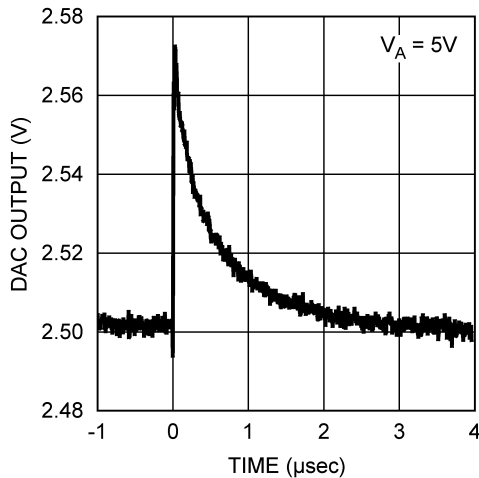

Figure 22. Glitch Response

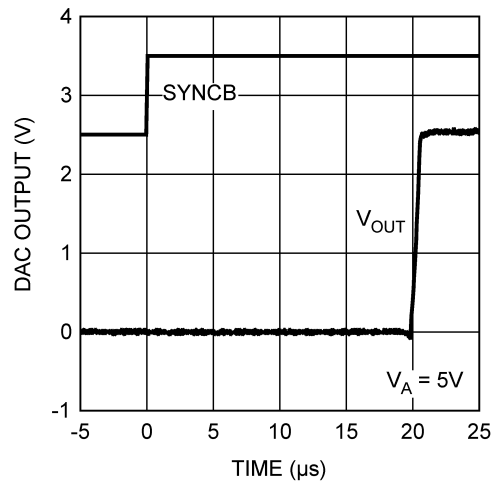

Figure 23. Wake-Up Time

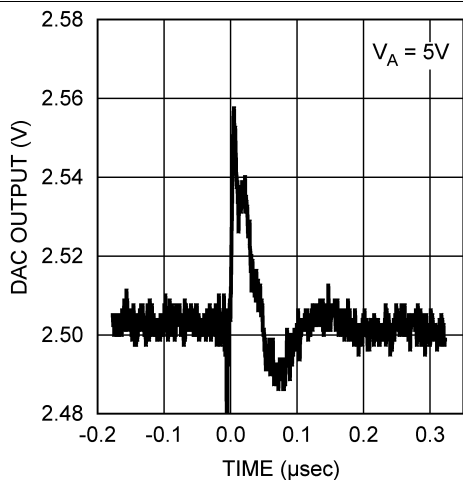

Figure 24. DAC-to-DAC Crosstalk

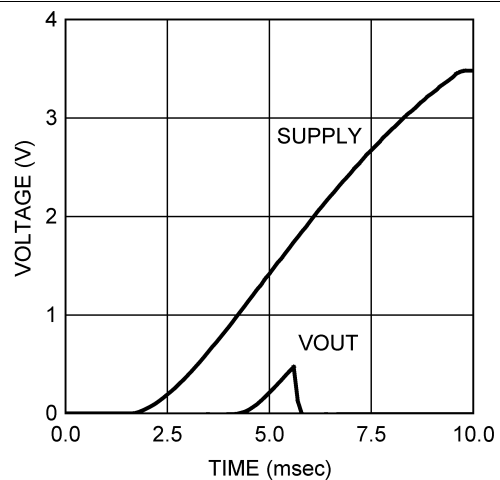
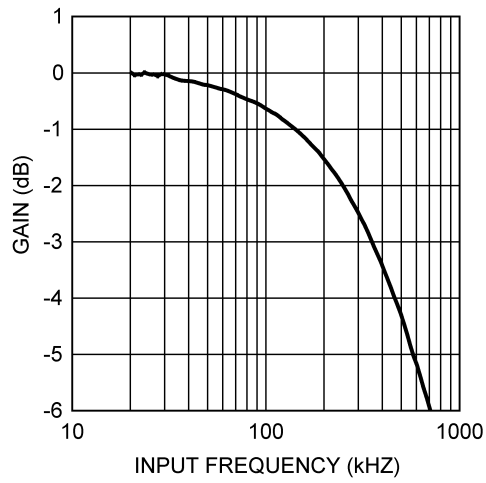

Figure 25. Power-On Reset

**Typical Characteristics (continued)**

$V_A = 2.7\text{ V to }5.5\text{ V}$ ,  $V_{REF1,2} = V_A$ ,  $f_{SCLK} = 30\text{ MHz}$ ,  $T_A = 25^\circ\text{C}$ , unless otherwise stated



**Figure 26. Multiplying Bandwidth**

## 8 Detailed Description

### 8.1 Overview

The DAC085S085 is fabricated on a CMOS process with an architecture that consists of switches and resistor strings that are followed by an output buffer.

### 8.2 Functional Block Diagram

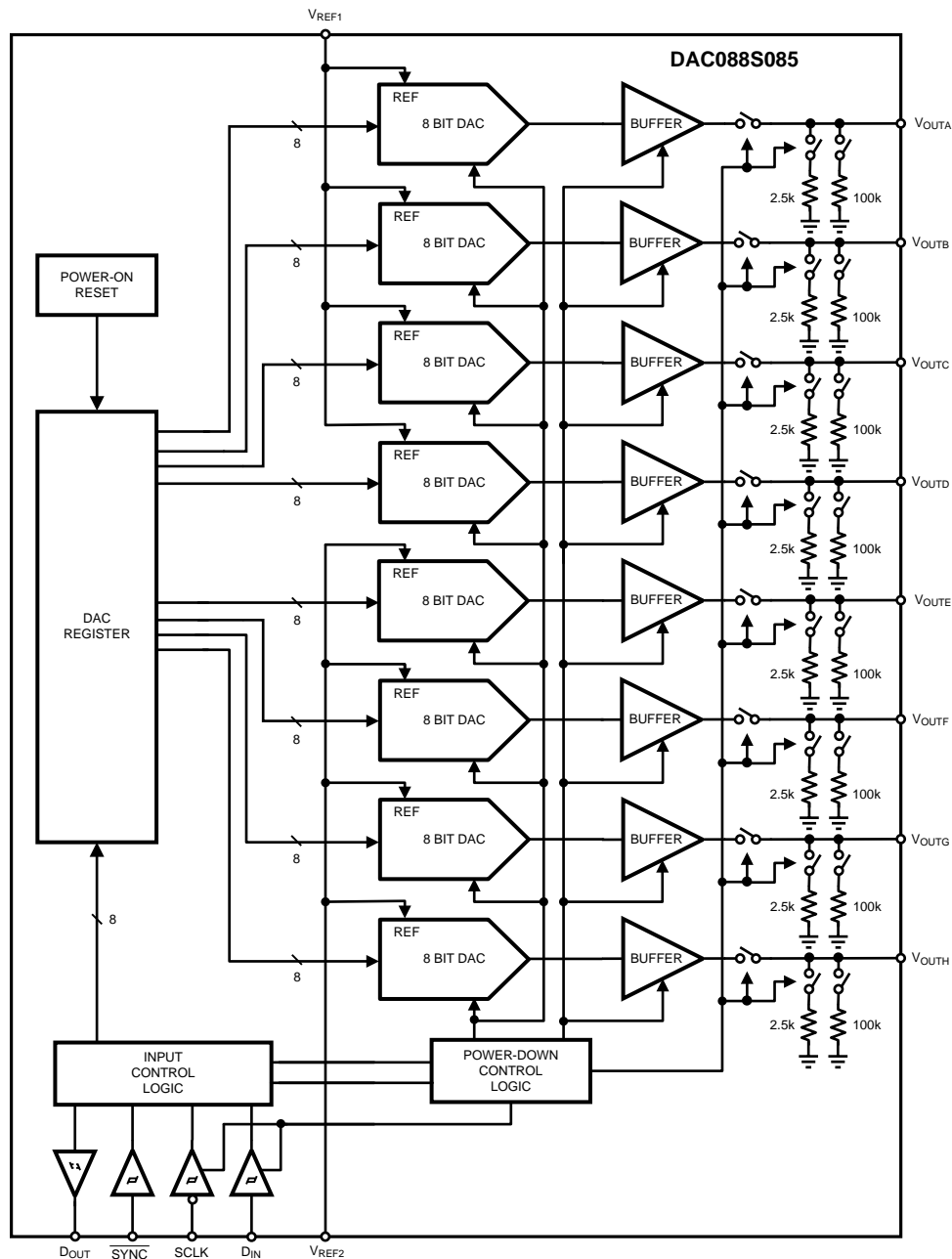

### 8.3 Feature Description

#### 8.3.1 DAC Architecture

The DAC088S085 is fabricated on a CMOS process with an architecture that consists of switches and resistor strings that are followed by an output buffer. The reference voltages are externally applied at  $V_{REF1}$  for DAC channels A through D and  $V_{REF2}$  for DAC channels E through H.

For simplicity, a single resistor string is shown in Figure 27. This string consists of 256 equal valued resistors with a switch at each junction of two resistors, plus a switch-to-ground. The code loaded into the DAC register determines which switch is closed, connecting the proper node to the amplifier. The input coding is straight binary with an ideal output voltage of:

$$V_{OUTA,B,C,D} = V_{REF1} \times (D / 256) \tag{1}$$

$$V_{OUTE,F,G,H} = V_{REF2} \times (D / 256)$$

where

- D is the decimal equivalent of the binary code that is loaded into the DAC register. (2)

D can take on any value between 0 and 255. This configuration ensures that the DAC is monotonic.

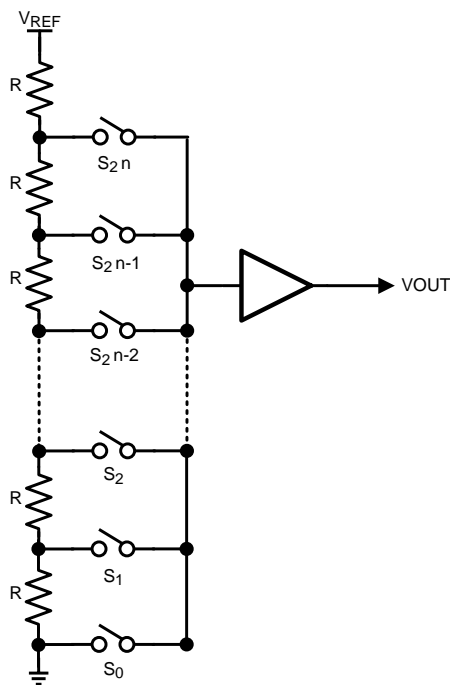

Figure 27. DAC Resistor String

Because all eight DAC channels of the DAC088S085 can be controlled independently, each channel consists of a DAC register and a 8-bit DAC. Figure 28 is a simple block diagram of an individual channel in the DAC088S085. Depending on the mode of operation, data written into a DAC register causes the 8-bit DAC output to be updated or an additional command is required to update the DAC output. Further description of the modes of operation can be found in [Serial Interface](#).

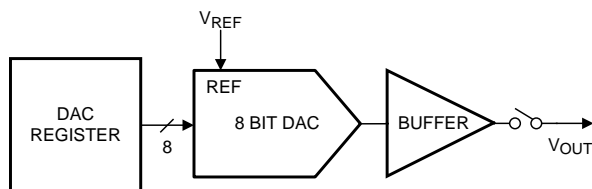

Figure 28. Single-Channel Block Diagram

## Feature Description (continued)

### 8.3.2 Output Amplifiers

The output amplifiers are rail-to-rail, providing an output voltage range of 0 V to  $V_A$  when the reference is  $V_A$ . All amplifiers, even rail-to-rail types, exhibit a loss of linearity as the output approaches the supply rails (0 V and  $V_A$ , in this case). For this reason, linearity is specified over less than the full output range of the DAC. However, if the reference is less than  $V_A$ , there is only a loss in linearity in the lowest codes.

The output amplifiers are capable of driving a load of 2 k $\Omega$  in parallel with 1500 pF to ground or to  $V_A$ . The zero-code and full-scale outputs for given load currents are available in [Electrical Characteristics](#).

### 8.3.3 Reference Voltage

The DAC088S085 uses dual external references,  $V_{REF1}$  and  $V_{REF2}$ , that are shared by channels A, B, C, D and channels E, F, G, H respectively. The reference pins are not buffered and have an input impedance of 30 k $\Omega$ . TI recommends that  $V_{REF1}$  and  $V_{REF2}$  be driven by voltage sources with low output impedance. The reference voltage range is 0.5 V to  $V_A$ , providing the widest possible output dynamic range.

## 8.4 Device Functional Modes

### 8.4.1 Power-On Reset

The power-on reset circuit controls the output voltages of the eight DACs during power up. Upon application of power, the DAC registers are filled with zeros and the output voltages are set to 0 V. The outputs remain at 0 V until a valid write sequence is made.

### 8.4.2 Power-Down Modes

The DAC088S085 has three power-down modes where different output terminations can be selected (see [Table 1](#)). With all channels powered down, the supply current drops to 0.1  $\mu$ A at 3 V and 0.2  $\mu$ A at 5 V. By selecting the channels to be powered down in DB[7:0] with a 1, individual channels can be powered down separately or multiple channels can be powered down simultaneously. The three different output terminations include high output impedance, 100 k $\Omega$  to GND, and 2.5 k $\Omega$  to GND.

The output amplifiers, resistor strings, and other linear circuitry are all shut down in any of the power-down modes. The bias generator, however, is only shut down if all the channels are placed in power down mode. The contents of the DAC registers are unaffected when in power down. Therefore, each DAC register maintains its value before the DAC088S085 being powered down unless it is changed during the write sequence which instructed it to recover from power down. Minimum power consumption is achieved in the power-down mode with SYNC idled high,  $D_{IN}$  idled low, and SCLK disabled. The time to exit power-down (Wake-Up Time) is typically 3  $\mu$ s at 3 V and 20  $\mu$ s at 5 V.

**Table 1. Power-Down Modes**

DB[15:12]	DB[11:8]	7	6	5	4	3	2	1	0	OUTPUT IMPEDANCE
1 1 0 1	X X X X	H	G	F	E	D	C	B	A	High-Z outputs
1 1 1 0	X X X X	H	G	F	E	D	C	B	A	100-k $\Omega$ outputs
1 1 1 1	X X X X	H	G	F	E	D	C	B	A	2.5-k $\Omega$ outputs

## 8.5 Programming

### 8.5.1 Serial Interface

The three-wire interface is compatible with SPI, QSPI, and MICROWIRE, as well as most DSPs and operates at clock rates up to 40 MHz. A valid serial frame contains 16 falling edges of SCLK. See Figure 1 for information on a write sequence.

A write sequence begins by bringing the  $\overline{\text{SYNC}}$  line low. Once  $\overline{\text{SYNC}}$  is low, the data on the  $\text{D}_{\text{IN}}$  line is clocked into the 16-bit serial input register on the falling edges of SCLK. To avoid mis-clocking data into the shift register, it is critical that  $\overline{\text{SYNC}}$  not be brought low on a falling edge of SCLK (see minimum and maximum setup times for  $\overline{\text{SYNC}}$  in Figure 1 and Figure 29). On the 16th falling edge of SCLK, the last data bit is clocked into the register. The write sequence is concluded by bringing the  $\overline{\text{SYNC}}$  line high. Once  $\overline{\text{SYNC}}$  is high, the programmed function (a change in the DAC channel address, mode of operation or register contents) is executed. To avoid mis-clocking data into the shift register, it is critical that  $\overline{\text{SYNC}}$  be brought high between the 16th and 17th falling edges of SCLK (see minimum and maximum hold times for  $\overline{\text{SYNC}}$  in Figure 1 and Figure 29).

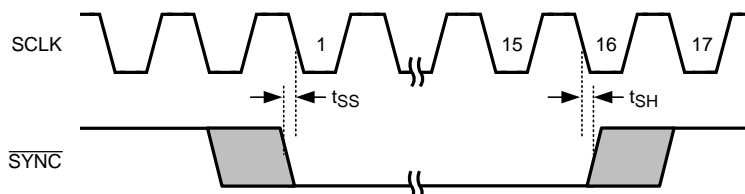

Figure 29.  $\overline{\text{CS}}$  Setup and Hold Times

If  $\overline{\text{SYNC}}$  is brought high before the 15th falling edge of SCLK, the write sequence is aborted and the data that has been shifted into the input register is discarded. If  $\overline{\text{SYNC}}$  is held low beyond the 17th falling edge of SCLK, the serial data presented at  $\text{D}_{\text{IN}}$  begins to be output on  $\text{D}_{\text{OUT}}$ . More information on this mode of operation can be found in *Daisy Chain Operation*. In either case,  $\overline{\text{SYNC}}$  must be brought high for the minimum specified time before the next write sequence is initiated with a falling edge of  $\overline{\text{SYNC}}$ .

Because the  $\text{D}_{\text{IN}}$  buffer draws more current when it is high, it must be idled low between write sequences to minimize power consumption. On the other hand,  $\overline{\text{SYNC}}$  must be idled high to avoid the activation of daisy chain operation where  $\text{D}_{\text{OUT}}$  is active.

### 8.5.2 Daisy Chain Operation

Daisy chain operation allows communication with any number of DAC088S085s using a single serial interface. As long as the correct number of data bits are input in a write sequence (multiple of sixteen bits), a rising edge of  $\overline{\text{SYNC}}$  properly updates all DACs in the system.

To support multiple devices in a daisy chain configuration, SCLK and  $\overline{\text{SYNC}}$  are shared across all DAC088S085s and  $\text{D}_{\text{OUT}}$  of the first DAC in the chain is connected to  $\text{D}_{\text{IN}}$  of the second. Figure 30 shows three DAC088S085s connected in daisy chain fashion. Similar to a single-channel write sequence, the conversion for a daisy chain operation begins on a falling edge of  $\overline{\text{SYNC}}$  and ends on a rising edge of  $\overline{\text{SYNC}}$ . A valid write sequence for  $n$  devices in a chain requires  $n$  times 16 falling edges to shift the entire input data stream through the chain. Daisy chain operation is specified for a maximum SCLK speed of 30 MHz.

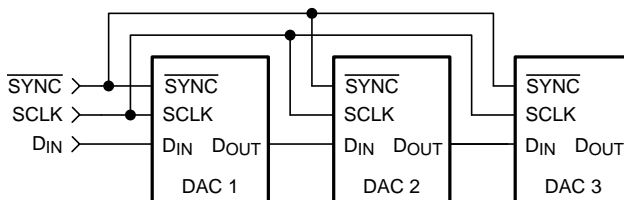
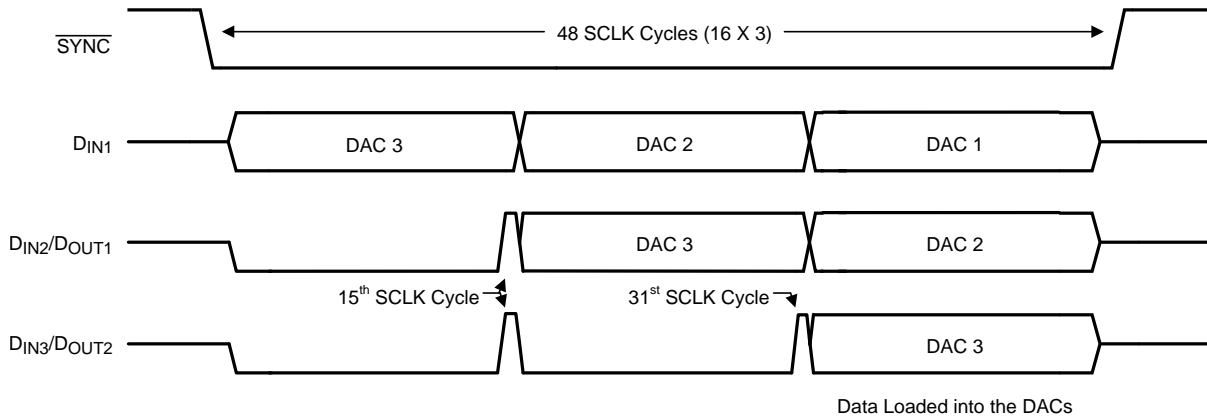

Figure 30. Daisy Chain Configuration

## Programming (continued)

The serial data output pin,  $D_{OUT}$ , is available on the DAC088S085 to allow daisy-chaining of multiple DAC088S085 devices in a system. In a write sequence,  $D_{OUT}$  remains low for the first fourteen falling edges of SCLK before going high on the fifteenth falling edge. Subsequently, the next sixteen falling edges of SCLK outputs the first sixteen data bits entered into  $D_{IN}$ . Figure 31 shows the timing of three DAC088S085s in Figure 30. In this instance, It takes forty-eight falling edges of SCLK followed by a rising edge of SYNC to load all three DAC088S085s with the appropriate register data. On the rising edge of SYNC, the programmed function is executed in each DAC088S085 simultaneously.



**Figure 31. Daisy Chain Timing Diagram**

### 8.5.3 Serial Input Register

The DAC088S085 has two modes of operation plus a few special command operations. The two modes of operation are Write Register Mode (WRM) and Write Through Mode (WTM). For the rest of this document, these modes is referred to as WRM and WTM. The special command operations are separate from WRM and WTM because they can be called upon regardless of the current mode of operation. The mode of operation is controlled by the first four bits of the control register, DB15 through DB12. See Table 2 for a detailed summary.

**Table 2. Write Register and Write Through Modes**

DB[15:12]	DB[11:0]	DESCRIPTION OF MODE
1 0 0 0	X X X X X X X X X X X X	WRM: The registers of each DAC Channel can be written to without causing their outputs to change.
1 0 0 1	X X X X X X X X X X X X	WTM: Writing data to a channel's register causes the DAC output to change.

When the DAC088S085 first powers up, the DAC is in WRM. In WRM, the registers of each individual DAC channel can be written to without causing the DAC outputs to be updated. This is accomplished by setting DB15 to 0, specifying the DAC register to be written to in DB[14:12], and entering the new DAC register setting in DB[11:0] (see Table 3). The DAC088S085 remains in WRM until the mode of operation is changed to WTM. The mode of operation is changed from WRM to WTM by setting DB[15:12] to 1001. Once in WTM, writing data to a DAC channel's register causes the DAC's output to be updated as well. Changing a DAC channel's register in WTM is accomplished in the same manner as it is done in WRM. However, in WTM the DAC's register and output are updated at the completion of the command (see Table 3). Similarly, the DAC088S085 remains in WTM until the mode of operation is changed to WRM by setting DB[15:12] to 1000.

**Table 3. Commands Impacted by WRM and WTM**

DB15	DB[14:12]	DB[11:0]	DESCRIPTION OF MODE
0	0 0 0	D11 D10 ... D4 X X X X	WRM: D[11:0] written to ChA's data register only WTM: ChA's output is updated by data in D[11:0]
0	0 0 1	D11 D10 ... D4 X X X X	WRM: D[11:0] written to ChB's data register only WTM: ChB's output is updated by data in D[11:0]
0	0 1 0	D11 D10 ... D4 X X X X	WRM: D[11:0] written to ChC's data register only WTM: ChC's output is updated by data in D[11:0]
0	0 1 1	D11 D10 ... D4 X X X X	WRM: D[11:0] written to ChD's data register only WTM: ChD's output is updated by data in D[11:0]
0	1 0 0	D11 D10 ... D4 X X X X	WRM: D[11:0] written to ChE's data register only WTM: ChE's output is updated by data in D[11:0]
0	1 0 1	D11 D10 ... D4 X X X X	WRM: D[11:0] written to ChF's data register only WTM: ChF's output is updated by data in D[11:0]
0	1 1 0	D11 D10 ... D4 X X X X	WRM: D[11:0] written to ChG's data register only WTM: ChG's output is updated by data in D[11:0]
0	1 1 1	D11 D10 ... D4 X X X X	WRM: D[11:0] written to ChH's data register only WTM: ChH's output is updated by data in D[11:0]

As mentioned previously, the special command operations can be exercised at any time regardless of the mode of operation. There are three special command operations. The first command is exercised by setting data bits DB[15:12] to 1010. This allows a user to update multiple DAC outputs simultaneously to the values currently loaded in their respective control registers. This command is valuable if the user wants each DAC output to be at a different output voltage but still have all the DAC outputs change to their appropriate values simultaneously (see [Table 4](#)).

The second special command allows the user to alter the DAC output of channel A with a single write frame. This command is exercised by setting data bits DB[15:12] to 1011 and data bits DB[11:0] to the desired control register value. It also has the added benefit of causing the DAC outputs of the other channels to update to their current control register values as well. A user may choose to exercise this command to save a write sequence. For example, the user may wish to update several DAC outputs simultaneously, including channel A. To accomplish this task in the minimum number of write frames, the user would alter the control register values of all the DAC channels except channel A while operating in WRM. The last write frame would be used to exercise the special command *Channel A Write Mode*. In addition to updating channel A's control register and output to a new value, all of the other channels would be updated as well. At the end of this sequence of write frames, the DAC088S085 would still be operating in WRM (see [Table 4](#)).

The third special command allows the user to set all the DAC control registers and outputs to the same level. This command is commonly referred to as *broadcast* mode because the same data bits are being broadcast to all of the channels simultaneously. This command is exercised by setting data bits DB[15:12] to 1100 and data bits DB[7:0] to the value that the user wishes to broadcast to all the DAC control registers. Once the command is exercised, each DAC output is updated by the new control register value. This command is frequently used to set all the DAC outputs to some known voltage such as 0 V,  $V_{REF} / 2$ , or Full Scale. A summary of the commands can be found in [Table 4](#).

**Table 4. Special Command Operations**

DB[15:12]	DB[11:0]	DESCRIPTION OF MODE
1 0 1 0	X X X X H G F E D C B A	Update Select: The DAC outputs of the channels selected with a 1 in DB[7:0] are updated simultaneously to the values in their respective control registers.
1 0 1 1	D11 D10 ... D4 X X X X	Channel A Write: the control register of Channel A and DAC output are updated to the data in DB[11:0]. The outputs of the other seven channels are also updated according to their respective control register values.
1 1 0 0	D11 D10 ... D4 X X X X	Broadcast: The data in DB[11:0] is written to all channels' control register and DAC output simultaneously.

## 9 Application and Implementation

### NOTE

Information in the following applications sections is not part of the TI component specification, and TI does not warrant its accuracy or completeness. TI's customers are responsible for determining suitability of components for their purposes. Customers should validate and test their design implementation to confirm system functionality.

### 9.1 Application Information

#### 9.1.1 Examples Programming the DAC088S085

This section presents the step-by-step instructions for programming the serial input register.

##### 9.1.1.1 Updating DAC Outputs Simultaneously

When the DAC088S085 is first powered on, the DAC is operating in Write Register Mode (WRM). Operating in WRM allows the user to program the registers of multiple DAC channels without causing the DAC outputs to be updated. As an example, here are the steps for setting Channel A to a full scale output, Channel B to three-quarters full scale, Channel C to half-scale, Channel D to one-quarter full scale and having all the DAC outputs update simultaneously.

As stated previously, the DAC088S085 powers up in WRM. If the device was previously operating in Write Through Mode (WTM), an extra step to set the DAC into WRM would be required. First, the DAC registers need to be programmed to the desired values. To set Channel A to an output of full scale, write 0FF0 to the control register. This updates the data register for Channel A without updating the output of Channel A. Second, set Channel B to an output of three-quarters full scale by writing 1C00 to the control register. This updates the data register for Channel B. Once again, the output of Channel B and Channel A is not updated because the DAC is operating in WRM. Third, set Channel C to half scale by writing 2800 to the control register. Fourth, set Channel D to one-quarter full scale by writing 3400 to the control register. Finally, update all four DAC channels simultaneously by writing A00F to the control register. This procedure allows the user to update four channels simultaneously with five steps.

Because Channel A was one of the DACs to be updated, one command step could have been saved by writing to Channel A last. This is accomplished by writing to Channel B, C, and D first and using the special command Channel A Write to update the DAC register and output of Channel A. This special command has the added benefit of updating all DAC outputs while updating Channel A. With this sequence of commands, the user was able to update four channels simultaneously with four steps. A summary of this command can be found in [Table 4](#).

##### 9.1.1.2 Updating DAC Outputs Independently

If the DAC088S085 is currently operating in WRM, change the mode of operation to WTM by writing 9XXX to the control register. Once the DAC is operating in WTM, any DAC channel can be updated in one step. For example, if a design required Channel G to be set to half scale, the user can write 6800 to the control register and the data register of Channel G and DAC output is updated. Similarly, if the output of Channel F needed to be set to full scale, 5FF0 would need to be written to the control register. Channel A is the only channel that has a special command that allows its DAC output to be updated in one command regardless of the mode of operation. Setting the DAC output of Channel A to full scale could be accomplished in one step by writing BFFF to the control register.

## Application Information (continued)

### 9.1.2 Bipolar Operation

The DAC088S085 is designed for single-supply operation and thus has a unipolar output. However, a bipolar output may be achieved with the circuit in Figure 32. This circuit provides an output voltage range of  $\pm 5$  V. A rail-to-rail amplifier must be used if the amplifier supplies are limited to  $\pm 5$  V.

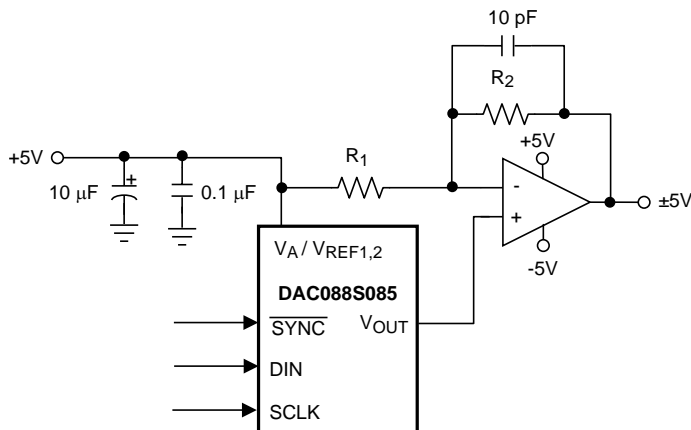

Figure 32. Bipolar Operation

The output voltage of this circuit for any code is found to be

$$V_O = V_A \times (D / 256) \times (R_1 + R_2) / R_1 - V_A \times R_2 / R_1$$

where

- D is the input code in decimal form. (3)

With  $V_A = 5$  V and  $R_1 = R_2$ ,

$$V_O = (10 \times D / 256) - 5$$
 (4)

A list of rail-to-rail amplifiers suitable for this application are indicated in Table 5.

Table 5. Some Rail-to-Rail Amplifiers

AMP	PKGS	TYP $V_{OS}$	TYP $I_{SUPPLY}$
LMP7701	SOT-23	$\pm 37$ $\mu$ V	0.79 mA
LMV841	SOT-23	$-17$ $\mu$ V	1.11 mA
LMC7111	SOT-23	900 $\mu$ V	25 $\mu$ A
LM7301	SOT-23	30 $\mu$ V	620 $\mu$ A
LM8261	SOT-23	700 $\mu$ V	1 mA

### 9.1.3 Variable Current Source Output

The DAC088S085 is a voltage output DAC but can be easily converted to a current output with the addition of an operational amplifier. In Figure 33, one of the channels of the DAC088S085 is converted to a variable current source capable of sourcing up to 40 mA.

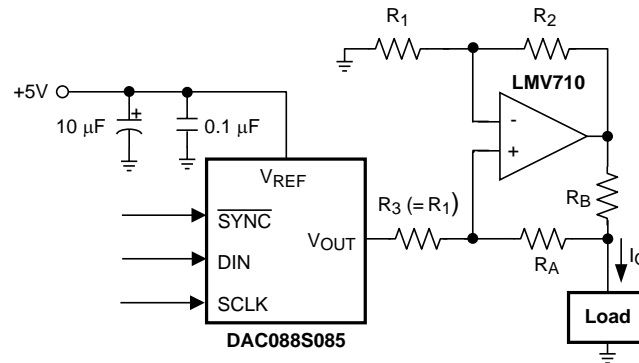

**Figure 33. Variable Current Source**

The output current of this circuit ( $I_O$ ) for any DAC code is found to be

$$I_O = (V_{REF} \times (D / 256) \times (R_2)) / (R_1 \times R_B)$$

where

- D is the input code in decimal form
- $R_2 = R_A + R_B$

(5)

### 9.1.4 DSP and Microprocessor Interfacing

Interfacing the DAC088S085 to microprocessors and DSPs is quite simple. The following guidelines are offered to hasten the design process.

#### 9.1.4.1 ADSP-2101 and ADSP2103 Interfacing

Figure 34 shows a serial interface between the DAC088S085 and the ADSP-2101 or ADSP2103. The DSP must be set to operate in the SPORT Transmit Alternate Framing Mode. It is programmed through the SPORT control register and must be configured for Internal Clock Operation, Active Low Framing and 16-bit Word Length. Transmission is started by writing a word to the Tx register after the SPORT mode has been enabled.

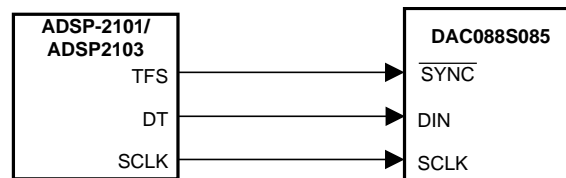

**Figure 34. ADSP-2101 and ADSP-2103 Interface**

### 9.1.4.2 80C51 and 80L51 Interface

A serial interface between the DAC088S085 and the 80C51 or 80L51 microcontroller is shown in Figure 35. The SYNC signal comes from a bit-programmable pin on the microcontroller. The example shown here uses port line P3.3. This line is taken low when data is transmitted to the DAC088S085. Because the 80x51 transmits 8-bit bytes, only eight falling clock edges occur in the transmit cycle. To load data into the DAC, the P3.3 line must be left low after the first eight bits are transmitted. A second write cycle is initiated to transmit the second byte of data, after which port line P3.3 is brought high. The 80x51 transmit routine must recognize that the 80x51 transmits data with the LSB first while the DAC088S085 requires data with the MSB first.

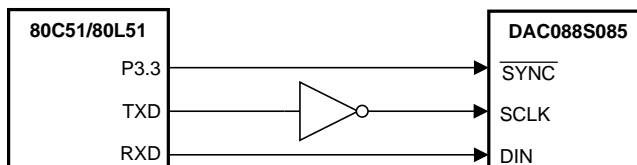

Figure 35. 80C51 and 80L51 Interface

### 9.1.4.3 68HC11 Interface

A serial interface between the DAC088S085 and the 68HC11 microcontroller is shown in Figure 36. The SYNC line of the DAC088S085 is driven from a port line (PC7 in the figure), similar to the 80C51 and 80L51.

The 68HC11 must be configured with its CPOL bit as a zero and its CPHA bit as a one. This configuration causes data on the MOSI output to be valid on the falling edge of SCLK. PC7 is taken low to transmit data to the DAC. The 68HC11 transmits data in 8-bit bytes with eight falling clock edges. Data is transmitted with the MSB first. PC7 must remain low after the first eight bits are transferred. A second write cycle is initiated to transmit the second byte of data to the DAC, after which PC7 must be raised to end the write sequence.

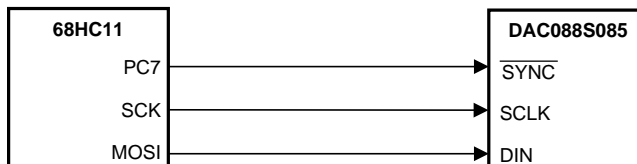

Figure 36. 68HC11 Interface

### 9.1.4.4 Microwire Interface

Figure 37 shows an interface between a Microwire compatible device and the DAC088S085. Data is clocked out on the rising edges of the SK signal. As a result, the SK of the Microwire device must be inverted before driving the SCLK of the DAC088S085.

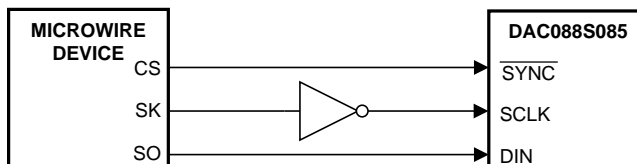
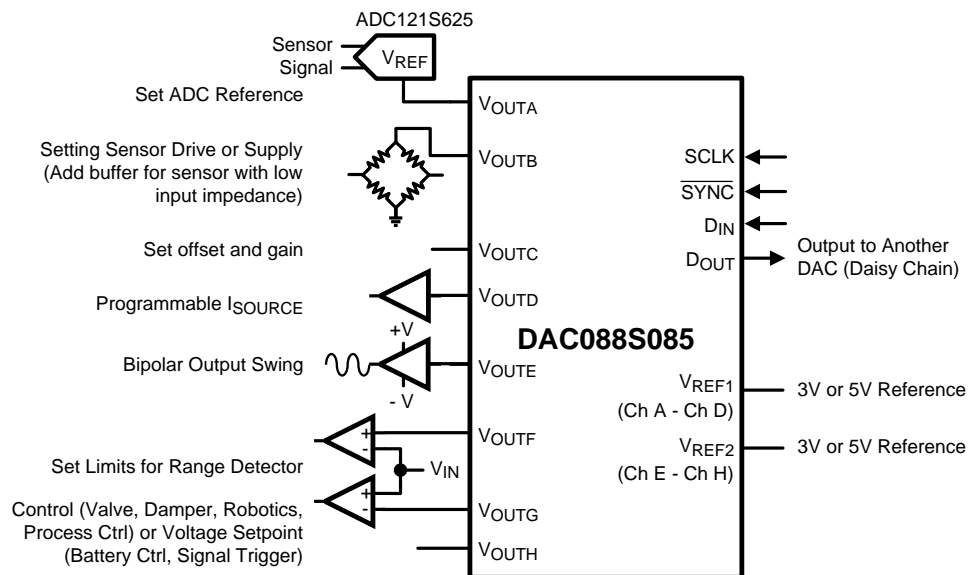

Figure 37. Microwire Interface

### 9.1.5 Industrial Application

Figure 38 shows the DAC088S085 controlling several different circuits in an industrial setting. Channel A is shown providing the reference voltage to the ADC081S625, one of Texas Instruments' general-purpose Analog-to-Digital Converters (ADCs). The reference for the ADC121S625 may be set to any voltage from 0.2 V to 5.5 V, providing the widest dynamic range possible. Typically, the ADC121S625 is monitoring a sensor and would benefit from the reference voltage of ADC being adjustable. Channel B is providing the drive or supply voltage for a sensor. By having the sensor supply voltage adjustable, the output of the sensor can be optimized to the input level of the ADC monitoring it. Channel C is defined to adjust the offset or gain of an amplifier stage in the system. Channel D is configured with an operational amplifier to provide an adjustable current source. Being able to convert one of the eight channels of the DAC088S085 to a current output eliminates the need for a separate current output DAC to be added to the circuit. Channel E, in conjunction with an operational amplifier, provides a bipolar output swing for devices requiring control voltages that are centered around ground. Channel F and G are used to set the upper and lower limits for a range detector. Channel H is reserved for providing voltage control or acting as a voltage setpoint.



**Figure 38. Industrial Application**

## 9.2 Typical Applications

The following figures are examples of the DAC088S085 in typical application circuits. These circuits are basic and generally requires modification for specific circumstances.

### 9.2.1 ADC Reference

Figure 39 shows Channel A of the DAC088S085 providing the drive or supply voltage for a bridge sensor. By having the sensor supply voltage adjustable, the output of the sensor can be optimized to the input level of the ADC monitoring it.

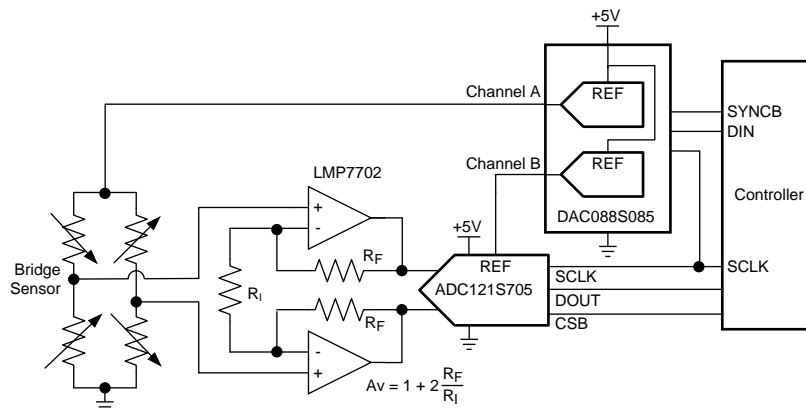

Figure 39. Driving an ADC Reference

#### 9.2.1.1 Design Requirements

For this design example, use these requirements:

- Provide drive for a bridge sensor that is adjustable through SPI from an MCU.
- Provide reference voltage for an ADC that is adjustable through SPI from an MCU.
- Use a single 5 V supply.
- Use ratiometric design for the bridge and ADC reference.

#### 9.2.1.2 Detailed Design Procedure

The output of the sensor is amplified by a fixed gain amplifier stage with a differential gain of  $1 + 2 \times (R_F / R_I)$ . The advantage of this amplifier configuration is the high input impedance seen by the output of the bridge sensor. The disadvantage is the poor common-mode rejection ratio (CMRR). The common-mode voltage ( $V_{CM}$ ) of the bridge sensor is half of the DAC output of Channel A. The  $V_{CM}$  is amplified by a gain of 1 V/V by the amplifier stage and thus becomes the bias voltage for the input of the ADC121S705. Channel B of the DAC088S085 is providing the reference voltage to the ADC121S705. The reference for the ADC121S705 may be set to any voltage from 1 V to 5 V, providing the widest dynamic range possible.

The reference voltage for Channel A and B is powered by an external 5 V power supply. Because the 5 V supply is common to the sensor supply voltage and the reference voltage of the ADC, fluctuations in the value of the 5-V supply has a minimal effect on the digital output code of the ADC. This type of configuration is often referred to as a *Ratio-metric* design. For example, an increase of 5% to the 5 V supply causes the sensor supply voltage to increase by 5%. This causes the gain or sensitivity of the sensor to increase by 5%. The gain of the amplifier stage is unaffected by the change in supply voltage. The ADC121S705 on the other hand, also experiences a 5% increase to its reference voltage. This causes the size of the least significant bit (LSB) of the ADC to increase by 5%. As a result of the sensor's gain increasing by 5% and the LSB size of the ADC increasing by the same 5%, there is no net effect on the circuit's performance. It is assumed that the amplifier gain is set low enough to allow for a 5% increase in the sensor output. Otherwise, the increase in the sensor output level may cause the output of the amplifiers to clip.

## Typical Applications (continued)

### 9.2.1.3 Application Curve

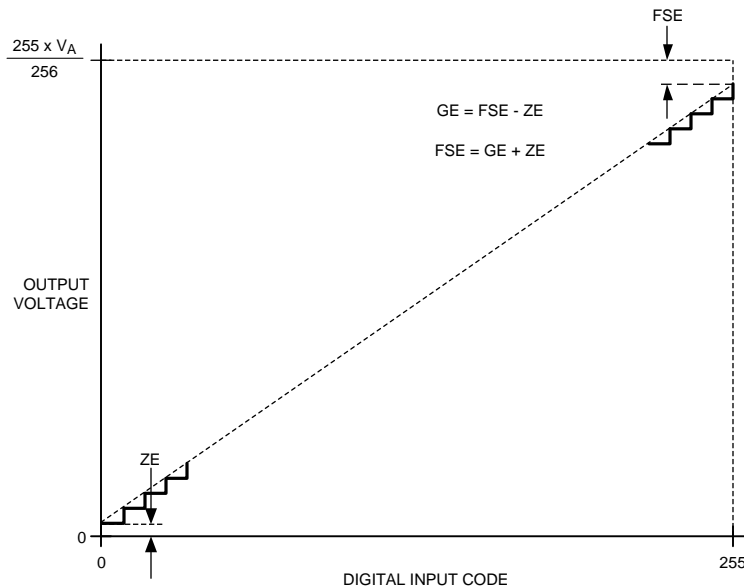

Figure 40. I/O Transfer Characteristic

### 9.2.2 Programmable Attenuator

Figure 41 shows one of the channels of the DAC088S085 being used as a single-quadrant multiplier.

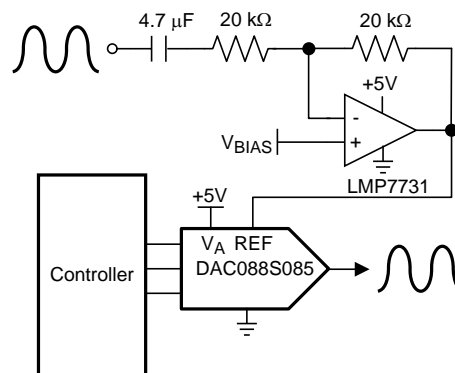

Figure 41. Programmable Attenuator Diagram

#### 9.2.2.1 Design Requirements

For this design example, use these requirements:

- Use a single 5 V supply.
- Use the SPI interface to control the amount of attenuation of a signal.
- Do not add any noise to the signal.

#### 9.2.2.2 Detailed Design Procedure

In this configuration, an AC or DC signal can be driven into one of the reference pins. The SPI interface of the DAC can be used to digitally attenuate the signal to any level from 0 dB (full scale) to 0 V. This is accomplished without adding any noticeable level of noise to the signal. An amplifier stage is shown in Figure 41 as a reference for applications where the input signal requires amplification. Notice how the AC signal in this application is AC-coupled to the amplifier before being amplified. A separate bias voltage is used to set the common-mode voltage for the DAC088S085's reference input to  $V_A / 2$ , allowing the largest possible input swing. The multiplying bandwidth of  $V_{REF1,2}$  is 360 kHz with a  $V_{CM}$  of 2.5 V and a peak-to-peak signal swing of 2 V.

## Typical Applications (continued)

### 9.2.2.3 Application Curve

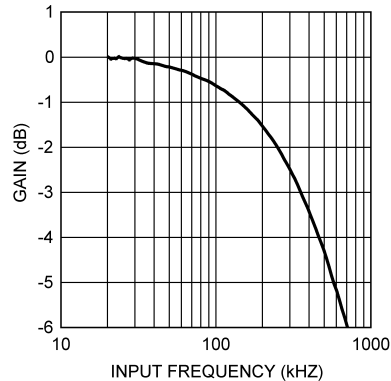

Figure 42. Multiplier Bandwidth

## 9.3 Do's and Don'ts

- Install bypass capacitors next to the  $V_A$ ,  $V_{REF1}$ , and  $V_{REF2}$  pins.
- The reference inputs must be kept stable and noise free. Besides installing bypass capacitors close to the pins, the traces that have the reference voltages must be kept away from noisy traces.
- Keep analog and digital traces away from each other. If they need to cross, have the traces cross at a 90° angle.

## 10 Power Supply Recommendations

### 10.1 Using References as Power Supplies

While the simplicity of the DAC088S085 implies ease of use, it is important to recognize that the path from the reference input ( $V_{REF1,2}$ ) to the DAC outputs has zero Power Supply Rejection Ratio (PSRR). Therefore, it is necessary to provide a noise-free supply voltage to  $V_{REF1,2}$ . To use the full dynamic range of the DAC088S085, the supply pin ( $V_A$ ) and  $V_{REF1,2}$  can be connected together and share the same supply voltage. Because the DAC088S085 consumes very little power, a reference source may be used as the reference input or the supply voltage. The advantages of using a reference source over a voltage regulator are accuracy and stability. Some low noise regulators can also be used. Listed below are a few reference and power supply options for the DAC088S085.

#### 10.1.1 LM4132

The LM4132, with its  $\pm 0.05\%$  accuracy over temperature, is a good choice as a reference source for the DAC088S085. The 4.096 V version is useful if a 0 V to 4.09 V output range is desirable. Bypassing the LM4132 voltage input pin with a 4.7- $\mu\text{F}$  capacitor and the voltage output pin with a 4.7- $\mu\text{F}$  capacitor improves stability and reduce output noise. The LM4132 comes in a space-saving, 5-pin SOT-23 package.

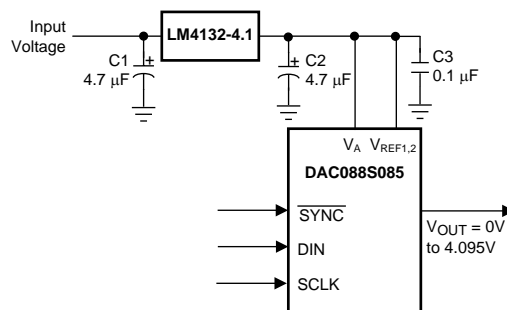

Figure 43. The LM4132 as a Power Supply

## Using References as Power Supplies (continued)

### 10.1.2 LM4050

Available with accuracy of  $\pm 0.1\%$ , the LM4050 shunt reference is also a good choice as a reference for the DAC088S085. It is available in 4.096 V and 5 V versions and comes in a space-saving, 3-pin SOT-23 package.

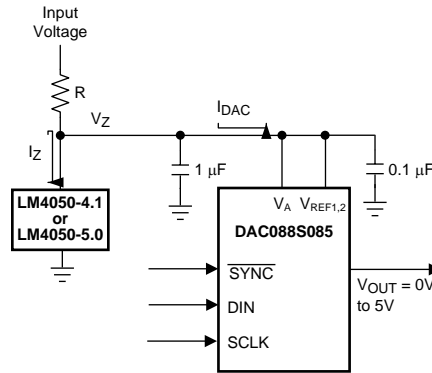

Figure 44. The LM4050 as a Power Supply

The minimum resistor value in the circuit of Figure 44 must be chosen such that the maximum current through the LM4050 does not exceed its 15-mA rating. The conditions for maximum current include the input voltage at its maximum, the LM4050 voltage at its minimum, and the DAC088S085 drawing zero current. The maximum resistor value must allow the LM4050 to draw more than its minimum current for regulation plus the maximum DAC088S085 current in full operation. The conditions for minimum current include the input voltage at its minimum, the LM4050 voltage at its maximum, the resistor value at its maximum due to tolerance, and the DAC088S085 draws its maximum current. These conditions can be summarized as:

$$R(\min) = (V_{IN}(\max) - V_Z(\min)) / I_Z(\max) \quad (6)$$

and

$$R(\max) = (V_{IN}(\min) - V_Z(\max)) / (I_{DAC}(\max) + I_Z(\min))$$

where

- $V_Z(\min)$  and  $V_Z(\max)$  are the nominal LM4050 output voltages  $\pm$  the LM4050 output tolerance over temperature
  - $I_Z(\max)$  is the maximum allowable current through the LM4050,  $I_Z(\min)$  is the minimum current required by the LM4050 for proper regulation
  - $I_{DAC}(\max)$  is the maximum DAC088S085 supply current.
- (7)

### 10.1.3 LP3985

The LP3985 is a low-noise, ultra-low dropout voltage regulator with a  $\pm 3\%$  accuracy over temperature. It is a good choice for applications that do not require a precision reference for the DAC088S085. It comes in 3 V, 3.3 V, and 5 V versions, among others, and sports a low 30- $\mu$ V noise specification at low frequencies. Because low frequency noise is relatively difficult to filter, this specification could be important for some applications. The LP3985 comes in a space-saving, 5-pin SOT-23 and 5-bump DSBGA packages.

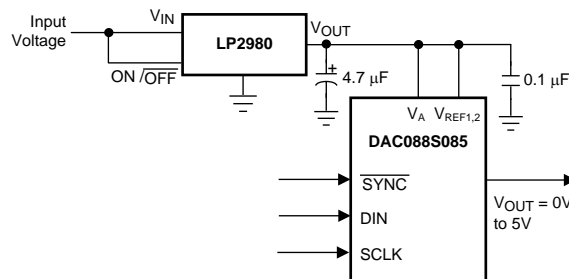

Figure 45. Using the LP3985 Regulator

## Using References as Power Supplies (continued)

An input capacitance of 1  $\mu\text{F}$  without any ESR requirement is required at the LP3985 input, while a 1- $\mu\text{F}$  ceramic capacitor with an ESR requirement of 5 m $\Omega$  to 500 m $\Omega$  is required at the output. Careful interpretation and understanding of the capacitor specification is required to ensure correct device operation.

### 10.1.4 LP2980

The LP2980 is an ultra-low dropout regulator with a  $\pm 0.5\%$  or  $\pm 1\%$  accuracy over temperature, depending upon grade. It is available in 3 V, 3.3 V, and 5 V versions, among others.

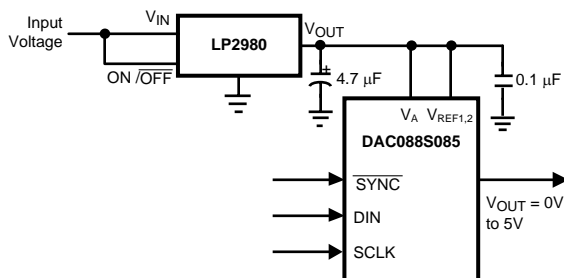

**Figure 46. Using the LP2980 Regulator**

Like any low dropout regulator, the LP2980 requires an output capacitor for loop stability. This output capacitor must be at least 1  $\mu\text{F}$  over temperature, but values of 2.2  $\mu\text{F}$  or more provides even better performance. The ESR of this capacitor must be within the range specified in the LP2980 data sheet. Surface-mount solid tantalum capacitors offer a good combination of small size and low ESR. Ceramic capacitors are attractive due to their small size but generally have ESR values that are too low for use with the LP2980. Aluminum electrolytic capacitors are typically not a good choice due to their large size and high ESR values at low temperatures.

## 11 Layout

### 11.1 Layout Guidelines

For best accuracy and minimum noise, the printed-circuit board containing the DAC088S085 must have separate analog and digital areas. The areas are defined by the locations of the analog and digital power planes. Both of these planes must be located in the same board layer. A single ground plane is preferred if digital return current does not flow through the analog ground area. Frequently a single ground plane design uses a *fencing* technique to prevent the mixing of analog and digital ground current. Separate ground planes must only be used when the fencing technique is inadequate. The separate ground planes must be connected in one place, preferably near the DAC088S085. Take special care to ensure that digital signals with fast edge rates do not pass over split ground planes. They must always have a continuous return path below their traces.

For best performance, the DAC088S085 power supply must be bypassed with at least a 1- $\mu\text{F}$  and a 0.1- $\mu\text{F}$  capacitor. The 0.1- $\mu\text{F}$  capacitor must be placed right at the device supply pin. The 1- $\mu\text{F}$  or larger valued capacitor can be a tantalum capacitor while the 0.1- $\mu\text{F}$  capacitor must be a ceramic capacitor with low ESL and low ESR. If a ceramic capacitor with low ESL and low ESR is used for the 1- $\mu\text{F}$  value and it can be placed right at the supply pin, the 0.1- $\mu\text{F}$  capacitor can be eliminated. Capacitors of this nature typically span the same frequency spectrum as the 0.1- $\mu\text{F}$  capacitor and thus eliminate the need for the extra capacitor. The power supply for the DAC088S085 must only be used for analog circuits.

It is also advisable to avoid the crossover of analog and digital signals. This helps minimize the amount of noise from the transitions of the digital signals from coupling onto the sensitive analog signals such as the reference pins and the DAC outputs.

## 11.2 Layout Example

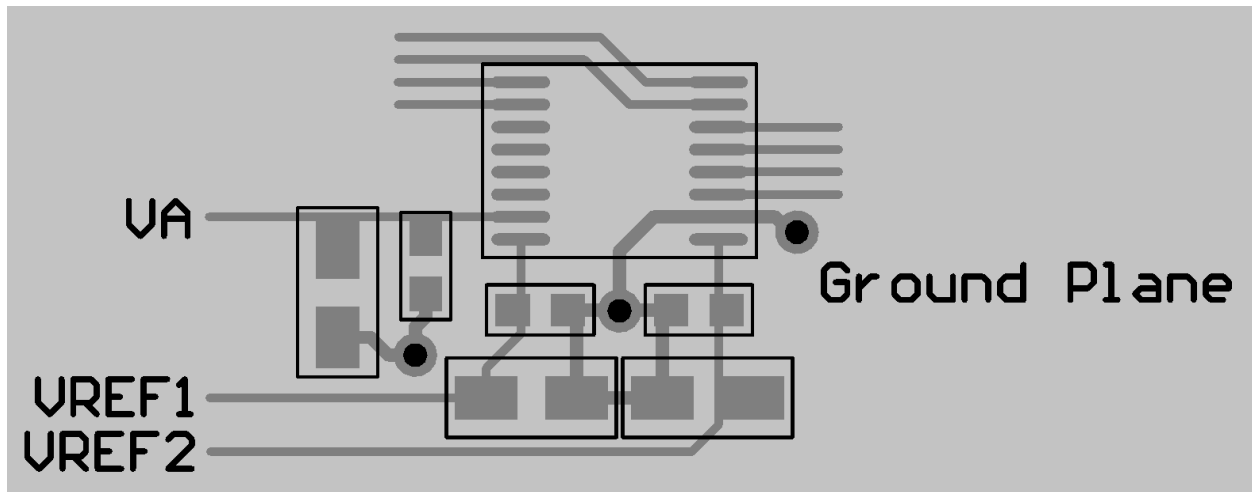

Figure 47. Typical Layout

## 12 Device and Documentation Support

### 12.1 Device Support

#### 12.1.1 Device Nomenclature

##### 12.1.1.1 Specification Definitions

**DIFFERENTIAL NON-LINEARITY (DNL)** The measure of the maximum deviation from the ideal step size of 1 LSB, which is  $V_{REF} / 256 = V_A / 256$ .

**DAC-to-DAC CROSSTALK** The glitch impulse transferred to a DAC output in response to a full-scale change in the output of another DAC.

**DIGITAL CROSSTALK** The glitch impulse transferred to a DAC output at mid-scale in response to a full-scale change in the input register of another DAC.

**DIGITAL FEEDTHROUGH** A measure of the energy injected into the analog output of the DAC from the digital inputs when the DAC outputs are not updated. It is measured with a full-scale code change on the data bus.

**FULL-SCALE ERROR** The difference between the actual output voltage with a full scale code (FFh) loaded into the DAC and the value of  $V_A \times 255 / 256$ .

**GAIN ERROR** The deviation from the ideal slope of the transfer function. It can be calculated from Zero and Full-Scale Errors as  $GE = FSE - ZE$ , where GE is Gain error, FSE is Full-Scale Error and ZE is Zero Error.

**GLITCH IMPULSE** The energy injected into the analog output when the input code to the DAC register changes. It is specified as the area of the glitch in nanovolt-seconds.

**INTEGRAL NON-LINEARITY (INL)** A measure of the deviation of each individual code from a straight line through the input to output transfer function. The deviation of any given code from this straight line is measured from the center of that code value. The end point method is used. INL for this product is specified over a limited range, per [Electrical Characteristics](#).

**LEAST SIGNIFICANT BIT (LSB)** The bit that has the smallest value or weight of all bits in a word. This value is:

$$LSB = V_{REF} / 2^n$$

where

- $V_{REF}$  is the supply voltage for this product
- $n$  is the DAC resolution in bits, which is 8 for the DAC088S085 (8)

**MAXIMUM LOAD CAPACITANCE** The maximum capacitance that can be driven by the DAC with output stability maintained.

**MONOTONICITY** The condition of being monotonic, where the DAC has an output that never decreases when the input code increases.

**MOST SIGNIFICANT BIT (MSB)** The bit that has the largest value or weight of all bits in a word. Its value is 1/2 of  $V_A$ .

**MULTIPLYING BANDWIDTH** The frequency at which the output amplitude falls 3 dB below the input sine wave on  $V_{REF1,2}$  with the DAC code at full-scale.

**NOISE SPECTRAL DENSITY** The internally generated random noise. It is measured by loading the DAC to mid-scale and measuring the noise at the output.

**POWER EFFICIENCY** The ratio of the output current to the total supply current. The output current comes from the power supply. The difference between the supply and output currents is the power consumed by the device without a load.

**SETTLING TIME** The time for the output to settle to within 1/2 LSB of the final value after the input code is updated.

## Device Support (continued)

**TOTAL HARMONIC DISTORTION PLUS NOISE (THD+N)** The ratio of the harmonics plus the noise present at the output of the DACs to the rms level of an ideal sine wave applied to  $V_{REF1,2}$  with the DAC code at mid-scale.

**WAKE-UP TIME** The time for the output to exit power-down mode. This is the time from the rising edge of  $\overline{SYNC}$  to when the output voltage deviates from the power-down voltage of 0 V.

**ZERO CODE ERROR** The output error, or voltage, present at the DAC output after a code of 00h has been entered.

## 12.2 Community Resources

The following links connect to TI community resources. Linked contents are provided "AS IS" by the respective contributors. They do not constitute TI specifications and do not necessarily reflect TI's views; see TI's [Terms of Use](#).

**TI E2E™ Online Community** *TI's Engineer-to-Engineer (E2E) Community*. Created to foster collaboration among engineers. At [e2e.ti.com](http://e2e.ti.com), you can ask questions, share knowledge, explore ideas and help solve problems with fellow engineers.

**Design Support** *TI's Design Support* Quickly find helpful E2E forums along with design support tools and contact information for technical support.

## 12.3 Trademarks

E2E is a trademark of Texas Instruments.

SPI is a trademark of Motorola, Inc..

All other trademarks are the property of their respective owners.

## 12.4 Electrostatic Discharge Caution



These devices have limited built-in ESD protection. The leads should be shorted together or the device placed in conductive foam during storage or handling to prevent electrostatic damage to the MOS gates.

## 12.5 Glossary

**SLYZ022** — *TI Glossary*.

This glossary lists and explains terms, acronyms, and definitions.

## 13 Mechanical, Packaging, and Orderable Information

The following pages include mechanical, packaging, and orderable information. This information is the most current data available for the designated devices. This data is subject to change without notice and revision of this document. For browser-based versions of this data sheet, refer to the left-hand navigation.

**PACKAGING INFORMATION**

Orderable Device	Status (1)	Package Type	Package Drawing	Pins	Package Qty	Eco Plan (2)	Lead/Ball Finish (6)	MSL Peak Temp (3)	Op Temp (°C)	Device Marking (4/5)	Samples
DAC088S085CIMT/NOPB	ACTIVE	TSSOP	PW	16	92	Green (RoHS & no Sb/Br)	CU SN	Level-1-260C-UNLIM	-40 to 125	X82C	<a href="#">Samples</a>
DAC088S085CIMTX/NOPB	ACTIVE	TSSOP	PW	16	2500	Green (RoHS & no Sb/Br)	CU SN	Level-1-260C-UNLIM	-40 to 125	X82C	<a href="#">Samples</a>
DAC088S085CISQ/NOPB	ACTIVE	WQFN	RGH	16	1000	Green (RoHS & no Sb/Br)	CU SN	Level-1-260C-UNLIM	-40 to 125	088S085	<a href="#">Samples</a>
DAC088S085CISQX/NOPB	ACTIVE	WQFN	RGH	16	4500	Green (RoHS & no Sb/Br)	CU SN	Level-1-260C-UNLIM	-40 to 125	088S085	<a href="#">Samples</a>

(1) The marketing status values are defined as follows:

**ACTIVE:** Product device recommended for new designs.

**LIFEBUY:** TI has announced that the device will be discontinued, and a lifetime-buy period is in effect.

**NRND:** Not recommended for new designs. Device is in production to support existing customers, but TI does not recommend using this part in a new design.

**PREVIEW:** Device has been announced but is not in production. Samples may or may not be available.

**OBSOLETE:** TI has discontinued the production of the device.

(2) Eco Plan - The planned eco-friendly classification: Pb-Free (RoHS), Pb-Free (RoHS Exempt), or Green (RoHS & no Sb/Br) - please check <http://www.ti.com/productcontent> for the latest availability information and additional product content details.

**TBD:** The Pb-Free/Green conversion plan has not been defined.

**Pb-Free (RoHS):** TI's terms "Lead-Free" or "Pb-Free" mean semiconductor products that are compatible with the current RoHS requirements for all 6 substances, including the requirement that lead not exceed 0.1% by weight in homogeneous materials. Where designed to be soldered at high temperatures, TI Pb-Free products are suitable for use in specified lead-free processes.

**Pb-Free (RoHS Exempt):** This component has a RoHS exemption for either 1) lead-based flip-chip solder bumps used between the die and package, or 2) lead-based die adhesive used between the die and leadframe. The component is otherwise considered Pb-Free (RoHS compatible) as defined above.

**Green (RoHS & no Sb/Br):** TI defines "Green" to mean Pb-Free (RoHS compatible), and free of Bromine (Br) and Antimony (Sb) based flame retardants (Br or Sb do not exceed 0.1% by weight in homogeneous material)

(3) MSL, Peak Temp. - The Moisture Sensitivity Level rating according to the JEDEC industry standard classifications, and peak solder temperature.

(4) There may be additional marking, which relates to the logo, the lot trace code information, or the environmental category on the device.

(5) Multiple Device Markings will be inside parentheses. Only one Device Marking contained in parentheses and separated by a "~" will appear on a device. If a line is indented then it is a continuation of the previous line and the two combined represent the entire Device Marking for that device.

(6) Lead/Ball Finish - Orderable Devices may have multiple material finish options. Finish options are separated by a vertical ruled line. Lead/Ball Finish values may wrap to two lines if the finish value exceeds the maximum column width.

**Important Information and Disclaimer:** The information provided on this page represents TI's knowledge and belief as of the date that it is provided. TI bases its knowledge and belief on information provided by third parties, and makes no representation or warranty as to the accuracy of such information. Efforts are underway to better integrate information from third parties. TI has taken and continues to take reasonable steps to provide representative and accurate information but may not have conducted destructive testing or chemical analysis on incoming materials and chemicals. TI and TI suppliers consider certain information to be proprietary, and thus CAS numbers and other limited information may not be available for release.

In no event shall TI's liability arising out of such information exceed the total purchase price of the TI part(s) at issue in this document sold by TI to Customer on an annual basis.

## TAPE AND REEL INFORMATION



### QUADRANT ASSIGNMENTS FOR PIN 1 ORIENTATION IN TAPE



\*All dimensions are nominal

Device	Package Type	Package Drawing	Pins	SPQ	Reel Diameter (mm)	Reel Width W1 (mm)	A0 (mm)	B0 (mm)	K0 (mm)	P1 (mm)	W (mm)	Pin1 Quadrant
DAC088S085CIMTX/NOPB	TSSOP	PW	16	2500	330.0	12.4	6.95	5.6	1.6	8.0	12.0	Q1
DAC088S085CISQ/NOPB	WQFN	RGH	16	1000	178.0	12.4	4.3	4.3	1.3	8.0	12.0	Q1
DAC088S085CISQX/NOPB	WQFN	RGH	16	4500	330.0	12.4	4.3	4.3	1.3	8.0	12.0	Q1

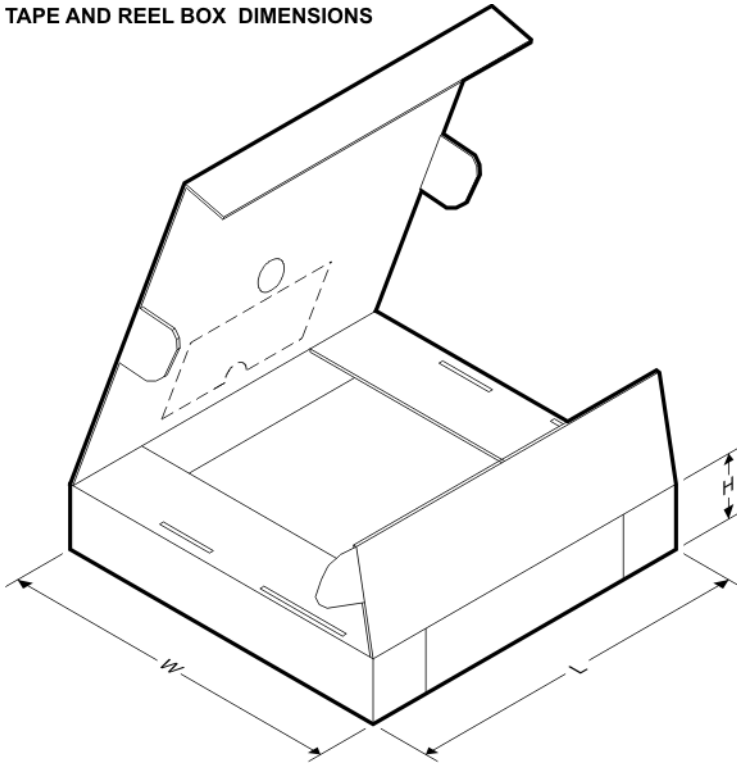
**TAPE AND REEL BOX DIMENSIONS**

\*All dimensions are nominal

Device	Package Type	Package Drawing	Pins	SPQ	Length (mm)	Width (mm)	Height (mm)
DAC088S085CIMTX/NOP B	TSSOP	PW	16	2500	367.0	367.0	35.0
DAC088S085CISQ/NOPB	WQFN	RGH	16	1000	210.0	185.0	35.0
DAC088S085CISQX/NOP B	WQFN	RGH	16	4500	367.0	367.0	35.0

# RGH0016A

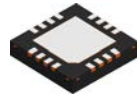

# PACKAGE OUTLINE

## WQFN - 0.8 mm max height

PLASTIC QUAD FLATPACK - NO LEAD

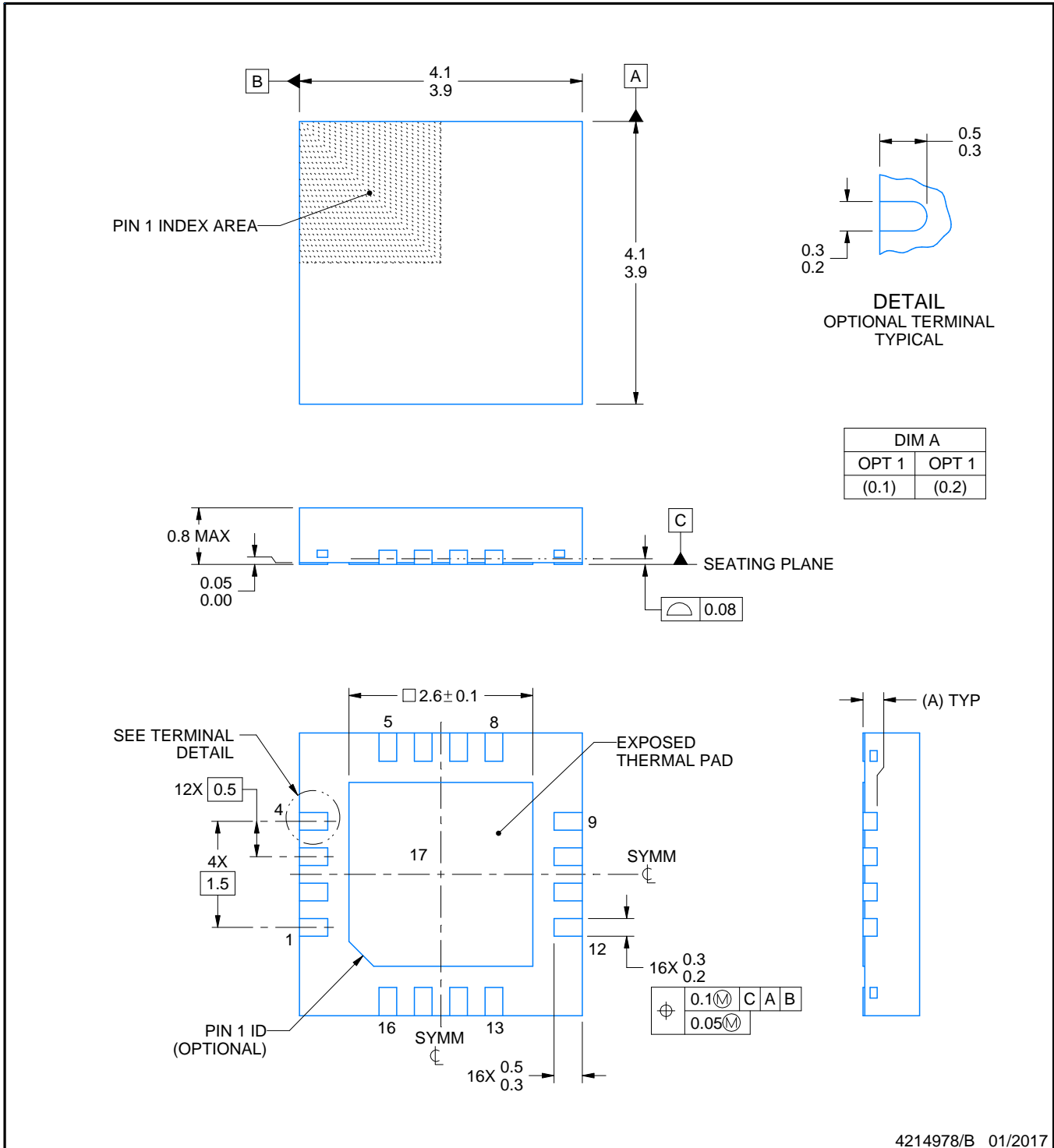

4214978/B 01/2017

**NOTES:**

1. All linear dimensions are in millimeters. Any dimensions in parenthesis are for reference only. Dimensioning and tolerancing per ASME Y14.5M.
2. This drawing is subject to change without notice.
3. The package thermal pad must be soldered to the printed circuit board for optimal thermal and mechanical performance.





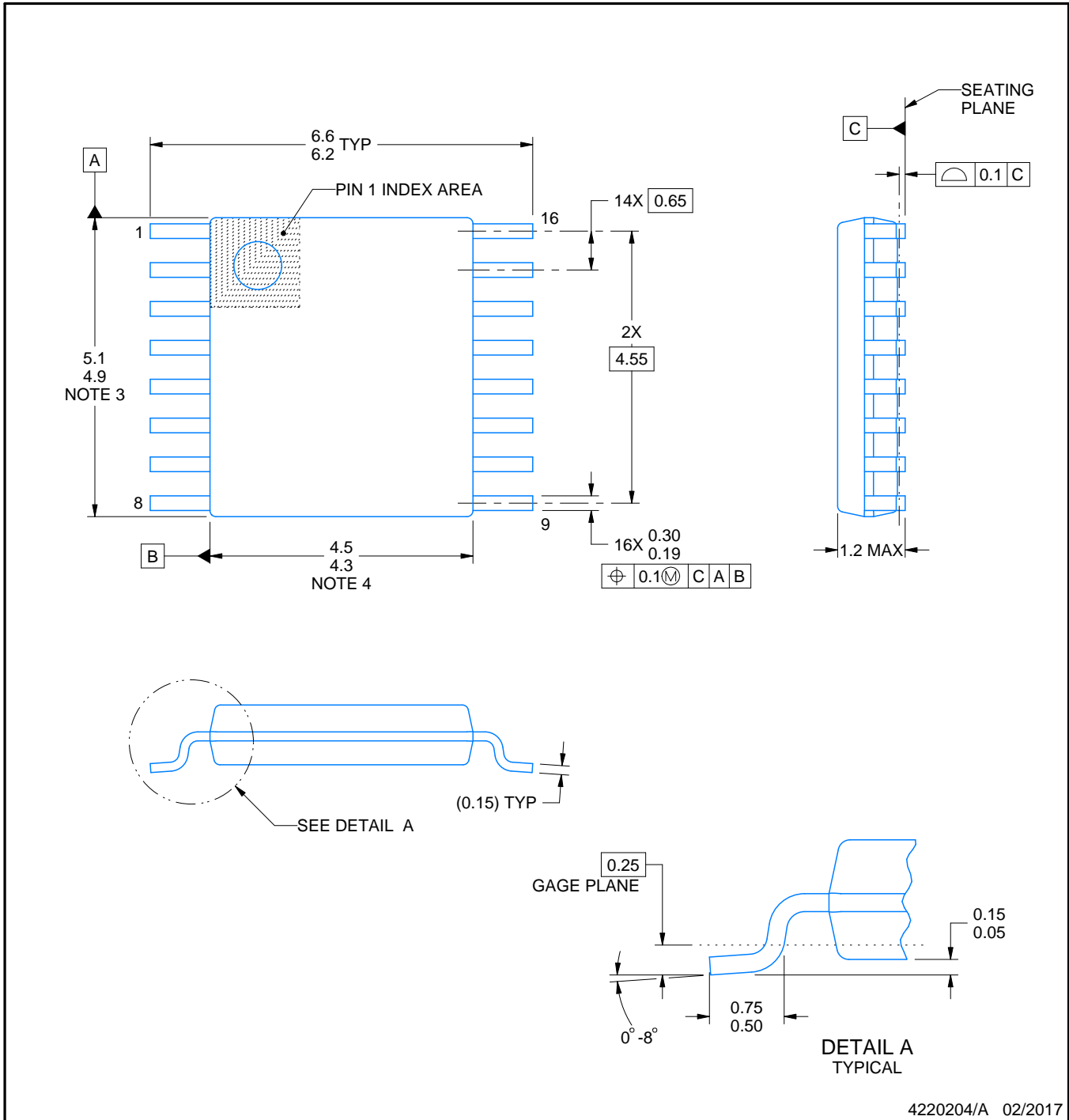
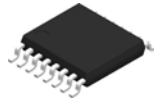

4220204/A 02/2017

NOTES:

1. All linear dimensions are in millimeters. Any dimensions in parenthesis are for reference only. Dimensioning and tolerancing per ASME Y14.5M.
2. This drawing is subject to change without notice.
3. This dimension does not include mold flash, protrusions, or gate burrs. Mold flash, protrusions, or gate burrs shall not exceed 0.15 mm per side.
4. This dimension does not include interlead flash. Interlead flash shall not exceed 0.25 mm per side.
5. Reference JEDEC registration MO-153.

# EXAMPLE BOARD LAYOUT

PW0016A

TSSOP - 1.2 mm max height

SMALL OUTLINE PACKAGE

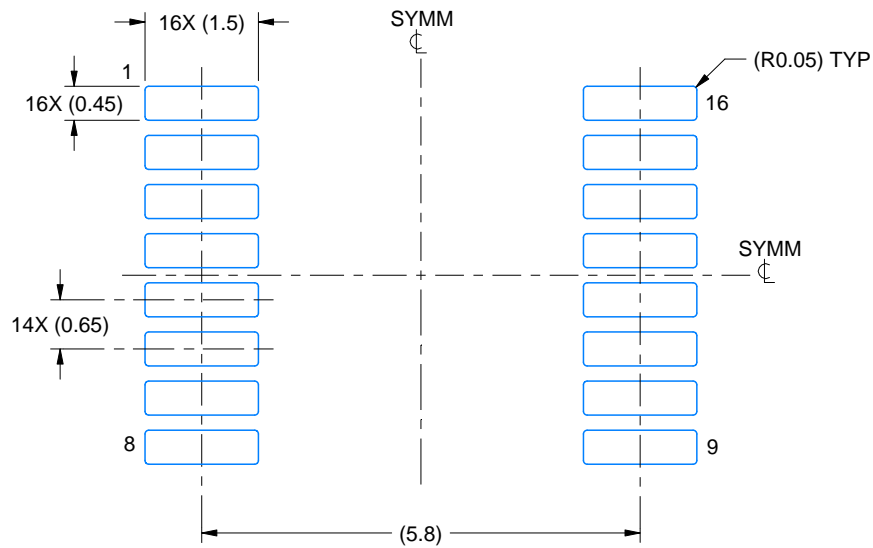

LAND PATTERN EXAMPLE  
EXPOSED METAL SHOWN  
SCALE: 10X



SOLDER MASK DETAILS

4220204/A 02/2017

NOTES: (continued)

6. Publication IPC-7351 may have alternate designs.
7. Solder mask tolerances between and around signal pads can vary based on board fabrication site.

# EXAMPLE STENCIL DESIGN

PW0016A

TSSOP - 1.2 mm max height

SMALL OUTLINE PACKAGE

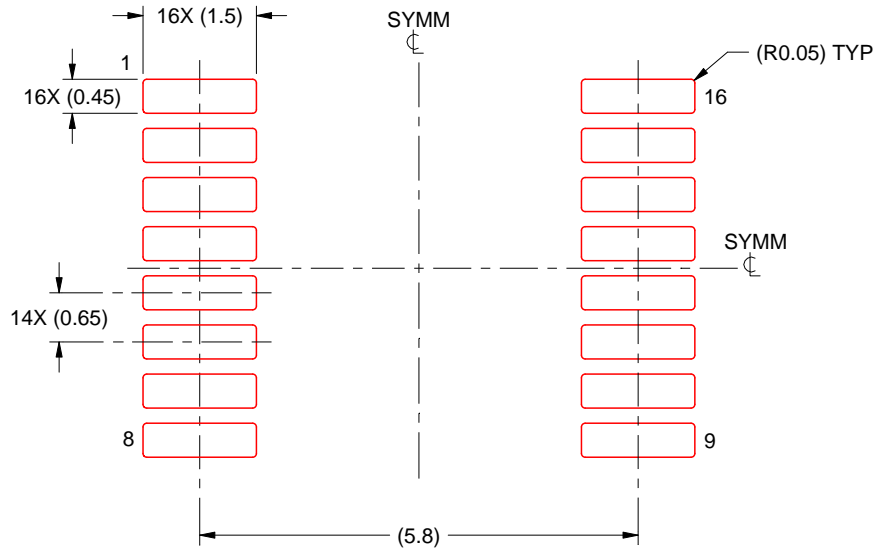

SOLDER PASTE EXAMPLE  
BASED ON 0.125 mm THICK STENCIL  
SCALE: 10X

4220204/A 02/2017

NOTES: (continued)

8. Laser cutting apertures with trapezoidal walls and rounded corners may offer better paste release. IPC-7525 may have alternate design recommendations.
9. Board assembly site may have different recommendations for stencil design.

## IMPORTANT NOTICE AND DISCLAIMER

TI PROVIDES TECHNICAL AND RELIABILITY DATA (INCLUDING DATASHEETS), DESIGN RESOURCES (INCLUDING REFERENCE DESIGNS), APPLICATION OR OTHER DESIGN ADVICE, WEB TOOLS, SAFETY INFORMATION, AND OTHER RESOURCES "AS IS" AND WITH ALL FAULTS, AND DISCLAIMS ALL WARRANTIES, EXPRESS AND IMPLIED, INCLUDING WITHOUT LIMITATION ANY IMPLIED WARRANTIES OF MERCHANTABILITY, FITNESS FOR A PARTICULAR PURPOSE OR NON-INFRINGEMENT OF THIRD PARTY INTELLECTUAL PROPERTY RIGHTS.

These resources are intended for skilled developers designing with TI products. You are solely responsible for (1) selecting the appropriate TI products for your application, (2) designing, validating and testing your application, and (3) ensuring your application meets applicable standards, and any other safety, security, or other requirements. These resources are subject to change without notice. TI grants you permission to use these resources only for development of an application that uses the TI products described in the resource. Other reproduction and display of these resources is prohibited. No license is granted to any other TI intellectual property right or to any third party intellectual property right. TI disclaims responsibility for, and you will fully indemnify TI and its representatives against, any claims, damages, costs, losses, and liabilities arising out of your use of these resources.

TI's products are provided subject to TI's Terms of Sale ([www.ti.com/legal/termsofsale.html](http://www.ti.com/legal/termsofsale.html)) or other applicable terms available either on [ti.com](http://ti.com) or provided in conjunction with such TI products. TI's provision of these resources does not expand or otherwise alter TI's applicable warranties or warranty disclaimers for TI products.

Mailing Address: Texas Instruments, Post Office Box 655303, Dallas, Texas 75265  
Copyright © 2018, Texas Instruments Incorporated

## Looking for pricing, stock, or lifecycle information?

Click below to explore more details on WIN SOURCE:

- ⊖ [View DAC088S085CISQ/NOPB on WIN SOURCE](#)
- ⊖ [Texas Instruments Information](#)

## Optimize Your Supply Chain with WIN SOURCE Solutions

- ✓ Global Sourcing Solution
- ✓ Obsolete Management
- ✓ Cost Control Management
- ✓ Shortage Management
- ✓ Alternative Solution
- ✓ Excess Inventory Management