



**THE DATASHEET OF
DCV010505P-U/700**



DCV01 Series 1-W, 1500-Vrms Isolated, Unregulated DC/DC Converter Modules

1 Features

- 1.5-kVrms Isolation (Operational)
- UL1950 Recognized Component
- EN55022 Class B EMC Performance
- 7-Pin PDIP and 7-Pin SOP Packages
- Device-to-Device Synchronization
- Thermal Protection
- Short-Circuit Protected
- 5-V, 15-V, and 24-V Inputs
- ± 5 -V, ± 12 -V, and ± 15 -V Outputs
- High Efficiency

2 Applications

- Signal Path Isolation
- Ground Loop Elimination
- Data Acquisition
- Industrial Control and Instrumentation
- Test Equipment

3 Description

The DCV01 series is a family of 1-W, 1500-Vrms isolated, unregulated DC/DC converter modules. Requiring a minimum of external components and including on-chip device protection, the DCV01 series of devices provide extra features such as output disable and synchronization of switching frequencies.

This combination of features and small size makes the DCV01 series of devices suitable for a wide range of applications, and is an easy-to-use solution in applications requiring signal path isolation.

CAUTION

This product has operational isolation and is intended for signal isolation only. It must not be used as a part of a safety isolation circuit requiring reinforced isolation. See definitions in [Feature Description](#).

Device Information⁽¹⁾

PART NUMBER	PACKAGE	BODY SIZE (NOM)
DCV01xxxx	PDIP (7)	19.18 mm x 10.60 mm
	SOP (7)	19.18 mm x 10.60 mm

(1) For all available packages, see the orderable addendum at the end of the data sheet.

Single Output Block Diagram

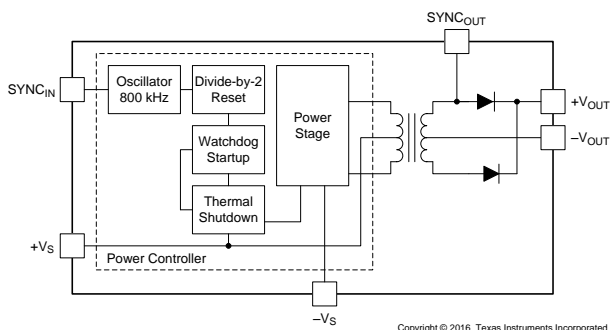

Dual Output Block Diagram

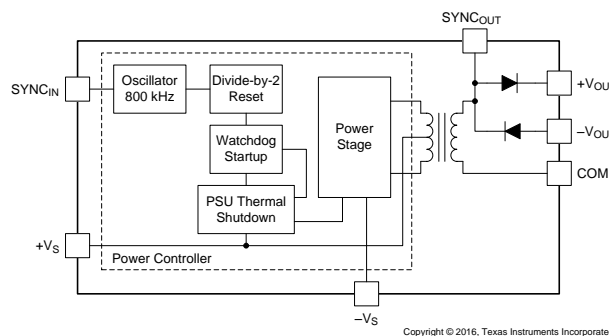

Table of Contents

1 Features	1	8.4 Device Functional Modes.....	14
2 Applications	1	9 Application and Implementation	16
3 Description	1	9.1 Application Information.....	16
4 Revision History	2	9.2 Typical Application	16
5 Device Comparison Table	3	10 Power Supply Recommendations	19
6 Pin Configuration and Functions	4	11 Layout	20
7 Specifications	5	11.1 Layout Guidelines	20
7.1 Absolute Maximum Ratings	5	11.2 Layout Example	20
7.2 ESD Ratings	5	12 Device and Documentation Support	22
7.3 Recommended Operating Conditions.....	5	12.1 Device Support	22
7.4 Thermal Information	5	12.2 Documentation Support	22
7.5 Electrical Characteristics.....	6	12.3 Related Links	22
7.6 Switching Characteristics	6	12.4 Receiving Notification of Documentation Updates	22
7.7 Typical Characteristics	7	12.5 Community Resources.....	23
8 Detailed Description	11	12.6 Trademarks	23
8.1 Overview	11	12.7 Electrostatic Discharge Caution.....	23
8.2 Functional Block Diagrams	11	12.8 Glossary	23
8.3 Feature Description.....	12	13 Mechanical, Packaging, and Orderable Information	23

4 Revision History

Changes from Revision A (December 2013) to Revision B	Page
• Changed <i>Features</i>	1
• Changed <i>Applications</i>	1
• Added <i>Device Information</i> table, <i>Device Comparison</i> table, <i>ESD Ratings</i> table, <i>Feature Description</i> section, <i>Device Functional Modes</i> , <i>Application and Implementation</i> section, <i>Power Supply Recommendations</i> section, <i>Layout</i> section, <i>Device and Documentation Support</i> section, and <i>Mechanical, Packaging, and Orderable Information</i> section.....	1
• Deleted <i>Electrical Characteristics Per Device</i> table	6
• Added additional graphs to <i>Typical Characteristics</i> section	7
• Added <i>Isolation</i> subsection to <i>Feature Description</i> section.....	12
• Deleted <i>DCH, DCP, DCR, and DCV Series DC-DC Converters</i> subsection	12
• Deleted <i>Continuous Voltage</i> subsection.....	12
• Deleted references to DCP, DCR, DCR, and DCH series	12
• Added typical application design to <i>Application Information</i> section.....	16

5 Device Comparison Table

 at $T_A = 25^\circ\text{C}$, $+V_S = \text{nominal}$, $C_{IN} = 2.2 \mu\text{F}$, and $C_{OUT} = 0.1 \mu\text{F}$ (unless otherwise noted)

DEVICE NUMBER	INPUT VOLTAGE V_S (V)			OUTPUT VOLTAGE V_{NOM} at V_S (TYP) (V) 75% LOAD			DEVICE OUTPUT CURRENT (mA) ⁽¹⁾	LOAD REGULATION 10% TO 100% LOAD ⁽²⁾		NO LOAD CURRENT I_Q (mA) 0% LOAD	EFFICIENCY (%) 100% LOAD	BARRIER CAPACITANCE C_{ISO} (pF) $V_{ISO} = 750 V_{rms}$
	MIN	TYP	MAX	MIN	TYP	MAX	MAX	TYP	MAX	TYP	TYP	TYP
DCV010505P DCV010505P-U	4.5	5	5.5	4.75	5	5.25	200	19	31	20	80	3.6
DCV010505DP DCV010505DP-U	4.5	5	5.5	±4.25	±5	±5.75	200 ⁽³⁾	18	32	22	81	3.8
DCV010512P DCV010512P-U	4.5	5	5.5	11.4	12	12.6	83	21	38	29	85	5.1
DCV010512DP DCV010512DP-U	4.5	5	5.5	±11.4	±12	±12.6	83 ⁽³⁾	19	37	40	82	4
DCV010515P DCV010515P-U	4.5	5	5.5	14.25	15	15.75	66	26	42	34	82	3.8
DCV010515DP DCV010515DP-U	4.5	5	5.5	±14.25	±15	±15.75	66 ⁽³⁾	19	41	42	85	4.7
DCV011512DP DCV011512DP-U	13.5	15	16.5	±11.4	±12	±12.6	83 ⁽³⁾	11	39	19	78	2.5
DCV011515DP DCV011515DP-U	13.5	15	16.5	±14.25	±15	±15.75	66 ⁽³⁾	12	39	20	80	2.5
DCV012405P DCV012405P-U	21.6	24	26.4	4.75	5	5.25	200	13	23	14	77	2.5
DCV012415DP DCV012415DP-U	21.6	24	26.4	±14.25	±15	±15.75	66 ⁽³⁾	10	35	17	76	3.8

 (1) $P_{OUT(max)} = 1 \text{ W}$

 (2) Load regulation = $(V_{OUT}$ at 10% load – V_{OUT} at 100%) / V_{OUT} at 75% load

 (3) $I_{OUT1} + I_{OUT2}$

6 Pin Configuration and Functions

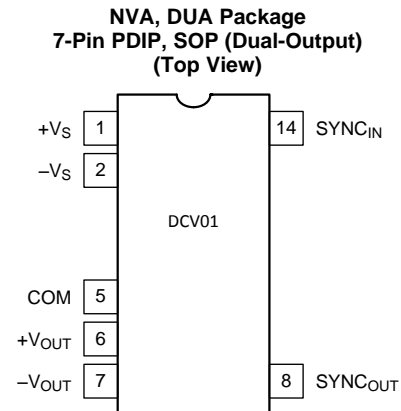
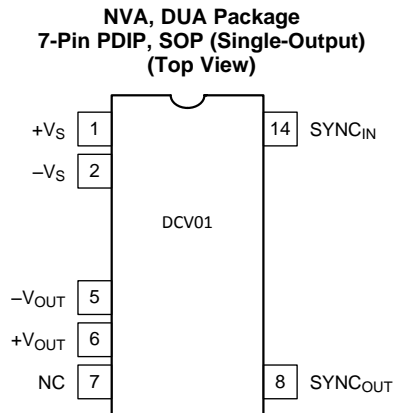

Pin Functions

NAME	PIN		I/O	DESCRIPTION
	SINGLE-OUTPUT	DUAL-OUTPUT		
COM	—	5	O	Output side common
NC	7	—	—	No connection
SYNC _{IN}	14	14	I	Synchronization. Synchronize multiple devices by connecting the SYNC pins of each. Pulling this pin low disables the internal oscillator.
SYNC _{OUT}	8	8	O	Synchronization output. Unrectified transformer output.
+V _{OUT}	6	6	O	Positive output voltage
+V _S	1	1	I	Input voltage
-V _{OUT}	5	7	O	Negative output voltage
-V _S	2	2	I	Input side common

7 Specifications

7.1 Absolute Maximum Ratings

over operating free-air temperature range (unless otherwise noted)⁽¹⁾

			MIN	MAX	UNIT
Input voltage	5-V input devices		7		V
	15-V input devices		18		
	24-V input devices		29		
Lead temperature	PDIP package	Surface temperature of device body or pins (maximum 10 s)		270	°C
Reflow solder temperature	SOP package	Surface temperature of device body or pins		260	°C
Storage temperature, T _{stg}			-60	125	°C

(1) Stresses beyond those listed under *Absolute Maximum Ratings* may cause permanent damage to the device. These are stress ratings only, which do not imply functional operation of the device at these or any other conditions beyond those indicated under *Recommended Operating Conditions*. Exposure to absolute-maximum-rated conditions for extended periods may affect device reliability.

7.2 ESD Ratings

			VALUE	UNIT
V _(ESD)	Electrostatic discharge	Human-body model (HBM), per ANSI/ESDA/JEDEC JS-001 ⁽¹⁾	±1000	V
		Charged-device model (CDM), per JEDEC specification JESD22-C101 ⁽²⁾	±250	

(1) JEDEC document JEP155 states that 500-V HBM allows safe manufacturing with a standard ESD control process.

(2) JEDEC document JEP157 states that 250-V CDM allows safe manufacturing with a standard ESD control process.

7.3 Recommended Operating Conditions

over operating free-air temperature range (unless otherwise noted)

			MIN	NOM	MAX	UNIT
Input voltage	5-V input devices		4.5	5	5.5	V
	15-V input devices		13.5	15	16.5	
	24-V input devices		21.6	24	26.4	
Operating temperature			-40		85	°C

7.4 Thermal Information

THERMAL METRIC ⁽¹⁾		DCV01	DCV01	UNIT
		NVA (PDIP)	DVB (SOP)	
		7 PINS	12 PINS	
R _{θJA}	Junction-to-ambient thermal resistance	61	61	°C/W
R _{θJC(top)}	Junction-to-case (top) thermal resistance	26	26	°C/W
R _{θJB}	Junction-to-board thermal resistance	24	24	°C/W
ψ _{JT}	Junction-to-top characterization parameter	7	7	°C/W
ψ _{JB}	Junction-to-board characterization parameter	24	24	°C/W
R _{θJC(bot)}	Junction-to-case (bottom) thermal resistance	—	—	°C/W

(1) For more information about traditional and new thermal metrics, see the [Semiconductor and IC Package Thermal Metrics](#) application report.

7.5 Electrical Characteristics

at $T_A = 25^\circ\text{C}$, $+V_S = \text{nominal}$, $C_{IN} = 2.2 \mu\text{F}$, $C_{OUT} = 1 \mu\text{F}$ (unless otherwise noted)

PARAMETER		TEST CONDITIONS	MIN	TYP	MAX	UNIT
OUTPUT						
P_{OUT}	Output power	$I_{LOAD} = 100\%$ (full load)		0.97		W
V_{RIPPLE}	Output voltage ripple	$C_{OUT} = 1 \mu\text{F}$, $I_{LOAD} = 50\%$		20		mV _{PP}
	Voltage vs temperature	$-40^\circ\text{C} \leq T_A \leq 25^\circ\text{C}$		0.046%		$^\circ\text{C}$
		$25^\circ\text{C} \leq T_A \leq 85^\circ\text{C}$		0.016%		$^\circ\text{C}$
INPUT						
V_S	Input voltage		-10%		10%	
ISOLATION						
V_{ISO}	Isolation	1-second flash test	Voltage	1.5		kVrms
			dV/dt		500	V/s
			Leakage current		30	nA
		Continuous working voltage across isolation barrier	DC		60	VDC
			AC		42.5	VAC
LINE REGULATION						
	Output voltage	$I_{OUT} \geq 10\%$ load current and constant, V_S (min) to V_S (typ)		1%	15%	
		$I_{OUT} \geq 10\%$ load current and constant, V_S (typ) to V_S (max)		1%	15%	
RELIABILITY						
	Demonstrated	$T_A = 55^\circ\text{C}$			75	FITS
THERMAL SHUTDOWN						
T_{SD}	Die temperature at shutdown			150		$^\circ\text{C}$
I_{SD}	Shutdown current			3		mA

7.6 Switching Characteristics

at $T_A = 25^\circ\text{C}$, $+V_S = \text{nominal}$, $C_{IN} = 2.2 \mu\text{F}$, $C_{OUT} = 1 \mu\text{F}$ (unless otherwise noted)

PARAMETER		TEST CONDITIONS	MIN	TYP	MAX	UNIT
f_{OSC}	Oscillator frequency	$f_{SW} = f_{OSC}/2$		800		kHz
V_{IL}	Low-level input voltage, SYNC		0		0.4	V
I_{SYNC}	Input current, SYNC	$V_{SYNC} = 2 \text{ V}$		75		μA
$t_{DISABLE}$	Disable time			2		μs
C_{SYNC}	Capacitance loading on SYNC pin ⁽¹⁾	External			3	pF

(1) [External Synchronization of the DCP01/02 Series of DC/DC Converters](#) describes this configuration.

7.7 Typical Characteristics

at $T_A = 25^\circ\text{C}$ (unless otherwise noted)

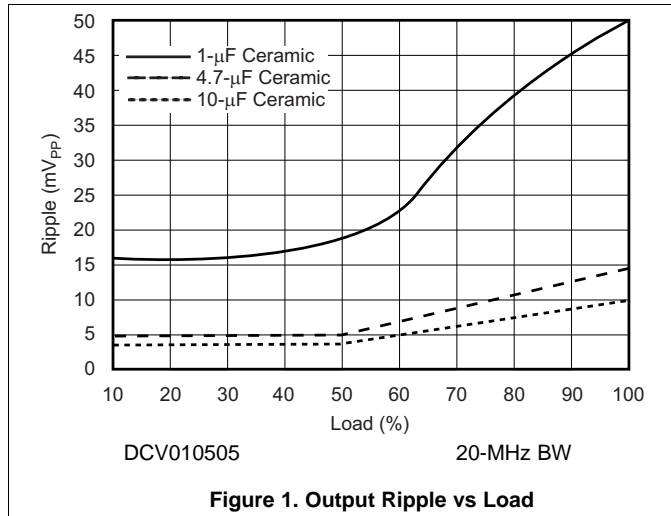

Figure 1. Output Ripple vs Load

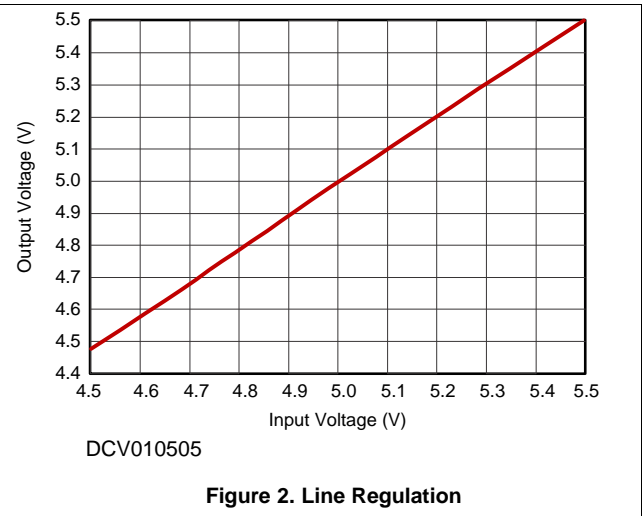

Figure 2. Line Regulation

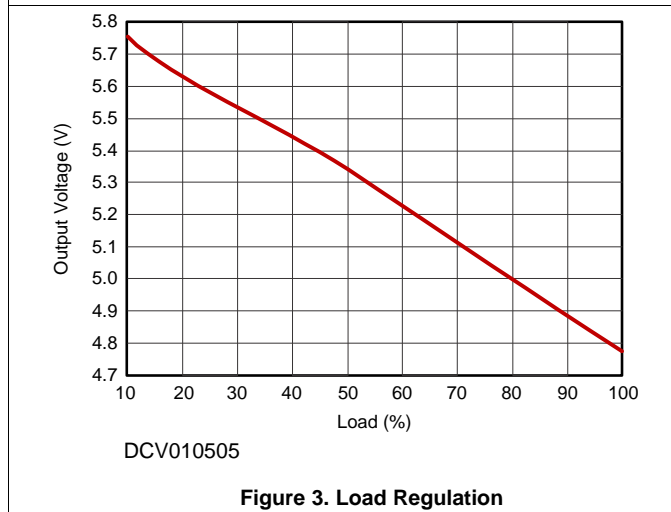

Figure 3. Load Regulation

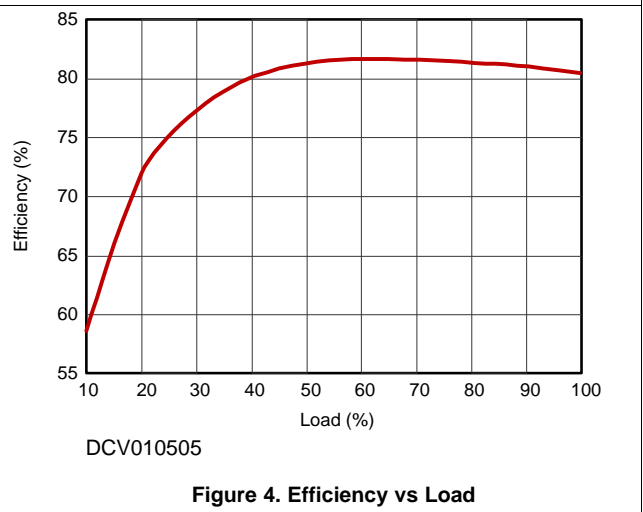

Figure 4. Efficiency vs Load

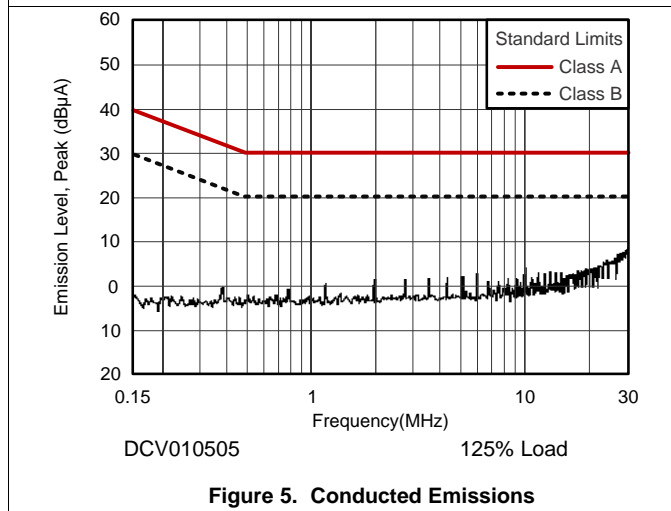

Figure 5. Conducted Emissions

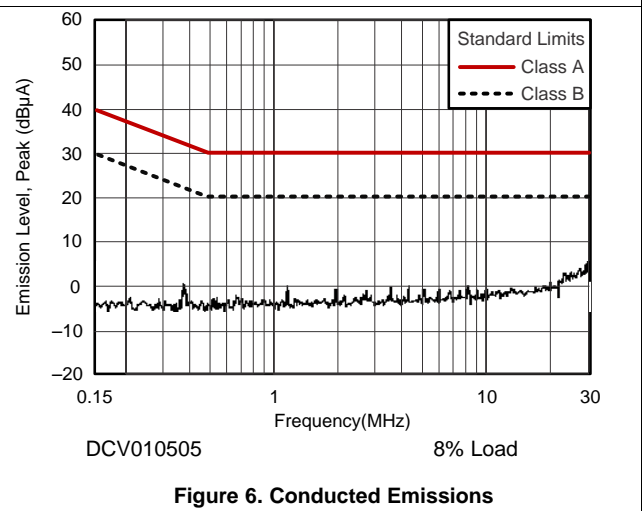
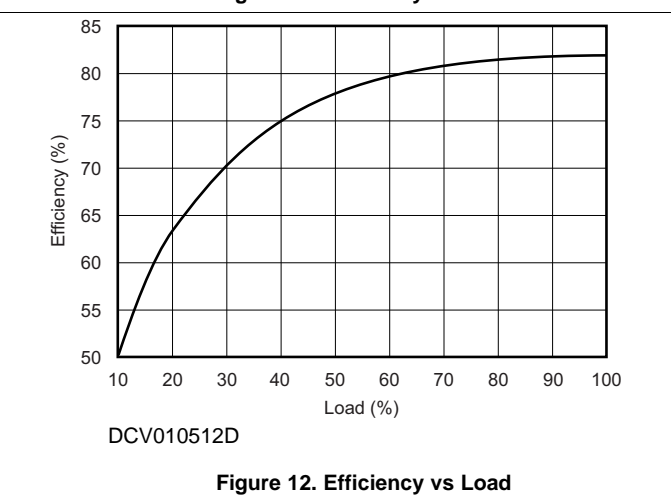
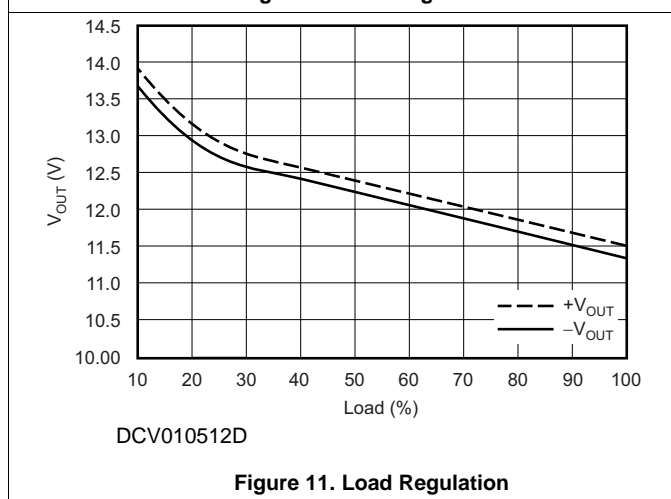
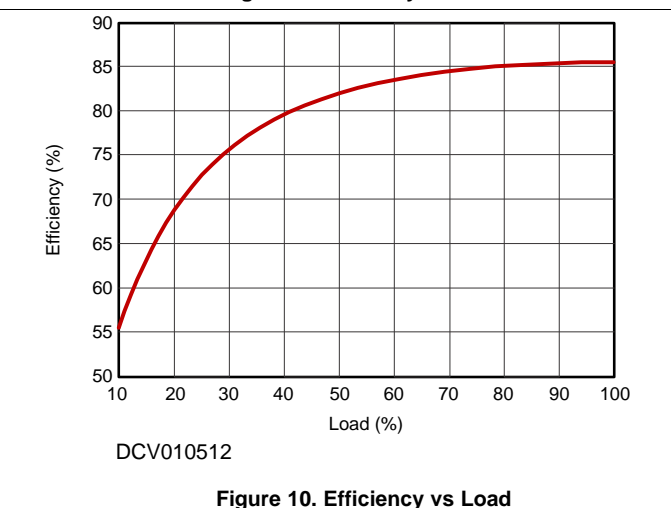
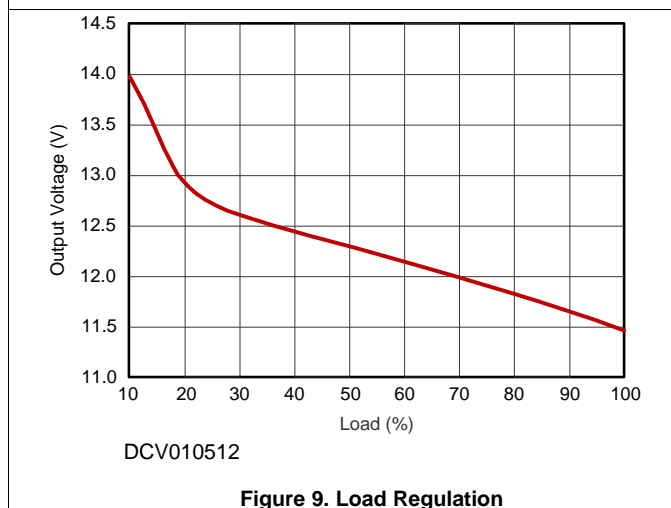
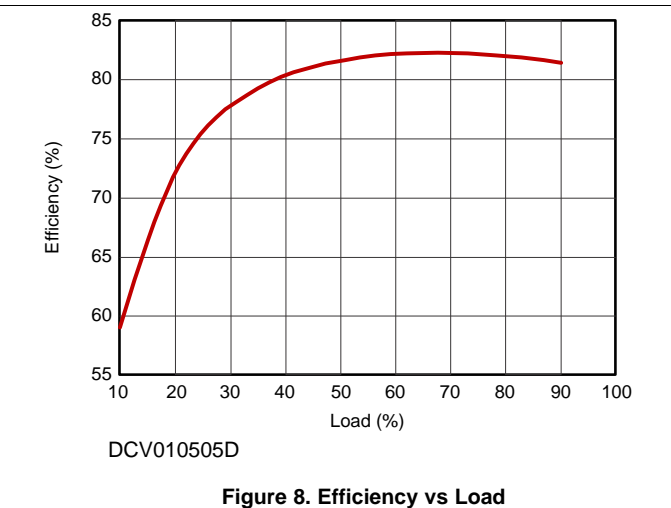
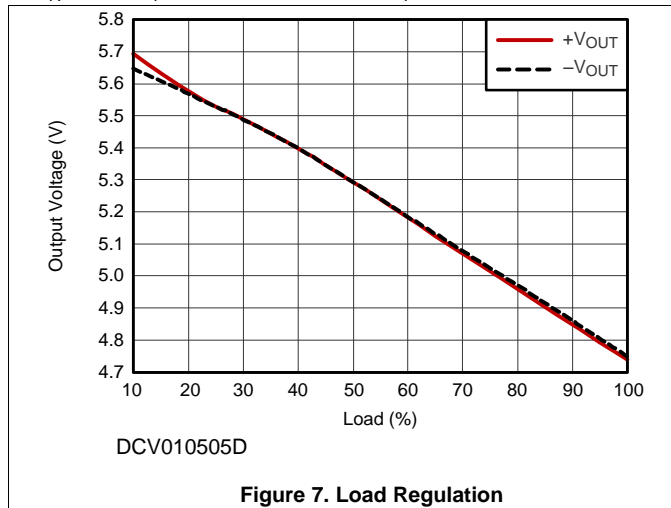

Figure 6. Conducted Emissions

Typical Characteristics (continued)

at $T_A = 25^\circ\text{C}$ (unless otherwise noted)



Typical Characteristics (continued)

at $T_A = 25^\circ\text{C}$ (unless otherwise noted)

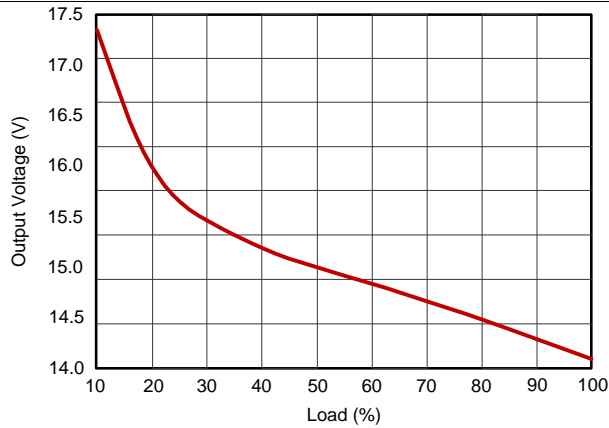

DCV010515

Figure 13. Load Regulation

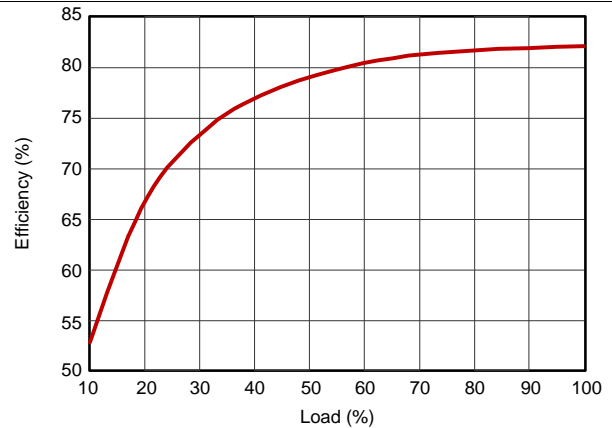

DCV010515

Figure 14. Load Regulation

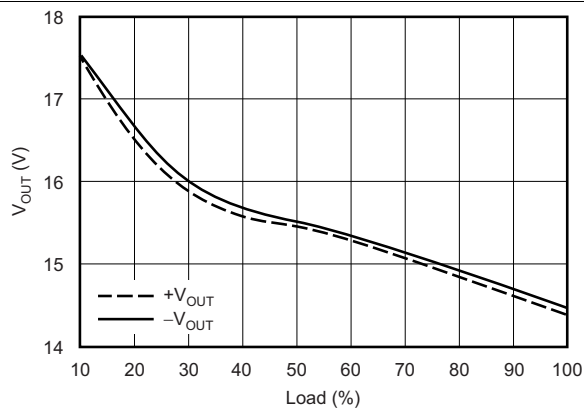

DCV010515D

Figure 15. Load Regulation

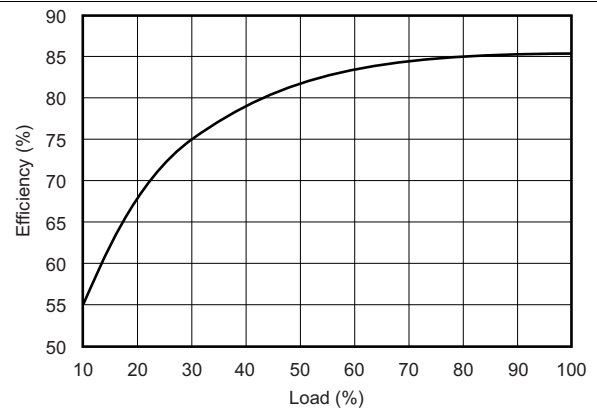

DCV010515D

Figure 16. Efficiency vs Load

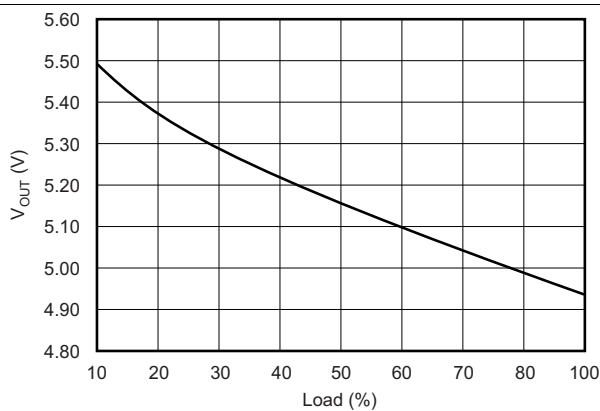

DCV012405

Figure 17. Load Regulation

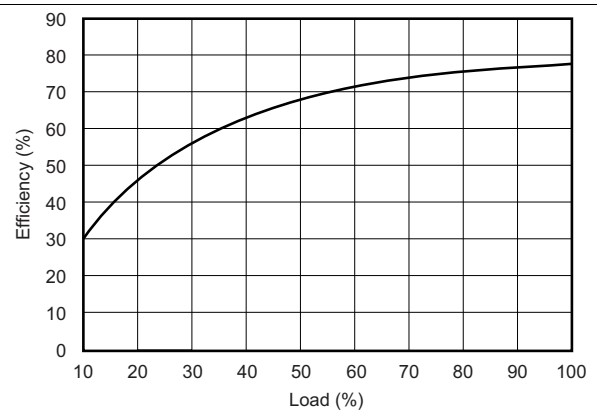

DCV012405

Figure 18. Efficiency vs Load

Typical Characteristics (continued)

at $T_A = 25^\circ\text{C}$ (unless otherwise noted)

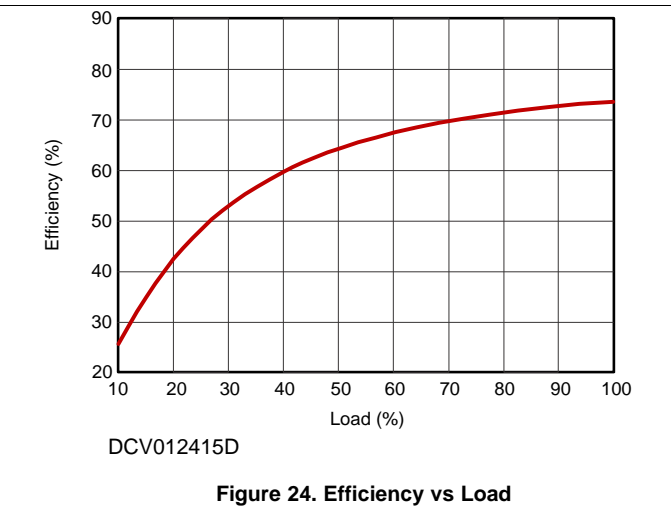
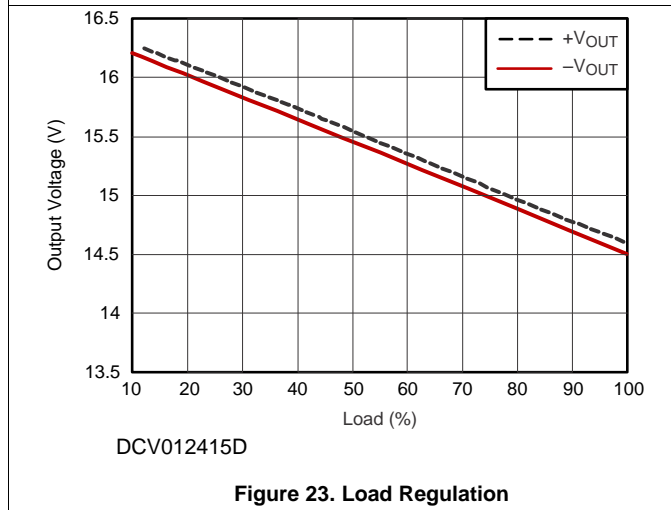
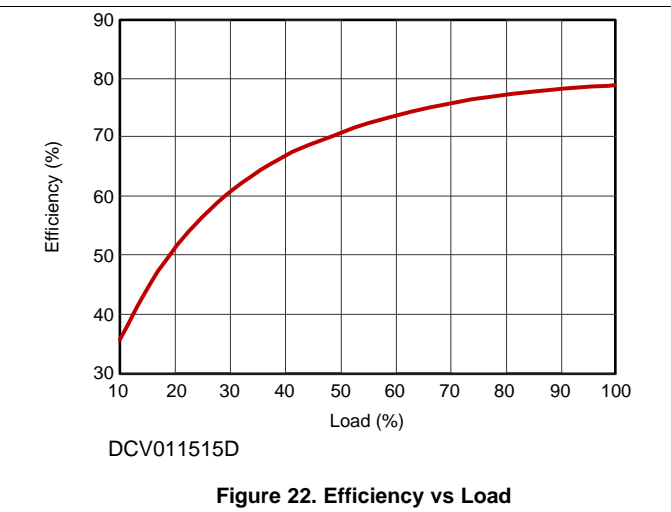
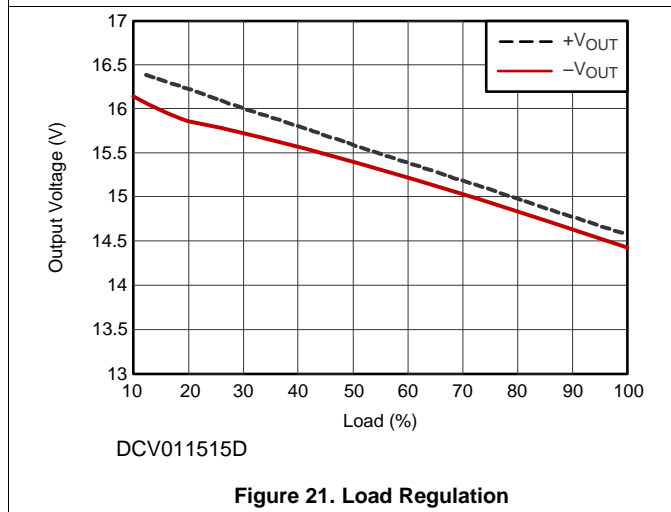
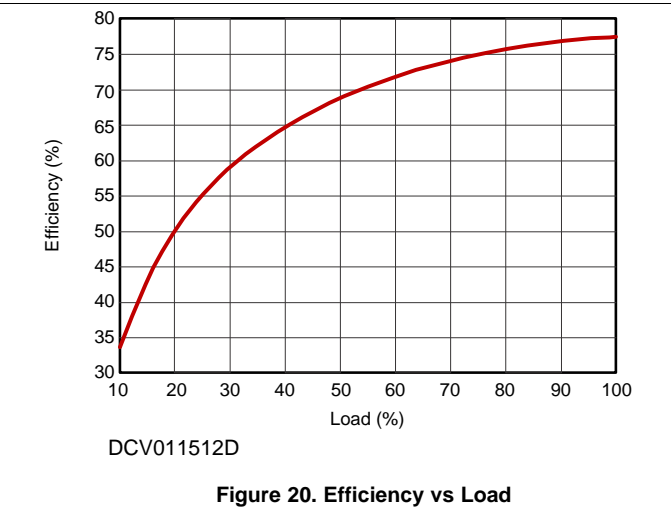
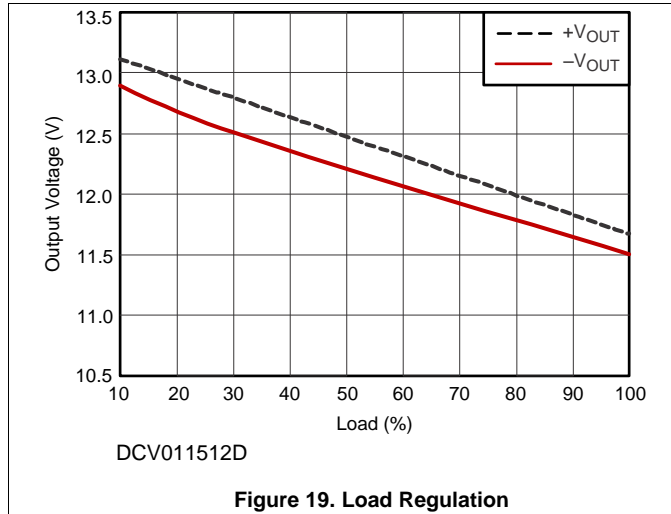

8 Detailed Description

8.1 Overview

The DCV01 offers up to 1 W of isolated, unregulated output power from a 5-V, 15-V, or 24-V input source with a typical efficiency of up to 86%. This efficiency is achieved through highly integrated packaging technology and the implementation of a custom power stage and control device. The DCV01 devices are specified for operational isolation only. The circuit design uses an advanced BiCMOS and DMOS process.

8.2 Functional Block Diagrams

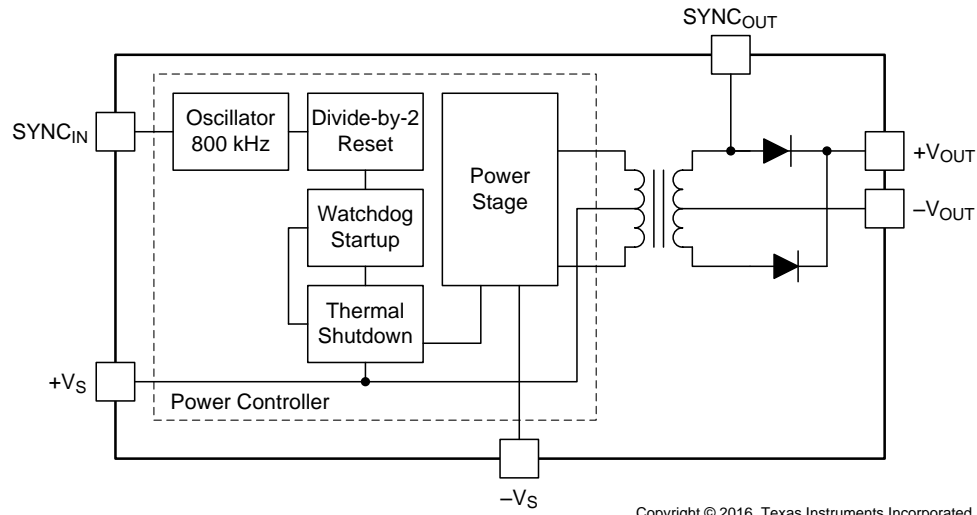

Figure 25. Single Output Device

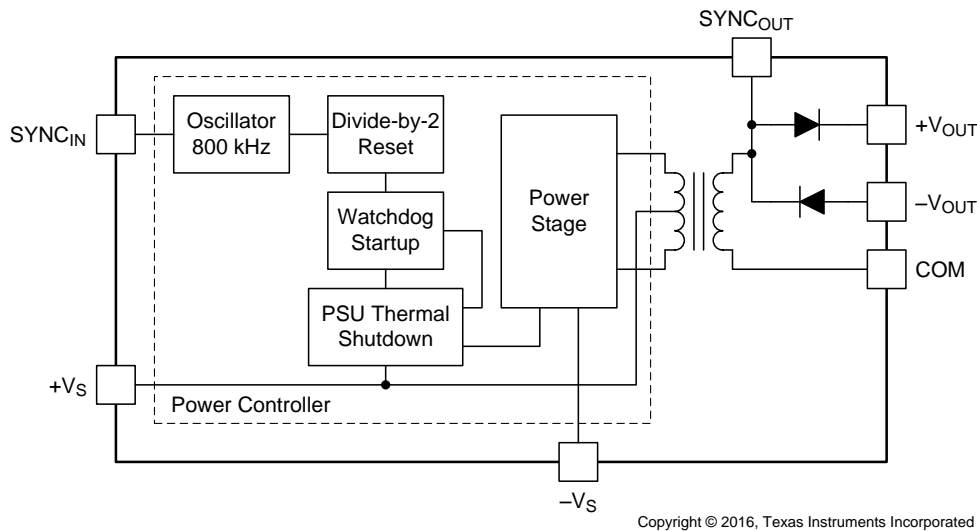

Figure 26. Dual Output Device

8.3 Feature Description

8.3.1 Isolation

Underwriters Laboratories, UL™ defines several classes of isolation that are used in modern power supplies.

Safety extra low voltage (SELV) is defined by UL (UL1950 E199929) as a secondary circuit which is so designated and protected that under normal and single fault conditions the voltage between any two accessible parts, or between an accessible part and the equipment earthing terminal for operational isolation does not exceed steady state $42.4 V_{RMS}$ or $60 V_{DC}$ peak.

8.3.1.1 Operation or Functional Isolation

The type of isolation used in the DCV01 products is referred to as operational or functional isolation. Insulated wire used in the construction of the transformer acts as the primary isolation barrier. A high-potential (hipot), one-second duration test (dielectric voltage, withstand test) is a production test used to verify that the isolation barrier is functioning. Products with operational isolation must never be used as an element in a safety-isolation system.

8.3.1.2 Basic or Enhanced Isolation

Basic or enhanced isolation is defined by specified creepage and clearance limits between the primary and secondary circuits of the power supply. Basic isolation is the use of an isolation barrier in addition to the insulated wire in the construction of the transformer. Input and output circuits must also be physically separated by specified distances.

NOTE

The DCV01 products do not provide basic or enhanced isolation.

8.3.1.3 Working Voltage

For a device with operational isolation, the continuous working voltage that can be applied across the device in normal operation must be less than $42.4 V_{RMS}$ or $60 V_{DC}$ (SELV limits).

WARNING

Do not use the device as an element of a safety isolation system if SELV is exceeded.

If the device is expected to function correctly with more than $42.4 V_{RMS}$ or $60 V_{DC}$ applied continuously across the isolation barrier, then the circuitry on both sides of the barrier must be regarded as operating at an unsafe voltage, and further isolation or insulation systems must form a barrier between these circuits and any user-accessible circuitry according to safety standard requirements.

8.3.1.4 Isolation Voltage Rating

The terms *Hipot test*, *flash-tested*, *withstand voltage*, *proof voltage*, *dielectric withstand voltage*, and *isolation test voltage* all relate to the same thing. These terms describe a test voltage that is applied across a component for a specified time, to verify the integrity of the isolation barrier of the component. TI's DCV01 series of dc-dc converters are all 100% production tested at $1.5 kV_{rms}$ for one second.

8.3.1.5 Repeated High-Voltage Isolation Testing

Repeated high-voltage isolation testing of a barrier component can degrade the isolation capability, depending on materials, construction, and environment. The DCV01 series of dc-dc converters have toroidal, enameled, wire isolation transformers with no additional insulation between the primary and secondary windings. While a device can be expected to withstand several times the stated test voltage, the isolation capability depends on the wire insulation. Any material, including this enamel (typically polyurethane), is susceptible to eventual chemical degradation when subject to very-high applied voltages. Therefore, strictly limit the number of high-voltage tests and repeated high-voltage isolation testing. However, if it is absolutely required, reduce the voltage by 20% from specified test voltage with a duration limit of one second per test.

Feature Description (continued)

8.3.2 Power Stage

The DCV01 series of devices use a push-pull, center-tapped topology. The DCV01 devices switch at 400 kHz (divide-by-2 from an 800-kHz oscillator).

8.3.3 Oscillator and Watchdog Circuit

The onboard, 800-kHz oscillator generates the switching frequency via a divide-by-2 circuit. The oscillator can be synchronized to other DCV01 device circuits or an external source, and is used to minimize system noise.

A watchdog circuit monitors the operation of the oscillator circuit. The oscillator can be disabled by pulling the SYNC pin low. When the SYNC pin goes low, the output pins transition into tri-state mode, which occurs within 2 μ s.

8.3.4 Thermal Shutdown

The DCV01 series of devices are protected by a thermal-shutdown circuit.

If the on-chip temperature rises above 150°C, the device shuts down. Normal operation resumes as soon as the temperature falls below 150°C. While the over-temperature condition continues, operation randomly cycles on and off. This cycling continues until the temperature is reduced.

8.3.5 Synchronization

When more than one DC/DC converter is needed onboard, beat frequencies and other electrical interference can be generated. This interference occurs because of the small variations in switching frequencies between the DC/DC converters.

The DCV01 series of devices overcome this interference by allowing devices to be synchronized to one another. Synchronize up to eight devices by connecting the SYNC pins of each device, taking care to minimize the capacitance of tracking. Stray capacitance (greater than 3 pF) reduces the switching frequency, or can sometimes stop the oscillator circuit. The maximum recommended voltage applied to the SYNC pin is 3 V.

For an application that uses more than eight synchronized devices use an external device to drive the SYNC pins. [External Synchronization of the DCP01/02 Series of DC/DC Converters](#) (SBAA035) describes this configuration.

NOTE

During the start-up period, all synchronized devices draw maximum current from the input simultaneously. If the input voltage falls below approximately 4 V, the devices may not start up. A ceramic capacitor must be connected close to the input pin of each device. Use a 2.2- μ F capacitor for 5-V and 15-V input devices, and a 0.47- μ F capacitor for the 24-V devices.

8.3.6 Construction

The basic construction of the DCV01 series of devices is the same as standard integrated circuits. The molded package contains no substrate. The DCV01 series of devices are constructed using an IC, rectifier diodes, and a wound magnetic toroid on a leadframe. Because the package contains no solder, the devices do not require any special printed circuit board (PCB) assembly processing. This architecture results in an isolated DC/DC converter with inherently high reliability.

8.3.7 Thermal Management

Due to the high power density of this device, it is advisable to provide ground planes on the input and output rails.

8.4 Device Functional Modes

8.4.1 Disable and Enable (SYNC_{IN} pin)

Each of the DCV01 series devices can be disabled or enabled by driving the SYNC_{IN} pin using an open-drain CMOS gate. If the SYNC_{IN} pin is pulled low, the DCV01 becomes disabled. The disable time depends upon the external loading. The internal disable function is implemented in 2 μs. Removal of the pulldown causes the DCV01 to be enabled.

Capacitive loading on the SYNC_{IN} pin must be minimized (≤ 3 pF) in order to prevent a reduction in the oscillator frequency. [External Synchronization of the DCP01/02 Series of DC/DC Converters](#) (SBAA035) describes disable/enable control circuitry.

8.4.2 Decoupling

8.4.2.1 Ripple Reduction

The high switching frequency of 400 kHz allows simple filtering. To reduce ripple, TI recommends that a minimum of 1-μF capacitor be used on the +V_{OUT} pin. For dual output devices, decouple both of the outputs to the COM pin. The required 2.2-μF, low ESR ceramic input capacitor also helps to reduce ripple and noise, (24-V input voltage versions require only 0.47 μF of input capacitance). See [DC-to-DC Converter Noise Reduction](#) (SBVA012).

8.4.2.2 Connecting the DCV01 in Series

Multiple DCV01 devices can be connected in series to provide non-standard voltage rails. This configuration is possible by using the floating outputs provided by the galvanic isolation of the DCV01.

Connect the +V_{OUT} from one DCV01 to the -V_{OUT} of another (see [Figure 27](#)). If the SYNC_{IN} pins are tied together, the self-synchronization feature of the DCV01 prevents beat frequencies on the voltage rails. The synchronization feature of the DCV01 allows easy series connection without external filtering, thus minimizing cost.

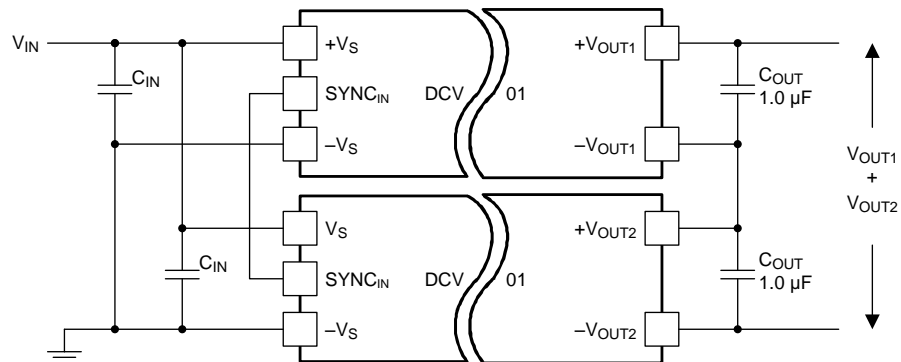

Figure 27. Multiple DCV01 Devices Connected in Series

The outputs of a dual-output DCV01 can also be connected in series to provide two times the magnitude of +V_{OUT}, as shown in [Figure 28](#). For example, connect a dual-output, 15-V, DCP012415D device to provide a 30-V rail.

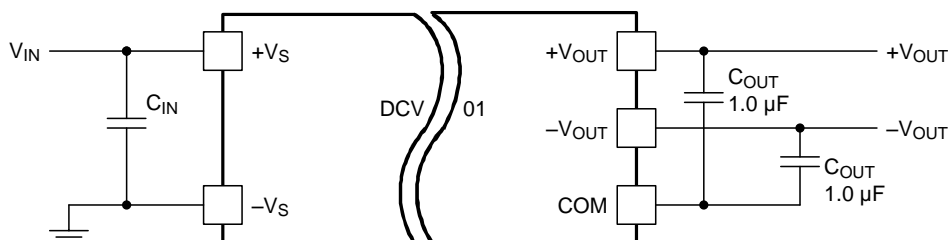

Figure 28. Dual Output Devices Connected in Series

8.4.2.3 Connecting the DCV01 in Parallel

If the output power from one DCV01 is not sufficient, it is possible to parallel the outputs of multiple DCV01s, as shown in Figure 29, (applies to single output devices only). The synchronization feature allows easy synchronization to prevent power-rail beat frequencies at no additional filtering cost.

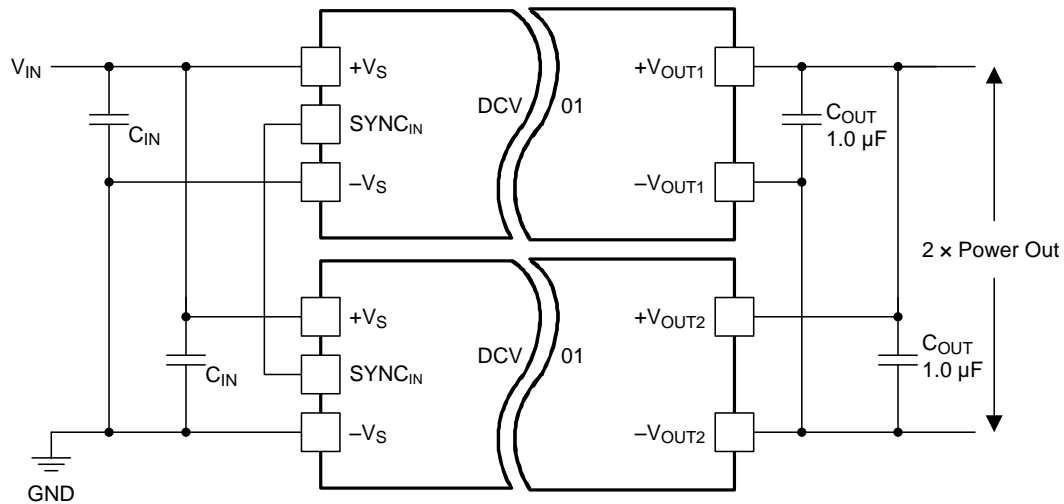

Figure 29. Multiple DCV01 Devices Connected in Parallel

9 Application and Implementation

NOTE

Information in the following applications sections is not part of the TI component specification, and TI does not warrant its accuracy or completeness. TI's customers are responsible for determining suitability of components for their purposes. Customers should validate and test their design implementation to confirm system functionality.

9.1 Application Information

The DCV01 devices offer up to 1 W of isolated, unregulated output power from a 5-V, 15-V, or 24-V input supply. Applications requiring up to 1.5-kVrms of operational isolation benefit from the small size and ease-of-use of the DCV01 family of devices.

9.2 Typical Application

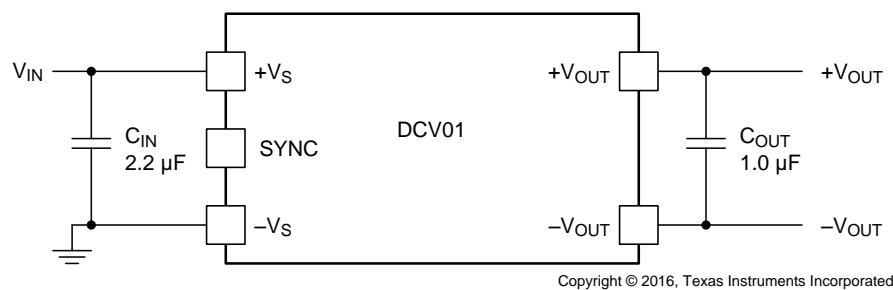

Figure 30. DCV010505 Typical Application Schematic

9.2.1 Design Requirements

For this design example, use the parameters listed in [Table 1](#) and follow the procedures in [Detailed Design Procedure](#).

Table 1. Design Example Parameters

PARAMETER	VALUE
$V_{(+VS)}$ Input voltage	5 V
$V_{(+VOUT)}$ Output voltage	5 V
I_{OUT} Output current rating	200 mA
f_{SW} Operating frequency	400 kHz

9.2.2 Detailed Design Procedure

9.2.2.1 Input Capacitor

For all 5-V and 15-V input voltage designs, select a 2.2-µF low-ESR ceramic input capacitor to ensure a good start-up performance. 24-V input applications require only 0.47-µF of input capacitance.

9.2.2.2 Output Capacitor

For any DCV01 design, select a 1-µF low-ESR ceramic output capacitor to reduce output ripple.

9.2.2.3 SYNC_{IN} Pin

In a stand-alone application, leave the SYNC_{IN} pin floating.

9.2.2.4 PCB Design

The copper losses (resistance and inductance) can be minimized by using wide ground and power traces or planes. If several devices are being powered from a common power source, a star-connected layout must be used. Device inputs must not be connected in series, as this will cascade the resistive losses. The position of the decoupling capacitors is important in order to reduce losses. Place the decoupling capacitors as close to the devices as possible. See [PCB Layout](#) for more details.

9.2.2.5 Decoupling Ceramic Capacitors

All capacitors have losses because of internal equivalent series resistance (ESR), and to a lesser degree, equivalent series inductance (ESL). Values for ESL are not always easy to obtain. However, some manufacturers provide graphs of frequency versus capacitor impedance. These graphs typically show the capacitor impedance falling as frequency is increased (as shown in [Figure 31](#)). In [Figure 31](#), X_C is the reactance due to the capacitance, X_L is the reactance due to the ESL, and f_0 is the resonant frequency. As the frequency increases, the impedance stops decreasing and begins to rise. The point of minimum impedance indicates the resonant frequency of the capacitor. This frequency is where the components of capacitance and inductance reactance are of equal magnitude. Beyond this point, the capacitor is not effective as a capacitor.

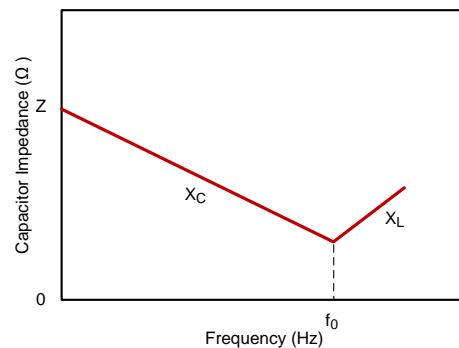

Figure 31. Capacitor Impedance vs Frequency

At f_0 , $X_C = X_L$; however, there is a 180° phase difference resulting in cancellation of the imaginary component. The resulting effect is that the impedance at the resonant point is the real part of the complex impedance; namely, the value of the ESR. The resonant frequency must be well above the 800-kHz switching frequency of the device.

The effect of the ESR is to cause a voltage drop within the capacitor. The value of this voltage drop is simply the product of the ESR and the transient load current, as shown in [Equation 1](#).

$$V_{IN} = V_{PK} - (ESR \times I_{TR})$$

where

- V_{IN} is the voltage at the device input
- V_{PK} is the maximum value of the voltage on the capacitor during charge
- I_{TR} is the transient load current

(1)

The other factor that affects the performance is the value of the capacitance. However, for the input and the full wave outputs (single-output voltage devices), ESR is the dominant factor.

9.2.2.6 Input Capacitor and the Effects of ESR

If the input decoupling capacitor is not ceramic (and has an ESR greater than 20 mΩ), then at the instant the power transistors switch on, the voltage at the input pins falls momentarily. If the voltage falls below approximately 4 V, the DCV01 detects an undervoltage condition and switches the DCV01 drive circuits to a momentary off state. This detection is carried out as a precaution against a genuine low input voltage condition that could slow down or even stop the internal circuits from operating correctly. A slow-down or stoppage results in the drive transistors being turned on too long, causing saturation of the transformer and destruction of the device.

Following detection of a low input voltage condition, the device switches off the internal drive circuits until the input voltage returns to a safe value, at which time the device tries to restart. If the input capacitor is still unable to maintain the input voltage, shutdown recurs. This process repeats until the input capacitor charges sufficiently to start the device correctly.

Normal start-up must occur in approximately 1 ms after power is applied to the device. If a considerably longer start-up duration time is encountered, it is likely that either (or both) the input supply or the capacitors are not performing adequately.

For 5-V to 15-V input devices, a 2.2- μ F, low-ESR ceramic capacitor ensures a good start-up performance. For 24-V input voltage devices, TI recommends 0.47- μ F ceramic capacitors. Tantalum capacitors are not recommended, because most do not have low-ESR values and will degrade performance. If tantalum capacitors must be used, designers must pay close attention to both the ESR and voltage as derated by the vendor.

NOTE

During the start-up period, these devices may draw maximum current from the input supply. If the input voltage falls below approximately 4 V, the devices may not start up. Connect a 2.2- μ F ceramic capacitor close to the input pins.

9.2.2.7 Ripple and Noise

A good quality, low-ESR ceramic capacitor placed as close as possible across the input reduces reflected ripple and ensures a smooth start-up.

A good quality, low-ESR ceramic capacitor placed as close as possible across the rectifier output terminal and output ground gives the best ripple and noise performance. See [DC-to-DC Converter Noise Reduction \(SBVA012\)](#) for more information on noise rejection.

9.2.2.7.1 Output Ripple Calculation Example

The following example shows that increasing the capacitance has a much smaller effect on the output ripple voltage than does reducing the value of the ESR for the filter capacitor.

To calculate the output ripple for a DCV010505 device:

- $V_{OUT} = 5 \text{ V}$
- $I_{OUT} = 0.2 \text{ A}$
- At full output power, the load resistor is 25 Ω
- Output capacitor of 1 μ F, ESR of 0.1 Ω
- Capacitor discharge time 1% of 800 kHz (ripple frequency)
- $t_{DIS} = 0.0125 \mu\text{s}$
- $\tau = C \times R_{LOAD}$
- $\tau = 1 \times 10^{-6} \times 25 = 25 \mu\text{s}$
- $V_{DIS} = V_O(1 - \text{EXP}(-t_{DIS}/\tau))$
- $V_{DIS} = 2.5 \text{ mV}$

By contrast, the voltage dropped because of ESR:

- $V_{ESR} = I_{LOAD} \times \text{ESR}$
- $V_{ESR} = 0.2 \times 0.1 = 20 \text{ mV}$
- Ripple voltage = 22.5 mV

9.2.2.8 Dual DCV01 Output Voltage

The voltage output for dual DCV01 devices is half-wave rectified; therefore, the discharge time is 1.25 μ s. Repeating the previous calculations using the 100% load resistance of 50 Ω (0.1 A per output), the results are:

- $\tau = 50 \mu\text{s}$
- $t_{DIS} = 1.25 \mu\text{s}$
- $V_{DIS} = 123 \text{ mV}$
- $V_{ESR} = 0.1 \times 0.1 = 10 \text{ mV}$
- Ripple Voltage = 133 mV

In this example, it is the capacitor discharging that contributes to the largest component of ripple. Changing the output filter to 10 μ F, and repeating the calculations, the result is that the ripple voltage is 22.3 mV.

This value is composed of almost equal components.

The previous calculations are offered as a guideline only. Capacitor parameters usually have large tolerances and can be susceptible to environmental conditions.

9.2.2.9 Optimizing Performance

Optimum performance can only be achieved if the device is correctly supported. The very nature of a switching converter requires power to be instantly available when it switches on. If the converter has DMOS switching transistors, the fast edges create a high current demand on the input supply. This transient load placed on the input is supplied by the external input decoupling capacitor, thus maintaining the input voltage. Therefore, the input supply does not experience this transient (this is analogous to high-speed digital circuits). The positioning of the capacitor is critical and must be placed as close as possible to the input pins and connected through a low-impedance path.

The optimum performance primarily depends on two factors:

- Connection of the input and output circuits for minimal loss.
- The ability of the decoupling capacitors to maintain the input and output voltages at a constant level.

9.2.3 Application Curves

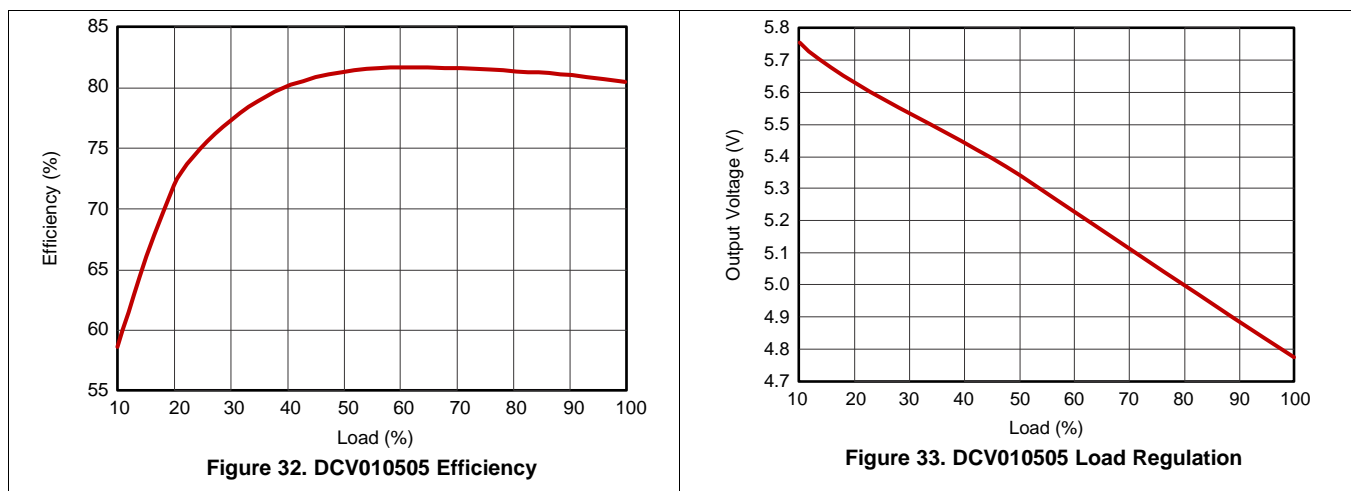

10 Power Supply Recommendations

The DCV01 is a switching power supply, and as such can place high peak current demands on the input supply. To avoid the supply falling momentarily during the fast switching pulses, ground and power planes must be used to connect the power to the input of DCV01. If this connection is not possible, then the supplies must be connected in a star formation with the traces made as wide as possible.

11 Layout

11.1 Layout Guidelines

Due to the high power density of these devices, provide ground planes on the input and output.

Figure 34 shows a schematic for two DCV01 devices. Figure 35 and Figure 36 show a typical layout for two through-hole PDIP devices.

Input power and ground planes provide a low-impedance path for the input power. For the output, the COM signal connects through a ground plane, while the connections for the positive and negative voltage outputs conduct through wide traces to minimize losses.

The output must be taken from the device using ground and power planes, thereby ensuring minimum losses.

The location of the decoupling capacitors in close proximity to their respective pins ensures low losses due to the effects of stray inductance, thus improving the ripple performance. This location is of particular importance to the input decoupling capacitor, because this capacitor supplies the transient current associated with the fast switching waveforms of the power drive circuits.

Allow the unused SYNC pin, to remain configured as a floating pad. It is advisable to place a guard ring (connected to input ground) or annulus connected around this pin to avoid any noise pickup. When connecting a SYNC pin to one or more SYNC design the linking trace to be short and narrow to avoid stray capacitance. Ensure that no other trace is in close proximity to this trace SYNC trace to decrease the stray capacitance on this pin. The stray capacitance affects the performance of the oscillator.

11.2 Layout Example

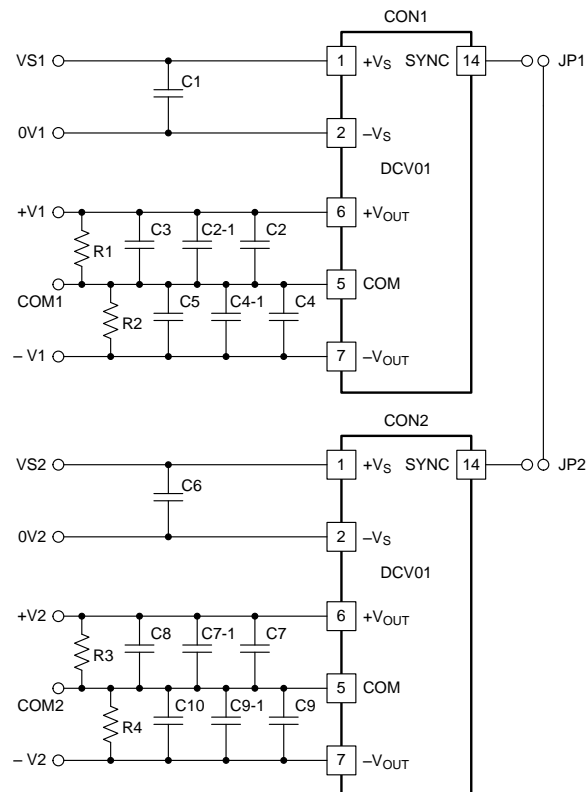

Figure 34. PCB Schematic, P and U Package

Layout Example (continued)

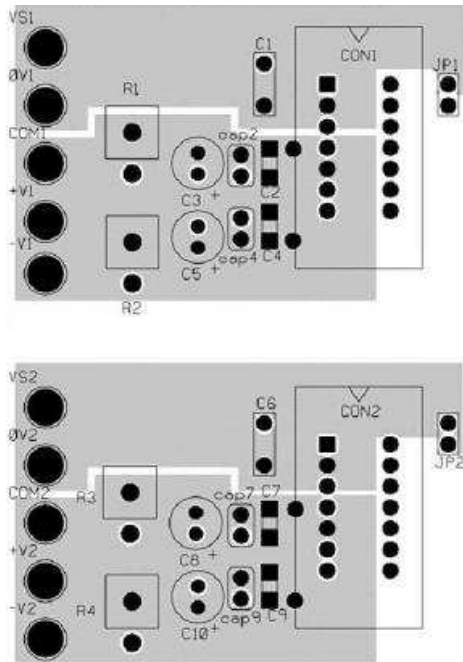

Figure 35. PCB Layout Example, Component-Side View

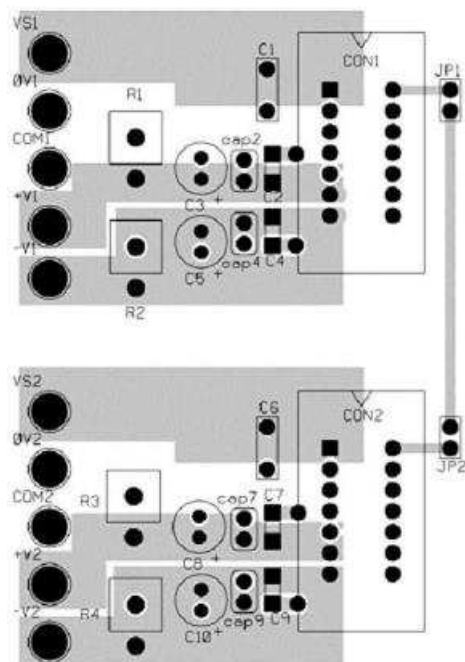

Figure 36. PCB Layout Example, Non-Component-Side View

12 Device and Documentation Support

12.1 Device Support

12.1.1 Device Nomenclature

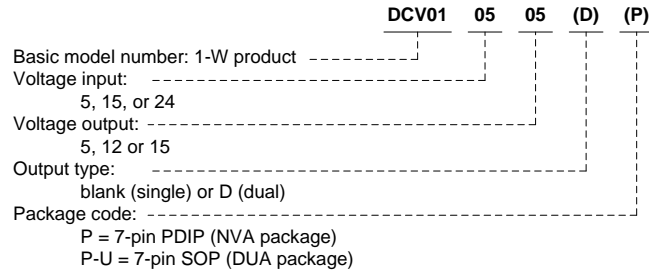

Figure 37. Supplemental Ordering Information

12.2 Documentation Support

12.2.1 Related Documentation

For related documentation see the following:

- [External Synchronization of the DCP01/02 Series of DC/DC Converters](#) (SBAA035)
- [DC-to-DC Converter Noise Reduction](#) (SBVA012)
- [Optimizing Performance of the DCP01/02 Series of DC/DC Converters](#) (SBVA013)

12.3 Related Links

The table below lists quick access links. Categories include technical documents, support and community resources, tools and software, and quick access to sample or buy.

Table 2. Related Links

PARTS	PRODUCT FOLDER	SAMPLE & BUY	TECHNICAL DOCUMENTS	TOOLS & SOFTWARE	SUPPORT & COMMUNITY
DCV010505	Click here	Click here	Click here	Click here	Click here
DCV010505D	Click here	Click here	Click here	Click here	Click here
DCV010512	Click here	Click here	Click here	Click here	Click here
DCV010512D	Click here	Click here	Click here	Click here	Click here
DCV010515	Click here	Click here	Click here	Click here	Click here
DCV010515D	Click here	Click here	Click here	Click here	Click here
DCV011512D	Click here	Click here	Click here	Click here	Click here
DCV011515D	Click here	Click here	Click here	Click here	Click here
DCV012405	Click here	Click here	Click here	Click here	Click here
DCV012415D	Click here	Click here	Click here	Click here	Click here

12.4 Receiving Notification of Documentation Updates

To receive notification of documentation updates, navigate to the device product folder on ti.com. In the upper right corner, click on *Alert me* to register and receive a weekly digest of any product information that has changed. For change details, review the revision history included in any revised document.

12.5 Community Resources

The following links connect to TI community resources. Linked contents are provided "AS IS" by the respective contributors. They do not constitute TI specifications and do not necessarily reflect TI's views; see TI's [Terms of Use](#).

TI E2E™ Online Community *TI's Engineer-to-Engineer (E2E) Community*. Created to foster collaboration among engineers. At e2e.ti.com, you can ask questions, share knowledge, explore ideas and help solve problems with fellow engineers.

Design Support *TI's Design Support* Quickly find helpful E2E forums along with design support tools and contact information for technical support.

12.6 Trademarks

E2E is a trademark of Texas Instruments.
Underwriters Laboratories, UL are trademarks of UL LLC.
All other trademarks are the property of their respective owners.

12.7 Electrostatic Discharge Caution



These devices have limited built-in ESD protection. The leads should be shorted together or the device placed in conductive foam during storage or handling to prevent electrostatic damage to the MOS gates.

12.8 Glossary

SLYZ022 — *TI Glossary*.

This glossary lists and explains terms, acronyms, and definitions.

13 Mechanical, Packaging, and Orderable Information

The following pages include mechanical, packaging, and orderable information. This information is the most current data available for the designated devices. This data is subject to change without notice and revision of this document. For browser-based versions of this data sheet, refer to the left-hand navigation.

PACKAGING INFORMATION

Orderable Device	Status (1)	Package Type	Package Drawing	Pins	Package Qty	Eco Plan (2)	Lead/Ball Finish (6)	MSL Peak Temp (3)	Op Temp (°C)	Device Marking (4/5)	Samples
DCV010505DP	ACTIVE	PDIP	NVA	7	25	Pb-Free (RoHS)	CU NIPDAU	N / A for Pkg Type	-40 to 85	DCV010505DP	Samples
DCV010505DP-U	ACTIVE	SOP	DUA	7	25	Pb-Free (RoHS)	CU NIPDAU	Level-3-260C-168 HR	-40 to 85	DCV010505DP-U	Samples
DCV010505P	ACTIVE	PDIP	NVA	7	25	Pb-Free (RoHS)	CU NIPDAU	N / A for Pkg Type	-40 to 85	DCV010505P	Samples
DCV010505P-U	ACTIVE	SOP	DUA	7	25	Pb-Free (RoHS)	CU NIPDAU	Level-3-260C-168 HR	-40 to 85	DCV010505P-U	Samples
DCV010505P-U/700	ACTIVE	SOP	DUA	7	700	Pb-Free (RoHS)	CU NIPDAU	Level-3-260C-168 HR	-40 to 85	DCV010505P-U	Samples
DCV010512DP	ACTIVE	PDIP	NVA	7	25	Pb-Free (RoHS)	CU NIPDAU	N / A for Pkg Type	-40 to 85	DCV010512DP	Samples
DCV010512DP-U	ACTIVE	SOP	DUA	7	25	Pb-Free (RoHS)	CU NIPDAU	Level-3-260C-168 HR	-40 to 85	DCV010512DP-U	Samples
DCV010512P	ACTIVE	PDIP	NVA	7	25	Pb-Free (RoHS)	CU NIPDAU	N / A for Pkg Type	-40 to 85	DCV010512P	Samples
DCV010512P-U	ACTIVE	SOP	DUA	7	25	Pb-Free (RoHS)	CU NIPDAU	Level-3-260C-168 HR	-40 to 85	DCV010512P-U	Samples
DCV010515DP	ACTIVE	PDIP	NVA	7	25	Pb-Free (RoHS)	CU NIPDAU	N / A for Pkg Type	-40 to 85	DCV010515DP	Samples
DCV010515DP-U	ACTIVE	SOP	DUA	7	25	Pb-Free (RoHS)	CU NIPDAU	Level-3-260C-168 HR	-40 to 85	DCV010515DP-U	Samples
DCV010515P	ACTIVE	PDIP	NVA	7	25	Pb-Free (RoHS)	CU NIPDAU	N / A for Pkg Type	-40 to 85	DCV010515P	Samples
DCV010515P-U	ACTIVE	SOP	DUA	7	25	Pb-Free (RoHS)	CU NIPDAU	Level-3-260C-168 HR	-40 to 85	DCV010515P-U	Samples
DCV011512DP	ACTIVE	PDIP	NVA	7	25	Pb-Free (RoHS)	CU NIPDAU	N / A for Pkg Type	-40 to 85	DCV011512DP	Samples
DCV011512DP-U	ACTIVE	SOP	DUA	7	25	Pb-Free (RoHS)	CU NIPDAU	Level-3-260C-168 HR	-40 to 85	DCV011512DP-U	Samples
DCV011515DP	ACTIVE	PDIP	NVA	7	25	Pb-Free (RoHS)	CU NIPDAU	N / A for Pkg Type	-40 to 85	DCV011515DP	Samples
DCV011515DP-U	ACTIVE	SOP	DUA	7	25	Pb-Free (RoHS)	CU NIPDAU	Level-3-260C-168 HR	-40 to 85	DCV011515DP-U	Samples

Orderable Device	Status (1)	Package Type	Package Drawing	Pins	Package Qty	Eco Plan (2)	Lead/Ball Finish (6)	MSL Peak Temp (3)	Op Temp (°C)	Device Marking (4/5)	Samples
DCV011515DP-U/700	ACTIVE	SOP	DUA	7	700	Pb-Free (RoHS)	CU NIPDAU	Level-3-260C-168 HR	-40 to 85	DCV011515DP-U	Samples
DCV012405P	ACTIVE	PDIP	NVA	7	25	Pb-Free (RoHS)	CU NIPDAU	N / A for Pkg Type	-40 to 85	DCV012405P	Samples
DCV012405P-U	ACTIVE	SOP	DUA	7	25	Pb-Free (RoHS)	CU NIPDAU	Level-3-260C-168 HR	-40 to 85	DCV012405P-U	Samples
DCV012415DP	ACTIVE	PDIP	NVA	7	25	Pb-Free (RoHS)	CU NIPDAU	N / A for Pkg Type	-40 to 85	DCV012415DP	Samples
DCV012415DP-U	ACTIVE	SOP	DUA	7	25	Pb-Free (RoHS)	CU NIPDAU	Level-3-260C-168 HR	-40 to 85	DCV012415DP-U	Samples
DCV012415DP-U/700	ACTIVE	SOP	DUA	7	700	Pb-Free (RoHS)	CU NIPDAU	Level-3-260C-168 HR	-40 to 85	DCV012415DP-U	Samples

(1) The marketing status values are defined as follows:

ACTIVE: Product device recommended for new designs.

LIFEBUY: TI has announced that the device will be discontinued, and a lifetime-buy period is in effect.

NRND: Not recommended for new designs. Device is in production to support existing customers, but TI does not recommend using this part in a new design.

PREVIEW: Device has been announced but is not in production. Samples may or may not be available.

OBSOLETE: TI has discontinued the production of the device.

(2) Eco Plan - The planned eco-friendly classification: Pb-Free (RoHS), Pb-Free (RoHS Exempt), or Green (RoHS & no Sb/Br) - please check <http://www.ti.com/productcontent> for the latest availability information and additional product content details.

TBD: The Pb-Free/Green conversion plan has not been defined.

Pb-Free (RoHS): TI's terms "Lead-Free" or "Pb-Free" mean semiconductor products that are compatible with the current RoHS requirements for all 6 substances, including the requirement that lead not exceed 0.1% by weight in homogeneous materials. Where designed to be soldered at high temperatures, TI Pb-Free products are suitable for use in specified lead-free processes.

Pb-Free (RoHS Exempt): This component has a RoHS exemption for either 1) lead-based flip-chip solder bumps used between the die and package, or 2) lead-based die adhesive used between the die and leadframe. The component is otherwise considered Pb-Free (RoHS compatible) as defined above.

Green (RoHS & no Sb/Br): TI defines "Green" to mean Pb-Free (RoHS compatible), and free of Bromine (Br) and Antimony (Sb) based flame retardants (Br or Sb do not exceed 0.1% by weight in homogeneous material)

(3) MSL, Peak Temp. - The Moisture Sensitivity Level rating according to the JEDEC industry standard classifications, and peak solder temperature.

(4) There may be additional marking, which relates to the logo, the lot trace code information, or the environmental category on the device.

(5) Multiple Device Markings will be inside parentheses. Only one Device Marking contained in parentheses and separated by a "-" will appear on a device. If a line is indented then it is a continuation of the previous line and the two combined represent the entire Device Marking for that device.

⁽⁶⁾ Lead/Ball Finish - Orderable Devices may have multiple material finish options. Finish options are separated by a vertical ruled line. Lead/Ball Finish values may wrap to two lines if the finish value exceeds the maximum column width.

Important Information and Disclaimer:The information provided on this page represents TI's knowledge and belief as of the date that it is provided. TI bases its knowledge and belief on information provided by third parties, and makes no representation or warranty as to the accuracy of such information. Efforts are underway to better integrate information from third parties. TI has taken and continues to take reasonable steps to provide representative and accurate information but may not have conducted destructive testing or chemical analysis on incoming materials and chemicals. TI and TI suppliers consider certain information to be proprietary, and thus CAS numbers and other limited information may not be available for release.

In no event shall TI's liability arising out of such information exceed the total purchase price of the TI part(s) at issue in this document sold by TI to Customer on an annual basis.

NVA (R-PDIP-T7/14)

PLASTIC DUAL-IN-LINE

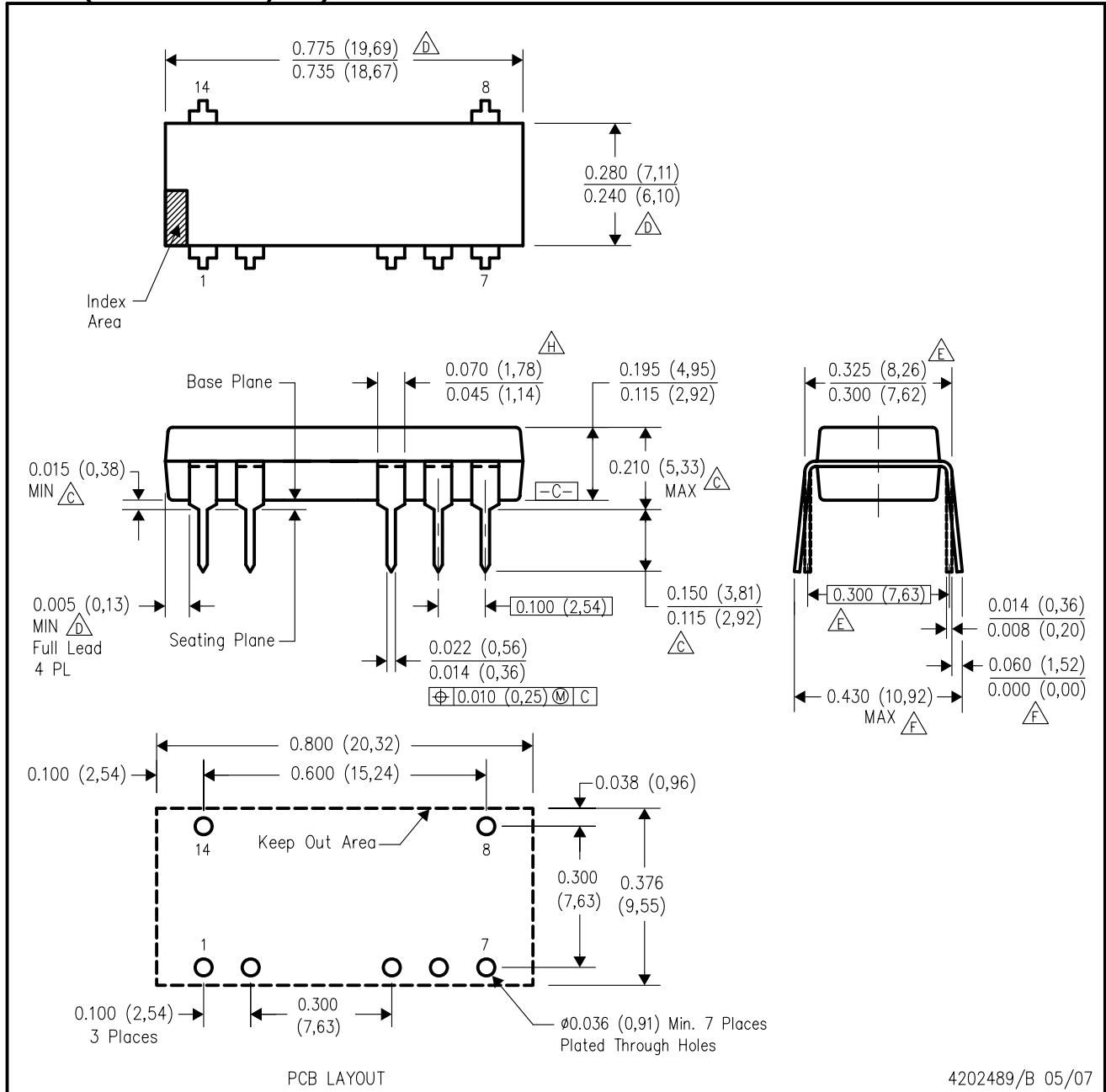

4202489/B 05/07

- NOTES:
- A. All linear dimensions are in inches (millimeters).
 - B. This drawing is subject to change without notice.
 - \triangle Dimensions are measured with the package seated in JEDEC seating plane gauge GS-3.
 - \triangle Dimensions do not include mold flash or protrusions. Mold flash or protrusions shall not exceed 0.010 (0,25).
 - \triangle Dimensions measured with the leads constrained to be perpendicular to Datum C.
 - \triangle Dimensions are measured at the lead tips with the leads unconstrained.
 - G. Pointed or rounded lead tips are preferred to ease insertion.
 - \triangle Lead shoulder maximum dimension does not include dambar protrusions. Dambar protrusions shall not exceed 0.010 (0,25).
 - I. Distance between leads including dambar protrusions to be 0.005 (0,13) minimum.
 - J. A visual index feature must be located within the cross-hatched area.
 - K. For automatic insertion, any raised irregularity on the top surface (step, mesa, etc.) shall be symmetrical about the lateral and longitudinal package centerlines.
 - L. Falls within JEDEC MS-001-AA.

DUA (R-PDSO-G7/14)

PLASTIC SMALL-OUTLINE

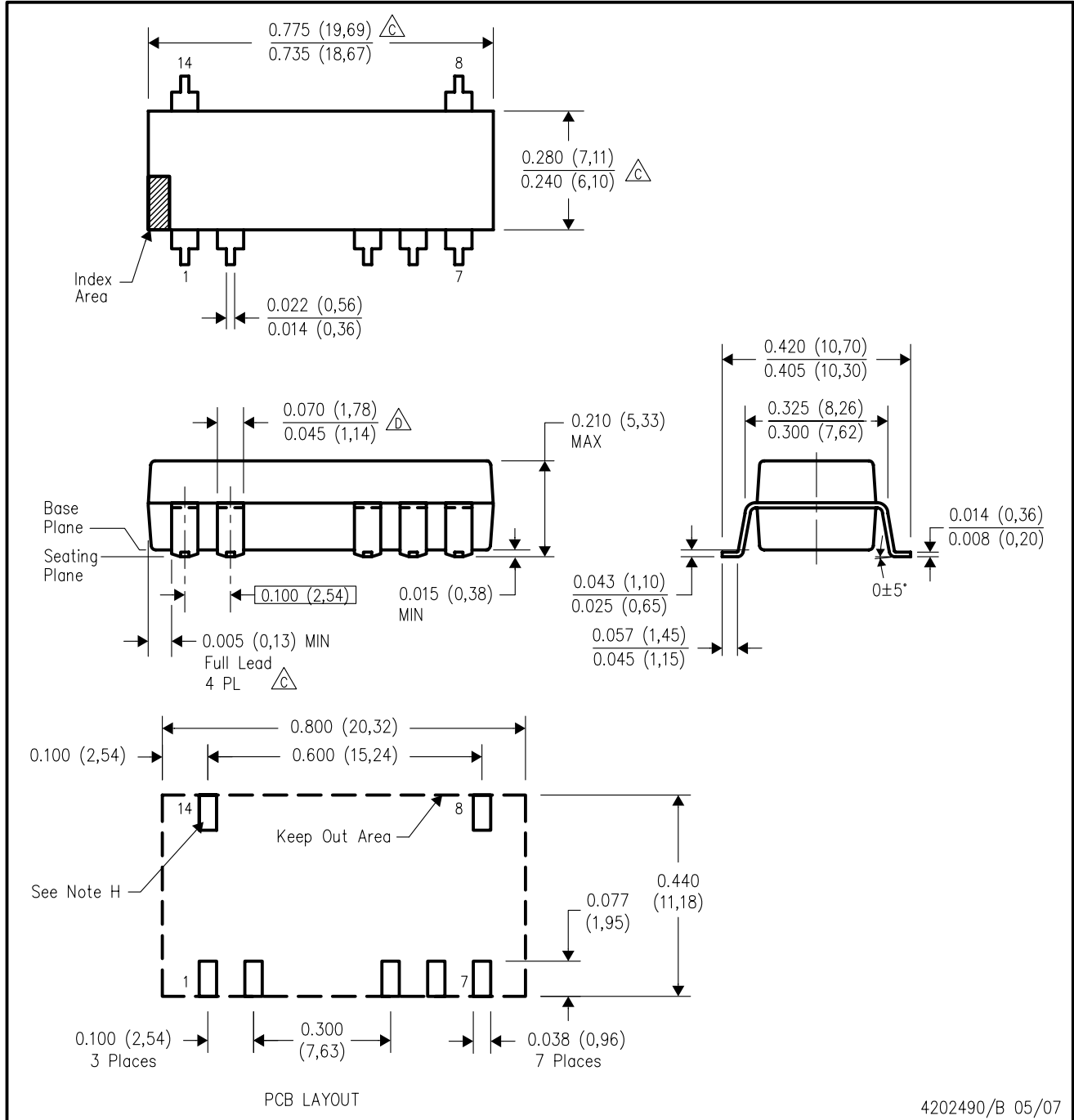

4202490/B 05/07

- NOTES:
- A. All linear dimensions are in inches (millimeters).
 - B. This drawing is subject to change without notice.
 - C. Dimensions do not include mold flash or protrusions. Mold flash or protrusions shall not exceed 0.010 (0,25).
 - D. Lead shoulder maximum dimension does not include dambar protrusions. Dambar protrusions shall not exceed 0.010 (0,25).
 - E. Distance between leads including dambar protrusions to be 0.005 (0,13) minimum.
 - F. A visual index feature must be located within the cross-hatched area.
 - G. For automatic insertion, any raised irregularity on the top surface (step, mesa, etc.) shall be symmetrical about the lateral and longitudinal package centerlines.
 - H. Power pin connections should be two or more vias per input, ground and output pin.

IMPORTANT NOTICE

Texas Instruments Incorporated (TI) reserves the right to make corrections, enhancements, improvements and other changes to its semiconductor products and services per JESD46, latest issue, and to discontinue any product or service per JESD48, latest issue. Buyers should obtain the latest relevant information before placing orders and should verify that such information is current and complete.

TI's published terms of sale for semiconductor products (<http://www.ti.com/sc/docs/stdterms.htm>) apply to the sale of packaged integrated circuit products that TI has qualified and released to market. Additional terms may apply to the use or sale of other types of TI products and services.

Reproduction of significant portions of TI information in TI data sheets is permissible only if reproduction is without alteration and is accompanied by all associated warranties, conditions, limitations, and notices. TI is not responsible or liable for such reproduced documentation. Information of third parties may be subject to additional restrictions. Resale of TI products or services with statements different from or beyond the parameters stated by TI for that product or service voids all express and any implied warranties for the associated TI product or service and is an unfair and deceptive business practice. TI is not responsible or liable for any such statements.

Buyers and others who are developing systems that incorporate TI products (collectively, "Designers") understand and agree that Designers remain responsible for using their independent analysis, evaluation and judgment in designing their applications and that Designers have full and exclusive responsibility to assure the safety of Designers' applications and compliance of their applications (and of all TI products used in or for Designers' applications) with all applicable regulations, laws and other applicable requirements. Designer represents that, with respect to their applications, Designer has all the necessary expertise to create and implement safeguards that (1) anticipate dangerous consequences of failures, (2) monitor failures and their consequences, and (3) lessen the likelihood of failures that might cause harm and take appropriate actions. Designer agrees that prior to using or distributing any applications that include TI products, Designer will thoroughly test such applications and the functionality of such TI products as used in such applications.

TI's provision of technical, application or other design advice, quality characterization, reliability data or other services or information, including, but not limited to, reference designs and materials relating to evaluation modules, (collectively, "TI Resources") are intended to assist designers who are developing applications that incorporate TI products; by downloading, accessing or using TI Resources in any way, Designer (individually or, if Designer is acting on behalf of a company, Designer's company) agrees to use any particular TI Resource solely for this purpose and subject to the terms of this Notice.

TI's provision of TI Resources does not expand or otherwise alter TI's applicable published warranties or warranty disclaimers for TI products, and no additional obligations or liabilities arise from TI providing such TI Resources. TI reserves the right to make corrections, enhancements, improvements and other changes to its TI Resources. TI has not conducted any testing other than that specifically described in the published documentation for a particular TI Resource.

Designer is authorized to use, copy and modify any individual TI Resource only in connection with the development of applications that include the TI product(s) identified in such TI Resource. NO OTHER LICENSE, EXPRESS OR IMPLIED, BY ESTOPPEL OR OTHERWISE TO ANY OTHER TI INTELLECTUAL PROPERTY RIGHT, AND NO LICENSE TO ANY TECHNOLOGY OR INTELLECTUAL PROPERTY RIGHT OF TI OR ANY THIRD PARTY IS GRANTED HEREIN, including but not limited to any patent right, copyright, mask work right, or other intellectual property right relating to any combination, machine, or process in which TI products or services are used. Information regarding or referencing third-party products or services does not constitute a license to use such products or services, or a warranty or endorsement thereof. Use of TI Resources may require a license from a third party under the patents or other intellectual property of the third party, or a license from TI under the patents or other intellectual property of TI.

TI RESOURCES ARE PROVIDED "AS IS" AND WITH ALL FAULTS. TI DISCLAIMS ALL OTHER WARRANTIES OR REPRESENTATIONS, EXPRESS OR IMPLIED, REGARDING RESOURCES OR USE THEREOF, INCLUDING BUT NOT LIMITED TO ACCURACY OR COMPLETENESS, TITLE, ANY EPIDEMIC FAILURE WARRANTY AND ANY IMPLIED WARRANTIES OF MERCHANTABILITY, FITNESS FOR A PARTICULAR PURPOSE, AND NON-INFRINGEMENT OF ANY THIRD PARTY INTELLECTUAL PROPERTY RIGHTS. TI SHALL NOT BE LIABLE FOR AND SHALL NOT DEFEND OR INDEMNIFY DESIGNER AGAINST ANY CLAIM, INCLUDING BUT NOT LIMITED TO ANY INFRINGEMENT CLAIM THAT RELATES TO OR IS BASED ON ANY COMBINATION OF PRODUCTS EVEN IF DESCRIBED IN TI RESOURCES OR OTHERWISE. IN NO EVENT SHALL TI BE LIABLE FOR ANY ACTUAL, DIRECT, SPECIAL, COLLATERAL, INDIRECT, PUNITIVE, INCIDENTAL, CONSEQUENTIAL OR EXEMPLARY DAMAGES IN CONNECTION WITH OR ARISING OUT OF TI RESOURCES OR USE THEREOF, AND REGARDLESS OF WHETHER TI HAS BEEN ADVISED OF THE POSSIBILITY OF SUCH DAMAGES.

Unless TI has explicitly designated an individual product as meeting the requirements of a particular industry standard (e.g., ISO/TS 16949 and ISO 26262), TI is not responsible for any failure to meet such industry standard requirements.

Where TI specifically promotes products as facilitating functional safety or as compliant with industry functional safety standards, such products are intended to help enable customers to design and create their own applications that meet applicable functional safety standards and requirements. Using products in an application does not by itself establish any safety features in the application. Designers must ensure compliance with safety-related requirements and standards applicable to their applications. Designer may not use any TI products in life-critical medical equipment unless authorized officers of the parties have executed a special contract specifically governing such use. Life-critical medical equipment is medical equipment where failure of such equipment would cause serious bodily injury or death (e.g., life support, pacemakers, defibrillators, heart pumps, neurostimulators, and implantables). Such equipment includes, without limitation, all medical devices identified by the U.S. Food and Drug Administration as Class III devices and equivalent classifications outside the U.S.

TI may expressly designate certain products as completing a particular qualification (e.g., Q100, Military Grade, or Enhanced Product). Designers agree that it has the necessary expertise to select the product with the appropriate qualification designation for their applications and that proper product selection is at Designers' own risk. Designers are solely responsible for compliance with all legal and regulatory requirements in connection with such selection.

Designer will fully indemnify TI and its representatives against any damages, costs, losses, and/or liabilities arising out of Designer's non-compliance with the terms and provisions of this Notice.

Looking for pricing, stock, or lifecycle information?

Click below to explore more details on WIN SOURCE:

 [View DCV010505P-U/700 on WIN SOURCE](#)

 [Texas Instruments](#) Information

Optimize Your Supply Chain with WIN SOURCE Solutions

-  Global Sourcing Solution
-  Obsolete Management
-  Cost Control Management
-  Shortage Management
-  Alternative Solution
-  Excess Inventory Management