



**THE DATASHEET OF
DRV8850RGYT**



DRV8850 Low-Voltage H-Bridge IC With LDO Voltage Regulator

1 Features

- H-Bridge Motor Driver
 - Drives a DC Motor, One Winding of a Stepper Motor, or Other Loads
 - Low MOSFET On-Resistance: 65 mΩ HS + LS at 4.2V, 25°C
- 5-A Continuous 8-A Peak-Drive Current
- Internal Current Sensing With Current Sense Output
- 2 to 5.5-V Operating Supply Voltage Range
- Overvoltage and Undervoltage Lockout
- Low-Power Sleep Mode
- 100-mA Isolated Low-Dropout (LDO) Voltage Regulator
- 24-Pin VQFN Package

2 Applications

- Battery-Operated Applications With High Start-Up Torque, such as:
 - Personal Hygiene (Electric Toothbrushes, Shavers)
 - Toys
 - RC Helicopters and Cars
 - Robotics

3 Description

The DRV8850 device provides a motor driver plus LDO voltage regulator solution for consumer products, toys, and other low-voltage or battery-powered motion-control applications. The device has one H-bridge driver to drive a DC motor, a voice-coil actuator, one winding of a stepper motor, a solenoid, or other devices. The output driver block consists of N-channel power MOSFETs configured as an H-bridge to drive the load. An internal charge pump generates the needed gate-drive voltages.

The DRV8850 device supplies up to 5 A of continuous output current (with proper PCB heat sinking) and up to 8-A peak current. It operates on a supply voltage from 2 V to 5.5 V.

A low-dropout linear voltage regulator is integrated with the motor driver to supply power to microcontrollers or other circuits. The LDO voltage regulator can be active in device sleep mode, so that the driver may be shut down without removing power to any devices powered by the LDO voltage regulator.

Internal shutdown functions provide overcurrent, short circuit, undervoltage, overvoltage, and overtemperature protection. In addition, the device also has built-in current sensing for accurate current measurement.

The DRV8850 device is packaged in a 24-pin VQFN (3.5-mm x 5.5-mm) package (Eco-friendly: RoHS and no Sb/Br).

Device Information⁽¹⁾

PART NUMBER	PACKAGE	BODY SIZE (NOM)
DRV8850	VQFN (24)	5.50 mm x 3.50 mm

(1) For all available packages, see the orderable addendum at the end of the data sheet.

Simplified Schematic

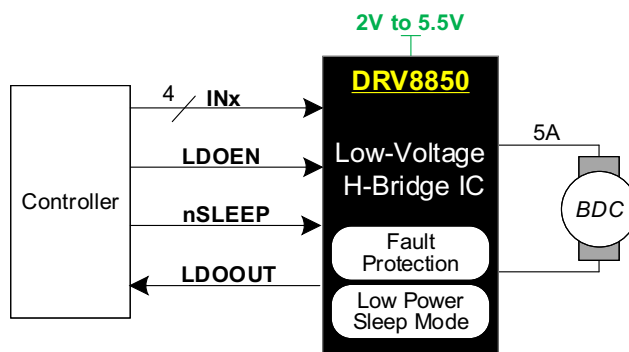

Table of Contents

1 Features	1	8 Application and Implementation	18
2 Applications	1	8.1 Application Information.....	18
3 Description	1	8.2 Typical Application	18
4 Revision History	2	9 Power Supply Recommendations	20
5 Pin Configuration and Functions	3	9.1 Bulk Capacitance	20
6 Specifications	4	10 Layout	20
6.1 Absolute Maximum Ratings	4	10.1 Layout Guidelines	20
6.2 ESD Ratings.....	4	10.2 Layout Example	21
6.3 Recommended Operating Conditions.....	4	10.3 Thermal Considerations	21
6.4 Thermal Information	4	11 Device and Documentation Support	22
6.5 Electrical Characteristics.....	5	11.1 Documentation Support	22
6.6 Timing Requirements	6	11.2 Receiving Notification of Documentation Updates	22
6.7 Typical Characteristics	7	11.3 Community Resources.....	22
7 Detailed Description	10	11.4 Trademarks	22
7.1 Overview	10	11.5 Electrostatic Discharge Caution.....	22
7.2 Functional Block Diagram	11	11.6 Glossary	22
7.3 Feature Description.....	12	12 Mechanical, Packaging, and Orderable	22
7.4 Device Functional Modes.....	17	Information	22

4 Revision History

NOTE: Page numbers for previous revisions may differ from page numbers in the current version.

Changes from Revision B (December 2015) to Revision C	Page
• Updated the RDS(ON) value and added the condition on the front page <i>Features</i> section	1
• Added maximum values for the HS and LS FET on resistance parameters (at $T_A = 25^\circ\text{C}$, 85°C) in the <i>Electrical Characteristics</i> table	5
• Added the <i>Documentation Support</i> and <i>Receiving Notification of Documentation Updates</i> sections	22

Changes from Revision A (January 2014) to Revision B	Page
• Added <i>Pin Configuration and Functions</i> section, <i>ESD Ratings</i> table, <i>Feature Description</i> section, <i>Device Functional Modes</i> , <i>Application and Implementation</i> section, <i>Power Supply Recommendations</i> section, <i>Layout</i> section, <i>Device and Documentation Support</i> section, and <i>Mechanical, Packaging, and Orderable Information</i> section	1
• Removed HTSSOP package.	1

Changes from Original (November 2013) to Revision A	Page
• Removed product preview banner.....	1

5 Pin Configuration and Functions

RGY Package
24-Pin VQFN With Exposed Thermal Pad
Top View

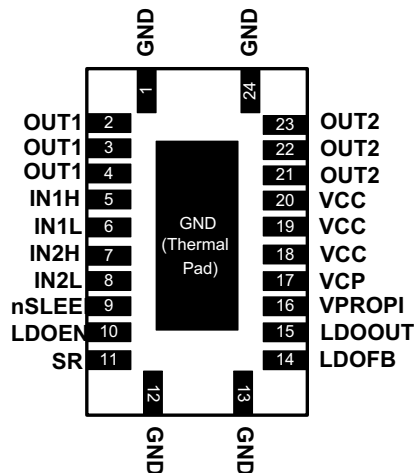

Pin Functions

PIN		I/O ⁽¹⁾	DESCRIPTION	EXTERNAL COMPONENTS OR CONNECTIONS
NAME	NO.			
POWER AND GROUND				
GND	1, 12, 13, 24, Thermal pad	—	Device ground	
LDOOUT	15	—	LDO regulator output	Bypass to GND with a 2.2- μ F 6.3-V ceramic capacitor
VCC	21, 22, 23	—	Device supply	Bypass to GND with 0.1- μ F and 10- μ F 6.3-V ceramic capacitors
VCP	17	—	Charge pump	Connect a 0.1- μ F 6.3-V ceramic capacitor to VCC
CONTROL				
IN1H	5	I	Input 1 HS FET enable	Active high enables HS FET for output 1 Internal pulldown resistor
IN1L	6	I	Input 1 LS FET enable	Active high enables LS FET for output 1 Internal pulldown resistor
IN2H	7	I	Input 2 HS FET enable	Active high enables HS FET for output 2 Internal pulldown resistor
IN2L	8	I	Input 2 LS FET enable	Active high enables LS FET for output 2 Internal pulldown resistor
LDOEN	10	I	LDO regulator enable	Logic low disables LDO regulator Logic high enables LDO regulator Internal pulldown resistor
LDOFB	14	I	LDO regulator feedback	Resistor divider from LDOOUT sets LDO output voltage May be connected to LDOIN to enable LDO
nSLEEP	9	I	Sleep mode input	Logic low puts device in low-power sleep mode Logic high for typical operation Internal pulldown resistor
SR	11	IO	Slew rate control	Resistor to ground sets output slew rate
OUTPUT				
OUT1	2, 3, 4	O	Output 1	Connect to motor winding
OUT2	18, 19, 20	O	Output 2	
VPROPI	16	O	Current sense output	Output current is proportional to H-bridge current. 1 k Ω , 1% resistor to GND for 2-A maximum current with VCC at 2 V. See Equation 1 if more current is required

(1) Directions: I = input, O = output, OZ = 3-state output, OD = open-drain output, IO = input or output

6 Specifications

6.1 Absolute Maximum Ratings

over operating free-air temperature range (unless otherwise noted)⁽¹⁾⁽²⁾

	MIN	MAX	UNIT
Power supply voltage, VCC	-0.3	7	V
Charge pump, VCP	-0.3	VCC + 7	V
Digital pin voltage, LDOEN, IN1H, IN1L, IN2H, IN2L, nSLEEP	-0.5	7	V
Other pins, OUT1, OUT2, SR, LDOOUT, LDOFB, VPROPI	-0.3	7	V
Peak motor drive output current, OUT1, OUT2	Internally Limited		A
LDO output current, LDOOUT	Internally Limited		A
T _J Operating junction temperature	-40	150	°C
T _{stg} Storage temperature	-60	150	°C

- (1) Stresses beyond those listed under *Absolute Maximum Ratings* may cause permanent damage to the device. These are stress ratings only, which do not imply functional operation of the device at these or any other conditions beyond those indicated under *Recommended Operating Conditions*. Exposure to absolute-maximum-rated conditions for extended periods may affect device reliability.
- (2) All voltage values are with respect to network ground terminal.

6.2 ESD Ratings

	VALUE	UNIT
V _(ESD) Electrostatic discharge	Human body model (HBM), per ANSI/ESDA/JEDEC JS-001 ⁽¹⁾	±4000
	Charged device model (CDM), per JEDEC specification JESD22-C101 ⁽²⁾	±1500

- (1) JEDEC document JEP155 states that 500-V HBM allows safe manufacturing with a standard ESD control process.
- (2) JEDEC document JEP157 states that 250-V CDM allows safe manufacturing with a standard ESD control process.

6.3 Recommended Operating Conditions

over operating free-air temperature range (unless otherwise noted)

	MIN	MAX	UNIT
VCC Device power supply voltage	2	5.5	V
V _{IN} Logic level input voltage	0	VCC	V
I _{OUT} H-bridge continuous output current ⁽¹⁾	0	5	A
I _{OUT} H-bridge peak output current ⁽¹⁾	0	8	A
f _{PWM} Externally applied PWM frequency	0	50	kHz
T _A Ambient temperature	-40	85	°C

- (1) Power dissipation and thermal limits must be observed

6.4 Thermal Information

THERMAL METRIC ⁽¹⁾	DRV8850	UNIT
	RGY (VQFN)	
	24 PINS	
R _{θJA} Junction-to-ambient thermal resistance	39.1	°C/W
R _{θJC(top)} Junction-to-case (top) thermal resistance	41.1	°C/W
R _{θJB} Junction-to-board thermal resistance	15	°C/W
ψ _{JT} Junction-to-top characterization parameter	0.6	°C/W
ψ _{JB} Junction-to-board characterization parameter	14.9	°C/W
R _{θJC(bot)} Junction-to-case (bottom) thermal resistance	3.2	°C/W

- (1) For more information about traditional and new thermal metrics, see the [Semiconductor and IC Package Thermal Metrics](#) application report.

6.5 Electrical Characteristics

 $T_A = 25^\circ\text{C}$, over recommended operating conditions unless otherwise noted

PARAMETER		TEST CONDITIONS	MIN	NOM	MAX	UNIT
POWER SUPPLIES (VCC)						
I_{VCC}	VCC operating supply current, LDO regulator and driver enabled	VCC = 4.2 V, nSLEEP = LDOEN = VCC		2.9		mA
I_{VCC1}	VCC sleep mode supply current	VCC = 4.2 V, nSLEEP = LDOEN = 0 V, INXH = INXL = 0 V			1	μA
I_{VCC2}	VCC operating supply current, LDO regulator enabled, driver disabled ⁽¹⁾	VCC = 4.2 V, nSLEEP = 0 V, LDOEN = VCC, INXH = INXL = 0 V		40		μA
I_{VCC3}	VCC operating supply current LDO voltage regulator disabled, driver enabled	VCC = 4.2 V, nSLEEP = VCC, LDOEN = 0 V		2.9		mA
V_{UVLO}	VCC undervoltage lockout voltage	VCC rising			2	V
		VCC falling			1.95	
V_{OVLO}	VCC overvoltage lockout voltage	VCC rising	5.6			V
		VCC falling	5.5			
LOGIC-LEVEL INPUTS (LDOEN, IN1H, IN1L, IN2H, IN2L, nSLEEP)						
V_{IL}	Input low voltage		0		$0.2 \times VCC$	V
V_{IH}	Input high voltage		$0.5 \times VCC$		VCC	V
V_{HYS}	Input hysteresis			$0.08 \times VCC$		V
I_{IL}	Input low current	$V_{IN} = 0$	-1		1	μA
I_{IH}	Input high current	$V_{IN} = 3.3\text{ V}$			50	μA
R_{PD}	Pulldown resistance	LDOEN		3.5		M Ω
		nSLEEP		400		k Ω
		INXH, INXL		200		k Ω
VPROPI OUTPUT (VPROPI)						
I_{VPROPI}	VPROPI output current	VCC = 4.2 V, resistor chosen to keep $V_{PROPI} \leq (VCC - 1\text{ V}) / I_{OUT}$ $500\text{ mA} \leq I_{OUT} \leq 5\text{ A}$		$I_{OUT} / 2000$		A
H-BRIDGE FETS (OUT1, OUT2)						
$R_{DS(ON)}$	HS FET on resistance	VCC = 4.2 V, $I_{OUT} = 2\text{ A}$, $T_A = 25^\circ\text{C}$		35	45	m Ω
		VCC = 4.2 V, $I_{OUT} = 2\text{ A}$, $T_A = 85^\circ\text{C}$				
	LS FET on resistance	VCC = 4.2 V, $I_{OUT} = 2\text{ A}$, $T_A = 25^\circ\text{C}$		30	40	m Ω
		VCC = 4.2 V, $I_{OUT} = 2\text{ A}$, $T_A = 85^\circ\text{C}$				
I_{OFF}	Off-state leakage current	VOUT = 0 V	-1		1	μA
LDO REGULATOR (LDOOUT)						
V_{FB}	LDO feedback (reference) voltage		0.76	0.8	0.84	V
V_{DO}	LDO regulator dropout voltage	VCC = 4.2 V, $I_{OUT} = 100\text{ mA}$, $T_A = 25^\circ\text{C}$		150		mV
		VCC = 4.2 V, $I_{OUT} = 100\text{ mA}$, $T_A = 85^\circ\text{C}$		175		mV
ΔV_{LINE}	LDO line regulation	VCC from 4.2 to 5.5 V, VOUT = 3.3 V	-2.5%		2.5%	
ΔV_{LOAD}	LDO load regulation	VOUT = 3.3 V, I_{OUT} from 1 to 100 mA	-2.5%		2.5%	
I_{CL}	LDO output current limit	VCC = 4.2 V, VOUT = 3.3 V, $T_A \geq 25^\circ\text{C}$		275		mA

(1) Does not include the current consumption from the feedback resistors.

Electrical Characteristics (continued)

 $T_A = 25^\circ\text{C}$, over recommended operating conditions unless otherwise noted

PARAMETER		TEST CONDITIONS	MIN	NOM	MAX	UNIT
PROTECTION CIRCUITS						
I_{OCP}	Overcurrent protection trip level	VCC = 2.5 to 5.5 V	9.5			A
t_{OCP}	Overcurrent protection deglitch time			1		μs
t_{RETRY}	Overcurrent retry time			4		ms
t_{TSD}	Thermal shutdown temperature	Die temperature (rising)	150	160	180	$^\circ\text{C}$
t_{HYS}	Thermal shutdown hysteresis	Temperature hysteresis		50		$^\circ\text{C}$

6.6 Timing Requirements

 $T_A = 25^\circ\text{C}$, VCC = 4.2 V, RL = 2 Ω ⁽¹⁾

			MIN	NOM	MAX	UNIT
t_R, t_F	Rise and fall time (measured at OUTx)	RSR connected to GND		70		ns
		RSR = 24 k Ω		0.7		μs
		RSR = 2.4 M Ω		70		μs
t_{DELAY}	Propagation delay (measured as time between input edge to output change)	RSR connected to GND		500		ns
		RSR = 24 k Ω		750		ns
		RSR = 2.4 M Ω		50		μs
t_{DEAD}	Dead time (measured as time OUTx FET is Hi-Z)	Low-side slow decay LS OFF to HS ON	RSR short to GND		400	ns
			RSR = 24 k Ω		2.6	μs
			RSR = 2.4 M Ω		110	μs
		Low-side slow decay HS OFF to LS ON	RSR short to GND		400	ns
			RSR = 24 k Ω		2.6	μs
			RSR = 2.4 M Ω		110	μs
		High-side slow decay or fast decay HS OFF to LS ON	RSR short to GND		400	ns
			RSR = 24 k Ω		2.6	μs
			RSR = 2.4 M Ω		110	μs
		High-side slow decay or fast decay LS OFF to HS ON	RSR short to GND		600	ns
			RSR = 24 k Ω		3.9	μs
			RSR = 2.4 M Ω		165	μs

(1) Rise and fall time measured from 10 to 90% VCC

6.7 Typical Characteristics

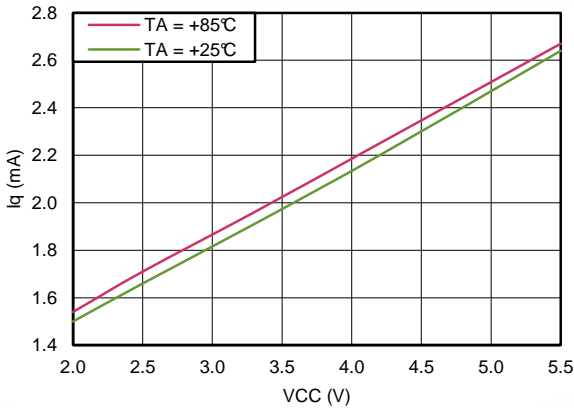

Figure 1. Quiescent Current With Motor Driver ON and LDO ON

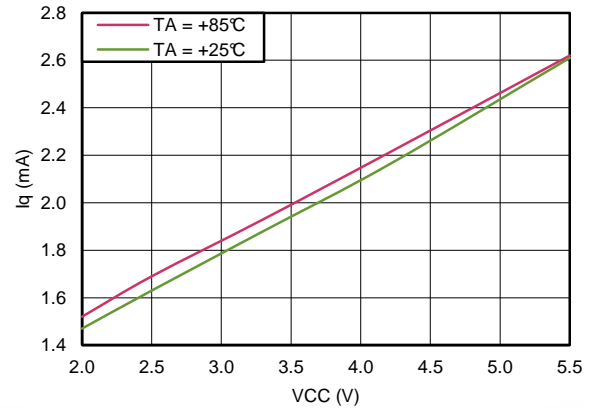

Figure 2. Quiescent Current With Motor Driver ON and LDO OFF

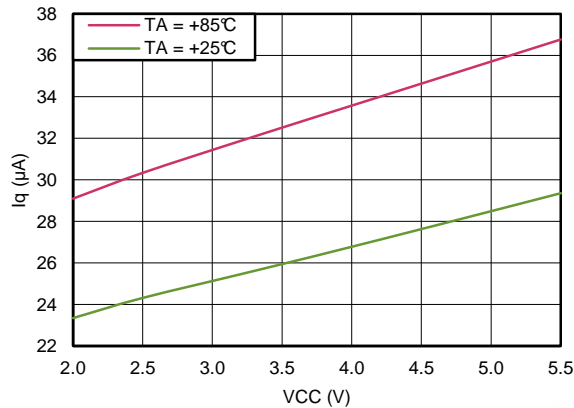

Figure 3. Quiescent Current With Motor Driver OFF and LDO ON

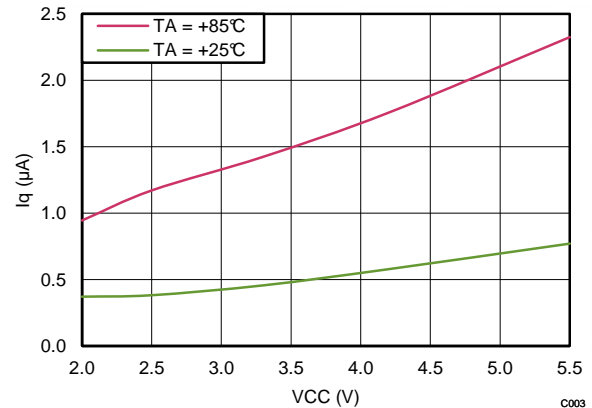

Figure 4. Quiescent Current With Motor Driver OFF and LDO OFF, Sleep Current

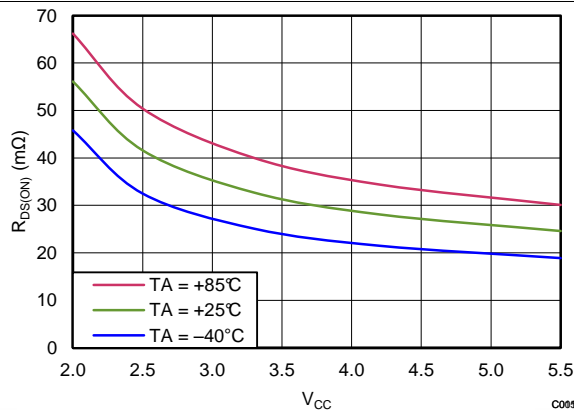

Figure 5. $R_{DS(ON)}$, HS – OUT1

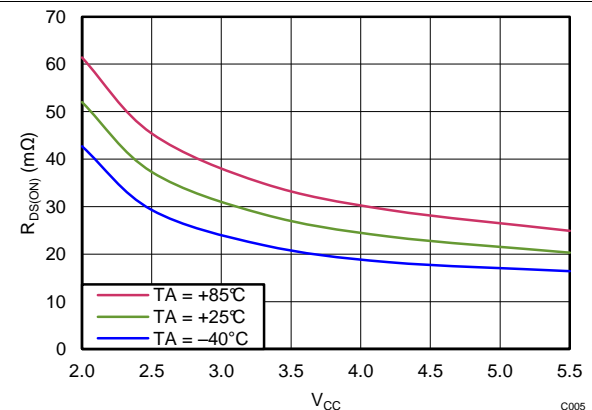
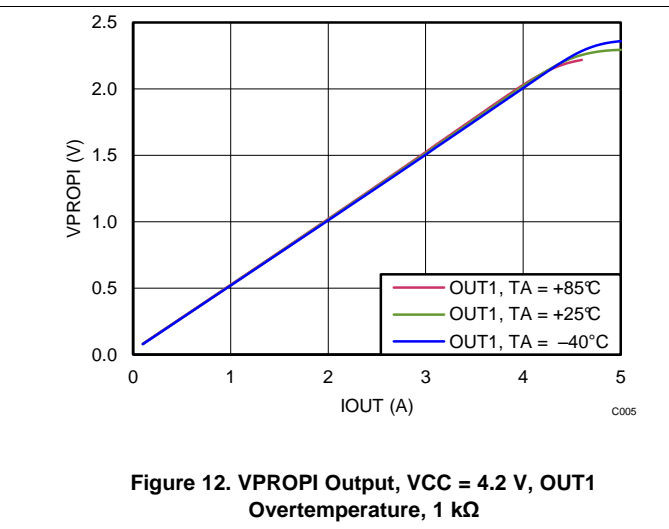
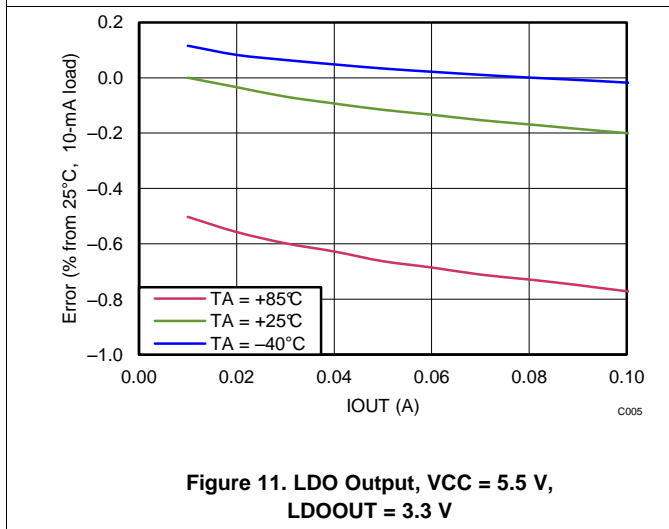
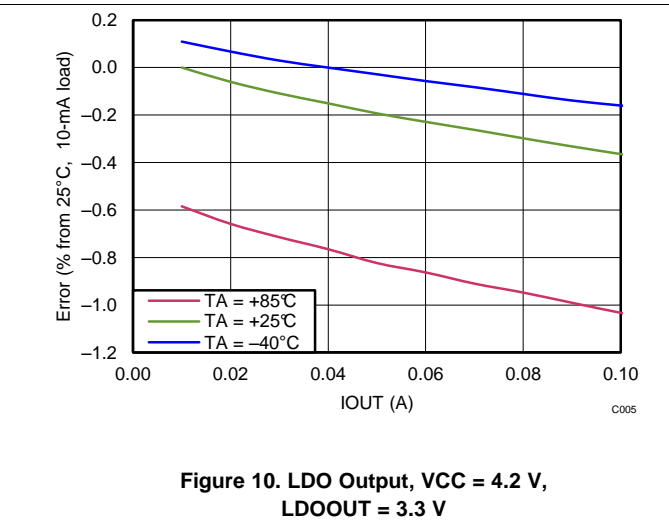
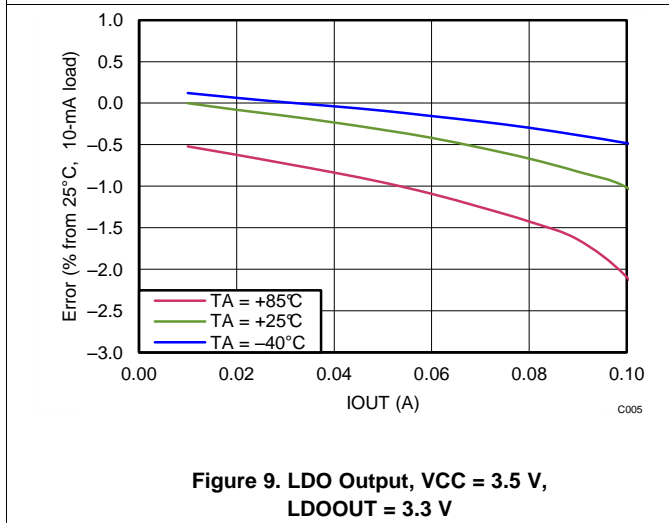
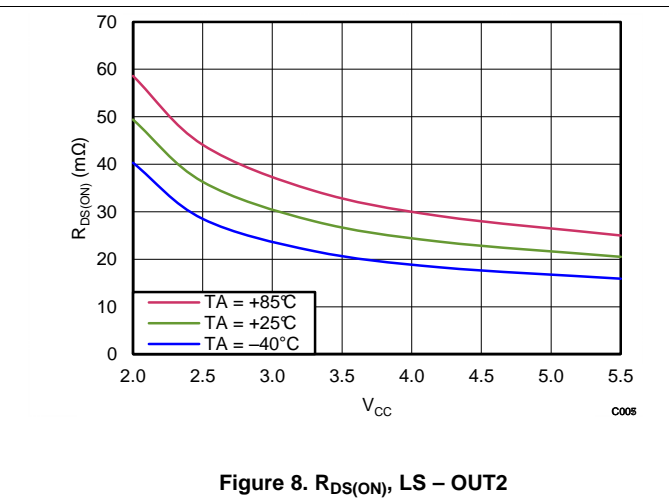
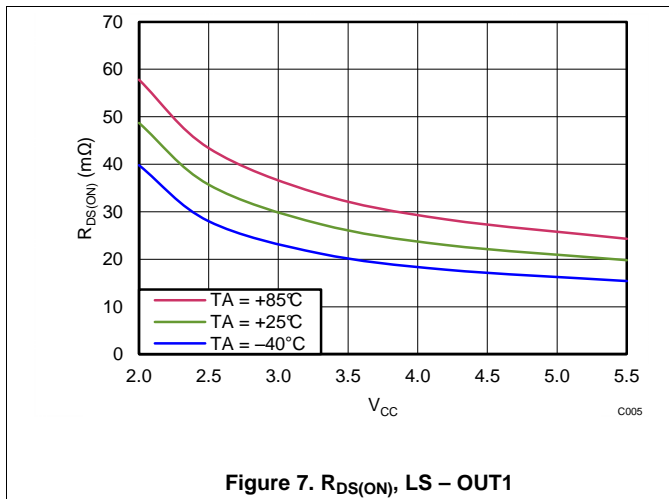

Figure 6. $R_{DS(ON)}$, HS – OUT2

Typical Characteristics (continued)



Typical Characteristics (continued)

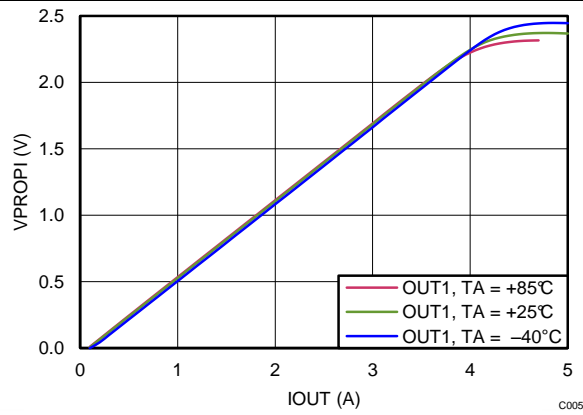

Figure 13. VPROPI Output, VCC = 4.2 V, OUT2 Overtemperature, 1 kΩ

7 Detailed Description

7.1 Overview

The DRV8850 is an integrated motor driver solution for one DC motor. The device integrates one NMOS H-bridge, current regulation circuitry, and various protection circuitry. The DRV8850 can be powered with a supply voltage range from 2 V to 5.5 V, and is capable of providing an output current up to 5-A peak current. Actual operable peak current will depend on the temperature, supply voltage, and PCB ground plane size. Between $V_M = 1.95\text{ V}$ and $V_M = 2\text{ V}$ the H-bridge outputs are shut down.

A simple 4 pin interface allows for individual control of each internal H-bridge FET. The condition where both HS and LS FETs are turned on at the same time is not allowed. During this input condition both the HS and LS FETs turn off.

The current monitoring is configurable from a range of 500 mA to 5 A. The VPROPI pin outputs an analog current that is proportional to the current flowing through the H-bridge. VPROPI is derived from the current through either of the high side FETs. Because of this, VPROPI does not represent H-bridge current when operating in a fast-decay mode or low-side slow-decay mode.

The LDO regulator integrated in the DRV8850 is typically used to provide the supply voltage for a low-power microcontroller. The output voltage is adjustable from 1.6 V to $V_{CC} - V_{LDO}$ using external resistors. LDOEN pin is used to enable or disable the LDO regulator; when disabled the output is turned off and the LDO regulator enters a very-low-power state.

7.3 Feature Description

Table 1 lists the external components.

Table 1. External Components

PIN		DESCRIPTION	
NAME	NO.		
LDOFB	14	LDO regulator feedback	Resistor divider from LDOOUT sets LDO output voltage.
LDOOUT	15	LDO regulator output	Bypass to GND with a 2.2- μ F 6.3-V ceramic capacitor.
SR	11	Slew rate control	Resistor to ground sets output slew rate GND to 2.4 M Ω .
VCC	21, 22, 23	Device supply	Bypass to GND with 0.1- μ F and 10- μ F 6.3-V ceramic capacitors.
VCP	17	Charge pump	Connect a 0.1- μ F 6.3-V ceramic capacitor to VCC
VPROPI	16	Current sense output	Output current is proportional to H-bridge current. 1 k Ω , 1% resistor to GND for 2-A max current with VCC at 2 V. See Equation 1 for if more current is required.

7.3.1 Power Supervisor

The LDO regulator can be active independent of the nSLEEP pin. This independence allows a microcontroller, or other device, to be powered by the LDO voltage regulator, while retaining the ability to put the DRV8850 device into sleep mode.

Because of this functionality, nSLEEP and LDOEN must both be brought logic low to minimize power consumption in sleep mode. If the LDO regulator remains active in sleep mode, a quiescent current of I_{VCO2} (typically 50 μ A plus current through the external feedback resistors) is drawn from the supply.

Table 2 lists the operation mode logic for the DRV8850 device.

Table 2. DRV8850 Device Operation Mode Logic⁽¹⁾

nSLEEP	LDOEN	LDO REGULATOR	DRIVER
0	0	Off	Sleep
0	1	Active	Sleep
1	0	Off	Active
1	1	Active	Active

(1) A state must be active for a minimum of 1 ms before a new state is commanded.

7.3.2 Bridge Control

A corresponding input pin controls the individual FETs in the DRV8850 device. Shoot-through (the condition when both HS and LS FETs are turned on at the same time) is not allowed; with this input condition, both the HS and LS FETs turn off.

Table 3 lists the logic for the DRV8850 device.

Table 3. DRV8850 Device Logic

INxL	INxH	OUTx
0	0	Z
0	1	H
1	0	L
1	1	Z

7.3.3 Current Sensing – VPROPI

The VPROPI pin outputs an analog current that is proportional to the current flowing in the H-bridge. The output current is typically 1 / 2000 of the current in both high side FETs. VPROPI is derived from the current through either of the high side FETs. Because of this, VPROPI does not represent the H-bridge current when operating in a fast-decay mode or low-side slow-decay mode. VPROPI represents the H-bridge current under forward drive, reverse drive, and high-side slow decay. VPROPI output is delayed by roughly 2 μs after the high side FET is switched on and it has reached approximately VCC (including the deglitch on the HSON). Select the external resistor so that the voltage on VPROPI is less than (VCC – 1 V), so the resistor must be sized less than:

$$2000 \times (VCC - 1 V) / I_{OUT} \tag{1}$$

where I_{OUT} is the maximum drive current to be monitored

The range of current that can be monitored is 500 mA to 5 A, assuming the external resistor meets [Equation 1](#).

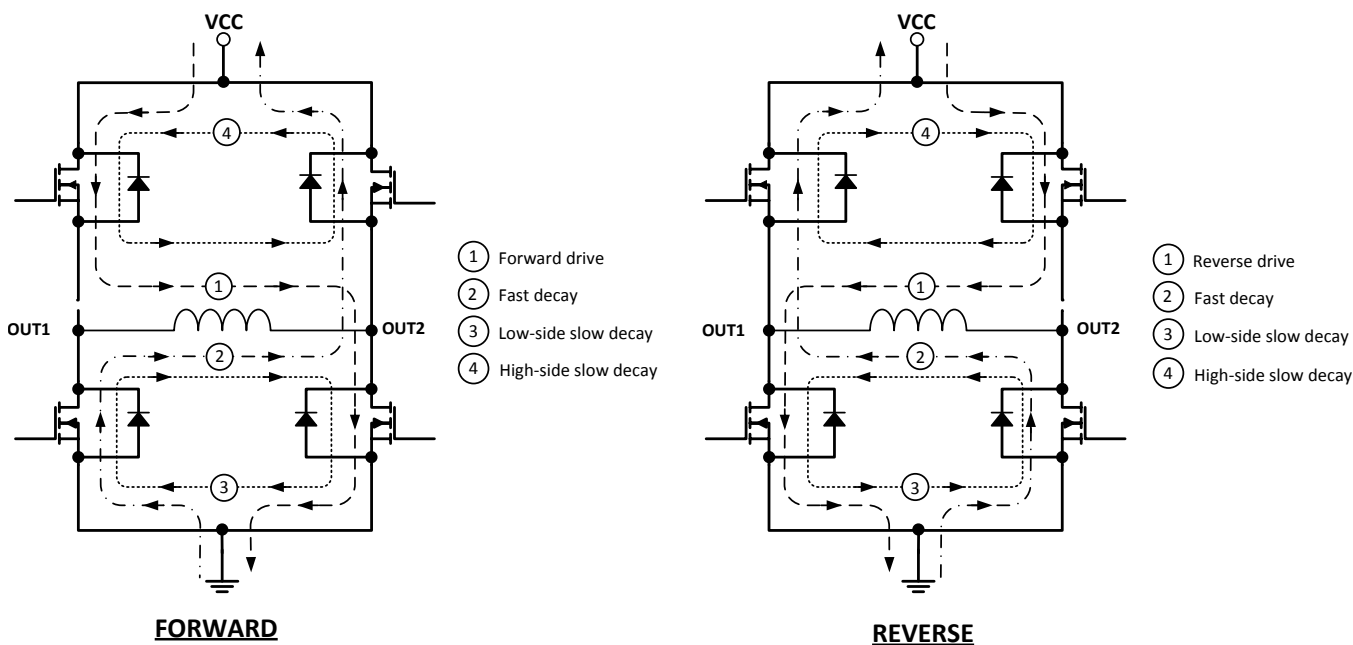

Figure 14. Forward and Reverse Operation

When using an independent half-bridge as a high-side driver, VPROPI does not output a current measurement during slow decay. During typical operation, VPROPI represents the total current flowing to loads connected to OUT1 and OUT2.

VPROPI is nonfunctional when implemented as a low-side driver.

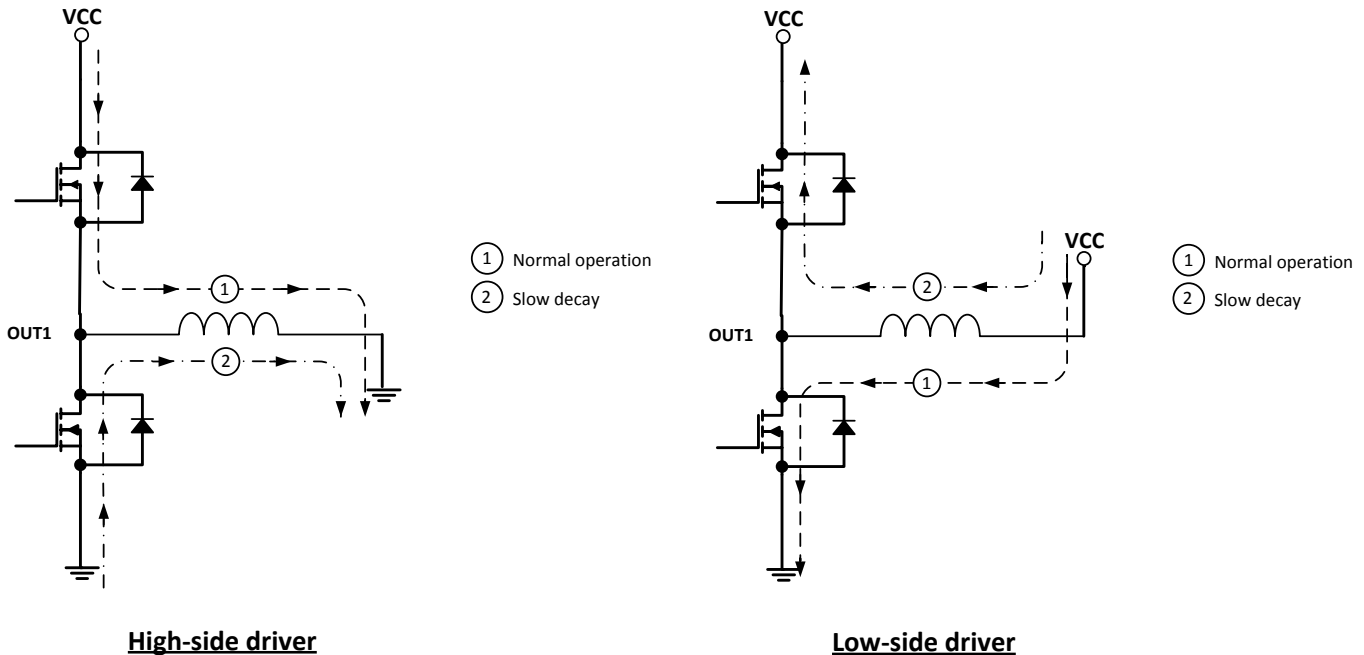

Figure 15. High-Side and Low-Side Drivers

7.3.4 Slew-Rate Control

The rise and fall times (t_R and t_F) of the outputs can be adjusted by the value of an external resistor connected from the SR pin to ground. The output slew rate is adjusted internally by the DRV8850 device by controlling the ramp rate of the driven FET gate.

The typical voltage on the SR pin is 0.6 V driven internally. Changing the resistor value monotonically increases the slew rates from approximately 100 ns to 100 μ s. Recommended values for the external resistor are from GND to 2.4 M Ω . If the SR pin is grounded then the slew rate is 100 ns.

7.3.5 Dead Time

The dead time (t_{DEAD}) is measured as the time when OUT_x is Hi-Z between turning off one of the H-bridge FETs and turning on the other. For example, the output is Hi-Z between turning off the high-side FET and turning on the low-side FET. When driving current out of the pin, the output is observed to fall to one diode drop below ground during dead time. When driving current into the pin, the output is observed to rise to one diode drop above VCC.

The DRV8850 has an analog dead time of approximately 100 ns. In addition to this analog dead time, the output is Hi-Z when the FET gate voltage is less than the threshold voltage. The total dead time depends on the SR resistor setting because a portion of the FET gate ramp includes the observable dead time.

7.3.6 Propagation Delay

The propagation delay time (t_{DELAY}) is measured as the time between an input edge to an output change. This time is composed of two parts: an input deglitcher and output slewing delay. The input deglitcher prevents noise on the input pins from affecting the output state.

The output slew rate also contributes to the delay time. For the output to change state during typical operation, first one FET must be turned off. The FET gate is ramped down according to the SR resistor selection, and the observed propagation delay ends when the FET gate falls to less than the threshold voltage.

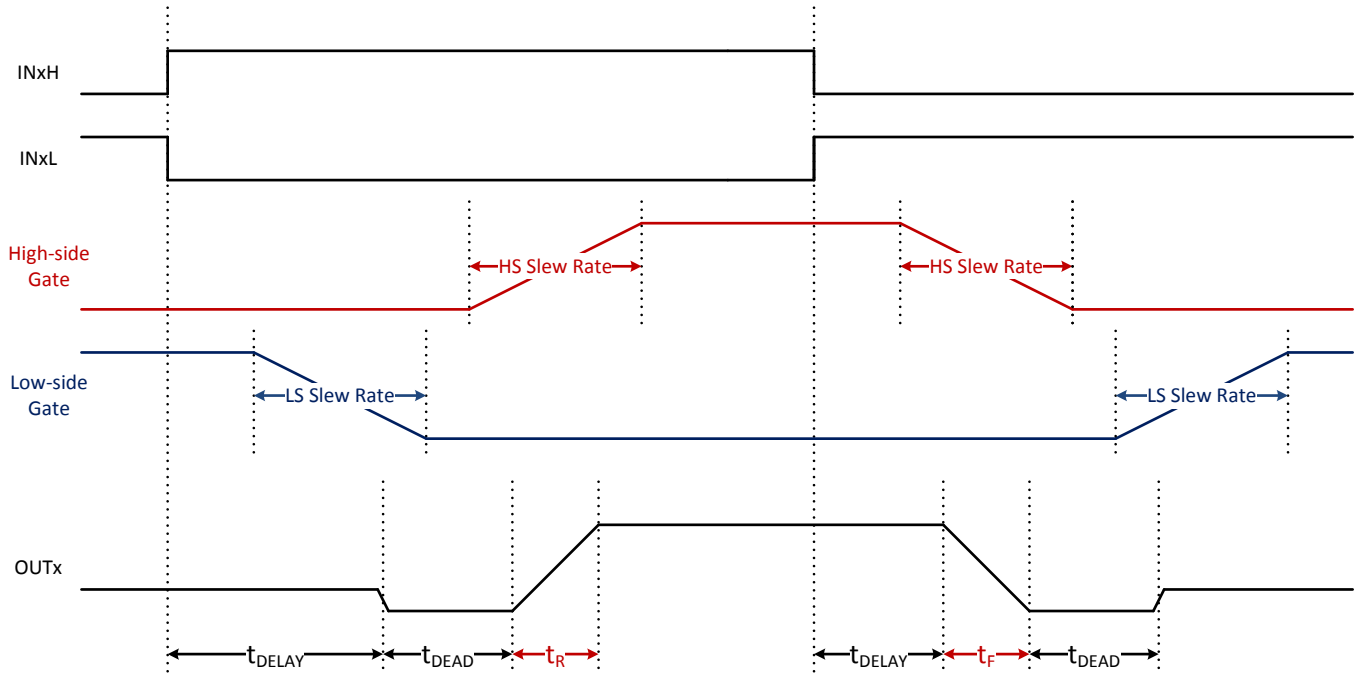

Figure 16. Low-Side Slow Decay Operation – Current Sourced from OUTx

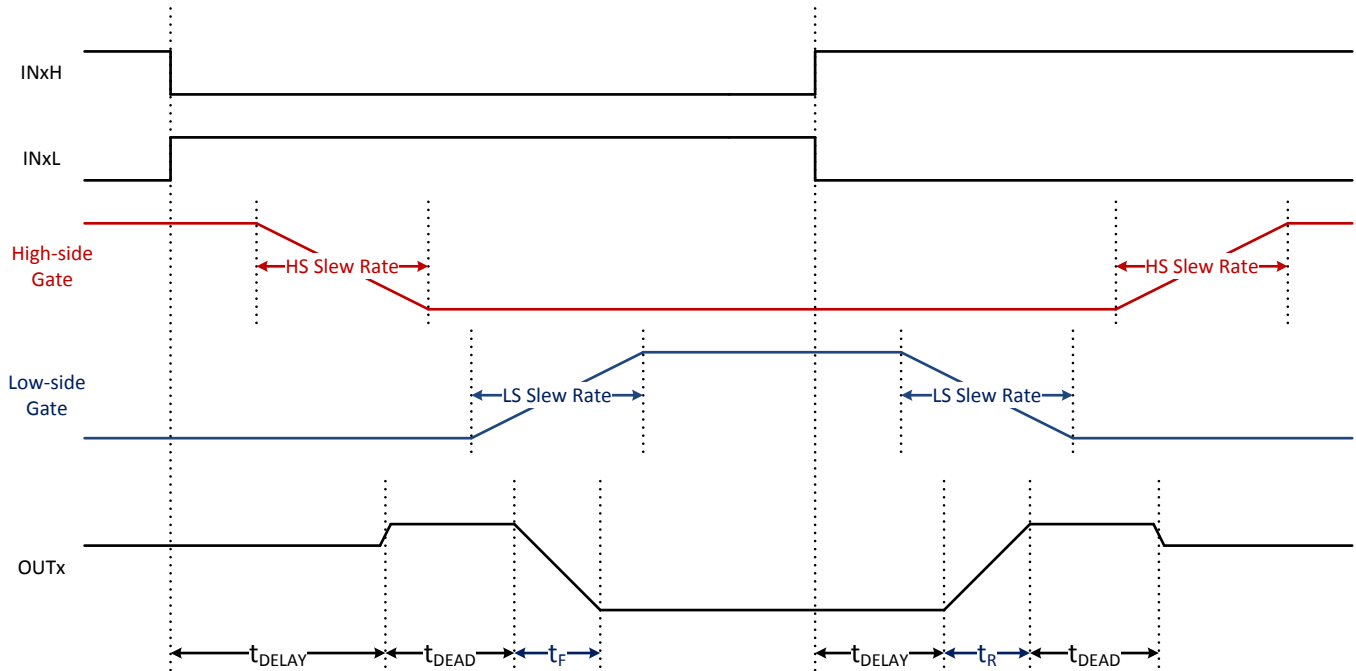

Figure 17. High-Side Slow Decay or Fast Decay Operation – Current Sunk into OUTx

7.3.7 Power Supplies and Input Pins

An internal charge pump generates a voltage greater than VCC that is used to drive the internal N-channel power MOSFETs. The charge pump requires a capacitor between the VCP and VCC pins. TI recommends bypassing VCC to ground with 0.1- μ F and 10- μ F ceramic capacitors, placing them as close as possible to the IC. Each input pin has a weak pull-down resistor to ground (see [Electrical Characteristics](#) for more details).

The input pins should not be driven to more than 0.6 V without the VCC power supply removed.

7.3.8 LDO Voltage Regulator

An LDO regulator is integrated into the DRV8850 device. The LDO regulator is typically used to provide the supply voltage for a low-power microcontroller. For proper operation, bypass the LDOOUT pin to GND using a ceramic capacitor. The recommended value for this component is 2.2 μ F.

Two external resistors are used to set the LDO voltage (V_{LDO}) by creating a voltage divider between LDOOUT and LDOFB. The LDO output voltage can be given by:

$$V_{LDO} = V_{FB} \times (1 + R1/R2)V$$

where

- R1 is located between LDOOUT and LDOFB
- R2 is between LDOFB and GND

(2)

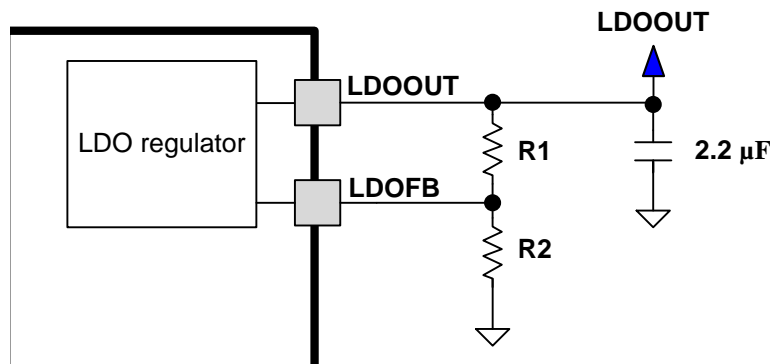

Figure 18. LDO Regulator Schematic

The output voltage is adjustable from 1.6 V to $V_{CC} - V_{LDO}$ using external resistors. The LDOEN pin is used to enable or disable the LDO regulator; when disabled, the output is turned off and the LDO regulator enters a very-low-power state.

When the LDO current load exceeds I_{CL} , the LDO regulator behaves like a constant current source. The LDO output voltage drops significantly with currents greater than I_{CL} .

7.3.9 Protection Circuits

The DRV8850 device is protected against undervoltage, overvoltage, overcurrent, and overtemperature events.

7.3.9.1 Overcurrent Protection (OCP)

An analog current limit circuit on each FET limits the current through the FET by removing the gate drive. If this analog current limit persists for longer than t_{OCP} , all FETs in the H-bridge are disabled. After approximately t_{RETRY} , the bridge reenables automatically.

Overcurrent conditions on both high and low-side devices, that is, a short to ground, supply, or across the motor winding result in an overcurrent shutdown.

7.3.9.2 Thermal Shutdown (TSD)

If the die temperature exceeds t_{TSD} , all FETs in the H-bridge are disabled. Once the die temperature has fallen below $t_{TSD} - t_{HYS}$, the H-bridge automatically reenables.

7.3.9.3 Undervoltage Lockout (UVLO)

If at any time the voltage on the VCC pins falls to less than the undervoltage lockout threshold voltage, all circuitry in the device is disabled and internal logic resets. Operation resumes when VCC rises to greater than the UVLO threshold.

7.3.9.4 Overvoltage Lockout (OVLO)

If at any time the voltage on the VCC pins rises to more than V_{OVLO} , the output FETs are disabled (outputs are high-Z). Operation resumes when VCC falls below the V_{OVLO} .

CAUTION

VCC must remain less than the absolute maximum rating for the device, or damage to the device may occur.

7.4 Device Functional Modes

The DRV8850 internal logic and charge pump are operating unless nSLEEP is pulled low. The LDO regulator can be active independent of the nSLEEP pin. This independence allows a microcontroller or other device to be powered by the LDO regulator while retaining the ability to put the DRV8850 into sleep mode.

If LDOEN and nSLEEP are both brought logic low the device will minimize current consumption in sleep mode. While the LDO regulator remains active in sleep mode, a quiescent current (typically 50 μ A plus current through the external feedback resistors) is drawn from the supply.

Each FET inside the device is controlled by a corresponding input pin on the DRV8850. The condition where both HS and LS FETs are turned on at the same time is not allowed. During this input condition both the HS and LS FETs turn off.

8 Application and Implementation

NOTE

Information in the following applications sections is not part of the TI component specification, and TI does not warrant its accuracy or completeness. TI's customers are responsible for determining suitability of components for their purposes. Customers should validate and test their design implementation to confirm system functionality.

8.1 Application Information

The DRV8850 can be used to drive a DC motor.

8.2 Typical Application

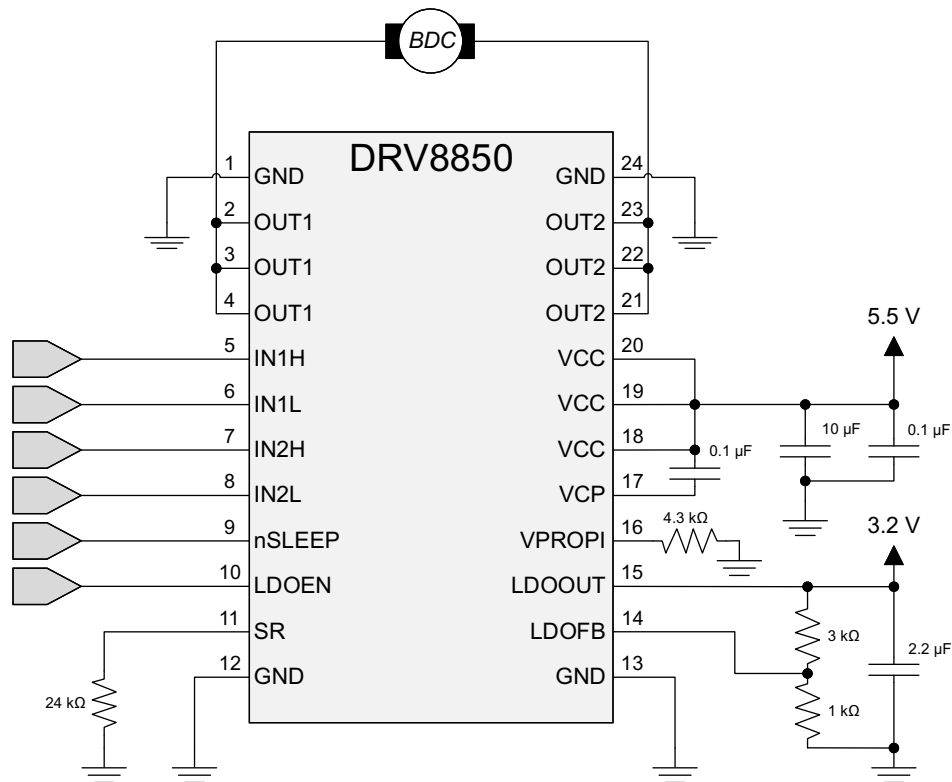

8.2.1 Design Requirements

Table 4 lists the parameters for this design example.

Table 4. Design Parameters

DESIGN PARAMETER	REFERENCE	EXAMPLE VALUE
Supply voltage	V_M	5.5 V
LDO output voltage	V_{LDO}	3.2 V
Slew rate	SR	700 ns
HS FET on resistance	$R_{DS(ON)_HS}$	35 mΩ
LS FET on resistance	$R_{DS(ON)_LS}$	30 mΩ
Motor rated current	I_M	2 A

8.2.2 Detailed Design Procedure

8.2.2.1 Motor Voltage

The motor voltage to use will depend on the ratings of the motor selected and the desired RPM. A higher voltage spins a brushed DC motor faster with the same PWM duty cycle applied to the power FETs. A higher voltage also increases the rate of current change through the inductive motor windings.

8.2.2.2 Drive Current

The current path is through the high-side sourcing DMOS power driver, motor winding, and low-side sinking DMOS power driver. Power dissipation losses in one source and sink DMOS power driver are shown in the following equation.

$$P_D = I^2 (R_{DS(ON)_{HS}} + R_{DS(ON)_{LS}}) \tag{3}$$

The DRV8850 has been measured to be capable of 5-A RMS current at 25°C on standard FR-4 PCBs. The maximum RMS current varies based on PCB design and the ambient temperature.

8.2.3 Application Curves

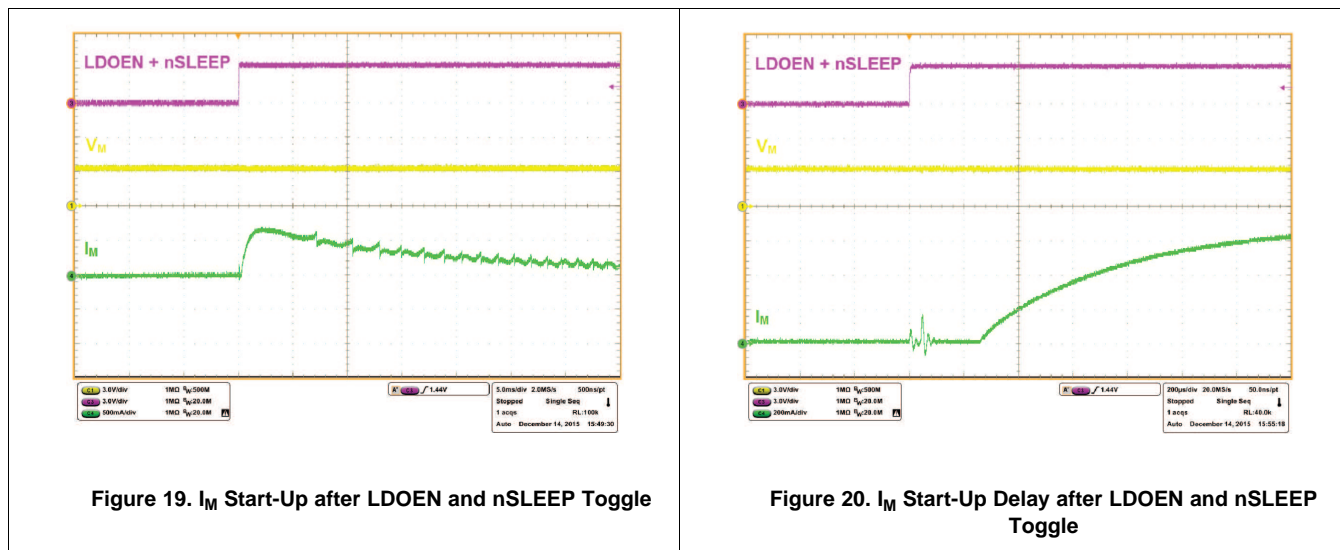

Figure 19. I_M Start-Up after LDOEN and nSLEEP Toggle

Figure 20. I_M Start-Up Delay after LDOEN and nSLEEP Toggle

9 Power Supply Recommendations

9.1 Bulk Capacitance

Having appropriate local bulk capacitance is an important factor in motor drive system design. It is generally beneficial to have more bulk capacitance, while the disadvantages are increased cost and physical size.

The amount of local capacitance needed depends on a variety of factors, including:

- The highest current required by the motor system.
- The power supply's capacitance and ability to source current.
- The amount of parasitic inductance between the power supply and motor system.
- The acceptable voltage ripple.
- The type of motor used (Brushed DC, Brushless DC, Stepper).
- The motor braking method.

The inductance between the power supply and motor drive system will limit the rate current can change from the power supply. If the local bulk capacitance is too small, the system will respond to excessive current demands or dumps from the motor with a change in voltage. When adequate bulk capacitance is used, the motor voltage remains stable and high current can be quickly supplied.

The data sheet generally provides a recommended value, but system-level testing is required to determine the appropriate sized bulk capacitor.

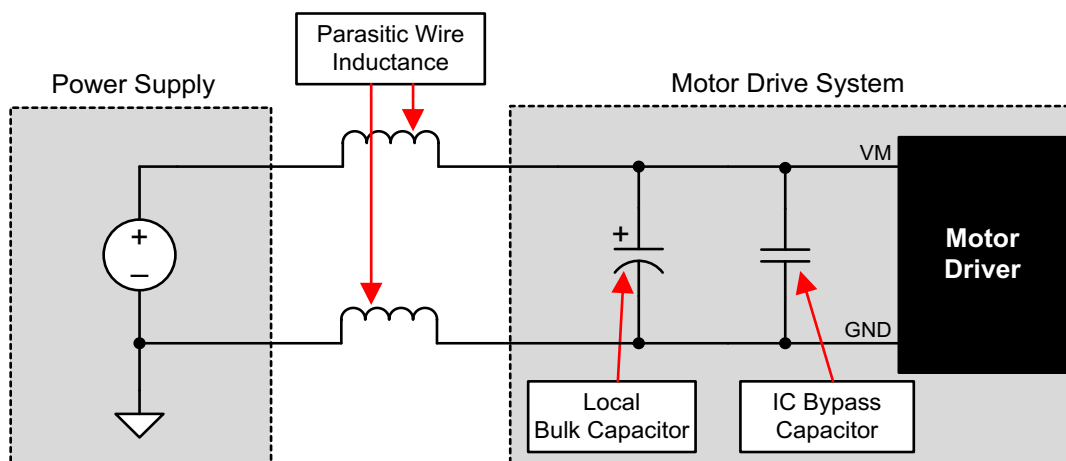

Figure 21. Example Setup of Motor Drive System With External Power Supply

The voltage rating for bulk capacitors should be higher than the operating voltage, to provide margin for cases when the motor transfers energy to the supply.

10 Layout

10.1 Layout Guidelines

- The bulk capacitor should be placed to minimize the distance of the high-current path through the motor driver device. The connecting metal trace widths should be as wide as possible, and numerous vias should be used when connecting PCB layers. These practices minimize inductance and allow the bulk capacitor to deliver high current.
- Small-value capacitors should be ceramic, and placed close to the device pins.
- The high-current device outputs should use wide metal traces.
- The device thermal pad should be soldered to the PCB top-layer ground plane. Multiple vias should be used to connect to a large bottom-layer ground plane. The use of large metal planes and multiple vias help dissipate the $I^2 \times R_{DS(on)}$ heat that is generated in the device.

10.2 Layout Example

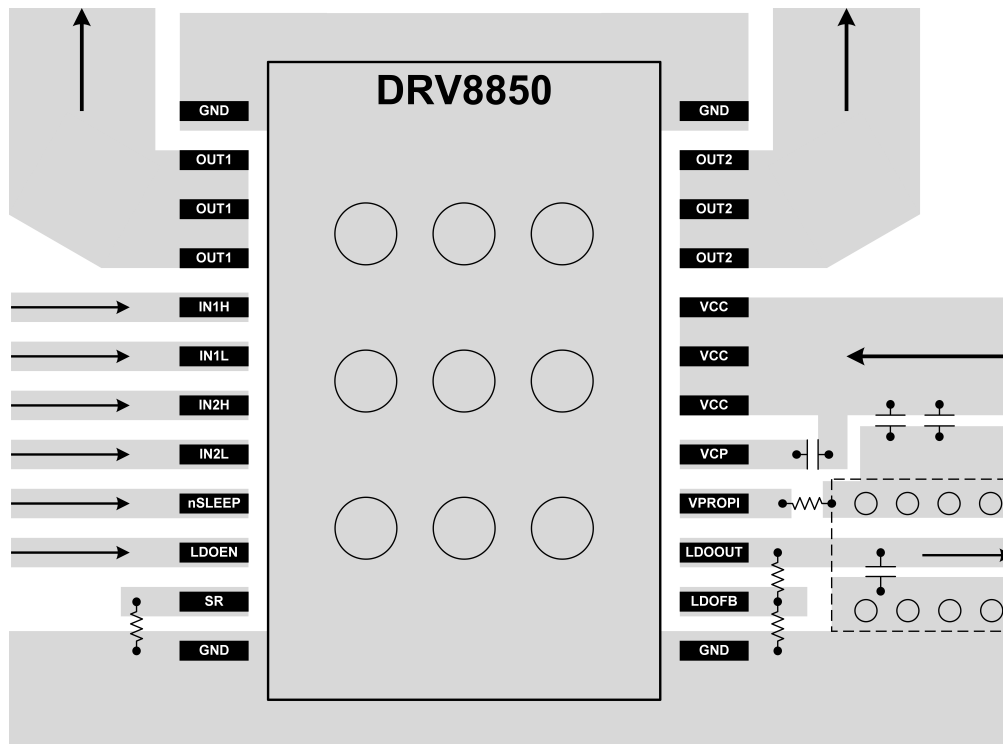

Figure 22. Layout Recommendation

10.3 Thermal Considerations

The DRV8850 device has thermal shutdown (TSD) as described in the [Thermal Shutdown \(TSD\)](#) section. If the die temperature exceeds approximately t_{TSD} , the device will be disabled until the temperature drops to a safe level.

Any tendency of the device to enter thermal shutdown is an indication of either excessive power dissipation, insufficient heatsinking, or too high an ambient temperature.

10.3.1 Power Dissipation

Power dissipation in the DRV8850 device is the sum of the motor driver power dissipation and the LDO voltage regulator dissipation.

The LDO dissipation is calculated simply by $(V_{IN} - V_{OUT}) \times I_{OUT}$.

The power dissipation in the motor driver is dominated by the power dissipated in the output FET resistance, or $R_{DS(ON)}$. Power dissipation can be estimated by:

$$P_{TOT} = (LS_{-}R_{DS(ON)} + HS_{-}R_{DS(ON)}) \times (I_{OUT(RMS)})^2$$

where

- P_{TOT} is the total power dissipation
 - $R_{DS(ON)}$ is the resistance of each FET
 - $I_{OUT(RMS)}$ is the RMS output current being driven
- (4)

The maximum amount of power that can be dissipated in the device is dependent on ambient temperature and heat sinking.

Note that $R_{DS(ON)}$ increases with temperature, so as the device heats, the power dissipation increases.

11 Device and Documentation Support

11.1 Documentation Support

11.1.1 Related Documentation

For related documentation see the following:

[DRV8850EVM User's Guide](#)

11.2 Receiving Notification of Documentation Updates

To receive notification of documentation updates, navigate to the device product folder on ti.com. In the upper right corner, click on *Alert me* to register and receive a weekly digest of any product information that has changed. For change details, review the revision history included in any revised document.

11.3 Community Resources

The following links connect to TI community resources. Linked contents are provided "AS IS" by the respective contributors. They do not constitute TI specifications and do not necessarily reflect TI's views; see TI's [Terms of Use](#).

TI E2E™ Online Community *TI's Engineer-to-Engineer (E2E) Community*. Created to foster collaboration among engineers. At e2e.ti.com, you can ask questions, share knowledge, explore ideas and help solve problems with fellow engineers.

Design Support *TI's Design Support* Quickly find helpful E2E forums along with design support tools and contact information for technical support.

11.4 Trademarks

E2E is a trademark of Texas Instruments.
All other trademarks are the property of their respective owners.

11.5 Electrostatic Discharge Caution



These devices have limited built-in ESD protection. The leads should be shorted together or the device placed in conductive foam during storage or handling to prevent electrostatic damage to the MOS gates.

11.6 Glossary

[SLYZ022](#) — *TI Glossary*.

This glossary lists and explains terms, acronyms, and definitions.

12 Mechanical, Packaging, and Orderable Information

The following pages include mechanical, packaging, and orderable information. This information is the most current data available for the designated devices. This data is subject to change without notice and revision of this document. For browser-based versions of this data sheet, refer to the left-hand navigation.

PACKAGING INFORMATION

Orderable Device	Status (1)	Package Type	Package Drawing	Pins	Package Qty	Eco Plan (2)	Lead/Ball Finish (6)	MSL Peak Temp (3)	Op Temp (°C)	Device Marking (4/5)	Samples
DRV8850RGYR	ACTIVE	VQFN	RGY	24	3000	Green (RoHS & no Sb/Br)	CU NIPDAU	Level-2-260C-1 YEAR	-40 to 85	DRV8850	Samples
DRV8850RGYT	ACTIVE	VQFN	RGY	24	250	Green (RoHS & no Sb/Br)	CU NIPDAU	Level-2-260C-1 YEAR	-40 to 85	DRV8850	Samples

(1) The marketing status values are defined as follows:

ACTIVE: Product device recommended for new designs.

LIFEBUY: TI has announced that the device will be discontinued, and a lifetime-buy period is in effect.

NRND: Not recommended for new designs. Device is in production to support existing customers, but TI does not recommend using this part in a new design.

PREVIEW: Device has been announced but is not in production. Samples may or may not be available.

OBSELETE: TI has discontinued the production of the device.

(2) Eco Plan - The planned eco-friendly classification: Pb-Free (RoHS), Pb-Free (RoHS Exempt), or Green (RoHS & no Sb/Br) - please check <http://www.ti.com/productcontent> for the latest availability information and additional product content details.

TBD: The Pb-Free/Green conversion plan has not been defined.

Pb-Free (RoHS): TI's terms "Lead-Free" or "Pb-Free" mean semiconductor products that are compatible with the current RoHS requirements for all 6 substances, including the requirement that lead not exceed 0.1% by weight in homogeneous materials. Where designed to be soldered at high temperatures, TI Pb-Free products are suitable for use in specified lead-free processes.

Pb-Free (RoHS Exempt): This component has a RoHS exemption for either 1) lead-based flip-chip solder bumps used between the die and package, or 2) lead-based die adhesive used between the die and leadframe. The component is otherwise considered Pb-Free (RoHS compatible) as defined above.

Green (RoHS & no Sb/Br): TI defines "Green" to mean Pb-Free (RoHS compatible), and free of Bromine (Br) and Antimony (Sb) based flame retardants (Br or Sb do not exceed 0.1% by weight in homogeneous material)

(3) MSL, Peak Temp. - The Moisture Sensitivity Level rating according to the JEDEC industry standard classifications, and peak solder temperature.

(4) There may be additional marking, which relates to the logo, the lot trace code information, or the environmental category on the device.

(5) Multiple Device Markings will be inside parentheses. Only one Device Marking contained in parentheses and separated by a "~" will appear on a device. If a line is indented then it is a continuation of the previous line and the two combined represent the entire Device Marking for that device.

(6) Lead/Ball Finish - Orderable Devices may have multiple material finish options. Finish options are separated by a vertical ruled line. Lead/Ball Finish values may wrap to two lines if the finish value exceeds the maximum column width.

Important Information and Disclaimer:The information provided on this page represents TI's knowledge and belief as of the date that it is provided. TI bases its knowledge and belief on information provided by third parties, and makes no representation or warranty as to the accuracy of such information. Efforts are underway to better integrate information from third parties. TI has taken and continues to take reasonable steps to provide representative and accurate information but may not have conducted destructive testing or chemical analysis on incoming materials and chemicals. TI and TI suppliers consider certain information to be proprietary, and thus CAS numbers and other limited information may not be available for release.

In no event shall TI's liability arising out of such information exceed the total purchase price of the TI part(s) at issue in this document sold by TI to Customer on an annual basis.

TAPE AND REEL INFORMATION



QUADRANT ASSIGNMENTS FOR PIN 1 ORIENTATION IN TAPE



*All dimensions are nominal

Device	Package Type	Package Drawing	Pins	SPQ	Reel Diameter (mm)	Reel Width W1 (mm)	A0 (mm)	B0 (mm)	K0 (mm)	P1 (mm)	W (mm)	Pin1 Quadrant
DRV8850RGYR	VQFN	RGY	24	3000	330.0	12.4	3.8	5.8	1.2	8.0	12.0	Q1
DRV8850RGYT	VQFN	RGY	24	250	180.0	12.4	3.8	5.8	1.2	8.0	12.0	Q1

TAPE AND REEL BOX DIMENSIONS

*All dimensions are nominal

Device	Package Type	Package Drawing	Pins	SPQ	Length (mm)	Width (mm)	Height (mm)
DRV8850RGYR	VQFN	RGY	24	3000	367.0	367.0	35.0
DRV8850RGYT	VQFN	RGY	24	250	210.0	185.0	35.0

GENERIC PACKAGE VIEW

RGY 24

VQFN - 1 mm max height

5.5 x 3.5 mm, 0.5 mm pitch

PLASTIC QUAD FLATPACK - NO LEAD

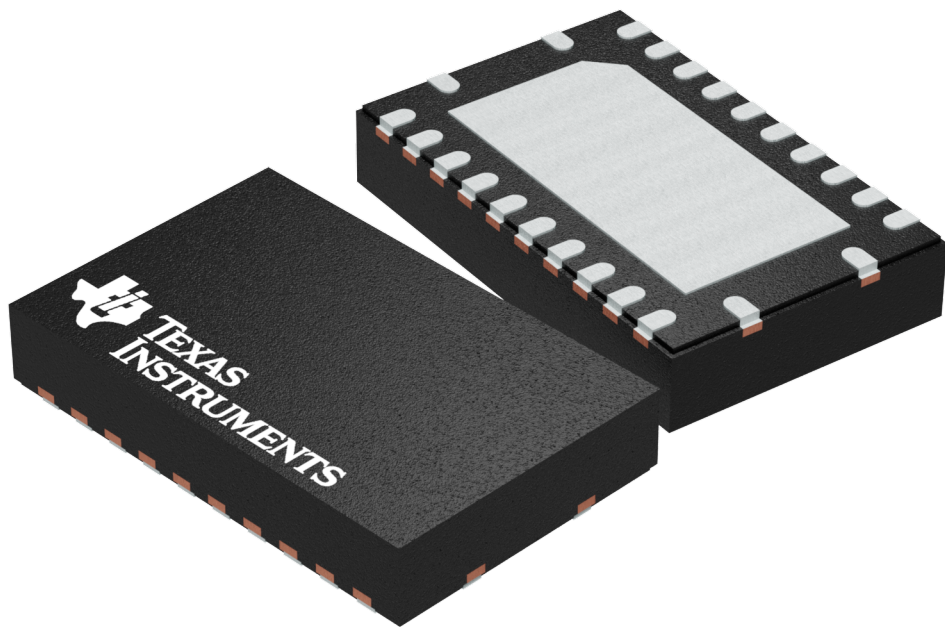

Images above are just a representation of the package family, actual package may vary.
Refer to the product data sheet for package details.

4203539-5/J

RGY (R-PVQFN-N24)

PLASTIC QUAD FLATPACK NO-LEAD

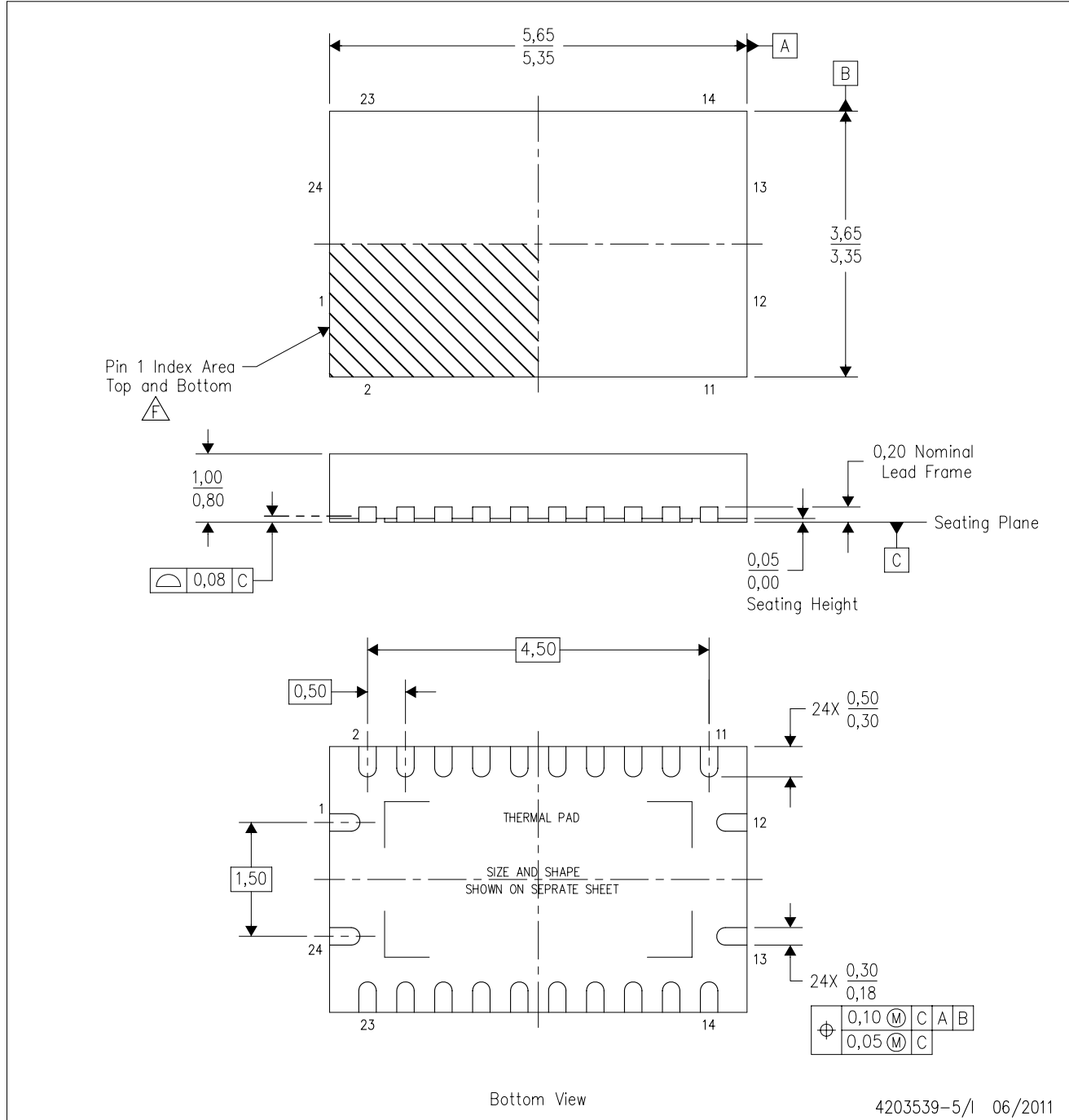

- NOTES:
- All linear dimensions are in millimeters. Dimensioning and tolerancing per ASME Y14.5M-1994.
 - This drawing is subject to change without notice.
 - QFN (Quad Flatpack No-Lead) package configuration.
 - The package thermal pad must be soldered to the board for thermal and mechanical performance.
 - See the additional figure in the Product Data Sheet for details regarding the exposed thermal pad features and dimensions.
- ⚠ Pin 1 identifiers are located on both top and bottom of the package and within the zone indicated. The Pin 1 identifiers are either a molded, marked, or metal feature.
- Package complies to JEDEC MO-241 variation BA.

RGY (R-PVQFN-N24)

PLASTIC QUAD FLATPACK NO-LEAD

THERMAL INFORMATION

This package incorporates an exposed thermal pad that is designed to be attached directly to an external heatsink. The thermal pad must be soldered directly to the printed circuit board (PCB). After soldering, the PCB can be used as a heatsink. In addition, through the use of thermal vias, the thermal pad can be attached directly to the appropriate copper plane shown in the electrical schematic for the device, or alternatively, can be attached to a special heatsink structure designed into the PCB. This design optimizes the heat transfer from the integrated circuit (IC).

For information on the Quad Flatpack No-Lead (QFN) package and its advantages, refer to Application Report, QFN/SON PCB Attachment, Texas Instruments Literature No. SLUA271. This document is available at www.ti.com.

The exposed thermal pad dimensions for this package are shown in the following illustration.

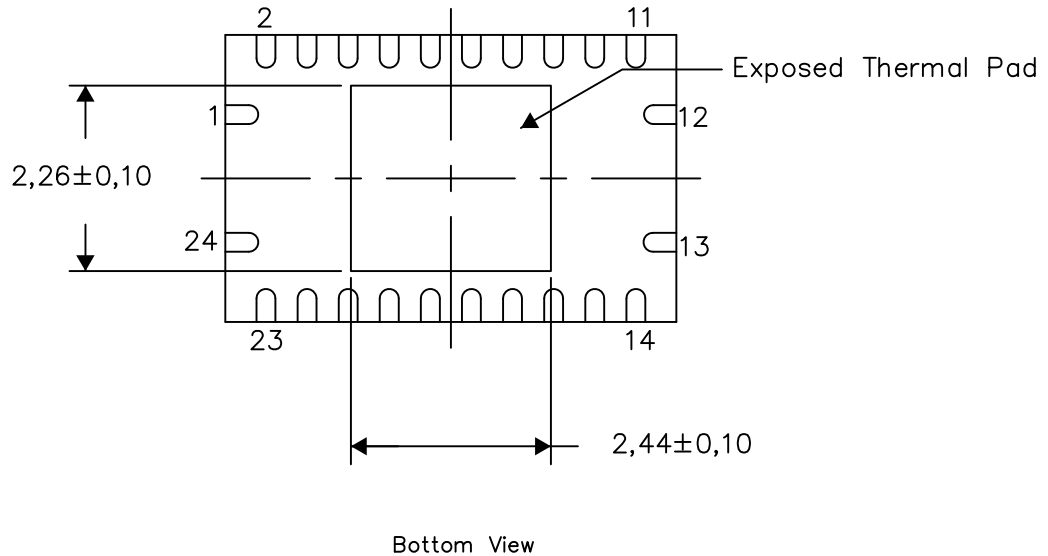

Exposed Thermal Pad Dimensions

4206353-7/P 03/14

NOTE: All linear dimensions are in millimeters

IMPORTANT NOTICE

Texas Instruments Incorporated (TI) reserves the right to make corrections, enhancements, improvements and other changes to its semiconductor products and services per JESD46, latest issue, and to discontinue any product or service per JESD48, latest issue. Buyers should obtain the latest relevant information before placing orders and should verify that such information is current and complete.

TI's published terms of sale for semiconductor products (<http://www.ti.com/sc/docs/stdterms.htm>) apply to the sale of packaged integrated circuit products that TI has qualified and released to market. Additional terms may apply to the use or sale of other types of TI products and services.

Reproduction of significant portions of TI information in TI data sheets is permissible only if reproduction is without alteration and is accompanied by all associated warranties, conditions, limitations, and notices. TI is not responsible or liable for such reproduced documentation. Information of third parties may be subject to additional restrictions. Resale of TI products or services with statements different from or beyond the parameters stated by TI for that product or service voids all express and any implied warranties for the associated TI product or service and is an unfair and deceptive business practice. TI is not responsible or liable for any such statements.

Buyers and others who are developing systems that incorporate TI products (collectively, "Designers") understand and agree that Designers remain responsible for using their independent analysis, evaluation and judgment in designing their applications and that Designers have full and exclusive responsibility to assure the safety of Designers' applications and compliance of their applications (and of all TI products used in or for Designers' applications) with all applicable regulations, laws and other applicable requirements. Designer represents that, with respect to their applications, Designer has all the necessary expertise to create and implement safeguards that (1) anticipate dangerous consequences of failures, (2) monitor failures and their consequences, and (3) lessen the likelihood of failures that might cause harm and take appropriate actions. Designer agrees that prior to using or distributing any applications that include TI products, Designer will thoroughly test such applications and the functionality of such TI products as used in such applications.

TI's provision of technical, application or other design advice, quality characterization, reliability data or other services or information, including, but not limited to, reference designs and materials relating to evaluation modules, (collectively, "TI Resources") are intended to assist designers who are developing applications that incorporate TI products; by downloading, accessing or using TI Resources in any way, Designer (individually or, if Designer is acting on behalf of a company, Designer's company) agrees to use any particular TI Resource solely for this purpose and subject to the terms of this Notice.

TI's provision of TI Resources does not expand or otherwise alter TI's applicable published warranties or warranty disclaimers for TI products, and no additional obligations or liabilities arise from TI providing such TI Resources. TI reserves the right to make corrections, enhancements, improvements and other changes to its TI Resources. TI has not conducted any testing other than that specifically described in the published documentation for a particular TI Resource.

Designer is authorized to use, copy and modify any individual TI Resource only in connection with the development of applications that include the TI product(s) identified in such TI Resource. NO OTHER LICENSE, EXPRESS OR IMPLIED, BY ESTOPPEL OR OTHERWISE TO ANY OTHER TI INTELLECTUAL PROPERTY RIGHT, AND NO LICENSE TO ANY TECHNOLOGY OR INTELLECTUAL PROPERTY RIGHT OF TI OR ANY THIRD PARTY IS GRANTED HEREIN, including but not limited to any patent right, copyright, mask work right, or other intellectual property right relating to any combination, machine, or process in which TI products or services are used. Information regarding or referencing third-party products or services does not constitute a license to use such products or services, or a warranty or endorsement thereof. Use of TI Resources may require a license from a third party under the patents or other intellectual property of the third party, or a license from TI under the patents or other intellectual property of TI.

TI RESOURCES ARE PROVIDED "AS IS" AND WITH ALL FAULTS. TI DISCLAIMS ALL OTHER WARRANTIES OR REPRESENTATIONS, EXPRESS OR IMPLIED, REGARDING RESOURCES OR USE THEREOF, INCLUDING BUT NOT LIMITED TO ACCURACY OR COMPLETENESS, TITLE, ANY EPIDEMIC FAILURE WARRANTY AND ANY IMPLIED WARRANTIES OF MERCHANTABILITY, FITNESS FOR A PARTICULAR PURPOSE, AND NON-INFRINGEMENT OF ANY THIRD PARTY INTELLECTUAL PROPERTY RIGHTS. TI SHALL NOT BE LIABLE FOR AND SHALL NOT DEFEND OR INDEMNIFY DESIGNER AGAINST ANY CLAIM, INCLUDING BUT NOT LIMITED TO ANY INFRINGEMENT CLAIM THAT RELATES TO OR IS BASED ON ANY COMBINATION OF PRODUCTS EVEN IF DESCRIBED IN TI RESOURCES OR OTHERWISE. IN NO EVENT SHALL TI BE LIABLE FOR ANY ACTUAL, DIRECT, SPECIAL, COLLATERAL, INDIRECT, PUNITIVE, INCIDENTAL, CONSEQUENTIAL OR EXEMPLARY DAMAGES IN CONNECTION WITH OR ARISING OUT OF TI RESOURCES OR USE THEREOF, AND REGARDLESS OF WHETHER TI HAS BEEN ADVISED OF THE POSSIBILITY OF SUCH DAMAGES.

Unless TI has explicitly designated an individual product as meeting the requirements of a particular industry standard (e.g., ISO/TS 16949 and ISO 26262), TI is not responsible for any failure to meet such industry standard requirements.

Where TI specifically promotes products as facilitating functional safety or as compliant with industry functional safety standards, such products are intended to help enable customers to design and create their own applications that meet applicable functional safety standards and requirements. Using products in an application does not by itself establish any safety features in the application. Designers must ensure compliance with safety-related requirements and standards applicable to their applications. Designer may not use any TI products in life-critical medical equipment unless authorized officers of the parties have executed a special contract specifically governing such use. Life-critical medical equipment is medical equipment where failure of such equipment would cause serious bodily injury or death (e.g., life support, pacemakers, defibrillators, heart pumps, neurostimulators, and implantables). Such equipment includes, without limitation, all medical devices identified by the U.S. Food and Drug Administration as Class III devices and equivalent classifications outside the U.S.

TI may expressly designate certain products as completing a particular qualification (e.g., Q100, Military Grade, or Enhanced Product). Designers agree that it has the necessary expertise to select the product with the appropriate qualification designation for their applications and that proper product selection is at Designers' own risk. Designers are solely responsible for compliance with all legal and regulatory requirements in connection with such selection.

Designer will fully indemnify TI and its representatives against any damages, costs, losses, and/or liabilities arising out of Designer's non-compliance with the terms and provisions of this Notice.

Looking for pricing, stock, or lifecycle information?

Click below to explore more details on WIN SOURCE:

 [View DRV8850RGYT](#) on WIN SOURCE

 [Texas Instruments](#) Information

Optimize Your Supply Chain with WIN SOURCE Solutions

-  Global Sourcing Solution
-  Obsolete Management
-  Cost Control Management
-  Shortage Management
-  Alternative Solution
-  Excess Inventory Management