



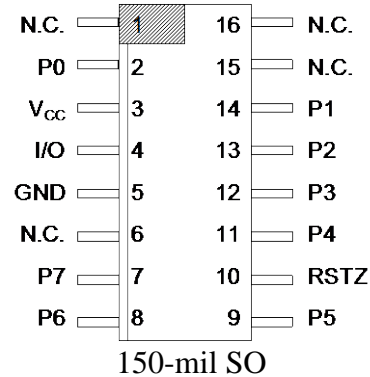
**THE DATASHEET OF  
DS2408S+T&R**



### BENEFITS AND FEATURES

- Control Eight Independent I/O Port Pins from a Single Micro Port Pin
  - Eight Channels of Programmable I/O with Open-Drain Outputs
  - On-Resistance of PIO Pulldown Transistor 100Ω (max); Off-Resistance 10MΩ (typ)
  - Individual Activity Latches Capture Asynchronous State Changes at PIO Inputs for Interrogation by the Bus Master
  - Data-Strobe Output to Synchronize PIO Logic States to External Read/Write Circuitry
  
- Minimalist 1-Wire Interface Lowers Cost and Interface Complexity
  - Built-in Multidrop Controller Ensures Compatibility with Other 1-Wire® Net Products
  - Supports 1-Wire Conditional Search Command with Response Controlled by Programmable PIO Conditions
  - Unique Factory-Lasered 64-Bit Registration Number Ensures Error-Free Device Selection and Absolute Part Identity
  - Communicates to Host with a Single Digital Signal at 15.3kbps or 100kbps
  
- Wide Voltage and Temperature Operating Ranges Enables Robust System Performance
  - 2.8V to 5.25V
  - -40°C to +85°C Industrial Temperature Range

### PIN CONFIGURATION



### ORDERING INFORMATION

PART	TEMP RANGE	PIN-PACKAGE
DS2408S+	-40°C to +85°C	16 SO
DS2408S+T&R	-40°C to +85°C	16 SO

+Denotes a lead(Pb)-free package.  
T&R = Tape and reel.

### DESCRIPTION

The DS2408 is an 8-channel, programmable I/O 1-Wire chip. PIO outputs are configured as open-drain and provide an on resistance of 100Ω max. A robust PIO channel-access communication protocol ensures that PIO output-setting changes occur error-free. A data-valid strobe output can be used to latch PIO logic states into external circuitry such as a D/A converter (DAC) or microcontroller data bus.

DS2408 operation is controlled over the single-conductor 1-Wire bus. Device communication follows the standard Dallas Semiconductor 1-Wire protocol. Each DS2408 has its own unalterable and unique 64-bit ROM registration number that is factory lasered into the chip. The registration number guarantees unique identification and is used to address the device in a multidrop 1-Wire net environment. Multiple DS2408 devices can reside on a common 1-Wire bus and can operate independently of each other. The DS2408 also supports 1-Wire conditional search capability based on PIO conditions or power-on-reset activity; the conditions to cause participation in the conditional search are programmable. The DS2408 has an optional V<sub>CC</sub> supply connection. When an external supply is absent, device power is supplied parasitically from the 1-Wire bus. When an external supply is present, PIO states are maintained in the absence of the 1-Wire bus power source. The RSTZ signal is configurable to serve as either a hard-wired reset for the PIO output or as a strobe for external circuitry to indicate that a PIO write or PIO read has completed.

*1-Wire is a registered trademark of Maxim Integrated Products, Inc.*

**ABSOLUTE MAXIMUM RATINGS\***

P0 to P7, RSTZ, I/O Voltage to GND	-0.5V, +6V
P0 to P7, RSTZ, I/O combined sink current	20mA
Operating Temperature Range	-40°C to +85°C
Junction Temperature	+150°C
Storage Temperature Range	-55°C to +125°C
Lead temperature (soldering 10s)	+300°C
Soldering Temperature (reflow)	+260°C

\* This is a stress rating only and functional operation of the device at these or any other conditions above those indicated in the operation sections of this specification is not implied. Exposure to absolute maximum rating conditions for extended periods of time may affect reliability.

**ELECTRICAL CHARACTERISTICS**

( $V_{CC} = 0V$  or  $\geq V_{PUP}$ ,  $T_A = -40^\circ C$  or  $+85^\circ C$ .)

PARAMETER	SYMBOL	CONDITIONS	MIN	TYP	MAX	UNITS
1-Wire Pullup Voltage	$V_{PUP}$	Standard speed	2.8		5.25	V
		Overdrive speed	3.3		5.25	
Standby Supply Current	$I_{CCS}$	$V_{CC}$ at $V_{PUP}$ , I/O pin at 0.3V			1	$\mu A$
<b>I/O Pin General Data</b>						
1-Wire Pullup Resistance	$R_{PUP}$	(Notes 1, 2)			2.2	k $\Omega$
Input Capacitance	$C_{IO}$	(Notes 3, 4)			1200	pF
Input Load Current	$I_L$	I/O pin at $V_{PUP}$ , $V_{CC}$ at 0V			1	$\mu A$
High-to-Low Switching Threshold	$V_{TL}$	(Notes 4, 5, 6)	0.5		3.2	V
Input-Low Voltage	$V_{IL}$	(Notes 1, 7)			0.30	V
Low-to-High Switching Threshold	$V_{TH}$	(Notes 4, 5, 8)	0.8		3.4	V
Switching Hysteresis	$V_{HY}$	(Notes 9, 4)	0.16		0.73	V
Output-Low Voltage at 4mA	$V_{OL}$	(Note 10)			0.4	V
Recovery Time (Note 1)	$t_{REC}$	Standard speed, $R_{PUP} = 2.2k\Omega$	5			$\mu s$
		Overdrive speed, $R_{PUP} = 2.2k\Omega$	2			
		Overdrive speed, Directly prior to reset pulse; $R_{PUP} = 2.2k\Omega$	5			
Rising-Edge Hold-off Time (Notes 11, 4)	$t_{REH}$	Standard speed	0.5		5	$\mu s$
		Overdrive speed	0.5		2	
Timeslot Duration (Notes 1, 12)	$t_{SLOT}$	Standard speed	65			$\mu s$
		Overdrive speed	10			

PARAMETER	SYMBOL	CONDITIONS	MIN	TYP	MAX	UNITS
<b>I/O Pin, 1-Wire Reset, Presence-Detect Cycle</b>						
Reset-Low Time (Notes 1, 12)	$t_{RSTL}$	Standard speed, $V_{PUP} > 4.5V$	480		720	$\mu s$
		Standard speed	660		720	
		Overdrive speed	53		80	
Presence-Detect High Time (Note 12)	$t_{PDH}$	Standard speed	15		60	$\mu s$
		Overdrive speed	2		7	
Presence-Detect Fall Time (Note 13)	$t_{FPD}$	Standard speed, $V_{PUP} > 4.5V$	1		5	$\mu s$
		Standard speed	1		8	
		Overdrive speed			1	
Presence-Detect Low Time (Note 12)	$t_{PDL}$	Standard speed, $V_{PUP} > 4.5V$	60		240	$\mu s$
		Standard speed	60		280	
		Overdrive speed	7		27	
Presence-Detect Sample Time (Note 1)	$t_{MSP}$	Standard speed, $V_{PUP} > 4.5V$	65		75	$\mu s$
		Standard speed	68		75	
		Overdrive speed	8		9	
<b>I/O Pin, 1-Wire Write</b>						
Write-0 Low Time (Notes 1, 12, 14)	$t_{W0L}$	Standard speed	60		120	$\mu s$
		Overdrive speed	8		13	
Write-1 Low Time (Notes 1, 12, 14)	$t_{W1L}$	Standard speed	5		15	$\mu s$
		Overdrive speed	1		1.8	
Write Sample Time (Slave Sampling) (Note 12)	$t_{SLS}$	Standard speed	15		60	$\mu s$
		Overdrive speed	1.8		8	
<b>I/O Pin, 1-Wire Read</b>						
Read-Low Time (Notes 1, 15)	$t_{RL}$	Standard speed	5		$15 - \delta$	$\mu s$
		Overdrive speed	1		$1.8 - \delta$	
Read-0 Low Time (Data From Slave) (Note 12)	$t_{SPD}$	Standard speed	15		60	$\mu s$
		Overdrive speed	1.8		8	
Read-Sample Time (Notes 1, 12, 15)	$t_{MSR}$	Standard speed	$t_{RL} + \delta$		15	$\mu s$
		Overdrive speed	$t_{RL} + \delta$		1.8	
<b>P0 to P7, RSTZ Pin</b>						
Input-Low Voltage	$V_{IL}$	(Notes 1, 7)			0.30	V
Input-High Voltage	$V_{IH}$	$V_X = \max(V_{PUP}, V_{CC})$ (Note 1)	$V_X - 0.8$		5.25	V
Output-Low Voltage at 4mA	$V_{OL}$	(Note 10)			0.4	V
Leakage Current	$I_{LP}$	5.25V at the pin			1	$\mu A$
Output Fall Time	$t_{FPIO}$	(Notes 4, 16)	100			ns
Minimum-Sensed PIO Pulse	$t_{PWMIN}$	(Notes 4, 17)	1		5	$\mu s$

- Note 1:** System Requirement
- Note 2:** Maximum allowable pullup resistance is a function of the number of 1-Wire devices in the system and 1-Wire recovery times. The specified value here applies to systems with only one device and with the minimum 1-Wire recovery times. For more heavily loaded systems, an active pullup such as that found in the DS2480B may be required.
- Note 3:** If a 2.2k $\Omega$  resistor is used to pull up the data line to  $V_{PUP}$ , 5 $\mu$ s after power has been applied, the parasite capacitance does not affect normal communications.
- Note 4:** Guaranteed by design—not production tested.
- Note 5:**  $V_{TL}$  and  $V_{TH}$  are functions of the internal supply voltage, which in parasitic power mode, is a function of  $V_{PUP}$  and the 1-Wire recovery times. The  $V_{TH}$  and  $V_{TL}$  maximum specifications are valid at  $V_{PUP} = 5.25V$ . In any case,  $V_{TL} < V_{TH} < V_{PUP}$ .
- Note 6:** Voltage below which, during a falling edge on I/O, a logic '0' is detected.
- Note 7:** The voltage on I/O needs to be less or equal to  $V_{ILMAX}$  whenever the master drives the line low.
- Note 8:** Voltage above which, during a rising edge on I/O, a logic '1' is detected.
- Note 9:** After  $V_{TH}$  is crossed during a rising edge on I/O, the voltage on I/O has to drop by  $V_{HY}$  to be detected as logic '0'.
- Note 10:** The I-V characteristic is linear for voltages less than 1V.
- Note 11:** The earliest recognition of a negative edge is possible at  $t_{REH}$  after  $V_{TH}$  has been reached before.
- Note 12:** Highlighted numbers are NOT in compliance with the published 1-Wire standards. See comparison table below.
- Note 13:** Interval during the negative edge on I/O at the beginning of a presence detect pulse between the time at which the voltage is 90% of  $V_{PUP}$  and the time at which the voltage is 10% of  $V_{PUP}$ .
- Note 14:**  $\epsilon$  in Figure 14 represents the time required for the pullup circuitry to pull the voltage on I/O up from  $V_{IL}$  to  $V_{TH}$ . The actual maximum duration for the master to pull the line low is  $t_{WILMAX} + t_F - \epsilon$  and  $t_{WOLMAX} + t_F - \epsilon$  respectively.
- Note 15:**  $\delta$  in Figure 14 represents the time required for the pullup circuitry to pull the voltage on I/O up from  $V_{IL}$  to the input high threshold of the bus master. The actual maximum duration for the master to pull the line low is  $t_{RLMAX} + t_F$ .
- Note 16:** Interval during the device-generated negative edge on any PIO pin or the RSTZ pin between the time at which the voltage is 90% of  $V_{PUP}$  and the time at which the voltage is 10% of  $V_{PUP}$ . PIO pullup resistor = 2.2k $\Omega$ .
- Note 17:** Width of the narrowest pulse which trips the activity latch (for any PIO pin) or causes a reset (for the RSTZ pin). For a pulse duration  $t_{PW}$ : If  $t_{PW} < t_{PWMIN(min)}$ , the pulse will be rejected. If  $t_{PWMIN(min)} < t_{PW} < t_{PWMIN(max)}$ , the pulse may or may not be rejected. If  $t_{PW} > t_{PWMIN(max)}$  the pulse will be recognized and latched.
- Note 18:** Maximum instantaneous pulldown current through all port pins and the RSTZ pin combined. No requirement for current balance among different pins.

PARAMETER NAME	STANDARD VALUES				DS2408 VALUES			
	STANDARD SPEED		OVERDRIVE SPEED		STANDARD SPEED		OVERDRIVE SPEED	
	MIN	MAX	MIN	MAX	MIN	MAX	MIN	MAX
$t_{SLOT}$ (incl. $t_{REC}$ )	61 $\mu$ s	(undef.)	7 $\mu$ s	(undef.)	65 $\mu$ s <sup>1)</sup>	(undef.)	10 $\mu$ s	(undef.)
$t_{RSTL}$	480 $\mu$ s	(undef.)	48 $\mu$ s	80 $\mu$ s	660 $\mu$ s	720 $\mu$ s	53 $\mu$ s	80 $\mu$ s
$t_{PDH}$	15 $\mu$ s	60 $\mu$ s	2 $\mu$ s	6 $\mu$ s	15 $\mu$ s	60 $\mu$ s	2 $\mu$ s	7 $\mu$ s
$t_{PDL}$	60 $\mu$ s	240 $\mu$ s	8 $\mu$ s	24 $\mu$ s	60 $\mu$ s	280 $\mu$ s	7 $\mu$ s	27 $\mu$ s
$t_{WOL}$	60 $\mu$ s	120 $\mu$ s	6 $\mu$ s	16 $\mu$ s	60 $\mu$ s	120 $\mu$ s	8 $\mu$ s	13 $\mu$ s
$t_{SLS}$ , $t_{SPD}$	15 $\mu$ s	60 $\mu$ s	2 $\mu$ s	6 $\mu$ s	15 $\mu$ s	60 $\mu$ s	1.8 $\mu$ s	8 $\mu$ s

<sup>1)</sup> Intentional change, longer recovery-time requirement due to modified 1-Wire front end.

## PIN DESCRIPTION

PIN	NAME	DESCRIPTION
1	N.C.	Not Connected
2	P0	I/O Pin of Channel 0. Logic input/open-drain output with 100 $\Omega$ maximum on-resistance; 0V to 5.25V operating range. Power-on default is indeterminate. If it is application-critical for the outputs to power up in the "off" state, the user should attach an appropriate power-on-reset circuit or supervisor IC to the RSTZ pin.
3	V <sub>CC</sub>	Optional Power Supply Input. Range 2.8V to 5.25V; must be tied to GND if not used.
4	I/O	1-Wire Interface. Open-drain, requires external pullup resistor.
5	GND	Ground
6	N.C.	Not Connected
7	P7	I/O Pin of Channel 7. Same characteristics as P0.
8	P6	I/O Pin of Channel 6. Same characteristics as P0.
9	P5	I/O Pin of Channel 5. Same characteristics as P0.
10	RSTZ	SW configurable PIO reset input ( $\overline{RST}$ ) or open-drain strobe output ( $\overline{STRB}$ ). When configured as $\overline{RST}$ , a LOW input sets all PIO outputs to the "off" state by setting all bits in the PIO Output Latch State Register. When configured as $\overline{STRB}$ , an output strobe will occur after a PIO write (see Channel-Access Write command) or after a PIO Read (see Channel-Access Read command). The power-on default function of this pin is $\overline{RST}$ .
11	P4	I/O pin of channel 4; same characteristics as P0
12	P3	I/O pin of channel 3; same characteristics as P0
13	P2	I/O pin of channel 2; same characteristics as P0
14	P1	I/O pin of channel 1; same characteristics as P0
15	N.C.	Not connected
16	N.C.	Not connected

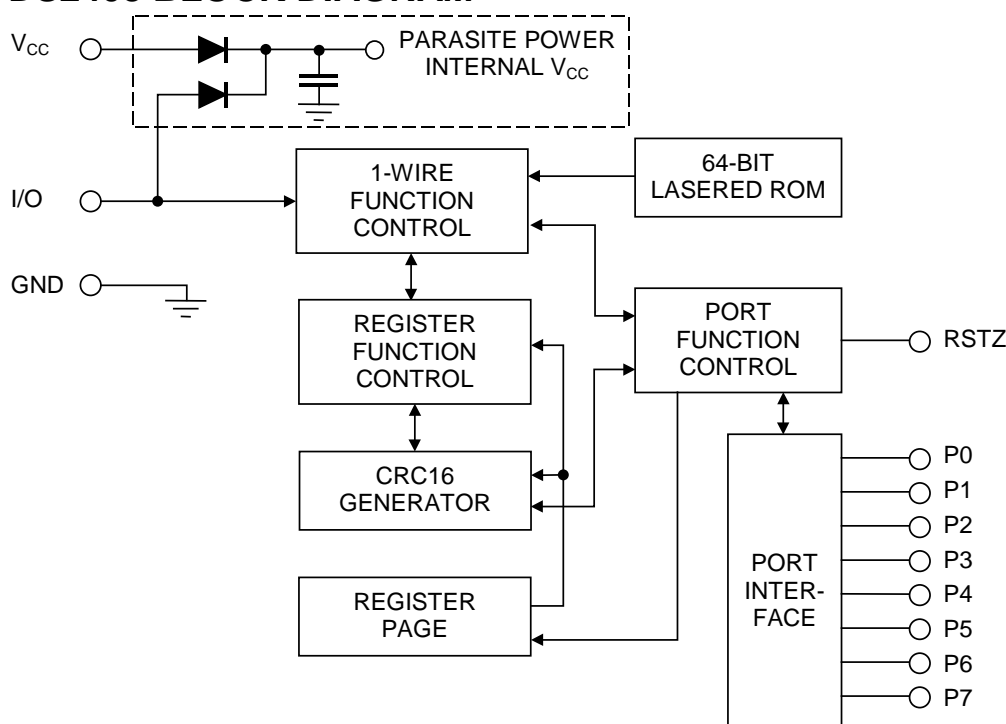
## APPLICATION

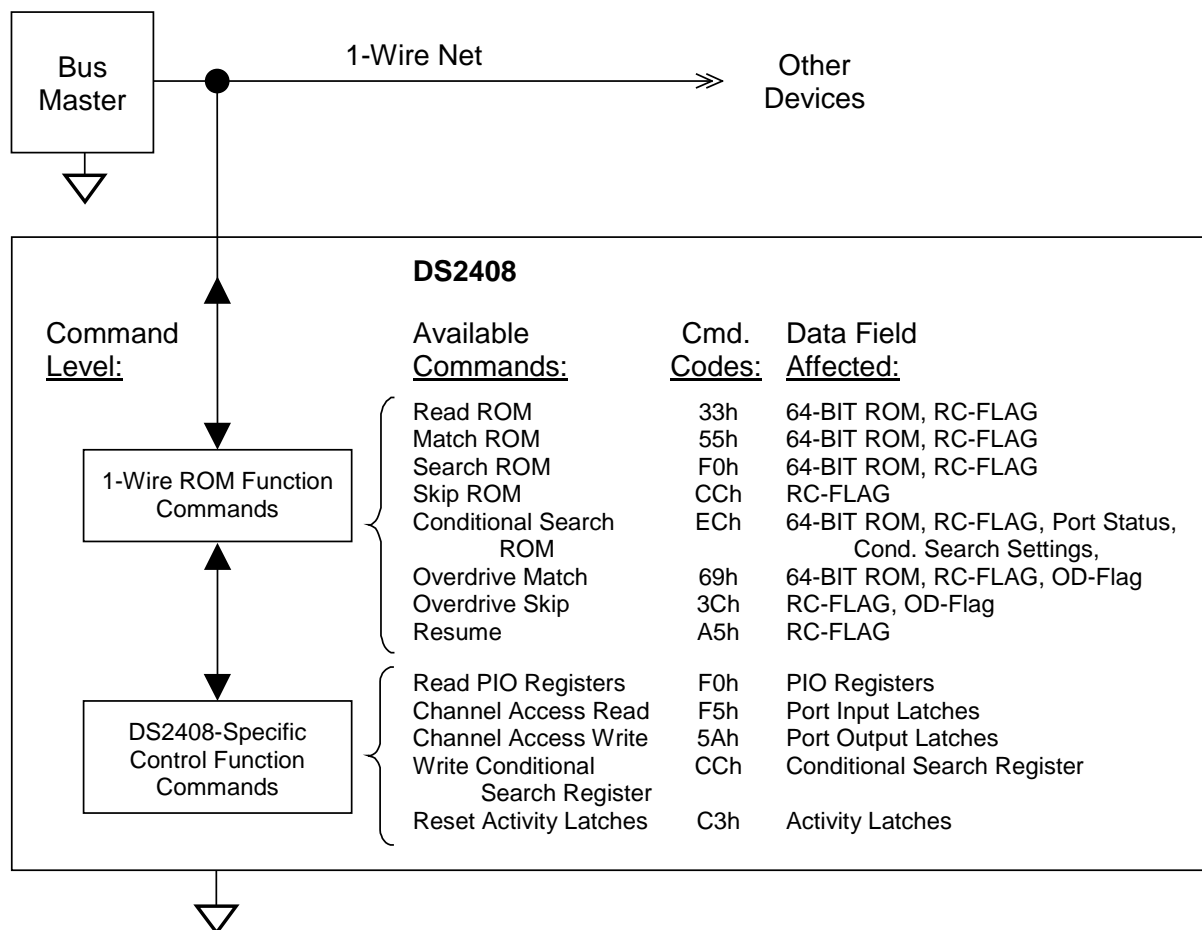
The DS2408 is a multipurpose device. Typical applications include port expander for microcontrollers, remote multichannel sensor/actuator, communication and control unit of a microterminal, or as network interface of a microcontroller. Typical application circuits and communication examples are found later in this data sheet (Figures 17 to 22).

## OVERVIEW

Figure 1 shows the relationships between the major function blocks of the DS2408. The device has two main data components: 1) 64-bit lasered ROM, and 2) 64-bit register page of control and status registers. Figure 2 shows the hierarchical structure of the 1-Wire protocol. The bus master must first provide one of the eight ROM function commands: 1) Read ROM, 2) Match ROM, 3) Search ROM, 4) Conditional Search ROM, 5) Skip ROM, 6) Overdrive-Skip ROM, 7) Overdrive-Match ROM, or 8) Resume. Upon completion of an Overdrive ROM command byte executed at standard speed, the device will enter overdrive mode, where all subsequent communication occurs at a higher speed. The protocol required for these ROM function commands is described in Figure 12. After a ROM function command is successfully executed, the control functions become accessible and the master may provide any one of the five available commands. The protocol for these control commands is described in Figure 8. All data is read and written least significant bit first.

**Figure 1. DS2408 BLOCK DIAGRAM**

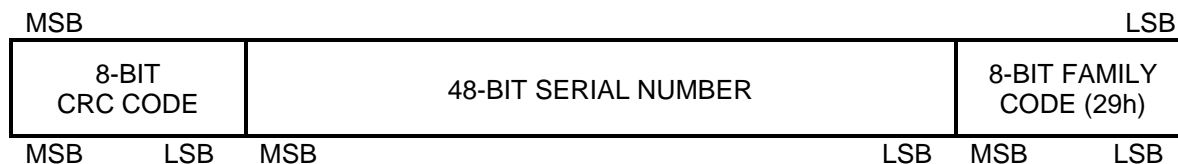


**Figure 2. HIERARCHICAL STRUCTURE FOR 1-Wire PROTOCOL**

## PARASITE POWER

The DS2408 can derive its power entirely from the 1-Wire bus by storing energy on an internal capacitor during periods of time when the signal line is high. During low times the device continues to operate from this “parasite” power source until the 1-Wire bus returns high to replenish the parasite (capacitor) supply. If power is available, the  $V_{CC}$  pin should be connected to the external voltage supply.

## Figure 3. 64-BIT LASERED ROM

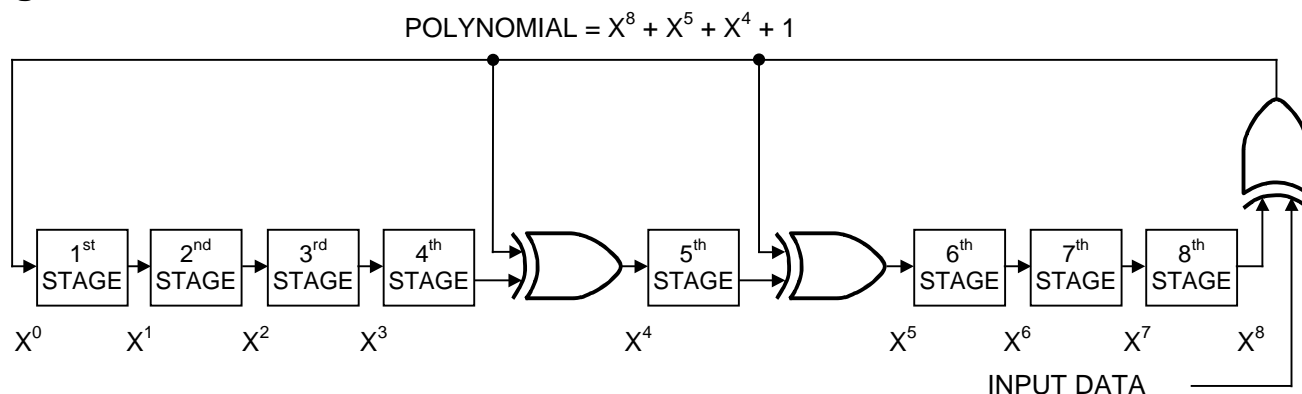


## 64-BIT LASERED ROM

Each DS2408 contains a unique ROM code that is 64 bits long. The first 8 bits are a 1-Wire family code. The next 48 bits are a unique serial number. The last eight bits are a CRC of the first 56 bits. See Figure 3 for details. The 1-Wire CRC is generated using a polynomial generator consisting of a shift register and XOR gates as shown in Figure 4. The polynomial is  $X^8 + X^5 + X^4 + 1$ . Additional information about the Dallas 1-Wire Cyclic Redundancy Check is available in *Application Note 27*.

The shift register bits are initialized to 0. Then, starting with the least significant bit of the family code, one bit at a time is shifted in. After the eighth bit of the family code has been entered, the serial number is entered. After the serial number has been entered, the shift register contains the CRC value. Shifting in the eight bits of CRC returns the shift register to all 0s.

**Figure 4. 1-Wire CRC GENERATOR**



## REGISTER ACCESS

The registers needed to operate the DS2408 are organized as a Register Page, as shown in Figure 5. All registers are volatile, i. e., they lose their state when the device is powered down. PIO, Conditional Search, and Control/Status registers are read/written using the device level *Read PIO Registers* and *Write Conditional Search Register* commands described in subsequent sections and Figure 8 of this document.

**Figure 5. DS2408 REGISTER ADDRESS MAP**

ADDRESS RANGE	ACCESS TYPE	DESCRIPTION
0000h to 0087h	R	Undefined Data
0088h	R	PIO Logic State
0089h	R	PIO Output Latch State Register
008Ah	R	PIO Activity Latch State Register
008Bh	R/W	Conditional Search Channel Selection Mask
008Ch	R/W	Conditional Search Channel Polarity Selection
008Dh	R/W	Control/Status Register
008Eh to 008Fh	R	These Bytes Always Read FFh

## PIO Logic-State Register

The logic state of the PIO pins can be obtained by reading this register using the Read PIO Registers command. Reading this register does not generate a signal at the RSTZ pin, even if it is configured as  $\overline{\text{STRB}}$ . See the *Channel-Access* commands description for details on  $\overline{\text{STRB}}$ .

### PIO Logic State Register Bitmap

ADDR	b7	b6	b5	b4	b3	b2	b1	b0
0088h	P7	P6	P5	P4	P3	P2	P1	P0

This register is read-only. Each bit is associated with the pin of the respective PIO channel as shown in Figure 6. The data in this register is sampled at the last (most significant) bit of the byte that proceeds reading the first (least significant) bit of this register. See the *Read PIO Registers* command description for details.

## PIO Output Latch State Register

The data in this register represents the latest data written to the PIO through the Channel-access Write command. This register is read using the Read PIO Registers command. Reading this register does not generate a signal at the RSTZ pin, even if it is configured as  $\overline{\text{STRB}}$ . See the *Channel-access* commands description for details on  $\overline{\text{STRB}}$ . This register is not affected if the device reinitializes itself after an ESD hit.

### PIO Output Latch State Register Bitmap

ADDR	b7	b6	b5	b4	b3	b2	b1	b0
0089h	PL7	PL6	PL5	PL4	PL3	PL2	PL1	PL0

This register is read-only. Each bit is associated with the output latch of the respective PIO channel as shown in Figure 6.

The flip-flops of this register will power up in a random state. If the chip has to power up with all PIO channels off, a LOW pulse must be generated on the RSTZ pin, e.g., by means of an open-drain CPU supervisor chip (see Figure 20). When using an RC circuit to generate the power-on reset, make sure that RSTZ is NOT configured as strobe output (ROS bit in control/status register 008Dh needs to be 0).

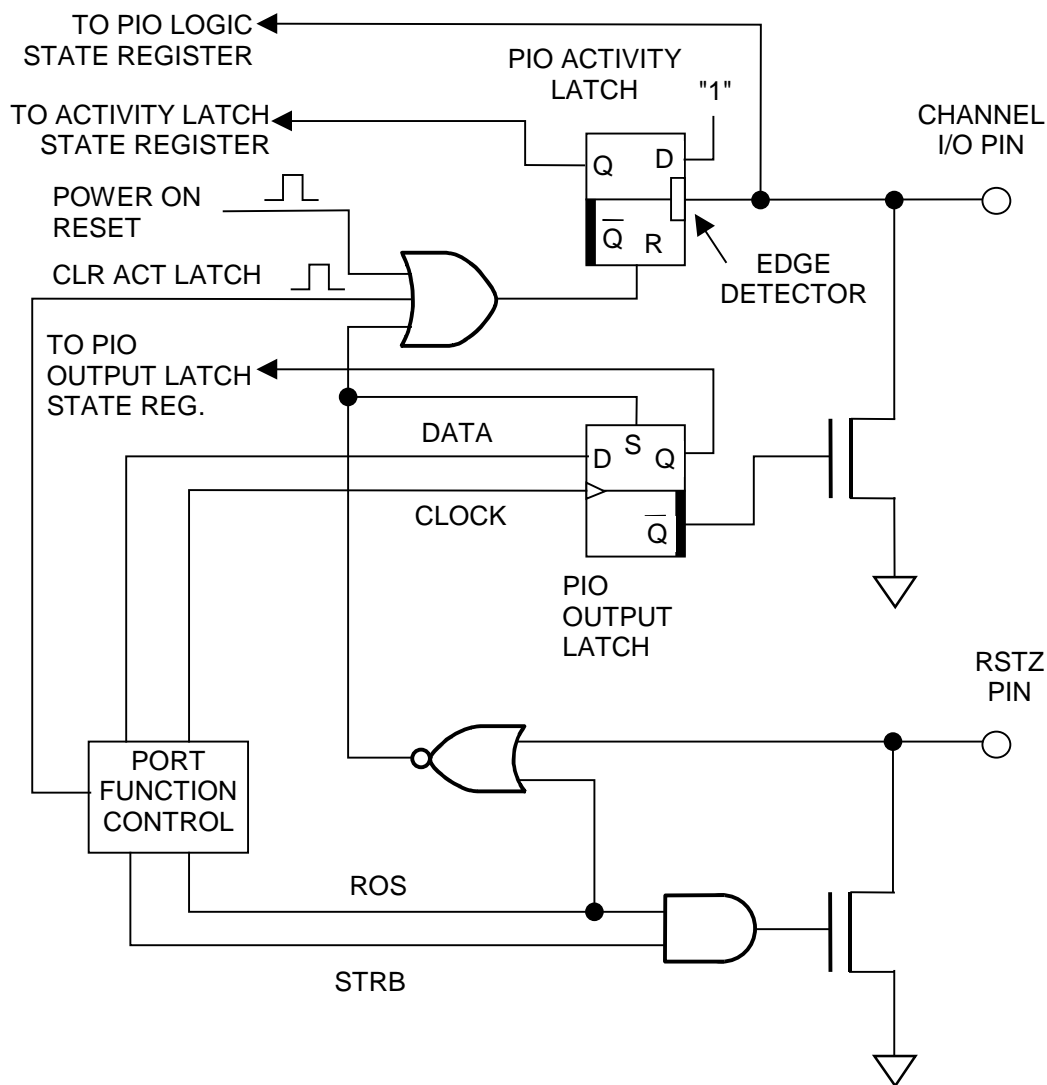
## PIO Activity Latch State Register

The data in this register represents the current state of the PIO activity latches. This register is read using the Read PIO Registers command. Reading this register does not generate a signal at the RSTZ pin, even if it is configured as  $\overline{\text{STRB}}$ . See the *Channel-access* commands description for details on  $\overline{\text{STRB}}$ .

### PIO Activity Latch State Register Bitmap

ADDR	b7	b6	b5	b4	b3	b2	b1	b0
008Ah	AL7	AL6	AL5	AL4	AL3	AL2	AL1	AL0

This register is read-only. Each bit is associated with the activity latch of the respective PIO channel as shown in Figure 6. This register is cleared to 00h by a power-on reset, by a low pulse on the RSTZ pin (only if RSTZ is configured as  $\overline{\text{RST}}$  input), or by successful execution of the Reset Activity Latches command.

**Figure 6. CHANNEL I/O AND RSTZ SIMPLIFIED LOGIC DIAGRAM**

### Conditional Search Channel Selection Mask Register

The data in this register controls whether a PIO channel qualifies for participation in the conditional search command. To include one or more of the PIO channels, the bits in this register that correspond to those channels need to be set to 1. This register can only be written through the Write Conditional Search Registers command.

### Conditional Search Channel Selection Mask Register Bitmap

ADDR	b7	b6	b5	b4	b3	b2	b1	b0
008Bh	SM7	SM6	SM5	SM4	SM3	SM2	SM1	SM0

This register is read/write. Each bit is associated with the respective PIO channel as shown in Figure 7. This register is cleared to 00h by a power-on reset

## Conditional Search Channel Polarity Selection Register

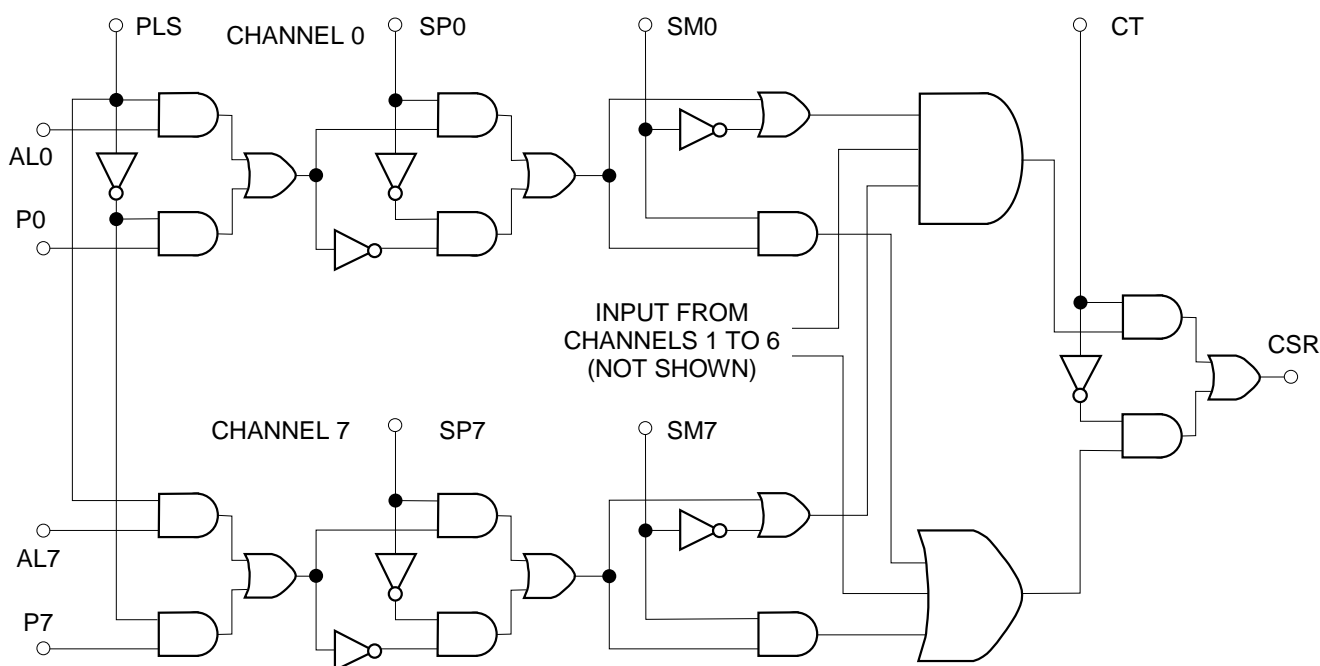
The data in this register specifies the polarity of each selected PIO channel for the device to respond to the conditional search command. Within a PIO channel, the data source may be either the channel's input signal (pin) or the channel's activity latch, as specified by the PLS bit in the Control/Status register at address 008Dh. This register can only be written through the Write Conditional Search Registers command.

## Conditional Search Channel Polarity Selection Register Bitmap

ADDR	b7	b6	b5	b4	b3	b2	b1	b0
008Ch	SP7	SP6	SP5	SP4	SP3	SP2	SP1	SP0

This register is read/write. Each bit is associated with the respective PIO channel as shown in Figure 7. This register is cleared to 00h by a power-on reset.

**Figure 7. Conditional Search Logic**



## Control/Status Register

The data in this register reports status information, determines the function of the RSTZ pin and further configures the device for conditional search. This register can only be written through the Write Conditional Search Registers command.

### Control/Status Register Bitmap

ADDR	b7	b6	b5	b4	b3	b2	b1	b0
008Dh	VCCP	0	0	0	PORL	ROS	CT	PLS

This register is read/write. Without  $V_{CC}$  supply, this register reads 08h after a power-on reset. The functional assignments of the individual bits are explained in the table below. Bits 4 to 6 have no function; they will always read 0 and cannot be set to 1.

### Control/Status Register Details

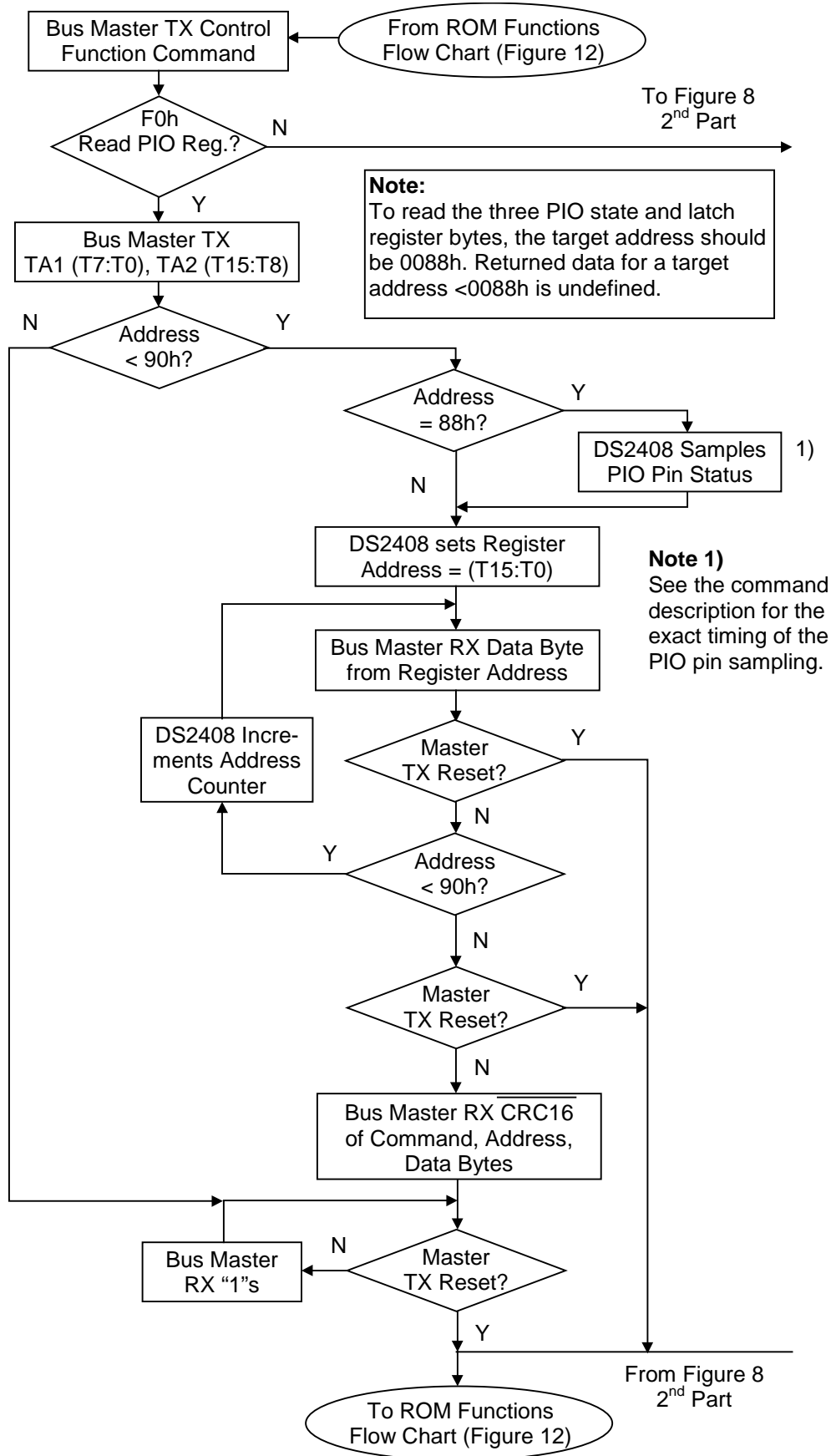
BIT DESCRIPTION	BIT(S)	DEFINITION
PLS: Pin or Activity Latch Select	b0	Selects either the PIO pins or the PIO activity latches as input for the conditional search. 0: pin selected (default) 1: activity latch selected
CT: Conditional Search Logical Term	b1	Specifies whether the data of two or more channels needs to be OR'ed or AND'ed to meet the qualifying condition for the device to respond to a conditional search. If only a single channel is selected in the channel selection mask (008Bh) this bit is a don't care. 0: bitwise OR (default) 1: bitwise AND
ROS: RSTZ Pin Mode Control	b2	Configures RSTZ as either $\overline{RST}$ input or $\overline{STRB}$ output 0: configured as $\overline{RST}$ input (default) 1: configured as $\overline{STRB}$ output
PORL: Power-On Reset Latch	b3	Specifies whether the device has performed a power-on reset. This bit can only be cleared to 0 under software control. As long as this bit is 1 the device will always respond to a conditional search.
VCCP: $V_{CC}$ Power Status (Read-Only)	b7	For $V_{CC}$ powered operation the $V_{CC}$ pin needs to be tied to a voltage source $\geq V_{PUP}$ . 0: $V_{CC}$ pin is grounded 1: $V_{CC}$ -powered operation

The interaction of the various signals that determine whether the device responds to a conditional search is illustrated in Figure 7. The selection mask SM selects the participating channels. The polarity selection SP determines for each channel whether the channel signal needs to be 1 or 0 to qualify. The PLS bit determines whether all channel signals are taken from the activity latches or I/O pins. The signals of all channels are fed into an AND gate as well as an OR gate. The CT bit finally selects the AND'ed or OR'ed result as the conditional search response signal CSR.

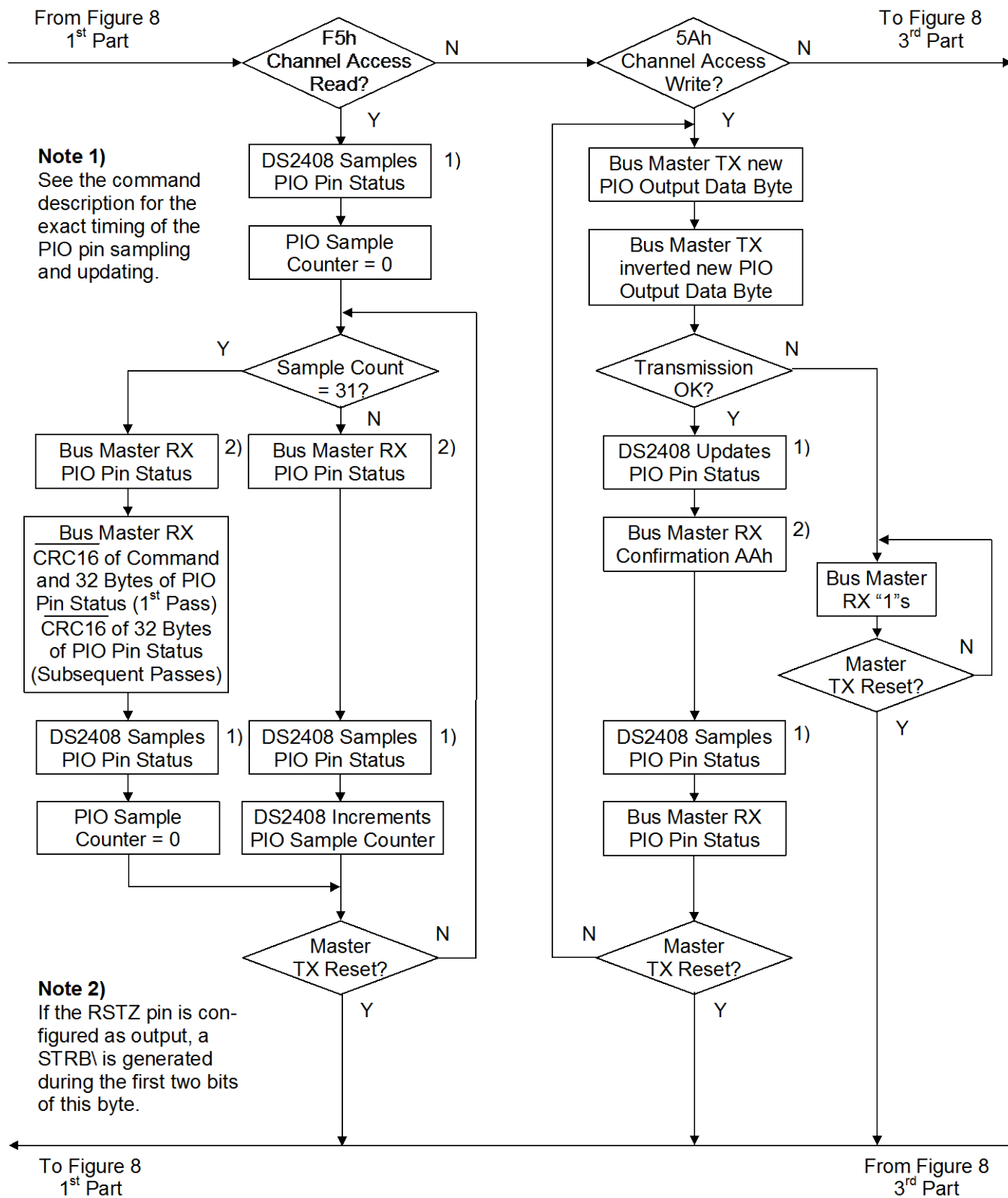
#### Note on CT bit:

- OR    The qualifying condition is met if the input (pin state or activity latch) for one or more selected channels matches the corresponding polarity.
- AND   For the qualifying condition to be met, the input (pin state or activity latch) for every selected channel must match the corresponding polarity.

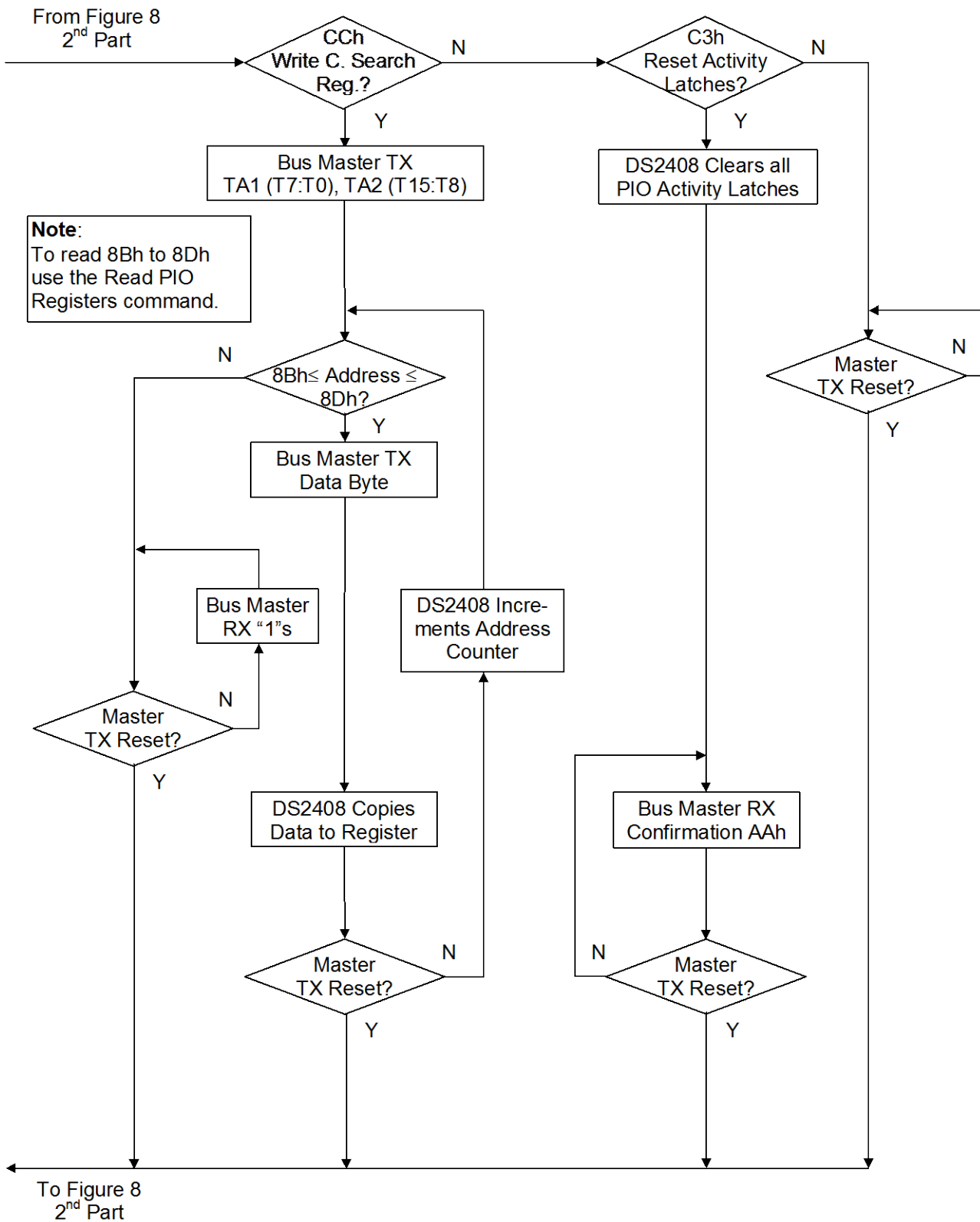
**Figure 8-1. CONTROL FUNCTIONS FLOW CHART**



**Figure 8-2. CONTROL FUNCTIONS FLOW CHART**



**Figure 8-3. CONTROL FUNCTIONS FLOW CHART**



## CONTROL FUNCTION COMMANDS

Once a ROM function command is completed, the Control Function Commands can be issued. The *Control Functions Flow Chart* (Figure 8) describes the protocols necessary for accessing the PIO channels and the special function registers of the DS2408. The communication between the master and the DS2408 takes place either at standard speed (default, OD = 0) or at overdrive speed (OD = 1). If not explicitly set into the overdrive mode, the device operates at standard speed.

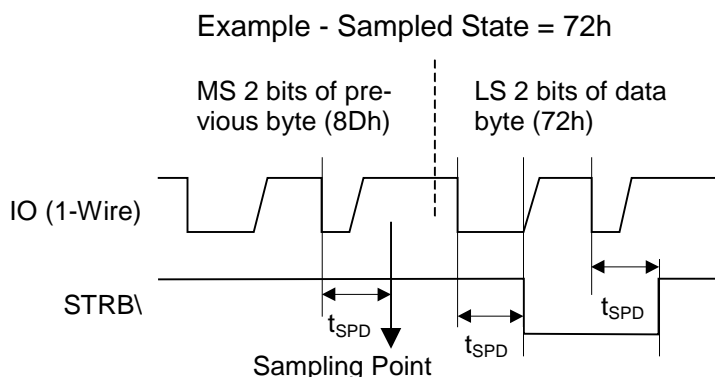
### Read PIO Registers [F0h]

The Read PIO Registers command is used to read any of the device's registers. After issuing the command, the master must provide the 2-byte target address. After these two bytes, the master reads data beginning from the target address and may continue until address 008Fh. If the master continues reading, it will receive an inverted 16-bit CRC of the command, address bytes, and all data bytes read from the initial starting byte through the end of the register page. This CRC16 is the result of clearing the CRC generator and then shifting in the command byte followed by the two address bytes and the data bytes beginning at the first addressed location and continuing through to the last byte of the register page. After the bus master has received the CRC16, the DS2408 responds to any subsequent read-time slots with logical 1's until a 1-Wire Reset command is issued. If this command is issued with target address 0088h (PIO Logic State Register), the PIO sampling takes place during the transmission of the MS bit of TA2. If the target address is lower than 0088h, the sampling takes place while the master reads the MS bit from address 0087h.

### Channel-Access Read [F5h]

In contrast to reading the PIO logical state from address 88h, this command reads the status in an endless loop. After 32 bytes of PIO pin status the DS2408 inserts an inverted CRC16 into the data stream, which allows the master to verify whether the data was received error-free. A Channel-Access Read can be terminated at any time with a 1-Wire Reset.

## Figure 9. CHANNEL-ACCESS READ TIMING



### Notes:

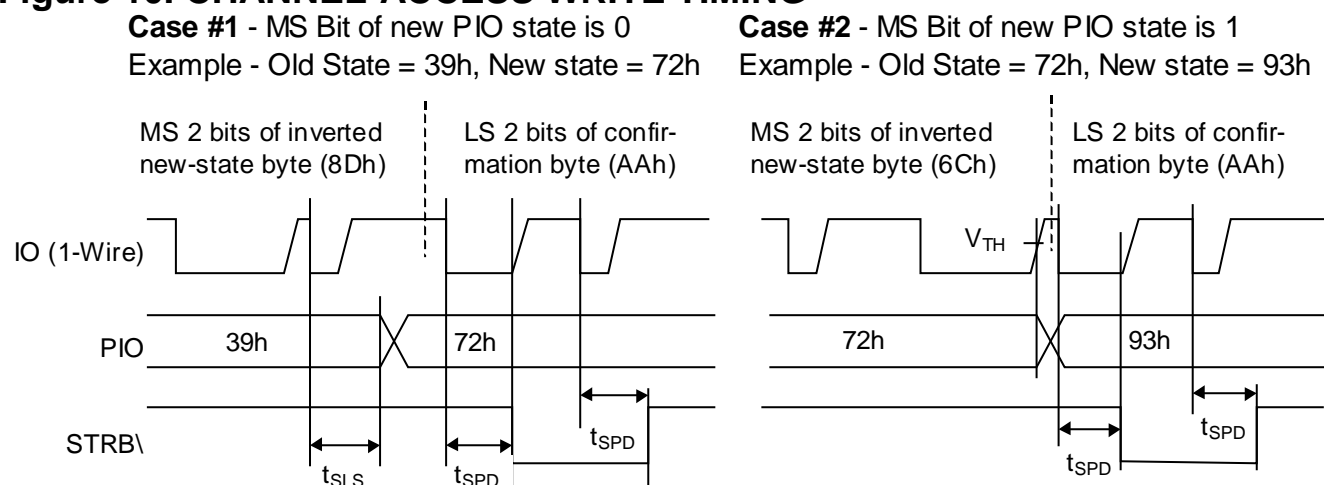
- 1) The "previous byte" could be the command code, the data byte resulting from the previous PIO sample, or the MS byte of a CRC16. The example shows a read-1 time slot.
- 2) The sample point timing also applies to the Channel-access Write command, with the "previous byte" being the write confirmation byte (AAh). No  $\overline{STRB}$  pulse results when sampling occurs during a Channel-Access Write command.

The status of all eight PIO channels is sampled at the same time. The first sampling occurs during the last (most significant) bit of the command code F5h. While the master receives the MSB of the PIO status (i.e., the status of pin P7) the next sampling occurs and so on until the master has received 31 PIO samples. Next, the master receives the inverted CRC16 of the command byte and 32 PIO samples (first pass) or the CRC of 32 PIO samples (subsequent passes). While the last (most significant) bit of the CRC is transmitted the next PIO sampling takes place. The delay between the beginning of the time slot and the sampling point is independent of the bit value being transmitted and the data direction (see Figure 9). If the RSTZ pin is configured as  $\overline{\text{STRB}}$ , a strobe signal will be generated during the transmission of the first two (least significant) bits of PIO data. The strobe can signal a FIFO or a microcontroller to apply the next data byte at the PIO for the master to read through the 1-Wire line.

## Channel-Access Write [5Ah]

The Channel-Access Write command is the only way to write to the PIO output-latch state register (address 0089h), which controls the open-drain output transistors of the PIO channels. In an endless loop this command first writes new data to the PIO and then reads back the PIO status. The implicit read-after-write can be used by the master for status verification or for a fast communication with a microcontroller that is connected to the port pins and RSTZ for synchronization. A Channel-Access Write can be terminated at any time with a 1-Wire Reset.

### Figure 10. CHANNEL-ACCESS WRITE TIMING



#### Note:

Both examples assume that the RSTZ pin is configured as  $\overline{\text{STRB}}$  output. If RSTZ is configured as  $\overline{\text{RST}}$  input (default), the RSTZ pin needs to be tied high (to  $V_{CC}$  or  $V_{PUP}$ ) for the Channel-Access Write to function properly. Leaving the pin unconnected will force the output transistors of the PIO channels to the "off" state and the PIO output latches will all read "1". See Figure 6 for a schematic of the logic.

After the command code the master transmits a byte that determines the new state of the PIO output transistors. The first (least significant) bit is associated to P0. To switch the output transistor off (non-conducting) the corresponding bit value is 1. To switch the transistor on that bit needs to be 0. This way the data byte transmitted as the new PIO output state arrives in its true form at the PIO pins. To protect the transmission against data errors, the master has to repeat the new PIO byte in its inverted form. Only if the transmission was successful will the PIO status change. The actual transition at the PIO to the new state occurs during the last (most significant) bit of the inverted new PIO data byte and depends on the polarity of that bit, as shown in Figure 10. If this bit is a 1, the transition begins after  $t_{SLS}$  is expired; in case of a 0, the transition begins at the end of the time slot, when the  $V_{TH}$  threshold is crossed. To inform the master about the successful change of the PIO status, the DS2408 transmits a confirmation byte with

the data pattern AAh. If the RSTZ pin is configured as  $\overline{\text{STRB}}$ , a strobe signal will be generated during the transmission of the first two (least significant) bits of the confirmation byte. The strobe can signal a FIFO or a microcontroller to read the new data byte from the PIO. While the last bit of the confirmation byte is transmitted, the DS2408 samples the status of the PIO pins, as shown in Figure 9, and sends it to the master. Depending on the data, the master can either continue writing more data to the PIO or issue a 1-Wire reset to end the command.

## Write Conditional Search Register [CCh]

This command is used to tell the DS2408 the conditions that need to be met for the device to respond to a Conditional Search command, to define the function of the RSTZ pin and to clear the power-on reset flag.

After issuing the command the master sends the 2-byte target address, which must be a value between 008Bh and 008Dh. Next the master sends the byte to be written to the addressed cell. If the address was valid, the byte is immediately written to its location in the register page. The master now can either end the command by issuing a 1-Wire reset or send another byte for the next higher address. Once register address 008Dh has been written, any subsequent data bytes will be ignored. The master has to send a 1-Wire reset to end the command. Since the Write Conditional Search Register flow does not include any error-checking for the new register data, it is important to verify correct writing by reading the registers using the Read PIO Registers command.

## Reset Activity Latches [C3h]

Each PIO channel includes an activity latch that is set whenever there is a state transition at a PIO pin. This change may be caused by an external event/signal or by writing to the PIO. Depending on the application there may be a need to reset the activity latch after having captured and serviced an external event. Since there is only read access to the PIO Activity Latch State Register, the DS2408 supports a special command to reset the latches. After having received the command code, the device resets all activity latches simultaneously. There are two ways for the master to verify the execution of the Reset Activity Latches command. The easiest way is to start reading from the 1-Wire line right after the command code is transmitted. In this case the master will read AAh bytes until it sends a 1-Wire reset. The other way to verify execution is to read register address 008Ah.

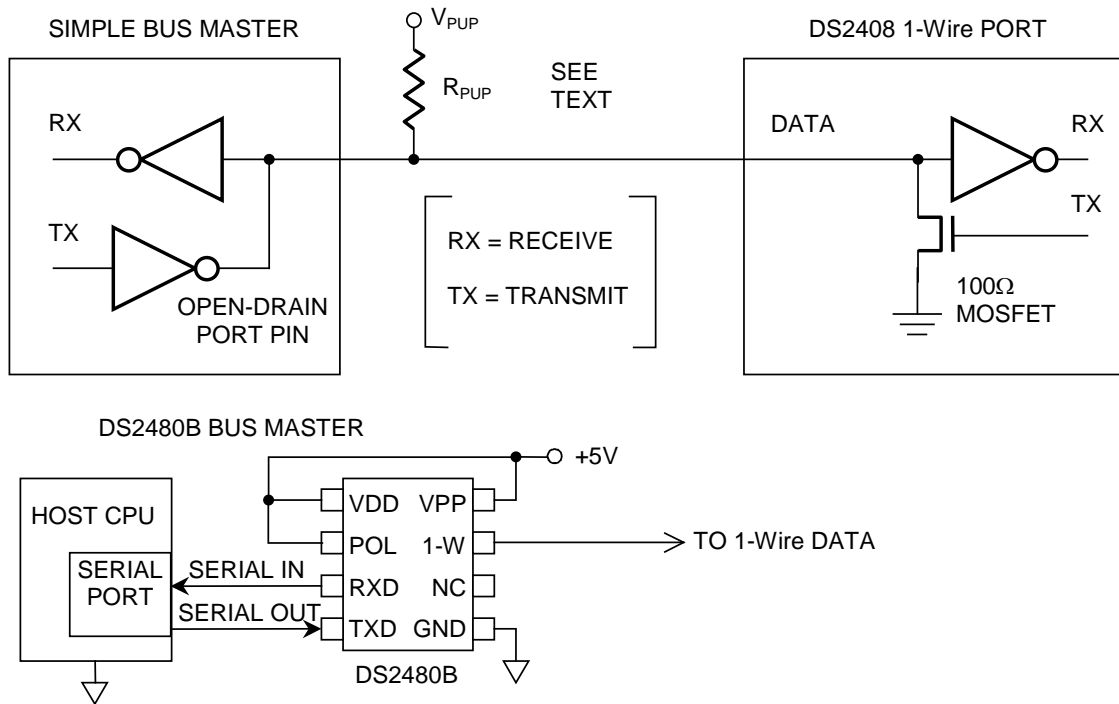
## 1-WIRE BUS SYSTEM

The 1-Wire bus is a system that has a single bus master and one or more slaves. In all instances the DS2408 is a slave device. The bus master is typically a microcontroller or PC. For small configurations the 1-Wire communication signals can be generated under software control using a single port pin. For multisensor networks, the DS2480B 1-Wire line driver chip or serial port adapters based on this chip (DS9097U series) are recommended. This simplifies the hardware design and frees the microprocessor from responding in real time.

The discussion of this bus system is broken down into three topics: hardware configuration, transaction sequence, and 1-Wire signaling (signal types and timing). The 1-Wire protocol defines bus transactions in terms of the bus state during specific time slots that are initiated on the falling edge of sync pulses from the bus master.

## HARDWARE CONFIGURATION

The 1-Wire bus has only a single line by definition; it is important that each device on the bus be able to drive it at the appropriate time. To facilitate this, each device attached to the 1-Wire bus must have open drain or tri-state outputs. The 1-Wire port of the DS2408 is open-drain with an internal circuit equivalent to that shown in Figure 11.

**Figure 11. HARDWARE CONFIGURATION**

A multidrop bus consists of a 1-Wire bus with multiple slaves attached. At standard speed the 1-Wire bus has a maximum data rate of 15.3kbps. Communication speed for 1-Wire devices can be typically boosted to 142kbps by activating the overdrive mode; however, the maximum overdrive data rate for the DS2408 is 100kbps. The value of the pullup resistor primarily depends on the network size and load conditions. For most applications the optimal value of the pullup resistor will be approximately  $2.2k\Omega$  for standard speed and  $1.5k\Omega$  for overdrive speed.

The idle state for the 1-Wire bus is high. If for any reason a transaction needs to be suspended, the bus **MUST** be left in the idle state if the transaction is to resume. If this does not occur and the bus is left low for more than  $16\mu s$  (overdrive speed) or more than  $120\mu s$  (standard speed), one or more devices on the bus may be reset. With the DS2408 the bus must be left low for no longer than  $13\mu s$  at overdrive speed to ensure that none of the slave devices on the 1-Wire bus performs a reset. The DS2408 communicates properly when used in conjunction with a DS2480B 1-Wire driver and serial port adapters that are based on this driver chip. When operating the device in overdrive or below 4.5V, some 1-Wire I/O timing values must be modified (see EC table).

## TRANSACTION SEQUENCE

The protocol for accessing the DS2408 through the 1-Wire port is as follows:

- Initialization
- ROM Function Command
- Control Function Command
- Transaction/Data

Illustrations of the transaction sequence for the various control function commands are found later in this document.

## INITIALIZATION

All transactions on the 1-Wire bus begin with an initialization sequence. The initialization sequence consists of a reset pulse transmitted by the bus master followed by presence pulse(s) transmitted by the slave(s). The presence pulse lets the bus master know that the DS2408 is on the bus and is ready to operate. For more details, see the 1-Wire Signaling section.

## ROM FUNCTION COMMANDS

Once the bus master has detected a presence, it can issue one of the seven ROM function commands. All ROM function commands are eight bits long. A list of these commands follows (see the flowchart in Figure 12).

### Read ROM [33h]

This command allows the bus master to read the DS2408's 8-bit family code, unique 48-bit serial number, and 8-bit CRC. This command can only be used if there is a single device on the bus. If more than one slave is present on the bus, a data collision will occur when all slaves try to transmit at the same time (open drain will produce a wired-AND result). The resultant family code and 48-bit serial number will result in a mismatch of the CRC.

### Match ROM [55h]

The Match ROM command, followed by a 64-bit ROM sequence, allows the bus master to address a specific DS2408 on a multidrop bus. Only the DS2408 that exactly matches the 64-bit ROM sequence will respond to the following control function command. All slaves that do not match the 64-bit ROM sequence will wait for a reset pulse. This command can be used with either single or multiple devices on the bus.

### Search ROM [F0h]

When a system is initially brought up, the bus master might not know the number of devices on the 1-Wire bus or their 64-bit ROM codes. The Search ROM command allows the bus master to use a process of elimination to identify the 64-bit ROM codes of all slave devices on the bus. The search ROM process is the repetition of a simple three-step routine: read a bit, read the complement of the bit, then write the desired value of that bit. The bus master performs this simple, three-step routine on each bit of the ROM. After one complete pass, the bus master knows the contents of the ROM in one device. The remaining number of devices and their ROM codes may be identified by additional passes. See *Application Note 187* for a detailed discussion on the Search ROM command process including a software example.

### Conditional Search [ECh]

The Conditional Search ROM command operates similarly to the Search ROM command except that only devices fulfilling the specified condition will participate in the search. The condition is specified by the Conditional Search channel and polarity selection (addresses 008Bh, 008Ch), the bit functions CT and

PLS of the Control/Status Register (address 008Dh), and the state of the PIO channels. See Figure 7 for a description of the Conditional Search logic. The device also responds to the Conditional Search if the PORL bit is set. The Conditional Search ROM provides an efficient means for the bus master to determine devices on a multidrop system that have to signal an important event, such as a state change at a PIO pin caused by an external signal. After each pass of the conditional search that successfully determined the 64-bit ROM for a specific device on the multidrop bus, that particular device can be individually accessed as if a Match ROM had been issued, since all other devices will have dropped out of the search process and will be waiting for a reset pulse.

### **Skip ROM [CCh]**

This command can save time in a single-drop bus system by allowing the bus master to access the control functions without providing the 64-bit ROM code. If more than one slave is present on the bus and a Read command is issued following the Skip ROM command, data collision will occur on the bus as multiple slaves transmit simultaneously (open-drain pulldowns will produce a wired-AND result).

### **Resume Command [A5h]**

In a typical application the DS2408 can be accessed several times to complete a control or adjustment function. In a multidrop environment this means that the 64-bit ROM sequence of a Match ROM command has to be repeated for every access. To maximize the data throughput in a multidrop environment, the Resume Command function is implemented. This function checks the status of the RC flag and, if it is set, directly transfers control to the control functions, similar to a Skip ROM command. The only way to set the RC flag is through successfully executing the Match ROM, Search ROM, Conditional Search ROM, or Overdrive-Match ROM command. Once the RC flag is set, the device can be repeatedly accessed through the Resume Command function. Accessing another device on the bus will clear the RC flag, preventing two or more devices from simultaneously responding to the Resume Command function.

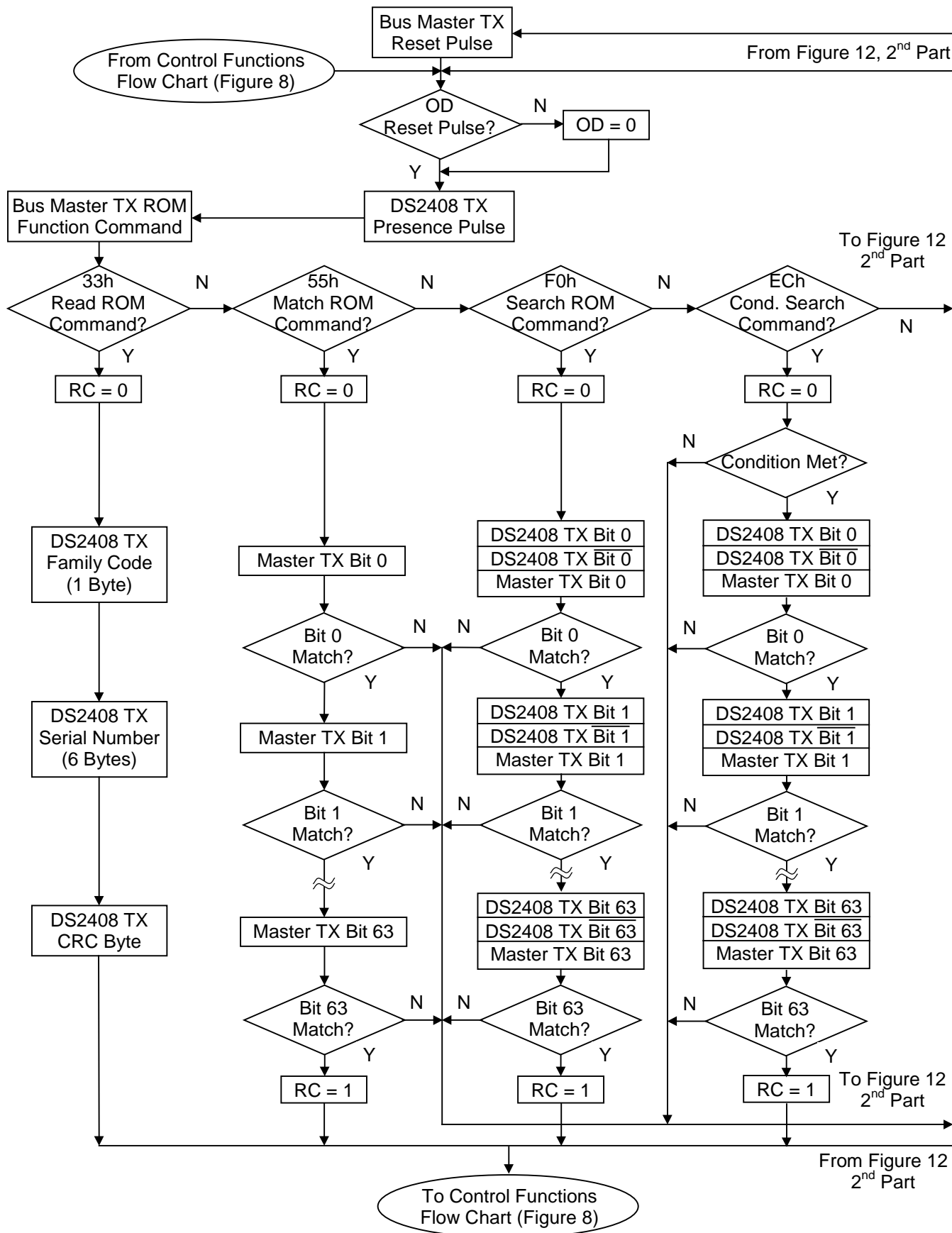
### **Skip ROM [3Ch]**

On a single-drop bus this command can save time by allowing the bus master to access the control functions without providing the 64-bit ROM code. Unlike the normal Skip ROM command, the Overdrive Skip ROM sets the DS2408 in the overdrive mode ( $OD = 1$ ). All communication following this command has to occur at overdrive speed until a reset pulse of minimum 480 $\mu$ s duration resets all devices on the bus to standard speed ( $OD = 0$ ). When issued on a multidrop bus this command will set all overdrive-supporting devices into overdrive mode. To subsequently address a specific overdrive-supporting device, a reset pulse at overdrive speed has to be issued followed by a Match ROM or Search ROM command sequence. This will speed up the time for the search process. If more than one slave supporting overdrive is present on the bus and the Overdrive Skip ROM command is followed by a Read command, data collision will occur on the bus as multiple slaves transmit simultaneously (open-drain pulldowns will produce a wired-AND result).

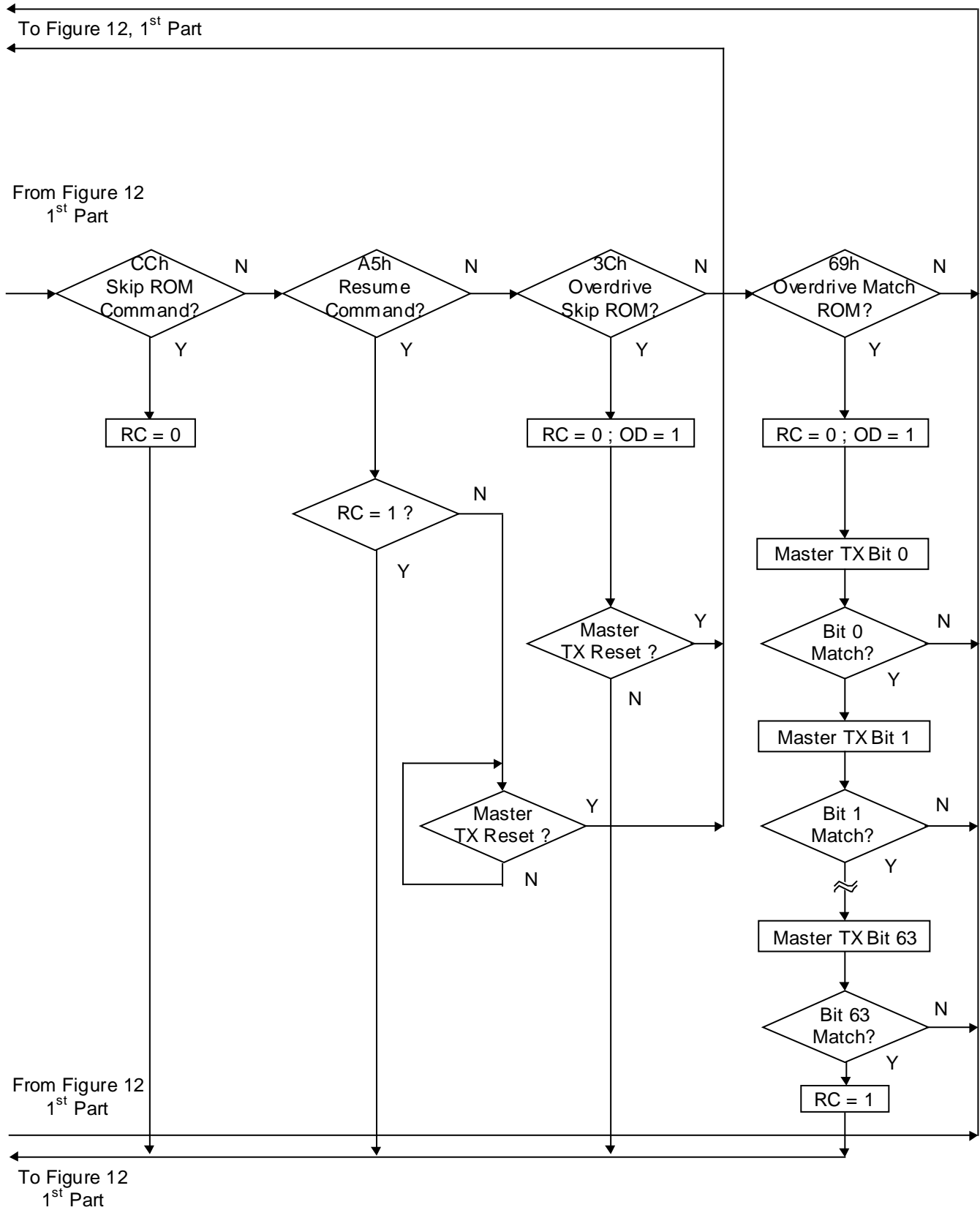
### **Overdrive Match ROM [69h]**

The Overdrive Match ROM command followed by a 64-bit ROM sequence transmitted at overdrive speed allows the bus master to address a specific DS2408 on a multidrop bus and to simultaneously set it in overdrive mode. Only the DS2408 that exactly matches the 64-bit ROM sequence will respond to the subsequent control function command. Slaves already in overdrive mode from a previous Overdrive Skip or Match command will remain in overdrive mode. All overdrive-capable slaves will return to standard speed at the next Reset Pulse of minimum 480 $\mu$ s duration. The Overdrive Match ROM command can be used with either single or multiple devices on the bus.

**Figure 12-1. ROM FUNCTIONS FLOW CHART**



**Figure 12-2. ROM FUNCTIONS FLOW CHART**



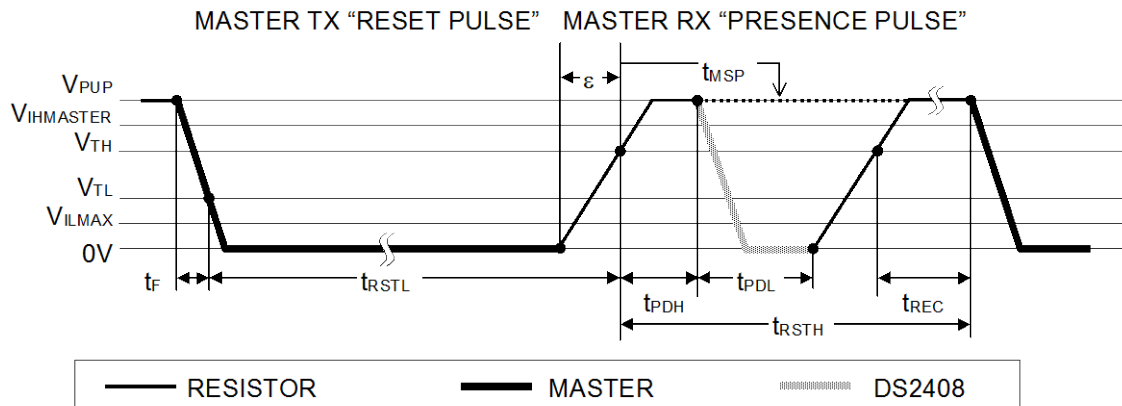
## 1-WIRE SIGNALING

The DS2408 requires strict protocols to ensure data integrity. The protocol consists of four types of signaling on one line: Reset Sequence with Reset Pulse and Presence Pulse, Write-Zero, Write-One, and Read-Data. Except for the presence pulse, the bus master initiates all these signals. The DS2408 can communicate at two different speeds, standard speed, and overdrive speed. If not explicitly set into the overdrive mode, the DS2408 will communicate at standard speed. While in overdrive mode, the fast timing applies to all waveforms.

To get from idle to active, the voltage on the 1-Wire line needs to fall from  $V_{PUP}$  below the  $V_{TL}$  threshold. To get from active to idle, the voltage needs to rise from  $V_{ILMAX}$  past the  $V_{TH}$  threshold. The  $V_{ILMAX}$  voltage is relevant for the DS2408 when determining a logical level, not triggering any events.

Figure 13 shows the initialization sequence required to begin any communication with the DS2408. A Reset Pulse followed by a Presence Pulse indicates the DS2408 is ready to receive data, given the correct ROM and control function command. If the bus master uses slew-rate control on the falling edge, it must pull down the line for  $t_{RSTL} + t_F$  to compensate for the edge. A  $t_{RSTL}$  duration of 480 $\mu$ s or longer will exit the overdrive mode returning the device to standard speed. If the DS2408 is in overdrive mode and  $t_{RSTL}$  is no longer than 80 $\mu$ s the device will remain in overdrive mode.

**Figure 13. INITIALIZATION PROCEDURE “RESET AND PRESENCE PULSES”**



After the bus master has released the line it goes into receive mode (RX). The 1-Wire bus is then pulled to  $V_{PUP}$  via the pullup resistor or, in case of a DS2480B driver, by active circuitry. When the  $V_{TH}$  threshold is crossed, the DS2408 waits for  $t_{PDH}$  and then transmits a Presence Pulse by pulling the line low for  $t_{PDL}$ . To detect a presence pulse, the master must test the logical state of the 1-Wire line at  $t_{MSP}$ .

The  $t_{RSTH}$  window must be at least the sum of  $t_{PDHMAX}$ ,  $t_{PDLMAX}$ , and  $t_{RECMIN}$ . Immediately after  $t_{RSTH}$  is expired, the DS2408 is ready for data communication. In a mixed population network,  $t_{RSTH}$  should be extended to a minimum of 480 $\mu$ s at standard speed and 48 $\mu$ s at overdrive speed to accommodate other 1-Wire devices.

## Read/Write Time Slots

Data communication with the DS2408 takes place in time slots, which carry a single bit each. Write time slots transport data from bus master to slave. Read time slots transfer data from slave to master. The definitions of the write and read time slots are illustrated in Figure 14.

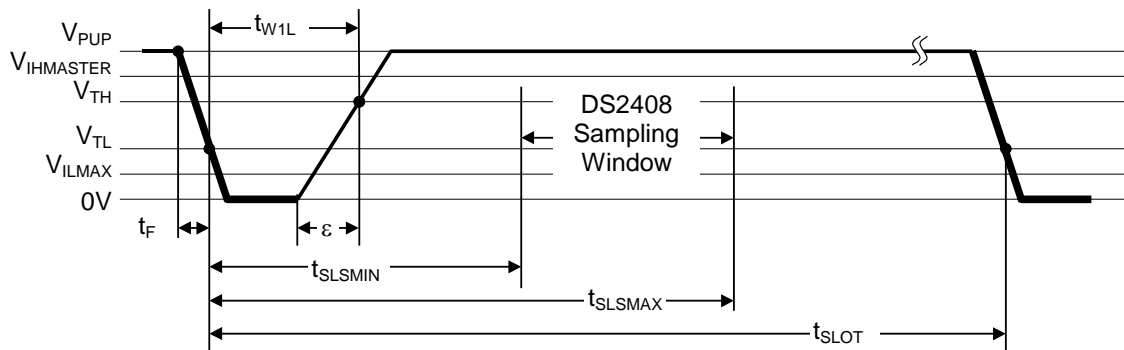
All communication begins with the master pulling the data line low. As the voltage on the 1-Wire line falls below the threshold  $V_{TL}$ , the DS2408 starts its internal time base. The tolerance of the slave time base creates a slave-sampling window, which stretches from  $t_{SLSMIN}$  to  $t_{SLSMAX}$ . The voltage on the data line at the sampling point determines whether the DS2408 decodes the time slot as 1 or 0.

## Master-to-Slave

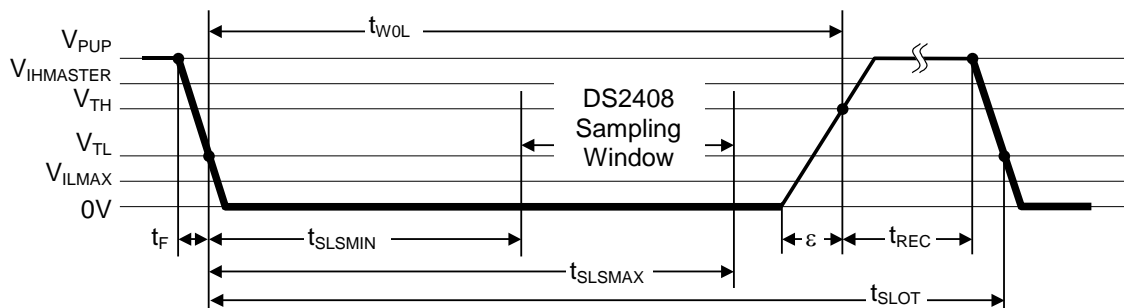
For a write-one time slot, the voltage on the data line must have crossed the  $V_{THMAX}$  threshold after the write-one low time  $t_{W1LMAX}$  has expired. For a write-zero time slot, the voltage on the data line must stay below the  $V_{THMIN}$  threshold until the write-zero low time  $t_{W0LMAX}$  has expired. For most reliable communication, the voltage on the data line should not exceed  $V_{ILMAX}$  during the entire  $t_{W0L}$  window. After the  $V_{THMAX}$  threshold has been crossed, the DS2408 needs a recovery time  $t_{REC}$  before it is ready for the next time slot.

**Figure 14. READ/WRITE TIMING DIAGRAM**

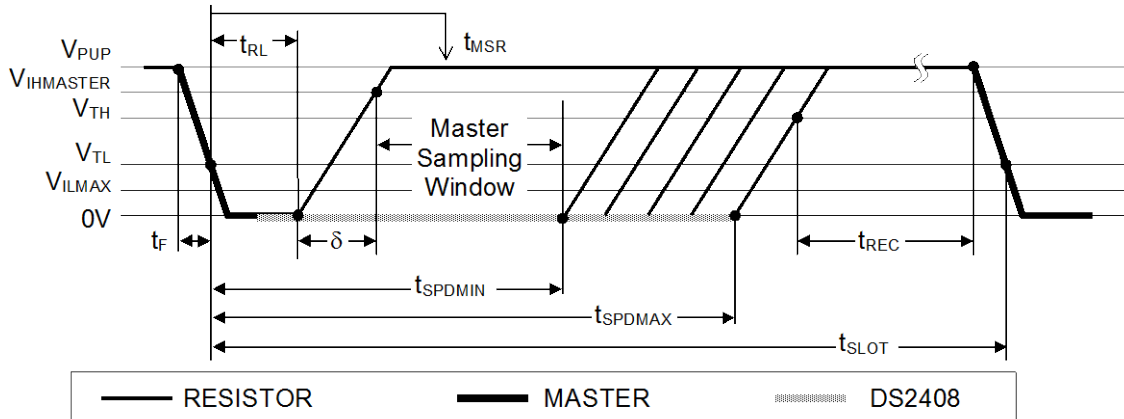
### Write-One Time Slot



### Write-Zero Time Slot



## Read-Data Time Slot



## Slave-to-Master

A read-data time slot begins like a write-one time slot. The voltage on the data line must remain below  $V_{TLMIN}$  until the read low time  $t_{RL}$  has expired. During the  $t_{RL}$  window, when responding with a 0, the DS2408 starts pulling the data line low; its internal timing generator determines when this pulldown ends and the voltage starts rising again. When responding with a 1, the DS2408 does not hold the data line low at all, and the voltage starts rising as soon as  $t_{RL}$  is over.

The sum of  $t_{RL} + \delta$  (rise time) on one side and the internal timing generator of the DS2408 on the other side define the master sampling window ( $t_{MSRMIN}$  to  $t_{MSRMAX}$ ) in which the master must perform a read from the data line. For most reliable communication,  $t_{RL}$  should be as short as permissible and the master should read close to but no later than  $t_{MSRMAX}$ . After reading from the data line, the master must wait until  $t_{SLOT}$  is expired. This guarantees sufficient recovery time  $t_{REC}$  for the DS2408 to get ready for the next time slot.

## Improved Network Behavior

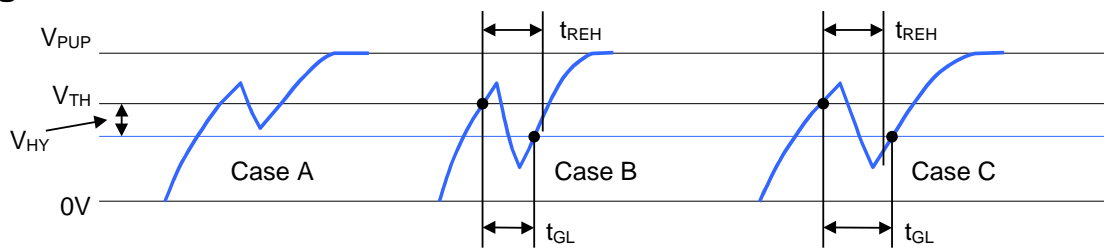
In a 1-Wire environment, line termination is possible only during transients controlled by the bus master (1-Wire driver). 1-Wire networks therefore are susceptible to noise of various origins. Depending on the physical size and topology of the network, reflections from end points and branch points can add up or cancel each other to some extent. Such reflections are visible as glitches or ringing on the 1-Wire communication line. Noise coupled onto the 1-Wire line from external sources can also result in signal glitching. A glitch during the rising edge of a time slot can cause a slave device to lose synchronization with the master and, as a consequence, result in a Search ROM command coming to a dead end or cause a device level command to abort. For better performance in network applications, the DS2408 uses a new 1-Wire front end, which makes it less sensitive to noise and also reduces the magnitude of noise injected by the slave device itself.

The 1-Wire front end of the DS2408 differs from traditional slave devices in four characteristics.

- 1) The falling edge of the presence pulse has a controlled slew rate. This provides a better match to the line impedance than a digitally switched transistor, converting the high-frequency ringing known from traditional devices into a smoother low-bandwidth transition. The slew rate control is specified by the parameter  $t_{FPD}$ , which has different values for standard and overdrive speed.
- 2) There is additional lowpass filtering in the circuit that detects the falling edge at the beginning of a time slot. This reduces the sensitivity to high-frequency noise. This additional filtering does not apply at overdrive speed.

- 3) The input buffer was designed with hysteresis. If a negative glitch crosses  $V_{TH}$  but doesn't go below  $V_{TH} - V_{HY}$ , it will not be recognized (Figure 15, Case A). The hysteresis is effective at any 1-Wire speed.
- 4) There is a time window specified by the rising edge hold-off time  $t_{REH}$  during which glitches will be ignored, even if they extend below the  $V_{TH} - V_{HY}$  threshold (Figure 15, Case B,  $t_{GL} < t_{REH}$ ). Deep voltage droops or glitches that appear late after crossing the  $V_{TH}$  threshold and extend beyond the  $t_{REH}$  window cannot be filtered out and will be taken as the beginning of a new time slot (Figure 15, Case C,  $t_{GL} \geq t_{REH}$ ).

**Figure 15. NOISE SUPPRESSION SCHEME**



## CRC GENERATION

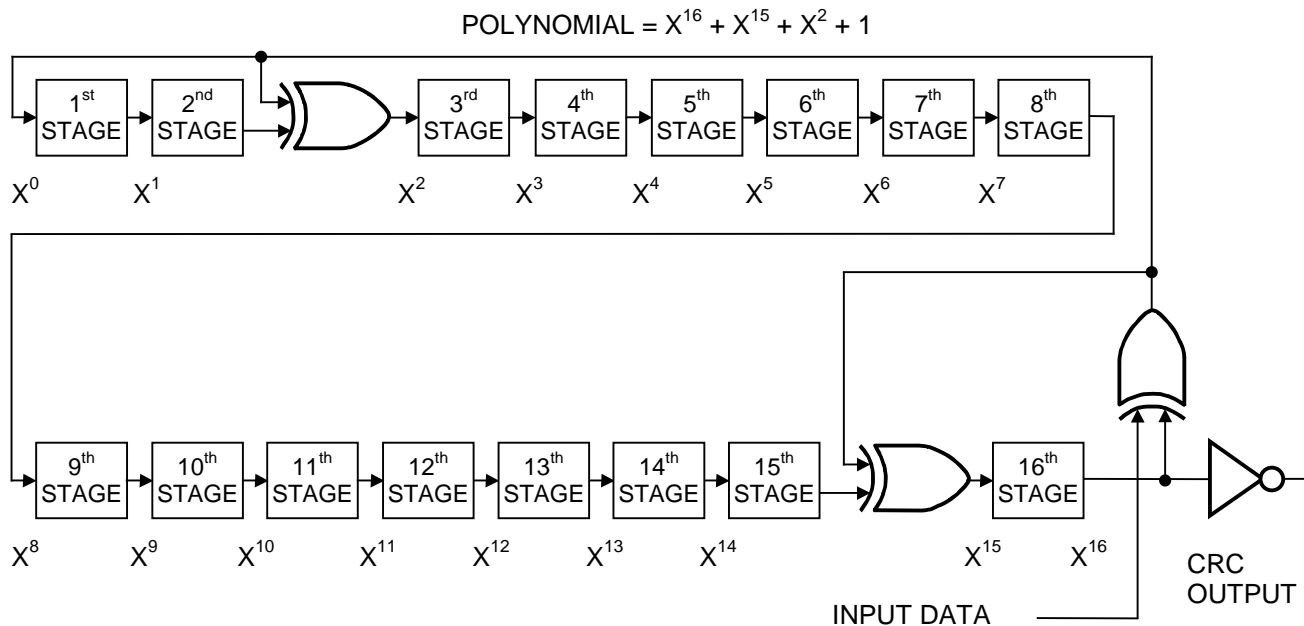
The DS2408 has two different types of cyclic redundancy checks (CRCs). One CRC is an 8-bit type and is stored in the most significant byte of the 64-bit ROM. The bus master can compute a CRC value from the first 56 bits of the 64-bit ROM and compare it to the value stored within the DS2408 to determine if the ROM data has been received error free. The equivalent polynomial function of this CRC is  $X^8 + X^5 + X^4 + 1$ . This 8-bit CRC is received in the true (noninverted) form. It is computed at the factory and lasered into the ROM.

The other CRC is a 16-bit type, generated according to the standardized CRC16-polynomial function  $X^{16} + X^{15} + X^2 + 1$ . This CRC is used for error detection when reading data through the end of the register page using the Read PIO Registers command, for fast verification of the data transfer when writing to or reading from the scratchpad, and when reading from the PIO using the Channel-access Read command. In contrast to the 8-bit CRC, the 16-bit CRC is always communicated in the inverted form. A CRC-generator inside the DS2408 chip (Figure 16) calculates a new 16-bit CRC as shown in the command flow chart of Figure 8. The bus master compares the CRC value read from the device to the one it calculates from the data and decides whether to continue with an operation or to reread the portion of the data with the CRC error.

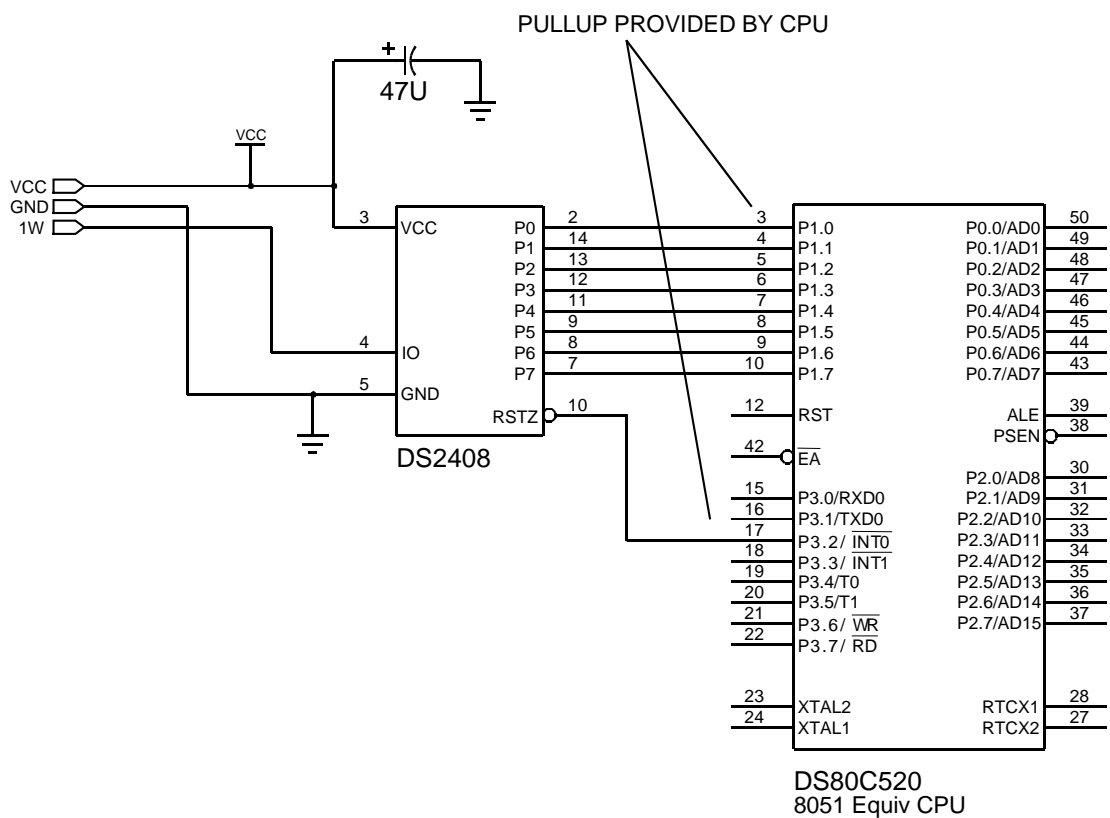
With the Read PIO Registers flow chart, the 16-bit CRC value is the result of shifting the command byte into the cleared CRC generator, followed by the 2 address bytes and the data bytes beginning at the target address and ending with the last byte of the register page, address 008Fh.

With the initial pass through the Channel-access Read command flow, the CRC is generated by first clearing the CRC generator and then shifting in the command code followed by 32 bytes of PIO pin data. Subsequent passes through the command flow will generate a 16-bit CRC that is the result of clearing the CRC generator and then shifting in 32 bytes read from the PIO pins. For more information on generating CRC values see *Application Note 27*.

**Figure 16. CRC-16 HARDWARE DESCRIPTION AND POLYNOMIAL**



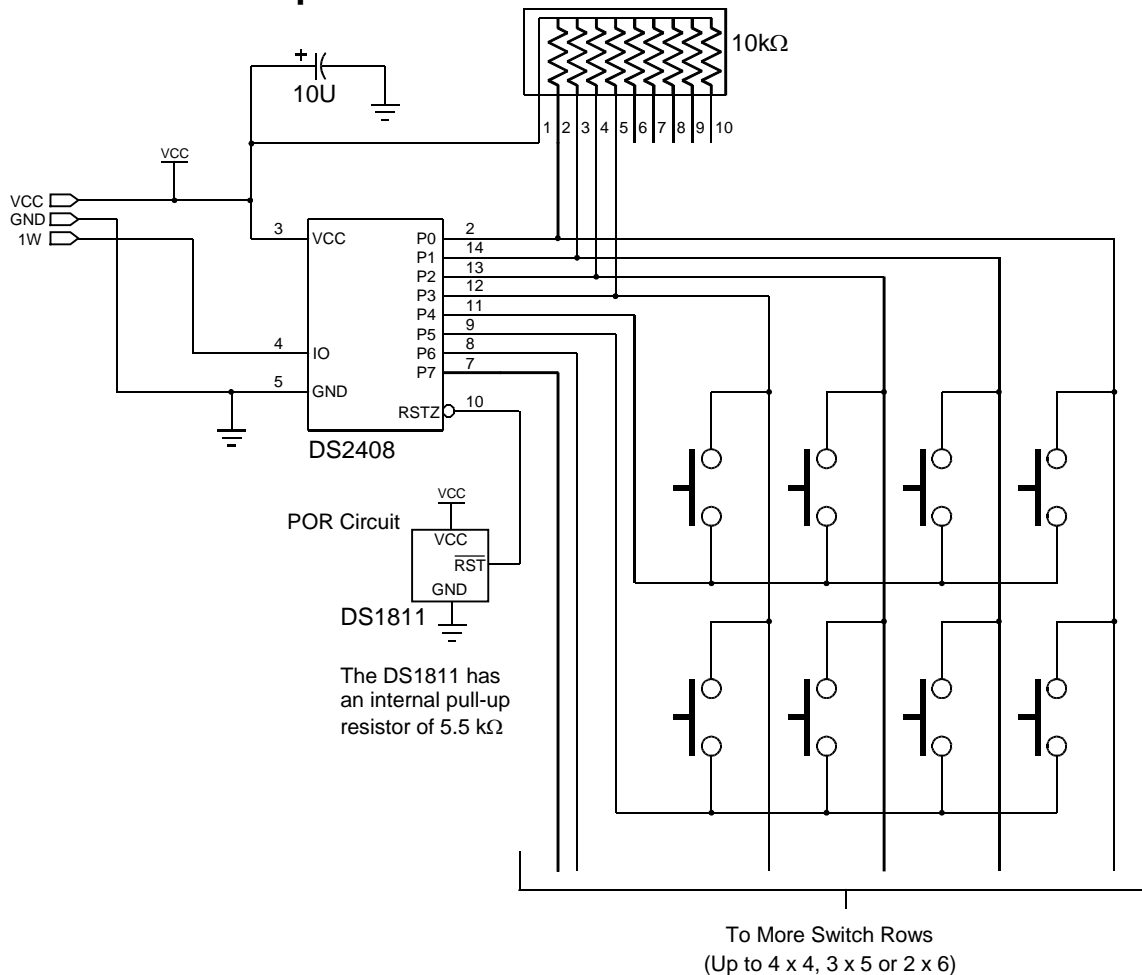
**Figure 17. DS2408 AS SLAVE INTERFACE FOR MICROCONTROLLER**



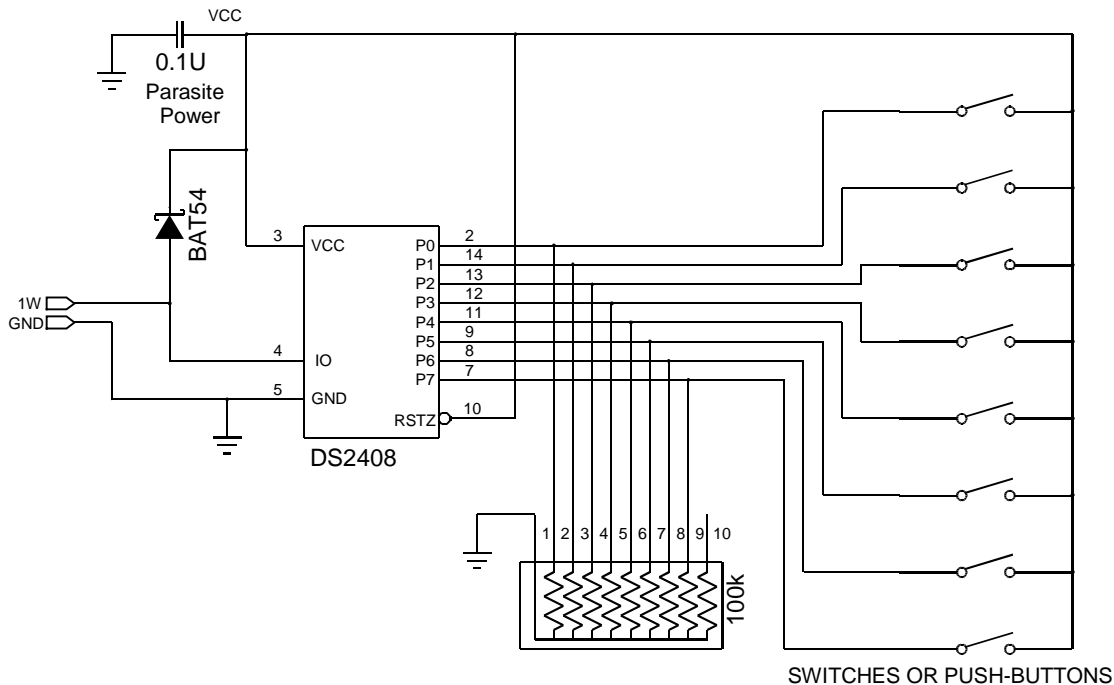
The data direction (upload/download) is determined by application-specific data protocol.



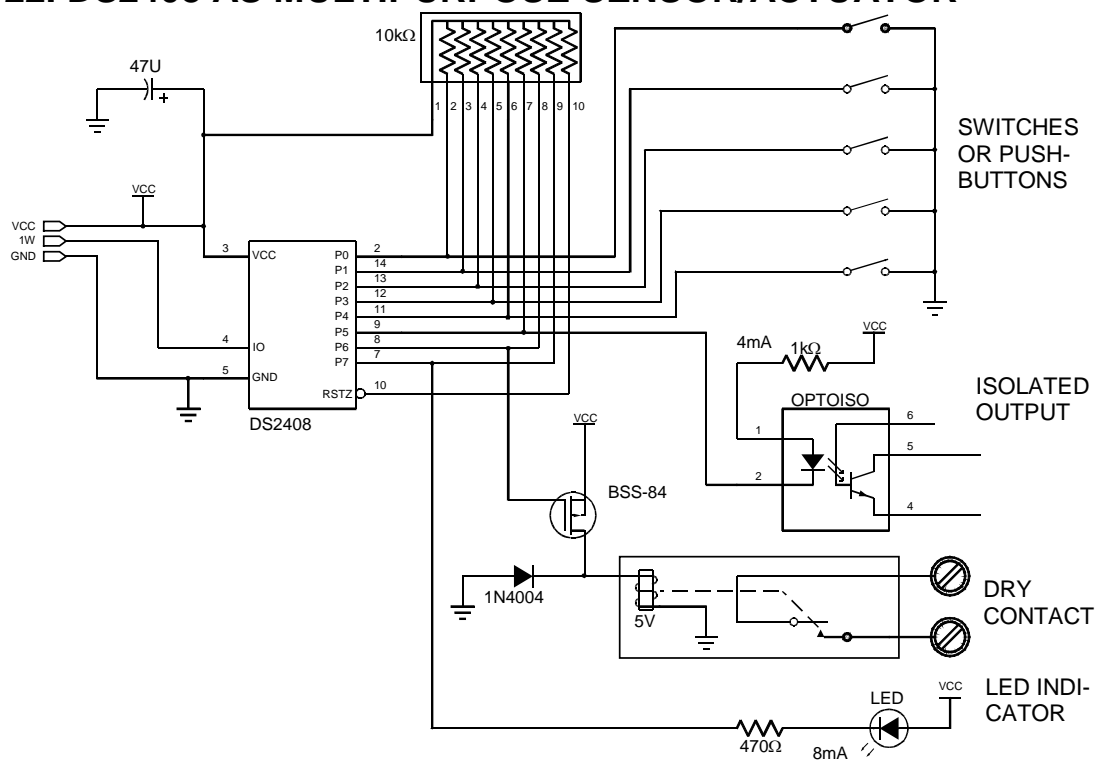
**Figure 20. DS2408 AS  $\mu$ C-OPERATED KEYBOARD SCANNER**



**Figure 21. DS2408 AS PARASITE-POWERED PUSH-BUTTON SENSOR**



# Figure 22. DS2408 AS MULTIPURPOSE SENSOR/ACTUATOR



## Command-Specific 1-Wire Communication Protocol—Legend

SYMBOL	DESCRIPTION
RST	1-Wire Reset Pulse generated by master.
PD	1-Wire Presence Pulse generated by slave.
Select	Command and data to satisfy the ROM function protocol.
RPR	Command "Read PIO Registers".
CAR	Command "Channel-Access Read".
CAW	Command "Channel-Access Write".
WCS	Command "Write Conditional Search Register".
RAL	Command "Reset Activity Latches".
TA	Target Address TA1, TA2.
<data>	Transfer of an undetermined amount of data.
CRC16\	Transfer of an inverted CRC16.
FF loop	Indefinite loop where the master reads FF bytes.
AA loop	Indefinite loop where the master reads AA bytes.
<32 samples>, CRC16\ loop	Indefinite loop where the master reads 32 PIO samples followed by an inverted CRC16.
<new state>, <new state\>	Transfer of 2 bytes, where the second byte is the bit-inverse of the first byte. The first byte will be taken as the new PIO state.
AAh, <read back>	Transfer of 2 bytes, where the first byte is a constant (AAh) and the second byte is the current PIO state.
<new state>, <invalid>	Transfer of 2 bytes, where the second byte is NOT the bit-inverse of the first byte.

## Command-Specific 1-Wire Communication Protocol—Color Codes

Master to slave	Slave to master
-----------------	-----------------

### Read PIO Registers (Success)

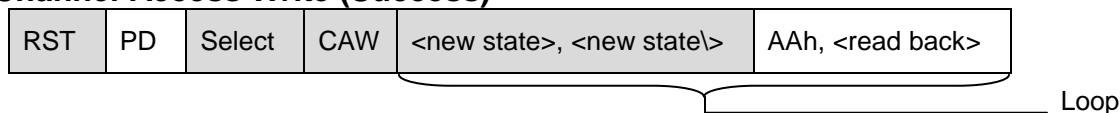
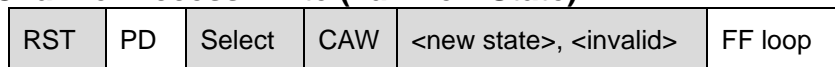
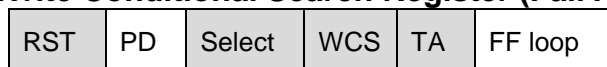
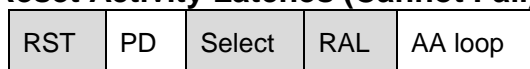
RST	PD	Select	RPR	TA	<data>	CRC16\	FF loop
-----	----	--------	-----	----	--------	--------	---------

### Read PIO Registers (Fail Address)

RST	PD	Select	RPR	TA	FF loop
-----	----	--------	-----	----	---------

### Channel-Access Read (Cannot Fail)

RST	PD	Select	CAR	<32 samples>, CRC16\ loop
-----	----	--------	-----	---------------------------

**Channel-Access Write (Success)****Channel-Access Write (Fail New State)****Write Conditional Search Register (Success)****Write Conditional Search Register (Fail Address)****Reset Activity Latches (Cannot Fail)****COMMUNICATION EXAMPLES**

The examples in this section demonstrate the use of ROM and control functions in typical situations. The first two examples are related to Figure 17. They show how to write to the PIO with readback for verification or for receiving an immediate response (example 1) and how to read from the PIO in an endless loop (example 2). The third example assumes a network of multiple DS2408s where each of the devices is connected to 8 pushbuttons, as in Figure 21.

**Example 1**

**Task:** Write to the PIO with readback for verification or for receiving an immediate response.

This task is broken into the following steps:

- 1) Configure RSTZ as  $\overline{\text{STRB}}$  output.
- 2) Verify configuration setting.
- 3) Write to the PIO and read back the response.

With only a single DS2408 connected to the bus master, the communication is as follows:

MASTER MODE		DATA (LSB FIRST)	COMMENTS
Step 1	TX	(Reset)	Reset pulse
	RX	(Presence)	Presence pulse
	TX	CCh	Issue Skip ROM command
	TX	CCh	Issue Write Conditional Search Register command
	TX	8Dh	TA1, target address = 8Dh
	TX	00h	TA2, target address = 008Dh
	TX	04h	Write byte to Control/Status Register

MASTER MODE		DATA (LSB FIRST)	COMMENTS
	TX	(Reset)	Reset pulse
	RX	(Presence)	Presence pulse
Step 2	TX	CCh	Issue Skip ROM command
	TX	F0h	Issue Read PIO Registers command
	TX	8Dh	TA1, target address = 8Dh
	TX	00h	TA2, target address = 008Dh
	RX	84h	Read Control/Status Register and verify
	TX	(Reset)	Reset pulse
	RX	(Presence)	Presence pulse
Step 3	TX	CCh	Issue Skip ROM command
	TX	5Ah	Issue Channel-access Write command
	TX	<PIO output byte>	Write byte to PIO
	TX	<inverted PIO output byte>	Write inverted byte to PIO
	(—)	(—)	DS2408 updates PIO status if transmission was OK
	RX	AAh	Read for verification (AAh = success)
	(—)	(—)	DS2408 samples PIO pin status
	RX	<PIO pin status byte>	Read PIO pin status
	TX	<PIO output byte>	Write byte to PIO (next byte)
	TX	<inverted PIO output byte>	Write inverted byte to PIO (next byte)
	RX	AAh	Read for verification (AAh = success)
	RX	<PIO pin status byte>	Read PIO pin status
	(—)	(—)	Repeat the previous 4 steps with more PIO output data as needed in the application.
	TX	(Reset)	Reset pulse
	RX	(Presence)	Presence pulse

When using this communication example to send data to a remote microcontroller, as in Figure 17, synchronization between the master and the remote microcontroller can be maintained by transmitting data packets that begin with a length byte and end with a CRC16. See *Application Note 114*, section "UNIVERSAL DATA PACKET" for details.

## Example 2

**Task:** Read from the PIO in an endless loop.

This task is broken into the following steps:

- 1) Configure RSTZ as  $\overline{\text{STRB}}$  output.
- 2) Verify configuration setting.
- 3) Read from the PIO.

With only a single DS2408 connected to the bus master, the communication is as follows:

MASTER MODE		DATA (LSB FIRST)	COMMENTS
Step 1	TX	(Reset)	Reset pulse
	RX	(Presence)	Presence pulse
	TX	CCh	Issue Skip ROM command
	TX	CCh	Issue Write Conditional Search Register command
	TX	8Dh	TA1, target address = 8Dh
	TX	00h	TA2, target address = 008Dh

MASTER MODE	DATA (LSB FIRST)	COMMENTS	
	04h	Write byte to Control/Status Register	
	(Reset)	Reset pulse	
	(Presence)	Presence pulse	
Step 2	TX	CCh	Issue Skip ROM command
	TX	F0h	Issue Read PIO Registers command
	TX	8Dh	TA1, target address = 8Dh
	TX	00h	TA2, target address = 008Dh
	RX	84h	Read Control/Status Register and verify
	TX	(Reset)	Reset pulse
	RX	(Presence)	Presence pulse
Step 3	TX	CCh	Issue Skip ROM command
	TX	F5h	Issue Channel-access Read command
	(—)	(—)	DS2408 samples PIO pin status
	RX	<PIO pin status byte>	Read PIO pin status
	(—)	(—)	Repeat the previous 2 steps until the master has received a total of 32 bytes of PIO pin status
	RX	<2 bytes CRC16>	Read CRC16
	(—)	(—)	PIO pin status and CRC loop can be continued as long as the application requires.
	TX	(Reset)	Reset pulse
	RX	(Presence)	Presence pulse

When using this communication example to read data from a remote microcontroller, as in Figure 17, synchronization between the remote microcontroller and the master can be maintained by transmitting data packets that begin with a length byte and end with a CRC16. See *Application Note 114*, section "UNIVERSAL DATA PACKET" for details.

### Example 3

**Task:** Detect the specific DS2408 where the button was pressed and identify the pin to which the pushbutton is connected. This task is broken into the following steps:

- 1) Configure the conditional search and verify configuration setting.
- 2) Switch off all channel output transistors.
- 3) Clear the activity latches.
- 4) Search until a pushbutton is pressed.
- 5) Identify device and pushbutton; reset activity latches.

The device has to respond to the conditional search if the activity latch of at least one of the 8 channels is set. This requires the following setup data for the conditional search registers:

**Channel Selection Mask**, select all channels ⇒ FFh

**Channel Polarity Selection**, select logic 1 for all channels ⇒ FFh

**Control/Status register,**

Source is Activity Latch  $\Rightarrow$  PLS = 1

Term is OR  $\Rightarrow$  CT = 0

RSTZ = inactive (input)  $\Rightarrow$  ROS = 0

Clear Power-On Reset Latch  $\Rightarrow$  PORL = 0

The resulting setup data for the Control/Status Register is 01h.

For each DS2408 in the application, perform the following initialization:

MASTER MODE		DATA (LSB FIRST)	COMMENTS
Step 1	TX	(Reset)	Reset pulse
	RX	(Presence)	Presence pulse
	TX	55h	Issue Match ROM command
	TX	<8 byte ROM ID>	Send ROM ID of the device to be accessed
	TX	CCh	Issue Write Conditional Search Register command
	TX	8Bh	TA1, target address = 8Bh
	TX	00h	TA2, target address = 008Bh
	TX	FFh	Write Channel Selection Mask
	TX	FFh	Write Channel Polarity Selection
	TX	01h	Write Control/Status Register
	TX	(Reset)	Reset pulse
	RX	(Presence)	Presence pulse
	TX	A5h	Issue Resume command
	TX	F0h	Issue Read PIO Registers command
	TX	8Bh	TA1, target address = 8Bh
	TX	00h	TA2, target address = 008Bh
	RX	<FFh, FFh, 81h>	Read Registers and verify
	TX	(Reset)	Reset pulse
	RX	(Presence)	Presence pulse
Step 2	TX	A5h	Issue Resume command
	TX	5Ah	Issue Channel-access Write command
	TX	FFh	Write byte to PIO
	TX	00h	Write inverted byte to PIO
	(—)	(—)	DS2408 switches off all channel output transistors if transmission was OK
	RX	AAh	Read for verification (AAh = success)
	RX	FFh	Read PIO pin status and verify; FFh = OK
	TX	(Reset)	Reset pulse
	RX	(Presence)	Presence pulse
Step 3	TX	A5h	Issue Resume command
	TX	C3	Issue Reset Activity Latch command
	RX	AAh	Read for verification (AAh = success)
	TX	(Reset)	Reset pulse
	RX	(Presence)	Presence pulse

After all DS2408s are initialized, perform the search process below as an endless loop:

MASTER MODE		DATA (LSB FIRST)	COMMENTS
Step 4	TX	(Reset)	Reset pulse
	RX	(Presence)	Presence pulse
	TX	ECh	Issue Conditional Search ROM command
	RX	<2 bits>	Read 2 bits; if both bits are 1, no push button has been pressed; in this case return to Step 4. If the bit pattern is 01 or 10 or 00, a push button has been pressed; in this case continue with Step 5.
Step 5	TX	<1 bits>	Identify and select the LS bit of the ROM ID of the DS2408 that has responded to the Conditional Search.
	RX	<2 bits>	Read 2 bits; this relates to the next bit of the ROM ID of the participating device(s).
	TX	<1 bits>	Identify and select the next bit of the ROM ID of the DS2408 that has responded to the Conditional Search.
	(—)	(—)	Repeat the previous 2 steps until one device has been identified and accessed. (see Note 1)
	TX	F0h	Issue Read PIO Registers command
	TX	88h	TA1, target address = 88h
	TX	00h	TA2, target address = 0000h
	RX	<8 data bytes>	Read register page; the data in the Activity Latch State Register tells which button has been pressed.
	RX	<2 bytes CRC16>	Read CRC16 and verify correct data transmission.
	TX	(Reset)	Reset pulse
	RX	(Presence)	Presence pulse
	TX	A5h	Issue Resume command
	TX	C3	Issue Reset Activity Latch command
	RX	AAh	Read for verification (AAh = success)
	(—)	(—)	Now, as the device and push button are identified and the Activity Latch is cleared, continue at Step 4.

**Note 1:** For a full description of the Search Algorithm see *Application Note 187*.

## APPLICATIONS INFORMATION

### Power-up timing

The DS2408 is sensitive to the power-on slew rate and can inadvertently power up with a test mode feature enabled. When this occurs, the P0 port does not respond to the *Channel Access Write* command.

For most reliable operation, it is recommended to disable the test mode **after every power-on reset** using the Disable Test Mode sequence shown below. The 64-bit ROM code must be transmitted in the same bit sequence as with the Match ROM command, i.e., least significant bit first. This precaution is recommended in parasite power mode ( $V_{CC}$  pin connected to GND) as well as with  $V_{CC}$  power.

### Disable Test Mode

RST	PD	96h	<64-bit DS2408 ROM Code>	3Ch	RST	PD
-----	----	-----	--------------------------	-----	-----	----

### Power-up State of P0 to P7

When the DS2408 powers up, the state of the I/O pins P0 to P7 is indeterminate. This behavior may not be acceptable for some applications. To ensure that P0 to P7 power up in the "off" state, it is necessary to have a suitable power-on-reset circuit, such as the DS1811, or a supervisor IC connected to the RSTZ pin.

### RSTZ Pin

When not configured as  $\overline{\text{STRB}}$  output, the RSTZ pin is to be connected to  $V_{CC}$ , directly or through a resistor. A local  $V_{CC}$  supply can be created by taking energy from the 1-Wire line, as shown in Figure 21.

## PACKAGE INFORMATION

For the latest package outline information and land patterns, go to [www.maxim-ic.com/packages](http://www.maxim-ic.com/packages). Note that a "+", "#", or "-" in the package code indicates RoHS status only. Package drawings may show a different suffix character, but the drawing pertains to the package regardless of RoHS status.

PACKAGE TYPE	PACKAGE CODE	OUTLINE NO.	LAND PATTERN NO.
16 SO (150 mils)	S16+5	<a href="#">21-0041</a>	<a href="#">90-0097</a>

## Revision History

REVISION DATE	DESCRIPTION	PAGES CHANGED
051403	Initial release	—
122203	Corrected the wiring in Figure 18: in 4-bit mode, the display uses D4 to D7.	28
061604	Deleted empty page at the end	37
12/10	Updated the Ordering Information for lead(Pb)-free; updated soldering temperature in the Absolute Maximum Ratings. Applied EC table note 14 to $t_{WOL}$ . Deleted $\varepsilon$ from the $t_{WIL}$ spec in the EC table. $V_{TL}/V_{TH}$ clarification: Added to EC table note 5 the text ", which in parasitic power mode, is a function of ..." Added to EC table notes 14 and 15 the reference to Figure 14 and the text "The actual maximum duration..." Added $\varepsilon$ to the write zero time slot graphic in Figure 14. Added the Applications Information section; added the Package Information section	1, 2, 3, 4, 25, 38
3/15	Updated <i>Benefits and Features</i> section	1

Maxim Integrated cannot assume responsibility for use of any circuitry other than circuitry entirely embodied in a Maxim Integrated product. No circuit patent licenses are implied. Maxim Integrated reserves the right to change the circuitry and specifications without notice at any time. The parametric values (min and max limits) shown in the Electrical Characteristics table are guaranteed. Other parametric values quoted in this data sheet are provided for guidance.

**Maxim Integrated, 160 Rio Robles, San Jose, CA 95134 1-408-601-1000**

©2015 Maxim Integrated Products, Inc. The Maxim logo and Maxim Integrated are trademarks of Maxim Integrated Products, Inc.

## Looking for pricing, stock, or lifecycle information?

Click below to explore more details on WIN SOURCE:

 [View DS2408S+T&R on WIN SOURCE](#)

 [Maxim Integrated](#) Information

## Optimize Your Supply Chain with WIN SOURCE Solutions

-  Global Sourcing Solution
-  Obsolete Management
-  Cost Control Management
-  Shortage Management
-  Alternative Solution
-  Excess Inventory Management