



**THE DATASHEET OF
ELLXT971ABE.A4-870479**





Cortina Systems® LXT971A Single-Port 10/100 Mbps PHY Transceiver

Datasheet

The Cortina Systems® LXT971A Single-Port 10/100 Mbps PHY Transceiver (LXT971A PHY) directly supports both 100BASE-TX and 10BASE-T applications. It provides a Media Independent Interface (MII) for easy attachment to 10/100 Media Access Controllers (MACs). The LXT971A PHY is IEEE compliant, and provides a Low Voltage Positive Emitter Coupled Logic (LVPECL) interface for use with 100BASE-FX fiber networks. The LXT971A PHY supports full-duplex operation at 10 Mbps and 100 Mbps. Operating conditions for the LXT971A PHY can be set using auto-negotiation, parallel detection, or manual control. The LXT971A PHY is fabricated with an advanced CMOS process and requires only a single 2.5/3.3 V power supply. (This Datasheet also supports the LXT971 PHY.)

Applications

- Combination 10BASE-T/100BASE-TX or 100BASE-FX Network Interface Cards (NICs)
- Network printers
- 10/100 Mbps PCMCIA cards
- Cable Modems and Set-Top Boxes

Product Features

- 3.3 V Operation
 - Low power consumption (300 mW typical)
 - Low-power "Sleep" mode
 - 10BASE-T and 100BASE-TX using a single RJ-45 connection
 - IEEE 802.3-compliant 10BASE-T or 100BASE-TX ports with integrated filters
 - Auto-negotiation and parallel detection
 - MII interface with extended register capability
 - Robust baseline wander correction
 - Carrier Sense Multiple Access / Collision Detection (CSMA/CD) or full-duplex operation
 - JTAG boundary scan
 - MDIO serial port or hardware pin configurable
 - 100BASE-FX fiber-optic capable
 - Integrated, programmable LED drivers
 - 64-ball Plastic Ball Grid Array (PBGA) or 64-pin Quad Flat Package (LQFP)
 - LXT971ABC - Commercial (0° to 70 °C amb.)
 - LXT971ABE - Extended (-40° to 85 °C amb.)
 - LXT971ALC - Commercial (0° to 70 °C amb.)
 - LXT971ALE - Extended (-40° to 85 °C amb.)
 - LXT972ALC - Commercial (0° to 70 °C amb.)
-

**INFORMATION IN THIS DOCUMENT IS PROVIDED IN CONNECTION WITH CORTINA SYSTEMS® PRODUCTS.
NO LICENSE, EXPRESS OR IMPLIED, BY ESTOPPEL OR OTHERWISE, TO ANY INTELLECTUAL PROPERTY RIGHTS IS
GRANTED BY THIS DOCUMENT.**

**EXCEPT AS PROVIDED IN CORTINA'S TERMS AND CONDITIONS OF SALE OF SUCH PRODUCTS, CORTINA ASSUMES
NO LIABILITY WHATSOEVER, AND CORTINA DISCLAIMS ANY EXPRESS OR IMPLIED WARRANTY RELATING TO THE
SALE AND/OR USE OF CORTINA PRODUCTS, INCLUDING LIABILITY OR WARRANTIES RELATING TO FITNESS FOR A
PARTICULAR PURPOSE, MERCHANTABILITY OR INFRINGEMENT OF ANY PATENT, COPYRIGHT OR OTHER
INTELLECTUAL PROPERTY RIGHT.**

Cortina products are not intended for use in medical, life saving, life sustaining, critical control or safety systems, or in nuclear facility applications.

Cortina Systems® and the Cortina Systems logo are the trademarks or registered trademarks of Cortina Systems, Inc. and its subsidiaries in the U.S. and other countries. Other names and brands may be claimed as the property of others.

Copyright © 2007 Cortina Systems, Inc. All rights reserved.

Contents

1.0	Introduction to This Document	10
1.1	Document Overview	10
1.2	Related Documents	10
2.0	Block Diagram	11
3.0	Ball and Pin Assignments	12
4.0	Signal Descriptions	17
5.0	Functional Description.....	24
5.1	Device Overview.....	24
5.1.1	Comprehensive Functionality	24
5.1.2	Optimal Signal Processing Architecture.....	24
5.2	Network Media / Protocol Support.....	25
5.2.1	10/100 Network Interface.....	25
5.2.2	MII Data Interface	27
5.2.3	Configuration Management Interface	27
5.3	Operating Requirements.....	29
5.3.1	Power Requirements	29
5.3.2	Clock Requirements	30
5.4	Initialization	30
5.4.1	MDIO Control Mode and Hardware Control Mode.....	31
5.4.2	Reduced-Power Modes	32
5.4.3	Reset	33
5.4.4	Hardware Configuration Settings.....	33
5.5	Establishing Link.....	34
5.5.1	Auto-Negotiation	35
5.5.2	Parallel Detection.....	36
5.6	MII Operation	36
5.6.1	MII Clocks	37
5.6.2	Transmit Enable.....	39
5.6.3	Receive Data Valid	39
5.6.4	Carrier Sense.....	39
5.6.5	Error Signals	40
5.6.6	Collision	40
5.6.7	Loopback	40
5.7	100 Mbps Operation	42
5.7.1	100BASE-X Network Operations.....	42
5.7.2	Collision Indication.....	44
5.7.3	100BASE-X Protocol Sublayer Operations.....	45
5.8	10 Mbps Operation	49
5.8.1	10BASE-T Preamble Handling.....	49
5.8.2	10BASE-T Carrier Sense.....	49
5.8.3	10BASE-T Dribble Bits	49
5.8.4	10BASE-T Link Integrity Test	50
5.8.5	Link Failure	50
5.8.6	10BASE-T SQE (Heartbeat).....	50
5.8.7	10BASE-T Jabber.....	50

5.8.8	10BASE-T Polarity Correction	50
5.9	Monitoring Operations	50
5.9.1	Monitoring Auto-Negotiation	50
5.9.2	Monitoring Next Page Exchange	51
5.9.3	LED Functions	51
5.9.4	LED Pulse Stretching.....	52
5.10	Boundary Scan (JTAG 1149.1) Functions	52
5.10.1	Boundary Scan Interface	52
5.10.2	State Machine	52
5.10.3	Instruction Register	53
5.10.4	Boundary Scan Register.....	53
5.10.5	Device ID Register	53
6.0	Application Information	54
6.1	Magnetics Information	54
6.2	Typical Twisted-Pair Interface	54
6.3	Fiber Interface.....	57
7.0	Electrical Specifications	61
7.1	DC Electrical Parameters	61
7.2	AC Timing Diagrams and Parameters	65
8.0	Register Definitions - IEEE Base Registers	78
9.0	Register Definitions - Product-Specific Registers	86
10.0	Package Specifications.....	94

Figures

1	Block Diagram	11
2	64-Ball PBGA: Ball Assignments	13
3	64-Pin LQFP Package: Pins Assignments	14
4	Management Interface Read Frame Structure	28
5	Management Interface Write Frame Structure	28
6	MII Interrupt Logic	29
7	Initialization Sequence	31
8	Hardware Configuration Settings	34
9	Link Establishment Overview	35
10	Clocking for 10BASE-T	38
11	Clocking for 100BASE-X	38
12	Clocking for Link Down Clock Transition	39
13	Loopback Paths	41
14	100BASE-X Frame Format	42
15	100BASE-TX Data Path	43
16	100BASE-TX Reception with No Errors	43
17	100BASE-TX Reception with Invalid Symbol	44
18	100BASE-TX Transmission with No Errors	44
19	100BASE-TX Transmission with Collision	44
20	Protocol Sublayers	45
21	LED Pulse Stretching	52
22	Typical Twisted-Pair Interface - Switch	55
23	Typical Twisted-Pair Interface - NIC	56
24	Typical Media Independent Interface	57
25	Typical Interface - LXT971A PHY to 3.3 V Fiber PHY	58
26	Typical Interface LXT971A PHY to 5 V Fiber PHY	59
27	Typical Interface - LXT971A PHY to Triple PECL-to-PECL Logic Translator	60
28	100BASE-TX Receive Timing - 4B Mode	66
29	100BASE-TX Transmit Timing - 4B Mode	67
30	100BASE-FX Receive Timing	68
31	100BASE-FX Transmit Timing	69
32	10BASE-T Receive Timing	70
33	10BASE-T Receive Timing	70
34	10BASE-T Transmit Timing	72
35	10BASE-T Jabber and Unjabber Timing	73
36	10BASE-T SQE (Heartbeat) Timing	73
37	Auto-Negotiation and Fast Link Pulse Timing	74
38	Fast Link Pulse Timing	74
39	MDIO Input Timing	75
40	MDIO Output Timing	75
41	Power-Up Timing	76
42	RESET_L Pulse Width and Recovery Timing	76
43	PHY Identifier Bit Mapping	81
44	PBGA Package Specification	94
45	LQFP Package Specifications	95

Tables

1	Related Documents	10
2	PHY Signal Types	12
3	LQFP Numeric Pin List	14
4	PHY Signal Types	17
5	MII Data Interface Signal Descriptions	18
6	MII Controller Interface Signal Descriptions	19
7	Network Interface Signal Descriptions	20
8	Standard Bus and Interface Signal Descriptions	20
9	Configuration and LED Driver Signal Descriptions	20
10	Power, Ground, No-Connect Signal Descriptions	22
11	JTAG Test Signal Descriptions	22
12	Pin Types and Modes	23
13	Hardware Configuration Settings	33
14	Carrier Sense, Loopback, and Collision Conditions	40
15	4B/5B Coding	46
16	Valid JTAG Instructions	53
17	BSR Mode of Operation	53
18	Device ID Register	53
19	Magnetics Requirements	54
20	I/O Pin Comparison of NIC and Switch RJ-45 Setups	54
21	Absolute Maximum Ratings	61
22	Recommended Operating Conditions	61
23	Digital I/O Characteristics (Except for MII, XI/XO, and LED/CFG Pins)	62
24	Digital I/O Characteristics ¹ - MII Pins	62
25	I/O Characteristics - REFCLK/XI and XO Pins	63
26	I/O Characteristics - LED/CFG Pins	63
27	I/O Characteristics – SD/TP_L Pin	63
28	100BASE-TX PHY Characteristics	63
29	100BASE-FX PHY Characteristics	64
30	10BASE-T PHY Characteristics	64
31	10BASE-T Link Integrity Timing Characteristics	65
32	Thermal Characteristics	65
33	100BASE-TX Receive Timing Parameters - 4B Mode	66
34	100BASE-TX Transmit Timing Parameters - 4B Mode	67
35	100BASE-FX Receive Timing Parameters	68
36	100BASE-FX Transmit Timing Parameters	69
37	10BASE-T Receive Timing Parameters	71
38	10BASE-T Transmit Timing Parameters	72
39	10BASE-T Jabber and Unjabber Timing	73
40	PHY 10BASE-T SQE (Heartbeat) Timing	73
41	Auto-Negotiation and Fast Link Pulse Timing Parameters	74
42	MDIO Timing	75
43	Power-Up Timing	76
44	RESET_L Pulse Width and Recovery Timing	77
45	Register Set for IEEE Base Registers	78
46	Control Register - Address 0, Hex 0	79
47	MII Status Register #1 - Address 1, Hex 1	80
48	PHY Identification Register 1 - Address 2, Hex 2	81

49	PHY Identification Register 2 - Address 3, Hex 3.....	81
50	Auto-Negotiation Advertisement Register - Address 4, Hex 4.....	82
51	Auto-Negotiation Link Partner Base Page Ability Register - Address 5, Hex 5.....	83
52	Auto-Negotiation Expansion - Address 6, Hex 6.....	84
53	Auto-Negotiation Next Page Transmit Register - Address 7, Hex 7.....	84
54	Auto-Negotiation Link Partner Next Page Receive Register - Address 8, Hex 8.....	85
55	Register Set for Product-Specific Registers.....	86
56	Configuration Register - Address 16, Hex 10.....	86
57	Status Register #2 - Address 17, Hex 11.....	87
58	Interrupt Enable Register - Address 18, Hex 12.....	89
59	Status Change Register - Address 19, Hex 13.....	89
60	LED Configuration Register - Address 20, Hex 14.....	91
61	Digital Configuration Register - Address 26, Hex 1A.....	92
62	Transmit Control Register - Address 30, Hex 1E.....	93

Revision History

<p style="text-align: center;">Revision 5.2 Revision Date: 13 September 2007</p>
<ul style="list-style-type: none">Removed outdated Figure 4: 64-Pin Pb-Free LQFP Package: Pins AssignmentsRemoved the ordering information. This information is now available from www.cortina-systems.com.
<p style="text-align: center;">Revision 5.1 Revision Date: 23 July 2007</p>
Added Section 10.0, Package Specifications back into Datasheet.
<p style="text-align: center;">Revision 5.0 Revision Date: 2 July 2007</p>
First release of this document from Cortina Systems, Inc.
<p style="text-align: center;">Revision 004 Revision Date: 01 January 2007</p>
Internal release. No changes.
<p style="text-align: center;">Revision 003 Revision Date: 25 October 2005</p>
Front page text changed.
Changed "PECL Interface" to "LVPECL Interface" in Figure 21 "Protocol Sublayers" .
Replaced text under Section 5.7.3.4, "Fiber PMD Sublayer" .
Modified first paragraph under Section 6.3, "The Fiber Interface" .
Modified text and added a new bullet in first and second set of bullets under Section 6.3, "The Fiber Interface" .
Replaced Figure 27 "Recommended LXT971A-to-3.3 V Fiber PHY Interface Circuitry" .
Replaced Figure 28 "Recommended LXT971A-to-5 V Fiber PHY Interface Circuitry" .
Added Section 10.1, Top Label Markings .
Modified Section 14.0, Product Ordering Information : added RoHS information to Table 140, Product Ordering Information and changed Figure 123, Order Matrix for Cortina Systems® LXT971A Transceiver - Sample .
<p style="text-align: center;">Revision 002 Revision Date: 06 August 2002</p>
Globally replaced "pseudo-PECL" with Low-Voltage PECL", except when identified with 5 V.
Front Page: Changed "pseudo-ECL (PECL)" to "Low Voltage PECL (LVPECL). Added "JTAG Boundary Scan" to Product Features on front page.
Modified Figure 2 "LXT971A 64-Ball PBGA Assignments" (replaced TEST1 and TEST0 with GND).
Modified Figure 3 "LXT971A 64-Pin LQFP Assignments" (replaced TEST1 and TEST0 with GND).
Modified Table 1 "LQFP Numeric Pin List" (replaced TEST1 and TEST0 with GND).
Added note under Section 2.0, "Signal Descriptions" : "Intel recommends that all inputs and multi-function pins be tied to the inactive states and all outputs be left floating, if unused."

Revision 002 Revision Date: 06 August 2002
Modified SD/TP description in Table 3 "LXT971A Network Interface Signal Descriptions" . Added Table note 2.
Modified Table 4 "LXT971A Miscellaneous Signal Descriptions" .
Modified Table 5 "LXT971A Power Supply Signal Descriptions" .
Added Table 8 "LXT971A Pin Types and Modes" .
Replaced second paragraph under Section 3.2.1.2, "Fiber Interface" .
Added Section 3.2.2.1, "Increased MII Drive Strength" .
Changed "Far-End Fault" title to '100BASE-FX Far-End Fault'. Modified first sentence under this heading.
Modified Figure 8 "Hardware Configuration Settings" .
Added paragraph after bullets under Section 3.6.7.2, "Test Loopback" .
Modified text under Section 3.7.3.4, "Fiber PMD Sublayer" .
Modified Table 13 "Supported JTAG Instructions" .
Modified Table 14 "Device ID Register" .
Added a new Section 4.3, "The Fiber Interface" .
Replaced Figure 25 "Recommended LXT971A-to-3.3 V Fiber PHY Interface Circuitry" .
Added Figure 26 "Recommended LXT971A-to-5 V Fiber PHY Interface Circuitry" .
Added Figure 27 "ON Semiconductor Triple PECL-to-LVPECL Logic Translator" .
Modified Table 17 "Absolute Maximum Ratings" .
Modified Table 18 "Operating Conditions" : Added Typ values to Vcc current.
Modified Table 20 "Digital I/O Characteristics - MII Pins" .
Modified Table 22 "I/O Characteristics - LED/CFG Pins" .
Added Table 23 "I/O Characteristics – SD/TP Pin" .
Added Table 28 "LXT971A Thermal Characteristics" .
Modified Table 33 "10BASE-T Receive Timing Parameters" .
Modified Table 42 "register bit Map" . (Added Table 26 information).
Added Table 57 "Digital Configuration Register (Address 26)" .
Modified Table 58 "Transmit Control Register (Address 30)" .
Added Section 8.0, "Product Ordering Information" .

Revision 001 Revision Date: 01 January 2001
Clock Requirements: Modified language under Clock Requirements heading.
Table 21 I/O Characteristics REFCLK : Changed values for Input Clock Duty Cycle under Min from 40 to 35 and under Max from 60 to 65.

1.0 Introduction to This Document

This document includes information on the Cortina Systems® LXT971A Single-Port 10/100 Mbps PHY Transceiver (LXT971A PHY).

1.1 Document Overview

This document includes the following subjects:

2.0, Block Diagram, on page 11

3.0, Ball and Pin Assignments, on page 12

4.0, Signal Descriptions, on page 17

5.0, Functional Description, on page 24

6.0, Application Information, on page 54

7.0, Electrical Specifications, on page 61

8.0, Register Definitions - IEEE Base Registers, on page 78

9.0, Register Definitions - Product-Specific Registers, on page 86

1.2 Related Documents

Table 1 Related Documents

Document Title	Document Number
Fiber Optic PHYs Connecting a PECL Interface Application Note	249015
Cortina Systems® 100BASE-FX Fiber Optic PHYs - Connecting a PECL/LVPECL Interface Application Note	250781
Cortina Systems® LXT971A, LXT972A, LXT972M Single-Port 10/100 Mbps PHY Specification Update	249354
Cortina Systems® LXT971A, LXT972A, and LXT972M 3.3 V PHY Design and Layout Guide - Application Note	249016
Magnetic Manufacturers for Networking Product Applications - Application Note	248991

2.0 Block Diagram

Figure 1 Block Diagram

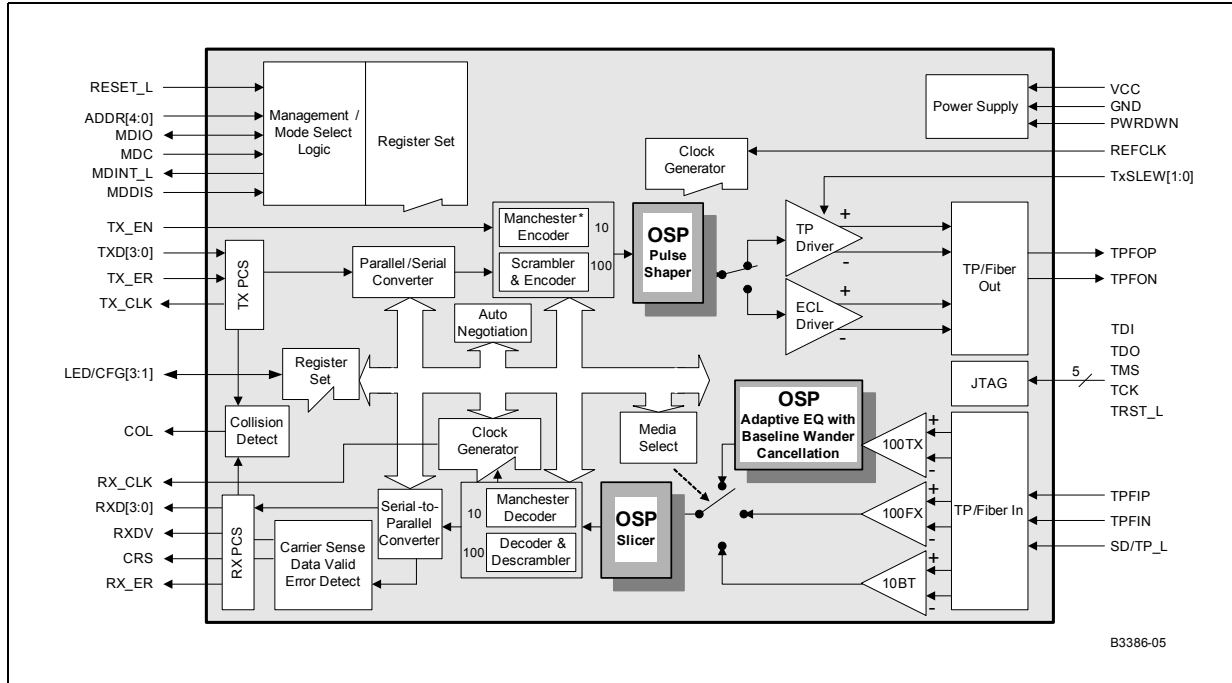

3.0 Ball and Pin Assignments

See the following diagrams for signal placement:

- [Figure 2, 64-Ball PBGA: Ball Assignments, on page 13](#)
- [Figure 3, 64-Pin LQFP Package: Pins Assignments, on page 14](#)

See the following tables for signal lists:

- [Table 3, LQFP Numeric Pin List, on page 14](#)

Note: [Table 2](#) list the signal type abbreviations used in the signal tables.

Table 2 **PHY Signal Types**

Abbreviation	Definition
AI	Analog Input
AO	Analog Output
I	Input
I/O	Input/Output
O	Output
OD	Open Drain

Figure 2 64-Ball PBGA: Ball Assignments

	1	2	3	4	5	6	7	8	
A	MDINT_L	CRS	TXD3	TXD0	RX_ER	VCCD	RX_DV	RXD0	A
B	REF_CLK/XI	COL	TXD2	TX_EN	TX_ER	RX_CLK	NC	RXD1	B
C	XO	RESET_L	GND	TXD1	TX_CLK	GND	NC	RXD2	C
D	Tx_SLEW0	Tx_SLEW1	MDDIS	GND	VCCIO	RXD3	NC	MDIO	D
E	ADDR0	ADDR1	GND	GND	VCCIO	LED_CFG1	MDC	PWR_DWN	E
F	ADDR3	ADDR2	GND	GND	TDI	TMS	LED_CFG2	LED_CFG3	F
G	ADDR4	SD/TP_L	VCCA	VCCA	TDO	TCK	GND	GND	G
H	RBIAS	TPFOP	TPFON	TPFIP	TPFIN	TRST_L	SLEEP	PAUSE	H
	1	2	3	4	5	6	7	8	

B3477-01

Figure 3 64-Pin LQFP Package: Pins Assignments

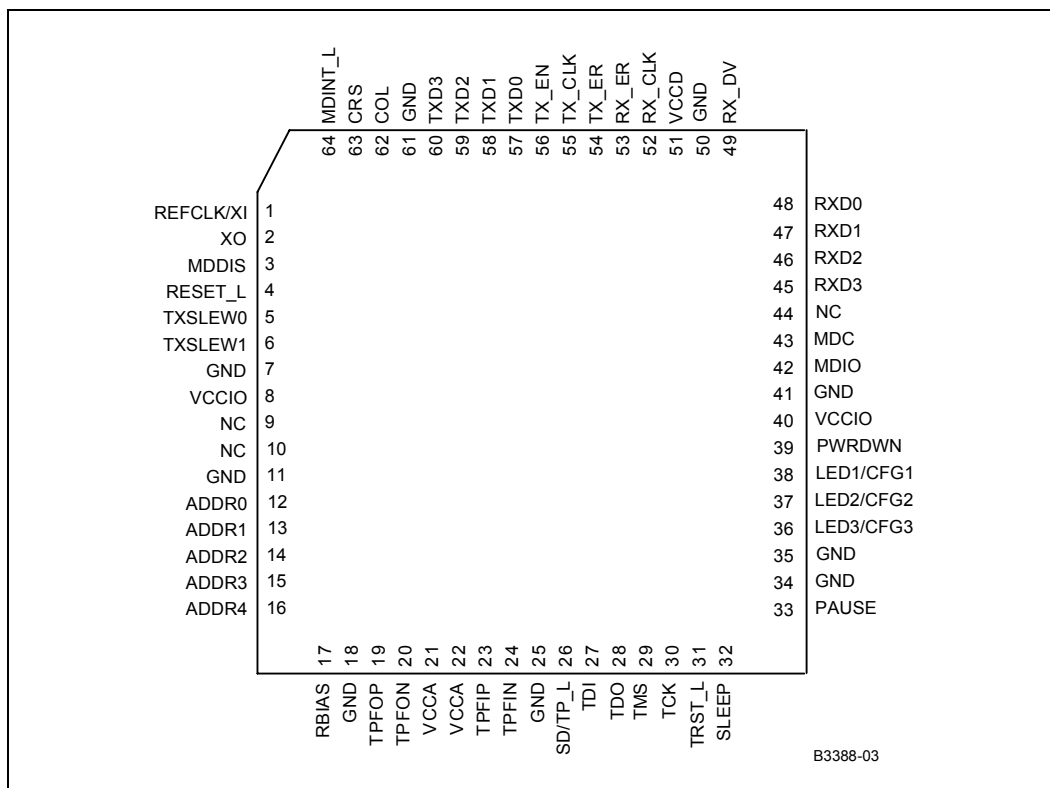

Table 3 LQFP Numeric Pin List (Sheet 1 of 3)

Pin	Symbol	Type
1	REFCLK/XI	I
2	XO	O
3	MDDIS	I
4	RESET_L	I
5	TxSLEW0	I
6	TxSLEW1	I
7	GND	-
8	VCCIO	-
9	NC	-
10	NC	-
11	GND	-
12	ADDR0	I
13	ADDR1	I
14	ADDR2	I
15	ADDR3	I

Table 3 LQFP Numeric Pin List (Sheet 2 of 3)

Pin	Symbol	Type
16	ADDR4	I
17	RBIAS	AI
18	GND	–
19	TPFOP	O
20	TPFON	O
21	VCCA	–
22	VCCA	–
23	TPFIP	I
24	TPFIN	I
25	GND	–
26	SD/TP_L	I
27	TDI	I
28	TDO	O
29	TMS	I
30	TCK	I
31	TRST_L	I
32	SLEEP	I
33	PAUSE	I
34	GND	–
35	GND	–
36	LED/CFG3	I/O
37	LED/CFG2	I/O
38	LED/CFG1	I/O
39	PWRDWN	I
40	VCCIO	–
41	GND	–
42	MDIO	I/O
43	MDC	I
44	NC	–
45	RXD3	O
46	RXD2	O
47	RXD1	O
48	RXD0	O
49	RX_DV	O
50	GND	–
51	VCCD	–
52	RX_CLK	O
53	RX_ER	O

Table 3 LQFP Numeric Pin List (Sheet 3 of 3)

Pin	Symbol	Type
54	TX_ER	I
55	TX_CLK	O
56	TX_EN	I
57	TXD0	I
58	TXD1	I
59	TXD2	I
60	TXD3	I
61	GND	–
62	COL	O
63	CRS	O
64	MDINT_L	OD

4.0 Signal Descriptions

Cortina recommends the following configurations for unused pins:

- **Unused inputs.** Configure all unused inputs and unused multi-function pins for inactive states.
- **Unused outputs.** Leave all unused outputs floating.
- **No connects.** Do not use pins designated as NC (no connect), and do not terminate them.

Note: Table 4 list the signal type abbreviations used in the signal tables.

Table 4 PHY Signal Types

Abbreviation	Definition
AI	Analog Input
AO	Analog Output
I	Input
I/O	Input/Output
O	Output
OD	Open Drain

Tables in this section include the following:

- [Table 5, MII Data Interface Signal Descriptions, on page 18](#)
- [Table 6, MII Controller Interface Signal Descriptions, on page 19](#)
- [Table 7, Network Interface Signal Descriptions, on page 20](#)
- [Table 8, Standard Bus and Interface Signal Descriptions, on page 20](#)
- [Table 9, Configuration and LED Driver Signal Descriptions](#)
- [Table 10, Power, Ground, No-Connect Signal Descriptions, on page 22](#)
- [Table 11, JTAG Test Signal Descriptions, on page 22](#)
- [Table 12, Pin Types and Modes, on page 23](#)

Table 5 MII Data Interface Signal Descriptions

PBGA Pin#	LQFP Pin#	Symbol	Type	Signal Description
A3 B3 C4 A4	60 59 58 57	TXD3 TXD2 TXD1 TXD0	I	Transmit Data. TXD is a group of parallel data signals that are driven by the MAC. TXD[3:0] transition synchronously with respect to TX_CLK. TXD[0] is the least-significant bit.
B4	56	TX_EN	I	Transmit Enable. The MAC asserts this signal when it drives valid data on TXD. This signal must be synchronized to TX_CLK.
C5	55	TX_CLK	O	Transmit Clock. TX_CLK is sourced by the PHY in both 10 and 100 Mbps operations. 2.5 MHz for 10 Mbps operation 25 MHz for 100 Mbps operation.
D6 C8 B8 A8	45 46 47 48	RXD3 RXD2 RXD1 RXD0	O	Receive Data. RXD is a group of parallel signals that transition synchronously with respect to RX_CLK. RXD[0] is the least-significant bit.
A7	49	RX_DV	O	Receive Data Valid. The PHY asserts this signal when it drives valid data on RXD. This output is synchronous to RX_CLK.
A5	53	RX_ER	O	Receive Error. Signals a receive error condition has occurred. This output is synchronous to RX_CLK.
B5	54	TX_ER	I	Transmit Error. Signals a transmit error condition. This signal must be synchronized to TX_CLK.
B6	52	RX_CLK	O	Receive Clock. 25 MHz for 100 Mbps operation. 2.5 MHz for 10 Mbps operation. For details, see Section 5.3.2, Clock Requirements , on page 30 in the Functional Description section.
B2	62	COL	O	Collision Detected. The PHY asserts this output when a collision is detected. This output remains High for the duration of the collision. This signal is asynchronous and is inactive during full- duplex operation.
A2	63	CRS	O	Carrier Sense. During half-duplex operation (register bit 0.8 = 0), the PHY asserts this output when either transmitting or receiving data packets. During full-duplex operation (register bit 0.8 = 1), CRS is asserted only during receive. CRS assertion is asynchronous with respect to RX_CLK. CRS is de-asserted on loss of carrier, synchronous to RX_CLK.

Table 6 MII Controller Interface Signal Descriptions

PBGA Pin#	LQFP Pin#	Symbol	Type	Signal Description
D3	3	MDDIS	I	<p>Management Data Disable. When MDDIS is High, the MDIO is disabled from read and write operations. When MDDIS is Low at power-up or reset, the Hardware Control Interface pins control only the initial or “default” values of their respective register bits. After the power-up/reset cycle is complete, bit control reverts to the MDIO serial channel.</p>
E7	43	MDC	I	<p>Management Data Clock. Clock for the MDIO serial data channel. Maximum frequency is 8 MHz.</p>
D8	42	MDIO	I/O	<p>Management Data Input/Output. Bidirectional serial data channel for PHY/STA communication.</p>
A1	64	MDINT_L	OD	<p>Management Data Interrupt. When register bit 18.1 = 1, an active Low output on this pin indicates status change. Interrupt is cleared by reading Register 19.</p>

Table 7 Network Interface Signal Descriptions

PBGA Pin#	LQFP Pin#	Symbol	Type	Signal Description
H2 H3	19 20	TPFOP TPFON	O	Twisted-Pair/Fiber Outputs, Positive and Negative. During 100BASE-TX or 10BASE-T operation, TPFOP/N pins drive IEEE 802.3 compliant pulses onto the line. During 100BASE-FX operation, TPFOP/N pins produce differential LVPECL outputs for fiber PHYs.
H4 H5	23 24	TPFIP TPFIN	I	Twisted-Pair/Fiber Inputs, Positive and Negative. During 100BASE-TX or 10BASE-T operation, TPFIP/N pins receive differential 100BASE-TX or 10BASE-T signals from the line. During 100BASE-FX operation, TPFIP/N pins receive differential LVPECL inputs from fiber PHYs.
G2	26	SD/TP_L	I	Signal Detect / Twisted Pair. SD/TP_L acts as a dual-function input, depending on the LXT971A PHY mode. Normal, Reset, and Power-Up Operations. “Normal” operation is operation other than reset or power-up. In either reset or power-up, SD/TP_L is used to select one of the two following media modes. <ul style="list-style-type: none"> Twisted-pair mode - Connect SD/TP_L Low (register bit 16.0 = 0). Fiber mode - Connect SD/TP_L High (register bit 16.0 = 1). Twisted-Pair Mode. For normal operation that uses the twisted-pair mode, connect SD/TP_L to ground. Fiber Mode. For normal operation that uses the fiber mode, SD/TP_L acts as the SD input from the fiber PHY.

Table 8 Standard Bus and Interface Signal Descriptions

PBGA Pin#	LQFP Pin#	Symbol	Type	Signal Description
G1 F1 F2 E2 E1	16 15 14 13 12	ADDR0	I I I I I	Address. Sets device address.

Table 9 Configuration and LED Driver Signal Descriptions (Sheet 1 of 2)

PBGA Pin#	LQFP Pin#	Symbol	Type	Signal Description
Note: Implement 10 kΩ pull-up/pull-down resistors if LEDs are not used in the design.				

Table 9 Configuration and LED Driver Signal Descriptions (Sheet 2 of 2)

PBGA Pin#	LQFP Pin#	Symbol	Type	Signal Description															
D1 D2	5 6	TxSLEW0 TxSLEW1	I	<p>Tx Output Slew Controls 0 and 1. These pins select the TX output slew rate (rise and fall time) as follows:</p> <table border="1"> <thead> <tr> <th>TxSLEW1</th> <th>TxSLEW0</th> <th>Slew Rate (Rise and Fall Time)</th> </tr> </thead> <tbody> <tr> <td>0</td> <td>0</td> <td>3.0 ns</td> </tr> <tr> <td>0</td> <td>1</td> <td>3.4 ns</td> </tr> <tr> <td>1</td> <td>0</td> <td>3.9 ns</td> </tr> <tr> <td>1</td> <td>1</td> <td>4.4 ns</td> </tr> </tbody> </table>	TxSLEW1	TxSLEW0	Slew Rate (Rise and Fall Time)	0	0	3.0 ns	0	1	3.4 ns	1	0	3.9 ns	1	1	4.4 ns
TxSLEW1	TxSLEW0	Slew Rate (Rise and Fall Time)																	
0	0	3.0 ns																	
0	1	3.4 ns																	
1	0	3.9 ns																	
1	1	4.4 ns																	
C2	4	$\overline{\text{RESET_L}}$	I	<p>Reset. This active Low input is ORed with the control register Reset bit (register bit 0.15). The PHY reset cycle is extended to 258 μs (nominal) after reset is de-asserted.</p>															
H1	17	RBIAS	AI	<p>Reference Current Bias. This pin provides bias current for the internal circuitry. Must be tied to ground through a 22.1 kΩ, 1% resistor.</p>															
H8	33	PAUSE	I	<p>Pause. When set High, the PHY advertises Pause capabilities during auto-negotiation.</p>															
H7	32	SLEEP	I	<p>Sleep. When set High, this pin enables the PHY to go into a low-power sleep mode. The value of this pin can be overridden by register bit 16.6 when in managed mode.</p>															
E8	39	PWRDWN	I	<p>Power Down. When set High, this pin puts the PHY in a power-down mode.</p>															
B1 C1	1 2	REFCLK/XI XO	I and O	<p>Reference Clock Input / Crystal Input and Crystal Output. A 25 MHz crystal oscillator circuit can be connected across XI and XO. A clock can also be used at XI. For clock requirements, see Section 5.3.2, Clock Requirements, on page 30 in the Functional Description section.</p>															
E6 F7 F8	38 37 36	LED/CFG1 LED/CFG2 LED/CFG3	I/O	<p>LED Drivers 1-3. These pins drive LED indicators. Each LED can display one of several available status conditions as selected by the LED Configuration Register. (For details, see Table 60, LED Configuration Register - Address 20, Hex 14, on page 91.)</p> <p>Configuration Inputs 1-3. These pins also provide initial configuration settings. (For details, see Table 13, Hardware Configuration Settings, on page 33.)</p>															

Table 10 Power, Ground, No-Connect Signal Descriptions

PBGA Pin#	LQFP Pin#	Symbol	Type	Signal Description
A6	51	VCCD	–	Digital Power. Requires a 3.3 V power supply.
D4, E3, E4, F3, F4, C6, C3, G7, G8	7, 11, 18, 25, 34, 35, 41, 50, 61	GND	–	Ground.
E5, D5	8, 40	VCCIO	–	MII Power. Requires either a 3.3 V or a 2.5 V supply. Must be supplied from the same source used to power the MAC on the other side of the MII.
G3, G4	21, 22	VCCA	–	Analog Power. Requires a 3.3 V power supply.
B7, C7 D7	9, 10, 44	NC	-	No Connection. These pins are not used and should not be terminated.

Table 11 JTAG Test Signal Descriptions

PBGA Pin#	LQFP Pin#	Symbol	Type	Signal Description
Note: These pins do not need to be terminated if a JTAG port is not used.				
F5	27	TDI	I	Test Data Input. Test data sampled with respect to the rising edge of TCK.
G5	28	TDO	O	Test Data Output. Test data driven with respect to the falling edge of TCK.
F6	29	TMS	I	Test Mode Select.
G6	30	TCK	I	Test Clock. Clock input for boundary scan.
H6	31	TRST_L	I	Test Reset.

Table 12 Pin Types and Modes

Modes	RXD3:0	RX_DV	Tx/Rx CLKS Output	RX_ER Output	COL Output	CRS Output	TXD3:0 Input	TX_EN Input	TX_ER Input
HWReset	DL	DL	DH	DL	DL	DL	ID	ID	ID
SFTPWRDN	DL	DL	Active	DL	DL	DL	ID	ID	ID
HWPWRDN	HZ	HZ	HZ	HZ	HZ	HZ	HZ	HZ	HZ
ISOLATE	HZ with ID	HZ with ID	HZ with ID	HZ with ID	HZ with ID	HZ with ID	ID	ID	ID
SLEEP	DL	DL	DL	DL	DL	DL	ID	ID	ID
<ul style="list-style-type: none"> • DH = Driven High (Logic 1) • DL = Driven Low (Logic 0) • HZ = High Impedance • ID = Internal Pull-Down (Weak) 									

5.0 Functional Description

This chapter has the following sections:

- Section 5.1, *Device Overview*, on page 24
- Section 5.2, *Network Media / Protocol Support*, on page 25
- Section 5.3, *Operating Requirements*, on page 29
- Section 5.4, *Initialization*, on page 30
- Section 5.5, *Establishing Link*, on page 34
- Section 5.6, *MII Operation*, on page 36
- Section 5.7, *100 Mbps Operation*, on page 42
- Section 5.8, *10 Mbps Operation*, on page 49
- Section 5.9, *Monitoring Operations*, on page 50
- Section 5.10, *Boundary Scan (JTAG 1149.1) Functions*, on page 52

5.1 Device Overview

The LXT971A PHY is a single-port Fast Ethernet 10/100 PHY that supports 10 Mbps and 100 Mbps networks. It complies with applicable requirements of IEEE 802.3. It directly drives either a 100BASE-TX line or a 10BASE-T line.

Note: The LXT971A PHY also supports 100BASE-FX operation through an LVPECL interface.

5.1.1 Comprehensive Functionality

The LXT971A PHY provides a standard Media Independent Interface (MII) for 10/100 MACs. The LXT971A PHY performs all functions of the Physical Coding Sublayer (PCS) and Physical Media Attachment (PMA) sublayer as defined in the IEEE 802.3 100BASE-X standard. It also performs all functions of the Physical Media Dependent (PMD) sublayer for 100BASE-TX connections.

The LXT971A PHY reads its configuration pins on power-up to check for forced operation settings.

If the LXT971A PHY is not set for forced operation, it uses auto-negotiation/parallel detection to automatically determine line operating conditions. If the PHY device on the other side of the link supports auto-negotiation, the LXT971A PHY auto-negotiates with it using Fast Link Pulse (FLP) Bursts. If the PHY partner does not support auto-negotiation, the LXT971A PHY automatically detects the presence of either link pulses (10 Mbps PHY) or Idle symbols (100 Mbps PHY) and sets its operating conditions accordingly.

The LXT971A PHY provides half-duplex and full-duplex operation at 100 Mbps and 10 Mbps.

5.1.2 Optimal Signal Processing Architecture

The LXT971A PHY incorporates high-efficiency Optimal Signal Processing (OSP) design techniques, which combine optimal properties of digital and analog signal processing.

The receiver utilizes decision feedback equalization to increase noise and cross-talk immunity by as much as 3 dB over an ideal all-analog equalizer. Using OSP mixed-signal processing techniques in the receive equalizer avoids the quantization noise and

calculation truncation errors found in traditional DSP-based receivers (typically complex DSP engines with A/D converters). This results in improved receiver noise and cross-talk performance.

The OSP signal processing scheme also requires substantially less computational logic than traditional DSP-based designs. This lowers power consumption and also reduces the logic switching noise generated by DSP engines. This logic switching noise can be a considerable source of EMI generated on the device's power supplies.

The OSP-based LXT971A PHY provides improved data recovery, EMI performance, and low power consumption.

5.2 Network Media / Protocol Support

This section includes the following:

- [Section 5.2.1, 10/100 Network Interface](#)
- [Section 5.2.2, MII Data Interface](#)
- [Section 5.2.3, Configuration Management Interface](#)

The LXT971A PHY supports both 10BASE-T and 100BASE-TX Ethernet over twisted-pair or 100 Mbps Ethernet over fiber media (100BASE-FX).

5.2.1 10/100 Network Interface

The network interface port consists of five external pins (two differential signal pairs and a signal detect pin). The I/O pins are shared between twisted-pair (TP) and fiber. For specific pin assignments, see [Section 4.0, Signal Descriptions, on page 17](#).

The LXT971A PHY output drivers can generate one of the following outputs:

- 100BASE-TX
- 10BASE-T
- 100BASE-FX

When not transmitting data, the LXT971A PHY generates IEEE 802.3-compliant link pulses or idle code. Depending on the mode selected, input signals are decoded as one of the following:

- 100BASE-TX
- 10BASE-T
- 100BASE-FX

Auto-negotiation/parallel detection or manual control is used to determine the speed of this interface.

5.2.1.1 Twisted-Pair Interface

The LXT971A PHY supports either 100BASE-TX or 10BASE-T connections over 100 Ω , Category 5, Unshielded Twisted Pair (UTP) cable. When operating at 100 Mbps, the LXT971A PHY continuously transmits and receives MLT3 symbols. When not transmitting data, the LXT971A PHY generates "IDLE" symbols.

During 10 Mbps operation, Xilinx* Manchester-encoded data is exchanged. When no data is being exchanged, the line is left in an idle state. Link pulses are transmitted periodically to keep the link up.

Only a transformer, RJ-45 connector, load resistor and bypass capacitors are required to complete this interface. On the transmit side, the LXT971A PHY has an active internal termination and does not require external termination resistors. Cortina's waveshaping technology shapes the outgoing signal to help reduce the need for external EMI filters. Four slew rate settings allow the designer to match the output waveform to the magnetic characteristics. On the receive side, the internal impedance is high enough that it has no practical effect on the external termination circuit. (For the slew rate settings, see [Table 62, Transmit Control Register - Address 30, Hex 1E, on page 93.](#))

5.2.1.2 Fiber Interface

The LXT971A PHY fiber port is designed to interface with common industry-standard fiber modules. It incorporates an LVPECL interface that complies with the ANSI X3.166 standard for seamless integration.

Fiber mode is selected through register bit 16.0 by the following two methods:

1. Drive the SD input to a value greater than 600 mV during power-up and reset states (all LVPECL signaling levels from a fiber PHY are acceptable).
2. Configure register bit 16.0 = 1 through the MDIO interface.

5.2.1.3 Remote Fault Detection and Reporting

The LXT971A PHY supports two remote fault detection and reporting mechanisms.

- "Remote Fault" refers to a MAC-to-MAC communication function that is transparent to PHY layer devices. It is used only during auto-negotiation, and is applicable only to twisted-pair links.
- "Far-End Fault" is an optional PMA-layer function that may be embedded within PHY devices.

Remote Fault Detection. register bit 4.13 in the Auto-Negotiation Advertisement Register is reserved for Remote Fault indications. It is typically used when re-starting the auto-negotiation sequence to indicate to the link partner that the link is down because the advertising device detected a local fault.

When the LXT971A PHY receives a Remote Fault indication from its partner during auto-negotiation, the following occurs:

- register bit 5.13 in the Link Partner Base Page Ability Register is set.
- Remote Fault register bit 1.4 in the MII Status Register is set to pass this information to the local controller.

100BASE-FX Far-End Fault Indication. The LXT971A PHY independently detects signal faults from the local fiber PHYs through the SD/TP_L pin. The LXT971A PHY also uses register bit 1.4 to report Remote Fault indications received from its link partner. The LXT971A PHY ORs both fault conditions to set bit 1.4 to '1'. register bit 1.4 is set once and clears to '0' when it is read. In fiber operations, the far-end fault detection process requires idles to establish link. Link does not establish if a far-end fault pattern is the initial signal detected.

Either fault condition causes the LXT971A PHY to drop the link unless Forced Link Pass is selected by setting register bit 16.14 to '1'. A 'link is down' condition is then reported with interrupts and status bits.

In response to locally detected signal faults (that is, the SD/TP_L pin is activated by the local fiber PHY), the affected port can transmit the far-end fault code if the fault code transmission is enabled by register bit 16.2.

- When register bit 16.2 = 0, the LXT971A PHY does not transmit far end fault code. It continues to transmit idle code and may or may not drop link depending on the setting for register bit 16.14.
- When register bit 16.2 = 1, transmission of the far end fault code is enabled. The LXT971A PHY transmits far end fault code if fault conditions are detected by the SD/TP_L pin.

The occurrence of a Far End Fault causes all transmission of data from the Reconciliation Sublayer to stop and the Far End fault code to begin. The Far End Fault code consists of 84 ones followed by a single zero. (This pattern must be repeated three times.)

If the LXT971A PHY detects a signal fault condition, it can transmit the Far-End Fault Indication (FEFI) over the fiber link. The FEFI consists of 84 consecutive ones followed by a single zero. This pattern must be repeated at least three times. The LXT971A PHY transmits the far-end fault code a minimum of three times if all the following conditions are true:

- Fiber mode is selected.
- Fault Code transmission is enabled (register bit 16.2 = 1).
- Either Signal Detect indicates no signal, or the receive PLL cannot lock.
- Loopback is not enabled.

5.2.2 MII Data Interface

The LXT971A PHY supports a standard Media Independent Interface (MII). The MII consists of a data interface and a management interface. The MII Data Interface passes data between the LXT971A PHY and a Media Access Controller (MAC). Separate parallel buses are provided for transmit and receive. This interface operates at either 10 Mbps or 100 Mbps. The speed is set automatically, once the operating conditions of the network link have been determined. For details, see [Section 5.6, MII Operation, on page 36](#).

Increased MII Drive Strength. A higher Media Independent Interface (MII) drive strength may be desired in some designs to drive signals over longer PCB trace lengths, or over high-capacitive loads, through multiple vias, or through a connector. The MII drive strength in the LXT971A PHY can be increased by setting register bit 26.11 through software control. Setting register bit 26.11 = 1 through the MDC/MDIO interface sets the MII pins (RXD[3:0], RX_DV, RX_CLK, RX_ER, COL, CRS, and TX_CLK) to a higher drive strength.

5.2.3 Configuration Management Interface

The LXT971A PHY provides both an MDIO interface and a reduced hardware control interface for device configuration and management.

5.2.3.1 MDIO Management Interface

MDIO management interface topics include the following:

- [Section 5.2.3.1.1, MDIO Addressing](#)
- [Section 5.2.3.1.2, MDIO Frame Structure](#)
- [Section 5.2.3.1.3, MII Interrupts](#)

The LXT971A PHY supports the IEEE 802.3 MII Management Interface also known as the Management Data Input/Output (MDIO) Interface. This interface allows upper-layer devices to monitor and control the state of the LXT971A PHY. The MDIO interface consists of a physical connection, a specific protocol that runs across the connection, and an internal set of addressable registers.

Some registers are required and their functions are defined by the IEEE 802.3 standard. The LXT971A PHY also supports additional registers for expanded functionality. The LXT971A PHY supports multiple internal registers, each of which is 16 bits wide. Specific register bits are referenced using an "X.Y" notation, where X is the register number (0-31) and Y is the bit number (0-15).

The physical interface consists of a data line (MDIO) and clock line (MDC). Operation of this interface is controlled by the MDDIS input pin. When MDDIS is High, the MDIO read and write operations are disabled and the Hardware Control Interface provides primary configuration control. When MDDIS is Low, the MDIO port is enabled for both read and write operations and the Hardware Control Interface is not used.

5.2.3.1.1 MDIO Addressing

The MDIO addressing protocol allows a controller to communicate with multiple PHYs. Pins ADDR[4:0] can be used to determine the PHY device address that is selected.

5.2.3.1.2 MDIO Frame Structure

The physical interface consists of a data line (MDIO) and clock line (MDC). The frame structure is shown in Figure 4 and Figure 5 (Read and Write).

MDIO Interface timing is given in Section 7.0, *Electrical Specifications*.

Figure 4 Management Interface Read Frame Structure

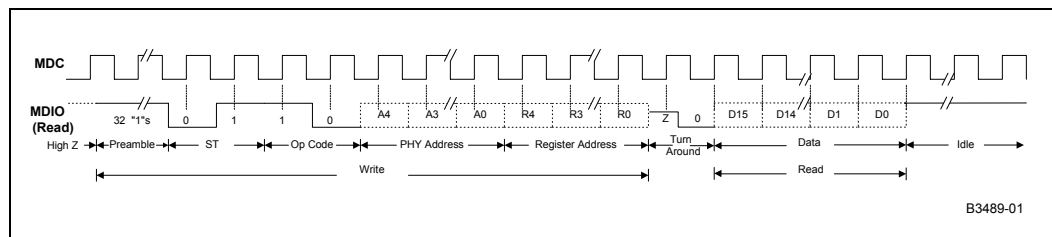
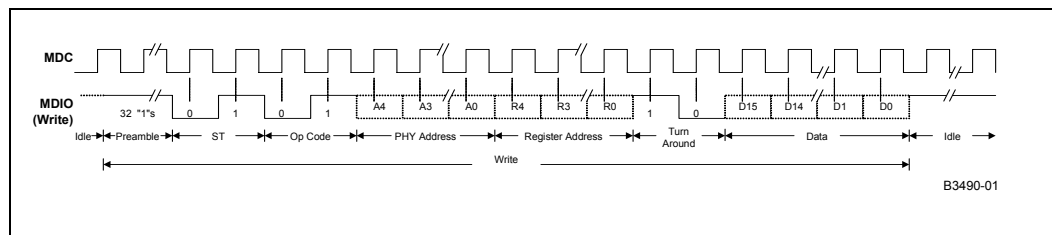

Figure 5 Management Interface Write Frame Structure



5.2.3.1.3 MII Interrupts

Figure 6 shows the MII interrupt logic. The LXT971A PHY provides a hardware interrupt pin (MDINT_L) and two dedicated interrupt registers, Register 18 and Register 19.

- Register 18 provides interrupt enable and mask functions. Setting register bit 18.1 = 1 enables the device to request interrupt via the MDINT_L pin. An active Low on this pin indicates a status change on the LXT971A PHY. Interrupts may be caused by any of the following four conditions:
 - Auto-negotiation complete
 - Speed status change
 - Duplex status change
 - Link status change
- Register 19 provides the interrupt status.

Figure 6 MII Interrupt Logic

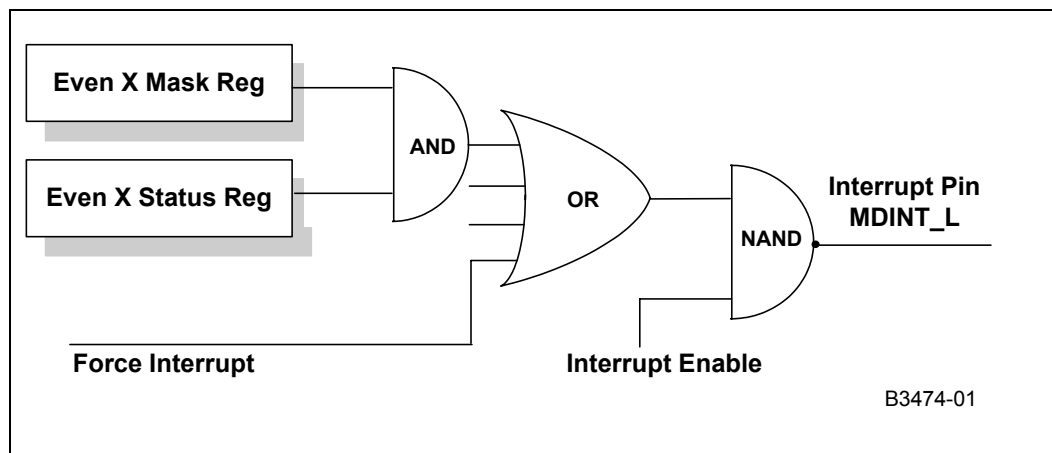

5.2.3.1.4 MII Status Change Register

MII status change is indicated in Register 19 by any of the following four conditions:

- Auto-negotiation complete
- Speed status change
- Duplex status change
- Link status change

5.2.3.2 Hardware Control Interface

The LXT971A PHY provides a Hardware Control Interface for applications where the MDIO is not desired. The Hardware Control Interface uses the hardware configuration pins to set device configuration. For details, see Section 5.4.4, *Hardware Configuration Settings*, on page 33.

5.3 Operating Requirements

5.3.1 Power Requirements

The LXT971A PHY requires three power supply inputs:

- VCCA
- VCCD

- VCCIO

The digital and analog circuits require 3.3 V supplies (VCCA and VCCD). These inputs may be supplied from a single source. Each supply input must be de-coupled to ground.

An additional supply may be used for the MII (VCCIO). The supply may be either 2.5 V or 3.3 V. Also, the inputs on the MII interface are tolerant to 5 V signals from the controller on the other side of the MII interface. For MII I/O characteristics, see [Table 24, Digital I/O Characteristics¹ - MII Pins](#), on page 62.

Notes:

1. Bring up power supplies as close to the same time as possible.
2. As a matter of good practice, keep power supplies as clean as possible.

5.3.2 Clock Requirements

5.3.2.1 External Crystal/Oscillator

The LXT971A PHY requires a reference clock input that is used to generate transmit signals and recover receive signals. It may be provided by either of two methods: by connecting a crystal across the oscillator pins (XI and XO) with load capacitors, or by connecting an external clock source to pin XI.

The connection of a clock source to the XI pin requires the XO pin to be left open. To minimize transmit jitter, Cortina recommends a crystal-based clock instead of a derived clock (that is, a PLL-based clock).

A crystal is typically used in NIC applications. An external 25 MHz clock source, rather than a crystal, is frequently used in switch applications. For clock timing requirements, see [Table 25, I/O Characteristics - REFCLK/XI and XO Pins](#), on page 63.

5.3.2.2 MDIO Clock

The MII management channel (MDIO) also requires an external clock. The managed data clock (MDC) speed is a maximum of 8 MHz.

5.4 Initialization

This section includes the following topics:

- [Section 5.4.1, MDIO Control Mode and Hardware Control Mode](#)
- [Section 5.4.2, Reduced-Power Modes](#)
- [Section 5.4.3, Reset](#)
- [Section 5.4.4, Hardware Configuration Settings](#)

When the LXT971A PHY is first powered on, reset, or encounters a link failure state, it checks the MDIO register configuration bits to determine the line speed and operating conditions to use for the network link.

[Table 13](#) shows the LXT971A PHY initialization sequence. The configuration bits may be set by the Hardware Control or MDIO interface.

Figure 7 Initialization Sequence

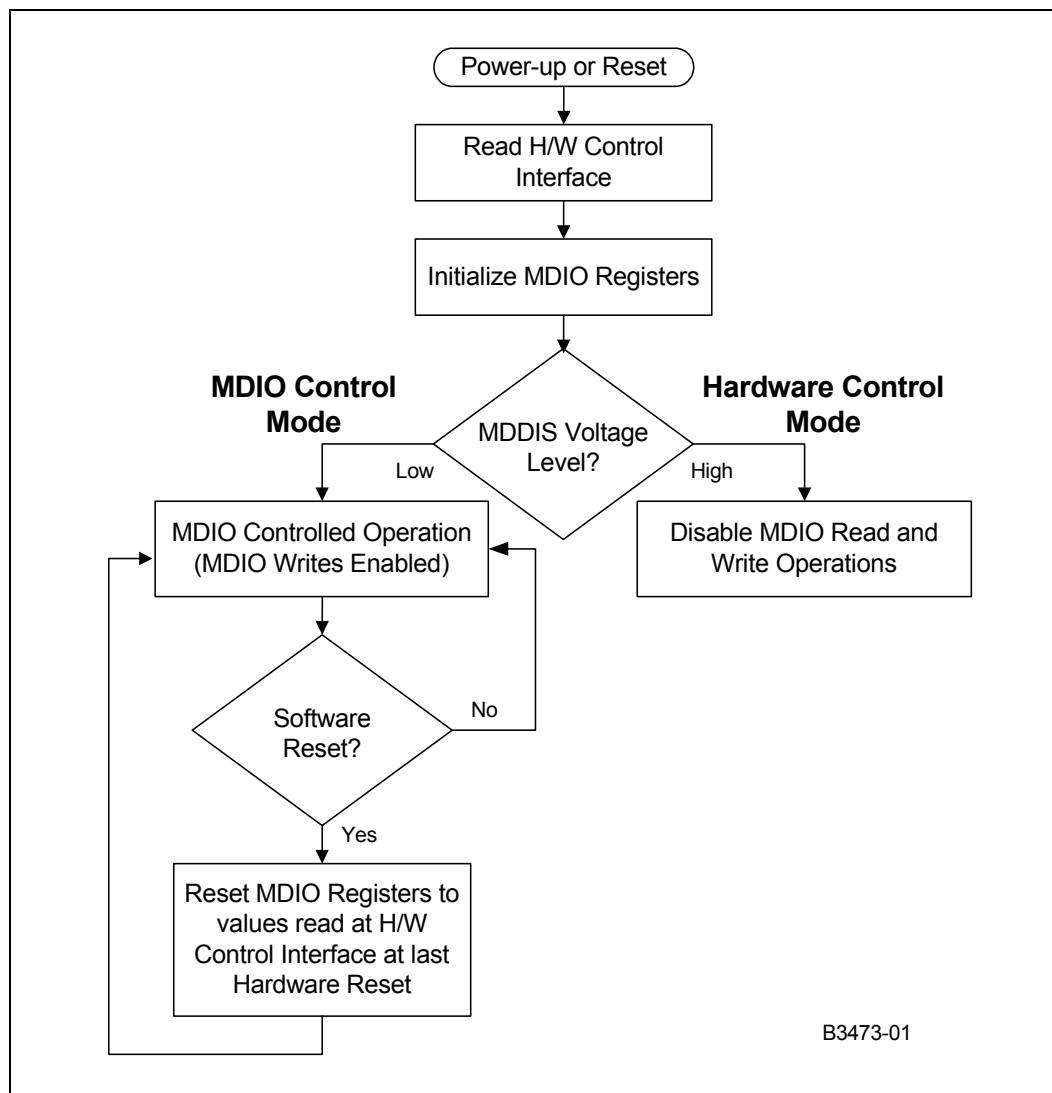

5.4.1 MDIO Control Mode and Hardware Control Mode

In the MDIO Control mode, the LXT971A PHY reads the Hardware Control Interface pins to set the initial (default) values of the MDIO registers. Once the initial values are set, bit control reverts to the MDIO interface.

The following modes are available using either Hardware Control or MDIO control:

- Force network link to 100BASE-FX (Fiber)
- Force network link operation to:
 - 100BASE-TX, Full-Duplex
 - 100BASE-TX, Half-Duplex
 - 10BASE-T, Full-Duplex

- 10BASE-T, Half-Duplex
 - Allow auto-negotiation/parallel-detection

In the Hardware Control Mode, the LXT971A PHY disables direct-write operations to the MDIO registers through the MDIO Interface.

On power-up or hardware reset, the LXT971A PHY reads the Hardware Control Interface pins and sets the MDIO registers accordingly.

When the network link is forced to a specific configuration, the LXT971A PHY immediately begins operating the network interface as commanded. When auto-negotiation is enabled, the LXT971A PHY begins the auto-negotiation/parallel-detection operation.

5.4.2 Reduced-Power Modes

This section discusses the LXT971A PHY reduced-power modes.

5.4.2.1 Hardware Power Down

The hardware power-down mode is controlled by the PWRDWN pin. When PWRDWN is High, the following conditions are true:

- The LXT971A PHY network port and clock are shut down.
- All outputs are tristated.
- All weak pad pull-up and pull-down resistors are disabled.
- The MDIO registers are not accessible.

5.4.2.2 Software Power Down

Software power-down control is provided by register bit 0.11 in the Control Register. During soft power-down, the following conditions are true:

- The network port is shut down.
- The MDIO registers remain accessible.

5.4.2.3 Sleep Mode

The LXT971A PHY supports a power-saving sleep mode. Sleep mode is enabled when SLEEP is asserted via pin 32(LQFP)/H7(PBGA). The value of pin 32/H7 can be overridden by register bit 16.6 in managed mode as listed in [Table 56, Configuration Register - Address 16, Hex 10, on page 86](#). The LXT971A PHY enters into sleep mode when SLEEP is enabled and no energy is detected on the twisted-pair input for 1 to 3 seconds. (The time is controlled by register bits 16.4:3 in the Configuration Register, with a default of 3.04 seconds.)

During this mode, the LXT971A PHY still responds to management transactions (MDC/MDIO). In this mode the power consumption is minimized, and the supply current is reduced below the maximum value. If the LXT971A PHY detects activity on the twisted-pair inputs, it comes out of the sleep state and checks for link. If no link is detected in from 1 to 3 seconds (the time is programmable) it reverts to the low power sleep state.

Note: Sleep mode is not functional in fiber network applications.

5.4.3 Reset

The LXT971A PHY provides both hardware and software resets, each of which manage differently the configuration control of auto-negotiation, speed, and duplex-mode selection.

For a software reset, register bit 0.15 = 1. For register bit definitions used for software reset, see [Table 46, Control Register - Address 0, Hex 0, on page 79](#).

- During a software reset, bit settings in [Table 50, Auto-Negotiation Advertisement Register - Address 4, Hex 4, on page 82](#) are not re-read from the LXT971A PHY configuration pins. Instead, the bit settings revert to the values that were read in during the last hardware reset. Therefore, any changes to pin values made since the last hardware reset are not detected during a software reset.
- During a software reset, registers are available for reading. To see when the LXT971A PHY has completed reset, the reset bit can be polled (that is, register bit 0.15 = 0).

For pin settings used during a hardware reset, see [Section 5.4.4, Hardware Configuration Settings](#). During a hardware reset, configuration settings for auto-negotiation and speed are read in from pins, and register information is unavailable for 1 ms after de-assertion of the reset.

5.4.4 Hardware Configuration Settings

The LXT971A PHY provides a hardware option to set the initial device configuration. As listed in [Table 13](#), the hardware option uses the hardware configuration pins, the settings for which provide control bits.

Table 13 Hardware Configuration Settings

Desired Mode			LED/CFG Pin Settings ¹			Resulting register bit Values							
						Control Register			Auto-Negotiation Advertisement Register				
Auto-Neg.	Speed (Mbps)	Duplex	1	2	3	Auto-Neg. 0.12	Speed 0.13	Full-Duplex 0.8	100 BASE-TX Full-Duplex 4.8	100 BASE-TX 4.7	10 BASE-T Full-Duplex 4.6	10 BASE-T 4.5	
Disabled	10	Half	L	L	L	0	0	0	N/A Auto-Negotiation Advertisement				
		Full	L	L	H		0	1					
	100	Half	L	H	L		1	0					
		Full	L	H	H		1	1					
Enabled	100 Only	Half	H	L	L	1	1	0	0	1	0	0	
		Full/Half	H	L	H		1	1	1	1	0	0	
	10/100	Half Only	H	H	L		1	0	0	1	0	1	
		Full or Half	H	H	H		1	1	1	1	1	1	

1. L = Low, and H = High. For LED/CFG pin assignments, see [Section 3.0, Ball and Pin Assignments](#)

As shown in [Figure 8](#), the LED drivers can operate as either open-drain or open-source circuits.

Figure 8 Hardware Configuration Settings

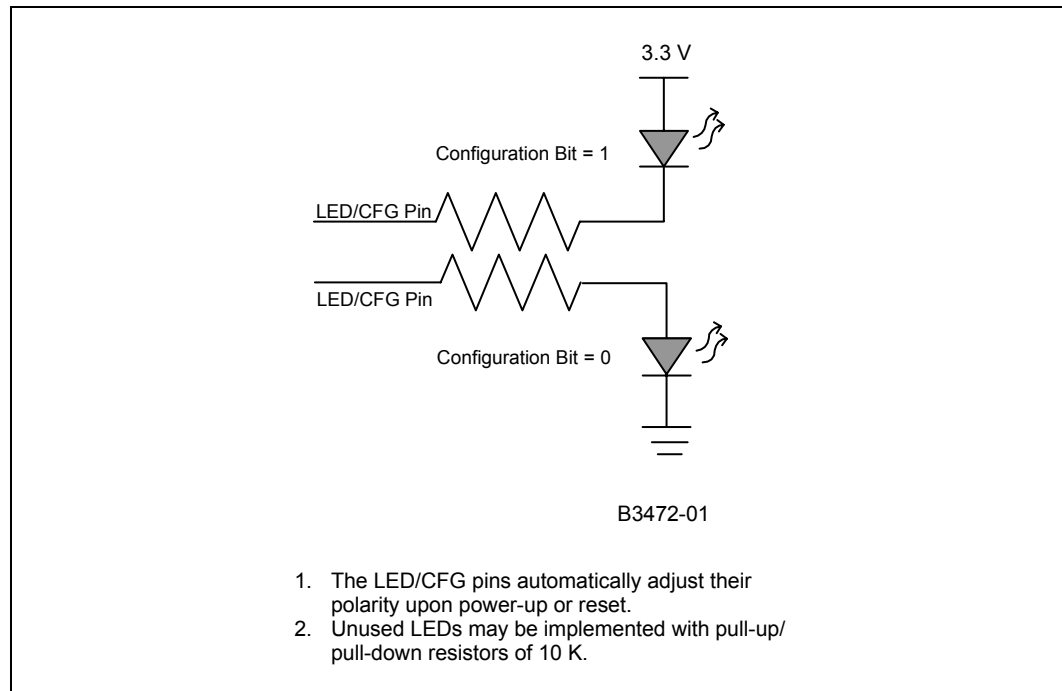

5.5 Establishing Link

Figure 9 shows an overview of link establishment for the LXT971A PHY.

Note: When a link is established by using parallel detection, the LXT971A PHY sets the duplex mode to half-duplex, as defined by the IEEE 802.3 standard.

Figure 9 Link Establishment Overview

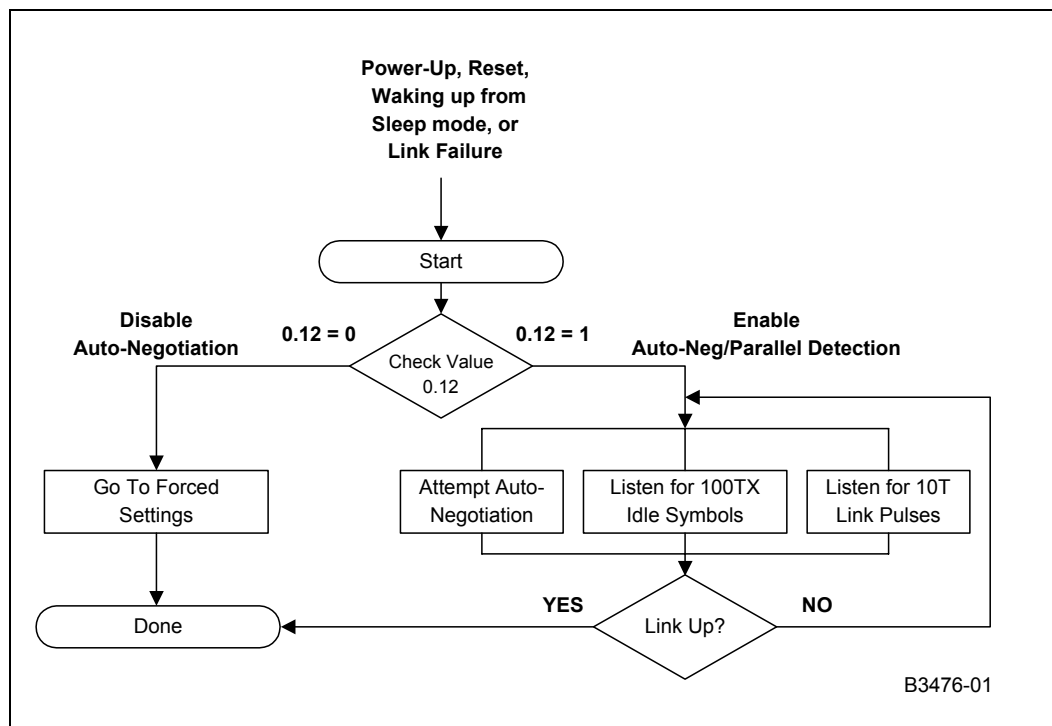

5.5.1 Auto-Negotiation

If not configured for forced operation, the LXT971A PHY attempts to auto-negotiate with its link partner by sending Fast Link Pulse (FLP) bursts. Each burst consists of up to 33 link pulses spaced 62.5 μ s apart. Odd link pulses (clock pulses) are always present. Even link pulses (data pulses) may be absent or present to indicate a ‘0’ or a ‘1’. Each FLP burst exchanges 16 bits of data, which are referred to as a “link code word”. All devices that support auto-negotiation must implement the “Base Page” defined by the IEEE 802.3 standard (Registers 4 and 5).

The LXT971A PHY also supports the optional “Next Page” function as listed in [Table 53, Auto-Negotiation Next Page Transmit Register - Address 7, Hex 7, on page 84](#) and [Table 54, Auto-Negotiation Link Partner Next Page Receive Register - Address 8, Hex 8, on page 85](#).

5.5.1.1 Base Page Exchange

By exchanging Base Pages, the LXT971A PHY and its link partner communicate their capabilities to each other. Both sides must receive at least three consecutive identical base pages for negotiation to continue. Each side identifies the highest common capabilities that both sides support, and each side configures itself accordingly.

5.5.1.2 Manual Next Page Exchange

“Next Page Exchange” information is additional information that exceeds the information required by Base Page exchange and that is sent by “Next Pages”. The LXT971A PHY fully supports the IEEE 802.3 standard method of negotiation through the Next Page exchange.

The Next Page exchange uses Register 7 to send information and Register 8 to receive it. Next Page exchange occurs only if both ends of the link partners advertise their ability to exchange Next Pages. register bit 6.1 is used to make manual next page exchange easier for software. This register bit is cleared when a new negotiation occurs, preventing the user from reading an old value in Register 6 and assuming there is valid information in Registers 5 and 8.

5.5.1.3 Controlling Auto-Negotiation

When auto-negotiation is controlled by software, Cortina recommends the following steps:

1. After power-up, power-down, or reset, the power-down recovery time (specified in [Table 44, RESET_L Pulse Width and Recovery Timing, on page 77](#)) must be exhausted before proceeding.
2. Set the Auto-Negotiation Advertisement register bits.
3. Enable auto-negotiation. (Set MDIO register bit 0.12 = 1.)
4. To ensure proper operation, enable or restart auto-negotiation as soon as possible after writing to Register 4.

5.5.2 Parallel Detection

In parallel with auto-negotiation, the LXT971A PHY also monitors for 10 Mbps Normal Link Pulses (NLP) or 100 Mbps Idle symbols. If either symbol is detected, the device automatically reverts to the corresponding speed in half-duplex mode. Parallel detection allows the LXT971A PHY to communicate with devices that do not support auto-negotiation.

When parallel detection resolves a link, the link must be established in half-duplex mode. According to IEEE standards, the forced link partner cannot be configured to full-duplex. If the auto-negotiation link partner does not advertise half-duplex capability at the speed of the forced link partner, link is not established. The IEEE Standard prevents full-duplex-to-half-duplex link connections.

5.6 MII Operation

This section includes the following topics:

- [Section 5.6.1, MII Clocks](#)
- [Section 5.6.2, Transmit Enable](#)
- [Section 5.6.3, Receive Data Valid](#)
- [Section 5.6.4, Carrier Sense](#)
- [Section 5.6.5, Error Signals](#)
- [Section 5.6.6, Collision](#)
- [Section 5.6.7, Loopback](#)

The LXT971A PHY implements the Media Independent Interface (MII) as defined by the IEEE 802.3 standard. Separate channels are provided for transmitting data from the MAC to the LXT971A PHY (TXD), and for passing data received from the line (RXD) to the MAC. Each channel has its own clock, data bus, and control signals.

The following signals are used to pass received data to the MAC:

- COL
- CRS
- RX_CLK
- RX_DV
- RX_ER
- RXD[3:0]

The following signals are used to transmit data from the MAC:

- TX_CLK
- TX_EN
- TX_ER
- TXD[3:0]

The LXT971A PHY supplies both clock signals as well as separate outputs for carrier sense and collision. Data transmission across the MII is normally implemented in 4-bit-wide nibbles.

5.6.1 MII Clocks

The LXT971A PHY is the master clock source for data transmission, and it supplies both MII clocks (RX_CLK and TX_CLK). It automatically sets the clock speeds to match link conditions.

- When the link is operating at 100 Mbps, the clocks are set to 25 MHz.
- When the link is operating at 10 Mbps, the clocks are set to 2.5 MHz.

Figure 10 through Figure 12 show the clock cycles for each mode.

Note: The transmit data and control signals must always be synchronized to TX_CLK by the MAC. The LXT971A PHY samples these signals on the rising edge of TX_CLK.

Figure 10 Clocking for 10BASE-T

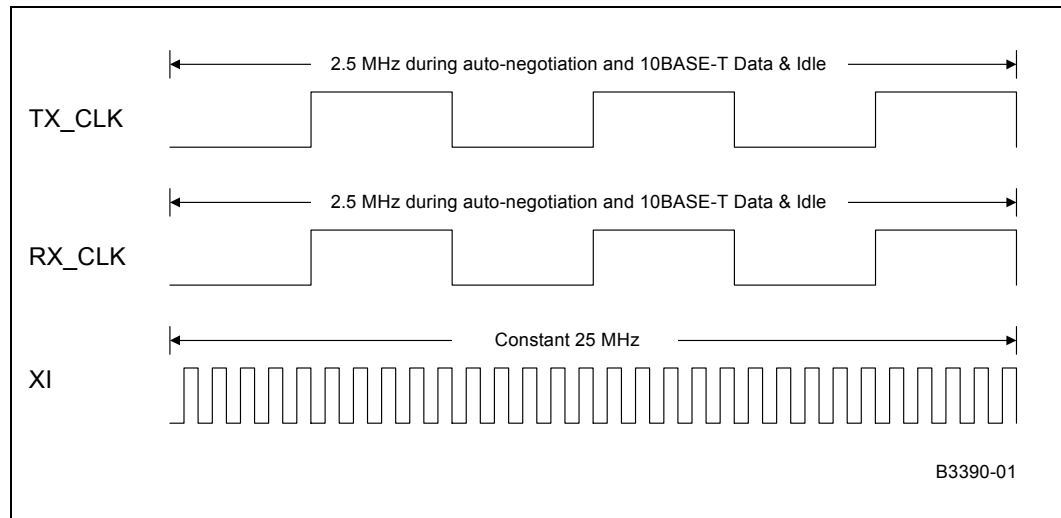

Figure 11 Clocking for 100BASE-X

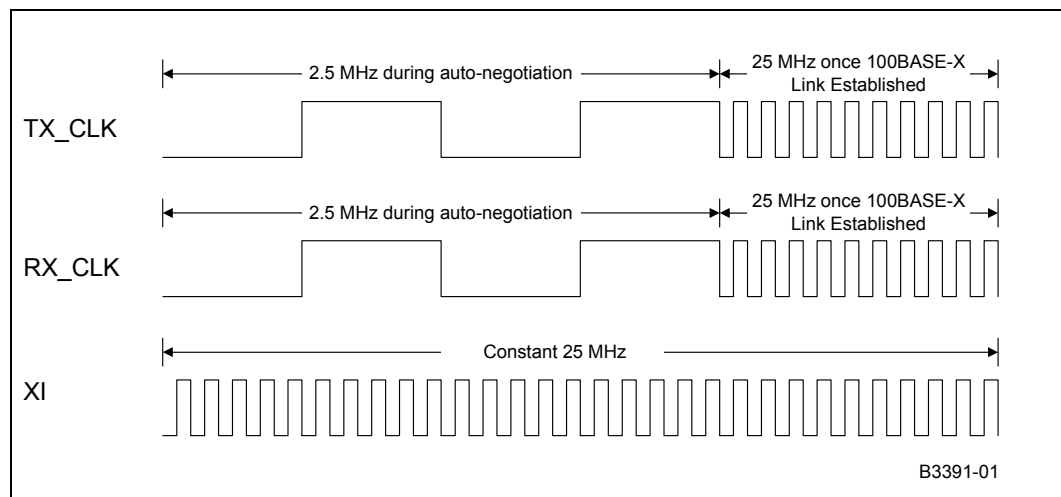
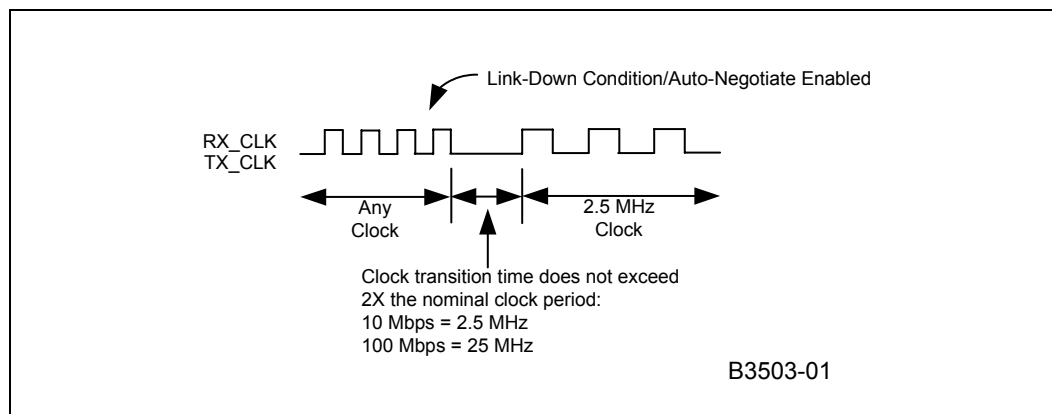

Figure 12 Clocking for Link Down Clock Transition



5.6.2 Transmit Enable

The MAC must assert TX_EN the same time as the first nibble of preamble and de-assert TX_EN after the last nibble of the packet.

5.6.3 Receive Data Valid

The LXT971A PHY asserts RX_DV when it receives a valid packet. Timing changes depend on line operating speed:

- For 100BASE-TX links, RX_DV is asserted from the first nibble of preamble to the last nibble of the data packet.
- For 10BASE-T links, the entire preamble is truncated. RX_DV is asserted with the first nibble of the Start of Frame Delimiter (SFD) "5D" and remains asserted until the end of the packet.

5.6.4 Carrier Sense

Carrier Sense (CRS) is an asynchronous output.

- CRS is always generated when the LXT971A PHY receives a packet from the line.
- CRS is also generated when the LXT971A PHY is in half-duplex mode when a packet is transmitted.

Table 14 summarizes the conditions for assertion of carrier sense, data loopback, and collision signals. Carrier sense is not generated when a packet is transmitted and in full-duplex mode.

Table 14 Carrier Sense, Loopback, and Collision Conditions

Speed	Duplex Condition	Carrier Sense	Test Loop-back ^{1, 2}	Operational Loop-back ^{1, 2}	Collision
100 Mbps	Full-Duplex	Receive Only	Yes	No	None
	Half-Duplex	Transmit or Receive	No	No	Transmit and Receive
10 Mbps	Full-Duplex	Receive Only	Yes	No	None
	Half-Duplex, register bit 16.8 = 0	Transmit or Receive	Yes	Yes	Transmit and Receive
	Half-Duplex, register bit 16.8 = 1	Transmit or Receive	No	No	Transmit and Receive

1. Test Loopback is enabled when register bit 0.14 = 1.
 2. For descriptions of Test Loopback and Operational Loopback, see [Section 5.6.7, Loopback, on page 40](#).

5.6.5 Error Signals

When the LXT971A PHY is in 100 Mbps mode and receives an invalid symbol from the network, it asserts RX_ER and drives “0101” on the RXD pins.

When the MAC asserts TX_ER, the LXT971A PHY drives “H” symbols out on the TPFOP/N pins.

5.6.6 Collision

The LXT971A PHY asserts its collision signal asynchronously to any clock whenever the line state is half-duplex and the transmitter and receiver are active at the same time. [Table 14](#) summarizes the conditions for assertion of carrier sense, data loopback, and collision signals.

5.6.7 Loopback

The LXT971A PHY provides the following loopback functions:

- [Section 5.6.7.1, Operational Loopback](#)
- [Section 5.6.7.2, Internal Digital Loopback \(Test Loopback\)](#)

[Figure 13](#) shows LXT971A PHY operational and test loopback paths. (An internal digital loopback path is not shown.) For more information on loopback functions, see [Table 14, Carrier Sense, Loopback, and Collision Conditions, on page 40](#).)

Figure 13 Loopback Paths

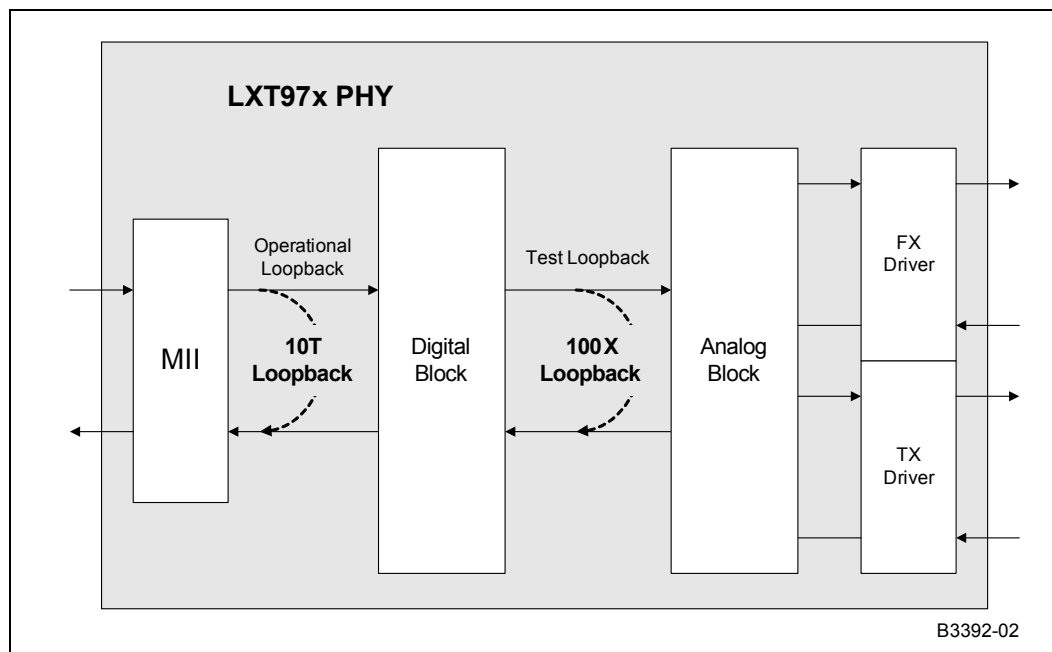

5.6.7.1 Operational Loopback

- Operational loopback is provided for 10 Mbps half-duplex links when register bit 16.8 = 0. Data that the MAC (TXData) transmits loops back on the receive side of the MII (RXData).
- Operational loopback is not provided for 100 Mbps links, full-duplex links, or when Register 16.8 = 1.

5.6.7.2 Internal Digital Loopback (Test Loopback)

A test loopback function is provided for diagnostic testing of the LXT971A PHY. During test loopback, twisted-pair and fiber interfaces are disabled. Data transmitted by the MAC is internally looped back by the LXT971A PHY and returned to the MAC.

Test loopback is available for both 100BASE-TX and 10BASE-T operation, and is enabled by setting the following register bits:

- register bit 0.14 = 1 (Setting to enable loopback mode)
- register bit 0.8 = 1 (Setting for full-duplex mode)
- register bit 0.12 = 0 (Disable auto-negotiation)

Test loopback is also available for 100BASE-FX operation. Test loopback in this mode is enabled by setting register bit 0.14 = 1 and tying the SD input to an LVPECL logic High value (2.4 V).

Note: Parallel detection can resolve the PHY configuration.

5.7 100 Mbps Operation

5.7.1 100BASE-X Network Operations

During 100BASE-X operation, the LXT971A PHY transmits and receives 5-bit symbols across the network link.

Figure 14 shows the structure of a standard frame packet in 100BASE-X mode. When the MAC is not actively transmitting data, the LXT971A PHY sends out Idle symbols on the line.

As Figure 14 shows, the MAC starts each transmission with a preamble pattern. As soon as the LXT971A PHY detects the start of preamble, it transmits a Start-of-Stream Delimiter (SSD, symbols J and K) to the network. It then encodes and transmits the rest of the packet, including the balance of the preamble, the SFD, packet data, and CRC.

Once the packet ends, the LXT971A PHY transmits the End-of-Stream Delimiter (ESD, symbols T and R) and then returns to transmitting Idle symbols.

For details on the symbols used, see 4B/5B coding listed in Table 15, 4B/5B Coding, on page 46.

Figure 14 100BASE-X Frame Format

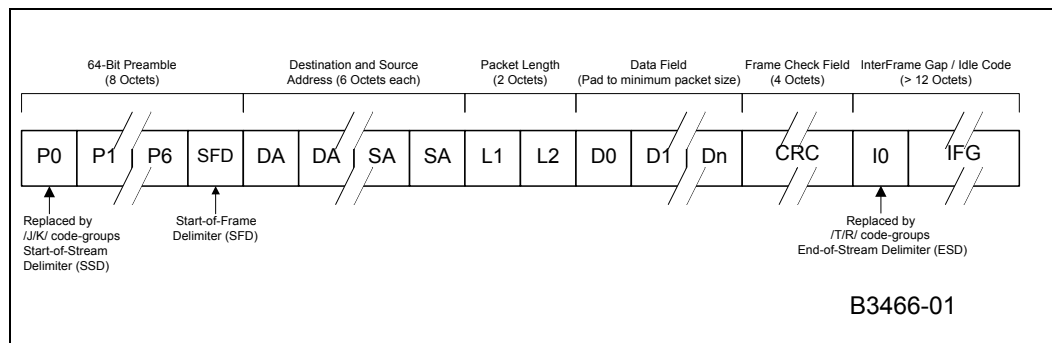

As shown in Figure 15, in 100BASE-TX mode, the LXT971A PHY scrambles and transmits the data to the network using MLT-3 line code. MLT-3 signals received from the network are de-scrambled, decoded, and sent across the MII to the MAC.

Figure 15 100BASE-TX Data Path

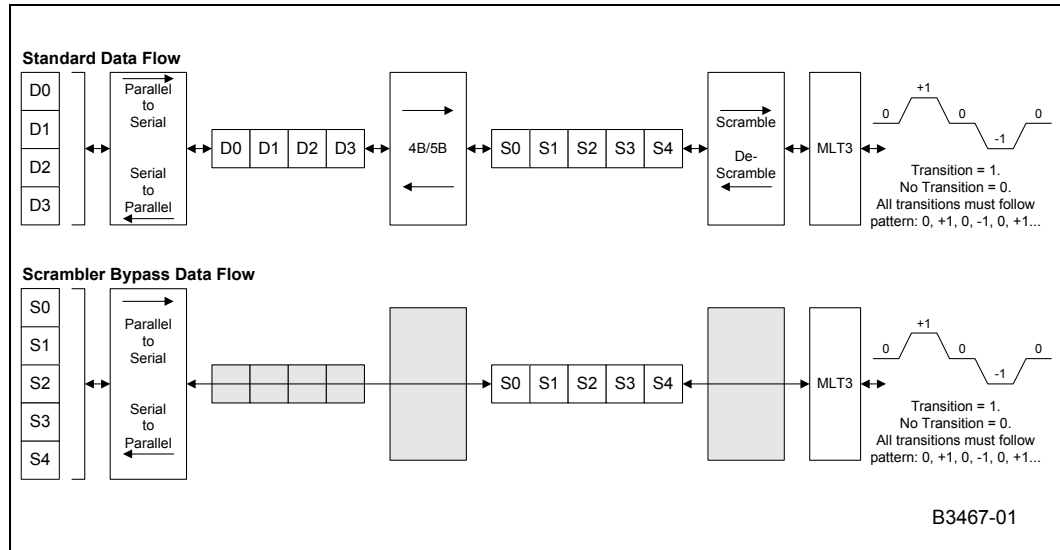

Note: In 100BASE-FX mode, the LXT971A PHY transmits and receives NRZI signals across the LVPECL interface. An external 100BASE-FX PHY module is required to complete the fiber connection. To enable 100BASE-FX operation, auto-negotiation must be disabled and fiber mode selected.

Figure 16 shows normal reception with no errors.

Figure 16 100BASE-TX Reception with No Errors

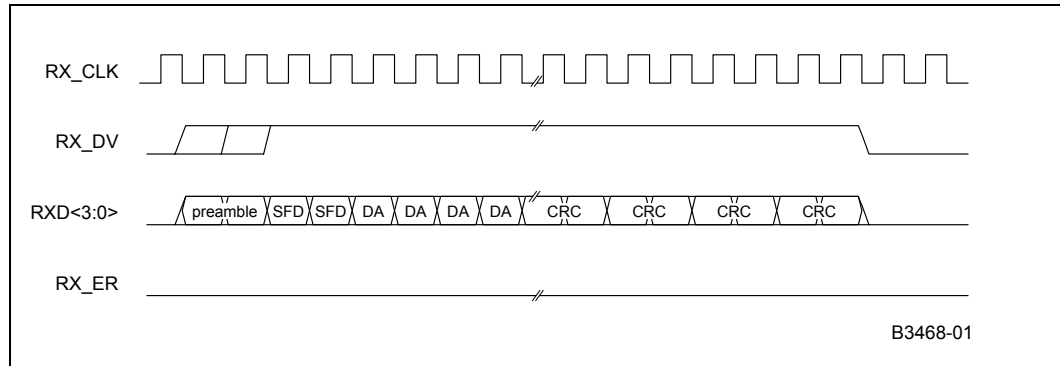

As shown in Figure 17, when the LXT971A PHY receives invalid symbols from the line, it asserts RX_ER.

Figure 17 100BASE-TX Reception with Invalid Symbol

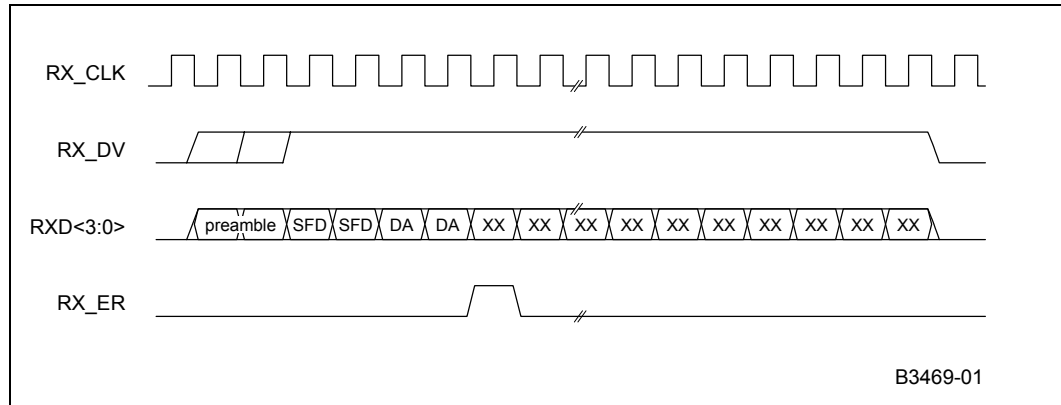

5.7.2 Collision Indication

Figure 18 shows normal transmission.

Figure 18 100BASE-TX Transmission with No Errors

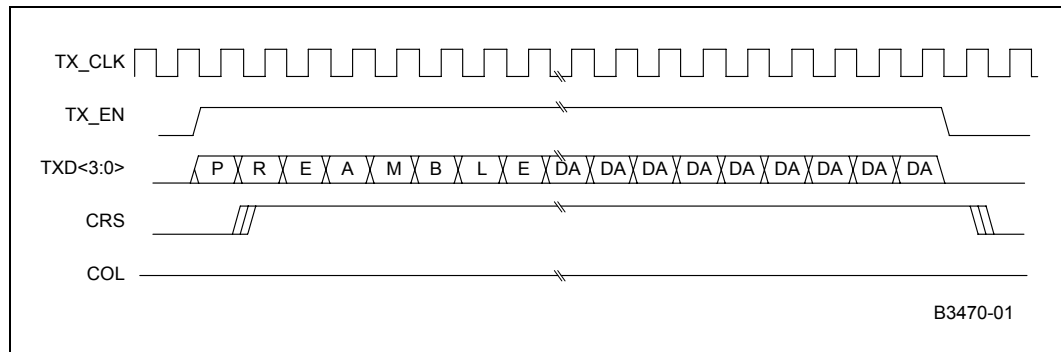

Upon detection of a collision, the COL output is asserted and remains asserted for the duration of the collision as shown in Figure 19.

Figure 19 100BASE-TX Transmission with Collision

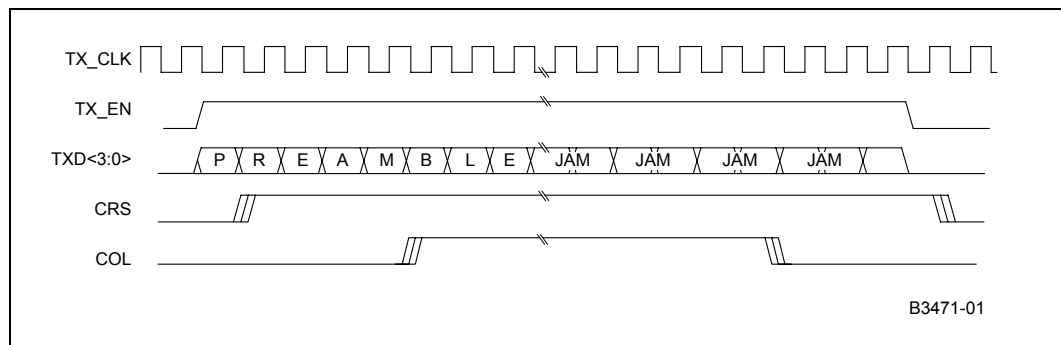

5.7.3 100BASE-X Protocol Sublayer Operations

With respect to the 7-layer communications model, the LXT971A PHY is a Physical Layer 1 (PHY) device.

The LXT971A PHY implements the following sublayers of the reference model defined by the IEEE 802.3 standard, and discussed from the reference model point of view:

- Section 5.7.3.1, *Physical Coding Sublayer*
- Section 5.7.3.2, *Physical Medium Attachment Sublayer*
- Section 5.7.3.3, *Twisted-Pair Physical Medium Dependent Sublayer*
- Section 5.7.3.4, *Fiber PMD Sublayer*

Figure 20 shows the LXT971A PHY protocol sublayers.

Figure 20 Protocol Sublayers

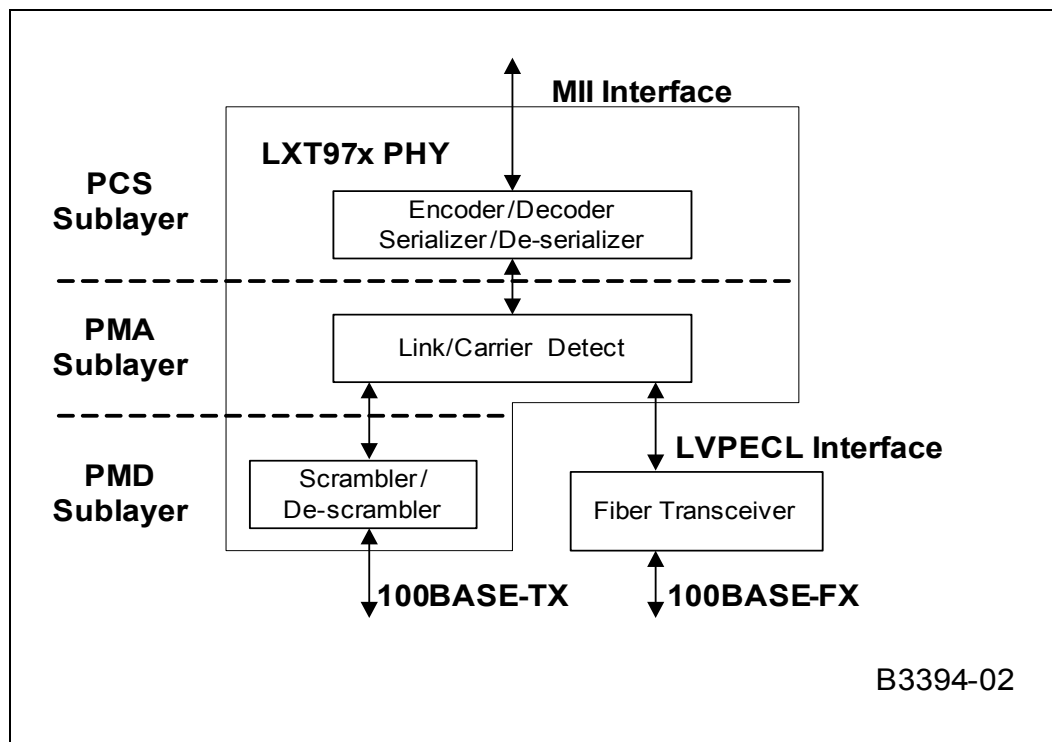

5.7.3.1 Physical Coding Sublayer

The Physical Coding Sublayer (PCS) provides the MII interface, as well as the 4B/5B encoding/decoding function.

For 100BASE-TX and 100BASE-FX operation, the PCS layer provides IDLE symbols to the PMD-layer line driver as long as TX_EN is de-asserted.

5.7.3.1.1 Preamble Handling

When the MAC asserts TX_EN, the PCS substitutes a /J/K symbol pair, also known as the Start-of-Stream Delimiter (SSD), for the first two nibbles received across the MII. The PCS layer continues to encode the remaining MII data, following the 4B/5B coding in Table 15, until TX_EN is de-asserted. It then returns to supplying IDLE symbols to the line driver.

In the receive direction, the PCS layer performs the opposite function, substituting two preamble nibbles for the SSD. In 100 Mbps operation, preamble is always passed through the PCS layer to the MII interface.

Table 15 4B/5B Coding (Sheet 1 of 2)

Code Type	4B Code 3 2 1 0	Name	5B Code 4 3 2 1 0	Interpretation
DATA	0 0 0 0	0	1 1 1 1 0	Data 0
	0 0 0 1	1	0 1 0 0 1	Data 1
	0 0 1 0	2	1 0 1 0 0	Data 2
	0 0 1 1	3	1 0 1 0 1	Data 3
	0 1 0 0	4	0 1 0 1 0	Data 4
	0 1 0 1	5	0 1 0 1 1	Data 5
	0 1 1 0	6	0 1 1 1 0	Data 6
	0 1 1 1	7	0 1 1 1 1	Data 7
	1 0 0 0	8	1 0 0 1 0	Data 8
	1 0 0 1	9	1 0 0 1 1	Data 9
	1 0 1 0	A	1 0 1 1 0	Data A
	1 0 1 1	B	1 0 1 1 1	Data B
	1 1 0 0	C	1 1 0 1 0	Data C
	1 1 0 1	D	1 1 0 1 1	Data D
	1 1 1 0	E	1 1 1 0 0	Data E
1 1 1 1	F	1 1 1 0 1	Data F	
IDLE	undefined	I ¹	1 1 1 1 1	Used as inter-stream fill code
CONTROL	0 1 0 1	J ²	1 1 0 0 0	Start-of-Stream Delimiter (SSD), part 1 of 2
	0 1 0 1	K ²	1 0 0 0 1	Start-of-Stream Delimiter (SSD), part 2 of 2
	Undefined	T ³	0 1 1 0 1	End-of-Stream Delimiter (ESD), part 1 of 2
	Undefined	R ³	0 0 1 1 1	End-of-Stream Delimiter (ESD), part 2 of 2

1. The /I/ (Idle) code group is sent continuously between frames.
 2. The /J/ and /K/ (SSD) code groups are always sent in pairs, and /K/ follows /J/.
 3. The /T/ and /R/ (ESD) code groups are always sent in pairs, and /R/ follows /T/.
 4. An /H/ (Error) code group is used to signal an error condition.

Table 15 4B/5B Coding (Sheet 2 of 2)

Code Type	4B Code 3 2 1 0	Name	5B Code 4 3 2 1 0	Interpretation
INVALID	Undefined	H ⁴	0 0 1 0 0	Transmit Error. Used to force signaling errors
	Undefined	Invalid	0 0 0 0 0	Invalid
	Undefined	Invalid	0 0 0 0 1	Invalid
	Undefined	Invalid	0 0 0 1 0	Invalid
	Undefined	Invalid	0 0 0 1 1	Invalid
	Undefined	Invalid	0 0 1 0 1	Invalid
	Undefined	Invalid	0 0 1 1 0	Invalid
	Undefined	Invalid	0 1 0 0 0	Invalid
	Undefined	Invalid	0 1 1 0 0	Invalid
	Undefined	Invalid	1 0 0 0 0	Invalid
	Undefined	Invalid	1 1 0 0 1	Invalid

1. The // (Idle) code group is sent continuously between frames.
2. The /J/ and /K/ (SSD) code groups are always sent in pairs, and /K/ follows /J/.
3. The /T/ and /R/ (ESD) code groups are always sent in pairs, and /R/ follows /T/.
4. An /H/ (Error) code group is used to signal an error condition.

5.7.3.2 Physical Medium Attachment Sublayer

5.7.3.2.1 Link

In 100 Mbps mode, link is established when the descrambler becomes locked and remains locked for approximately 50 ms. Link remains up unless the descrambler receives less than 16 consecutive idle symbols in any 2 ms period. This operation filters out small noise hits that may disrupt the link.

For short periods, MLT-3 idle waveforms meet all criteria for 10BASE-T start delimiters. A working 10BASE-T receive may temporarily indicate link to 100BASE-TX waveforms. However, the PHY does not bring up a permanent 10 Mbps link.

The LXT971A PHY reports link failure through the MII status bits (register bits 1.2 and 17.10) and interrupt functions. Link failure causes the LXT971A PHY to re-negotiate if auto-negotiation is enabled.

5.7.3.2.2 Link Failure Override

The LXT971A PHY normally transmits data packets only if it detects the link is up. Setting register bit 16.14 = 1 overrides this function, allowing the LXT971A PHY to transmit data packets even when the link is down. This feature is provided as a transmit diagnostic tool.

Note: Auto-negotiation must be disabled to transmit data packets in the absence of link. If auto-negotiation is enabled, the LXT971A PHY automatically transmits FLP bursts if the link is down.

Caution: During normal operation, Cortina does not recommend setting register bit 16.14 for 100 Mbps receive functions because receive errors may be generated.

5.7.3.2.3 Carrier Sense

For 100BASE-TX and 100BASE-FX links, a start-of-stream delimiter (SSD) or /J/K symbol pair causes assertion of carrier sense (CRS). An end-of-stream delimiter (ESD) or /T/R symbol pair causes de-assertion of CRS. The PMA layer also de-asserts CRS if IDLE symbols are received without /T/R. However, in this case RX_ER is asserted for one clock cycle when CRS is de-asserted.

Cortina does not recommend using CRS for Interframe Gap (IFG) timing for the following reasons:

- CRS de-assertion time is slightly longer than CRS assertion time. As a result, an IFG interval appears somewhat shorter to the MAC than it actually is on the wire.
- CRS de-assertion is not aligned with TX_EN de-assertion on transmit loopbacks in half-duplex mode.

5.7.3.2.4 Receive Data Valid

The LXT971A PHY asserts RX_DV to indicate that the received data maps to valid symbols. In 100 Mbps operation, RX_DV is active with the first nibble of preamble.

5.7.3.3 Twisted-Pair Physical Medium Dependent Sublayer

The twisted-pair Physical Medium Dependent (PMD) layer provides signal scrambling and de-scrambling functions, line coding and decoding functions (MLT-3 for 100BASE-TX, Manchester for 10BASE-T), as well as receiving, polarity correction, and baseline wander correction functions.

5.7.3.3.1 Scrambler/Descrambler

The purpose of the scrambler/descrambler is to spread the signal power spectrum and further reduce EMI using an 11-bit, data-independent polynomial. The receiver automatically decodes the polynomial whenever IDLE symbols are received.

Scrambler Seeding. Once the transmit data (or Idle symbols) are properly encoded, they are scrambled to further reduce EMI and to spread the power spectrum using an 11-bit scrambler seed. Five seed bits are determined by the PHY address, and the remaining bits are hard coded in the design.

Scrambler Bypass. The scrambler/de-scrambler can be bypassed by setting register bit 16.12 = 1. The scrambler is automatically bypassed when the fiber port is enabled. Scrambler bypass is provided for diagnostic and test support.

5.7.3.3.2 Polarity Correction

The 100 Mbps twisted pair signaling is not polarity sensitive. As a result, the polarity status is not a valid status indicator.

5.7.3.3.3 Baseline Wander Correction

The LXT971A PHY provides a baseline wander correction function for when the LXT971A PHY is under network operating conditions. The MLT3 coding scheme used in 100BASE-TX is by definition “unbalanced”. As a result, the average value of the signal voltage can “wander” significantly over short time intervals (tenths of seconds). This wander can cause receiver errors at long-line lengths (100 meters) in less robust designs. Exact characteristics of the wander are completely data dependent.

The LXT971A PHY baseline wander correction characteristics allow the device to recover error-free data while receiving worst-case packets over all cable lengths.

5.7.3.3.4 Programmable Slew Rate Control

The LXT971A PHY device supports a programmable slew-rate mechanism whereby one of four pre-selected slew rates can be used. (For details, see [Table 62, Transmit Control Register - Address 30, Hex 1E, on page 93.](#)) The slew-rate mechanism allows the designer to optimize the output waveform to match the characteristics of the magnetics.

Note: For hardware control of the slew rate, use the TxSLEW pins.

5.7.3.4 Fiber PMD Sublayer

The LXT971A PHY provides an LVPECL interface for connection to an external 3.3 V or 5 V fiber-optic PHY. (The external PHY provides the PMD function for the optical medium.) The LXT971A PHY uses a 125 Mbaud NRZI format for the fiber interface and does not support 10BASE-FL applications.

5.8 10 Mbps Operation

The LXT971A PHY operates as a standard 10BASE-T PHY and LXT971A PHY supports standard 10 Mbps functions. During 10BASE-T operation, the LXT971A PHY transmits and receives Xilinx* Manchester-encoded data across the network link. When the MAC is not actively transmitting data, the LXT971A PHY drives link pulses onto the line.

In 10BASE-T mode, the polynomial scrambler/de-scrambler is inactive. Manchester-encoded signals received from the network are decoded by the LXT971A PHY and sent across the MII to the MAC.

Note: The LXT971A PHY does not support fiber connections at 10 Mbps.

5.8.1 10BASE-T Preamble Handling

The LXT971A PHY offers two options for preamble handling, selected by register bit 16.5.

- In 10BASE-T mode when register bit 16.5 = 0, the LXT971A PHY strips the entire preamble off of received packets. CRS is asserted coincident with the start of the preamble. RX_DV is held Low for the duration of the preamble. When RX_DV is asserted, the very first two nibbles driven by the LXT971A PHY are the SFD “5D” hex followed by the body of the packet.
- In 10BASE-T mode when register bit 16.5 = 1, the LXT971A PHY passes the preamble through the MII and asserts RX_DV and CRS simultaneously. (In 10BASE-T loopback, the LXT971A PHY loops back whatever the MAC transmits to it, including the preamble.)

5.8.2 10BASE-T Carrier Sense

For 10BASE-T links, CRS assertion is based on reception of valid preamble, and CRS de-assertion is based on reception of an end-of-frame (EOF) marker. register bit 16.7 allows CRS de-assertion to be synchronized with RX_DV de-assertion. For details, see [Table 56, Configuration Register - Address 16, Hex 10, on page 86.](#)

5.8.3 10BASE-T Dribble Bits

The LXT971A PHY handles dribble bits in all modes. If one to four dribble bits are received, the nibble is passed across the MII, padded with ones if necessary. If five to seven dribble bits are received, the second nibble is not sent to the MII bus.

5.8.4 10BASE-T Link Integrity Test

In 10BASE-T mode, the LXT971A PHY always transmits link pulses.

- If the Link Integrity Test function is enabled (the normal configuration), the LXT971A PHY monitors the connection for link pulses. Once link pulses are detected, data transmission is enabled and remains enabled as long as either the link pulses or data transmission continue. If the link pulses stop, the data transmission is disabled.
- If the Link Integrity Test function is disabled (which can be done by setting Configuration register bit 16.14 to '1'), the LXT971A PHY transmits to the connection regardless of detected link pulses.

5.8.5 Link Failure

Link failure occurs if the Link Integrity Test is enabled and link pulses or packets stop being received. If this condition occurs, the LXT971A PHY returns to the auto-negotiation phase if auto-negotiation is enabled. If the Link Integrity Test function is disabled by setting Configuration register bit 16.14 to '1', the LXT971A PHY transmits packets, regardless of link status.

5.8.6 10BASE-T SQE (Heartbeat)

By default, the Signal Quality Error (SQE) or heartbeat function is disabled on the LXT971A PHY. To enable this function, set register bit 16.9 = 1. When this function is enabled, the LXT971A PHY asserts its COL output for 5 to 15 bit times (BT) after each packet. For SQE timing parameters, see [Figure 36, 10BASE-T SQE \(Heartbeat\) Timing](#), on page 73.

5.8.7 10BASE-T Jabber

If a transmission exceeds the jabber timer, the LXT971A PHY disables the transmit and loopback functions. For jabber timing parameters, see [Figure 35, 10BASE-T Jabber and Unjabber Timing](#), on page 73.

The LXT971A PHY automatically exits jabber mode after the unjabber time has expired. This function can be disabled by setting register bit 16.10 = 1.

5.8.8 10BASE-T Polarity Correction

The LXT971A PHY automatically detects and corrects for the condition in which the receive signal (TPFIP/N) is inverted. Reversed polarity is detected if eight inverted link pulses, or four inverted end-of-frame (EOF) markers, are received consecutively. If link pulses or data are not received by the maximum receive time-out period (96 to 128 ms), the polarity state is reset to a non-inverted state.

5.9 Monitoring Operations

5.9.1 Monitoring Auto-Negotiation

Auto-negotiation can be monitored as follows:

- register bit 17.7 is set to '1' once the auto-negotiation process is completed.
- register bits 1.2 and 17.10 are set to '1' once the link is established.

- register bits 17.14 and 17.9 can be used to determine the link operating conditions (speed and duplex).

Note: When the LXT971A PHY detects incorrect polarity for a 10BASE-T operation, register bit 17.5 is set to '1'.

5.9.2 Monitoring Next Page Exchange

The LXT971A PHY offers an Alternate Next Page mode to simplify the next page exchange process. Normally, register bit 6.1 (Page Received) remains set until read. When Alternate Next Page mode is enabled, register bit 6.1 is automatically cleared whenever a new negotiation process takes place. This action prevents the user from reading an old value in bit 6.1 and assuming that Registers 5 and 8 (Partner Ability) contain valid information. Additionally, the LXT971A PHY uses register bit 6.5 to indicate when the current received page is the base page. This information is useful for recognizing when next pages must be resent due to a new negotiation process starting. register bits 6.1 and 6.5 are cleared when read.

5.9.3 LED Functions

The LXT971A PHY has these direct LED driver pins: LED1/CFG1, LED2/CFG2, and LED3/CFG3.

On power-up, all the drivers are asserted for approximately 1 second after reset de-asserts. Each LED driver can be programmed using the LED Configuration Register ([Table 60, LED Configuration Register - Address 20, Hex 14, on page 91](#)) to indicate one of the following conditions:

- Collision Condition
- Duplex Mode
- Link Status
- Operating Speed
- Receive Activity
- Transmit Activity

The LED drivers can also be programmed to display various combined status conditions. For example, setting register bits 20.15:12 to '1101' produces the following combination of Link and Activity indications:

- If Link is down, LED is off. If activity is detected from the MAC, the LED still blinks even if the link is down.
- If Link is up, LED is on.
- If Link is up and activity is detected, the LED blinks at the stretch interval selected by register bits 20.3:2 and continues to blink as long as activity is present.

The LXT971A PHY LED driver pins also provide initial configuration settings. The LED pins are sensitive to polarity and automatically pull up or pull down to configure for either open drain or open collector circuits (10 mA Max current rating) as required by the hardware configuration. For details, see the discussion of [Section 5.4.4, Hardware Configuration Settings, on page 33](#).

5.9.4 LED Pulse Stretching

The LED Configuration Register also provides optional LED pulse stretching to 30, 60, or 100 ms. The pulse stretch time is extended further if the event occurs again during this pulse stretch period.

When an event such as receiving a packet occurs, the event is edge detected and it starts the stretch timer. The LED driver remains asserted until the stretch timer expires. If another event occurs before the stretch timer expires, then the stretch timer is reset and the stretch time is extended.

When a long event (such as duplex status) occurs, the event is edge detected and it starts the stretch timer. When the stretch timer expires, the edge detector is reset so that a long event causes another pulse to be generated from the edge detector, which resets the stretch timer and causes the LED driver to remain asserted.

Figure 21 shows how the stretch operation functions.

Figure 21 LED Pulse Stretching

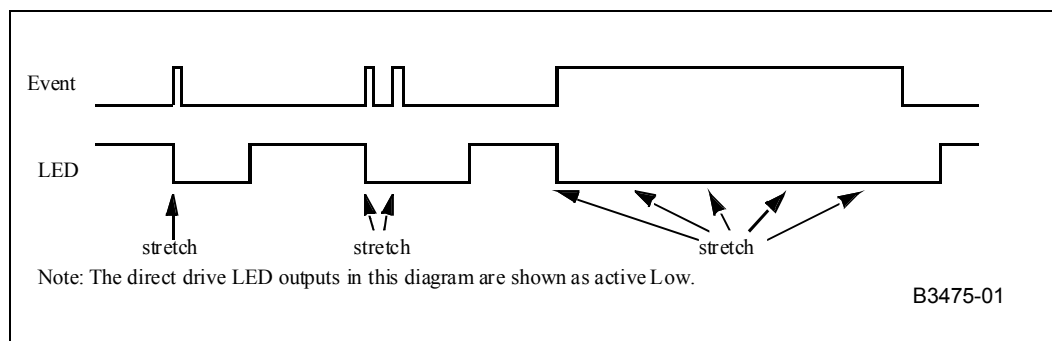

5.10 Boundary Scan (JTAG 1149.1) Functions

The LXT971A PHY includes a IEEE 1149.1 boundary scan test port for board level testing. All digital input, output, and input/output pins are accessible.

Note: For the related BSDL file, contact your local sales office or access the Cortina website (www.cortina-systems.com).

5.10.1 Boundary Scan Interface

The boundary scan interface consists of five pins (TMS, TDI, TDO, TRST_L, and TCK). It includes a state machine, data register array, and instruction register. The TMS and TDI pins are pulled up internally. TCK is pulled down internally. TDO does not have an internal pull-up or pull-down.

5.10.2 State Machine

The TAP controller is a state machine, with 16 states driven by the TCK and TMS pins. Upon reset, the TEST_LOGIC_RESET state is entered. The state machine is also reset when TMS and TDI are high for five TCK periods.

5.10.3 Instruction Register

After the state machine resets, the IDCODE instruction is always invoked. The decode logic ensures the correct data flow to the Data registers according to the current instruction.

Table 17 lists valid LXT971A PHY JTAG instructions.

Table 16 Valid JTAG Instructions

Name	Code	Description	Mode	Data Register
EXTEST	1111 1111 1110 1000	External Test	Test	BSR
IDCODE	1111 1111 1111 1110	ID Code Inspection	Normal	ID REG
SAMPLE	1111 1111 1111 1000	Sample Boundary	Normal	BSR
HIGHZ	1111 1111 1100 1111	Force Float	Normal	Bypass
CLAMP	1111 1111 1110 1111	Control Boundary to 1/0	Test	Bypass
BYPASS	1111 1111 1111 1111	Bypass Scan	Normal	Bypass

5.10.4 Boundary Scan Register

Each Boundary Scan Register (BSR) cell has two stages. A flip-flop and a latch are used for the serial shift stage and the parallel output stage. Table 17 lists the four BSR modes of operation.

Table 17 BSR Mode of Operation

Mode	Description
1	Capture
2	Shift
3	Update
4	System Function

5.10.5 Device ID Register

Table 18 lists the bits for the Device ID register. For the current version of the JEDEC continuation characters, see the specification update for the LXT971A PHY.

Table 18 Device ID Register

Bits 31:28	Bits 27:12	Bits 11:8	Bits 7:1	Bit 0
Version	Part ID (Hex)	JEDEC Continuation Characters	JEDEC ID ¹	Reserved
XXXX	03CB	0000	111 1110	1

1. The JEDEC ID is an 8-bit identifier. The MSB is for parity and is ignored. The JEDEC ID is FE (1111 1110), which becomes 111 1110.

6.0 Application Information

6.1 Magnetics Information

The LXT971A PHY requires a 1:1 ratio for both the receive and transmit transformers. The transformer isolation voltage should be rated at 2 kV to protect the circuitry from static voltages across the connectors and cables. For transformer/magnetics requirements, see [Table 19](#).

Note: Before committing to a specific component, contact the manufacturer for current product specifications and validate the magnetics for the specific application.

Table 19 Magnetics Requirements

Parameter	Min	Nom	Max	Units	Test Condition
Rx turns ratio	–	1 : 1	–	–	–
Tx turns ratio	–	1 : 1	–	–	–
Insertion loss	0.0	0.6	1.1	dB	–
Primary inductance	350	–	–	μH	–
Transformer isolation	–	1.5	–	kV	–
Differential to common mode rejection	40	–	–	dB	0.1 to 60 MHz
	35	–	–	dB	60 to 100 MHz
Return Loss	-16	–	–	dB	30 MHz
	-10	–	–	dB	80 MHz

6.2 Typical Twisted-Pair Interface

[Table 20](#) provides a comparison of the RJ-45 connections for NIC and Switch applications in a typical twisted-pair interface setting.

Table 20 I/O Pin Comparison of NIC and Switch RJ-45 Setups

Symbol	RJ-45	
	Switch	NIC
TPFIP	1	3
TPFIN	2	6
TPFOP	3	1
TPFON	6	2

[Figure 22](#) shows the LXT971A PHY in a typical twisted-pair interface, with the RJ-45 connections crossed over for a Switch configuration.

Figure 22 Typical Twisted-Pair Interface - Switch

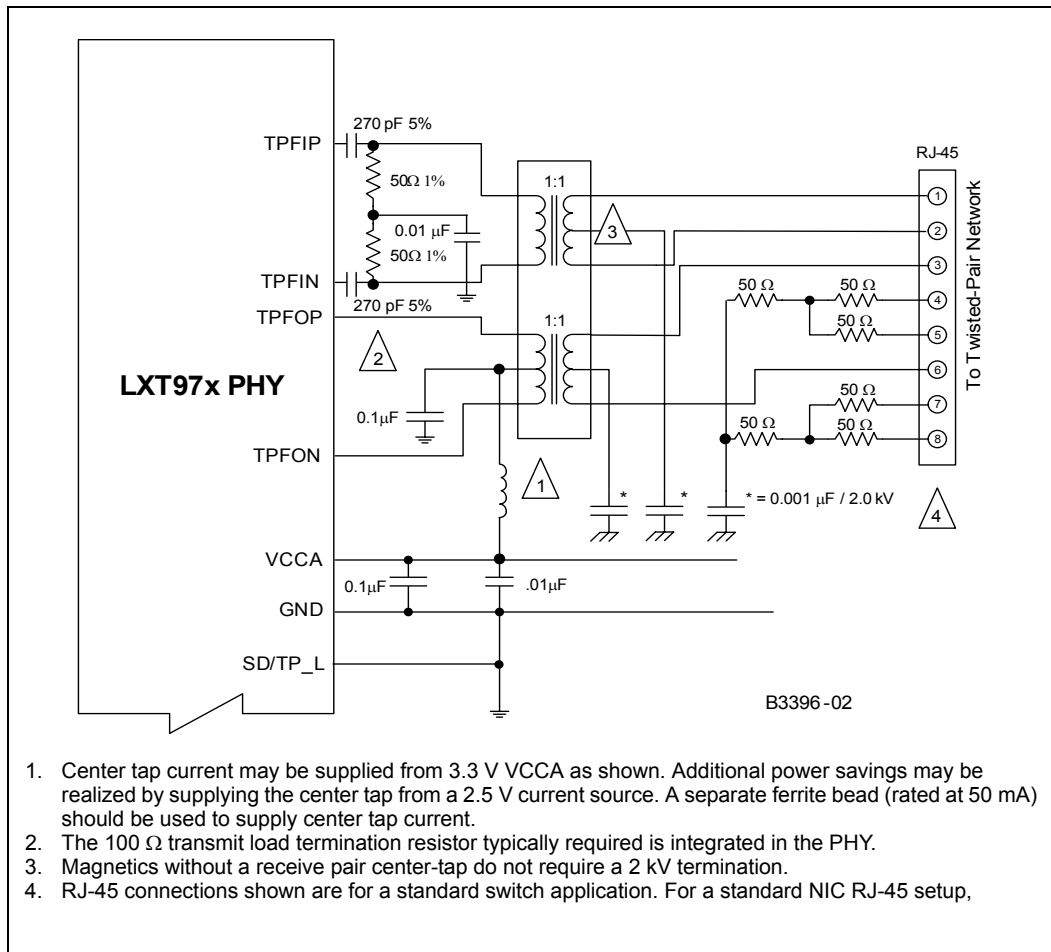

Figure 22 shows the LXT971A PHY in a typical twisted-pair interface, with the RJ-45 connections configured for a NIC application.

Figure 23 Typical Twisted-Pair Interface - NIC

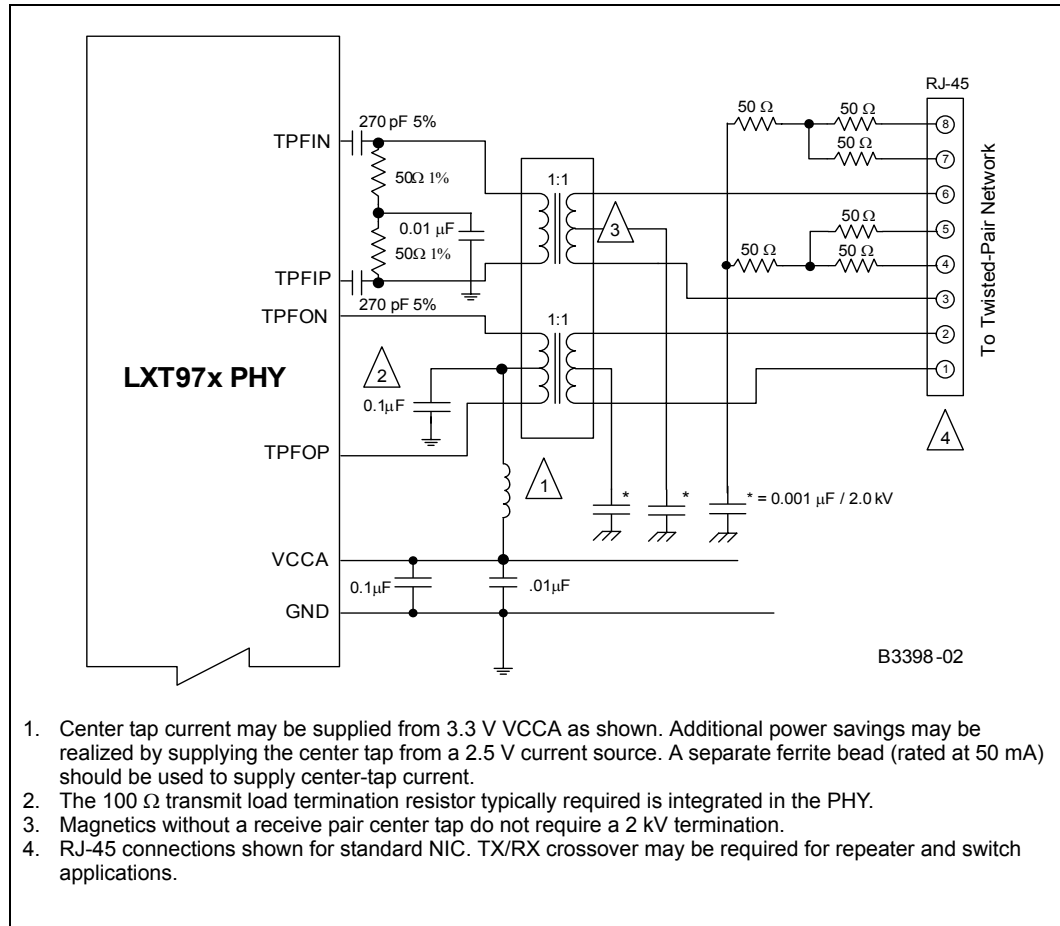
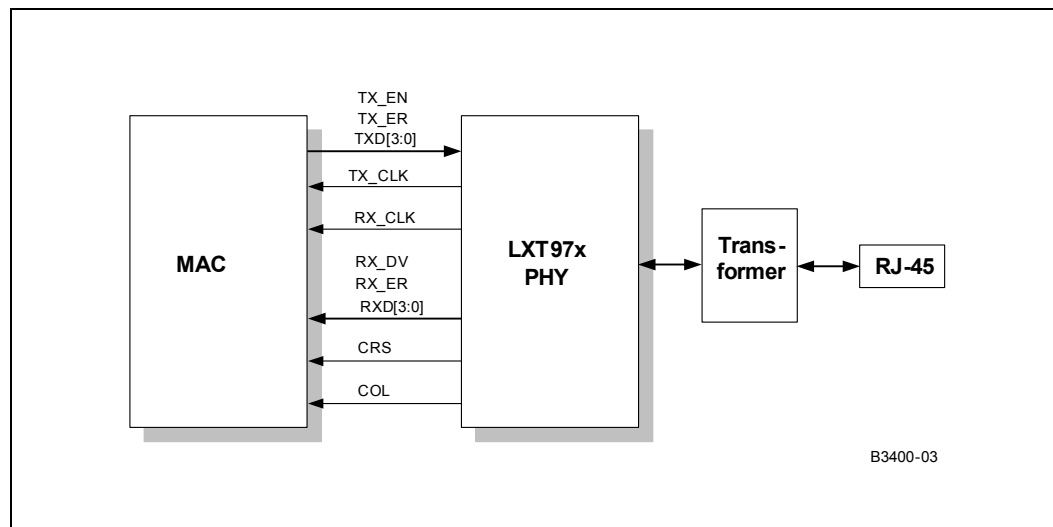

Figure 24 show a typical media independent interface (MII) for the LXT971A PHY.

Figure 24 Typical Media Independent Interface



6.3 Fiber Interface

The fiber interface consists of an LVPECL transmit and receive pair to an external fiber-optic PHY. Both 3.3 V fiber-optic PHYs and 5 V fiber-optic PHYs can be used with the LXT971A PHY. For details on fiber interface designs and recommendations for Cortina PHYs, see the document on 100BASE-FX fiber optics listed in [Section 1.2, Related Documents](#).

As shown in [Figure 25](#), the following should occur in 3.3 V fiber PHY applications:

- The transmit pair should be DC-coupled with the 50 Ω /16 Ω pull-up combination.
- The transmit pair should have a 2.74 k Ω pull-down resistor to prevent PHY-to-fiber PHY crosstalk amplification in power-down, loopback, and reset states. (See the fiber interface application note.)
- The receive pair should be DC-coupled with an emitter current path for the fiber PHY.
- The signal detect pin should be DC-coupled with an emitter current path for the fiber PHY.

[Figure 25](#) shows a typical example of an interface between the LXT971A PHY and a 3.3 V fiber PHY.

Figure 25 Typical Interface - LXT971A PHY to 3.3 V Fiber PHY

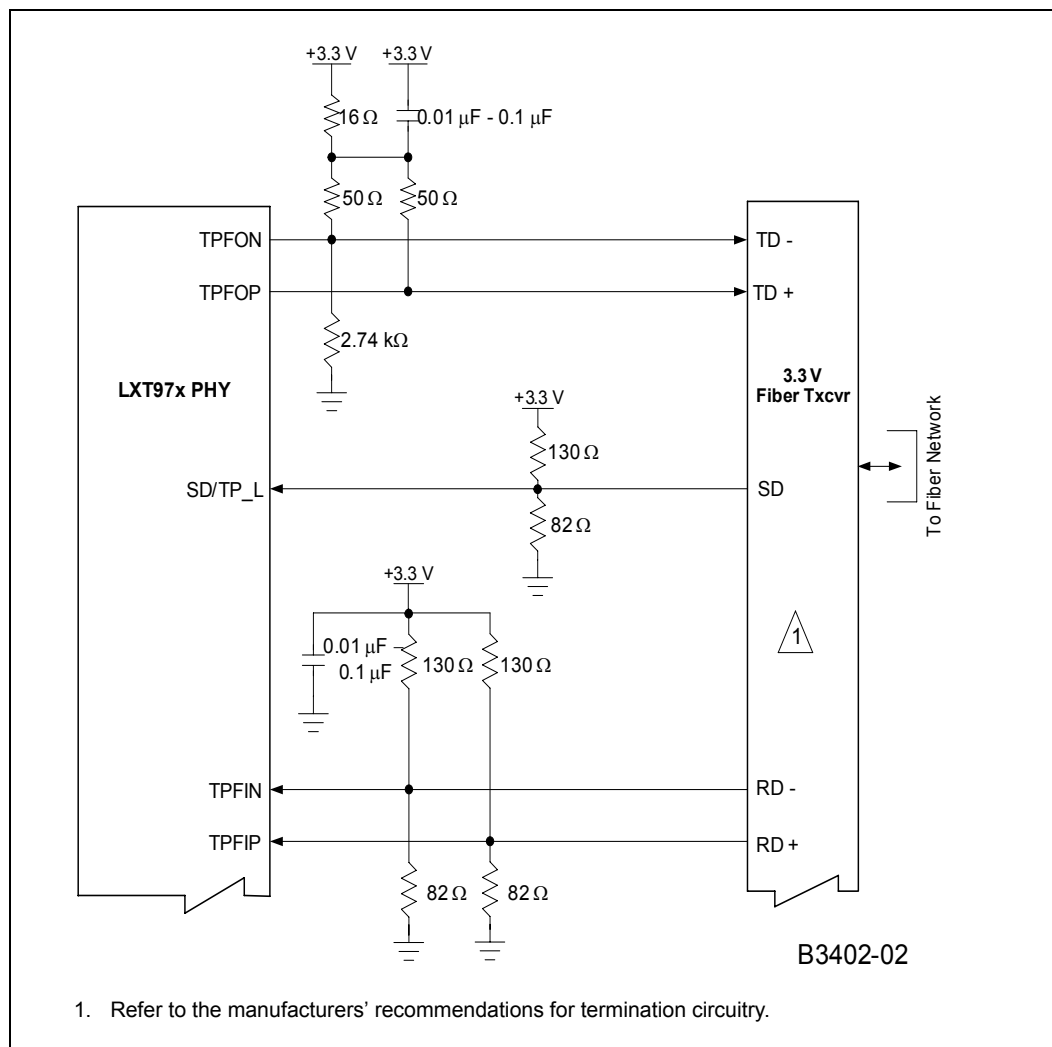

The following occurs in 5 V fiber PHY applications as shown in [Figure 26](#):

- The transmit pair should be AC-coupled and re-biased to 5 V PECL input levels.
- The transmit pair should contain a balance offset in the bias resistors to prevent PHY-to-fiber PHY crosstalk amplification in power-down, loopback, and reset states. (See the fiber interface application note.)
- The receive pair should be AC-coupled with an emitter current path for the fiber PHY and re-biased to 3.3 V LVPECL input levels.
- The signal detect pin on a 5 V fiber PHY interface should use the logic translator circuitry as shown in [Figure 26](#).

[Figure 26](#) shows a typical example of an interface between the LXT971A PHY and a 5 V fiber PHY.

Figure 26 Typical Interface LXT971A PHY to 5 V Fiber PHY

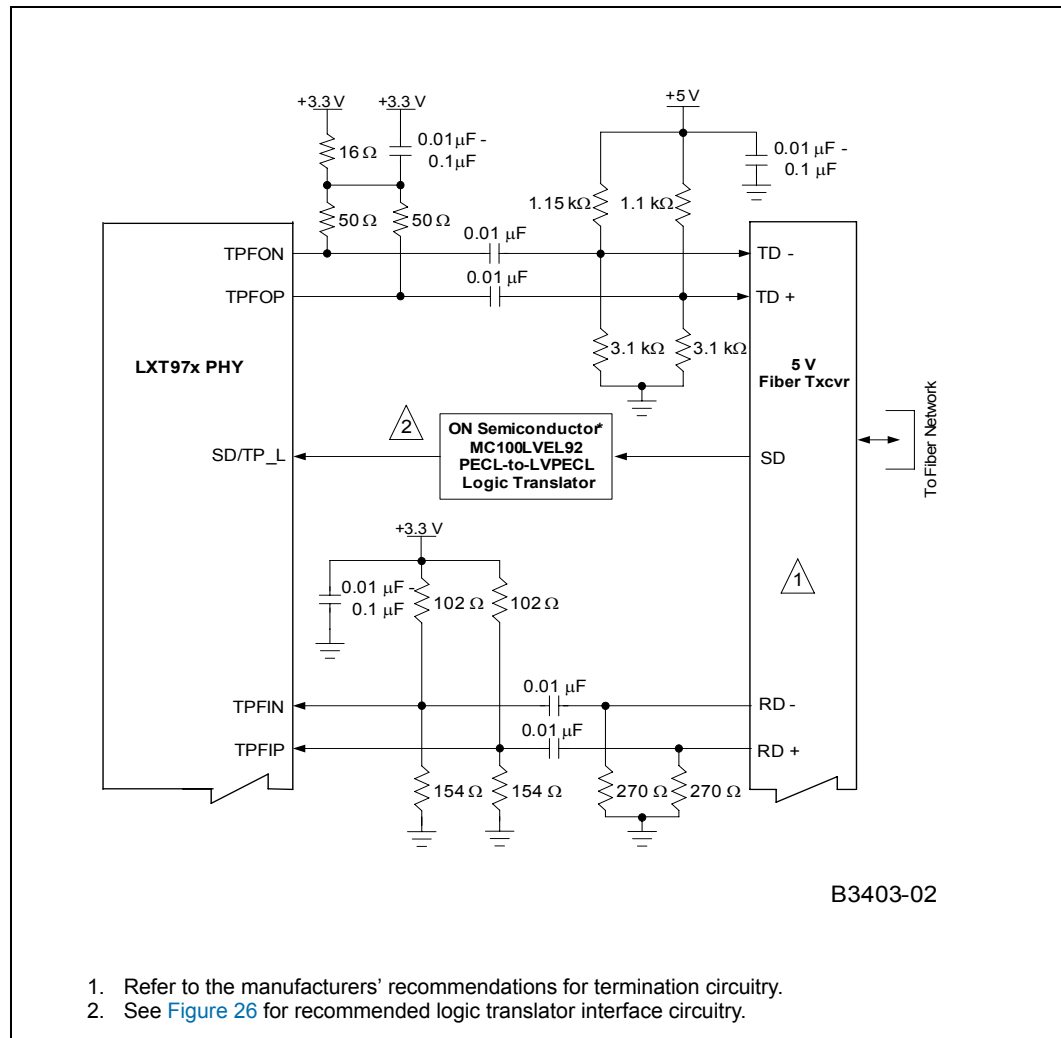
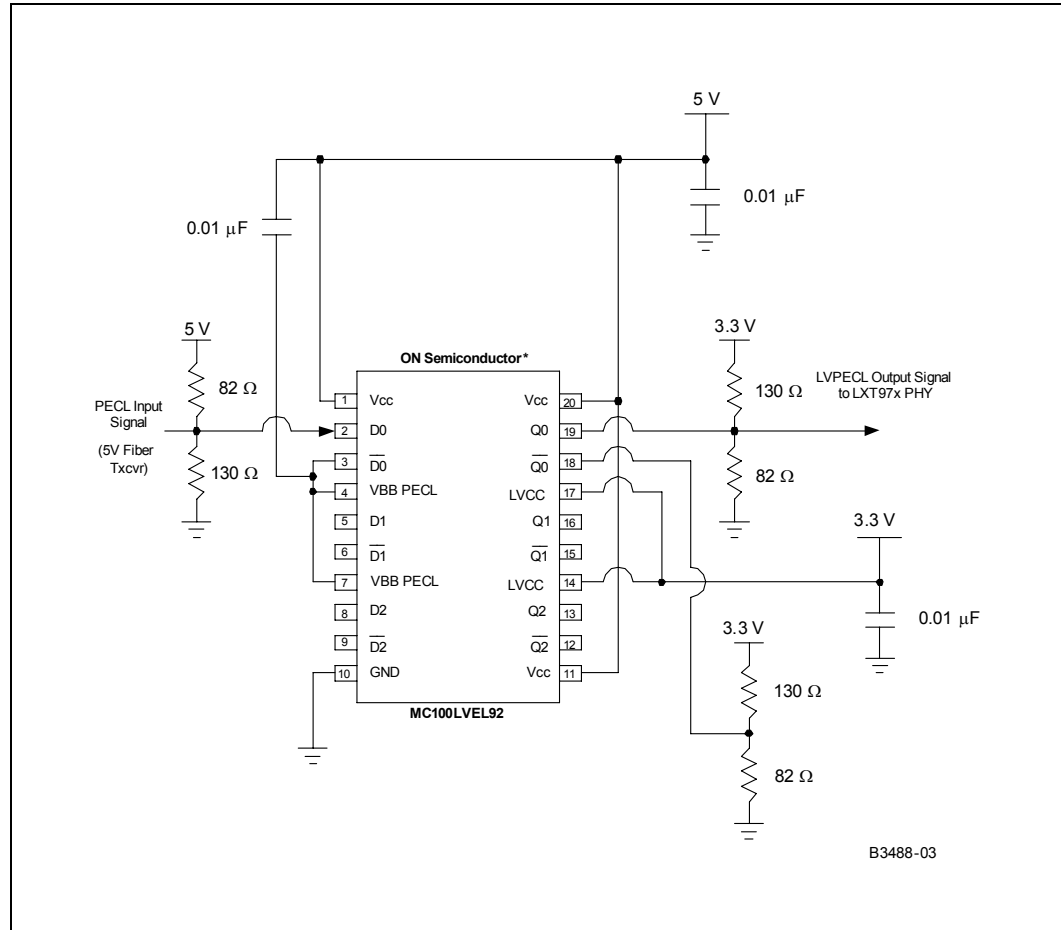

Figure 27 (a close-up view of Figure 26) shows typical interface between the LXT971A PHY and a PECL-to-PECL logic translator.

Figure 27 Typical Interface - LXT971A PHY to Triple PECL-to-PECL Logic Translator



7.0 Electrical Specifications

This chapter includes test specifications for the LXT971A PHY. These specifications are guaranteed by test except where noted “by design”.

Caution: Exceeding the absolute maximum rating values may cause permanent damage. Functional operation under these conditions is not implied. Exposure to maximum rating conditions for extended periods may affect device reliability.

7.1 DC Electrical Parameters

See the following DC specifications:

- Table 21, *Absolute Maximum Ratings*, on page 61
- Table 22, *Recommended Operating Conditions*, on page 61
- Table 23, *Digital I/O Characteristics (Except for MII, XI/XO, and LED/CFG Pins)*, on page 62
- Table 24, *Digital I/O Characteristics¹ - MII Pins*, on page 62
- Table 25, *I/O Characteristics - REFCLK/XI and XO Pins*, on page 63
- Table 26, *I/O Characteristics - LED/CFG Pins*, on page 63
- Table 27, *I/O Characteristics – SD/TP_L Pin*, on page 63
- Table 28, *100BASE-TX PHY Characteristics*, on page 63
- Table 29, *100BASE-FX PHY Characteristics*, on page 64
- Table 30, *10BASE-T PHY Characteristics*, on page 64
- Table 31, *10BASE-T Link Integrity Timing Characteristics*, on page 65
- Table 32, *Thermal Characteristics*, on page 65

Table 21 Absolute Maximum Ratings

Parameter	Sym	Min	Max	Units
Supply Voltage	VCC	-0.3	4.0	V
Operating temperature (Commercial)	T _{OP} A	-15	+85	°C
Operating temperature (Extended)	T _{OP} A	-55	+100	°C
Storage Temperature	T _{ST}	-65	+150	°C

Table 22 Recommended Operating Conditions (Sheet 1 of 2)

Parameter	Sym	Min	Typ ¹	Max	Units
Recommended operating temperature (Commercial)	T _{OP} A	0	–	70	°C
Recommended operating temperature (Extended)	T _{OP} A	-40	–	85	°C
Recommended supply voltage ² - Analog and digital	V _{CCA} , V _{CCD}	3.14	3.3	3.45	V
1. Typical values are at 25 °C and are for design aid only, not guaranteed, and not subject to production testing. 2. Voltages are with respect to ground unless otherwise specified.					

Table 22 Recommended Operating Conditions (Sheet 2 of 2)

Parameter	Sym	Min	Typ ¹	Max	Units
Recommended supply voltage ² - I/O	Vccio	2.35	–	3.45	V
VCC current - 100 BASE-TX	Icc	–	92	110	mA
VCC current - 10 BASE-T	Icc	–	66	82	mA
VCC current - 100 BASE-FX	Icc	–	72	95	mA
Sleep Mode	Icc	–	40	45	mA
Hard Power Down	Icc	–	–	1	mA
Soft Power Down	Icc	–	51	–	mA
Auto-Negotiation	Icc	–	90	110	mA

1. Typical values are at 25 °C and are for design aid only, not guaranteed, and not subject to production testing.
 2. Voltages are with respect to ground unless otherwise specified.

Table 23 Digital I/O Characteristics (Except for MII, XI/XO, and LED/CFG Pins)

Parameter	Sym	Min	Typ ¹	Max	Units	Test Conditions
Input Low voltage	VIL	–	–	0.8	V	–
Input High voltage	VIH	2.0	–	–	V	–
Input current	Ii	-10	–	10	μA	0.0 < Vi < Vcc
Output Low voltage	VOL	–	–	0.4	V	IOl = 4 mA
Output High voltage	VOH	2.4	–	–	V	IOH = -4 mA

1. Typical values are at 25 °C and are for design aid only, not guaranteed, and not subject to production testing.

Table 24 Digital I/O Characteristics¹ - MII Pins

Parameter	Sym	Min	Typ ²	Max	Units	Test Conditions
Input Low voltage	VIL	–	–	0.8	V	–
Input High voltage	VIH	2.0	–	–	V	–
Input current	Ii	-10	–	10	μA	0.0 < Vi < VCCIO
Output Low voltage	VOL	–	–	0.4	V	IOl = 4 mA
Output High voltage	VOH	2.2	–	–	V	IOH = -4 mA, VCCIO = 3.3 V
	VOH	2.0	–	–	V	IOH = -4 mA, VCCIO = 2.5 V
Driver output resistance (Line driver output enabled)	Ro ³	–	100	–	Ω	VCCIO = 2.5 V
	Ro ³	–	100	–	Ω	VCCIO = 3.3 V

1. MII digital I/O pins are tolerant to 5 V inputs.
 2. Typical values are at 25 °C and are for design aid only, not guaranteed, and not subject to production testing.
 3. Parameter is guaranteed by design and not subject to production testing.

Table 25 I/O Characteristics - REFCLK/XI and XO Pins

Parameter	Symbol	Min	Typ ¹	Max	Units	Test Conditions
Input Low Voltage	V _{IL}	–	–	0.8	V	–
Input High Voltage	V _{IH}	2.0	–	–	V	–
Input Clock Frequency Tolerance ²	Δf	–	–	±100	ppm	–
Input Clock Duty Cycle ²	T _{dc}	35	–	65	%	–
Input Capacitance	C _{IN}	–	3.0	–	pF	–

1. Typical values are at 25 °C and are for design aid only, not guaranteed, and not subject to production testing.
 2. Parameter is guaranteed by design and not subject to production testing.

Table 26 I/O Characteristics - LED/CFG Pins

Parameter	Symbol	Min	Typ	Max	Units	Test Conditions
Input Low Voltage	V _{IL}	–	–	0.8	V	–
Input High Voltage	V _{IH}	2.0	–	–	V	–
Input Current	I _I	-10	–	10	μA	0 < V _I < V _{CCIO}
Output Low Voltage	V _{OL}	–	–	0.4	V	I _{OL} = 10 mA
Output High Voltage	V _{OH}	2.0	–	–	V	I _{OH} = -10 mA

Table 27 I/O Characteristics – SD/TP_L Pin

Parameter	Sym	Min	Typ ¹	Max	Units	Test Conditions
Reset and Power-Up States – FX/TP Mode Configuration						
Fiber Mode (register bit 16.0 = 1)	V _{FX}	600	1600-2400	–	mV	–
Twisted-Pair Mode (register bit 16.0 = 0)	V _{TP}	–	GND	500	mV	–
100BASE-FX Mode Normal Operation – SD Input from Fiber PHY						
Input Low Voltage	V _{IL}	1.49	1.6	1.83	V	V _{CCD} = 3.3 V
Input High Voltage	V _{IH}	2.14	2.4	2.42	V	V _{CCD} = 3.3 V

1. Typical values are for design aid only, not guaranteed, and not subject to production testing.

Table 28 100BASE-TX PHY Characteristics (Sheet 1 of 2)

Parameter	Symbol	Min	Typ ¹	Max	Units	Test Conditions
Peak differential output voltage	V _P	0.95	–	1.05	V	Note 2
Signal amplitude symmetry	V _{SS}	98	–	102	%	Note 2
Signal rise/fall time	TR _F	3.0	–	5.0	ns	Note 2
Rise/fall time symmetry	TR _{FS}	–	–	0.5	ns	Note 2

1. Typical values are at 25 °C and are for design aid only, not guaranteed, and not subject to production testing.
 2. Measured at the line side of the transformer, line replaced by 100 Ω(+/-1%) resistor.

Table 28 100BASE-TX PHY Characteristics (Sheet 2 of 2)

Parameter	Symbol	Min	Typ ¹	Max	Units	Test Conditions
Duty cycle distortion	DCD	35	50	65	%	Offset from 16 ns pulse width at 50% of pulse peak
Overshoot/Undershoot	VOS	–	–	5	%	–
Jitter (measured differentially)	–	–	–	1.4	ns	–
1. Typical values are at 25 °C and are for design aid only, not guaranteed, and not subject to production testing. 2. Measured at the line side of the transformer, line replaced by 100 Ω(+/-1%) resistor.						

Table 29 100BASE-FX PHY Characteristics

Parameter	Symbol	Min	Typ ¹	Max	Units	Test Conditions
Transmitter						
Peak differential output voltage (single ended)	VOP	0.6	–	1.5	V	–
Signal rise/fall time	TRF	–	–	1.9	ns	10 <-> 90% 2.0 pF load
Jitter (measured differentially)	–	–	–	1.3	ns	–
Receiver						
Peak differential input voltage	VIP	0.55	–	1.5	V	–
Common mode input range	VCMIR	–	–	VCC - 0.7	V	–
1. Typical values are at 25 °C and are for design aid only, not guaranteed, and not subject to production testing.						

Table 30 10BASE-T PHY Characteristics

Parameter	Symbol	Min	Typ	Max	Units	Test Conditions
Transmitter						
Peak differential output voltage	VOP	2.2	2.5	2.8	V	With transformer, line replaced by 100 Ω resistor
Transition timing jitter added by the MAU and PLS sections	–	0	2	11	ns	After line model specified by IEEE 802.3 for 10BASE-T MAU
Receiver						
Receive Input Impedance	ZIN	–	–	22	kΩ	–
Differential Squelch Threshold	VDS	300	420	585	mV	–

Table 31 10BASE-T Link Integrity Timing Characteristics

Parameter	Symbol	Min	Typ	Max	Units	Test Conditions
Time Link Loss Receive	TLL	50	–	150	ms	–
Link Pulse	TLP	2	–	7	Link Pulses	–
Link Min Receive Timer	TLR MIN	2	–	7	ms	–
Link Max Receive Timer	TLR MAX	50	–	150	ms	–
Link Transmit Period	Tlt	8	–	24	ms	–
Link Pulse Width	Tlpw	60	–	150	ns	–

1. Typical values are at 25 °C and are for design aid only, not guaranteed, and not subject to production testing.

Table 32 Thermal Characteristics

Parameter	Value		
	LXT971A	LXT971ALE	LXT971ABE
Package	1 0x 10 x1.4 64 LD LQFP	10 x 10 x 1.4 64 LQFP	7 x 7 x .96 64 BGA-CSP
Theta-JA	58 C/W	56 C/W	42 C/W
Theta-JC	27 C/W	25 C/W	20 C/W
Psi - JT	3.4 C/W	3.0 C/W	–

7.2 AC Timing Diagrams and Parameters

See the following timing diagrams and AC parameters:

- Figure 28, *100BASE-TX Receive Timing - 4B Mode*, on page 66
- Figure 29, *100BASE-TX Transmit Timing - 4B Mode*, on page 67
- Figure 30, *100BASE-FX Receive Timing*, on page 68
- Figure 31, *100BASE-FX Transmit Timing*, on page 69
- Figure 32, *10BASE-T Receive Timing*, on page 70
- Figure 33, *10BASE-T Receive Timing*, on page 70
- Figure 35, *10BASE-T Jabber and Unjabber Timing*, on page 73
- Figure 36, *10BASE-T SQE (Heartbeat) Timing*, on page 73
- Figure 37, *Auto-Negotiation and Fast Link Pulse Timing*, on page 74
- Figure 38, *Fast Link Pulse Timing*, on page 74
- Figure 39, *MDIO Input Timing*, on page 75
- Figure 40, *MDIO Output Timing*, on page 75
- Figure 41, *Power-Up Timing*, on page 76
- Figure 42, *RESET_L Pulse Width and Recovery Timing*, on page 76

Figure 28 100BASE-TX Receive Timing - 4B Mode

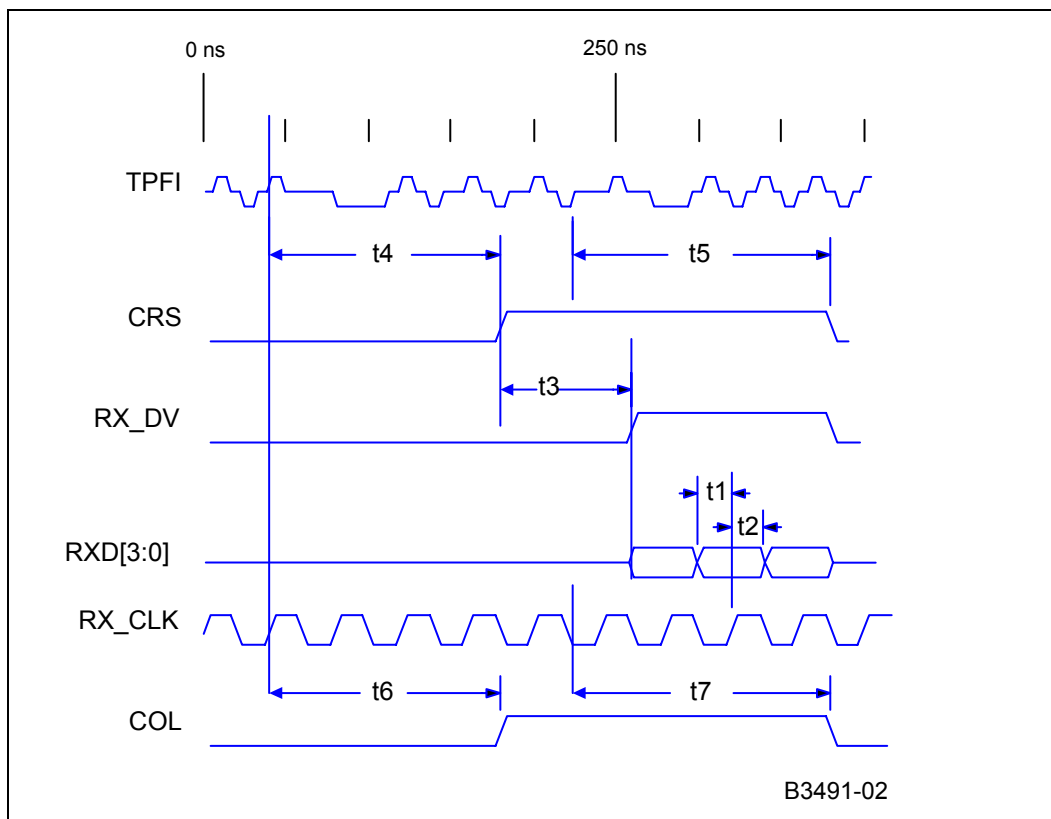

Table 33 100BASE-TX Receive Timing Parameters - 4B Mode

Parameter	Sym	Min	Typ ¹	Max	Units ²	Test Conditions
RXD[3:0], RX_DV, RX_ER ³ setup to RX_CLK High	t1	10	–	–	ns	–
RXD[3:0], RX_DV, RX_ER hold from RX_CLK High	t2	10	–	–	ns	–
CRS asserted to RXD[3:0], RX_DV	t3	3	–	5	BT	–
Receive start of “J” to CRS asserted	t4	12	–	16	BT	–
Receive start of “T” to CRS de-asserted	t5	10	–	17	BT	–
Receive start of “J” to COL asserted	t6	16	–	22	BT	–
Receive start of “T” to COL de-asserted	t7	17	–	20	BT	–

1. Typical values are at 25 °C and are for design aid only, not guaranteed, and not subject to production testing.
 2. BT (Bit Time) is the duration of one bit as transferred to and from the Mac and is the reciprocal of the bit rate. 100BASE-T bit time = 10⁻⁸ s or 10 ns.
 3. RX_ER is not shown in the figure.

Figure 29 100BASE-TX Transmit Timing - 4B Mode

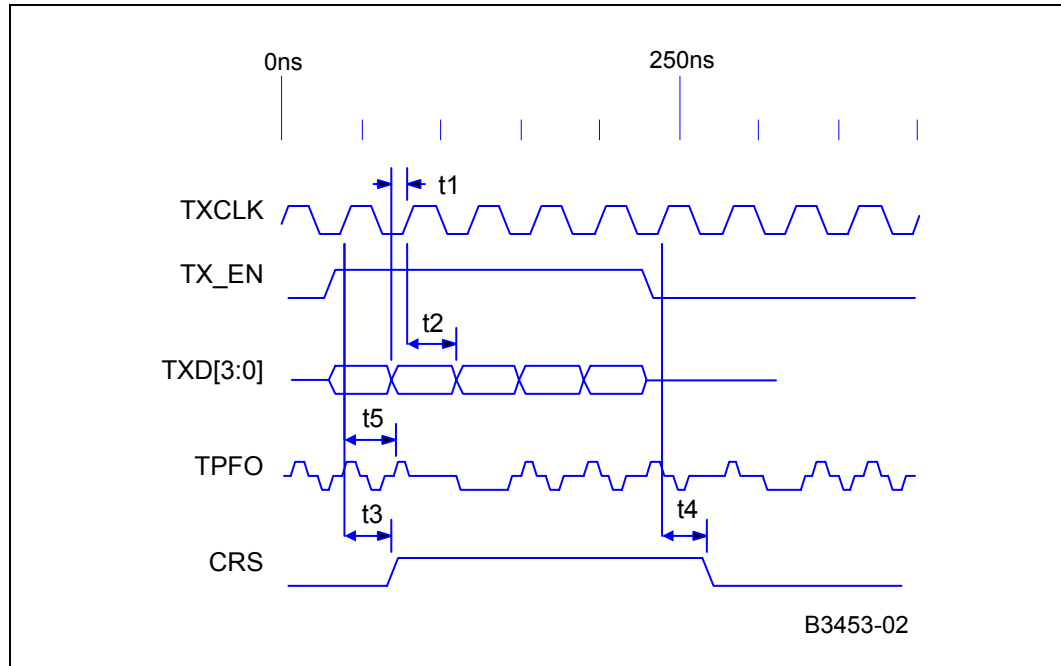

Table 34 100BASE-TX Transmit Timing Parameters - 4B Mode

Parameter	Symbol	Min	Typ ¹	Max	Units ²	Test Conditions
TXD[3:0], TX_EN, TX_ER ³ setup to TX_CLK High	t1	12	–	–	ns	–
TXD[3:0], TX_EN, TX_ER hold from TX_CLK High	t2	0	–	–	ns	–
TX_EN sampled to CRS asserted	t3	20	–	24	BT	–
TX_EN sampled to CRS de-asserted	t4	24	–	28	BT	–
TX_EN sampled to TPFO out (Tx latency)	t5	5.3	–	5.7	BT	–

1. Typical values are at 25 °C and are for design aid only, not guaranteed, and not subject to production testing.
 2. BT (Bit Time) is the duration of one bit as transferred to and from the MAC and is the reciprocal of the bit rate. 100BASE-T bit time = 10⁻⁸ s or 10 ns.
 3. TX_ER is not shown in the figure.

Figure 30 100BASE-FX Receive Timing

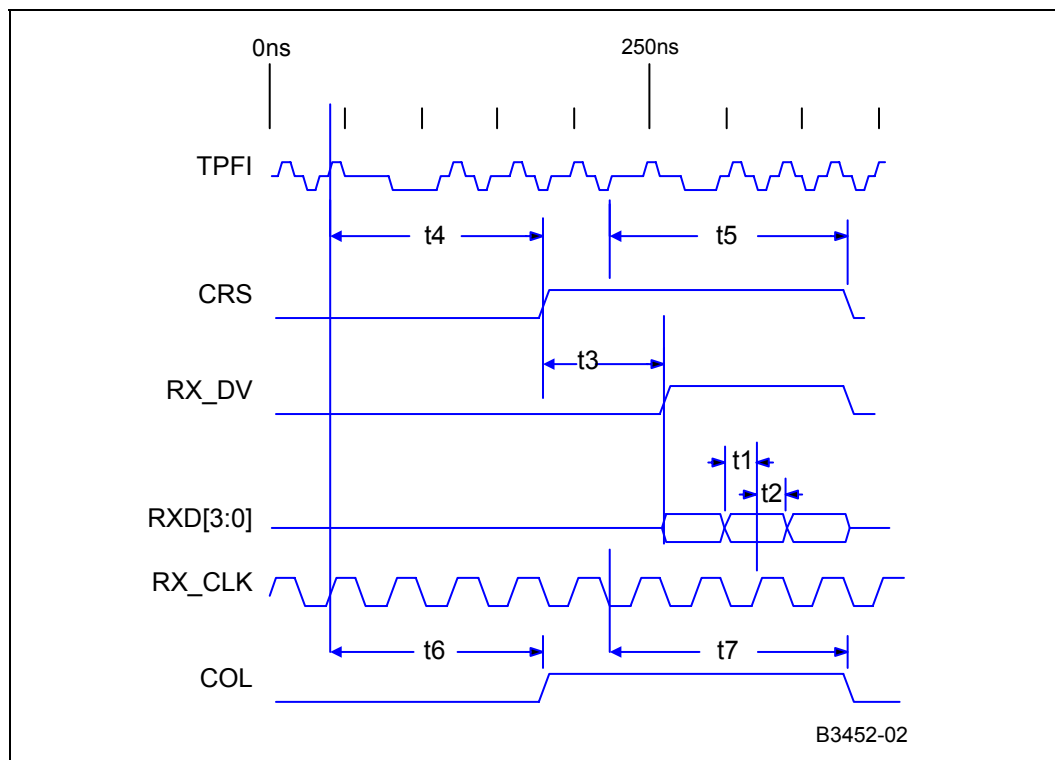

Table 35 100BASE-FX Receive Timing Parameters

Parameter	Sym	Min	Typ ¹	Max	Units ²	Test Conditions
RXD[3:0], RX_DV, set up to RX_CLK High	t1	10	–	–	ns	–
RXD[3:0], RX_DV, RX_ER ³ hold from RX_CLK High	t2	10	–	–	ns	–
CRS asserted to RXD[3:0], RX_DV	t3	3	–	5	BT	–
Receive start of "J" to CRS asserted	t4	12	–	16	BT	–
Receive start of "T" to CRS de-asserted	t5	16	–	22	BT	–
Receive start of "J" to COL asserted	t6	10	–	15	BT	–
Receive start of "T" to COL de-asserted	t7	14	–	18	BT	–

1. Typical values are at 25 °C and are for design aid only, not guaranteed, and not subject to production testing.
 2. BT (Bit Time) is the duration of one bit as transferred to and from the MAC and is the reciprocal of the bit rate. 100BASE-T bit time = 10⁻⁸ s or 10 ns.
 3. The RX_ER signal is not shown in the figure.

Figure 31 100BASE-FX Transmit Timing

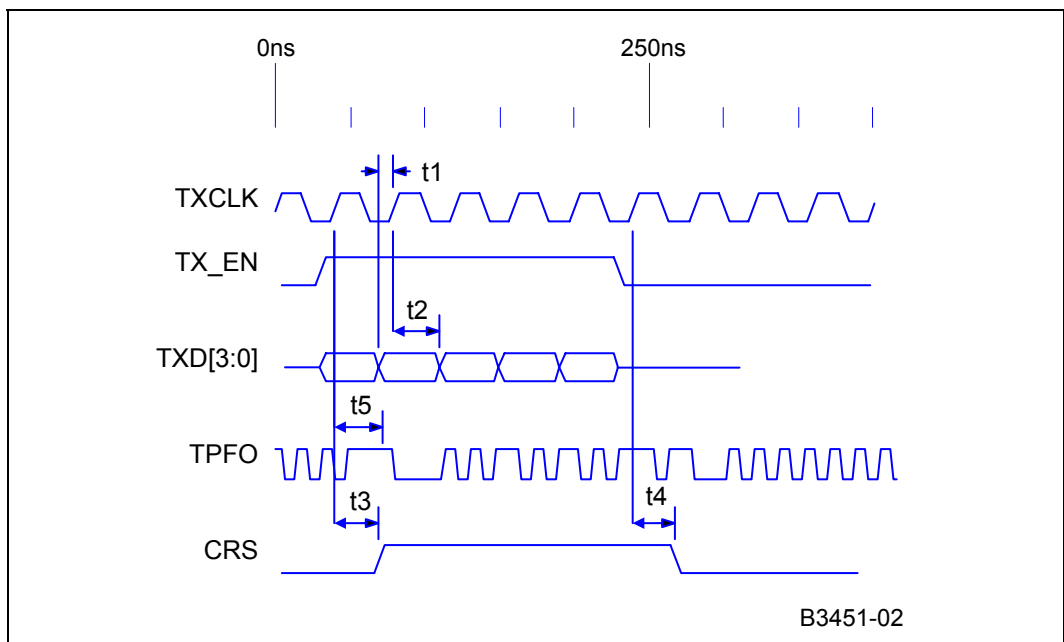

Table 36 100BASE-FX Transmit Timing Parameters

Parameter	Symbol	Min	Typ ¹	Max	Units ²	Test Conditions
TXD[3:0], TX_EN, TX_ER ³ setup to TX_CLK High	t1	12	–	–	ns	–
TXD[3:0], TX_EN, TX_ER hold from TX_CLK High	t2	0	–	–	ns	–
TX_EN sampled to CRS asserted	t3	17	–	20	BT	–
TX_EN sampled to CRS de-asserted	t4	22	–	24	BT	–
TX_EN sampled to TPFO out (Tx latency)	t5	5	–	5.3	BT	–

1. Typical values are at 25 °C and are for design aid only, not guaranteed, and not subject to production testing.
 2. BT (Bit Time) is the duration of one bit as transferred to and from the MAC and is the reciprocal of the bit rate. 100BASE-T bit time = 10⁻⁸ s or 10 ns.
 3. The TX_ER signal is not shown in the figure.

Figure 32 10BASE-T Receive Timing

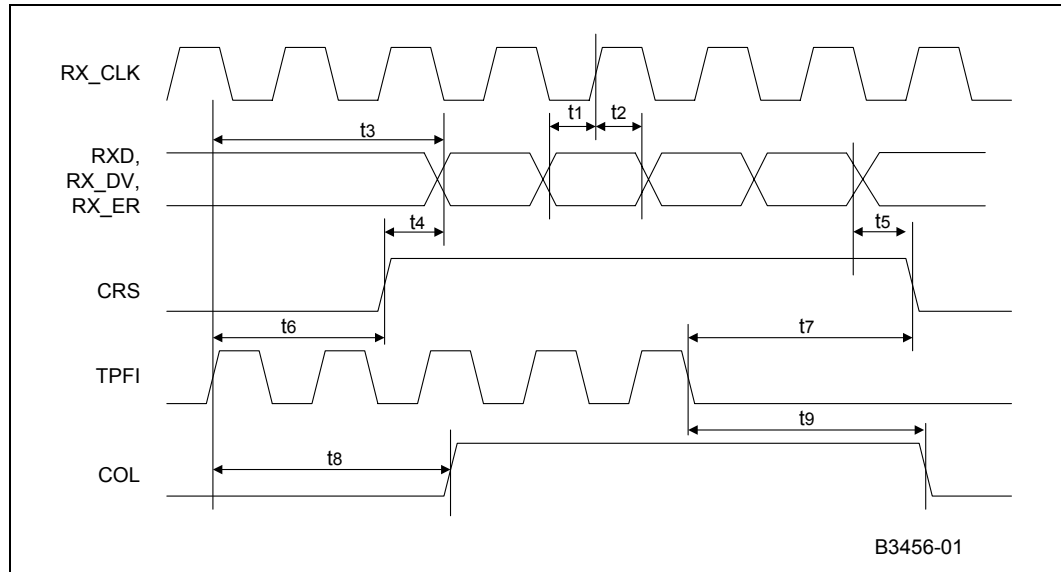

Figure 33 10BASE-T Receive Timing

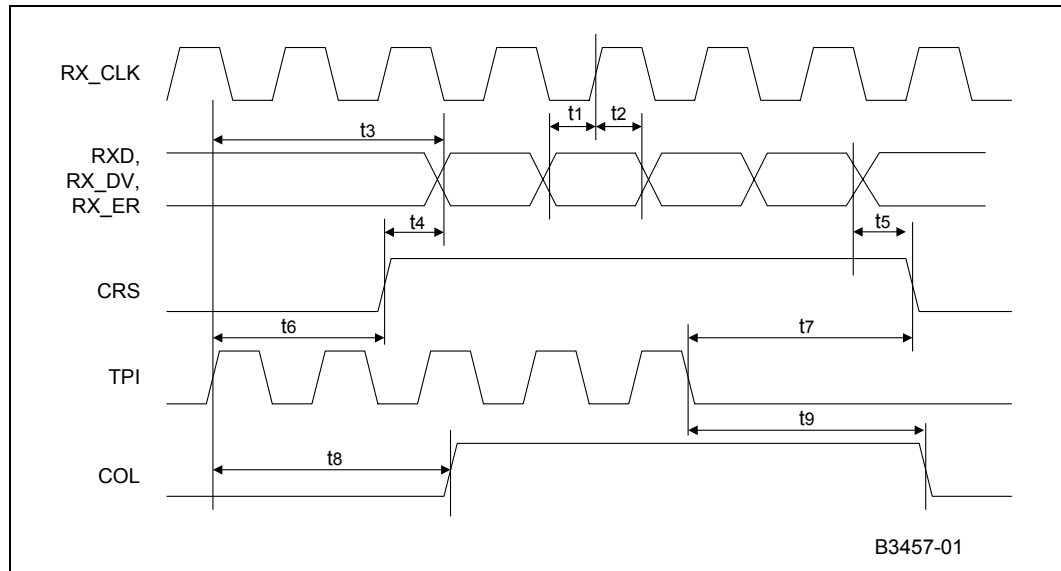

Table 37 10BASE-T Receive Timing Parameters

Parameter	Sym	Min	Typ ¹	Max	Units ²	Test Conditions
RXD, RX_DV, RX_ER Setup to RX_CLK High	t1	10	–	–	ns	–
RXD, RX_DV, RX_ER Hold from RX_CLK High	t2	10	–	–	ns	–
TPFIP/N in to RXD out (Rx latency)	t3	4.2	–	6.6	BT	–
CRS asserted to RXD, RX_DV, RX_ER asserted	t4	5	–	32	BT	–
RXD, RX_DV, RX_ER de-asserted to CRS de-asserted	t5	0.3	–	0.5	BT	–
TPFI in to CRS asserted	t6	2	–	28	BT	–
TPFI quiet to CRS de-asserted	t7	6	–	10	BT	–
TPFI in to COL asserted	t8	1	–	31	BT	–
TPFI quiet to COL de-asserted	t9	5	–	10	BT	–
1. Typical values are at 25 °C and are for design aid only, not guaranteed, and not subject to production testing. 2. BT (Bit Time) is the duration of one bit as transferred to and from the MAC and is the reciprocal of the bit rate. 10BASE-T bit time = 10 ⁻⁷ s or 100 ns.						

Figure 34 10BASE-T Transmit Timing

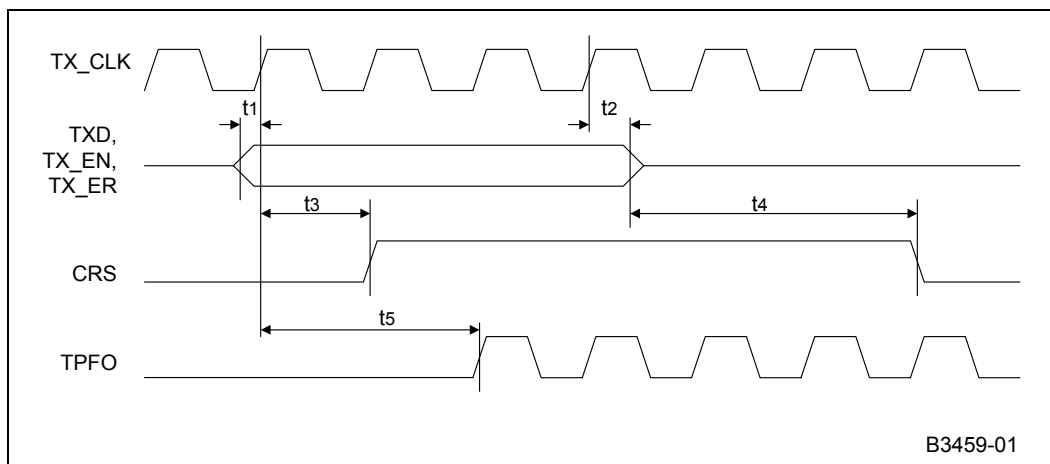

Table 38 10BASE-T Transmit Timing Parameters

Parameter	Symbol	Min	Typ ¹	Max	Units ²	Test Conditions
TXD, TX_EN, TX_ER setup to TX_CLK High	t1	10	–	–	ns	–
TXD, TX_EN, TX_ER hold from TX_CLK High	t2	0	–	–	ns	–
TX_EN sampled to CRS asserted	t3	–	2	–	BT	–
TX_EN sampled to CRS de-asserted	t4	–	1	–	BT	–
TX_EN sampled to TPFO out (Tx latency)	t5	–	72.5	–	BT	–

1. Typical values are at 25 °C and are for design aid only, not guaranteed, and not subject to production testing.
 2. BT (Bit Time) is the duration of one bit as transferred to and from the MAC and is the reciprocal of the bit rate. 10BASE-T bit time = 10⁻⁷ s or 100 ns.

Figure 35 10BASE-T Jabber and Unjabber Timing

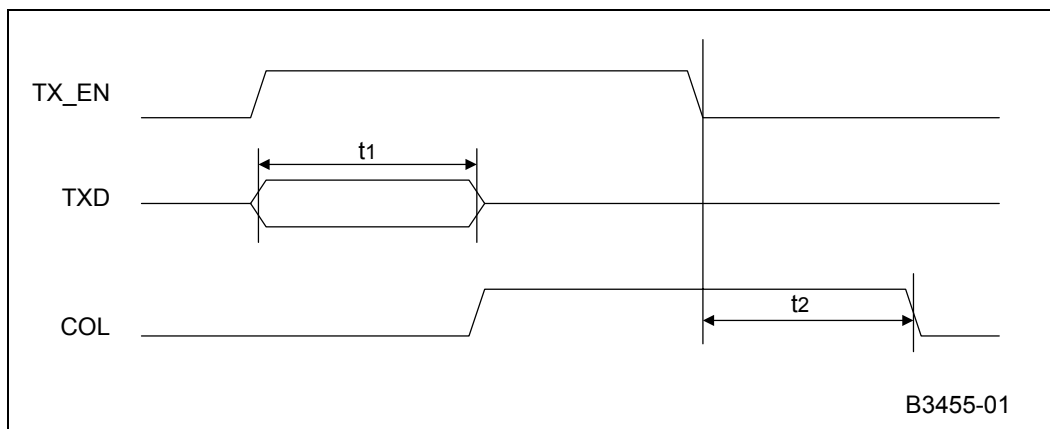

Table 39 10BASE-T Jabber and Unjabber Timing

Parameter	Symbol	Min	Typ ¹	Max	Units	Test Conditions
Maximum transmit time	t1	20	–	150	ms	–
Unjabber time	t2	250	–	750	ms	–

1. Typical values are at 25 °C and are for design aid only, not guaranteed, and not subject to production testing.

Figure 36 10BASE-T SQE (Heartbeat) Timing

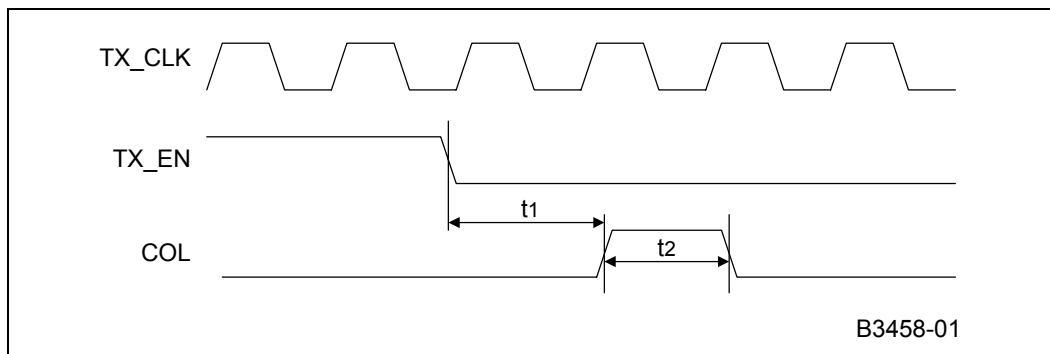

Table 40 PHY 10BASE-T SQE (Heartbeat) Timing

Parameter	Symbol	Min	Typ ¹	Max	Units	Test Conditions
COL (SQE) Delay after TX_EN off	t1	0.65	–	1.6	us	–
COL (SQE) Pulse duration	t2	0.5	–	1.5	us	–

1. Typical values are at 25 °C and are for design aid only, not guaranteed, and not subject to production testing.

Figure 37 Auto-Negotiation and Fast Link Pulse Timing

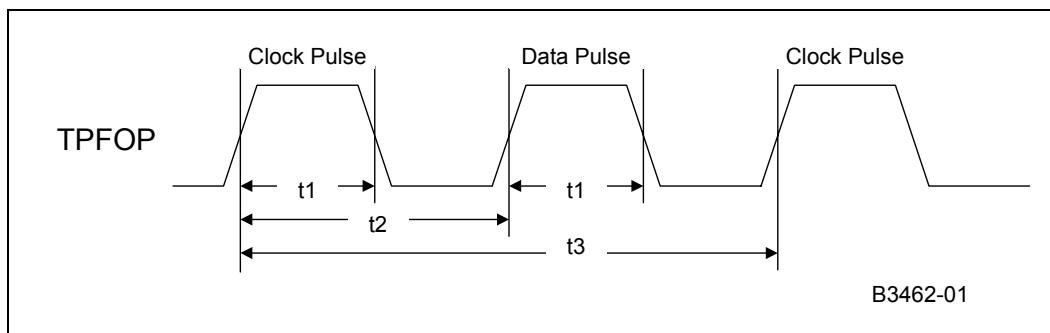

Figure 38 Fast Link Pulse Timing

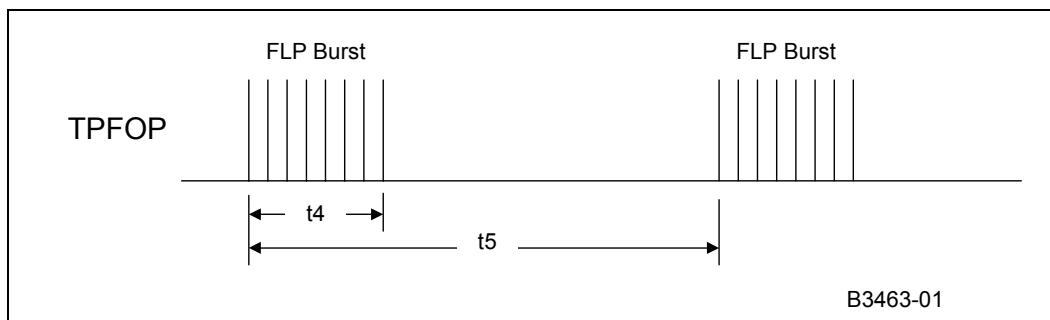

Table 41 Auto-Negotiation and Fast Link Pulse Timing Parameters

Parameter	Symbol	Min	Typ ¹	Max	Units	Test Conditions
Clock/Data pulse width	t1	–	100	–	ns	–
Clock pulse to Data pulse	t2	55.5	–	63.8	μs	–
Clock pulse to Clock pulse	t3	123	–	127	μs	–
FLP burst width	t4	–	2	–	ms	–
FLP burst to FLP burst	t5	8	12	24	ms	–
Clock/Data pulses per burst	–	17	–	33	Each clock pulse or data pulse	–

1. Typical values are at 25 °C and are for design aid only, not guaranteed, and not subject to production testing.

Figure 39 MDIO Input Timing

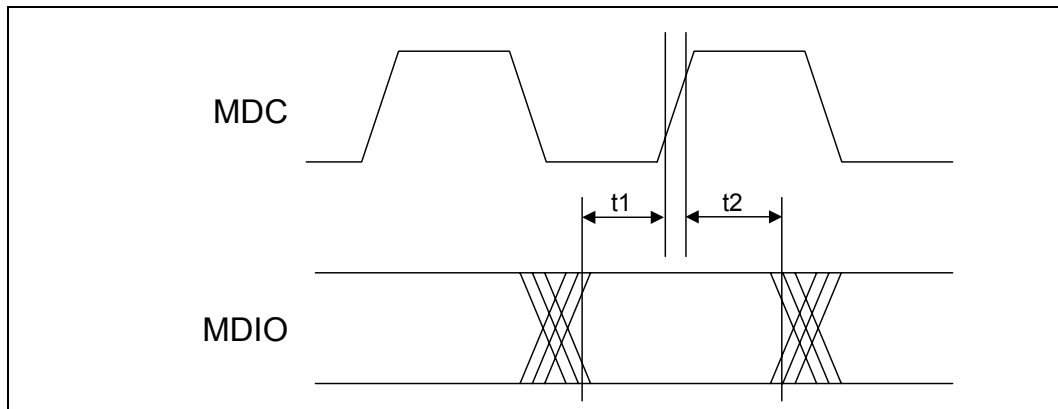

Figure 40 MDIO Output Timing

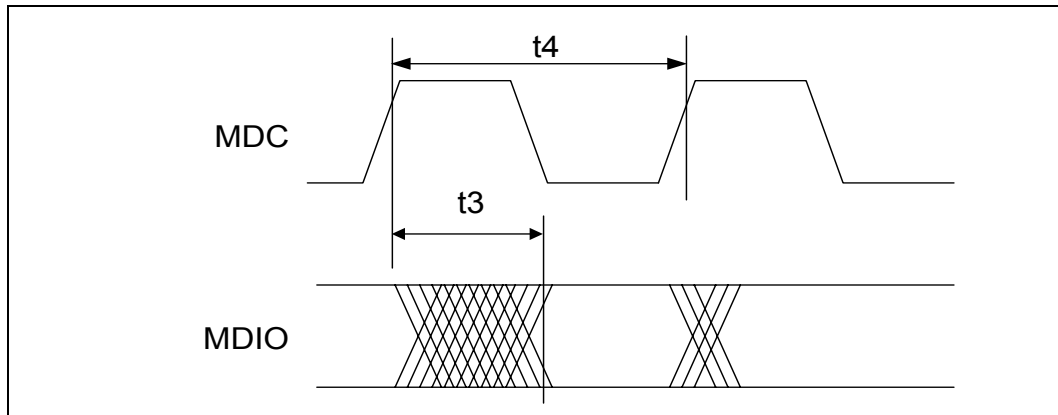

Table 42 MDIO Timing

Parameter	Symbol	Min	Typ ¹	Max	Units	Test Conditions
MDIO setup before MDC, sourced by STA	t1	10	–	–	ns	–
MDIO hold after MDC, sourced by STA	t2	5	–	–	ns	–
MDC to MDIO output delay, sourced by PHY	t3	–	–	150	ns	–
MDC period	t4	125	–	–	ns	MDC = 8 MHz

1. Typical values are at 25° C and are for design aid only, not guaranteed, and not subject to production testing.

Figure 41 Power-Up Timing

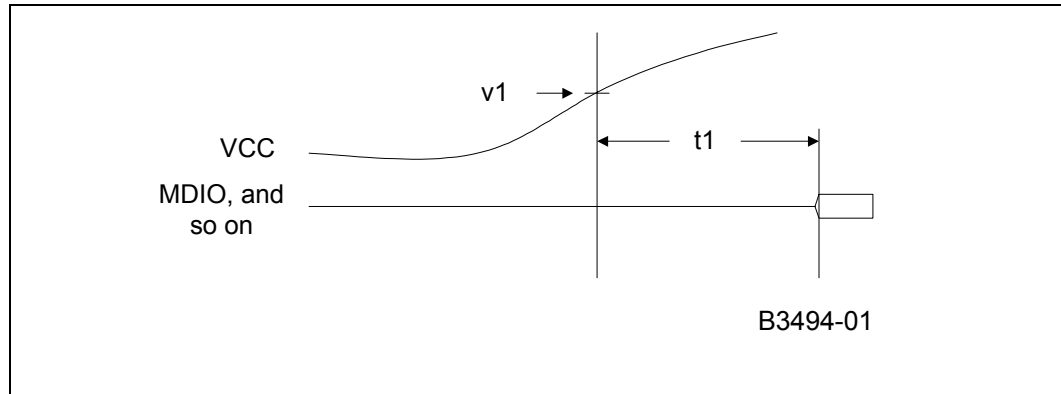

Table 43 Power-Up Timing

Parameter	Symbol	Min	Typ ¹	Max	Units	Test Conditions
Voltage threshold	v1	–	2.9	–	V	–
Power Up delay ²	t1	–	–	300	μs	–

1. Typical values are at 25° C and are for design aid only, not guaranteed, and not subject to production testing.
 2. Power-up delay is specified as a maximum value because it refers to the PHY guaranteed performance. The PHY comes out of reset after a delay of no more than 300 μs. System designers should consider this value as a minimum value. After threshold v1 is reached, the MAC should delay no less than 300 μs before accessing the MDIO port.

Figure 42 RESET_L Pulse Width and Recovery Timing

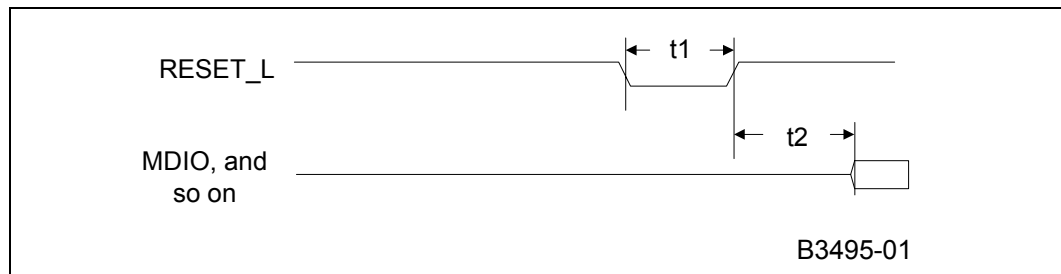

Table 44 **RESET_L Pulse Width and Recovery Timing**

Parameter	Symbol	Min	Typ ¹	Max	Units	Test Conditions
RESET_L pulse width	t1	10	–	–	ns	–
RESET_L recovery delay ²	t2	–		300	μs	–
1. Typical values are at 25° C and are for design aid only, not guaranteed, and not subject to production testing. 2. Reset Recovery Delay is specified as a maximum value because it refers to the PHY guaranteed performance. The PHY comes out of reset after a delay of no more than 300 μs. System designers should consider this value as a minimum value. After de-asserting RESET_L, the MAC should delay no less than 300 μs before accessing the MDIO port.						

8.0 Register Definitions - IEEE Base Registers

This chapter includes definitions for the IEEE base registers used by the LXT971A PHY. [Section 9.0, Register Definitions - Product-Specific Registers](#) includes definitions of additional product-specific LXT971A PHY registers, which are defined in accordance with the IEEE 802.3 standard for adding unique device functions.

The LXT971A PHY register set has multiple 16-bit registers.

- [Table 45](#) is a register set listing of the IEEE base registers.
- [Table 46](#) through [Table 54](#) provide bit descriptions of the base registers (address 0 through 8), which are defined in accordance with the “Reconciliation Sublayer and Media Independent Interface” and “Physical Layer Link Signaling for 10/100 Mbps Auto-Negotiation” sections of the IEEE 802.3 standard.

Table 45 Register Set for IEEE Base Registers

Address	Register Name	Bit Assignments
0	Control Register	See Table 46 on page 79
1	Status Register #1	See Table 47 on page 80
2	PHY Identification Register 1	See Table 48 on page 81
3	PHY Identification Register 2	See Table 49 on page 81
4	Auto-Negotiation Advertisement Register	See Table 50 on page 82
5	Auto-Negotiation Link Partner Base Page Ability Register	See Table 51 on page 83
6	Auto-Negotiation Expansion Register	See Table 52 on page 84
7	Auto-Negotiation Next Page Transmit Register	See Table 53 on page 84
8	Auto-Negotiation Link Partner Next Page Receive Register	See Table 54 on page 85
9	1000BASE-T/100BASE-T2 Control Register	Not Implemented
10	1000BASE-T/100BASE-T2 Status Register	Not Implemented
11 to 14	Reserved	Not Implemented
15	Extended Status Register	Not Implemented

Table 46 Control Register - Address 0, Hex 0

Bit	Name	Description			Type ¹	Default
0.15	Reset	0 = Normal operation 1 = PHY reset			R/W SC	0
0.14	Loopback	0 = Disable loopback mode 1 = Enable loopback mode			R/W	0
0.13	Speed Selection	0.6	0.13	Speed Selected	R/W	Note 2
		0	0	10 Mbps		
		0	1	100 Mbps		
		1	0	1000 Mbps (not supported)		
1	1	Reserved				
0.12	Auto-Negotiation Enable	0 = Disable auto-negotiation process 1 = Enable auto-negotiation process			R/W	Note 2
0.11	Power-Down	0 = Normal operation 1 = Power-down			R/W	0
0.10	Isolate	0 = Normal operation 1 = Electrically isolate PHY from MII			R/W	0
0.9	Restart Auto-Negotiation	0 = Normal operation 1 = Restart auto-negotiation process			R/W SC	0
0.8	Duplex Mode	0 = Half-duplex 1 = Full-duplex			R/W	Note 2
0.7	Collision Test	0 = Disable COL signal test 1 = Enable COL signal test			R/W	0
0.6	Speed Selection	0.6	0.13	Speed Selected	R/W	0
		0	0	10 Mbps		
		0	1	100 Mbps		
		1	0	1000 Mbps (not supported)		
1	1	Reserved				
0.5:0	Reserved	Write as '0'. Ignore on Read.			R/W	00000

1. R/W = Read/Write
 SC = Self Clearing

2. Some bits have their default values determined at reset by hardware configuration pins. For default details for these bits, see [Section 5.4.4, Hardware Configuration Settings](#).

Table 47 MII Status Register #1 - Address 1, Hex 1

Bit	Name	Description	Type ¹	Default
1.15	100BASE-T4 Not Supported	0 = PHY not able to perform 100BASE-T4 1 = PHY able to perform 100BASE-T4	RO	0
1.14	100BASE-X Full-Duplex	0 = PHY not able to perform full-duplex 100BASE-X 1 = PHY able to perform full-duplex 100BASE-X	RO	1
1.13	100BASE-X Half-Duplex	0 = PHY not able to perform half-duplex 100BASE-X 1 = PHY able to perform half-duplex 100BASE-X	RO	1
1.12	10 Mbps Full-Duplex	0 = PHY not able to operate at 10 Mbps full-duplex mode 1 = PHY able to operate at 10 Mbps in full-duplex mode	RO	1
1.11	10 Mbps Half-Duplex	0 = PHY not able to operate at 10 Mbps in half-duplex mode 1 = PHY able to operate at 10 Mbps in half-duplex mode	RO	1
1.10	100BASE-T2 Full-Duplex Not Supported	0 = PHY not able to perform full-duplex 100BASE-T2 1 = PHY able to perform full-duplex 100BASE-T2	RO	0
1.9	100BASE-T2 Half-Duplex Not Supported	0 = PHY not able to perform half-duplex 100BASE-T2 1 = PHY able to perform half-duplex 100BASE-T2	RO	0
1.8	Extended Status	0 = No extended status information in register 15 1 = Extended status information in register 15	RO	0
1.7	Reserved	Ignore when read.	RO	0
1.6	MF Preamble Suppression	0 = PHY cannot accept management frames with preamble suppressed 1 = PHY accepts management frames with preamble suppressed	RO	0
1.5	Auto-Negotiation complete	0 = Auto-negotiation not complete 1 = Auto-negotiation complete	RO	0
1.4	Remote Fault	0 = No remote fault condition detected 1 = Remote fault condition detected	RO/LH	0
1.3	Auto-Negotiation Ability	0 = PHY is not able to perform auto-negotiation 1 = PHY is able to perform auto-negotiation	RO	1
1.2	Link Status	0 = Link is down 1 = Link is up	RO/LL	0
1.1	Jabber Detect	0 = Jabber condition not detected 1 = Jabber condition detected	RO/LH	0
1.0	Extended Capability	0 = Basic register capabilities 1 = Extended register capabilities	RO	1
1. RO = Read Only LL = Latching Low LH = Latching High				

Table 48 PHY Identification Register 1 - Address 2, Hex 2

Bit	Name	Description	Type ¹	Default
Note: See Figure 43 for identifier bit mapping.				
2.15:0	PHY ID Number	The PHY identifier is composed of bits 3 through 18 of the Organizationally Unique Identifier (OUI).	RO	0013 hex
1. RO = Read Only				

Table 49 PHY Identification Register 2 - Address 3, Hex 3

Bit	Name	Description	Type ¹	Default
Note: See Figure 43 for identifier bit mapping.				
3.15:10	PHY ID number	The PHY identifier is composed of bits 19 through 24 of the OUI.	RO	011110
3.9:4	Manufacturer's model number	6 bits containing manufacturer's part number.	RO	001110
3.3:0	Manufacturer's revision number	4 bits containing manufacturer's revision number.	RO	For current revision ID information, see the Specification Update.
1. RO = Read Only				

Figure 43 PHY Identifier Bit Mapping

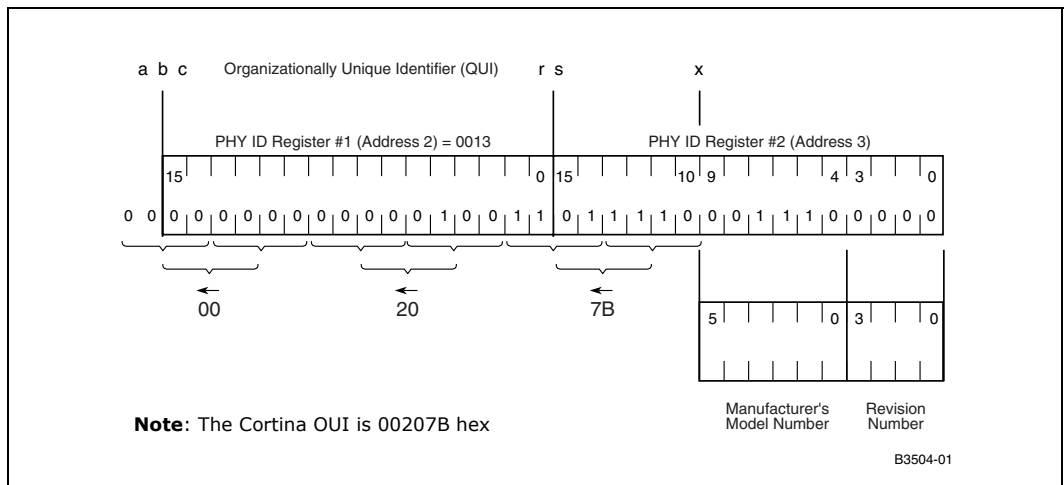

Table 50 Auto-Negotiation Advertisement Register - Address 4, Hex 4

Bit	Name	Description	Type ¹	Default
4.15	Next Page	0 = Port has no ability to send multiple pages. 1 = Port has ability to send multiple pages.	R/W	0
4.14	Reserved	Ignore when read.	RO	0
4.13	Remote Fault	0 = No remote fault. 1 = Remote fault.	R/W	0
4.12	Reserved	Write as '0'. Ignore on Read.	R/W	0
4.11	Asymmetric Pause	Pause operation defined in IEEE 802.3 Standard, Clause 40 and 27	R/W	0
4.10	Pause	0 = Pause operation disabled. 1 = Pause operation enabled for full-duplex link.	R/W	Note 2
4.9	100BASE-T4	0 = 100BASE-T4 capability is not available. 1 = 100BASE-T4 capability is available. Note: The LXT971A PHY does not support 100BASE-T4 but allows this bit to be set to advertise in the auto-negotiation sequence for 100BASE-T4 operation. An external 100BASE-T4 PHY can be switched in if this capability is desired.	R/W	0
4.8	100BASE-TX full-duplex (For LXT971A PHY)	0 = Port is not 100BASE-TX full-duplex capable. 1 = Port is 100BASE-TX full-duplex capable.	R/W	Note 3
4.7	100BASE-TX (For LXT971A PHY)	0 = Port is not 100BASE-TX capable. 1 = Port is 100BASE-TX capable.	R/W	Note 3
4.6	10BASE-T full-duplex (For LXT971A PHY)	0 = Port is not 10BASE-T full-duplex capable. 1 = Port is 10BASE-T full-duplex capable.	R/W	Note 3
4.5	10BASE-T	0 = Port is not 10BASE-T capable. 1 = Port is 10BASE-T capable.	R/W	Note 3
4.4:0	Selector Field, S<4:0>	00001 = IEEE 802.3. 00010 = IEEE 802.9 ISLAN-16T. 00000 = Reserved for future auto-negotiation development. 11111 = Reserved for future auto-negotiation development. Note: Unspecified or reserved combinations must not be transmitted.	R/W	00001
1. R/W = Read/Write RO = Read Only 2. Default setting is determined by pin 33/H8 at reset. 3. Some bits have their default values determined at reset by hardware configuration pins. For default details for these bits, see Section 5.4.4, Hardware Configuration Settings .				

Table 51 Auto-Negotiation Link Partner Base Page Ability Register - Address 5, Hex 5

Bit	Name	Description	Type ¹	Default
5.15	Next Page	0 = Link Partner has no ability to send multiple pages. 1 = Link Partner has ability to send multiple pages.	RO	0
5.14	Acknowledge	0 = Link Partner has not received Link Code Word from the LXT971A PHY. 1 = Link Partner has received Link Code Word from the LXT971A PHY.	RO	0
5.13	Remote Fault	0 = No remote fault. 1 = Remote fault.	RO	0
5.12	Reserved	Ignore when read.	RO	0
5.11	Asymmetric Pause	Pause operation defined in IEEE 802.3 Standard, Clause 40 and 27. 0 = Link Partner is not Pause capable. 1 = Link Partner is Pause capable.	RO	0
5.10	Pause	0 = Link Partner is not Pause capable. 1 = Link Partner is Pause capable.	RO	0
5.9	100BASE-T4	0 = Link Partner is not 100BASE-T4 capable. 1 = Link Partner is 100BASE-T4 capable.	RO	0
5.8	100BASE-TX Full-Duplex	0 = Link Partner is not 100BASE-TX full-duplex capable. 1 = Link Partner is 100BASE-TX full-duplex capable.	RO	0
5.7	100BASE-TX	0 = Link Partner is not 100BASE-TX capable. 1 = Link Partner is 100BASE-TX capable.	RO	0
5.6	10BASE-T Full-Duplex	0 = Link Partner is not 10BASE-T full-duplex capable. 1 = Link Partner is 10BASE-T full-duplex capable.	RO	0
5.5	10BASE-T	0 = Link Partner is not 10BASE-T capable. 1 = Link Partner is 10BASE-T capable.	RO	0
5.4:0	Selector Field S<4:0>	<00001> = IEEE 802.3. <00010> = IEEE 802.9 ISLAN-16T. <00000> = Reserved for future auto-negotiation development. <11111> = Reserved for future auto-negotiation development. Unspecified or reserved combinations must not be transmitted.	RO	0

1. RO = Read Only

Table 52 Auto-Negotiation Expansion - Address 6, Hex 6

Bit	Name	Description	Type ¹	Default
6.15:6	Reserved	Ignore when read.	RO	0
6.5	Base Page	This bit indicates the status of the auto-negotiation variable base page. It flags synchronization with the auto-negotiation state diagram, allowing detection of interrupted links. This bit is used only if register bit 16.1 (that is, Alternate NP feature) is set. 0 = Base page = False (base page not received) 1 = Base page = True (base page received)	RO/LH	0
6.4	Parallel Detection Fault	0 = Parallel detection fault has not occurred. 1 = Parallel detection fault has occurred.	RO/LH	0
6.3	Link Partner Next Page Able	0 = Link partner is not next page able. 1 = Link partner is next page able.	RO	0
6.2	Next Page Able	0 = Local device is not next page able. 1 = Local device is next page able.	RO	1
6.1	Page Received	This bit is cleared on Read. If register bit 16.1 is set, the Page Received bit is also cleared when either mr_page_rx = false or transmit_disable = true. 1 = Indicates a new page is received and the received code word is loaded into Register 5 (Base Pages) or Register 8 (Next Pages) as specified in Clause 28 of IEEE 802.3.	RO/LH	0
6.0	Link Partner A/N Able	0 = Link partner is not auto-negotiation able. 1 = Link partner is auto-negotiation able.	RO	0

1. RO = Read Only LH = Latching High

Table 53 Auto-Negotiation Next Page Transmit Register - Address 7, Hex 7

Bit	Name	Description	Type ¹	Default
7.15	Next Page (NP)	0 = Last page 1 = Additional next pages follow	R/W	0
7.14	Reserved	Ignore when read.	RO	0
7.13	Message Page (MP)	0 = register bits 7.10:0 are user defined. 1 = register bits 7.10:0 follow IEEE message page format.	R/W	1
7.12	Acknowledge 2 (ACK2)	0 = Cannot comply with message 1 = Complies with message	R/W	0
7.11	Toggle (T)	0 = Previous value of the transmitted Link Code Word equalled logic one 1 = Previous value of the transmitted Link Code Word equalled logic zero	R/W	0
7.10:0	Message/ Unformatted Code Field	If register bits 7.13 = 0, register bits 7.10:0 are user-defined. If register bits 7.13 = 1, register bits 7.10:0 follow IEEE message page format.	R/W	0000 0000 001

1. RO = Read Only. R/W = Read/Write

Table 54 Auto-Negotiation Link Partner Next Page Receive Register - Address 8, Hex 8

Bit	Name	Description	Type ¹	Default
8.15	Next Page (NP)	0 = Link Partner has no additional next pages to send 1 = Link Partner has additional next pages to send	RO	0
8.14	Acknowledge (ACK)	0 = Link Partner has not received Link Code Word from LXT971A PHY. 1 = Link Partner has received Link Code Word from LXT971A PHY.	RO	0
8.13	Message Page (MP)	0 = register bits 8.10:0 are user defined. 1 = register bits 8.10:0 follow IEEE message page format.	RO	0
8.12	Acknowledge 2 (ACK2)	0 = Link Partner cannot comply with the message 1 = Link Partner complies with the message	RO	0
8.11	Toggle (T)	0 = Previous value of transmitted Link Code Word equal to logic one 1 = Previous value of transmitted Link Code Word equal to logic zero	RO	0
8.10:0	Message/ Unformatted Code Field	If register bit 8.13 = 0, register bits 18.10:0 are user defined. If register bit 8.13 = 1, register bits 18.10:0 follow IEEE message page format.	RO	0000 0000 00

1. RO = Read Only.

9.0 Register Definitions - Product-Specific Registers

This chapter includes definitions of product-specific LXT971A PHY registers that are defined in accordance with the IEEE 802.3 standard for adding unique device functions. (For definitions of the IEEE base registers used by the LXT971A PHY, see [Section 8.0, Register Definitions - IEEE Base Registers](#).)

- [Table 55](#) lists the register set of the product-specific registers.
- [Table 56](#) through [Table 62](#) provide bit descriptions of the product-specific registers (address 17 through 30).

Table 55 Register Set for Product-Specific Registers

Address	Register Name	Bit Assignments
16	Port Configuration Register	See Table 56
17	Status Register #2	See Table 57
18	Interrupt Enable Register	See Table 58
19	Status Change Register	See Table 59
20	LED Configuration Register	See Table 60
21	Reserved	—
22-25	Reserved	—
26	Digital Configuration Register	See Table 61
27	Reserved	—
28	Reserved	—
29	Reserved	—
30	Transmit Control Register	See Table 62
31	Reserved	—

Table 56 Configuration Register - Address 16, Hex 10 (Sheet 1 of 2)

Bit	Name	Description	Type ¹	Default
16.15	Reserved	Write as '0'. Ignore on Read.	R/W	0
16.14	Force Link Pass	0 = Normal operation 1 = Force Link pass	R/W	0
16.13	Transmit Disable	0 = Normal operation 1 = Disable Twisted Pair transmitter	R/W	0
16.12	Bypass Scrambler (10BASE-TX)	0 = Normal operation 1 = Bypass Scrambler and Descrambler	R/W	0
16.11	Reserved	Write as '0'. Ignore on Read.	R/W	0
16.10	Jabber (10BASE-T)	0 = Normal operation 1 = Disable Jabber Correction	R/W	0
16.9	SQE (10BASE-T)	0 = Disable Heart Beat 1 = Enable Heart Beat	R/W	0

1. R/W = Read /Write

Table 56 Configuration Register - Address 16, Hex 10 (Sheet 2 of 2)

Bit	Name	Description	Type ¹	Default
16.8	TP Loopback (10BASE-T)	0 = Normal operation 1 = Disable TP loopback during half-duplex operation	R/W	0
16.7	CRS Select (10BASE-T)	0 = Normal Operation 1 = CRS deassert extends to RX_DV deassert	R/W	1
16.6	Sleep Mode	0 = Disable Sleep Mode 1 = Enable Sleep Mode Note: Default value is determined by state of SLEEP pin 32/H7	R/W	—
16.5	PRE_EN	Preamble Enable. 0 = Set RX_DV high coincident with SFD. 1 = Set RX_DV high and RXD = preamble when CRS is asserted. Note: Preamble is always enabled in 100 Mbps operation.	R/W	0
16.4:3	Sleep Timer	00 = 3.04 seconds 01 = 2.00 seconds 10 = 1.04 seconds 11 = unused	R/W	00
16.2	Fault Code Enable	0 = Disable FEFI transmission 1 = Enable FEFI transmission	R/W	1
16.1	Alternate NP feature	0 = Disable alternate auto negotiate next page feature. 1 = Enable alternate auto negotiate next page feature. Note: This bit enables or disables the register bit 6.5 capability.	R/W	0
16.0	Fiber Select	0 = Select TP mode. 1 = Select fiber mode. Note: Default value is determined by state of pin 26/G2 (SD/TP_L).	R/W	—

1. R/W = Read /Write

Table 57 Status Register #2 - Address 17, Hex 11 (Sheet 1 of 2)

Bit	Name	Description	Type ¹	Default
17.15	Reserved	Always 0.	RO	0
17.14	10/100 Mode	0 = LXT971A PHY is not operating 100BASE-TX mode. 1 = LXT971A PHY is operating in 100BASE-TX mode.	RO	0
17.13	Transmit Status	0 = LXT971A PHY is not transmitting a packet. 1 = LXT971A PHY is transmitting a packet.	RO	0
17.12	Receive Status	0 = LXT971A PHY is not receiving a packet. 1 = LXT971A PHY is receiving a packet.	RO	0
17.11	Collision Status	0 = No collision. 1 = Collision is occurring.	RO	0
17.10	Link	0 = Link is down. 1 = Link is up.	RO	0

1. RO = Read Only. R/W = Read/Write

Table 57 Status Register #2 - Address 17, Hex 11 (Sheet 2 of 2)

Bit	Name	Description	Type ¹	Default
17.9	Duplex Mode	0 = Half-duplex. 1 = Full-duplex.	RO	0
17.8	Auto-Negotiation	0 = LXT971A PHY is in manual mode. 1 = LXT971A PHY is in auto-negotiation mode.	RO	0
17.7	Auto-Negotiation Complete	0 = Auto-negotiation process not completed. 1 = Auto-negotiation process completed. This bit is valid only when auto negotiate is enabled. The value is equivalent to the value of register bit 1.5.	RO	0
17.6	Reserved	Always 0.	RO	0
17.5	Polarity	0 = Polarity is not reversed. 1 = Polarity is reversed. Note: Polarity is not a valid status in 100 Mbps mode.	RO	0
17.4	Pause	0 = The LXT971A PHY is not Pause capable. 1 = The LXT971A PHY is Pause capable.	R	0
17.3	Error	0 = No error occurred 1 = Error occurred (Remote Fault, jabber, parallel detect fault) Note: The register bit is cleared when the registers that generate the error condition are read.	RO	0
17.2	Reserved	Always 0.	RO	0
17.1	Reserved	Always 0.	RO	0
17.0	Reserved	Always 0.	RO	0

1. RO = Read Only. R/W = Read/Write

Table 58 Interrupt Enable Register - Address 18, Hex 12

Bit	Name	Description	Type ¹	Default
18.15:9	Reserved	Write as '0'. Ignore on Read.	R/W	N/A
18.8	Reserved	Write as '0'. Ignore on Read.	R/W	0
18.7	ANMSK	Mask for Auto Negotiate Complete 0 = Do not allow event to cause interrupt. 1 = Enable event to cause interrupt.	R/W	0
18.6	SPEEDMSK	Mask for Speed Interrupt 0 = Do not allow event to cause interrupt. 1 = Enable event to cause interrupt.	R/W	0
18.5	DUPLEXMSK	Mask for Duplex Interrupt 0 = Do not allow event to cause interrupt. 1 = Enable event to cause interrupt.	R/W	0
18.4	LINKMSK	Mask for Link Status Interrupt 0 = Do not allow event to cause interrupt. 1 = Enable event to cause interrupt.	R/W	0
18.3	Reserved	Write as '0'. Ignore on Read.	R/W	0
18.2	Reserved	Write as '0'. Ignore on Read.	R/W	0
18.1	INTEN	Interrupt Enable. 0 = Disable interrupts. 1 = Enable interrupts.	R/W	0
18.0	TINT	Test Force Interrupt 0 = Normal operation. 1 = Force interrupt on MDINT_L	R/W	0

1. R/W = Read /Write

Table 59 Status Change Register - Address 19, Hex 13 (Sheet 1 of 2)

Bit	Name	Description	Type ¹	Default
19.15:9	Reserved	Ignore on Read.	RO	N/A
19.8	Reserved	Ignore on Read.	RO	0
19.7	ANDONE	Auto-negotiation Status 0 = Auto-negotiation has not completed. 1 = Auto-negotiation has completed.	RO/ SC	N/A
19.6	SPEEDCHG	Speed Change Status 0 = A Speed Change has not occurred since last reading this register. 1 = A Speed Change has occurred since last reading this register.	RO/ SC	0
19.5	DUPLEXCHG	Duplex Change Status 0 = A Duplex Change has not occurred since last reading this register. 1 = A Duplex Change has occurred since last reading this register.	RO/ SC	0

1. R/W = Read/Write, RO = Read Only, SC = Self Clearing.

Table 59 **Status Change Register - Address 19, Hex 13 (Sheet 2 of 2)**

Bit	Name	Description	Type ¹	Default
19.4	LINKCHG	Link Status Change Status 0 = A Link Change has not occurred since last reading this register. 1 = A Link Change has occurred since last reading this register.	RO/ SC	0
19.3	Reserved	Ignore on Read.	RO	0
19.2	MDINT_L	0 = Management data interrupt (MII interrupt) Status.No MII interrupt pending. 1 = MII interrupt pending.	RO	0
19.1	Reserved	Ignore on Read.	RO	0
19.0	Reserved	Ignore on Read.	RO	0
1. R/W = Read/Write, RO = Read Only, SC = Self Clearing.				

Table 60 LED Configuration Register - Address 20, Hex 14 (Sheet 1 of 2)

Bit	Name	Description	Type ¹	Default
20.15:12	LED1 Programming bits	0000 = Display Speed Status (Continuous, Default) 0001 = Display Transmit Status (Stretched) 0010 = Display Receive Status (Stretched) 0011 = Display Collision Status (Stretched) 0100 = Display Link Status (Continuous) 0101 = Display Duplex Status (Continuous) 0110 = Unused 0111 = Display Receive or Transmit Activity (Stretched) 1000 = Test mode - turn LED on (Continuous) 1001 = Test mode - turn LED off (Continuous) 1010 = 1010 = Test mode - blink LED fast (Continuous) 1011 = Test mode - blink LED slow (Continuous) 1100 = Display Link and Receive Status combined ² (Stretched) ³ 1101 = Display Link and Activity Status combined ² (Stretched) ³ 1110 = Display Duplex and Collision Status combined ⁴ (Stretched) ³ 1111 = Unused	R/W	0000
20.11:8	LED2 Programming bits	0000 = 0000 = Display Speed Status 0001 = Display Transmit Status 0010 = Display Receive Status 0011 = Display Collision Status 0100 = Display Link Status (Default) 0101 = Display Duplex Status 0110 = Unused 0111 = Display Receive or Transmit Activity 1000 = Test mode - turn LED on 1001 = Test mode - turn LED off 1010 = Test mode - blink LED fast 1011 = Test mode - blink LED slow 1100 = Display Link and Receive Status combined ² (Stretched) ³ 1101 = Display Link and Activity Status combined ² (Stretched) ³ 1110 = Display Duplex and Collision Status combined ⁴ (Stretched) ³ 1111 = Unused	R/W	0100
<ol style="list-style-type: none"> 1. R/W = Read /Write. RO = Read Only. LH = Latching High 2. Link status is the primary LED driver. The LED is asserted (solid ON) when the link is up. The secondary LED driver (Receive or Activity) causes the LED to change state (blink). Activity causes the LED to blink, regardless of the link status. 3. Combined event LED settings are not affected by Pulse Stretch register bit 20.1. These display settings are stretched regardless of the value of 20.1. 4. Duplex status is the primary LED driver. The LED is asserted (solid ON) when the link is full-duplex. Collision status is the secondary LED driver. The LED changes state (blinks) when a collision occurs. 5. Values are approximations. Not guaranteed or production tested. 				

Table 60 LED Configuration Register - Address 20, Hex 14 (Sheet 2 of 2)

Bit	Name	Description	Type ¹	Default
20.7:4	LED3 Programming bits	0000 = Display Speed Status 0001 = Display Transmit Status 0010 = Display Receive Status (Default) 0011 = Display Collision Status 0100 = Display Link Status 0101 = Display Duplex Status 0110 = Unused 0111 = Display Receive or Transmit Activity 1000 = Test mode- turn LED on 1001 = Test mode- turn LED off 1010 = Test mode- blink LED fast 1011 = Test mode- blink LED slow 1100 = Display Link and Receive Status combined ² (Stretched) ³ 1101 = Display Link and Activity Status combined ² (Stretched) ³ 1110 = Display Duplex and Collision Status combined ⁴ (Stretched) ³ 1111 = Unused	R/W	0010
20.3:2	LEDFREQ ⁵	00 = Stretch LED events to 30 ms. 01 = Stretch LED events to 60 ms. 10 = Stretch LED events to 100 ms. 11 = Reserved.	R/W	00
20.1	PULSE-STRETCH	0 = Disable pulse stretching of all LEDs. 1 = Enable pulse stretching of all LEDs.	R/W	1
20.0	Reserved	Write as '0'. Ignore on Read.	R/W	0
1. R/W = Read /Write. RO = Read Only. LH = Latching High 2. Link status is the primary LED driver. The LED is asserted (solid ON) when the link is up. The secondary LED driver (Receive or Activity) causes the LED to change state (blink). Activity causes the LED to blink, regardless of the link status. 3. Combined event LED settings are not affected by Pulse Stretch register bit 20.1. These display settings are stretched regardless of the value of 20.1. 4. Duplex status is the primary LED driver. The LED is asserted (solid ON) when the link is full-duplex. Collision status is the secondary LED driver. The LED changes state (blinks) when a collision occurs. 5. Values are approximations. Not guaranteed or production tested.				

Table 61 Digital Configuration Register - Address 26, Hex 1A (Sheet 1 of 2)

Bit	Name	Description	Type ¹	Default
26.15:12	Reserved	Write as '0'. Ignore on Read.	R/W	0000
26.11	MII Drive Strength	MII Drive Strength 0 = Normal MII drive strength 1 = Increase MII drive strength	R/W	0
26.10	Reserved	Write as '0'. Ignore on Read.	R/W	0
26.9	Show Symbol Error	Show Symbol Error 0 = Normal MII_RXER 1 = 100BASE-X Error Signal to MII_RxER	R/W	0
26.8:6	Reserved	Write as '0'. Ignore on Read.	RO	0
1. R/W = Read /Write, RO = Read Only				

Table 61 Digital Configuration Register - Address 26, Hex 1A (Sheet 2 of 2)

Bit	Name	Description	Type ¹	Default
26.5:4	Reserved	Write as '0'. Ignore on Read.	R/W	00
26.3	Reserved	Write as '0'. Ignore on Read.	RO	0
26.2:0	Reserved	Write as '0'. Ignore on Read.	R/W	0

1. R/W = Read /Write, RO = Read Only

Table 62 Transmit Control Register - Address 30, Hex 1E

Bit	Name	Description	Type ²	Default
30.15:13	Reserved	Write as '0'. Ignore on Read.	R/W	000
30.12	Transmit Low Power	Transmit Low Power 0 = Normal transmission. 1 = Forces the transmitter into low power mode. Also forces a zero-differential transmission.	R/W	0
30.11:10	Port Rise Time Control ¹	Port Rise Time Control 00 = 3.0 ns (Default = Setting on TXSLEW[1:0] pins) 01 = 3.4 ns 10 = 3.9 ns 11 = 4.4 ns	R/W	Note 3
30.4:0	Reserved	Ignore on Read.	R/W	0

1. Values are approximations and may vary outside indicated values based upon implementation loading conditions.
 2. R/W = Read/Write
 3. Latch State during Reset is based on the state of hardware configuration pins at RESET_L.

10.0 Package Specifications

Figure 44 PBGA Package Specification

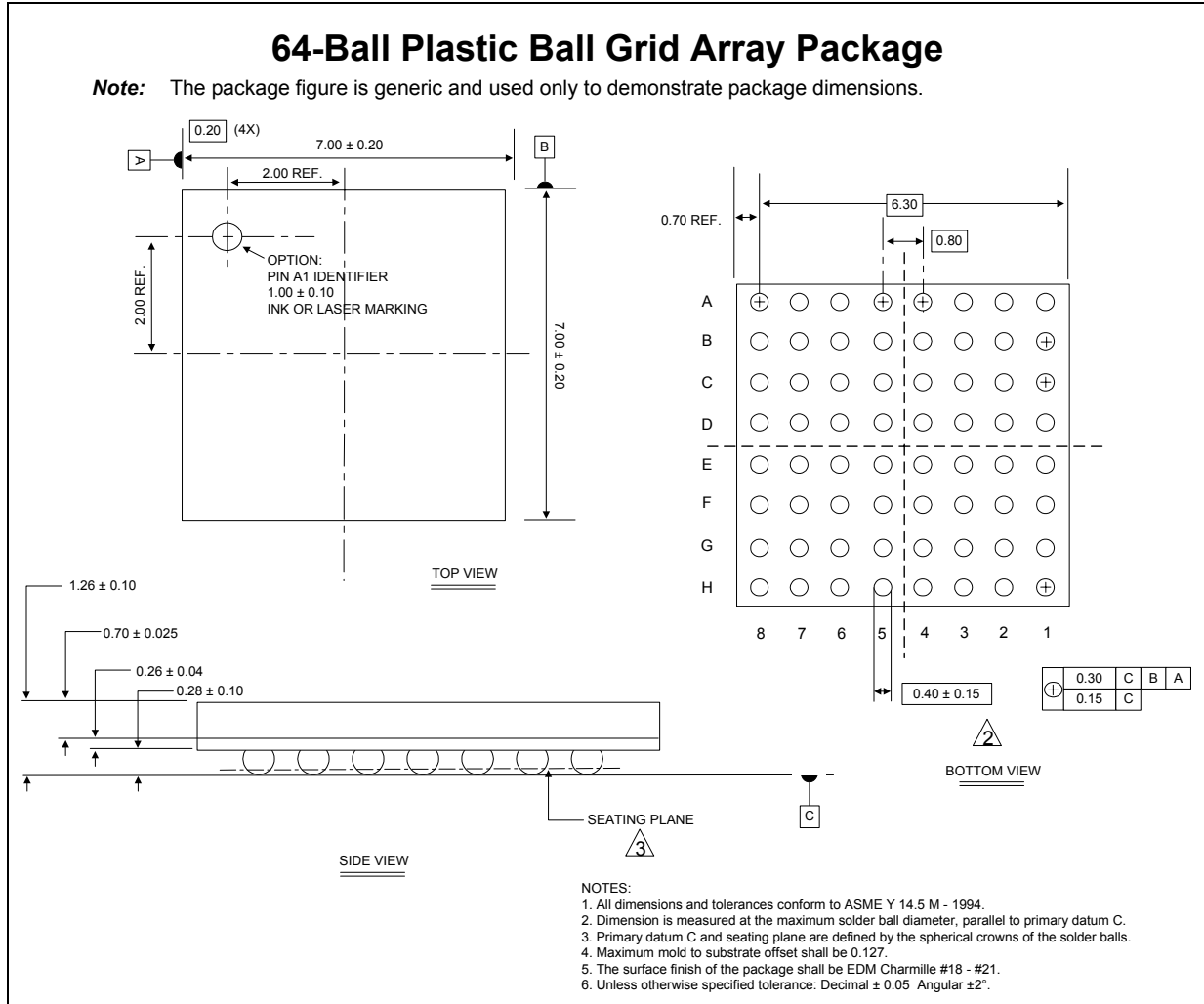
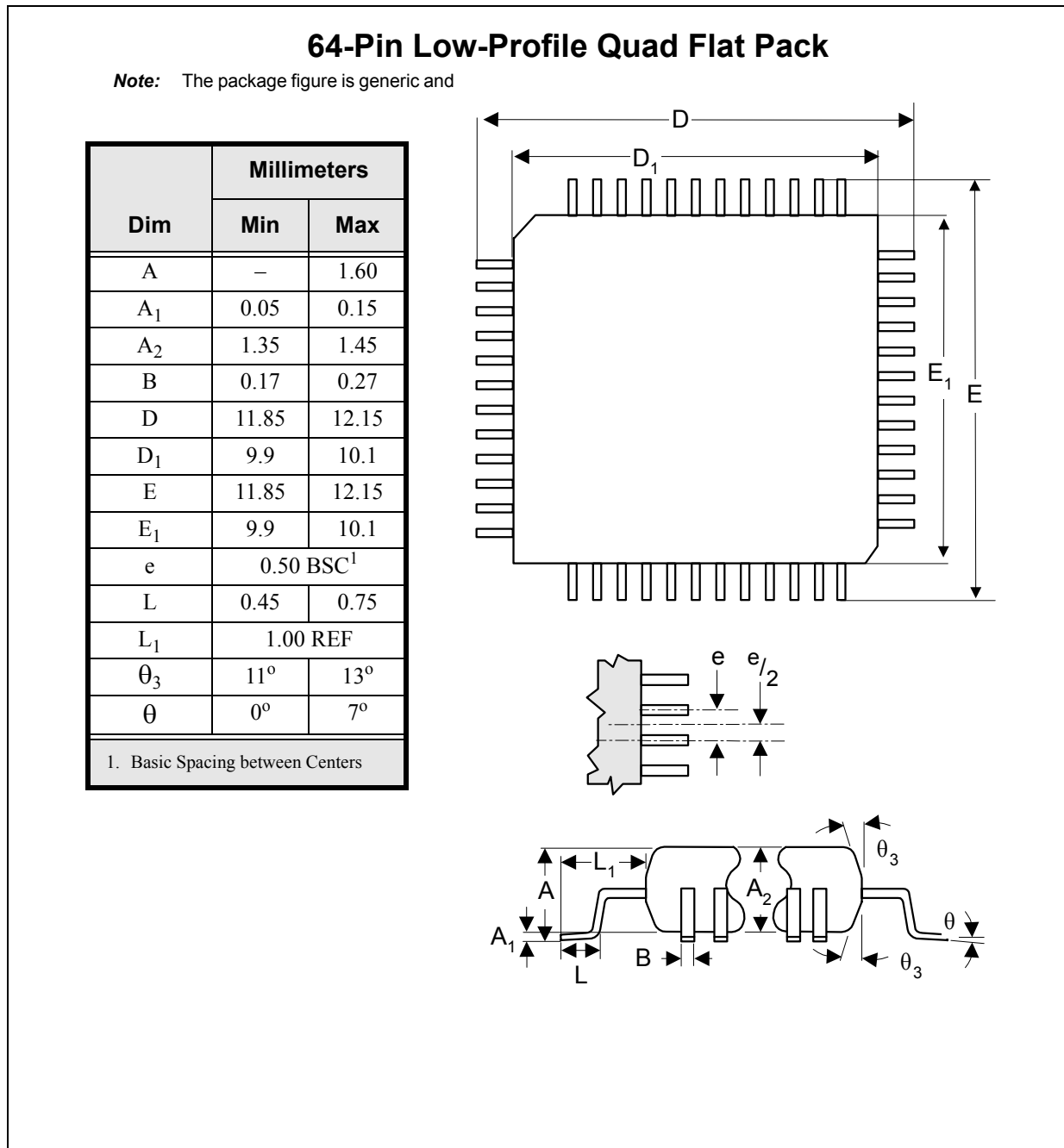

Figure 45 LQFP Package Specifications





For additional product and ordering information:

www.cortina-systems.com

Looking for pricing, stock, or lifecycle information?

Click below to explore more details on WIN SOURCE:

 [View ELLXT971ABE.A4-870479 on WIN SOURCE](#)

 [Inphi Corporation](#) Information

Optimize Your Supply Chain with WIN SOURCE Solutions

-  Global Sourcing Solution
-  Obsolete Management
-  Cost Control Management
-  Shortage Management
-  Alternative Solution
-  Excess Inventory Management