



**THE DATASHEET OF
840021AGILFT**





General Description



The ICS840021I is a Gigabit Ethernet Clock Generator. The ICS840021I uses a 25MHz crystal to synthesize 125MHz. The ICS840021I has excellent phase jitter performance, over the 1.875MHz – 20MHz integration range. The ICS840021I is packaged in a small 8-pin TSSOP and 16-pin VFQFN, making it ideal for use in systems with limited board space.

Features

- One LVCMOS/LVTTL output, 15Ω output impedance
- Crystal oscillator interface designed for 25MHz, 18pF parallel resonant crystal
- Output frequency: 125MHz
- VCO range: 560MHz to 680MHz
- RMS phase jitter @ 125MHz, using a 25MHz crystal (1.875MHz - 20MHz): 0.48ps (typical) 3.3V
- RMS phase noise at 125MHz (typical)
- Phase noise:

Offset	Noise Power
100Hz	-97.8 dBc/Hz
1kHz	-124.6 dBc/Hz
10kHz	-132.5 dBc/Hz
100Hz	-131.1 dBc/Hz

Pin Assignments

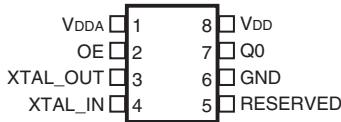

ICS840021I

8-Lead TSSOP

4.40mm x 3.0mm x 0.925mm package body

G Package
Top View

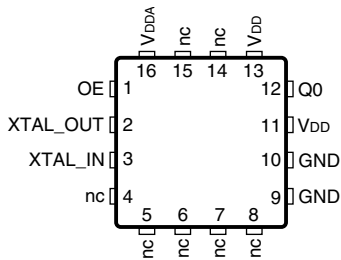

ICS840021I

16-Lead VFQFN

3.0mm x 3.0mm x 0.925mm package body

K Package
Top View

Block Diagram

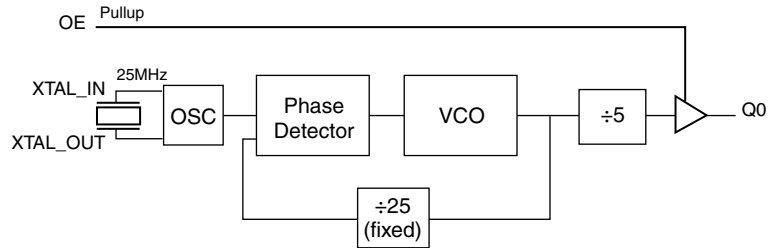

Table 1. Pin Descriptions

Name	Type		Description
V _{DDA}	Power		Analog supply pin.
OE	Input	Pullup	Output enable pin. When HIGH, Q0 output is enabled. When LOW, forces Q0 to high-impedance state. LVCMOS/LVTTL interface levels.
XTAL_OUT, XTAL_IN	Input		Crystal oscillator interface. XTAL_IN is the input, XTAL_OUT is the output.
nc	Unused		No connect.
RESERVED	Reserved		Reserved pin.
GND	Power		Power supply ground.
Q0	Output		Single-ended clock output. LVCMOS/LVTTL interface levels. 15Ω output impedance.
V _{DD}	Power		Core supply pin.

NOTE: *Pullup* refers to internal input resistors. See Table 1, *Pin Characteristics*, for typical values.

Table 2. Pin Characteristics

Symbol	Parameter	Test Conditions	Minimum	Typical	Maximum	Units
C _{IN}	Input Capacitance			4		pF
C _{PD}	Power Dissipation Capacitance	V _{DD} = 3.465V		7		pF
		V _{DD} = 2.625V		7		pF
R _{PULLUP}	Input Pullup Resistor			51		kΩ
R _{OUT}	Output Impedance			15		Ω

Function Table

Table 3. Control Function Table

Control Input	Output
OE	Q0
0	High-Impedance
1	Active

Absolute Maximum Ratings

NOTE: Stresses beyond those listed under *Absolute Maximum Ratings* may cause permanent damage to the device. These ratings are stress specifications only. Functional operation of product at these conditions or any conditions beyond

those listed in the *DC Characteristics* or *AC Characteristics* is not implied. Exposure to absolute maximum rating conditions for extended periods may affect product reliability.

Item	Rating
Supply Voltage, V_{DD}	4.6V
Inputs, V_I	-0.5V to $V_{DD} + 0.5V$
Outputs, V_O	-0.5V to $V_{DD} + 0.5V$
Package Thermal Impedance, θ_{JA} 8 TSSOP 16 VFQFN	101.7°C/W (0 mps) 74.9°C/W (0 mps)
Storage Temperature, T_{STG}	-65°C to 150°C

DC Electrical Characteristics

Table 4A. Power Supply DC Characteristics, $V_{DD} = 3.3V \pm 5\%$, $T_A = -40^\circ\text{C}$ to 85°C

Symbol	Parameter	Test Conditions	Minimum	Typical	Maximum	Units
V_{DD}	Core Supply Voltage		3.135	3.3	3.465	V
V_{DDA}	Analog Supply Voltage		3.135	3.3	3.465	V
I_{DD}	Power Supply Current				65	mA
I_{DDA}	Analog Supply Current				10	mA

Table 4B. Power Supply DC Characteristics, $V_{DD} = 2.5V \pm 5\%$, $T_A = -40^\circ\text{C}$ to 85°C

Symbol	Parameter	Test Conditions	Minimum	Typical	Maximum	Units
V_{DD}	Core Supply Voltage		2.375	2.5	2.625	V
V_{DDA}	Analog Supply Voltage		2.375	2.5	2.625	V
I_{DD}	Power Supply Current				60	mA
I_{DDA}	Analog Supply Current				10	mA

Table 4C. LVCMOS/LVTTL DC Characteristics, $V_{DD} = 3.3V \pm 5\%$ OR $2.5V \pm 5\%$, $T_A = -40^\circ C$ to $85^\circ C$

Symbol	Parameter	Test Conditions	Minimum	Typical	Maximum	Units
V_{IH}	Input High Voltage	$V_{DD} = 3.3V$	2		$V_{DD} + 0.3$	V
		$V_{DD} = 2.5V$	1.7		$V_{DD} + 0.3$	V
V_{IL}	Input Low Voltage	$V_{DD} = 3.3V$	-0.3		0.8	V
		$V_{DD} = 2.5V$	-0.3		0.7	V
I_{IH}	Input High Current	OE	$V_{DD} = V_{IN} = 3.465V$ OR $2.625V$		5	μA
I_{IL}	Input Low Current	OE	$V_{DD} = 3.465V$ OR $2.625V$, $V_{IN} = 0V$		-150	μA
V_{OH}	Output High Voltage; NOTE 1	$V_{DD} = 3.465V$	2.6			V
		$V_{DD} = 2.625V$	1.8			V
V_{OL}	Output High Voltage; NOTE 1	$V_{DD} = 3.465V$ OR $2.625V$			0.5	V

NOTE 1: Outputs terminated with 50Ω to $V_{DD}/2$. See Parameter Measurement Information Section, "3.3V Output Load Test Circuit" diagrams.

Table 5. Crystal Characteristics

Parameter	Test Conditions	Minimum	Typical	Maximum	Units
Mode of Oscillation		Fundamental			
Frequency			25		MHz
Equivalent Series Resistance (ESR)				50	Ω
Shunt Capacitance				7	pF
Drive Level				1	mW

AC Electrical Characteristics

Table 6A. AC Characteristics, $V_{DD} = 3.3V \pm 5\%$, $T_A = -40^\circ\text{C}$ to 85°C

Symbol	Parameter	Test Conditions	Minimum	Typical	Maximum	Units
f_{OUT}	Output Frequency			125		MHz
$\text{jit}(\emptyset)$	RMS Phase Jitter, Random; NOTE 1	Integration Range: 1.875MHz – 20MHz		0.48		ps
t_R / t_F	Output Rise/Fall Time	20% to 80%	200		500	ps
odc	Output Duty Cycle		48		52	%

NOTE: Electrical parameters are guaranteed over the specified ambient operating temperature range, which is established when the device is mounted in a test socket with maintained transverse airflow greater than 500 lpm. The device will meet specifications after thermal equilibrium has been reached under these conditions.

NOTE 1: Please refer to Phase Noise Plots.

Table 6B. AC Characteristics, $V_{DD} = 2.5V \pm 5\%$, $T_A = -40^\circ\text{C}$ to 85°C

Symbol	Parameter	Test Conditions	Minimum	Typical	Maximum	Units
f_{OUT}	Output Frequency			125		MHz
$\text{jit}(\emptyset)$	RMS Phase Jitter, Random; NOTE 1	Integration Range: 1.875MHz – 20MHz		0.50		ps
t_R / t_F	Output Rise/Fall Time	20% to 80%	250		550	ps
odc	Output Duty Cycle		48		52	%

NOTE: Electrical parameters are guaranteed over the specified ambient operating temperature range, which is established when the device is mounted in a test socket with maintained transverse airflow greater than 500 lpm. The device will meet specifications after thermal equilibrium has been reached under these conditions.

NOTE 1: Please refer to Phase Noise Plots.

Typical Phase Noise at 125MHz (3.3V OR 2.5V)

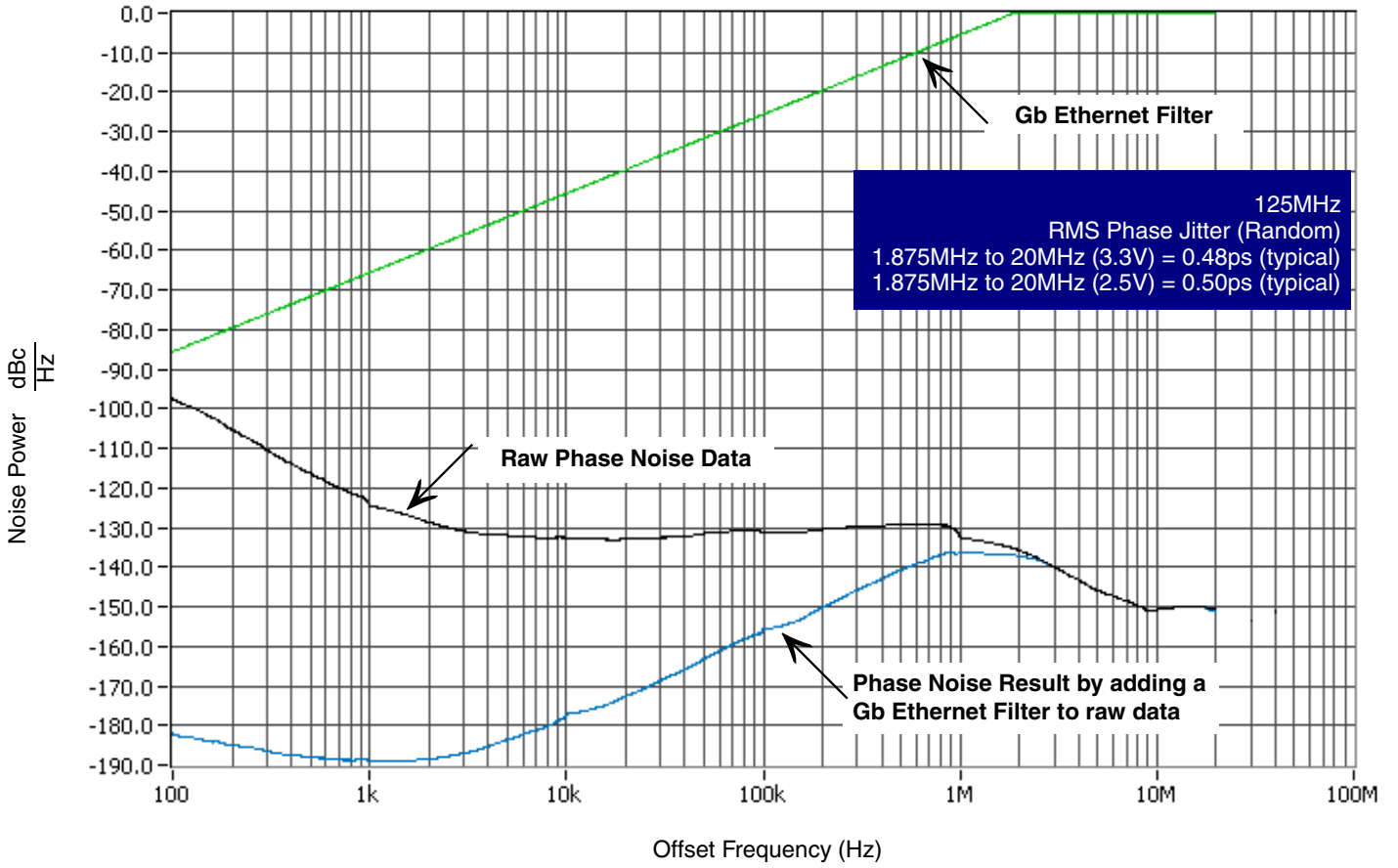

Parameter Measurement Information

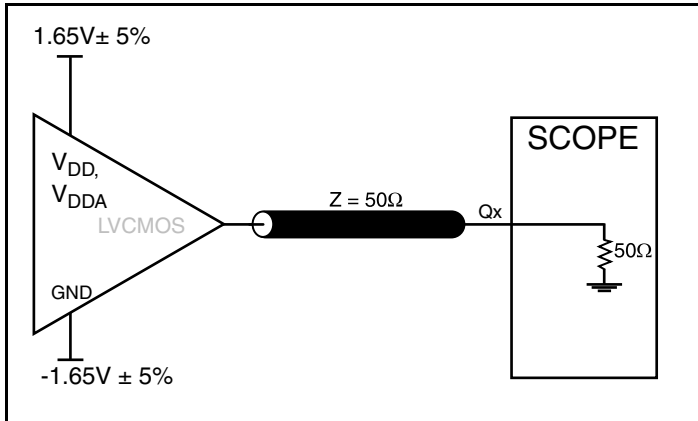

3.3V Output Load AC Test Circuit

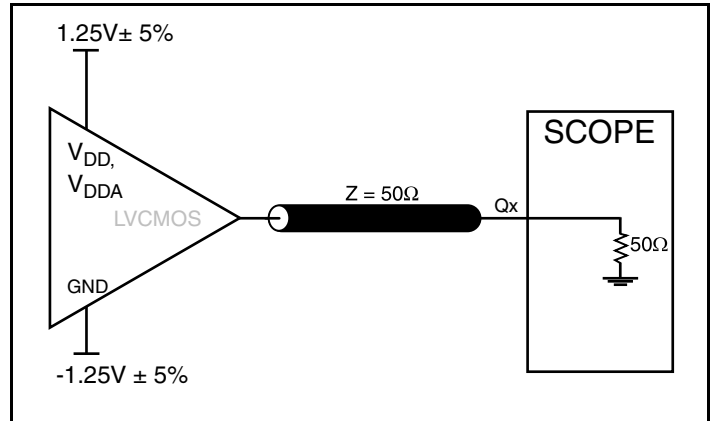

2.5V Output Load AC Test Circuit

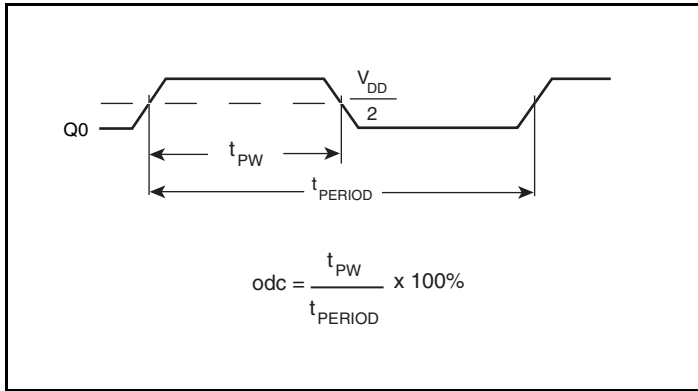

Output Duty Cycle/Pulse Width/Period

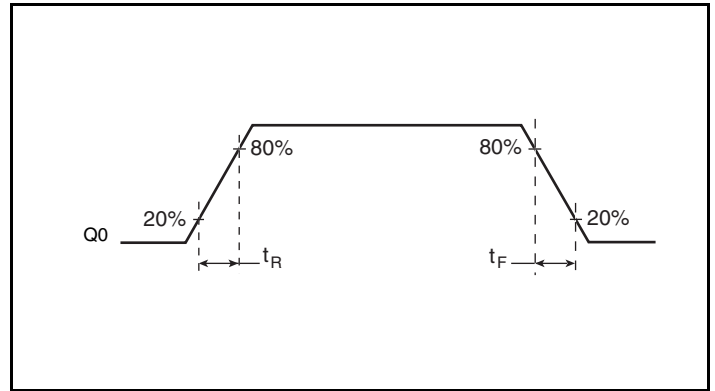

Output Rise/Fall Time

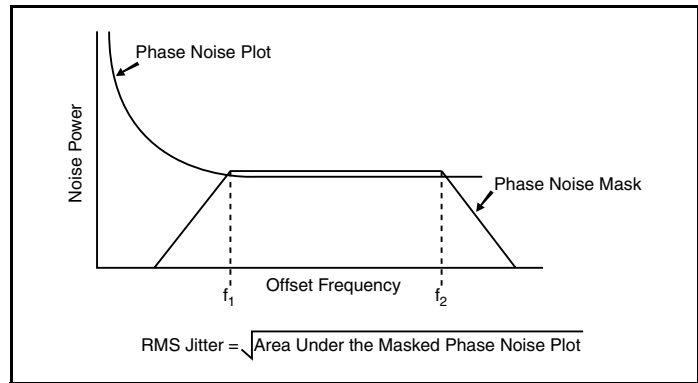

RMS Phase Jitter

Application Information

Power Supply Filtering Technique

As in any high speed analog circuitry, the power supply pins are vulnerable to random noise. To achieve optimum jitter performance, power supply isolation is required. ICS840021I provides separate power supplies to isolate any high switching noise from the outputs to the internal PLL. V_{DD} and V_{DDA} should be individually connected to the power supply plane through vias, and $0.01\mu\text{F}$ bypass capacitors should be used for each pin. *Figure 1* illustrates this for a generic V_{DD} pin and also shows that V_{DDA} requires that an additional 10Ω resistor along with a $10\mu\text{F}$ bypass capacitor be connected to the V_{DDA} pin.

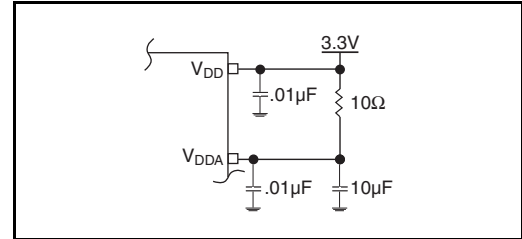

Figure 1. Power Supply Filtering

Crystal Input Interface

The ICS840021I has been characterized with 18pF parallel resonant crystals. The capacitor values, $C1$ and $C2$, shown in *Figure 2* below were determined using a 25MHz , 18pF parallel resonant crystal and were chosen to minimize the ppm error. The optimum $C1$ and $C2$ values can be slightly adjusted for different board layouts.

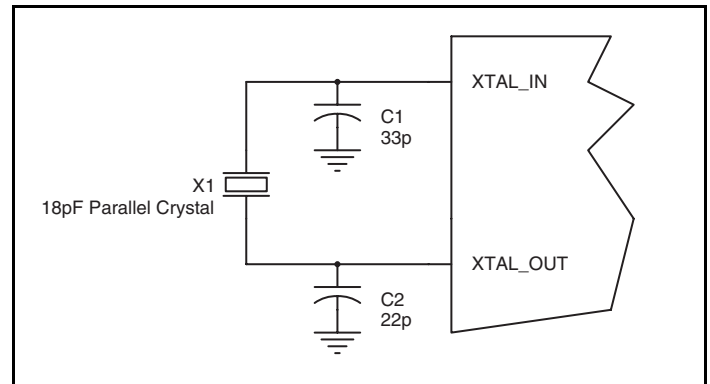

Figure 2. Crystal Input Interface

LVCMOS to XTAL Interface

The XTAL_IN input can accept a single-ended LVCMOS signal through an AC coupling capacitor. A general interface diagram is shown in *Figure 3*. The XTAL_OUT pin can be left floating. The input edge rate can be as slow as 10ns. For LVCMOS signals, it is recommended that the amplitude be reduced from full swing to half swing in order to prevent signal interference with the power rail and to reduce noise. This configuration requires that the output

impedance of the driver (R_o) plus the series resistance (R_s) equals the transmission line impedance. In addition, matched termination at the crystal input will attenuate the signal in half. This can be done in one of two ways. First, R_1 and R_2 in parallel should equal the transmission line impedance. For most 50Ω applications, R_1 and R_2 can be 100Ω . This can also be accomplished by removing R_1 and making R_2 50Ω .

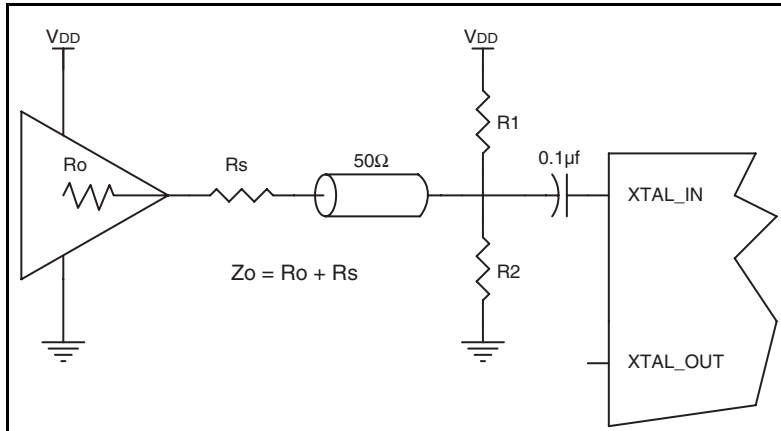

Figure 3. General Diagram for LVCMOS Driver to XTAL Input Interface

Application Schematic

Figure 4A shows a schematic example of the ICS840021I. An example of LVCMOS termination is shown in this schematic. Additional LVCMOS termination approaches are shown in the LVCMOS Termination Application Note. In this example, an 18pF

parallel resonant 25MHz crystal is used for generating 125MHz output frequency. The C1 = 22pF and C2 = 33pF are recommended for frequency accuracy. For different board layout, the C1 and C2 values may be slightly adjusted for optimizing frequency accuracy.

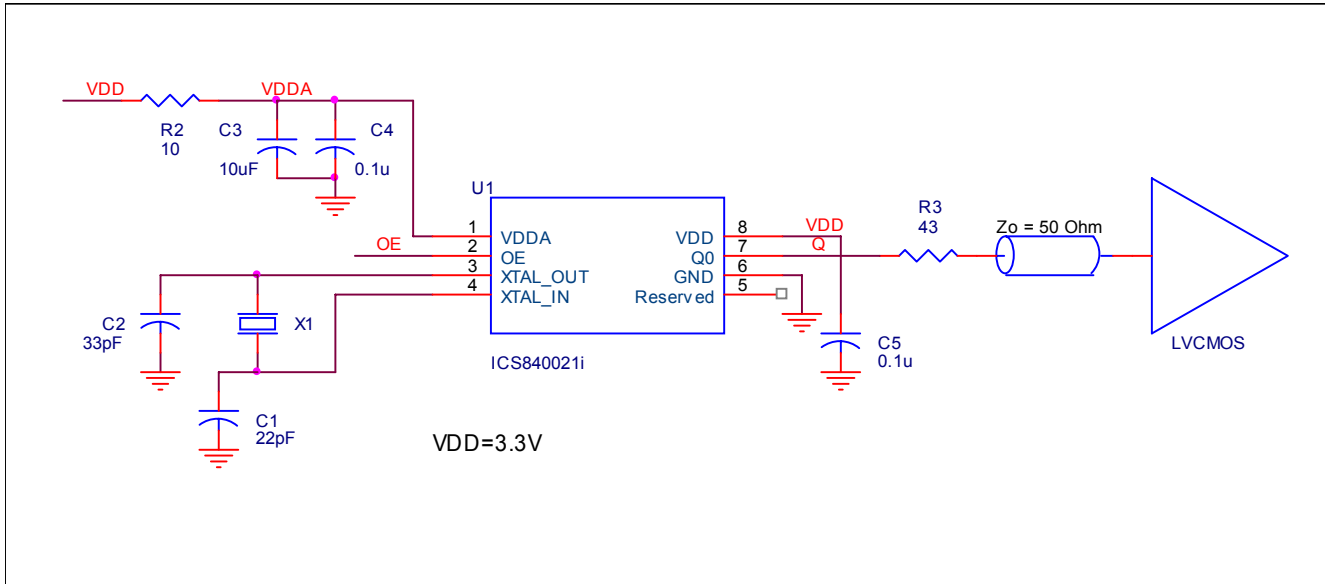

Figure 4A. ICS840021I Schematic Example

PC BOARD LAYOUT EXAMPLE

Figure 4B shows an example of ICS840021I P.C. board layout. The crystal X1 footprint shown in this example allows installation of either surface mount HC49S or through-hole HC49 package. The footprints of other components in this example are listed in the Table 7. There

should be at least one decoupling capacitor per power pin. The decoupling capacitors should be located as close as possible to the power pins. The layout assumes that the board has clean analog power ground plane.

Table 7. Footprint Table

Reference	Size
C1, C2	0402
C3	0805
C4, C5	0603
R2, R3	0603

NOTE: Table 7, lists component sizes shown in this layout example.

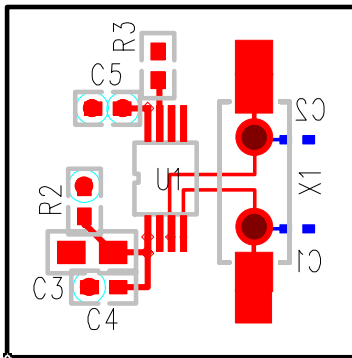

Figure 4B. ICS840021I PC Board Layout Example

Reliability Information

Table 8A. θ_{JA} vs. Air Flow Table for a 8 Lead TSSOP

θ_{JA} vs. Air Flow			
Meters per Second	0	1	2.5
Multi-Layer PCB, JEDEC Standard Test Boards	101.7°C/W	90.5°C/W	89.8°C/W

Table 8B. θ_{JA} vs. Air Flow Table for a 16 Lead VFQFN

θ_{JA} vs. Air Flow			
Meters per Second	0	1	2.5
Multi-Layer PCB, JEDEC Standard Test Boards	74.97°C/W	65.5°C/W	58.8°C/W

Transistor Count

The transistor count for ICS840021I is: 1961

Package Outline and Package Dimensions

Package Outline - G Suffix for 8 Lead TSSOP

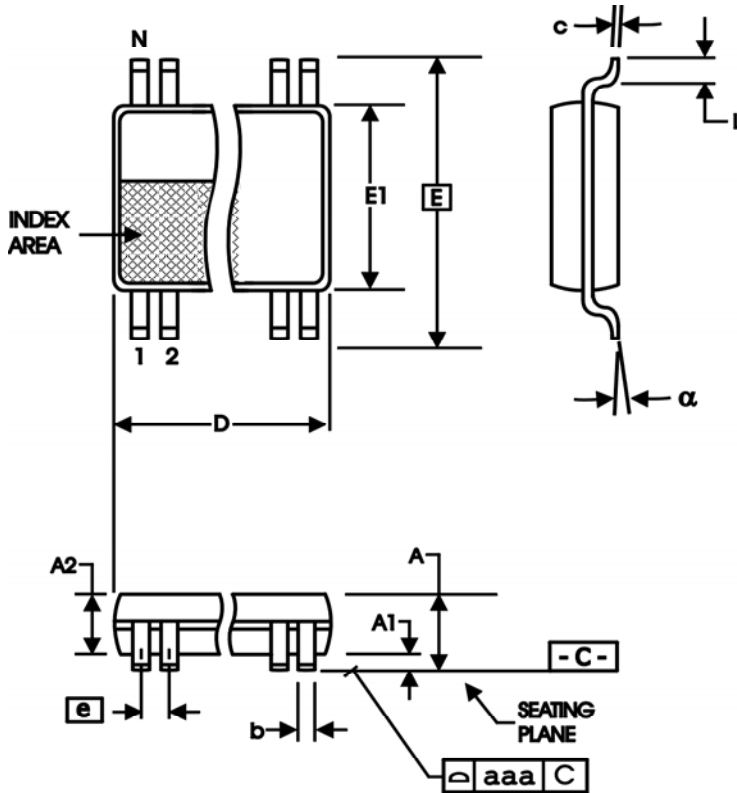
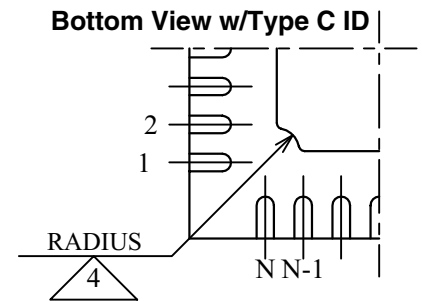
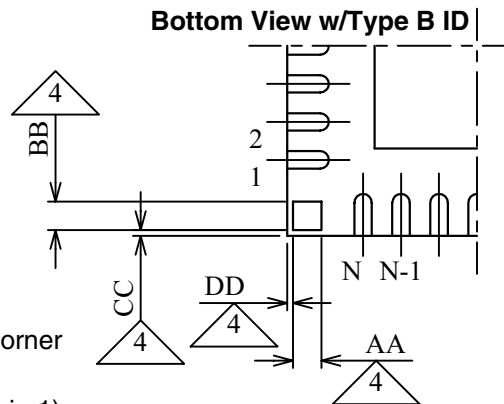
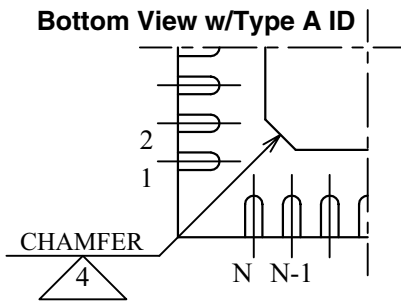
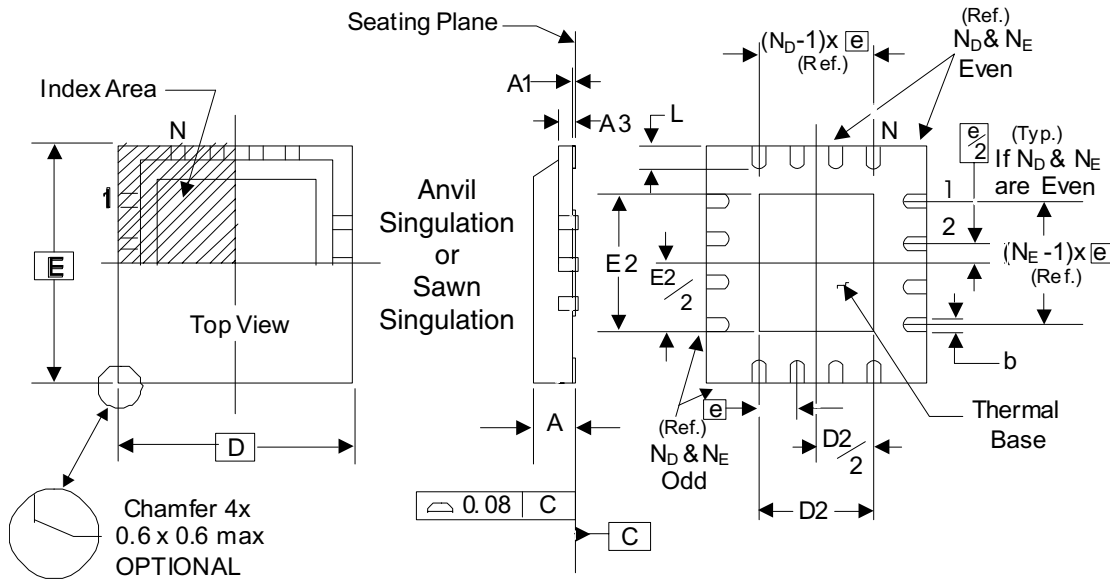

Table 9A. Package Dimensions

All Dimensions in Millimeters		
Symbol	Minimum	Maximum
N	8	
A		1.20
A1	0.5	0.15
A2	0.80	1.05
b	0.19	0.30
c	0.09	0.20
D	2.90	3.10
E	6.40 Basic	
E1	4.30	4.50
e	0.65 Basic	
L	0.45	0.75
α	0°	8°
aaa		0.10

Reference Document: JEDEC Publication 95, MO-153

Package Outline - K Suffix for 16 Lead VFQFN



There are 3 methods of indicating pin 1 corner at the back of the VFQFN package are:

1. Type A: Chamfer on the paddle (near pin 1)
2. Type B: Dummy pad between pin 1 and N .
3. Type C: Mouse bite on the paddle (near pin 1)

Table 9B. Package Dimensions

JEDEC Variation: VEED-2/-4		
All Dimensions in Millimeters		
Symbol	Minimum	Maximum
N	16	
A	0.80	1.00
$A1$	0	0.05
$A3$	0.25 Ref.	
b	0.18	0.30
N_D & N_E	4	
D & E	3.00 Basic	
$D2$ & $E2$	1.00	1.80
e	0.50 Basic	
L	0.30	0.50

Reference Document: JEDEC Publication 95, MO-220

Ordering Information

Table 10. Ordering Information

Part/Order Number	Marking	Package	Shipping Packaging	Temperature
840021AGI	021AI	8 Lead TSSOP	Tube	-40°C to 85°C
840021AGIT	021AI	8 Lead TSSOP	2500 Tape & Reel	-40°C to 85°C
840021AGILF	21AIL	"Lead-Free" 8 Lead TSSOP	Tube	-40°C to 85°C
840021AGILFT	21AIL	"Lead-Free" 8 Lead TSSOP	2500 Tape & Reel	-40°C to 85°C
840021AKILF	1AIL	"Lead-Free" 16 Lead VFQFN	Tray	-40°C to 85°C
840021AKILFT	1AIL	"Lead-Free" 16 Lead VFQFN	2500 Tape & Reel	-40°C to 85°C

NOTE: Parts that are ordered with an "LF" suffix to the part number are the Pb-Free configuration and are RoHS compliant.

While the information presented herein has been checked for both accuracy and reliability, Integrated Device Technology (IDT) assumes no responsibility for either its use or for the infringement of any patents or other rights of third parties, which would result from its use. No other circuits, patents, or licenses are implied. This product is intended for use in normal commercial and industrial applications. Any other applications, such as those requiring high reliability or other extraordinary environmental requirements are not recommended without additional processing by IDT. IDT reserves the right to change any circuitry or specifications without notice. IDT does not authorize or warrant any IDT product for use in life support devices or critical medical instruments.

Revision History Sheet

Rev	Table	Page	Description of Change	Date
A	T10	11	Ordering Information Table - Added Lead-Free Marking.	7-30-07
A		9	Added <i>LVCMOS to XTAL Interface</i> section. Changed formatting throughout data sheet	1-20-09
B	T1	1 2	Pin Assignment - changed pin 5 from nc to Reserved. Pin Description Table - changed pin 5 from nc to Reserved.	5/4/09
C	T8B T9B 10	1 3 11 13 14	Add 16 VFQFN Pin Assignment. Absolute Maximum Ratings - added 16 VFQFN Package Thermal Impedance information. Added 16 VFQFN Air Flow Table. Added 16 VFQFN Package Drawing and Dimensions. Ordering Information Table - added 16 VFQFN ordering information.	6/25/09
C			Deleted "Proposed" label throughout the datasheet.	7/14/09
C		1 13	Feature Section corrected temperature bullet from 40°C to -40°C. Added new VFQFN bottom view package drawing.	1/27/10



www.IDT.com

6024 Silver Creek Valley Road
San Jose, California 95138

Sales
800-345-7015 (inside USA)
+408-284-8200 (outside USA)
Fax: 408-284-2775
www.IDT.com/go/contactIDT

Technical Support
netcom@idt.com
+480-763-2056

DISCLAIMER Integrated Device Technology, Inc. (IDT) and its subsidiaries reserve the right to modify the products and/or specifications described herein at any time and at IDT's sole discretion. All information in this document, including descriptions of product features and performance, is subject to change without notice. Performance specifications and the operating parameters of the described products are determined in the independent state and are not guaranteed to perform the same way when installed in customer products. The information contained herein is provided without representation or warranty of any kind, whether express or implied, including, but not limited to, the suitability of IDT's products for any particular purpose, an implied warranty of merchantability, or non-infringement of the intellectual property rights of others. This document is presented only as a guide and does not convey any license under intellectual property rights of IDT or any third parties.

IDT's products are not intended for use in life support systems or similar devices where the failure or malfunction of an IDT product can be reasonably expected to significantly affect the health or safety of users. Anyone using an IDT product in such a manner does so at their own risk, absent an express, written agreement by IDT.

Integrated Device Technology, IDT and the IDT logo are registered trademarks of IDT. Other trademarks and service marks used herein, including protected names, logos and designs, are the property of IDT or their respective third party owners.

Copyright 2010. All rights reserved.

Looking for pricing, stock, or lifecycle information?

Click below to explore more details on WIN SOURCE:

- ⊖ [View 840021AGILFT on WIN SOURCE](#)
- ⊖ [IDT, Integrated Device Technology Inc Information](#)

Optimize Your Supply Chain with WIN SOURCE Solutions

- ✓ Global Sourcing Solution
- ✓ Obsolete Management
- ✓ Cost Control Management
- ✓ Shortage Management
- ✓ Alternative Solution
- ✓ Excess Inventory Management