



**THE DATASHEET OF  
841608AKILFT**



## General Description

The 841608 is an optimized PCIe and sRIO clock generator. The device uses a 25MHz parallel crystal to generate 100MHz and 125MHz clock signals, replacing solutions requiring multiple oscillator and fanout buffer solutions. The device has excellent phase jitter (< 1ps rms) suitable to clock components requiring precise and low-jitter PCIe or sRIO or both clock signals. Designed for telecom, networking and industrial applications, the 841608 can also drive the high-speed sRIO and PCIe SerDes clock inputs of communication processors, DSPs, switches and bridges.

## Features

- Eight HCSL outputs: configurable for PCIe (100MHz) and sRIO (125MHz) clock signals
- Selectable crystal oscillator interface, 25MHz, 18pF parallel resonant crystal or LVCMOS/LVTTL single-ended reference clock input
- Supports the following output frequencies: 100MHz or 125MHz
- VCO: 500MHz
- PLL bypass and output enable
- PCI Express (2.5 Gb/S) and Gen 2 (5 Gb/s) jitter compliant
- RMS phase jitter @ 125MHz, using a 25MHz crystal (1.875MHz – 20MHz): 0.37ps (typical)
- Full 3.3V operating supply
- -40°C to 85°C ambient operating temperature
- Available in lead-free (RoHS 6) package

## Block Diagram

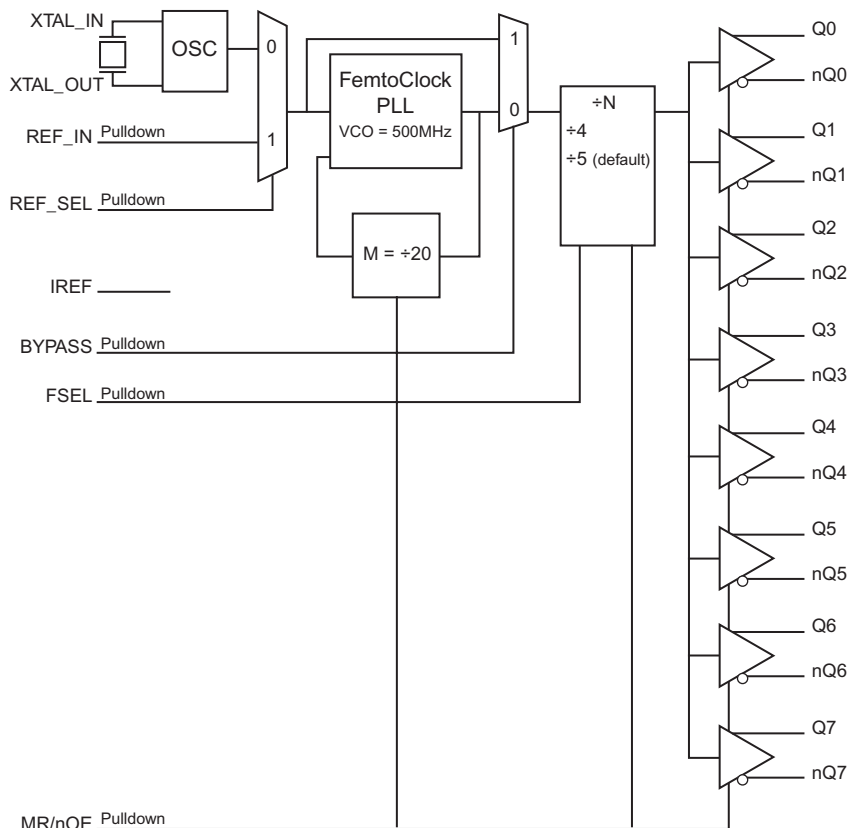

## Pin Assignment

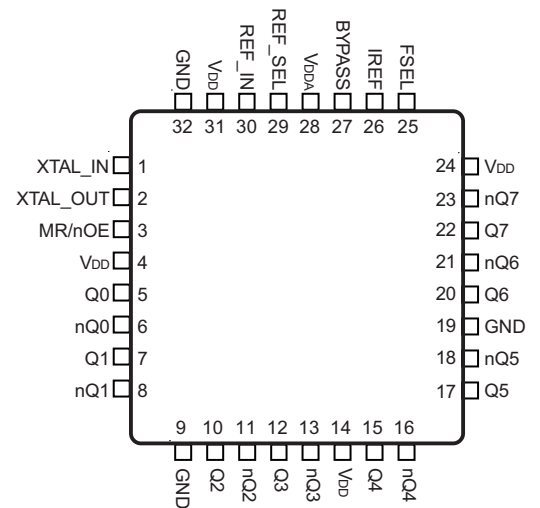

**841608**  
**32-Lead VFQFN**  
**5mm x 5mm x 0.925mm package body**  
**K Package**  
**Top View**

## Pin Description and Pin Characteristic Tables

**Table 1. Pin Descriptions**

Number	Name	Type		Description
1, 2	XTAL_IN, XTAL_OUT	Input		Parallel resonant crystal interface. XTAL_OUT is the output, XTAL_IN is the input.
3	MR/nOE	Input	Pulldown	Active HIGH master reset. Active LOW output enable. When logic HIGH, the internal dividers are reset and the outputs are in high impedance (Hi-Z). When logic LOW, the internal dividers and the outputs are enabled. Asynchronous function. LVCMOS/LVTTL interface levels. See Table 3D.
4, 14, 24, 31	V <sub>DD</sub>	Power		Core supply pins.
5, 6	Q0, nQ0	Output		Differential output pair. HCSL interface levels.
7, 8	Q1, nQ1	Output		Differential output pair. HCSL interface levels.
9, 19, 32	GND	Power		Power supply ground.
10, 11	Q2, nQ2	Output		Differential output pair. HCSL interface levels.
12,13	Q3, nQ3	Output		Differential output pair. HCSL interface levels.
15, 16	Q4, nQ4	Output		Differential output pair. HCSL interface levels.
17, 18	Q5, nQ5	Output		Differential output pair. HCSL interface levels.
20, 21	Q6, nQ6	Output		Differential output pair. HCSL interface levels.
22, 23	Q7, nQ7	Output		Differential output pair. HCSL interface levels.
25	FSEL	Input	Pulldown	Output frequency select pin. LVCMOS/LVTTL interface levels. See Table 3B.
26	IREF	Output		HCSL current reference resistor output. An external fixed precision resistor (475Ω) from this pin to ground provides a reference current used for differential current-mode Q <sub>x</sub> , nQ <sub>x</sub> clock outputs.
27	BYPASS	Input	Pulldown	Selects PLL operation/PLL bypass operation. Asynchronous function. LVCMOS/LVTTL interface levels. See Table 3C.
28	V <sub>DDA</sub>	Power		Analog supply pin.
29	REF_SEL	Input	Pulldown	Reference select. Selects the input reference source. LVCMOS/LVTTL interface levels. See Table 3A.
30	REF_IN	Input	Pulldown	LVCMOS/LVTTL PLL reference clock input.

NOTE: *Pulldown* refers to internal input resistors. See Table 2, *Pin Characteristics*, for typical values.

**Table 2. Pin Characteristics**

Symbol	Parameter	Test Conditions	Minimum	Typical	Maximum	Units
C <sub>IN</sub>	Input Capacitance			4		pF
R <sub>PULLDOWN</sub>	Input Pulldown Resistor			51		kΩ

## Function Tables

**Table 3A. REF\_SEL Function Table**

Input	
REF_SEL	Input Reference
0	XTAL (default)
1	REF_IN

**Table 3B. FSEL Function Table ( $f_{REF} = 25\text{MHz}$ )**

Inputs		Outputs
FSEL	N Divider	Q[0:7], nQ[0:7]
0	5	VCO/5 (100MHz) PCIe (default)
1	4	VCO/4 (125MHz) sRIO

**Table 3C. BYPASS Function Table**

Input	
BYPASS	PLL Configuration
0	PLL enabled (default)
1	PLL bypassed ( $f_{OUT} = f_{REF}/N$ )

**Table 3D. MR/nOE Function Table**

Inputs	
MR/nOE	Function
0	Outputs enabled (default)
1	Device reset, outputs disabled (high-impedance)

## Absolute Maximum Ratings

NOTE: Stresses beyond those listed under *Absolute Maximum Ratings* may cause permanent damage to the device. These ratings are stress specifications only. Functional operation of product at these conditions or any conditions beyond those listed in the *DC Characteristics* or *AC Characteristics* is not implied. Exposure to absolute maximum rating conditions for extended periods may affect product reliability.

Item	Rating
Supply Voltage, $V_{DD}$	4.6V
Inputs, $V_I$	-0.5V to $V_{DD} + 0.5V$
Outputs, $V_O$	-0.5V to $V_{DD} + 0.5V$
Package Thermal Impedance, $\theta_{JA}$	37°C/W (0 mps)
Storage Temperature, $T_{STG}$	-65°C to 150°C

## DC Electrical Characteristics

**Table 4A. Power Supply DC Characteristics,  $V_{DD} = 3.3V \pm 5\%$ ,  $T_A = -40^\circ C$  to  $85^\circ C$**

Symbol	Parameter	Test Conditions	Minimum	Typical	Maximum	Units
$V_{DD}$	Core Supply Voltage		3.135	3.3	3.465	V
$V_{DDA}$	Analog Supply Voltage		$V_{DD} - 0.15$	3.3	$V_{DD}$	V
$I_{DD}$	Power Supply Current				87	mA
$I_{DDA}$	Analog Supply Current				15	mA

**Table 4B. LVCMOS/LVTTL DC Characteristics,  $V_{DD} = 3.3V \pm 5\%$ ,  $T_A = -40^\circ C$  to  $85^\circ C$**

Symbol	Parameter	Test Conditions	Minimum	Typical	Maximum	Units
$V_{IH}$	Input High Voltage		2		$V_{DD} + 0.3$	V
$V_{IL}$	Input Low Voltage		-0.3		0.8	V
$I_{IH}$	Input High Current	REF_IN, REF_SEL, BYPASS, FSEL, MR/nOE $V_{DD} = V_{IN} = 3.465V$			150	$\mu A$
$I_{IL}$	Input Low Current	REF_IN, REF_SEL, BYPASS, FSEL, MR/nOE $V_{DD} = 3.465V, V_{IN} = 0V$	-5			$\mu A$

**Table 5. Crystal Characteristics**

Parameter	Test Conditions	Minimum	Typical	Maximum	Units
Mode of Oscillation		Fundamental			
Frequency			25		MHz
Equivalent Series Resistance (ESR)				50	$\Omega$
Shunt Capacitance				7	pF

NOTE: Characterized using an 18pF parallel resonant crystal.

## AC Electrical Characteristics

**Table 6B. AC Characteristics,  $V_{DD} = 3.3V \pm 5\%$ ,  $T_A = -40^\circ C$  to  $85^\circ C$** 

Symbol	Parameter	Test Conditions	Minimum	Typical	Maximum	Units
$f_{MAX}$	Output Frequency	VCO/5		100		MHz
		VCO/4		125		MHz
$f_{jit}(\emptyset)$	RMS Phase Jitter (Random); NOTE 1	100MHz (1.875MHz – 20MHz)		0.39		ps
		125MHz (1.875MHz – 20MHz)		0.37		ps
$t_j$	Phase Jitter Peak-to-Peak; NOTE 2	100MHz, (1.2MHz – 50MHz 10 <sup>6</sup> Samples, 25MHz Crystal Input		24.36		ps
		125MHz, (1.2MHz – 62.5MHz 10 <sup>6</sup> Samples, 25MHz Crystal Input		23.76		ps
$t_{REFCLK\_HF\_RMS}$	Phase Jitter RMS; NOTE 3	100MHz, 10 <sup>6</sup> Samples, 25MHz Crystal Input		2.44		ps
		125MHz, 10 <sup>6</sup> Samples, 25MHz Crystal Input		2.37		ps
$f_{jit}(cc)$	Cycle-to-Cycle Jitter; NOTE 4				50	ps
$t_{sk}(o)$	Output Skew; NOTE 4, 5				105	ps
Rise Edge Rate	Rising Edge Rate; NOTE 6, 7		0.6		4	V/ns
Fall Edge Rate	Falling Edge Rate; NOTE 6, 7		0.6		4	V/ns
$V_{RB}$	Ringback Voltage; NOTE 6, 8		-100		100	mV
$V_{MAX}$	Absolute Maximum Output Voltage; NOTE 9, 10				1150	mV
$V_{MIN}$	Absolute Minimum Output Voltage; NOTE 9, 11		-300			mV
$V_{CROSS}$	Absolute Crossing Voltage; NOTE 9, 12, 13		250		550	mV
$\Delta V_{CROSS}$	Total Variation of $V_{CROSS}$ ; NOTE 9, 12, 14				140	mV
odc	Output Duty Cycle; NOTE 6, 15		48		52	%
$t_{STABLE}$	Power-up Stable Clock Output; NOTE 6, 8		500			ps
$t_L$	PLL Lock Time				90	ms

NOTE: All specifications are taken at 100MHz and 125MHz.

NOTE 1: Refer to the Phase Noise Plot.

NOTE 2: RMS jitter after applying system transfer function. See IDT Application Note, *PCI Express Reference Clock Requirements*. Maximum limit for PCI Express is 86ps peak-to-peak.

NOTE 3: RMS jitter after applying system transfer function. The pole frequencies for H1 and H2 for PCIe Gen 2 are 8-16MHz and 5-16MHz. See IDT Application Note, *PCI Express Reference Clock Requirements*. Maximum limit for PCI Express Generation 2 is 3.1ps RMS.

NOTE 4: This parameter is defined in accordance with JEDEC Standard 65.

NOTE 5: Defined as skew between outputs at the same supply voltage and with equal load conditions. Measured at the output differential cross points.

NOTE 6: Measurement taken from a differential waveform.

NOTE 7: Measured from -150mV to +150mV on the differential waveform (derived from Qx minus nQx). The signal must be monotonic through the measurement region for rise and fall time. The 300mV measurement window is centered on the differential zero crossing.

See Parameter Measurement Information Section.

NOTE 8:  $T_{STABLE}$  is the time the differential clock must maintain a minimum  $\pm 150mV$  differential voltage after rising/falling edges before it is allowed to drop back into the  $V_{RB} \pm 100$  differential range. See Parameter Measurement Information Section.

NOTE 9: Measurement taken from a single-ended waveform.

NOTE 10: Defined as the maximum instantaneous voltage including overshoot. See Parameter Measurement Information Section.

NOTE 11: Defined as the minimum instantaneous voltage including undershoot. See Parameter Measurement Information Section.

NOTE 12: Measured at crossing point where the instantaneous voltage value of the rising edge of Qx equals the falling edge of nQx. See Parameter Measurement Information Section.

NOTE 13: Refers to the total variation from the lowest crossing point to the highest, regardless of which edge is crossing. Refers to all crossing points for this measurement. See Parameter Measurement Information Section.

NOTE 14: Defined as the total variation of all crossing voltage of rising Qx and falling nQx. This is the maximum allowed variance in the  $V_{CROSS}$  for any particular system. See Parameter Measurement Information Section.

NOTE 15: Input duty cycle must be 50%.

### Typical Phase Noise at 100MHz

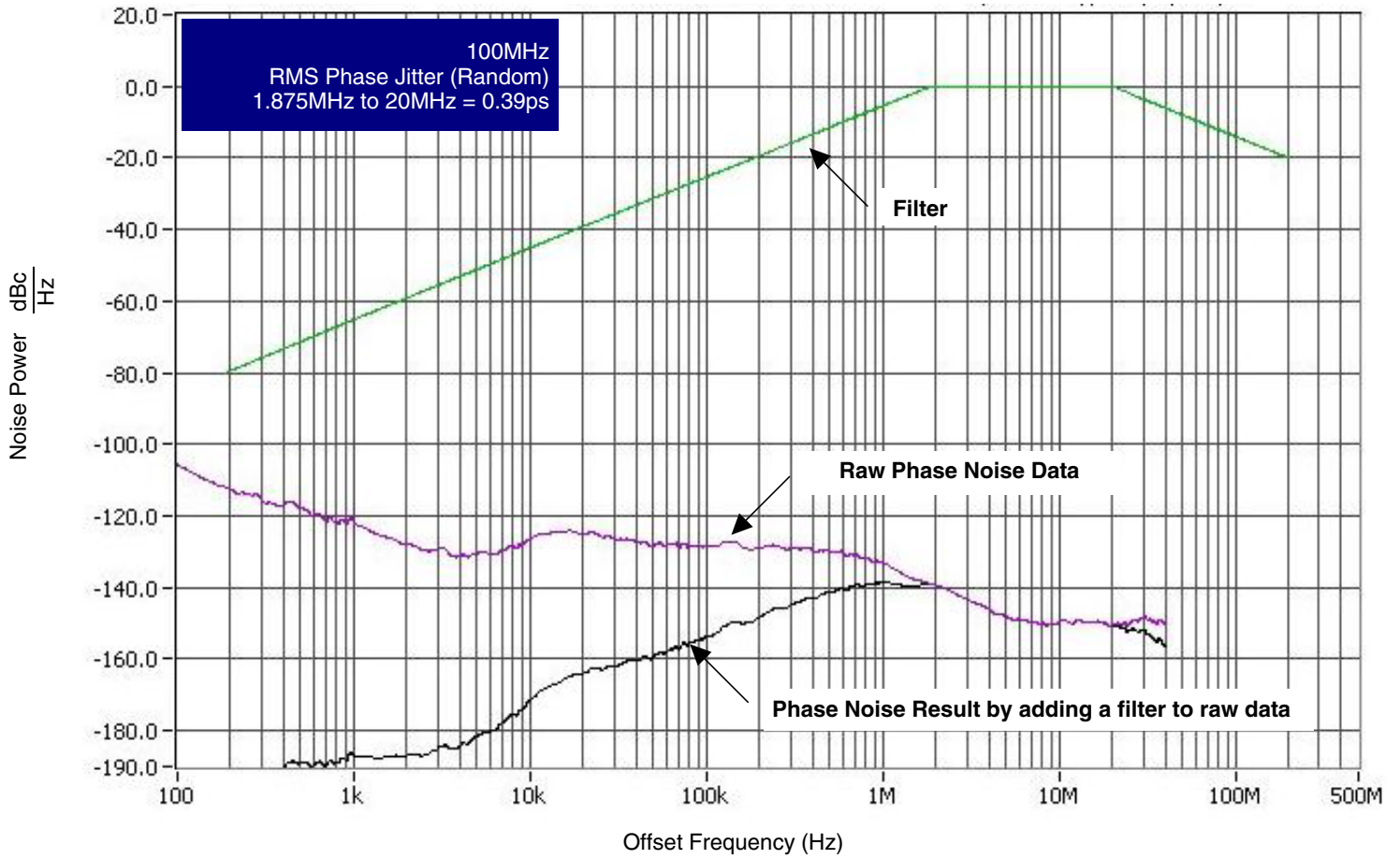

### Typical Phase Noise at 125MHz

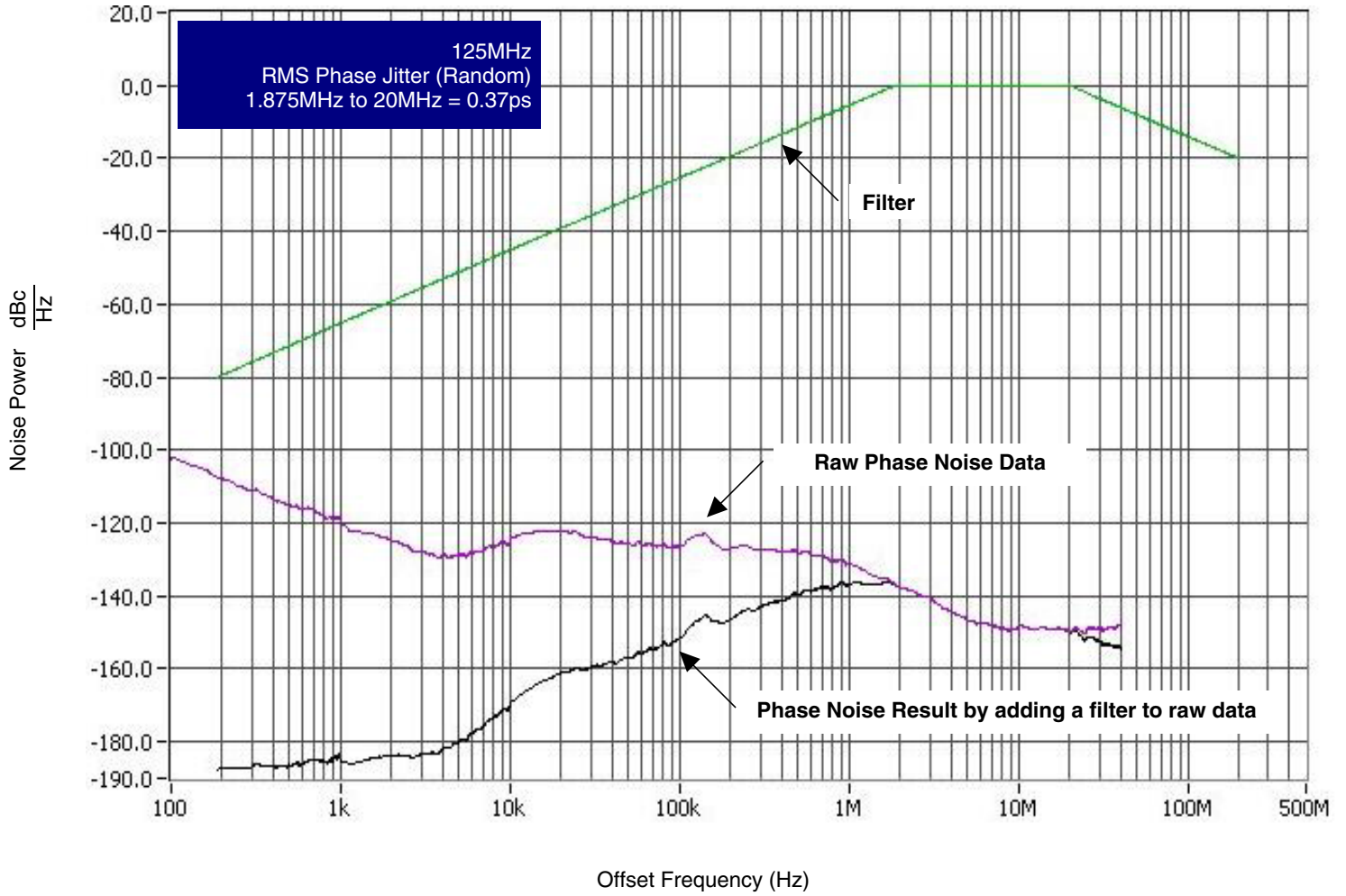

### Parameter Measurement Information

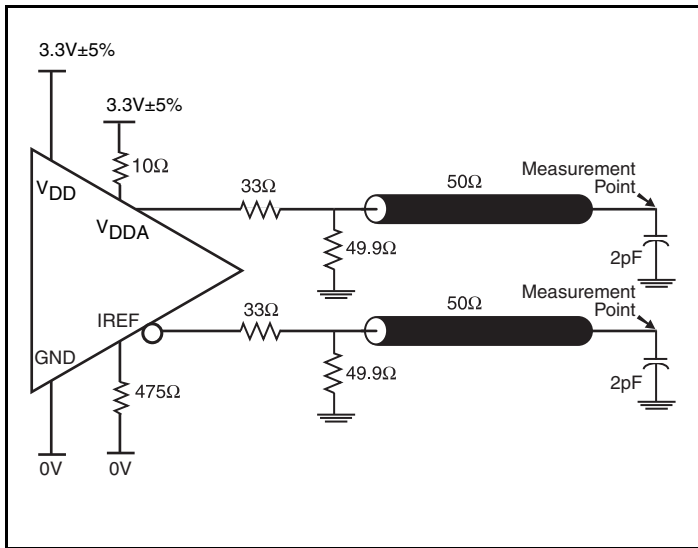

3.3V HCSL Output Load AC Test Circuit

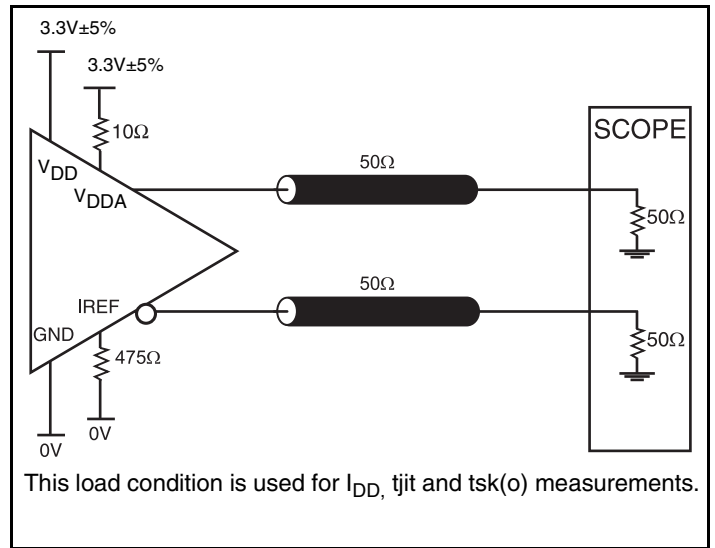

This load condition is used for I<sub>DD</sub>, t<sub>jit</sub> and t<sub>sk(o)</sub> measurements.

3.3V HCSL Output Load AC Test Circuit

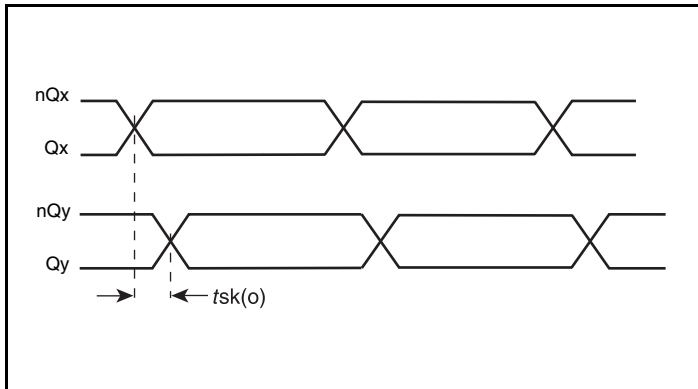

Output Skew

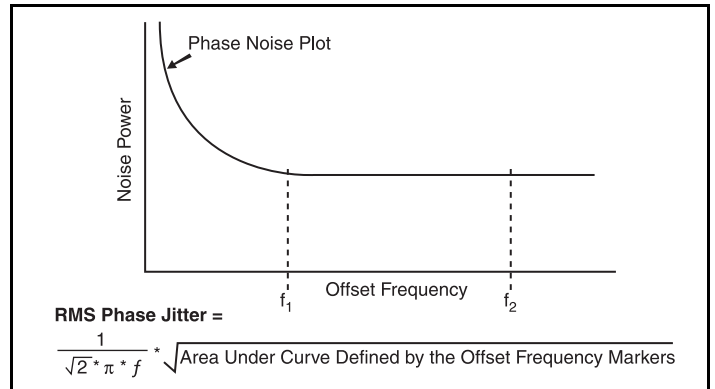

RMS Phase Jitter

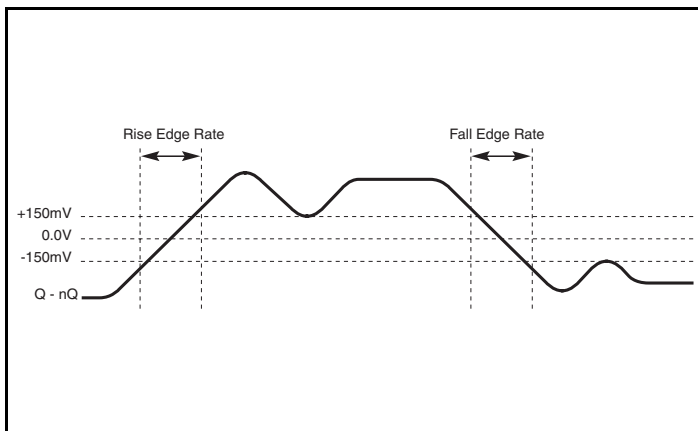

Differential Measurement Points for Rise/Fall Time

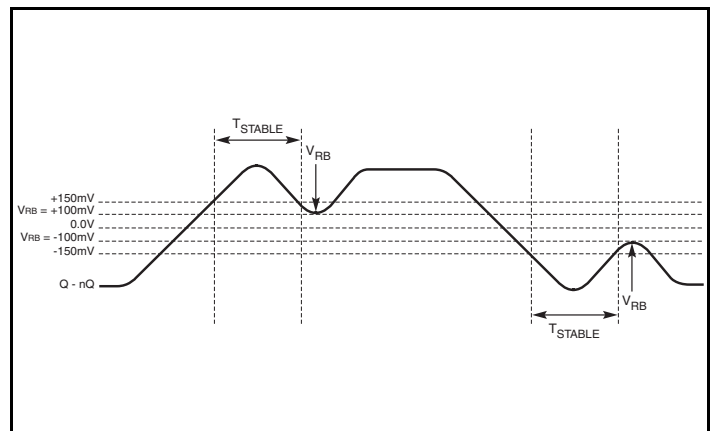

Differential Measurement Points for Ringback

## Parameter Measurement Information, continued

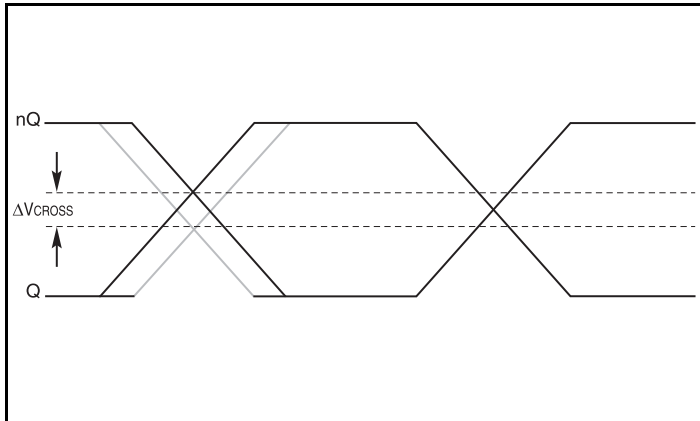

Single-ended Measurement Points for Delta Cross Point

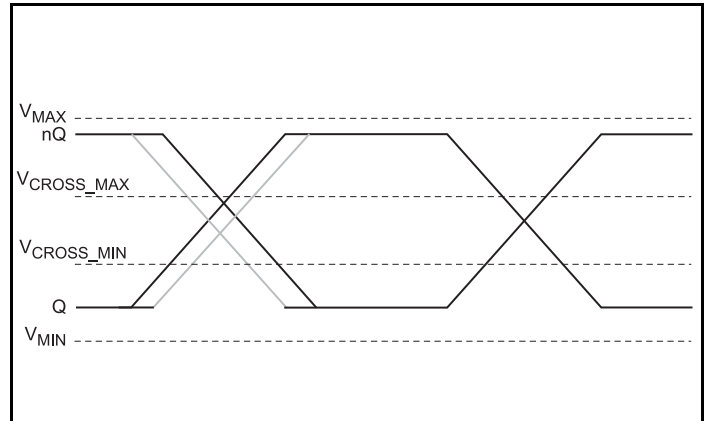

Single-ended Measurement Points for Absolute Cross Point/Swing

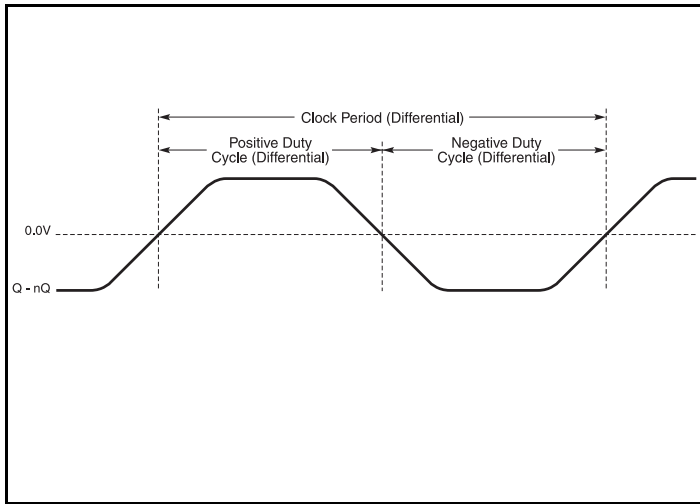

Differential Measurement Points for Duty Cycle/Period

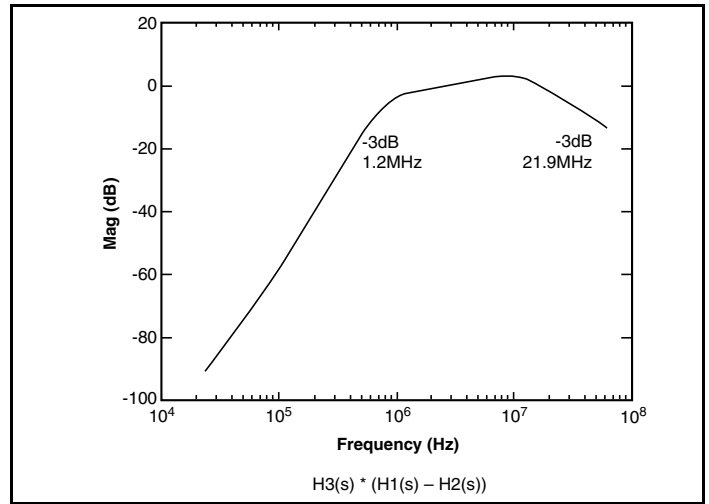

Composite PCIe Transfer Function

## Applications Information

### Recommendations for Unused Input and Output Pins

#### Inputs:

##### Crystal Inputs

For applications not requiring the use of the crystal oscillator input, both XTAL\_IN and XTAL\_OUT can be left floating. Though not required, but for additional protection, a 1k $\Omega$  resistor can be tied from XTAL\_IN to ground.

##### LVC MOS Control Pins

All control pins have internal pulldowns; additional resistance is not required but can be added for additional protection. A 1k $\Omega$  resistor can be used.

##### REF\_IN Input

For applications not requiring the use of the reference clock, it can be left floating. Though not required, but for additional protection, a 1k $\Omega$  resistor can be tied from the REF\_IN to ground.

#### Outputs:

##### HCSL Outputs

All unused HCSL outputs can be left floating. We recommend that there is no trace attached. Both sides of the differential output pair should either be left floating or terminated.

### Power Supply Filtering Technique

As in any high speed analog circuitry, the power supply pins are vulnerable to random noise. To achieve optimum jitter performance, power supply isolation is required. The 841608 provides separate power supplies to isolate any high switching noise from the outputs to the internal PLL.  $V_{DD}$  and  $V_{DDA}$  should be individually connected to the power supply plane through vias, and 0.01 $\mu$ F bypass capacitors should be used for each pin. *Figure 1* illustrates this for a generic  $V_{DD}$  pin and also shows that  $V_{DDA}$  requires that an additional 10 $\Omega$  resistor along with a 10 $\mu$ F bypass capacitor be connected to the  $V_{DDA}$  pin.

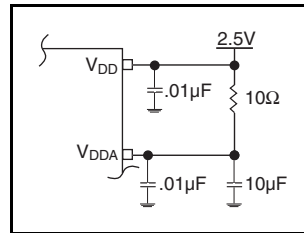

**Figure 1. Power Supply Filtering**

### Crystal Input Interface

The 841608 has been characterized with 18pF parallel resonant crystals. The capacitor values shown in Figure 2 below were determined using a 25MHz, 18pF parallel resonant crystal and were chosen to minimize the ppm error.



Figure 2. Crystal Input Interface

### LVC MOS to XTAL Interface

The XTAL\_IN input can accept a single-ended LVC MOS signal through an AC coupler capacitor. A general interface diagram is shown in Figure 3. The XTAL\_OUT pin can be left floating. The input edge rate can be as slow as 10ns. For LVC MOS inputs, it is recommended that the amplitude be reduced from full swing to half swing in order to prevent signal interference with the power rail and to reduce noise. This configuration requires that the output

impedance of the driver ( $R_o$ ) plus the series resistance ( $R_s$ ) equals the transmission line impedance. In addition, matched termination at the crystal input will attenuate the signal in half. This can be done in one of two ways. First,  $R_1$  and  $R_2$  in parallel should equal the transmission line impedance. For most 50Ω applications,  $R_1$  and  $R_2$  can be 100Ω. This can also be accomplished by removing  $R_1$  and making  $R_2$  50Ω.

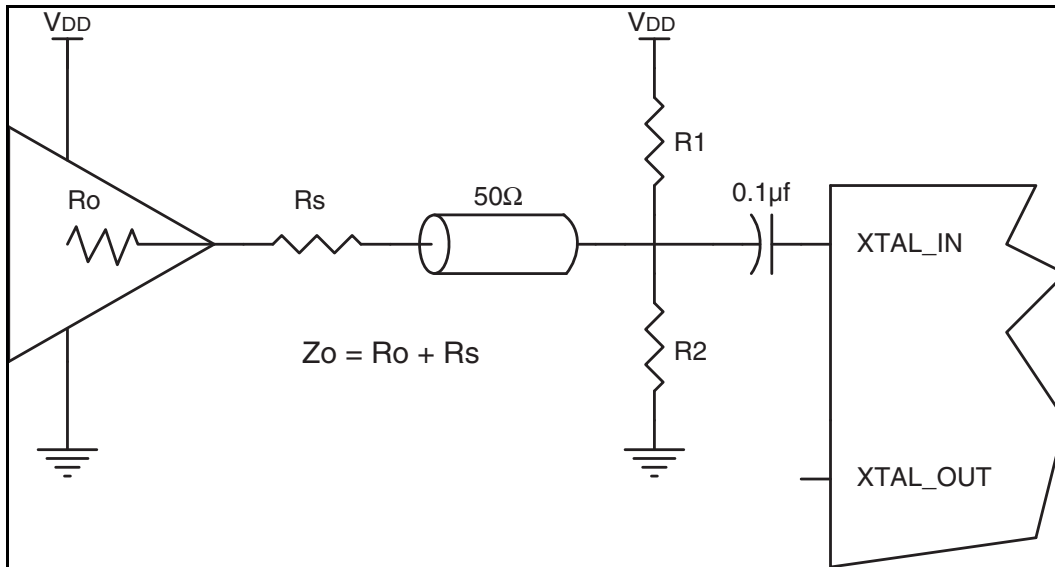

Figure 3. General Diagram for LVC MOS Driver to XTAL Input Interface

### Recommended Termination

Figure 4A is the recommended termination for applications which require the receiver and driver to be on a separate PCB. All traces should be 50Ω impedance.

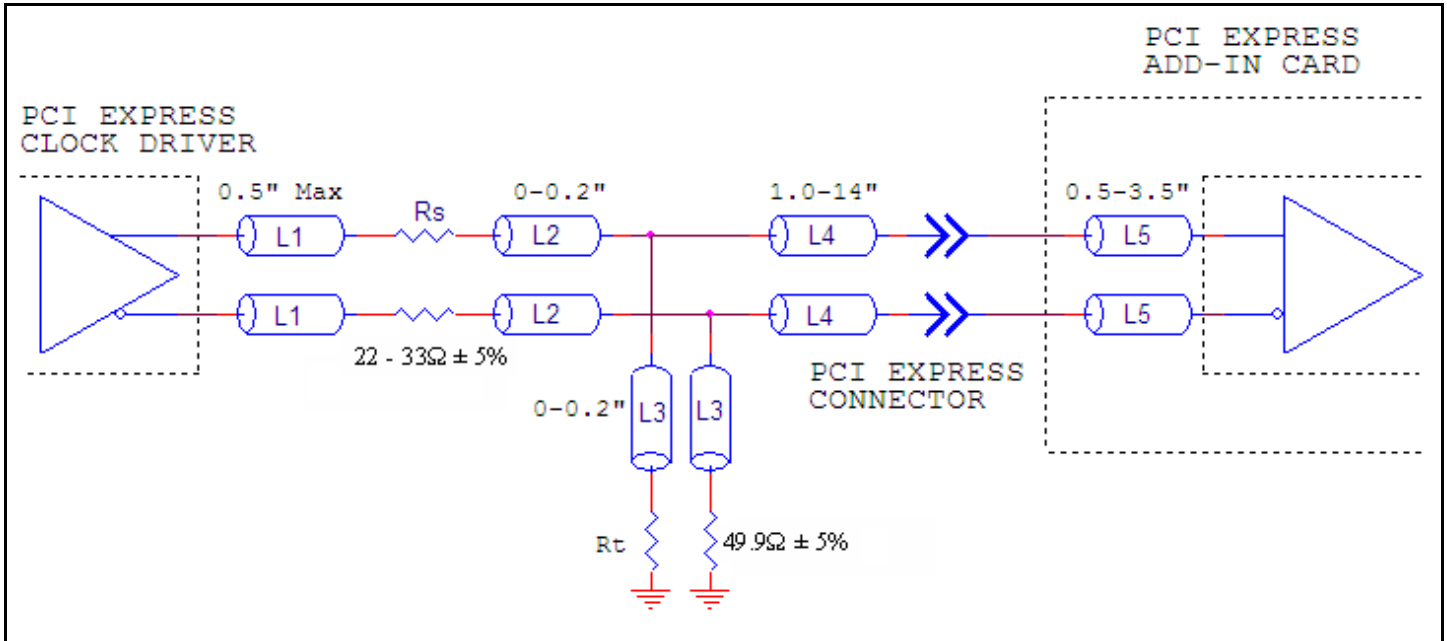

Figure 4A. Recommended Termination

Figure 4B is the recommended termination for applications which require a point to point connection and contain the driver and receiver on the same PCB. All traces should all be 50Ω impedance.

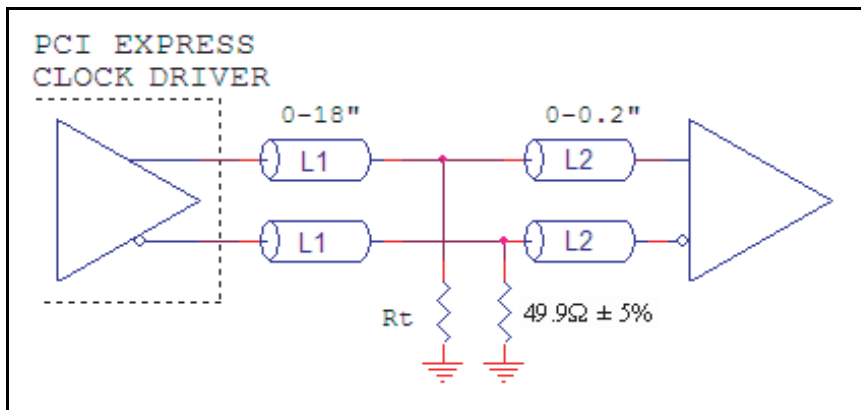

Figure 4A. Recommended Termination

### VFQFN EPAD Thermal Release Path

In order to maximize both the removal of heat from the package and the electrical performance, a land pattern must be incorporated on the Printed Circuit Board (PCB) within the footprint of the package corresponding to the exposed metal pad or exposed heat slug on the package, as shown in *Figure 5*. The solderable area on the PCB, as defined by the solder mask, should be at least the same size/shape as the exposed pad/slug area on the package to maximize the thermal/electrical performance. Sufficient clearance should be designed on the PCB between the outer edges of the land pattern and the inner edges of pad pattern for the leads to avoid any shorts.

While the land pattern on the PCB provides a means of heat transfer and electrical grounding from the package to the board through a solder joint, thermal vias are necessary to effectively conduct from the surface of the PCB to the ground plane(s). The land pattern must be connected to ground through these vias. The vias act as “heat pipes”. The number of vias (i.e. “heat pipes”) are application specific

and dependent upon the package power dissipation as well as electrical conductivity requirements. Thus, thermal and electrical analysis and/or testing are recommended to determine the minimum number needed. Maximum thermal and electrical performance is achieved when an array of vias is incorporated in the land pattern. It is recommended to use as many vias connected to ground as possible. It is also recommended that the via diameter should be 12 to 13mils (0.30 to 0.33mm) with 1oz copper via barrel plating. This is desirable to avoid any solder wicking inside the via during the soldering process which may result in voids in solder between the exposed pad/slug and the thermal land. Precautions should be taken to eliminate any solder voids between the exposed heat slug and the land pattern. Note: These recommendations are to be used as a guideline only. For further information, please refer to the Application Note on the Surface Mount Assembly of Amkor’s Thermally/Electrically Enhance Leadframe Base Package, Amkor Technology.

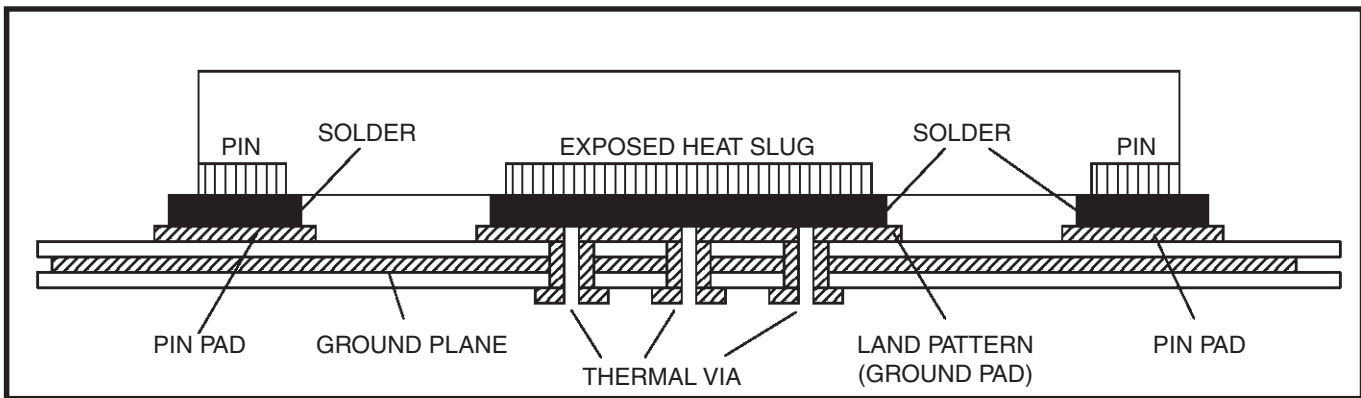

**Figure 5. P.C. Assembly for Exposed Pad Thermal Release Path – Side View (drawing not to scale)**

## Schematic Example

Figure 6 shows an example of 841608 application schematic. In this example, the device is operated at  $V_{DD} = 3.3V$ . The 18pF parallel resonant 25MHz crystal is used. The  $C1 = 27pF$  and  $C2 = 27pF$  are recommended for frequency accuracy. For different board layout, the

$C1$  and  $C2$  may be slightly adjusted for optimizing frequency accuracy. Two examples of HCSL terminations are shown in this schematic. The decoupling capacitors should be located as close as possible to the power pin.

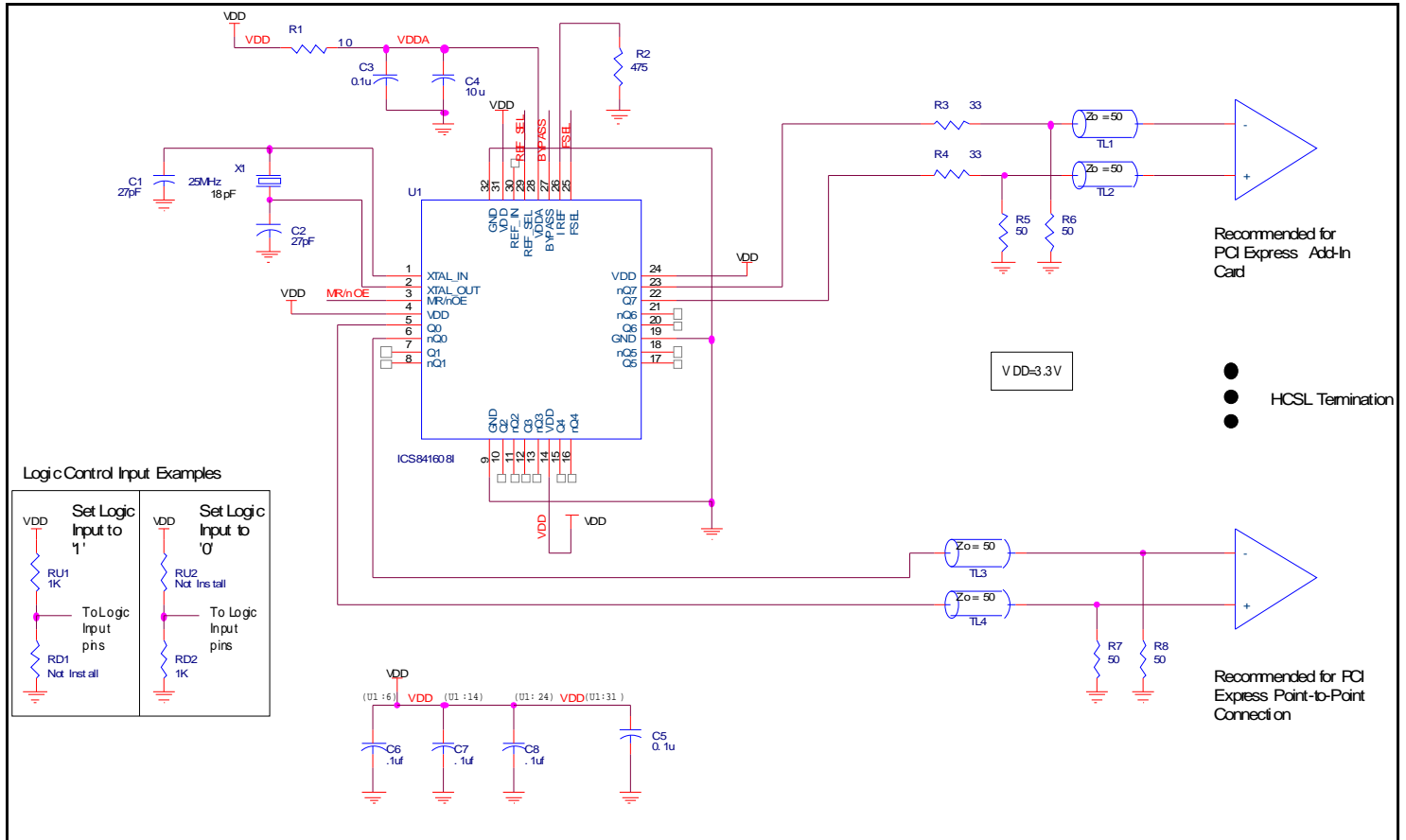

Figure 6. 841608 Application Schematic

## Power Considerations

This section provides information on power dissipation and junction temperature for the 841608. Equations and example calculations are also provided.

### 1. Power Dissipation.

The total power dissipation for the 841608 is the sum of the core power plus the analog power plus the power dissipation in the load(s). The following is the power dissipation for  $V_{DD} = 3.3V + 5\% = 3.465V$ , which gives worst case results.

NOTE: Please refer to Section 3 for details on calculating power dissipation in the load.

- Power (core)<sub>MAX</sub> =  $V_{DD\_MAX} * (I_{DD\_MAX} + I_{DDA\_MAX}) = 3.465V * (87mA + 15mA) = \mathbf{353.43mW}$
- Power (outputs)<sub>MAX</sub> = **44.5mW/Loaded Output pair**  
If all outputs are loaded, the total power is  $8 * 44.5mW = \mathbf{356mW}$

**Total Power<sub>MAX</sub>** = (3.465V, with all outputs switching) =  $353.43mW + 356mW = \mathbf{709.43mW}$

### 2. Junction Temperature.

Junction temperature,  $T_j$ , is the temperature at the junction of the bond wire and bond pad, and directly affects the reliability of the device. The maximum recommended junction temperature for devices is 125°C.

The equation for  $T_j$  is as follows:  $T_j = \theta_{JA} * Pd\_total + T_A$

$T_j$  = Junction Temperature

$\theta_{JA}$  = Junction-to-Ambient Thermal Resistance

$Pd\_total$  = Total Device Power Dissipation (example calculation is in section 1 above)

$T_A$  = Ambient Temperature

In order to calculate junction temperature, the appropriate junction-to-ambient thermal resistance  $\theta_{JA}$  must be used. Assuming no air flow and a multi-layer board, the appropriate value is 37°C/W per Table 7 below.

Therefore,  $T_j$  for an ambient temperature of 85°C with all outputs switching is:

$$85^\circ\text{C} + 0.709\text{W} * 37^\circ\text{C/W} = 111.2^\circ\text{C}. \text{ This is well below the limit of } 125^\circ\text{C}.$$

This calculation is only an example.  $T_j$  will obviously vary depending on the number of loaded outputs, supply voltage, air flow and the type of board (multi-layer).

**Table 7. Thermal Resistance  $\theta_{JA}$  for 32-Pin VFQFN, Forced Convection**

$\theta_{JA}$ vs. Air Flow			
Meters per Second	0	1	2.5
Multi-Layer PCB, JEDEC Standard Test Boards	37.0°C/W	32.4°C/W	29.0°C/W

### 3. Calculations and Equations.

The purpose of this section is to calculate power dissipation on the IC per HCSL output pair.

HCSL output driver circuit and termination are shown in *Figure 7*.

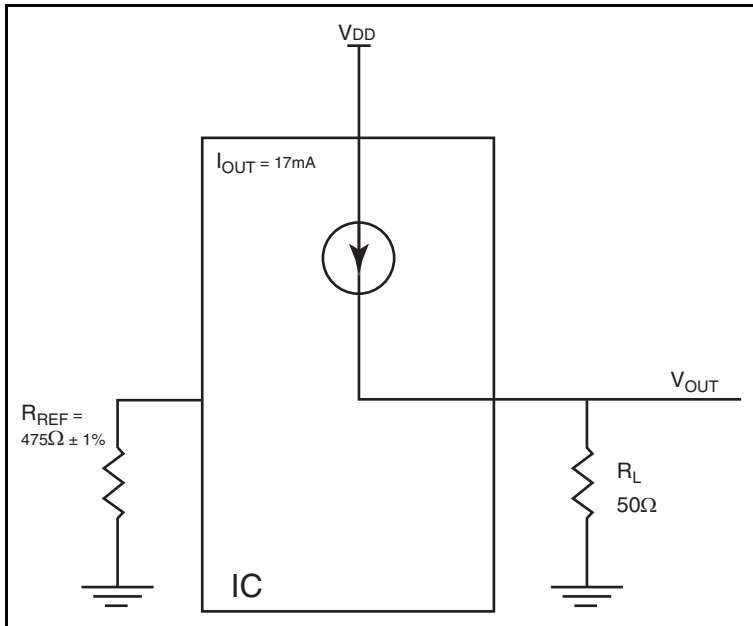

**Figure 7. HCSL Driver Circuit and Termination**

HCSL is a current steering output which sources a maximum of 17mA of current per output. To calculate worst case on-chip power dissipation, use the following equations which assume a 50Ω load to ground.

The highest power dissipation occurs when  $V_{DD}$  is HIGH.

$$\begin{aligned}
 \text{Power} &= (V_{DD\_HIGH} - V_{OUT}) * I_{OUT}, \text{ since } V_{OUT} = I_{OUT} * R_L \\
 &= (V_{DD\_HIGH} - I_{OUT} * R_L) * I_{OUT} \\
 &= (3.465V - 17mA * 50\Omega) * 17mA
 \end{aligned}$$

Total Power Dissipation per output pair = **44.5mW**

## Reliability Information

**Table 8.  $\theta_{JA}$  vs. Air Flow Table for a 32 Lead VFQFN**

$\theta_{JA}$ vs. Air Flow			
Meters per Second	<b>0</b>	<b>1</b>	<b>2.5</b>
Multi-Layer PCB, JEDEC Standard Test Boards	37.0°C/W	32.4°C/W	29.0°C/W

## Transistor Count

The transistor count for 841608 is: 2785

### 32-Lead VFQFN Package Outline and Package Dimensions

REVISIONS			
REV	DESCRIPTION	DATE	APPROVED
00	INITIAL RELEASE	2/1/16	JH
01	ADD "k" VALUE MIN 0.20	2/8/16	JH

SYMBOL	DIMENSION		
	MIN	NOM	MAX
b	0.18	0.25	0.30
D	5.00 BSC		
E	5.00 BSC		
D2	3.00	3.15	3.30
E2	3.00	3.15	3.30
L	0.30	0.40	0.50
e	0.50 BSC		
N	32		
A	0.80	0.90	1.00
A1	0.00	0.02	0.05
A3	0.2 REF		
k	0.20	10:53 REF	

TOP VIEW

SIDE VIEW

BOTTOM VIEW

PIN #1 ID OPTION

NOTES:

- ALL DIMENSIONS ARE IN mm; ANGLES IN DEGREES.
- COPLANARITY APPLIES TO THE EXPOSED PAD AS WELL AS THE TERMINALS.  
COPLANARITY SHALL NOT EXCEED 0.08 mm.
- WARPAGE SHALL NOT EXCEED 0.10 mm.

TOLERANCES UNLESS SPECIFIED DECIMAL X± 1 XXX± .05 XXX± .030	6024 Silver Creek Valley Rd San Jose, CA 95138 PHONE: (408) 284-8200 FAX: (408) 284-3572 www.IDT.com	TITLE NL/NLG 32 PACKAGE OUTLINE 5.0 x 5.0 mm BODY EPAD 3.15 x 3.15 0.50 mm PITCH QFN
APPROVALS DRAWN /BAG CHECKED	DATE 2/1/16	SIZE DRAWING No. C PSC-4171-01
DO NOT SCALE DRAWING		SHEET 1 OF 2

### 32-Lead VFQFN Package Outline and Package Dimensions

REVISIONS			
REV	DESCRIPTION	DATE	APPROVED
00	INITIAL RELEASE	2/1/16	JH
01	ADD "k" VALUE MIN 0.20	2/8/16	JH

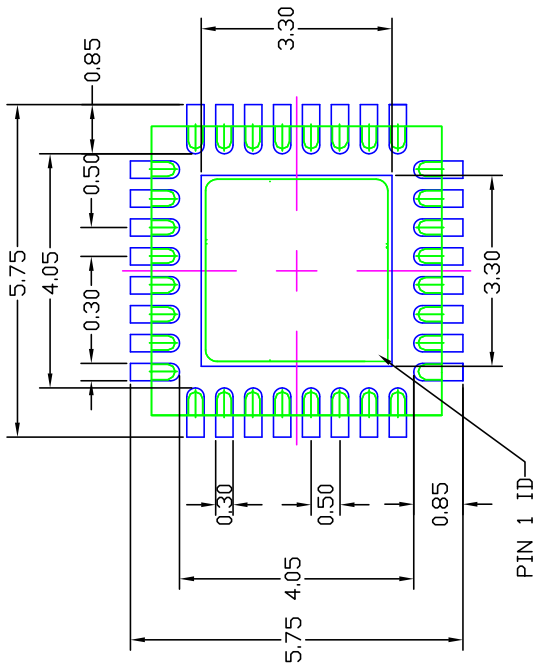

RECOMMENDED LAND PATTERN

NOTES:

1. ALL DIMENSIONS ARE IN mm. ANGLES IN DEGREES.
2. TOP DOWN VIEW, AS VIEWED ON PCB.
3. COMPONENT OUTLINE SHOWS FOR REFERENCE IN GREEN.
4. LAND PATTERN IN BLUE. NSMD PATTERN ASSUMED.
5. LAND PATTERN RECOMMENDATION PER IPC-7351B GENERIC REQUIREMENT FOR SURFACE MOUNT DESIGN AND LAND PATTERN.

<b>TOLERANCES UNLESS SPECIFIED</b> DECIMAL ±.1 XX± .05 XXX± .030		<b>IDT</b> 6024 Silver Creek Valley Rd San Jose, CA 95138 PHONE: (408) 284-8200 FAX: (408) 284-3572 www.IDT.com	
<b>APPROVALS</b> DRAWN <i>046</i> CHECKED	<b>DATE</b> 2/1/16	<b>TITLE</b> NL/NLG 32 PACKAGE OUTLINE 5.0 x 5.0 mm BODY EPAD 3.15 x 3.15 0.50 mm PITCH QFN	
<b>SIZE</b> C <b>DRAWING No.</b> PSC-4171-01		<b>REV</b> 01 <b>DO NOT SCALE DRAWING</b> SHEET 2 OF 2	

## Ordering Information

Table 10. Ordering Information

Part/Order Number	Marking	Package	Shipping Packaging	Temperature
841608AKILF	ICS41608AIL	"Lead-Free", 32 Lead TSSOP	Tray	-40°C to 85°C
841608AKILFT	ICS41608AIL	"Lead-Free", 32 Lead TSSOP	Tape & Reel	-40°C to 85°C

## Revision History Sheet

Rev	Table	Page	Description of Change	Date
B	T10	P19 20	Updated Package Information. Ordering Information Table - deleted tray count and table note. Deleted HiperClocks references through out the datasheet. Deletec "ICS" prefix and "I" suffix in part number. Updated datasheet header/footer.	5/4/2016



Corporate Headquarters  
6024 Silver Creek Valley Road  
San Jose, CA 95138 USA  
[www.IDT.com](http://www.IDT.com)

Sales  
1-800-345-7015 or 408-284-8200  
Fax: 408-284-2775  
[www.IDT.com/go/sales](http://www.IDT.com/go/sales)

Tech Support  
[www.idt.com/go/support](http://www.idt.com/go/support)

DISCLAIMER Integrated Device Technology, Inc. (IDT) reserves the right to modify the products and/or specifications described herein at any time, without notice, at IDT's sole discretion. Performance specifications and operating parameters of the described products are determined in an independent state and are not guaranteed to perform the same way when installed in customer products. The information contained herein is provided without representation or warranty of any kind, whether express or implied, including, but not limited to, the suitability of IDT's products for any particular purpose, an implied warranty of merchantability, or non-infringement of the intellectual property rights of others. This document is presented only as a guide and does not convey any license under intellectual property rights of IDT or any third parties.

IDT's products are not intended for use in applications involving extreme environmental conditions or in life support systems or similar devices where the failure or malfunction of an IDT product can be reasonably expected to significantly affect the health or safety of users. Anyone using an IDT product in such a manner does so at their own risk, absent an express, written agreement by IDT.

Integrated Device Technology, IDT and the IDT logo are trademarks or registered trademarks of IDT and its subsidiaries in the United States and other countries. Other trademarks used herein are the property of IDT or their respective third party owners.

For datasheet type definitions and a glossary of common terms, visit [www.idt.com/go/glossary](http://www.idt.com/go/glossary).

Copyright ©2016 Integrated Device Technology, Inc. All rights reserved.

## Looking for pricing, stock, or lifecycle information?

Click below to explore more details on WIN SOURCE:

- ⊖ [View 841608AKILFT on WIN SOURCE](#)
- ⊖ [IDT, Integrated Device Technology Inc Information](#)

## Optimize Your Supply Chain with WIN SOURCE Solutions

- ✓ Global Sourcing Solution
- ✓ Obsolete Management
- ✓ Cost Control Management
- ✓ Shortage Management
- ✓ Alternative Solution
- ✓ Excess Inventory Management