



**THE DATASHEET OF
843002AGLFT**



GENERAL DESCRIPTION

The 843002 is a two output LVPECL synthesizer optimized to generate Fibre Channel reference clock frequencies. Using a 26.5625MHz, 18pF parallel resonant crystal, the following frequencies can be generated based on the 2 frequency select pins (F_SEL[1:0]): 212.5MHz, 187.5MHz, 159.375MHz, 106.25MHz, and 53.125MHz. The 843002 uses IDT's 3rd generation low phase noise VCO technology and can achieve 1ps or lower typical rms phase jitter, easily meeting Fibre Channel jitter requirements. The 843002 is packaged in a small 20-pin TSSOP package.

FEATURES

- Two 3.3V LVPECL outputs
- Selectable crystal oscillator interface or LVCMOS/LVTTL single-ended input
- Supports the following output frequencies: 212.5MHz, 187.5MHz, 159.375MHz, 106.25MHz and 53.125MHz
- VCO range: 560MHz - 680MHz
- RMS phase jitter (637kHz - 10MHz): 0.72ps (typical)
- Typical phase noise at 212.5MHz

| Offset | Noise Power |
|--------|---------------|
| 100Hz | -87.7 dBc/Hz |
| 1KHz | -111.6 dBc/Hz |
| 10KHz | -124.3 dBc/Hz |
| 100KHz | -124.3 dBc/Hz |
- Full 3.3V supply mode
- Lead-Free package RoHS compliant
- -30°C to 85°C ambient operating temperature

FREQUENCY SELECT FUNCTION TABLE

| Inputs | | | | | | Output Frequency (MHz) |
|-----------------------|--------|--------|-----------------|-----------------|-------------------|------------------------|
| Input Frequency (MHz) | F_SEL1 | F_SEL0 | M Divider Value | N Divider Value | M/N Divider Value | |
| 26.5625 | 0 | 0 | 24 | 3 | 8 | 212.5 |
| 26.5625 | 0 | 1 | 24 | 4 | 6 | 159.375 |
| 26.5625 | 1 | 0 | 24 | 6 | 4 | 106.25 |
| 26.5625 | 1 | 1 | 24 | 12 | 2 | 53.125 |
| 23.4375 | 0 | 0 | 24 | 3 | 8 | 187.5 |

PIN ASSIGNMENT

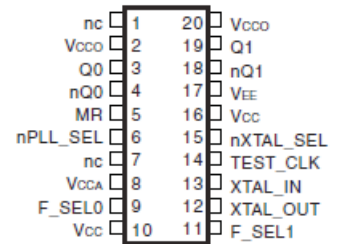

843002

20-Lead TSSOP

6.5mm x 4.4mm x 0.92mm
package body

G Package

Top View

BLOCK DIAGRAM

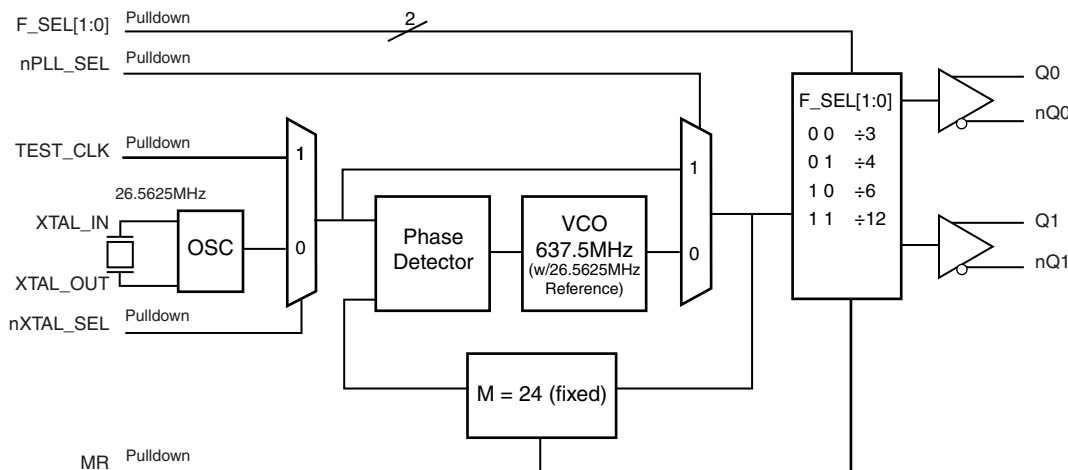

TABLE 1. PIN DESCRIPTIONS

| Number | Name | Type | | Description |
|--------|----------------------|--------|----------|---|
| 1, 7 | nc | Unused | | No connect. |
| 2, 20 | V _{CCO} | Power | | Output supply pins. |
| 3, 4 | Q0, nQ0 | Output | | Differential output pair. LVPECL interface levels. |
| 5 | MR | Input | Pulldown | Active HIGH Master Reset. When logic HIGH, the internal dividers are reset causing the true outputs Qx to go low and the inverted outputs nQx to go high. When logic LOW, the internal dividers and the outputs are enabled. LVCMOS/LVTTL interface levels. |
| 6 | nPLL_SEL | Input | Pulldown | Selects between the PLL and TEST_CLK as input to the dividers. When LOW, selects PLL (PLL Enable). When HIGH, deselects the reference clock (PLL Bypass). LVCMOS/LVTTL interface levels. |
| 8 | V _{CCA} | Power | | Analog supply pin. |
| 9, 11 | F_SEL0, F_SEL1 | Input | Pulldown | Frequency select pins. LVCMOS/LVTTL interface levels. |
| 10, 16 | V _{CC} | Power | | Core supply pin. |
| 12, 13 | XTAL_OUT, XTAL_IN | Input | | Parallel resonant crystal interface. XTAL_OUT is the output, XTAL_IN is the input. |
| 14 | TEST_CLK | Input | Pulldown | LVCMOS/LVTTL clock input. |
| 15 | nXTAL_SEL | Input | Pulldown | Selects between crystal or TEST_CLK inputs as the the PLL Reference source. Selects XTAL inputs when LOW. Selects TEST_CLK when HIGH. LVCMOS/LVTTL interface levels. |
| 17 | V _{EE} | Power | | Negative supply pins. |
| 18, 19 | nQ1, Q1 | Output | | Differential output pair. LVPECL interface levels. |

NOTE: *Pulldown* refer to internal input resistors. See Table 2, Pin Characteristics, for typical values.

TABLE 2. PIN CHARACTERISTICS

| Symbol | Parameter | Test Conditions | Minimum | Typical | Maximum | Units |
|-----------------------|-------------------------|-----------------|---------|---------|---------|-------|
| C _{IN} | Input Capacitance | | | 4 | | pF |
| R _{PULLDOWN} | Input Pulldown Resistor | | | 51 | | kΩ |

ABSOLUTE MAXIMUM RATINGS

| | |
|--|--------------------------|
| Supply Voltage, V_{CC} | 4.6V |
| Inputs, V_I | -0.5V to $V_{CC} + 0.5V$ |
| Outputs, I_O | |
| Continuous Current | 50mA |
| Surge Current | 100mA |
| Package Thermal Impedance, θ_{JA} | 73.2°C/W (0 lfpm) |
| Storage Temperature, T_{STG} | -65°C to 150°C |

NOTE: Stresses beyond those listed under Absolute Maximum Ratings may cause permanent damage to the device. These ratings are stress specifications only. Functional operation of product at these conditions or any conditions beyond those listed in the *DC Characteristics* or *AC Characteristics* is not implied. Exposure to absolute maximum rating conditions for extended periods may affect product reliability.

TABLE 3A. POWER SUPPLY DC CHARACTERISTICS, $V_{CC} = V_{CCA} = V_{CCO} = 3.3V \pm 10\%$, $T_A = -30^\circ C$ TO $85^\circ C$

| Symbol | Parameter | Test Conditions | Minimum | Typical | Maximum | Units |
|-----------|-----------------------|-----------------|---------|---------|---------|-------|
| V_{CC} | Core Supply Voltage | | 2.97 | 3.3 | 3.63 | V |
| V_{CCA} | Analog Supply Voltage | | 2.97 | 3.3 | 3.63 | V |
| V_{CCO} | Output Supply Voltage | | 2.97 | 3.3 | 3.63 | V |
| I_{EE} | Power Supply Current | | | | 135 | mA |
| I_{CC} | Core Supply Current | | | | 100 | mA |
| I_{CCA} | Analog Supply Current | | | | 15 | mA |
| I_{CCO} | Output Supply Current | | | | 31 | mA |

TABLE 3B. LVCMOS / LVTTTL DC CHARACTERISTICS, $V_{CC} = V_{CCA} = V_{CCO} = 3.3V \pm 10\%$, $T_A = -30^\circ C$ TO $85^\circ C$

| Symbol | Parameter | Test Conditions | Minimum | Typical | Maximum | Units |
|----------|--------------------|--|---------|---------|----------------|---------|
| V_{IH} | Input High Voltage | | 2 | | $V_{CC} + 0.3$ | V |
| V_{IL} | Input Low Voltage | nPLL_SEL, nXTAL_SEL, F_SEL0, F_SEL1, MR | -0.3 | | 0.8 | V |
| | | TEST_CLK | -0.3 | | 1.0 | V |
| I_{IH} | Input High Current | TEST_CLK, MR, F_SEL0, F_SEL1, nPLL_SEL, nXTAL_SEL, $V_{CC} = V_{IN} = 3.63V$ | | | 150 | μA |
| I_{IL} | Input Low Current | TEST_CLK, MR, F_SEL0, F_SEL1, nPLL_SEL, nXTAL_SEL, $V_{CC} = 3.63V, V_{IN} = 0V$ | -150 | | | μA |

TABLE 3C. LVPECL DC CHARACTERISTICS, $V_{CC} = V_{CCA} = V_{CCO} = 3.3V \pm 10\%$, $T_A = -30^\circ C$ TO $85^\circ C$

| Symbol | Parameter | Test Conditions | Minimum | Typical | Maximum | Units |
|-------------|-----------------------------------|-----------------|-----------------|---------|-----------------|-------|
| V_{OH} | Output High Voltage; NOTE 1 | | $V_{CCO} - 1.4$ | | $V_{CCO} - 0.9$ | V |
| V_{OL} | Output Low Voltage; NOTE 1 | | $V_{CCO} - 2.0$ | | $V_{CCO} - 1.7$ | V |
| V_{SWING} | Peak-to-Peak Output Voltage Swing | | 0.6 | | 1.0 | V |

NOTE 1: Outputs terminated with 50 Ω to $V_{CCO} - 2V$.

TABLE 4. CRYSTAL CHARACTERISTICS

| Parameter | Test Conditions | Minimum | Typical | Maximum | Units |
|------------------------------------|-----------------|-------------|---------|---------|----------|
| Mode of Oscillation | | Fundamental | | | |
| Frequency | | 23.33 | 26.5625 | 28.33 | MHz |
| Equivalent Series Resistance (ESR) | | | | 50 | Ω |
| Shunt Capacitance | | | | 7 | pF |

NOTE: Characterized using an 18pF parallel resonant crystal.

TABLE 5. AC CHARACTERISTICS, $V_{CC} = V_{CCA} = V_{CCO} = 3.3V \pm 10\%$, $T_A = -30^\circ\text{C}$ TO 85°C

| Symbol | Parameter | Test Conditions | Minimum | Typical | Maximum | Units |
|---------------------|--------------------------------------|------------------------------|---------|---------|---------|-------|
| f_{OUT} | Output Frequency | F_SEL[1:0] = 00 | 186.67 | | 226.67 | MHz |
| | | F_SEL[1:0] = 01 | 140 | | 170 | MHz |
| | | F_SEL[1:0] = 10 | 93.33 | | 113.33 | MHz |
| | | F_SEL[1:0] = 11 | 46.67 | | 56.67 | MHz |
| tsk(o) | Output Skew; NOTE 1, 2 | | | 20 | ps | |
| tjit(\emptyset) | RMS Phase Jitter (Random); NOTE 3 | 212.5MHz, (637KHz - 10MHz) | | 0.72 | | ps |
| | | 159.375MHz, (637KHz - 10MHz) | | 0.76 | | ps |
| | | 106.25MHz, (637KHz - 10MHz) | | 0.84 | | ps |
| | | 53.125MHz, (637KHz - 10MHz) | | 0.97 | | ps |
| t_R / t_F | Output Rise/Fall Time | 20% to 80% | 300 | | 600 | ps |
| odc | Output Duty Cycle | F_SEL[1:0] = 00 | 46 | | 54 | % |
| | | F_SEL[1:0] = 01 | 49 | | 51 | % |

NOTE 1: Defined as skew between outputs at the same supply voltages and with equal load conditions. Measured at $V_{CCO}/2$.

NOTE 2: This parameter is defined in accordance with JEDEC Standard 65.

NOTE 3: See Phase Noise plot.

TYPICAL PHASE NOISE AT 53.125MHz

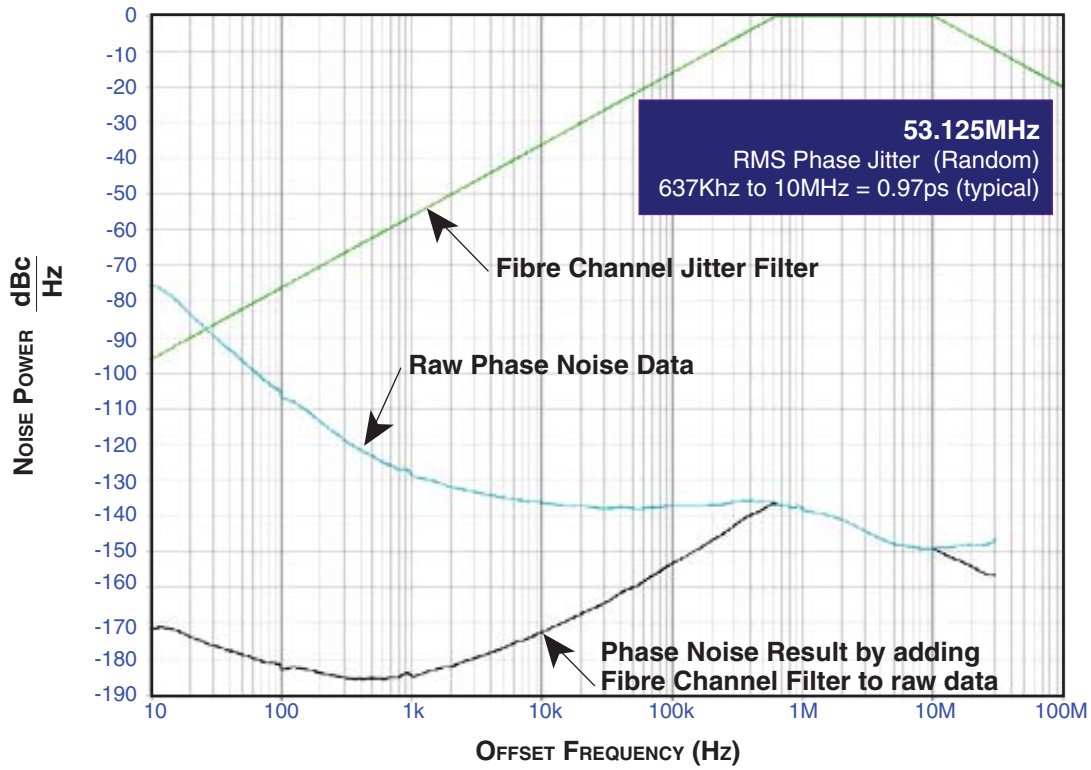

TYPICAL PHASE NOISE AT 106.25MHz

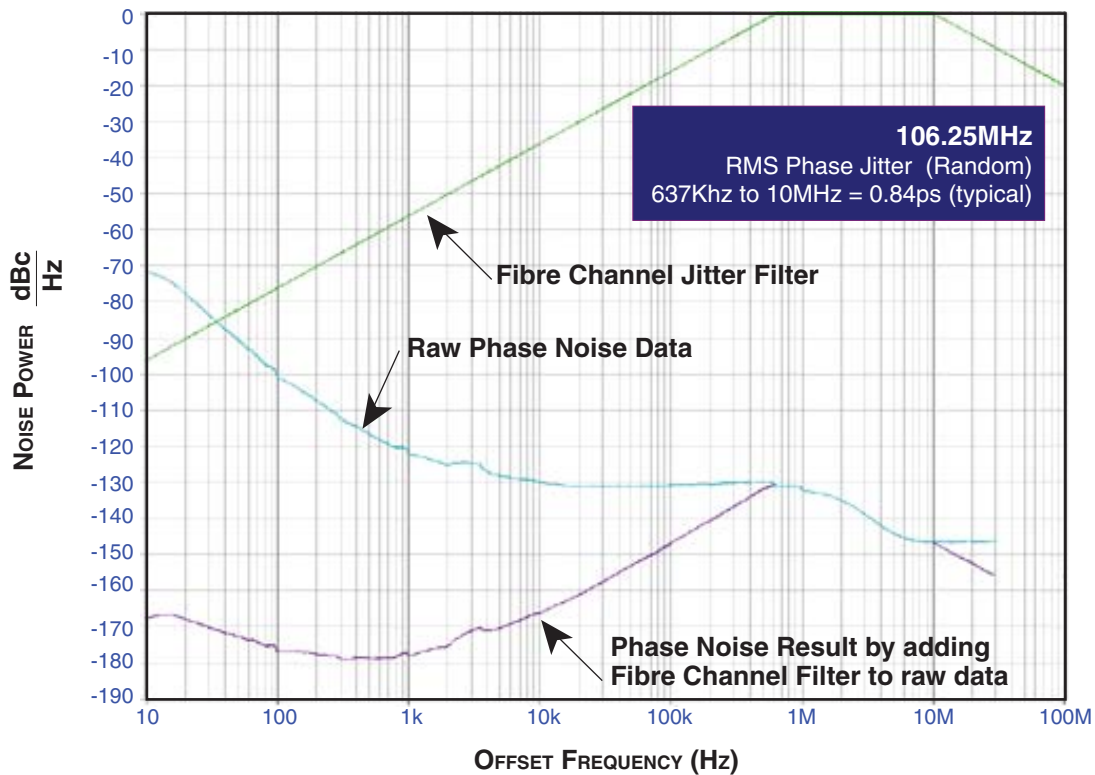

TYPICAL PHASE NOISE AT 159.375MHz

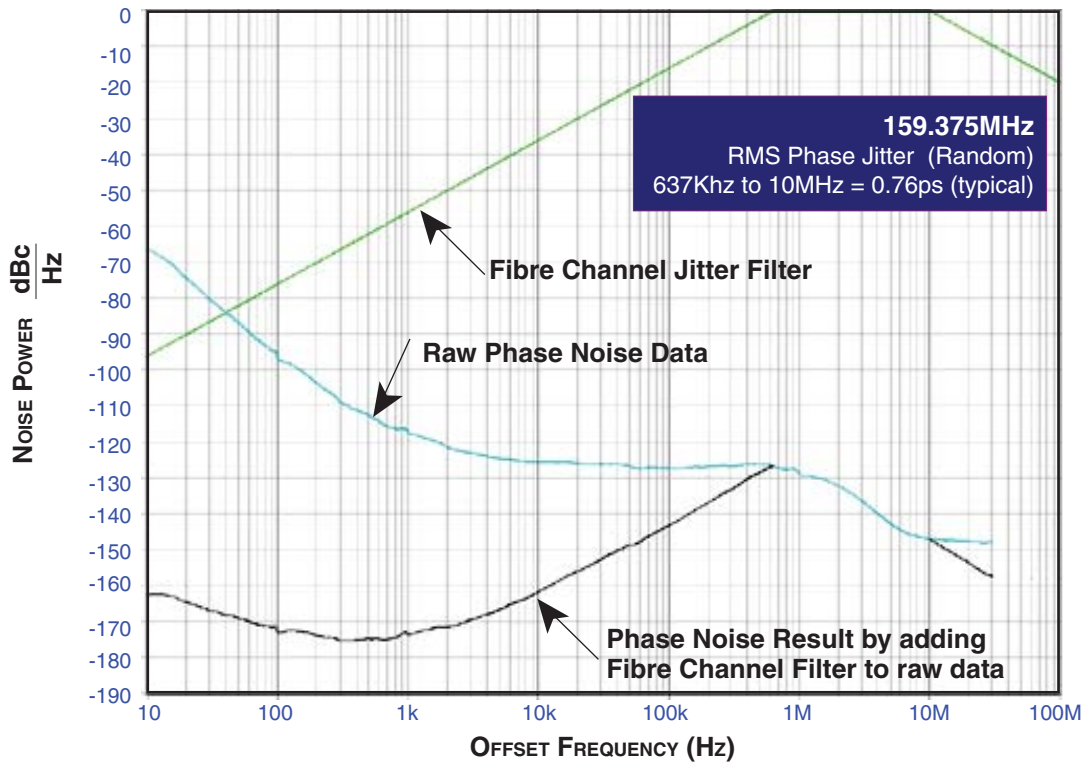

TYPICAL PHASE NOISE AT 212.5MHz

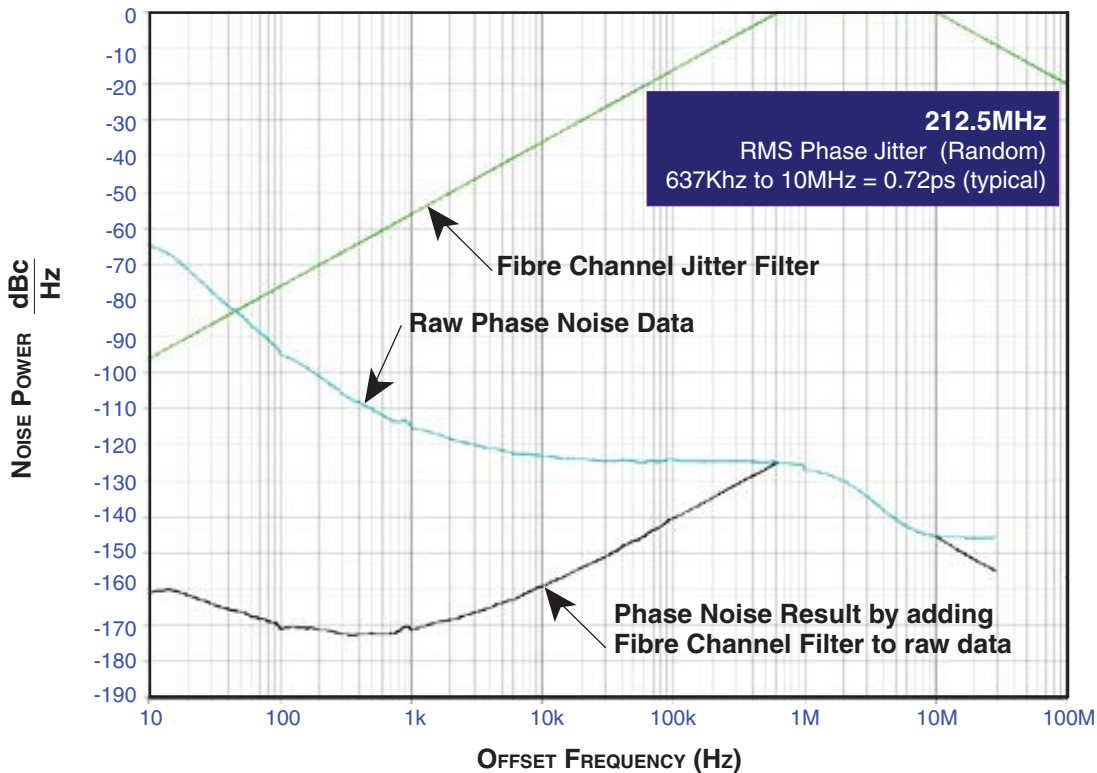

PARAMETER MEASUREMENT INFORMATION

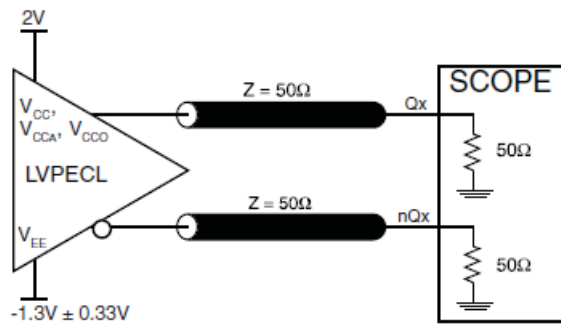
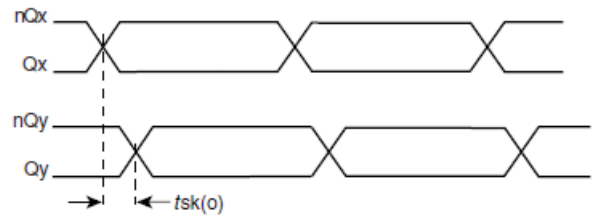
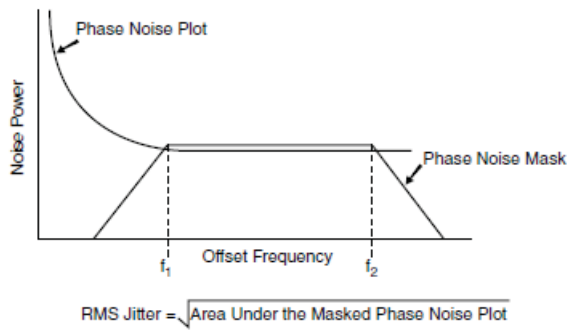
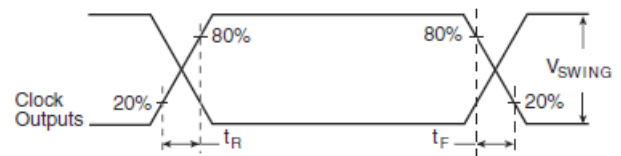
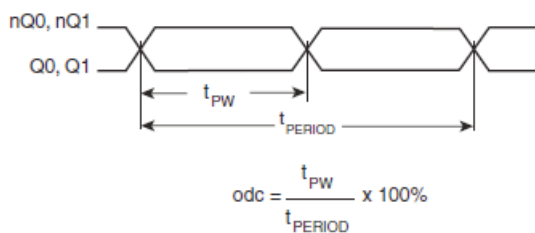
3.3V CORE/3.3V OUTPUT LOAD TEST CIRCUIT

OUTPUT SKEW

RMS PHASE JITTER

OUTPUT RISE/FALL TIME

OUTPUT DUTY CYCLE/PULSE WIDTH/PERIOD

APPLICATIONS INFORMATION

POWER SUPPLY FILTERING TECHNIQUES

As in any high speed analog circuitry, the power supply pins are vulnerable to random noise. The 843002 provides separate power supplies to isolate any high switching noise from the outputs to the internal PLL. V_{CC} , V_{CCA} , and V_{CCO} should be individually connected to the power supply plane through vias, and bypass capacitors should be used for each pin. To achieve optimum jitter performance, power supply isolation is required. *Figure 1* illustrates how a 10Ω resistor along with a 10μF and a .01μF bypass capacitor should be connected to each V_{CCA} .

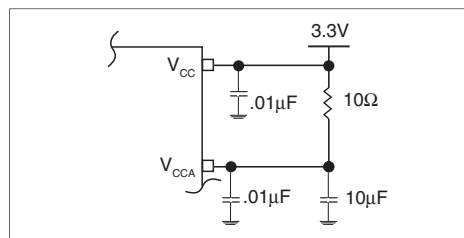

FIGURE 1. POWER SUPPLY FILTERING

TERMINATION FOR 3.3V LVPECL OUTPUT

The clock layout topology shown below is a typical termination for LVPECL outputs. The two different layouts mentioned are recommended only as guidelines.

Differential outputs are low impedance follower outputs that generate ECL/LVPECL compatible outputs. Therefore, terminating resistors (DC current path to ground) or current sources must be used for functionality. These outputs are designed to

drive 50Ω transmission lines. Matched impedance techniques should be used to maximize operating frequency and minimize signal distortion. *Figures 2A and 2B* show two different layouts which are recommended only as guidelines. Other suitable clock layouts may exist and it would be recommended that the board designers simulate to guarantee compatibility across all printed circuit and clock component process variations.

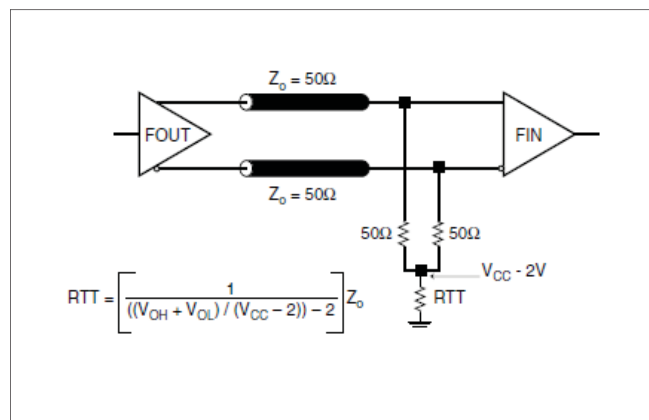

FIGURE 2A. LVPECL OUTPUT TERMINATION

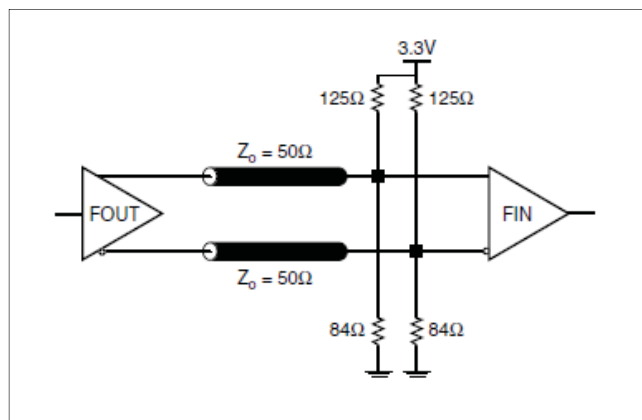

FIGURE 2B. LVPECL OUTPUT TERMINATION

CRYSTAL INPUT INTERFACE

The 843002 has been characterized with 18pF parallel resonant crystals. The capacitor values shown in *Figure 3* below were determined using a 26.5625MHz 18pF parallel resonant crystal and were chosen to minimize the ppm error.

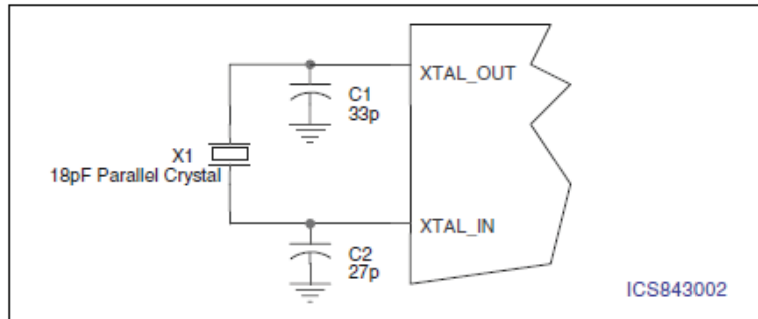

Figure 3. CRYSTAL INPUT INTERFACE

LAYOUT GUIDELINE

Figure 4A shows a schematic example of the 843002. An example of LVEPCL termination is shown in this schematic. Additional LVPECL termination approaches are shown in the LVPECL Termination Application Note. In this example, an 18

pF parallel resonant 26.5625MHz crystal is used. The C1=27pF and C2=33pF are recommended for frequency accuracy. For different board layout, the C1 and C2 may be slightly adjusted for optimizing frequency accuracy.

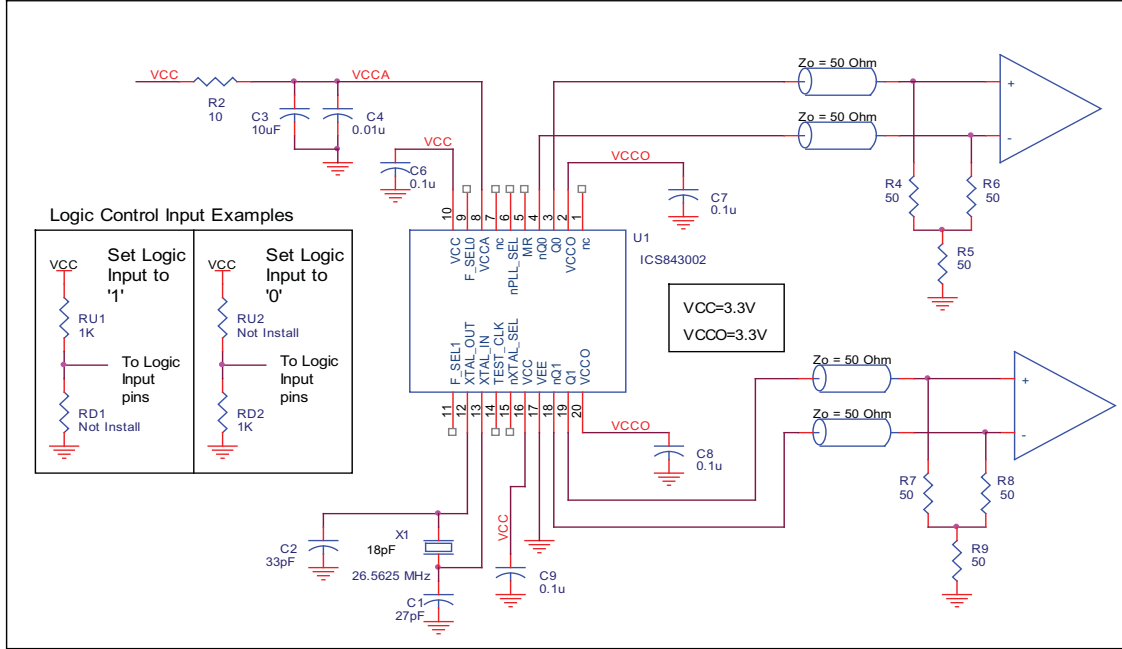

FIGURE 4A. 843002 SCHEMATIC EXAMPLE

PC BOARD LAYOUT EXAMPLE

Figure 4B shows an example of 843002 P.C. board layout. The crystal X1 footprint shown in this example allows installation of either surface mount HC49S or through-hole HC49 package. The footprints of other components in this example are listed in

the Table 6. There should be at least one decoupling capacitor per power pin. The decoupling capacitors should be located as close as possible to the power pins. The layout assumes that the board has clean analog power ground plane.

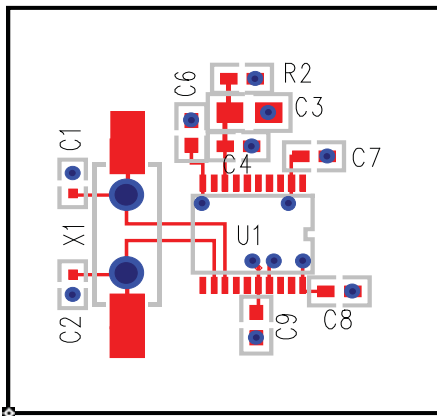

FIGURE 4B. 843002 PC BOARD LAYOUT EXAMPLE

TABLE 6. FOOTPRINT TABLE

| Reference | Size |
|--------------------|------|
| C1, C2 | 0402 |
| C3 | |
| C4, C5, C6, C7, C8 | |
| R2 | |

NOTE: Table 6, lists component sizes shown in this layout example.

POWER CONSIDERATIONS

This section provides information on power dissipation and junction temperature for the 843002. Equations and example calculations are also provided.

1. Power Dissipation.

The total power dissipation for the 843002 is the sum of the core power plus the power dissipated in the load(s). The following is the power dissipation for $V_{CC} = 3.3V + 10\% = 3.63V$, which gives worst case results.

NOTE: Please refer to Section 3 for details on calculating power dissipated in the load.

- Power (core)_{MAX} = $V_{CC_MAX} * I_{EE_MAX} = 3.63V * 135mA = 490mW$
- Power (outputs)_{MAX} = **30mW/Loaded Output pair**
If all outputs are loaded, the total power is $2 * 30mW = 60mW$

$$\text{Total Power}_{MAX} (3.63V, \text{ with all outputs switching}) = 490mW + 60mW = 550mW$$

2. Junction Temperature.

Junction temperature at the junction of the bond wire and bond pad directly affects the reliability of the device. The maximum recommended junction temperature is 125°C. Limiting the internal transistor junction temperature, T_j , to 125°C ensures that the bond wire and bond pad temperature remains below 125°C.

The equation for T_j is as follows: $T_j = \theta_{JA} * Pd_total + T_A$

T_j = Junction Temperature

θ_{JA} = Junction-to-Ambient Thermal Resistance

Pd_total = Total Device Power Dissipation (example calculation is in section 1 above)

T_A = Ambient Temperature

In order to calculate junction temperature, the appropriate junction-to-ambient thermal resistance θ_{JA} must be used. Assuming a moderate air flow of 200 linear feet per minute and a multi-layer board, the appropriate value is 66.6°C/W per Table 7 below.

Therefore, T_j for an ambient temperature of 85°C with all outputs switching is:

$$85^\circ C + 0.550W * 66.6^\circ C/W = 121.6^\circ C. \text{ This is below the limit of } 125^\circ C.$$

This calculation is only an example. T_j will obviously vary depending on the number of loaded outputs, supply voltage, air flow, and the type of board (single layer or multi-layer).

TABLE 7. THERMAL RESISTANCE θ_{JA} FOR 20-PIN TSSOP, FORCED CONVECTION

| θ_{JA} by Velocity (Linear Feet per Minute) | | | |
|--|-----------|----------|----------|
| | 0 | 200 | 500 |
| Single-Layer PCB, JEDEC Standard Test Boards | 114.5°C/W | 98.0°C/W | 88.0°C/W |
| Multi-Layer PCB, JEDEC Standard Test Boards | 73.2°C/W | 66.6°C/W | 63.5°C/W |

NOTE: Most modern PCB designs use multi-layered boards. The data in the second row pertains to most designs.

3. Calculations and Equations.

The purpose of this section is to derive the power dissipated into the load.

LVPECL output driver circuit and termination are shown in *Figure 5*.

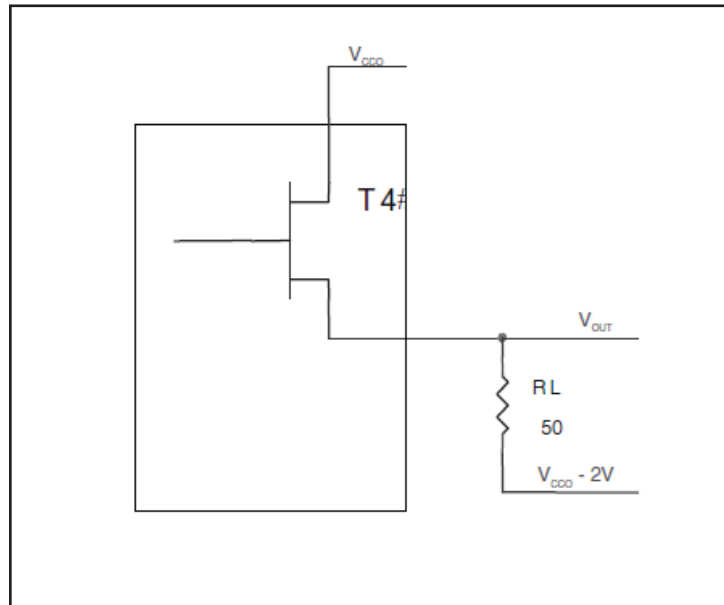

FIGURE 5. LVPECL DRIVER CIRCUIT AND TERMINATION

To calculate worst case power dissipation into the load, use the following equations which assume a 50Ω load, and a termination voltage of $V_{CCO} - 2V$.

- For logic high, $V_{OUT} = V_{OH_MAX} = V_{CCO_MAX} - 0.9V$

$$(V_{CCO_MAX} - V_{OH_MAX}) = 0.9V$$

- For logic low, $V_{OUT} = V_{OL_MAX} = V_{CCO_MAX} - 1.7V$

$$(V_{CCO_MAX} - V_{OL_MAX}) = 1.7V$$

Pd_H is power dissipation when the output drives high.

Pd_L is the power dissipation when the output drives low.

$$Pd_H = [(V_{OH_MAX} - (V_{CCO_MAX} - 2V))/R_L] * (V_{CCO_MAX} - V_{OH_MAX}) = [(2V - (V_{CCO_MAX} - V_{OH_MAX}))/R_L] * (V_{CCO_MAX} - V_{OH_MAX}) = [(2V - 0.9V)/50\Omega] * 0.9V = \mathbf{19.8mW}$$

$$Pd_L = [(V_{OL_MAX} - (V_{CCO_MAX} - 2V))/R_L] * (V_{CCO_MAX} - V_{OL_MAX}) = [(2V - (V_{CCO_MAX} - V_{OL_MAX}))/R_L] * (V_{CCO_MAX} - V_{OL_MAX}) = [(2V - 1.7V)/50\Omega] * 1.7V = \mathbf{10.2mW}$$

Total Power Dissipation per output pair = $Pd_H + Pd_L = \mathbf{30mW}$

RELIABILITY INFORMATION

TABLE 8. θ_{JA} VS. AIR FLOW TABLE FOR 20 LEAD TSSOP

| θ_{JA} by Velocity (Linear Feet per Minute) | | | |
|--|-----------|------------|------------|
| | 0 | 200 | 500 |
| Single-Layer PCB, JEDEC Standard Test Boards | 114.5°C/W | 98.0°C/W | 88.0°C/W |
| Multi-Layer PCB, JEDEC Standard Test Boards | 73.2°C/W | 66.6°C/W | 63.5°C/W |

NOTE: Most modern PCB designs use multi-layered boards. The data in the second row pertains to most designs.

TRANSISTOR COUNT

The transistor count for 843002 is: 2578

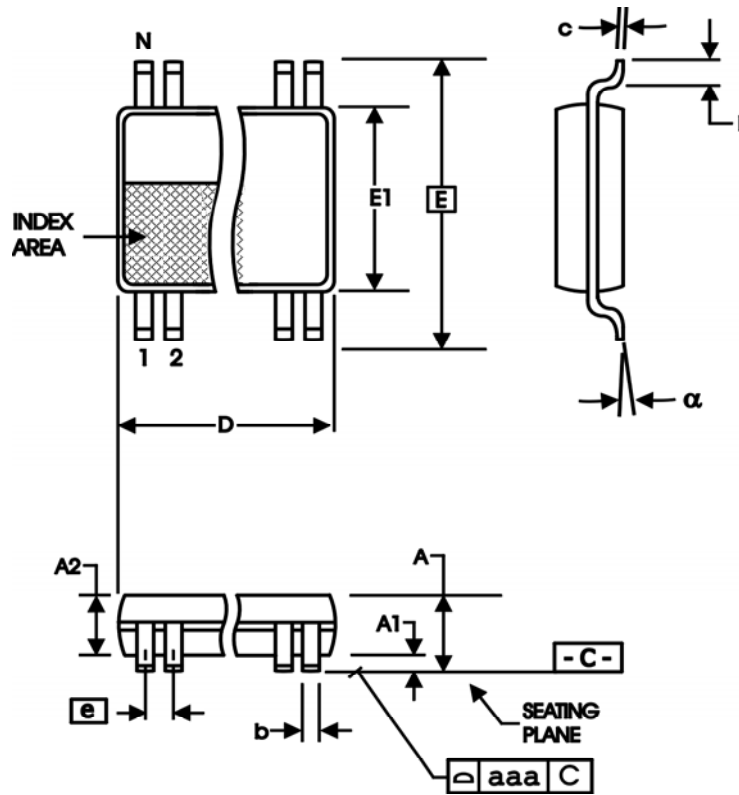
PACKAGE OUTLINE - G SUFFIX FOR 20 LEAD TSSOP

TABLE 9. PACKAGE DIMENSIONS

| SYMBOL | Millimeters | |
|----------|-------------|------|
| | MIN | MAX |
| N | 20 | |
| A | -- | 1.20 |
| A1 | 0.05 | 0.15 |
| A2 | 0.80 | 1.05 |
| b | 0.19 | 0.30 |
| c | 0.09 | 0.20 |
| D | 6.40 | 6.60 |
| E | 6.40 BASIC | |
| E1 | 4.30 | 4.50 |
| e | 0.65 BASIC | |
| L | 0.45 | 0.75 |
| α | 0° | 8° |
| aaa | -- | 0.10 |

Reference Document: JEDEC Publication 95, MO-153

TABLE 10. ORDERING INFORMATION

| Part/Order Number | Marking | Package | Shipping Packaging | Temperature |
|-------------------|--------------|---------------------------|--------------------|---------------|
| 843002AGLF | ICS843002AGL | 20 Lead "Lead-Free" TSSOP | tube | -30°C to 85°C |
| 843002AGLFT | ICS843002AGL | 20 Lead "Lead-Free" TSSOP | tape & reel | -30°C to 85°C |

| REVISION HISTORY SHEET | | | | |
|------------------------|-------|---------|---|----------|
| Rev | Table | Page | Description of Change | Date |
| A | | 1 | Added 187.5MHz to the Frequency Selection Function Table. | 8/26/04 |
| A | T10 | 15 | Ordering Information Table - added Lead Free part number. | 9/30/04 |
| A | T5 | 4 | AC Characteristics Table - corrected typo, f_{OUT} 180.67 min. to 186.67 min. | 12/27/04 |
| A | | 1 | Features section - corrected frequency bullet to read "Supports...output frequencies..." from "...input frequencies...". | 2/7/05 |
| | T10 | 15 | Ordering Information Table - updated table. | |
| B | T5 | 4 | AC Characteristics Table - deleted Propagation Delay. | 5/6/05 |
| B | T10 | 14 | Ordering Information Table - corrected lead-free marking. Updated Datasheet Header and Footer. | 4/17/13 |
| B | T10 | 1 15 | Deleted ICS from part numbers where needed. Corrected part number in the header. Ordering Information - Corrected Package information from 8 Lead TSSOP to 20 Lead TSSOP. Added T to tape and reel part number. Updated header and footer. | 1/21/16 |



Corporate Headquarters
6024 Silver Creek Valley Road
San Jose, CA 95138 USA
www.IDT.com

Sales
1-800-345-7015 or 408-284-8200
Fax: 408-284-2775
www.IDT.com/go/sales

Tech Support
www.idt.com/go/support

DISCLAIMER Integrated Device Technology, Inc. (IDT) reserves the right to modify the products and/or specifications described herein at any time, without notice, at IDT's sole discretion. Performance specifications and operating parameters of the described products are determined in an independent state and are not guaranteed to perform the same way when installed in customer products. The information contained herein is provided without representation or warranty of any kind, whether express or implied, including, but not limited to, the suitability of IDT's products for any particular purpose, an implied warranty of merchantability, or non-infringement of the intellectual property rights of others. This document is presented only as a guide and does not convey any license under intellectual property rights of IDT or any third parties.

IDT's products are not intended for use in applications involving extreme environmental conditions or in life support systems or similar devices where the failure or malfunction of an IDT product can be reasonably expected to significantly affect the health or safety of users. Anyone using an IDT product in such a manner does so at their own risk, absent an express, written agreement by IDT.

Integrated Device Technology, IDT and the IDT logo are trademarks or registered trademarks of IDT and its subsidiaries in the United States and other countries. Other trademarks used herein are the property of IDT or their respective third party owners.

For datasheet type definitions and a glossary of common terms, visit www.idt.com/go/glossary.

Copyright ©2016 Integrated Device Technology, Inc. All rights reserved.

Looking for pricing, stock, or lifecycle information?

Click below to explore more details on WIN SOURCE:

-  [View 843002AGLFT on WIN SOURCE](#)
-  [IDT, Integrated Device Technology Inc Information](#)

Optimize Your Supply Chain with WIN SOURCE Solutions

-  Global Sourcing Solution
-  Obsolete Management
-  Cost Control Management
-  Shortage Management
-  Alternative Solution
-  Excess Inventory Management