

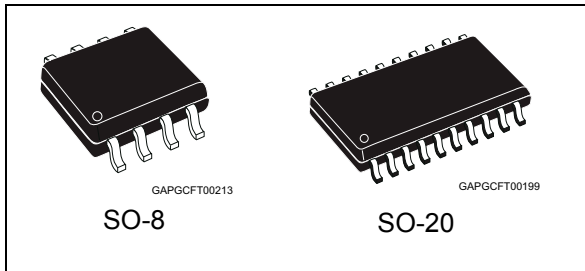


# THE DATASHEET OF L4993MDTR



## Automotive low drop voltage regulator

Datasheet - production data




### Description

The L4993 is a monolithic integrated 5 V Voltage regulator with a low drop voltage at currents up to 150 mA. The output voltage regulating element consists in a p-channel MOS and the regulation is performed regardless of input voltage transients up to 40 V. The high precision of the output voltage is obtained with a pre-trimmed reference voltage. The L4993 is protected against short circuit and an over-temperature protection switches off the device in case of extremely high power dissipation. The L4993 watchdog is active when the Enable is high. State of the art features like reset and watchdog make this device particularly suitable to supply microprocessor systems in automotive applications.

### Features

Max DC supply voltage	$V_S$	40 V
Max output voltage tolerance	$\Delta V_0$	+/-2%
Max dropout voltage	$V_{dp}$	400 mV
Output current	$I_0$	150 mA
Quiescent current	$I_{qn}$	79 $\mu$ A <sup>(1)</sup>

1. Typical value with watchdog disabled.

- AEC-Q100 qualified 
- Operating DC supply voltage range 5.6 V to 31 V
- Reset circuit sensing the output voltage down to 1 V
- Programmable reset pulse delay with external capacitor
- Watchdog
- Programmable watchdog timer with external
- Enable input for enabling/disabling the watchdog functionality
- Thermal shutdown and short circuit protection
- Wide temperature range ( $T_j = -40^\circ\text{C}$  to  $150^\circ\text{C}$ )

**Table 1. Device summary**

Package	Order codes	
	Tube	Tape & reel
SO-8	—	L4993DTR
SO-20 (16+2+2)	L4993MD	L4993MDTR

# Contents

<b>1</b>	<b>Block diagram and pins description</b>	<b>5</b>
<b>2</b>	<b>Electrical specifications</b>	<b>7</b>
2.1	Absolute maximum ratings	7
2.2	Thermal data	7
2.3	Electrical characteristics	8
2.4	Electrical characteristics curves	11
2.5	Test circuit and waveforms plot	14
2.5.1	Load regulation	14
<b>3</b>	<b>Application information</b>	<b>16</b>
3.1	Voltage regulator	16
3.2	Reset	17
3.3	Watchdog	18
<b>4</b>	<b>Package and PCB thermal data</b>	<b>19</b>
4.1	SO-8 thermal data	19
4.2	SO-20 thermal data	22
<b>5</b>	<b>Package and packing information</b>	<b>25</b>
5.1	ECOPACK®	25
5.2	SO-8 package information	25
5.3	SO-20 package information	27
5.4	SO-8 packing information	28
5.5	SO-20 packing information	29
<b>6</b>	<b>Revision history</b>	<b>30</b>

## List of tables

Table 1.	Device summary . . . . .	1
Table 2.	Pins description . . . . .	6
Table 3.	Absolute maximum ratings . . . . .	7
Table 4.	Thermal data . . . . .	7
Table 5.	General . . . . .	8
Table 6.	Reset . . . . .	9
Table 7.	Watchdog . . . . .	9
Table 8.	Watchdog Enable . . . . .	10
Table 9.	SO-8 thermal parameter . . . . .	21
Table 10.	SO-20 thermal parameter . . . . .	24
Table 11.	SO-8 mechanical data . . . . .	25
Table 12.	SO-20 mechanical data . . . . .	27
Table 13.	Document revision history . . . . .	30

## List of figures

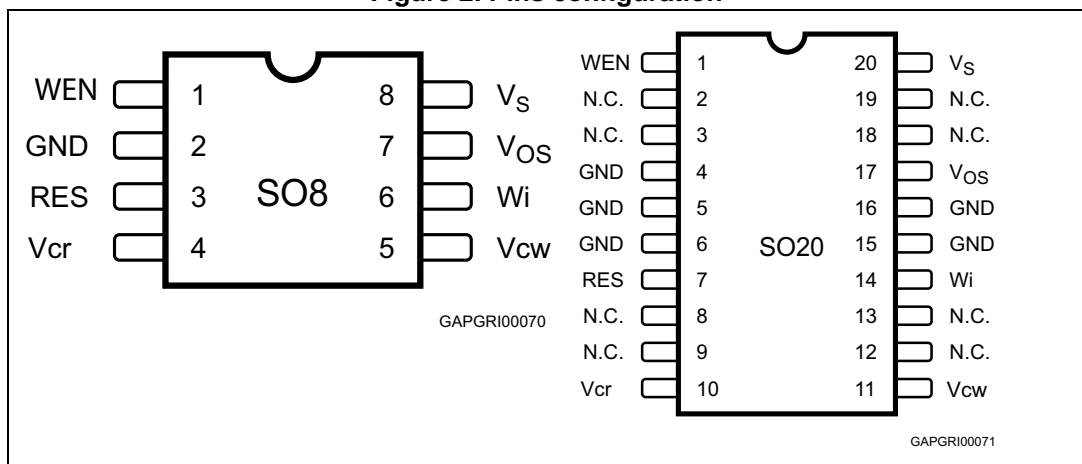
Figure 1.	Block diagram . . . . .	5
Figure 2.	Pins configuration . . . . .	6
Figure 3.	Output voltage vs. $T_j$ . . . . .	11
Figure 4.	Output voltage vs. $V_s$ . . . . .	11
Figure 5.	Drop Voltage vs. Output Current . . . . .	11
Figure 6.	Current consumption vs. Output Current . . . . .	11
Figure 7.	Current consumption vs. Input Voltage . . . . .	11
Figure 8.	Current limitation vs. $T_j$ . . . . .	11
Figure 9.	Current limitation vs. Input Voltage . . . . .	12
Figure 10.	Short Circuit Current vs. $T_j$ . . . . .	12
Figure 11.	Short Circuit Current vs. Input Voltage . . . . .	12
Figure 12.	$V_{WEn\_high}$ vs. $T_j$ . . . . .	12
Figure 13.	$V_{WEn\_LOW}$ vs. $T_j$ . . . . .	12
Figure 14.	$V_{rhth}$ vs. $T_j$ . . . . .	12
Figure 15.	$V_{rlth}$ vs. $T_j$ . . . . .	13
Figure 16.	$V_{whth}$ vs. $T_j$ . . . . .	13
Figure 17.	$V_{wlth}$ vs. $T_j$ . . . . .	13
Figure 18.	$I_{cr}$ & $I_{cwc}$ vs. $T_j$ . . . . .	13
Figure 19.	$I_{dr}$ & $I_{cwd}$ vs. $T_j$ . . . . .	13
Figure 20.	$T_{wop}$ vs. $T_j$ . . . . .	13
Figure 21.	PSRR . . . . .	14
Figure 22.	Load regulation test circuit . . . . .	14
Figure 23.	Maximum load variation response . . . . .	15
Figure 24.	L4993 application schematic . . . . .	16
Figure 25.	Behavior of output current versus regulated voltage $V_o$ . . . . .	17
Figure 26.	Reset timing diagram . . . . .	18
Figure 27.	Watchdog timing diagram . . . . .	18
Figure 28.	SO-8 PC board . . . . .	19
Figure 29.	$R_{thj-amb}$ Vs. PCB copper area in open box free air condition . . . . .	19
Figure 30.	SO-8 thermal impedance junction ambient single pulse . . . . .	20
Figure 31.	Thermal fitting model of $V_{reg}$ in SO-8 . . . . .	20
Figure 32.	SO-20 PC board . . . . .	22
Figure 33.	$R_{thj-amb}$ Vs. PCB copper area in open box free air condition . . . . .	22
Figure 34.	SO-20 thermal impedance junction ambient single pulse . . . . .	23
Figure 35.	Thermal fitting model of $V_{reg}$ in SO-20 . . . . .	23
Figure 36.	SO-8 package dimensions . . . . .	25
Figure 37.	SO-20 package dimensions . . . . .	27
Figure 38.	SO-8 tape and reel shipment (suffix "TR") . . . . .	28
Figure 39.	SO-20 tube shipment (no suffix) . . . . .	29
Figure 40.	SO-20 tape and reel shipment (suffix "TR") . . . . .	29



Table 2. Pins description

Pin name	SO-8 (D)	SO-20 (MD)	Function
WEn	1	1	Watchdog Enable input If high watchdog functionality is active
Gnd	2	4	Ground reference
Gnd		5, 6, 15, 16	Ground Connected these pins to a heat spreader ground
Res	3	7	Reset output. It is pulled down when output voltage goes below Vo_th or frequency at Wi is too low. Leave floating if not used.
Vcr	4	10	Reset timing adjust. A capacitor between Vcr pin and gnd, sets the reset delay time (trd)
Vcw	5	11	Watchdog timer adjust A capacitor between Vcw pin and gnd, sets the time response of the watchdog monitor.
Wi	6	14	Watchdog input. If the frequency at this input pin is too low, the Reset output is activated. Connect to ground if not used
Vo <sub>s</sub>	7	17	Voltage regulator output Block to ground with a capacitor >100 nF (needed for regulator stability)
Vs	8	20	Supply voltage Block to ground directly at IC pin with a capacitor
N.C.		2, 3, 8, 9, 12, 13, 18, 19	Not connected

Figure 2. Pins configuration



## 2 Electrical specifications

### 2.1 Absolute maximum ratings

Stressing the device above the rating listed in [Table 3: Absolute maximum ratings](#) may cause permanent damage to the device. These are stress ratings only and operation of the device at these or any other conditions above those indicated in the Operating sections of this specification is not implied. Exposure to the conditions in the table below for extended periods may affect device reliability.

**Table 3. Absolute maximum ratings**

Symbol	Parameter	Value	Unit
$V_{VSDC}$	DC supply voltage	-0.3 to 40	V
$I_{VSDC}$	Input current	Internally limited	
$V_{VO}$	DC output voltage	-0.3 to 6 <sup>(1)</sup>	V
$I_{VO}$	DC output current	Internally limited	
$V_{WI}$	Watchdog input voltage	-0.3 to $V_{VO} + 0.3$	V
$V_{OD}$	Open drain output voltage	-0.3 to $V_{VO} + 0.3$	V
$I_{OD}$	Open drain output current	Internally limited	
$V_{CR}$	Reset delay voltage	-0.3 to $V_{VO} + 0.3$	V
$V_{CW}$	Watchdog delay voltage	-0.3 to $V_{VO} + 0.3$	V
$V_{WEN}$	Watchdog Enable input voltage	-0.3 to $V_{VO} + 0.3$	V
$T_J$	Junction temperature	-40 to 150	°C
$V_{ESD}$	ESD voltage level (HBM-MIL STD 883C)	±2	kV
$V_{ESD}$	ESD voltage level (CDM AEC-Q100-011)	750	V

1. Using the typical application schematic with  $C_{out} = 10 \mu F$  and  $I_{out} = 0 A$ , when the regulator is switched-on, an overshoot exceeding 6 V could occur. This behavior does not impact the reliability of the regulator.

### 2.2 Thermal data

For details, please refer to [Section 4.1: SO-8 thermal data](#) and [Section 4.2: SO-20 thermal data](#).

**Table 4. Thermal data<sup>(1)</sup>**

Symbol	Parameter	Value	Unit
$R_{th-jamb}$	Thermal resistance Junction to Ambient:		
	SO-8	130	°C/W
	SO-20	51	°C/W

1. The values quoted are for PCB FR4 area= 58mm x 58mm, PCB thickness = 2 mm, Cu thickness = 35  $\mu m$ , Copper areas: SO-8= 2 cm<sup>2</sup>, SO-20= 6 cm<sup>2</sup>.

## 2.3 Electrical characteristics

Values specified in this section are for  $V_s = 5.6 \text{ V to } 31 \text{ V}$ ,  $T_j = -40^\circ\text{C to } +150^\circ\text{C}$  unless otherwise stated.

Table 5. General

Pin	Symbol	Parameter	Test condition	Min.	Typ.	Max.	Unit
Vo	$V_{o\_ref}$	Output voltage	$V_s = 6 \text{ to } 31 \text{ V}$ $I_o = 1 \text{ to } 150 \text{ mA}$	4.9	5.0	5.1	V
Vo	$I_{short}$	Short circuit current	$V_s = 13.5 \text{ V}^{(1)}$	150	280	400	mA
Vo	$I_{lim}^{(2)}$	Output current limitation	$V_s = 13.5 \text{ V}^{(1)}$	150	320	500	mA
Vs, Vo	$V_{line}$	Line regulation voltage	$V_s = 6 \text{ to } 31 \text{ V}$ $I_o = 1 \text{ to } 150 \text{ mA}$			25	mV
Vo	$V_{load}$	Load regulation voltage	$I_o = 1 \text{ to } 150 \text{ mA}$			25	mV
Vs, Vo	$V_{dp}^{(3)}$	Drop voltage	$I_o = 150 \text{ mA}$		200	400	mV
Vs, Vo	SVR	Ripple rejection	$f_r = 100 \text{ Hz}^{(4)}$	55			dB
Vs, Vo	$I_{qn\_150}$	Quiescent current	$V_s = 13.5 \text{ V}$ , $I_o = 150 \text{ mA}$ , $WEn = \text{high}$		1.25	2	mA
Vs, Vo	$I_{qn\_50}$	Quiescent current	$V_s = 13.5 \text{ V}$ , $I_o = 50 \text{ mA}$ , $WEn = \text{high}$		470	1000	$\mu\text{A}$
Vs, Vo	$I_{qn\_1}$	Quiescent current	$V_s = 13.5 \text{ V}$ , $I_o < 1 \text{ mA}$ , $WEn = \text{high}$		100	180	$\mu\text{A}$
Vs, Vo	$I_{qs}$	Quiescent current with watchdog regulator disabled	$V_s = 13.5 \text{ V}$ , $I_o < 1 \text{ mA}$ , $WEn = \text{low}$		79	125	$\mu\text{A}$
	$T_w$	Thermal protection temperature		150		190	$^\circ\text{C}$
	$T_w\_hy$	Thermal protection temperature hysteresis			10		$^\circ\text{C}$

1. See [Figure 25](#).
2. Measured output current when the output voltage has dropped 100 mV from its nominal value obtained at  $V_s = 13.5 \text{ V}$  and  $I_o = 75 \text{ mA}$ .
3.  $V_s - V_o$  measured when the output voltage has dropped 100mV from its nominal value obtained at  $V_s = 13.5 \text{ V}$  and  $I_o = 75 \text{ mA}$ .
4. Guaranteed by design.

Table 6. Reset

Pin	Symbol	Parameter	Test condition	Min.	Typ.	Max.	Unit
Res	Vres_l	Reset output low voltage	$R_{ext} = 5 \text{ k}\Omega$ to $V_o$ , $V_o > 1 \text{ V}$			0.4	V
Res	$I_{Res\_h}$	Reset output high leakage current	$V_{Res} = 5 \text{ V}$			1	$\mu\text{A}$
Res	R_p_u	Pull up internal resistance	With respect to $V_o$	12	25	50	$\text{k}\Omega$
Res	$V_o\_th$	$V_o$ out of regulation threshold	$V_s = 6$ to $31 \text{ V}$ , $I_o = 1$ to $150 \text{ mA}$	6%	8%	10%	Below $V_{o\_ref}$
Vcr	Vr1th	Reset delay circuit low threshold	$V_s = 13.5 \text{ V}$	10%	13%	16%	$V_{o\_ref}$
Vcr	Vr1th	Reset delay circuit high threshold	$V_s = 13.5 \text{ V}$	44%	47%	50%	$V_{o\_ref}$
Vcr	Icr	Charge current	$V_s = 13.5 \text{ V}$	8	17.6	30	$\mu\text{A}$
Vcr	Idr	Discharge current	$V_s = 13.5 \text{ V}$	8	17.6	30	$\mu\text{A}$
Res	Trr_2	Reset reaction time <sup>(1)</sup>	$V_o = V_{o\_th} - 100 \text{ mV}$	100	275	1000	$\mu\text{s}$
Res	Trd	Reset delay time	$V_s = 13.5 \text{ V}$ , $C_{tr} = 1 \text{ nF}$	65		150	ms

1. When  $V_o$  becomes lower than 4 V, the reset reaction time decreases down to 2  $\mu\text{s}$  assuring a faster reset condition in this particular case.

Table 7. Watchdog

Pin	Symbol	Parameter	Test condition	Min.	Typ.	Max.	Unit
Wi	Vih	Input high voltage	$V_s = 13.5 \text{ V}$	3.5			V
Wi	Vil	Input low voltage	$V_s = 13.5 \text{ V}$			1.5	V
Wi	Vih_hyst	Input hysteresis	$V_s = 13.5 \text{ V}$		500		mV
Wi	li	Pull down current	$V_s = 13.5 \text{ V}$		10	20	$\mu\text{A}$
Vcw	Vwhth	High threshold	$V_s = 13.5 \text{ V}$	44%	47%	50%	$V_{o\_ref}$
Vcw	Vwlth	Low threshold	$V_s = 13.5 \text{ V}$	10%	13%	16%	$V_{o\_ref}$
Vcw	Icwc	Charge current	$V_s = 13.5 \text{ V}$ , $V_{cw} = 0.1 \text{ V}$	4	8	14	$\mu\text{A}$

Table 7. Watchdog (continued)

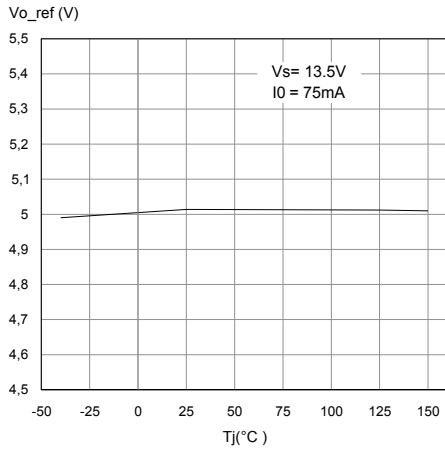
Pin	Symbol	Parameter	Test condition	Min.	Typ.	Max.	Unit
Vcw	Icwd	Discharge current	Vs = 13.5 V, Vcw = 2.5 V	1.0	2.13	4.5	μA
Vcw	Twop	Watchdog period	Vs = 13.5 V, Ctw = 47 nF	25	50	90	ms
Res	twol	Watchdog output low time	Vs = 13.5 V, Ctw = 47 nF	6	10.5	22	ms

Table 8. Watchdog Enable

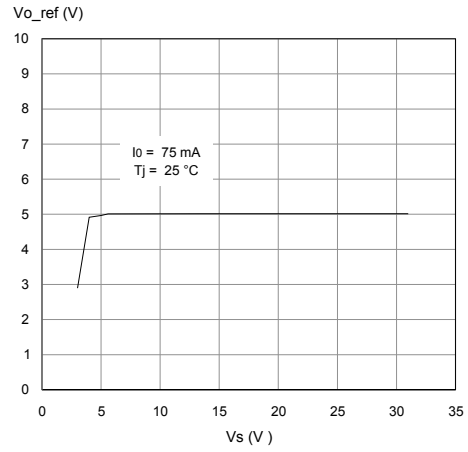
Pin	Symbol	Parameter	Test condition	Min.	Typ.	Max.	Unit
WEn	W <sub>En_low</sub>	Enable input low voltage				1	V
WEn	W <sub>En_high</sub>	Enable input high voltage		3			V
WEn	W <sub>En_hyst</sub>	Enable input hysteresis		500	800	1100	mV
WEn	I <sub>leak</sub>	Pull down current	WEn = 5 V	2	8	20	μA

## 2.4 Electrical characteristics curves

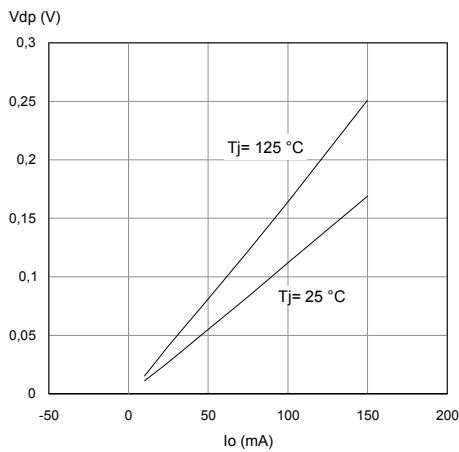
**Figure 3. Output voltage vs. Tj**



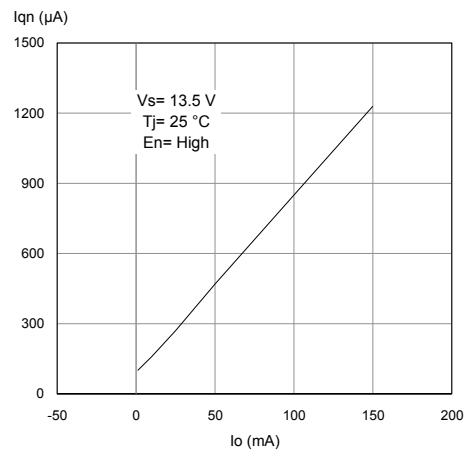
**Figure 4. Output voltage vs. Vs**



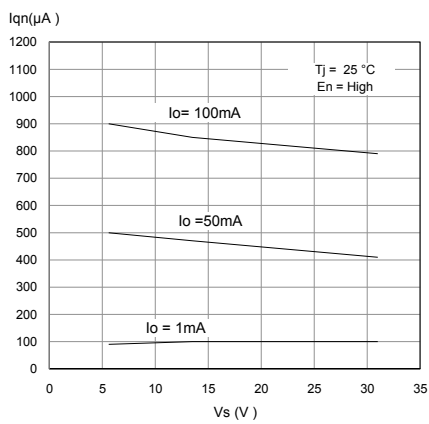
**Figure 5. Drop Voltage vs. Output Current**



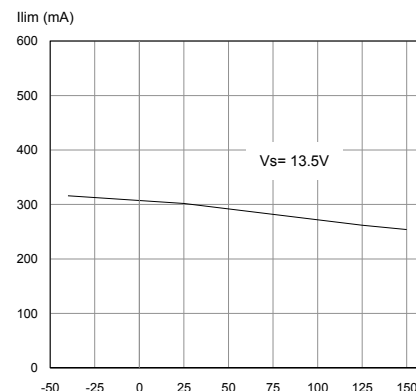
**Figure 6. Current consumption vs. Output Current**



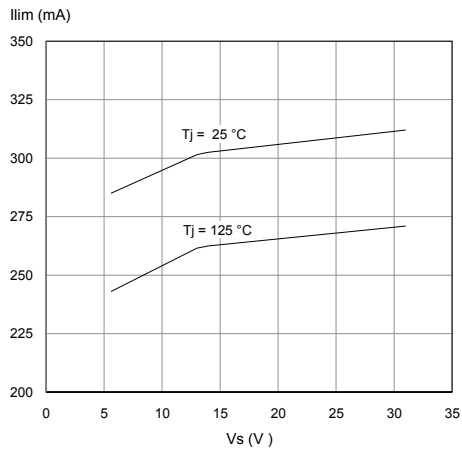
**Figure 7. Current consumption vs. Input Voltage**



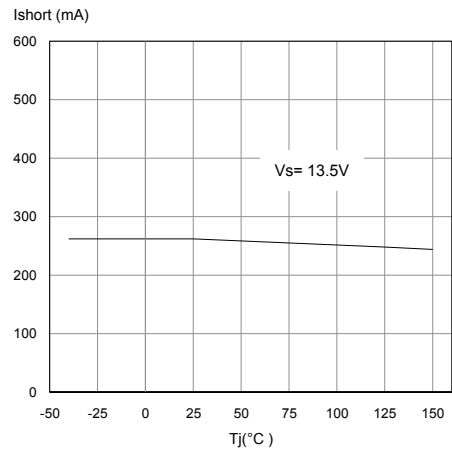
**Figure 8. Current limitation vs. Tj**



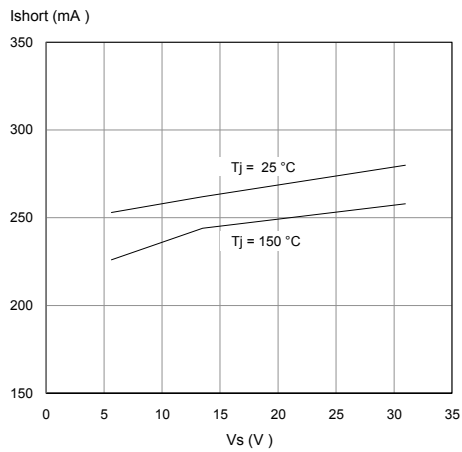
**Figure 9. Current limitation vs. Input Voltage**



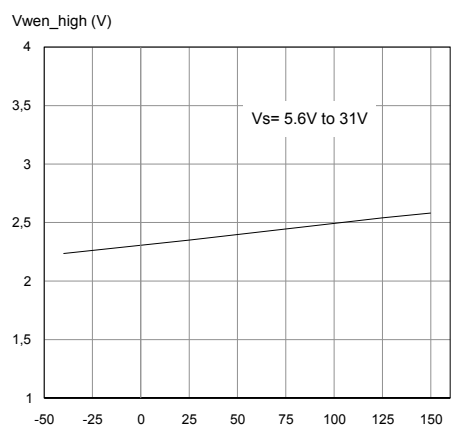
**Figure 10. Short Circuit Current vs. Tj**



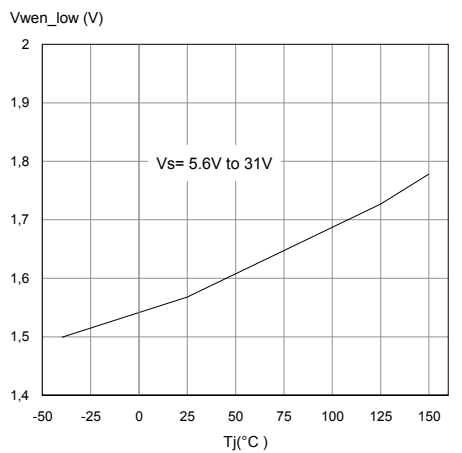
**Figure 11. Short Circuit Current vs. Input Voltage**



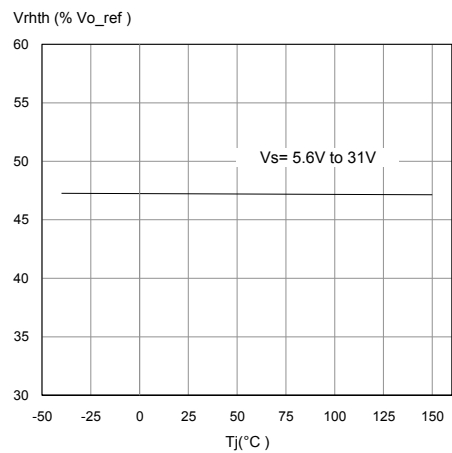
**Figure 12. VwEn\_high vs. Tj**



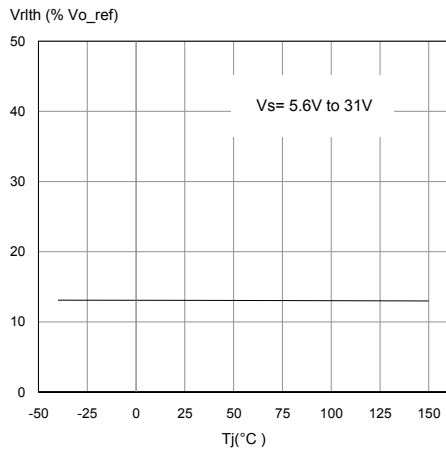
**Figure 13. VwEn\_LOW vs. Tj**



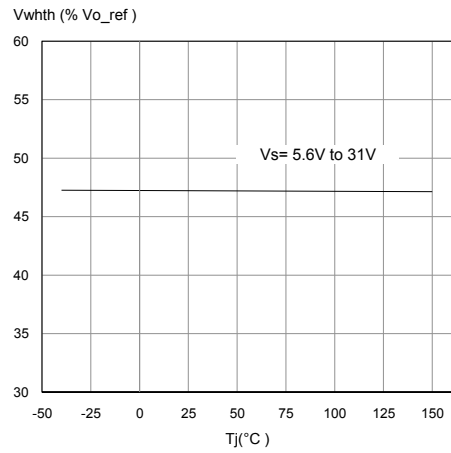
**Figure 14. Vrhth vs. Tj**



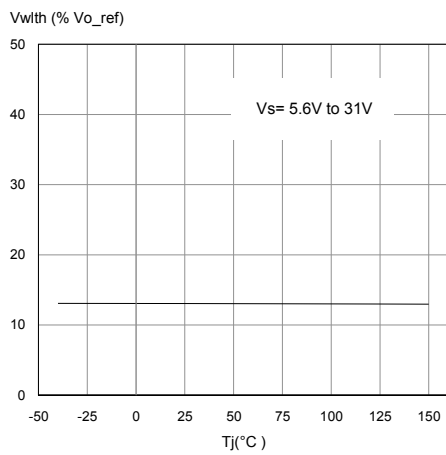
**Figure 15. Vr1th vs. Tj**



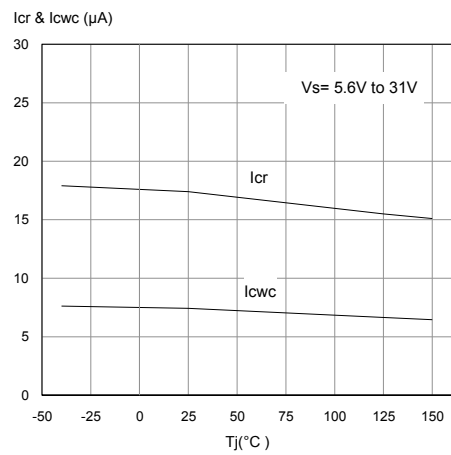
**Figure 16. Vwhth vs. Tj**



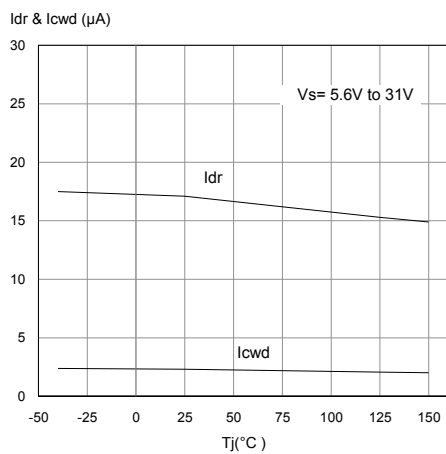
**Figure 17. Vwlth vs. Tj**



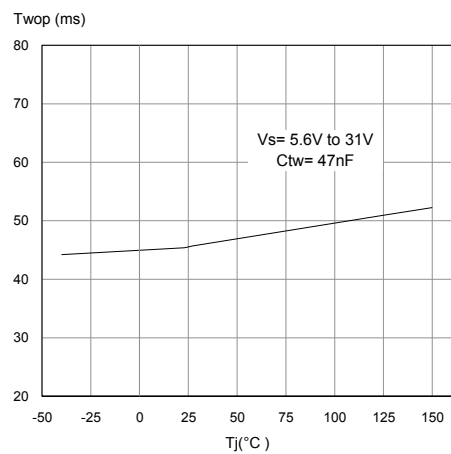
**Figure 18. Icr & Icw vs. Tj**

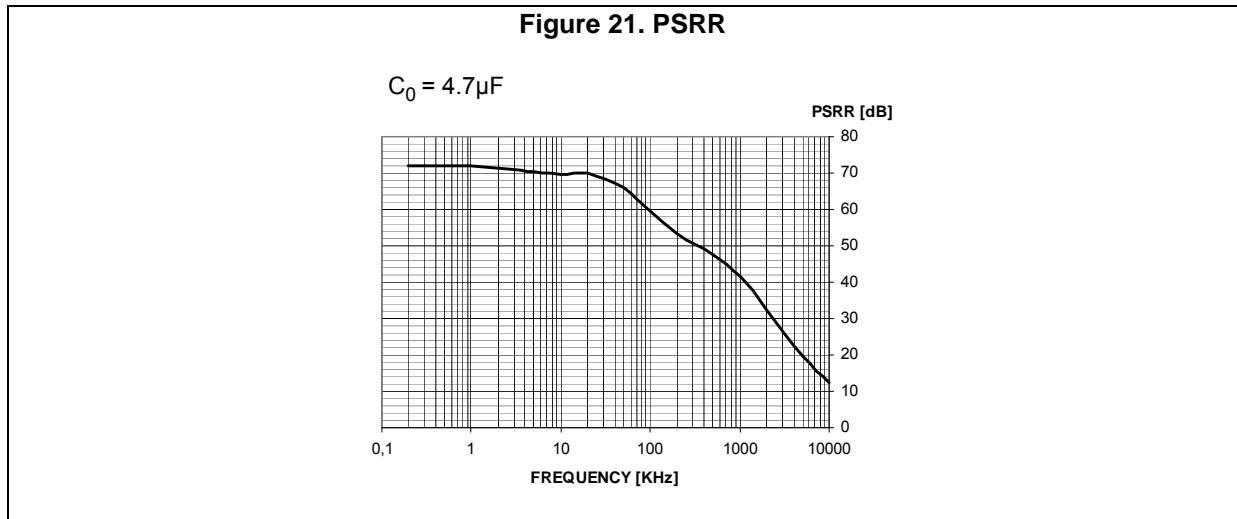


**Figure 19. Idr & Icd vs. Tj**



**Figure 20. Twop vs. Tj**





## 2.5 Test circuit and waveforms plot

### 2.5.1 Load regulation

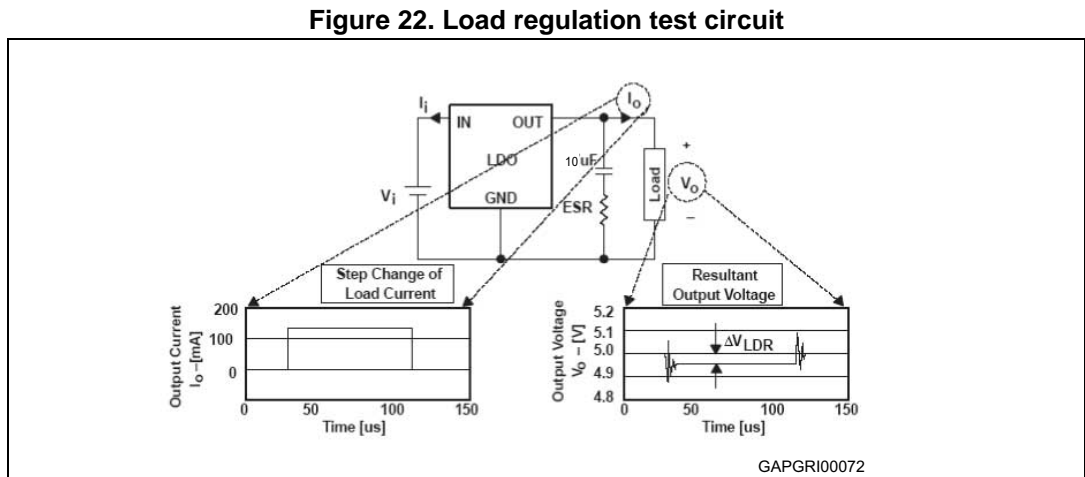


Figure 23. Maximum load variation response

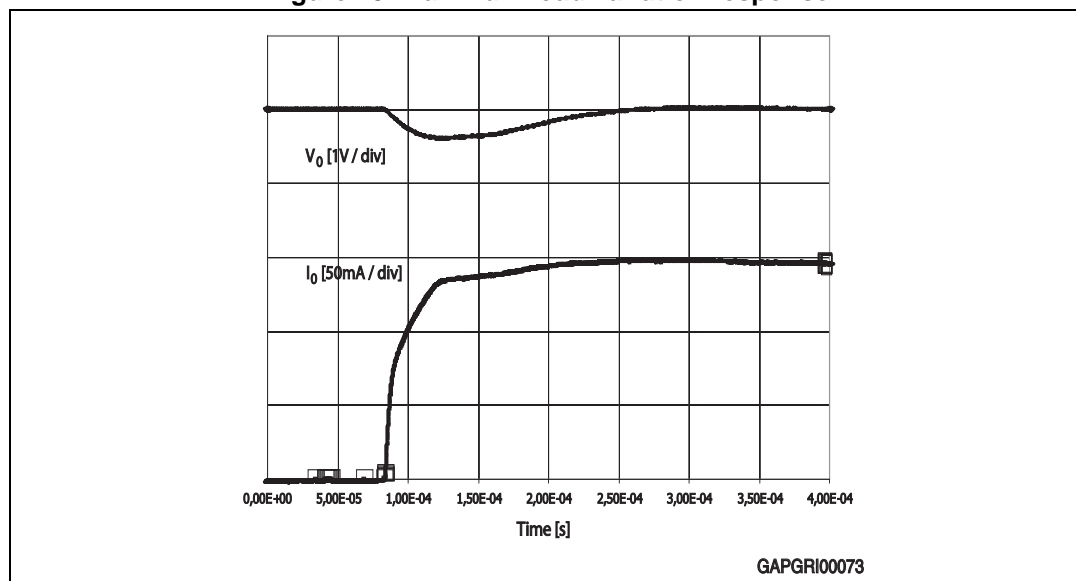
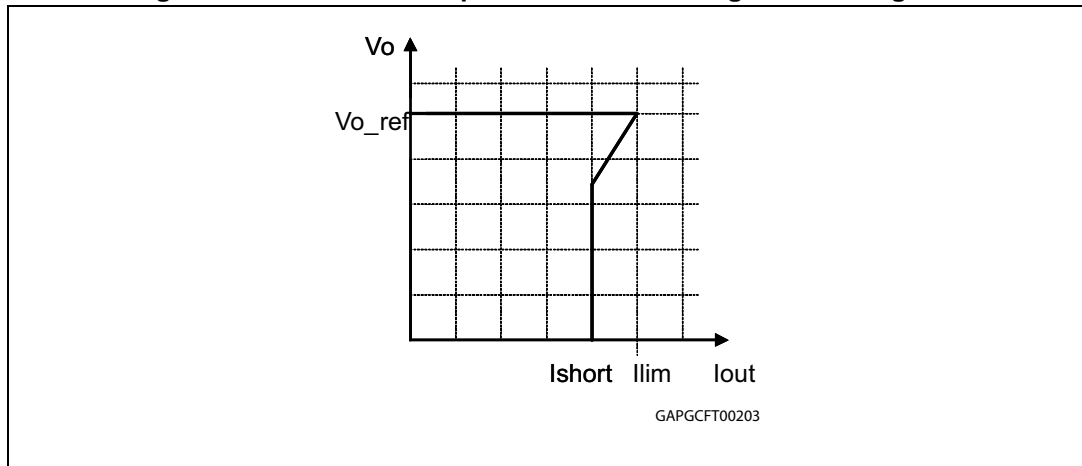




Figure 25. Behavior of output current versus regulated voltage Vo



### 3.2 Reset

The reset circuit supervises the output voltage  $V_o$ . The  $V_{o\_th}$  reset threshold is defined with the internal reference voltage and a resistor output divider. If the output voltage becomes lower than  $V_{o\_th}$  then Res goes low with a reaction time  $t_{rr}$ . The reset low signal is guaranteed for an output voltage  $V_o$  greater than 1 V.

When the output voltage becomes higher than  $V_{o\_th}$  then Res goes high with a delay  $t_{rd}$ . This delay is obtained by an internal oscillator.

The oscillator period is given by:

$$T_{osc} = [(V_{rhth} - V_{rlth}) \times C_{tr}] / I_{cr} + [(V_{rhth} - V_{rlth}) \times C_{tr}] / I_{dr}$$

where:

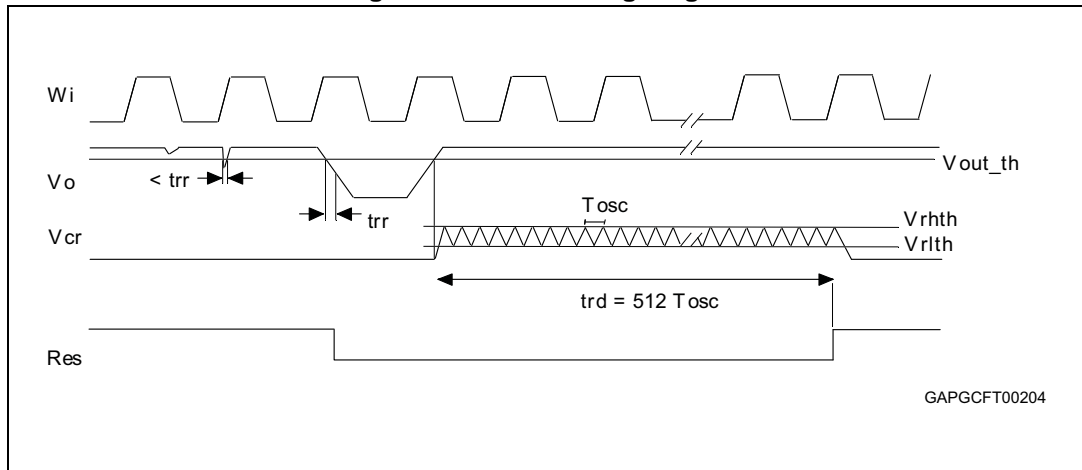
- $I_{cr}$ : is an internally generated charge current
- $I_{dr}$ : is an internally generated discharge current
- $V_{rhth}$ ,  $V_{rlth}$ : are two voltages defined with the output voltage and a resistor output divider
- $C_{tr}$ : is an external capacitance.

$t_{rd}$  is given by:

$$t_{rd} = 512 \times T_{osc}$$

Reset is active when  $En$  is high.

Figure 26. Reset timing diagram



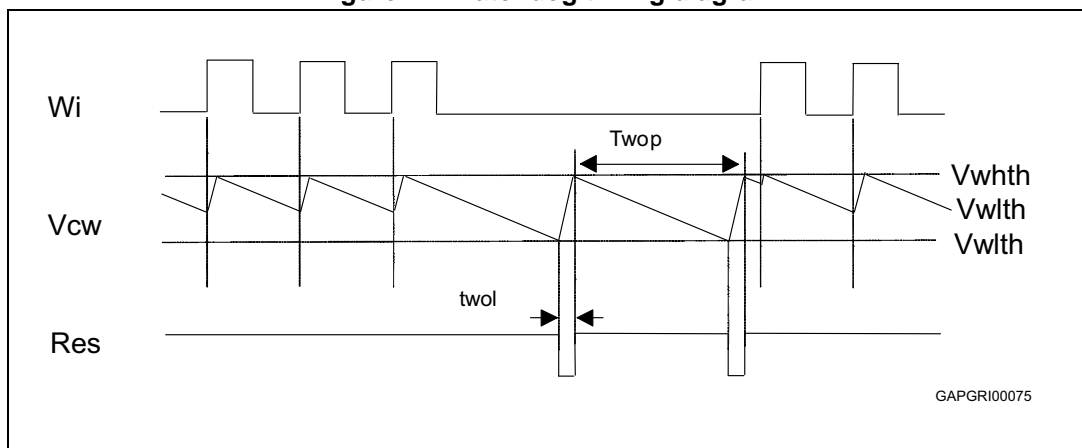
### 3.3 Watchdog

A connected microcontroller is monitored by the watchdog input  $W_i$ . If pulses are missing, the Reset output pin is set to low. The pulse sequence time can be set within a wide range with the external capacitor,  $C_{tw}$ . The watchdog circuit discharges the capacitor  $C_{tw}$ , with the constant current  $I_{cwd}$ . If the lower threshold  $V_{wlth}$  is reached, a watchdog reset is generated. To prevent this the microcontroller must generate a positive edge during the discharge of the capacitor before the voltage has reached the threshold  $V_{wlth}$ . In order to calculate the minimum time  $t$ , during which the micro-controller must output the positive edge, the following equation can be used:

$$(V_{whth} - V_{wlth}) \times C_{tw} = I_{cwd} \times t$$

Every  $W_i$  positive edge switches the current source from discharging to charging. The same happens when the lower threshold is reached. When the voltage reaches the upper threshold,  $V_{whth}$ , the current switches from charging to discharging. The result is a saw-tooth voltage at the watchdog timer capacitor  $C_{tw}$ .

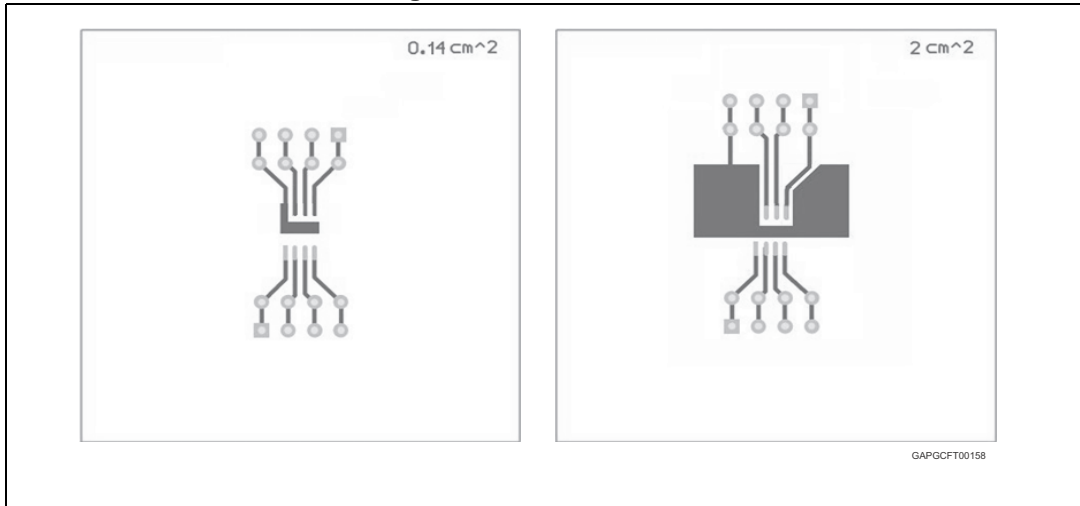
Figure 27. Watchdog timing diagram



## 4 Package and PCB thermal data

### 4.1 SO-8 thermal data

Figure 28. SO-8 PC board



Note: Layout condition of  $R_{th}$  and  $Z_{th}$  measurements (PCB FR4 area= 58mm x 58mm, PCB thickness = 2 mm, Cu thickness = 35  $\mu$ m, Copper areas: from minimum pad lay-out to 2 cm<sup>2</sup>).

Figure 29.  $R_{thj-amb}$  Vs. PCB copper area in open box free air condition

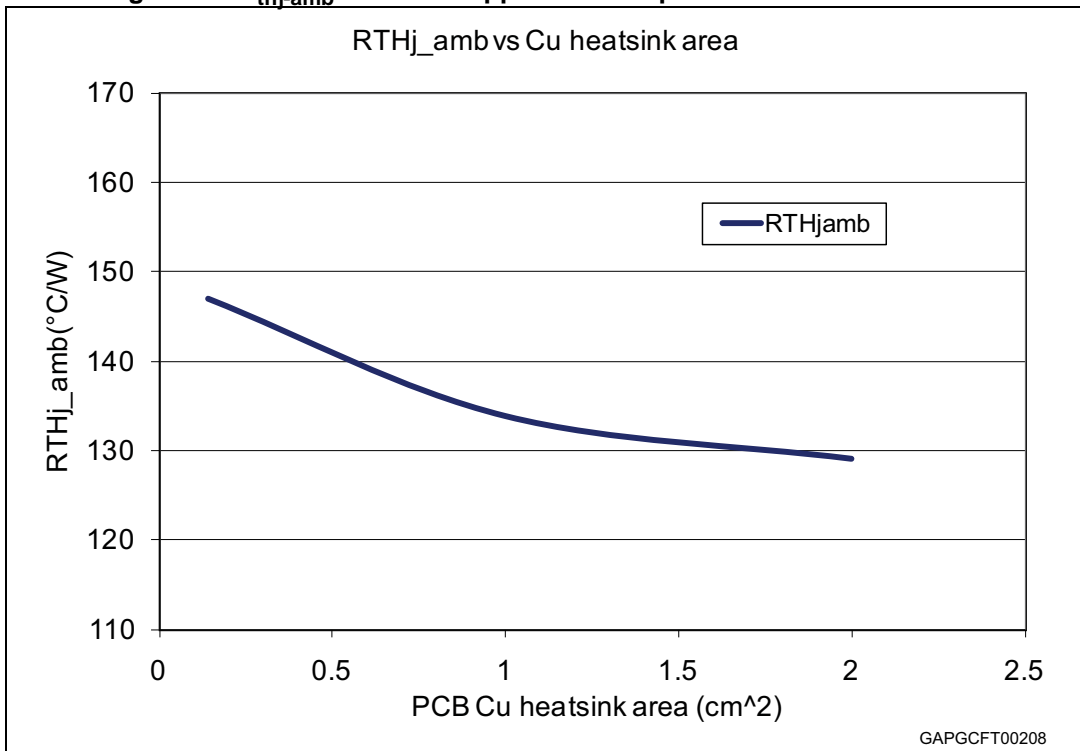
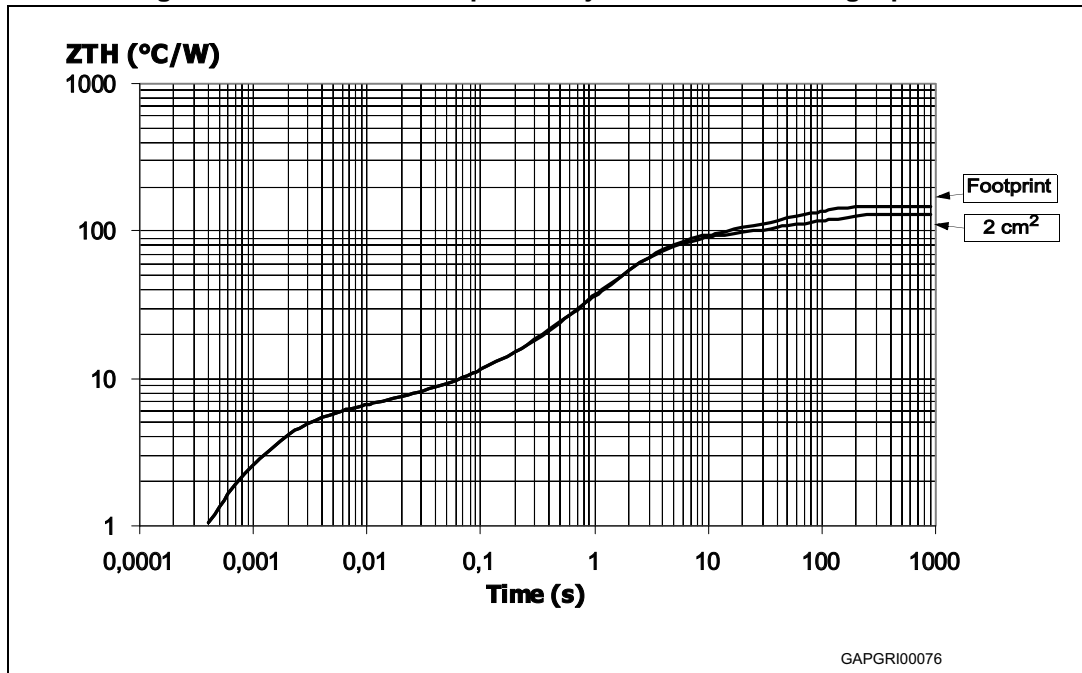


Figure 30. SO-8 thermal impedance junction ambient single pulse



Equation 1: pulse calculation formula

$$Z_{TH\delta} = R_{TH} \cdot \delta + Z_{THtp}(1 - \delta)$$

where  $\delta = t_p/T$

Figure 31. Thermal fitting model of Vreg in SO-8

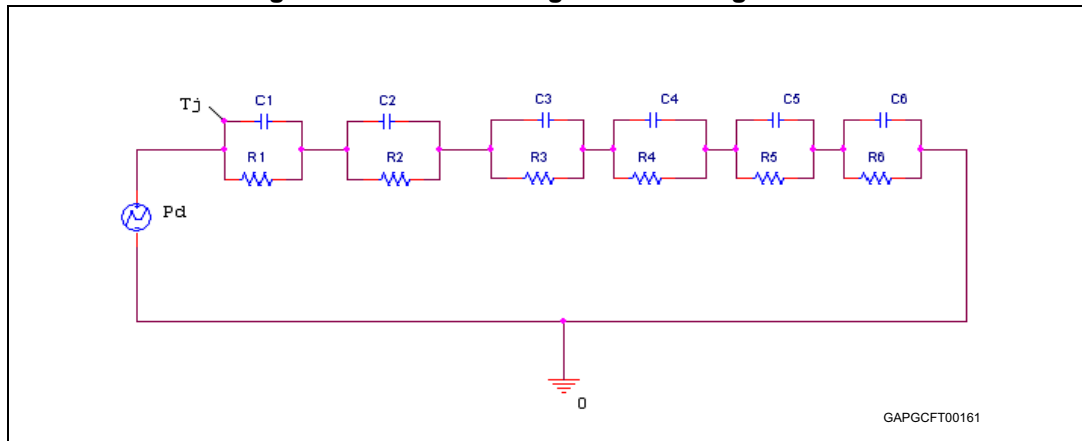
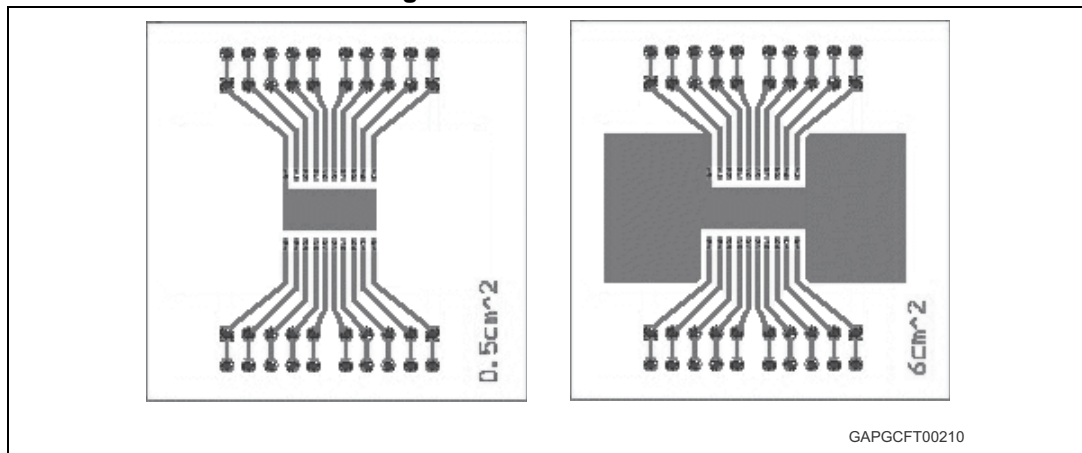


Table 9. SO-8 thermal parameter

Area/island (cm <sup>2</sup> )	Footprint	2
R1 (°C/W)	4.21	
R2 (°C/W)	2.11	
R3 (°C/W)	2	
R4 (°C/W)	41	
R5 (°C/W)	40	
R6 (°C/W)	58	40
C1 (W.s/°C)	0.00029	
C2 (W.s/°C)	0.0024	
C3 (W.s/°C)	0.03	
C4 (W.s/°C)	0.04	
C5 (W.s/°C)	0.1	
C6 (W.s/°C)	1.05	2

## 4.2 SO-20 thermal data

Figure 32. SO-20 PC board



Note: Layout condition of  $R_{th}$  and  $Z_{th}$  measurements (PCB FR4 area= 58mm x 58mm, PCB thickness = 2 mm, Cu thickness=35  $\mu$ m, Copper areas: from minimum pad lay-out to 6 cm<sup>2</sup>).

Figure 33.  $R_{thj-amb}$  Vs. PCB copper area in open box free air condition

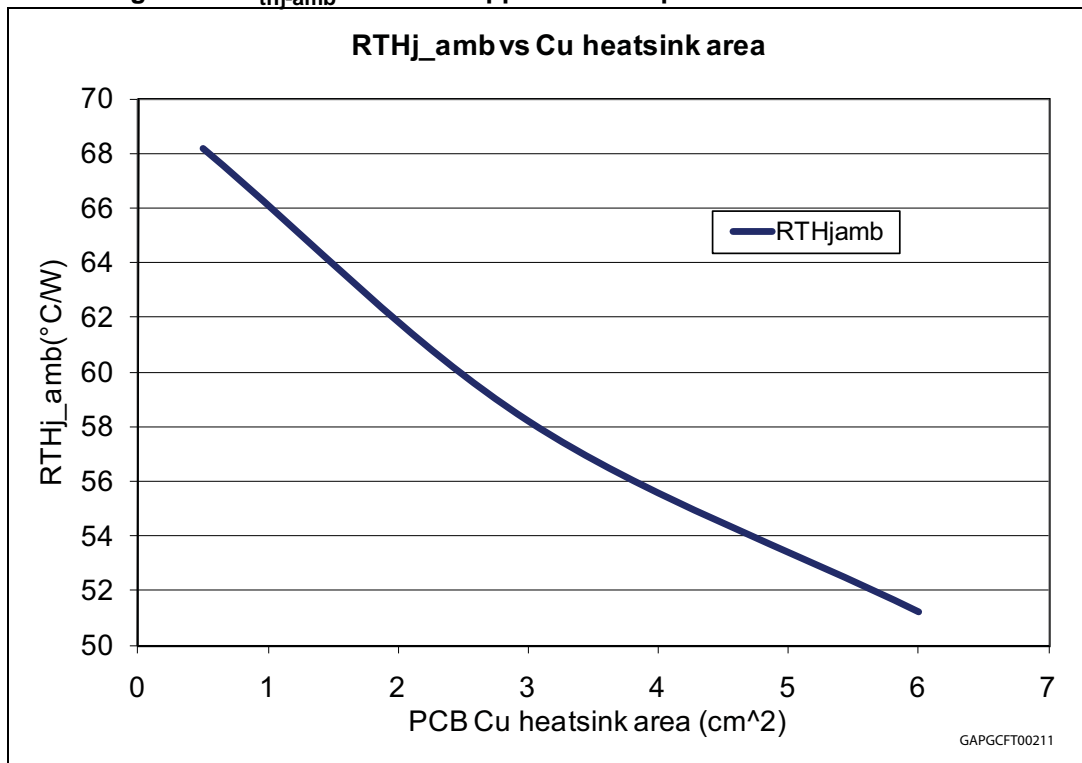
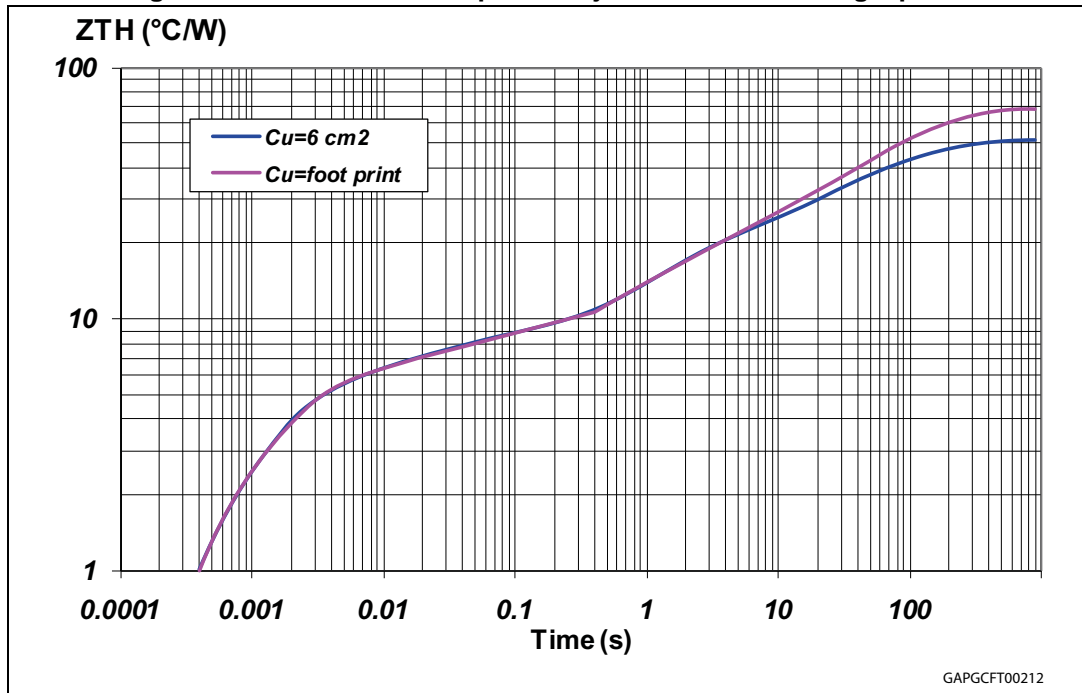


Figure 34. SO-20 thermal impedance junction ambient single pulse



Equation 2: pulse calculation formula

$$Z_{TH\delta} = R_{TH} \cdot \delta + Z_{THtp}(1 - \delta)$$

where  $\delta = t_p/T$

Figure 35. Thermal fitting model of Vreg in SO-20

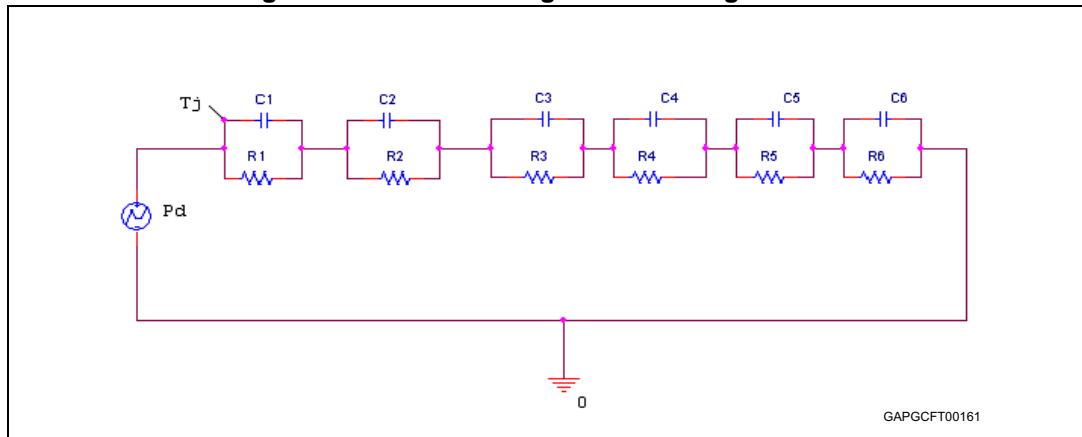


Table 10. SO-20 thermal parameter

Area/island (cm <sup>2</sup> )	Footprint	2
R1 (°C/W)	4.21	
R2 (°C/W)	2.11	
R3 (°C/W)	2.2	
R4 (°C/W)	10	
R5 (°C/W)	15	
R6 (°C/W)	35	18
C1 (W.s/°C)	0.00029	
C2 (W.s/°C)	0.0024	
C3 (W.s/°C)	0.015	
C4 (W.s/°C)	0.15	
C5 (W.s/°C)	1.5	
C6 (W.s/°C)	4	7

## 5 Package and packing information

### 5.1 ECOPACK®

In order to meet environmental requirements, ST offers these devices in different grades of ECOPACK® packages, depending on their level of environmental compliance. ECOPACK® specifications, grade definitions and product status are available at: [www.st.com](http://www.st.com). ECOPACK® is an ST trademark.

### 5.2 SO-8 package information

Figure 36. SO-8 package dimensions

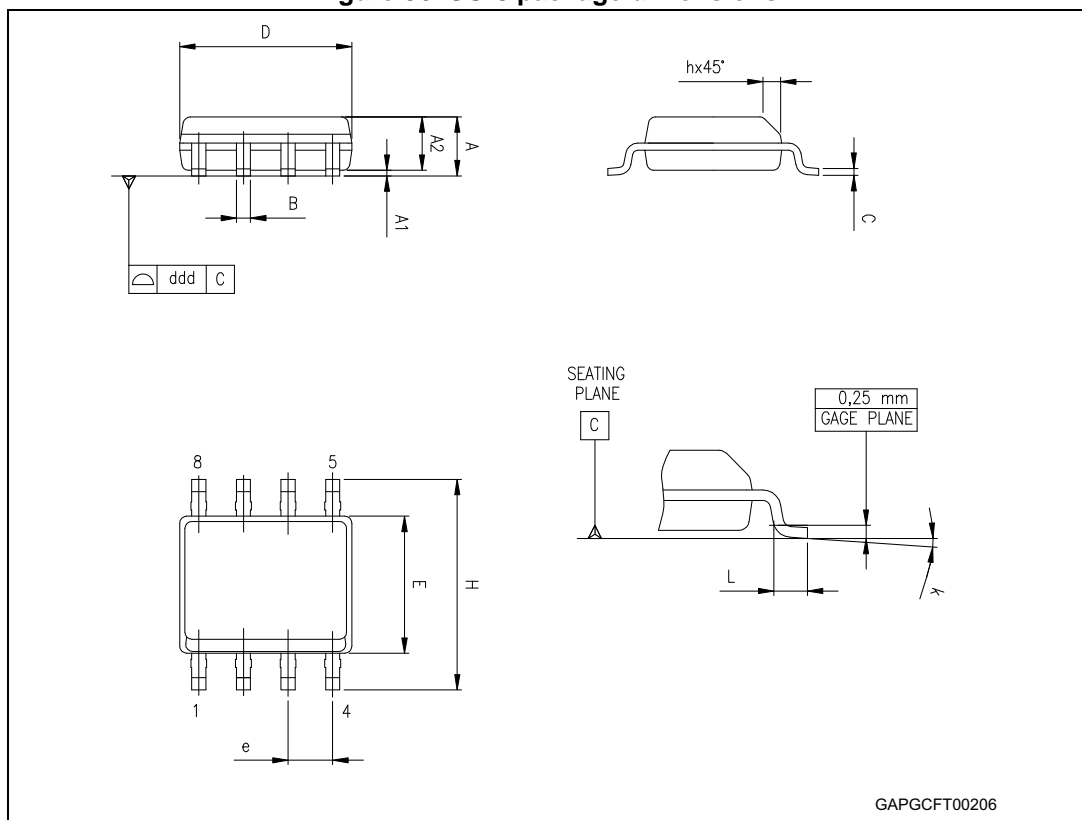


Table 11. SO-8 mechanical data

Symbol	Millimeters		
	Min.	Typ.	Max.
A			1.75
A1	0.10		0.25
A2	1.25		
b	0.28		0.48

Table 11. SO-8 mechanical data (continued)

Symbol	Millimeters		
	Min.	Typ.	Max.
c	0.17		0.23
D <sup>(1)</sup>	4.80	4.90	5.00
E	5.80	6.00	6.20
E1 <sup>(2)</sup>	3.80	3.90	4.00
e		1.27	
h	0.25		0.50
L	0.40		1.27
L1		1.04	
k	0°		8°
ccc			0.10

1. Dimensions D does not include mold flash, protrusions or gate burrs. Mold flash, protrusions or gate burrs shall not exceed 0.15 mm in total (both side).
2. Dimension "E1" does not include interlead flash or protrusions. Interlead flash or protrusions shall not exceed 0.25 mm per side.

### 5.3 SO-20 package information

Figure 37. SO-20 package dimensions

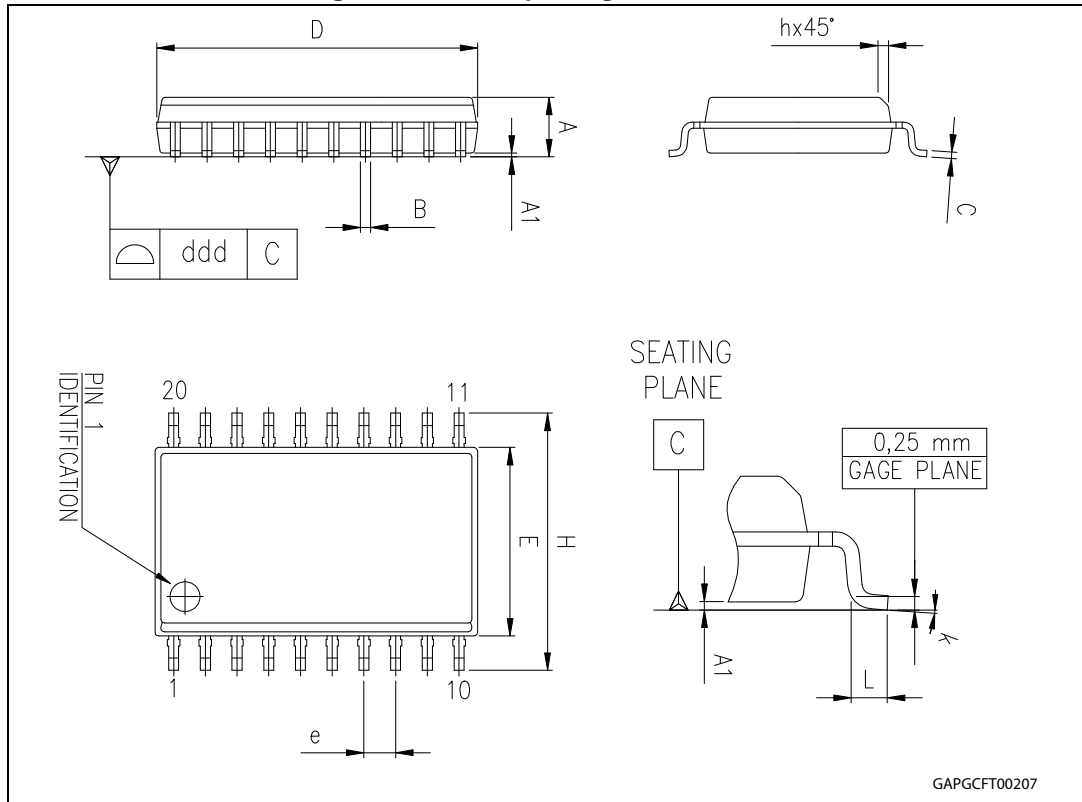


Table 12. SO-20 mechanical data

Symbol	Millimeters		
	Min.	Typ.	Max.
A	2.35		2.65
A1	0.10		0.30
B	0.33		0.51
C	0.23		0.32
D <sup>(1)</sup>	12.60		13.00
E	7.40		7.60
e		1.27	
H	10.0		10.65
h	0.25		0.75
L	0.40		1.27

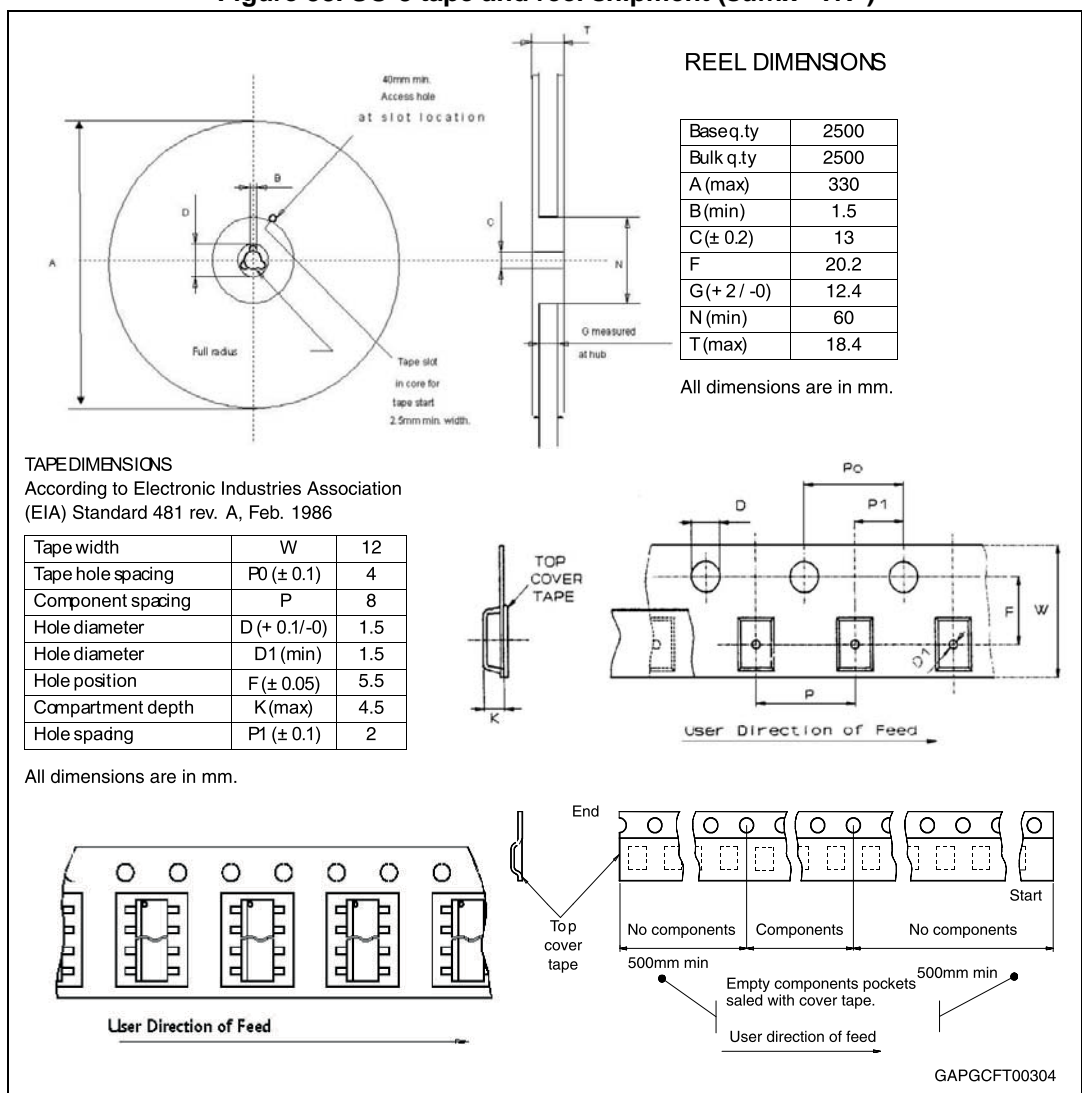
Table 12. SO-20 mechanical data (continued)

Symbol	Millimeters		
	Min.	Typ.	Max.
k	0°		8°
ddd			0.10

1. "D" dimension does not include mold flash, protrusions or gate burrs. Mold flash, protrusions or gate burrs shall not exceed 0.15mm per side.

### 5.4 SO-8 packing information

Figure 38. SO-8 tape and reel shipment (suffix "TR")



### 5.5 SO-20 packing information

Figure 39. SO-20 tube shipment (no suffix)

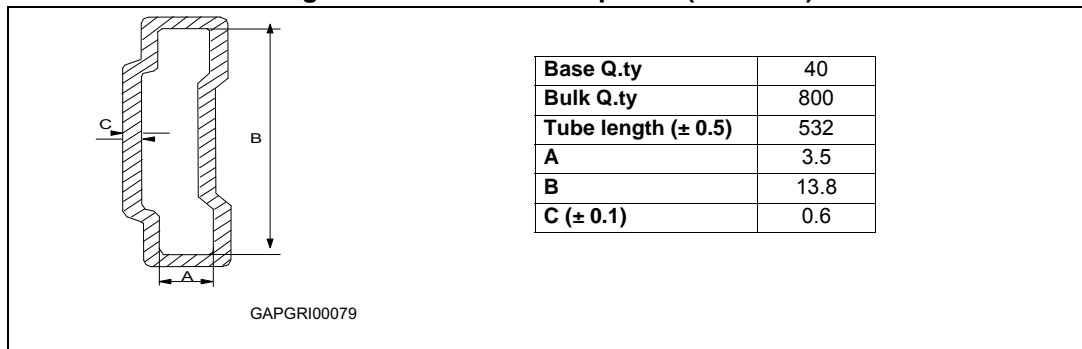
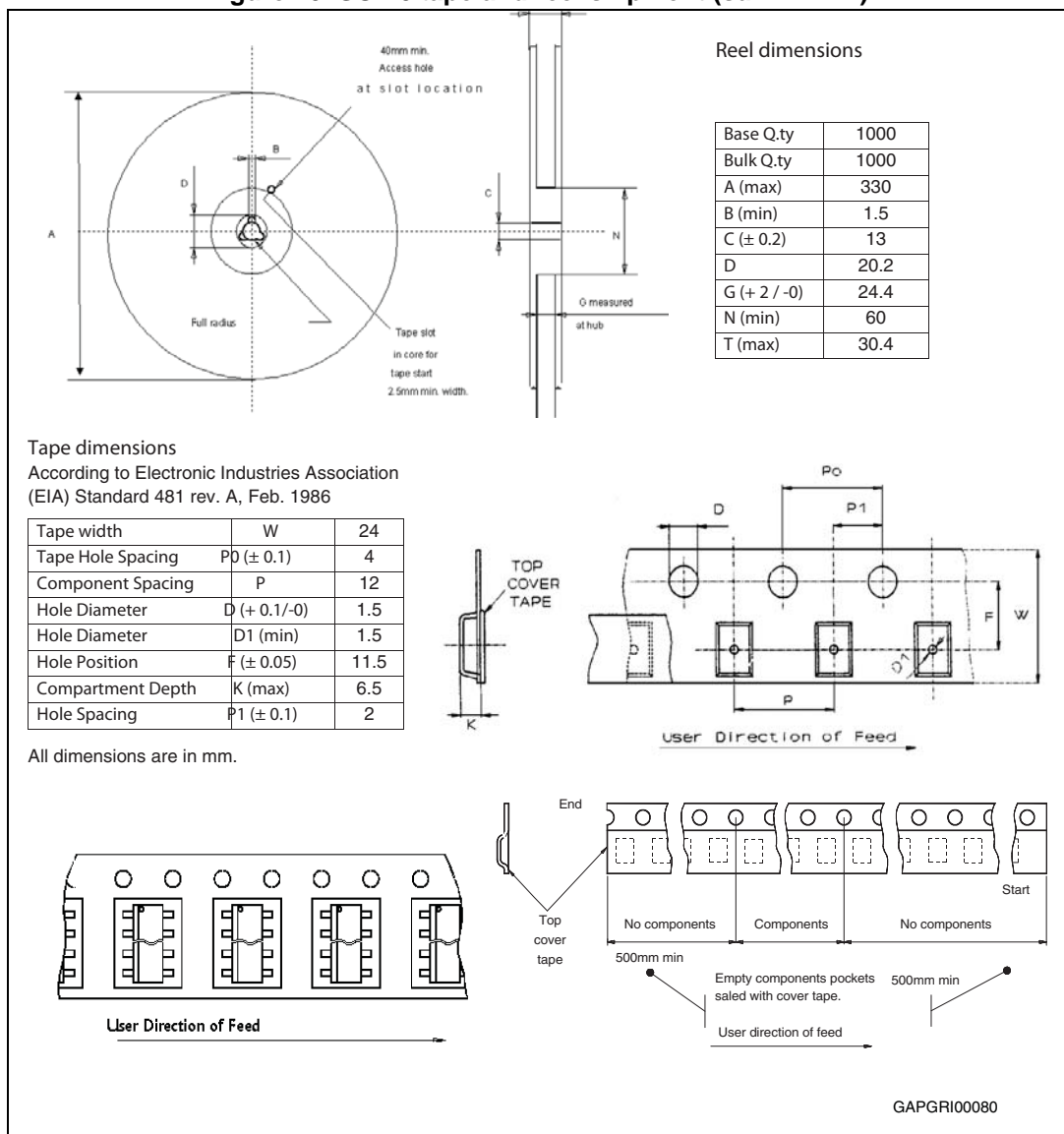


Figure 40. SO-20 tape and reel shipment (suffix “TR”)



## 6 Revision history

**Table 13. Document revision history**

Date	Revision	Changes
June-2004	1	Initial release.
18-Jan-2007	2	Updated <a href="#">Table 5</a> , <a href="#">6</a> , <a href="#">7</a> and <a href="#">8</a> .
01-Jun-2007	3	Document put in corporate technical literature template. Updated <a href="#">Table 4</a> .
22-Aug-2007	4	<a href="#">Table 5: General</a> : updated $I_{short}$ , $I_{lim}$ , $I_q$ , $T_{rr2}$ , $V_{th\_hist}$ parameters.
29-Aug-2007	5	Added list of tables and figures. Added <a href="#">Section 4: Package and PCB thermal data</a> .
08-Apr-2008	6	Document restructured. Changed <a href="#">Figure 1: Block diagram</a> . Updated <a href="#">Table 5: General</a> : <ul style="list-style-type: none"> <li>– changed <math>I_{short}</math> max value from 4000 mA to 400 mA</li> <li>– changed <math>I_{qn\_150}</math> typ. value from 1.45 mA to 1.25 mA</li> <li>– changed <math>I_{qn\_50}</math> typ. value from 538 <math>\mu</math>A to 470 <math>\mu</math>A</li> <li>– changed <math>I_{qn\_1}</math> typ. value from 120 <math>\mu</math>A to 100 <math>\mu</math>A.</li> </ul> Updated <a href="#">Table 6: Reset</a> . <ul style="list-style-type: none"> <li>– corrected trd formula.</li> </ul> Updated <a href="#">Table 7: Watchdog</a> : <ul style="list-style-type: none"> <li>– changed <math>V_{wlth}</math> values in <math>V_{o\_ref}</math> percentages</li> <li>– changed <math>V_{whth}</math> values in <math>V_{o\_ref}</math> percentages.</li> </ul> Added <a href="#">Figure 24: L4993 application schematic</a> . Added <a href="#">Section 2.4: Electrical characteristics curves</a> . Added <a href="#">Section 2.5: Test circuit and waveforms plot</a> .
09-Mar-2012	7	Updated <a href="#">Table 3: Absolute maximum ratings</a> .
20-Sep-2013	8	Updated disclaimer.
01-Mar-2018	9	Updated template. Removed the tube version on the SO-8 package on the <a href="#">Table 1: Device summary</a> . Updated <a href="#">Section 2.1: Absolute maximum ratings</a> . Removed Figure “SO-8 tube shipment (no suffix)”.
19-Sep-2018	10	Typo errors.

**IMPORTANT NOTICE – PLEASE READ CAREFULLY**

STMicroelectronics NV and its subsidiaries ("ST") reserve the right to make changes, corrections, enhancements, modifications, and improvements to ST products and/or to this document at any time without notice. Purchasers should obtain the latest relevant information on ST products before placing orders. ST products are sold pursuant to ST's terms and conditions of sale in place at the time of order acknowledgement.

Purchasers are solely responsible for the choice, selection, and use of ST products and ST assumes no liability for application assistance or the design of Purchasers' products.

No license, express or implied, to any intellectual property right is granted by ST herein.

Resale of ST products with provisions different from the information set forth herein shall void any warranty granted by ST for such product.

ST and the ST logo are trademarks of ST. All other product or service names are the property of their respective owners.

Information in this document supersedes and replaces information previously supplied in any prior versions of this document.

© 2018 STMicroelectronics – All rights reserved

## Looking for pricing, stock, or lifecycle information?

Click below to explore more details on WIN SOURCE:

-  [View L4993MDTR](#) on WIN SOURCE
-  [STMicroelectronics](#) Information

## Optimize Your Supply Chain with WIN SOURCE Solutions

-  Global Sourcing Solution
-  Obsolete Management
-  Cost Control Management
-  Shortage Management
-  Alternative Solution
-  Excess Inventory Management