



ON Semiconductor®

<http://onsemi.com>

LA5779

Monolithic Linear IC

Separately-excited Step-down Switching Regulator (Variable Type)

Overview

The LA5779 is a Separately-excited step-down switching regulator (variable type).

Functions

- High efficiency.
- Six external parts.
- Time-base generator (160kHz) incorporated.
- Current limiter incorporated.
- Thermal shutdown circuit incorporated.
- ON/OFF function.

Specifications

Absolute Maximum Ratings at $T_a = 25^\circ\text{C}$

Parameter	Symbol	Conditions	Ratings	Unit
Maximum Input voltage	$V_{IN\ max}$		30	V
Maximum Output current	$I_O\ max$		3	A
SW pin application reverse voltage	V_{SW}		-1	V
Allowable power dissipation	$P_d\ max1$	Infinitely large heat sink.	7.5	W
	$P_d\ max2$	Independent IC.	1.75	W
Operating temperature	T_{opr}		-30 to +125	$^\circ\text{C}$
Storage temperature	T_{stg}		-40 to +150	$^\circ\text{C}$
Junction temperature	$T_j\ max$		150	$^\circ\text{C}$

Stresses exceeding Maximum Ratings may damage the device. Maximum Ratings are stress ratings only. Functional operation above the Recommended Operating Conditions is not implied. Extended exposure to stresses above the Recommended Operating Conditions may affect device reliability.

Recommended Operating Conditions at $T_a = 25^\circ\text{C}$

Parameter	Symbol	Conditions	Ratings	Unit
Input voltage range	V_{IN}		4.5 to 28	V

LA5779

Electrical Characteristics at $T_a = 25^\circ\text{C}$, $V_O = 3.3\text{V}$

Parameter	Symbol	Conditions	Ratings			Unit
			min	typ	max	
Reference voltage	V_{OS}	$V_{IN} = 15\text{V}$, $I_O = 1.0\text{A}$	1.20	1.23	1.26	V
Efficiency	η	$V_{IN} = 15\text{V}$, $I_O = 1.0\text{A}$, Set $V_O = 5\text{V}$		84		%
Switching frequency	f	$V_{IN} = 15\text{V}$, $I_O = 1.0\text{A}$	128	160	192	kHz
Switching frequency when short-circuit protection is active	f_{short}	$V_{IN} = 15\text{V}$, $V_{OS} = 0\text{V}$	15	30	45	kHz
Line regulation	$\Delta V_{O\text{LINE}}$	$V_{IN} = 8$ to 20V , $I_O = 1.0\text{A}$		40	100	mV
Load regulation	$\Delta V_{O\text{LOAD}}$	$V_{IN} = 15\text{V}$, $I_O = 0.5$ to 1.5A		10	30	mV
Output voltage temperature coefficient	$\Delta V_O/\Delta T_a$	Designed target value. *		± 0.5		mV/°C
Ripple attenuation factor	RREJ	$f = 100$ to 120Hz		45		dB
Output leak current	$I_{O\text{leak}}$	$V_{IN} = 15\text{V}$, $SW_{OUT} = -0.4\text{V}$			50	μA
Current limiter operating voltage	I_S	$V_{IN} = 15\text{V}$	3.1			A
Operating current	I_{VIN}	$V_{IN} = 15\text{V}$		5.6		mA
Standby current	I_{STBY}	$V_{IN} = 15\text{V}$, $ENA = 5\text{V}$			200	μA
ENA pin LOW voltage range	V_{ENAL}				0.6	V
ENA pin HIGH voltage range	V_{ENAH}		2.4		V_{IN}	V
Thermal shutdown operating temperature	TSD	Designed target value. *		165		°C
Thermal shutdown Hysteresis width	ΔTSD	Designed target value. *		15		°C

* Design target value: No measurement made.

Package Dimensions

unit : mm (typ)

3079A

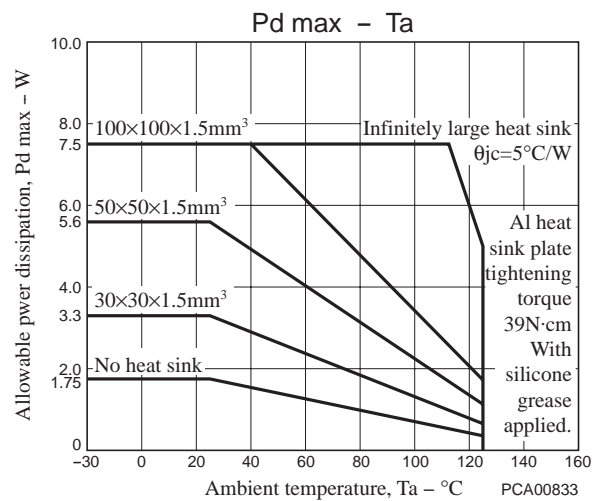
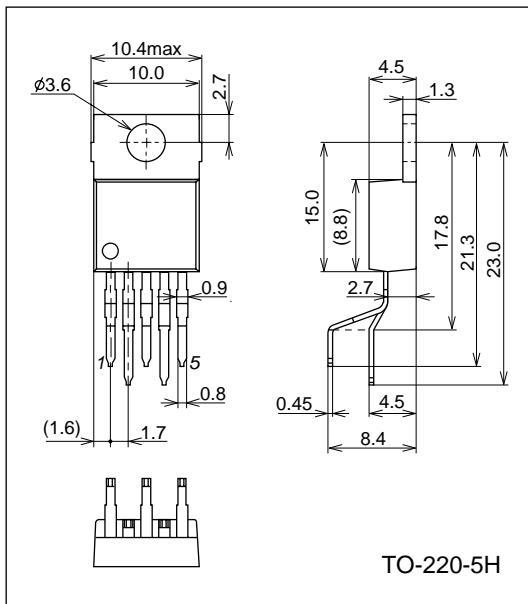

Pin Assignment

- (1) V_{IN} (2) SW_{OUT} (3) GND (4) V_{OS} (5) ENA

LA5779

Block Diagram

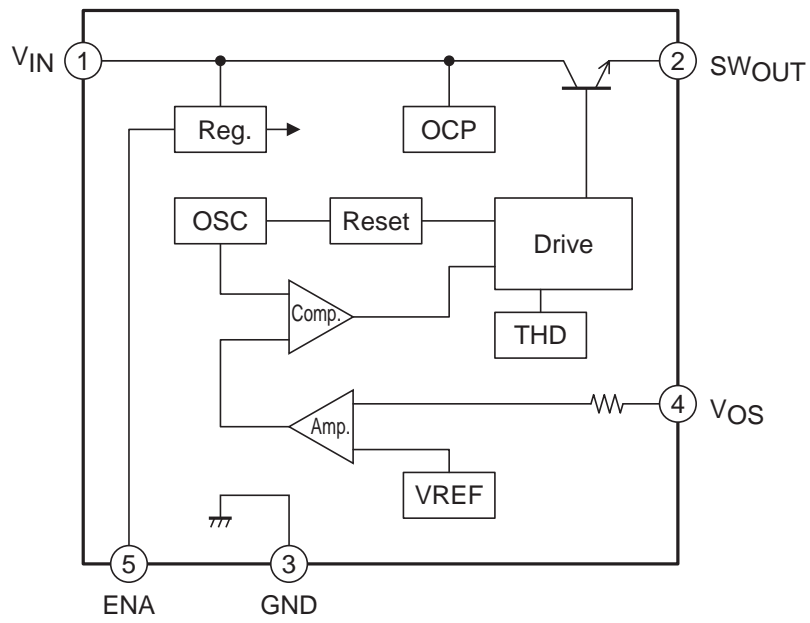

Application Circuit Example

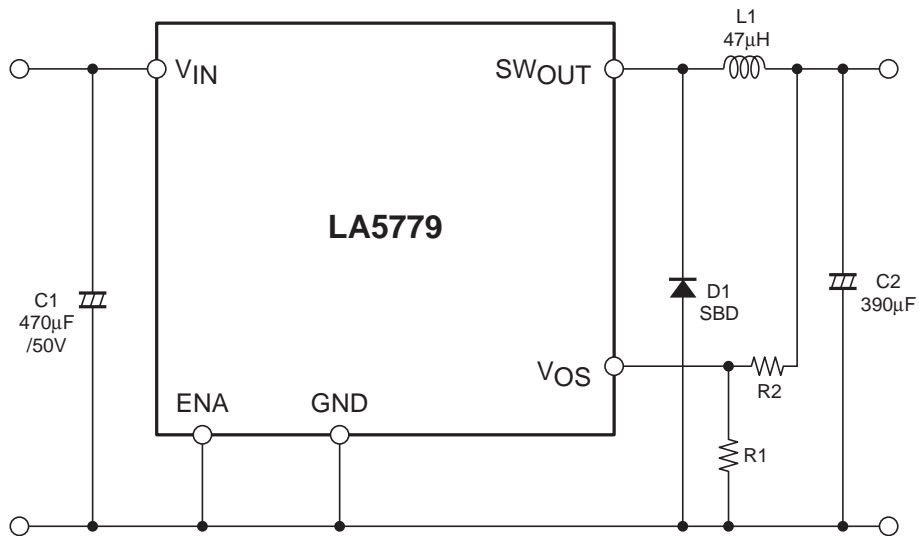

Description of Functional Settings

Calculation equation to set the output voltage

This IC controls the switching output so that the V_{OS} pin voltage becomes 1.23V (typ).

The equation to set the output voltage is as follows:

$$V_O = \left(1 + \frac{R_2}{R_1}\right) \times 1.23V(\text{typ})$$

The V_{OS} pin has the inrush current of 1 μ A (typ). Therefore, the error becomes larger when R1 and R2 resistance values are large.

ON Semiconductor and the ON logo are registered trademarks of Semiconductor Components Industries, LLC (SCILLC). SCILLC owns the rights to a number of patents, trademarks, copyrights, trade secrets, and other intellectual property. A listing of SCILLC's product/patent coverage may be accessed at www.onsemi.com/site/pdf/Patent-Marking.pdf. SCILLC reserves the right to make changes without further notice to any products herein. SCILLC makes no warranty, representation or guarantee regarding the suitability of its products for any particular purpose, nor does SCILLC assume any liability arising out of the application or use of any product or circuit, and specifically disclaims any and all liability, including without limitation special, consequential or incidental damages. "Typical" parameters which may be provided in SCILLC data sheets and/or specifications can and do vary in different applications and actual performance may vary over time. All operating parameters, including "Typicals" must be validated for each customer application by customer's technical experts. SCILLC does not convey any license under its patent rights nor the rights of others. SCILLC products are not designed, intended, or authorized for use as components in systems intended for surgical implant into the body, or other applications intended to support or sustain life, or for any other application in which the failure of the SCILLC product could create a situation where personal injury or death may occur. Should Buyer purchase or use SCILLC products for any such unintended or unauthorized application, Buyer shall indemnify and hold SCILLC and its officers, employees, subsidiaries, affiliates, and distributors harmless against all claims, costs, damages, and expenses, and reasonable attorney fees arising out of, directly or indirectly, any claim of personal injury or death associated with such unintended or unauthorized use, even if such claim alleges that SCILLC was negligent regarding the design or manufacture of the part. SCILLC is an Equal Opportunity/Affirmative Action Employer. This literature is subject to all applicable copyright laws and is not for resale in any manner.

Looking for pricing, stock, or lifecycle information?

Click below to explore more details on WIN SOURCE:

- ⊖ [View LA5779-HJ-E on WIN SOURCE](#)
- ⊖ [ON Semiconductor](#) Information

Optimize Your Supply Chain with WIN SOURCE Solutions

- ✓ Global Sourcing Solution
- ✓ Obsolete Management
- ✓ Cost Control Management
- ✓ Shortage Management
- ✓ Alternative Solution
- ✓ Excess Inventory Management