



**THE DATASHEET OF
LM150K STEEL/NOPB**



LM150/LM350A/LM350 3-Amp Adjustable Regulators

 Check for Samples: [LM150](#), [LM350-N](#), [LM350A](#)

FEATURES

- Adjustable Output Down to 1.2V
- Guaranteed 3A output Current
- Guaranteed Thermal Regulation
- Output is Short Circuit Protected
- Current Limit Constant with Temperature
- P+ Product Enhancement Tested
- 86 dB Ripple Rejection
- Ensured 1% Output Voltage Tolerance (LM350A)
- Ensured Max. 0.01%/V Line Regulation (LM350A)
- Ensured Max. 0.3% Load Regulation (LM350A)

APPLICATIONS

- Adjustable Power supplies
- Constant Current Regulators
- Battery Chargers

DESCRIPTION

The LM150 series of adjustable 3-terminal positive voltage regulators is capable of supplying in excess of 3A over a 1.2V to 33V output range. They are exceptionally easy to use and require only 2 external resistors to set the output voltage. Further, both line and load regulation are comparable to discrete designs. Also, the LM150 is packaged in standard transistor packages which are easily mounted and handled.

In addition to higher performance than fixed regulators, the LM150 series offers full overload protection available only in IC's. Included on the chip are current limit, thermal overload protection and safe area protection. All overload protection circuitry remains fully functional even if the adjustment terminal is accidentally disconnected.

Normally, no capacitors are needed unless the device is situated more than 6 inches from the input filter capacitors in which case an input bypass is needed. An output capacitor can be added to improve transient response, while bypassing the adjustment pin will increase the regulator's ripple rejection.

Besides replacing fixed regulators or discrete designs, the LM150 is useful in a wide variety of other applications. Since the regulator is "floating" and sees only the input-to-output differential voltage, supplies of several hundred volts can be regulated as long as the maximum input to output differential is not exceeded, i.e., avoid short-circuiting the output.

By connecting a fixed resistor between the adjustment pin and output, the LM150 can be used as a precision current regulator. Supplies with electronic shutdown can be achieved by clamping the adjustment terminal to ground which programs the output to 1.2V where most loads draw little current.

The part numbers in the LM150 series which have a NDS suffix are packaged in a standard Steel TO-3 package, while those with a NDE suffix are packaged in a TO-220 plastic package. The LM150 is rated for $-55^{\circ}\text{C} \leq T_J \leq +150^{\circ}\text{C}$, while the LM350A is rated for $-40^{\circ}\text{C} \leq T_J \leq +125^{\circ}\text{C}$, and the LM350 is rated for $0^{\circ}\text{C} \leq T_J \leq +125^{\circ}\text{C}$.

Connection Diagram

Case is Output

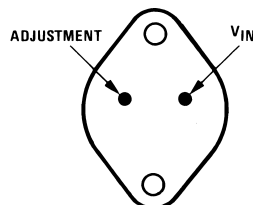

**Figure 1. (TO-3 STEEL) Metal Can Package
Bottom View
See Package Number NDS0002A**

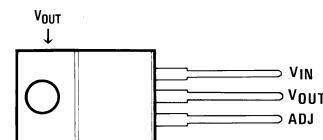

**Figure 2. (TO-220) Plastic Package
Front View
See Package Number NDE0003B**



Please be aware that an important notice concerning availability, standard warranty, and use in critical applications of Texas Instruments semiconductor products and disclaimers thereto appears at the end of this data sheet.

All trademarks are the property of their respective owners.



These devices have limited built-in ESD protection. The leads should be shorted together or the device placed in conductive foam during storage or handling to prevent electrostatic damage to the MOS gates.

Absolute Maximum Ratings⁽¹⁾⁽²⁾⁽³⁾

Power Dissipation		Internally Limited
Input-Output Voltage Differential		+35V
Storage Temperature		-65°C to +150°C
Lead Temperature	Metal Package (Soldering, 10 sec.)	300°C
	Plastic Package (Soldering, 4 sec.)	260°C
ESD Tolerance		TBD
Operating Temperature Range	LM150	-55°C ≤ T _J ≤ +150°C
	LM350A	-40°C ≤ T _J ≤ +125°C
	LM350	0°C ≤ T _J ≤ +125°C

- (1) Absolute Maximum Ratings indicate limits beyond which damage to the device may occur. Operating Ratings indicate conditions for which the device is intended to be functional, but do not ensure specific performance limits. For ensured specifications and test conditions, see the Electrical Characteristics.
- (2) Refer to RETS150K drawing for military specifications of the LM150K.
- (3) If Military/Aerospace specified devices are required, please contact the Texas Instruments Sales Office/ Distributors for availability and specifications.

Electrical Characteristics

Specifications with standard type face are for T_J = 25°C, and those with **boldface type** apply over **full Operating Temperature Range**. Unless otherwise specified, V_{IN} - V_{OUT} = 5V, and I_{OUT} = 10 mA⁽¹⁾

Parameter	Conditions	LM150			Units
		Min	Typ	Max	
Reference Voltage	3V ≤ (V _{IN} - V _{OUT}) ≤ 35V, 10 mA ≤ I _{OUT} ≤ 3A, P ≤ 30W	1.20	1.25	1.30	V
Line Regulation	3V ≤ (V _{IN} - V _{OUT}) ≤ 35V ⁽²⁾		0.005	0.01	%/V
			0.02	0.05	%/V
Load Regulation	10 mA ≤ I _{OUT} ≤ 3A ⁽²⁾		0.1	0.3	%
			0.3	1	%
Thermal Regulation	20 ms Pulse		0.002	0.01	%/W
Adjustment Pin Current			50	100	μA
Adjustment Pin Current Change	10 mA ≤ I _{OUT} ≤ 3A, 3V ≤ (V _{IN} - V _{OUT}) ≤ 35V		0.2	5	μA
Temperature Stability	T _{MIN} ≤ T _J ≤ T _{MAX}		1		%
Minimum Load Current	V _{IN} - V _{OUT} = 35V		3.5	5	mA
Current Limit	V _{IN} - V _{OUT} ≤ 10V	3.0	4.5		A
	V _{IN} - V _{OUT} = 30V	0.3	1		A
RMS Output Noise, % of V _{OUT}	10 Hz ≤ f ≤ 10 kHz		0.001		%
Ripple Rejection Ratio	V _{OUT} = 10V, f = 120 Hz, C _{ADJ} = 0 μF		65		dB
	V _{OUT} = 10V, f = 120 Hz, C _{ADJ} = 10 μF	66	86		dB
Long-Term Stability	T _J = 125°C, 1000 hrs		0.3	1	%
Thermal Resistance, Junction to Case	NDS Package		1.2	1.5	°C/W
Thermal Resistance, Junction to Ambient (No Heat Sink)	NDS Package		35		°C/W

- (1) These specifications are applicable for power dissipations up to 30W for the TO-3 (NDS) package and 25W for the TO-220 (NDE) package. Power dissipation is ensured at these values up to 15V input-output differential. Above 15V differential, power dissipation will be limited by internal protection circuitry. All limits (i.e., the numbers in the Min. and Max. columns) are ensured to AOQL (Average Outgoing Quality Level).
- (2) Regulation is measured at a constant junction temperature, using pulse testing with a low duty cycle. Changes in output voltage due to heating effects are covered under the specifications for thermal regulation.

Electrical Characteristics

Specifications with standard type face are for $T_J = 25^\circ\text{C}$, and those with **boldface type** apply over **full Operating Temperature Range**. Unless otherwise specified, $V_{IN} - V_{OUT} = 5\text{V}$, and $I_{OUT} = 10\text{ mA}$.⁽¹⁾

Parameter	Conditions	LM350A			LM350			Units
		Min	Typ	Max	Min	Typ	Max	
Reference Voltage	$I_{OUT} = 10\text{ mA}$, $T_J = 25^\circ\text{C}$ $3\text{V} \leq (V_{IN} - V_{OUT}) \leq 35\text{V}$, $10\text{ mA} \leq I_{OUT} \leq 3\text{A}$, $P \leq 30\text{W}$	1.238	1.250	1.262				V
		1.225	1.250	1.270	1.20	1.25	1.30	V
Line Regulation	$3\text{V} \leq (V_{IN} - V_{OUT}) \leq 35\text{V}^{(2)}$		0.005	0.01		0.005	0.03	%/V
			0.02	0.05		0.02	0.07	%/V
Load Regulation	$10\text{ mA} \leq I_{OUT} \leq 3\text{A}^{(2)}$		0.1	0.3		0.1	0.5	%
			0.3	1		0.3	1.5	%
Thermal Regulation	20 ms Pulse		0.002	0.01		0.002	0.03	%/W
Adjustment Pin Current			50	100		50	100	μA
Adjustment Pin Current Change	$10\text{ mA} \leq I_{OUT} \leq 3\text{A}$, $3\text{V} \leq (V_{IN} - V_{OUT}) \leq 35\text{V}$		0.2	5		0.2	5	μA
Temperature Stability	$T_{MIN} \leq T_J \leq T_{MAX}$		1			1		%
Minimum Load Current	$V_{IN} - V_{OUT} = 35\text{V}$		3.5	10		3.5	10	mA
Current Limit	$V_{IN} - V_{OUT} \leq 10\text{V}$	3.0	4.5		3.0	4.5		A
	$V_{IN} - V_{OUT} = 30\text{V}$	0.3	1		0.25	1		A
RMS Output Noise, % of V_{OUT}	$10\text{ Hz} \leq f \leq 10\text{ kHz}$		0.001			0.001		%
Ripple Rejection Ratio	$V_{OUT} = 10\text{V}$, $f = 120\text{ Hz}$, $C_{ADJ} = 0\text{ }\mu\text{F}$		65			65		dB
	$V_{OUT} = 10\text{V}$, $f = 120\text{ Hz}$, $C_{ADJ} = 10\text{ }\mu\text{F}$	66	86		66	86		dB
Long-Term Stability	$T_J = 125^\circ\text{C}$, 1000 hrs		0.25	1		0.25	1	%
Thermal Resistance, Junction to Case	NDS Package					1.2	1.5	$^\circ\text{C/W}$
	NDE Package		3	4		3	4	$^\circ\text{C/W}$
Thermal Resistance, Junction to Ambient (No Heat Sink)	NDS Package					35		$^\circ\text{C/W}$
	NDE Package		50			50		$^\circ\text{C/W}$

- (1) These specifications are applicable for power dissipations up to 30W for the TO-3 (NDS) package and 25W for the TO-220 (NDE) package. Power dissipation is ensured at these values up to 15V input-output differential. Above 15V differential, power dissipation will be limited by internal protection circuitry. All limits (i.e., the numbers in the Min. and Max. columns) are ensured to AOQL (Average Outgoing Quality Level).
- (2) Regulation is measured at a constant junction temperature, using pulse testing with a low duty cycle. Changes in output voltage due to heating effects are covered under the specifications for thermal regulation.

Typical Performance Characteristics

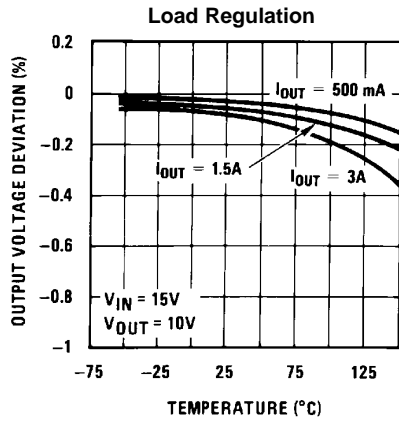

Figure 3.

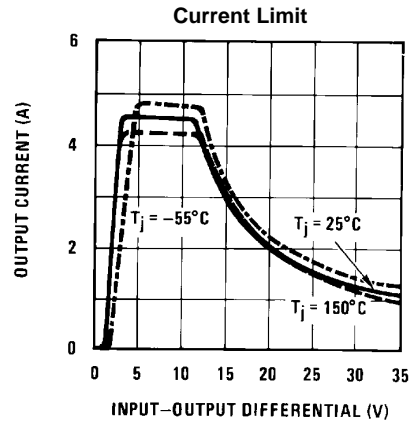

Figure 4.

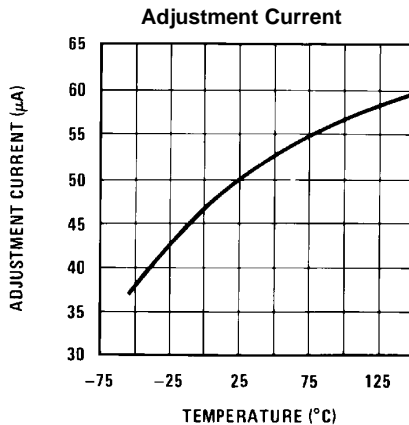

Figure 5.

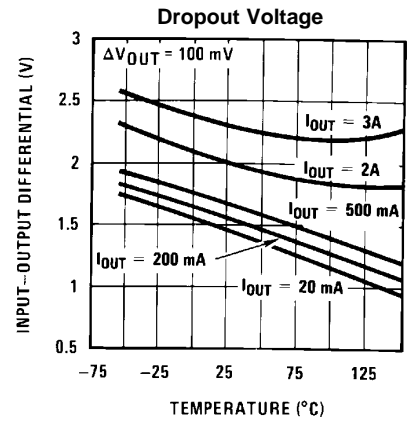

Figure 6.

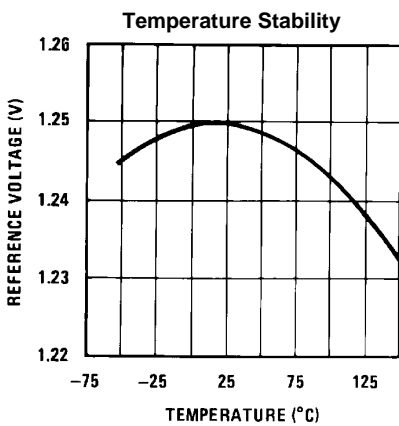

Figure 7.

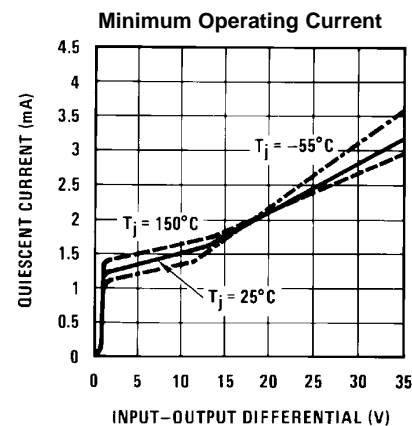

Figure 8.

Typical Performance Characteristics (continued)

Ripple Rejection

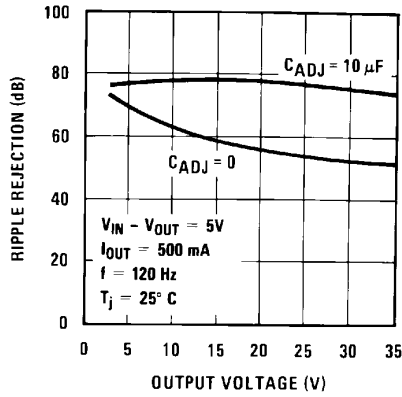

Figure 9.

Ripple Rejection

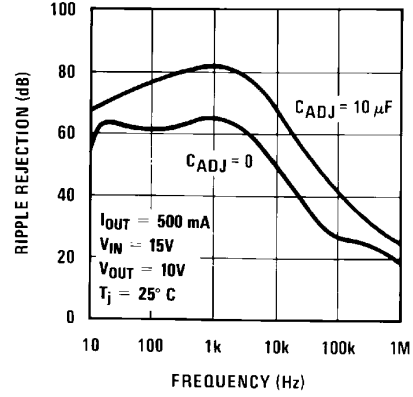

Figure 10.

Ripple Rejection

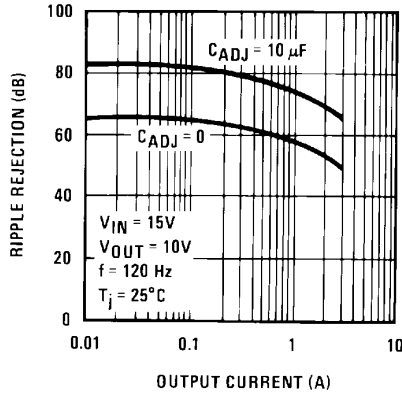

Figure 11.

Output Impedance

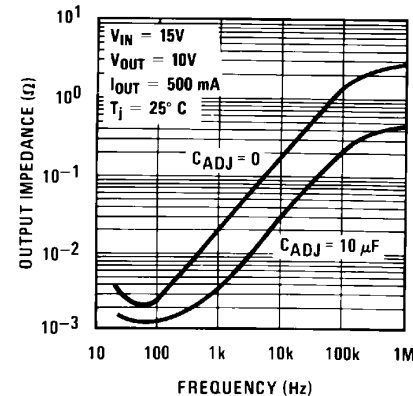

Figure 12.

Line Transient Response

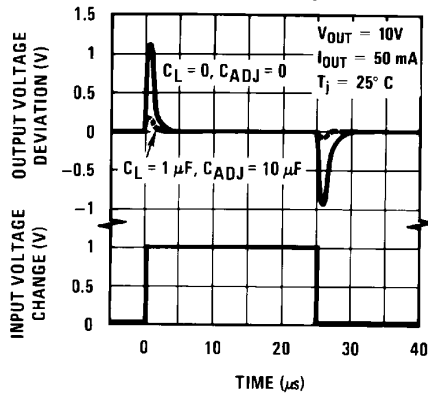

Figure 13.

Load Transient Response

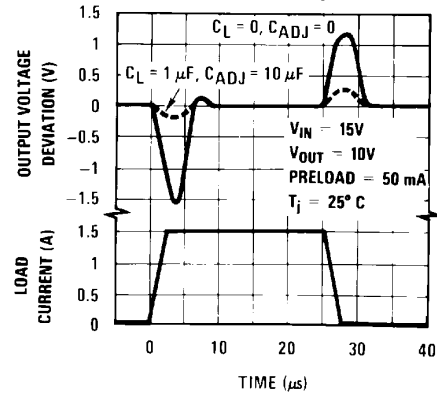

Figure 14.

APPLICATION HINTS

In operation, the LM150 develops a nominal 1.25V reference voltage, V_{REF} , between the output and adjustment terminal. The reference voltage is impressed across program resistor $R1$ and, since the voltage is constant, a constant current I_1 then flows through the output set resistor $R2$, giving an output voltage of

$$V_{OUT} = V_{REF} \left(1 + \frac{R2}{R1} \right) + I_{ADJ} R2. \quad (1)$$

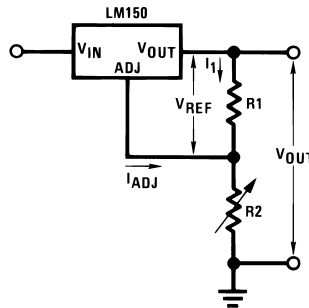

Figure 15.

Since the 50 μ A current from the adjustment terminal represents an error term, the LM150 was designed to minimize I_{ADJ} and make it very constant with line and load changes. To do this, all quiescent operating current is returned to the output establishing a minimum load current requirement. If there is insufficient load on the output, the output will rise.

EXTERNAL CAPACITORS

An input bypass capacitor is recommended. A 0.1 μ F disc or 1 μ F solid tantalum on the input is suitable input bypassing for almost all applications. The device is more sensitive to the absence of input bypassing when adjustment or output capacitors are used but the above values will eliminate the possibility of problems.

The adjustment terminal can be bypassed to ground on the LM150 to improve ripple rejection. This bypass capacitor prevents ripple from being amplified as the output voltage is increased. With a 10 μ F bypass capacitor 86 dB ripple rejection is obtainable at any output level. Increases over 10 μ F do not appreciably improve the ripple rejection at frequencies above 120 Hz. If the bypass capacitor is used, it is sometimes necessary to include protection diodes to prevent the capacitor from discharging through internal low current paths and damaging the device.

In general, the best type of capacitors to use is solid tantalum. Solid tantalum capacitors have low impedance even at high frequencies. Depending upon capacitor construction, it takes about 25 μ F in aluminum electrolytic to equal 1 μ F solid tantalum at high frequencies. Ceramic capacitors are also good at high frequencies, but some types have a large decrease in capacitance at frequencies around 0.5 MHz. For this reason, 0.01 μ F disc may seem to work better than a 0.1 μ F disc as a bypass.

Although the LM150 is stable with no output capacitors, like any feedback circuit, certain values of external capacitance can cause excessive ringing. This occurs with values between 500 pF and 5000 pF. A 1 μ F solid tantalum (or 25 μ F aluminum electrolytic) on the output swamps this effect and insures stability.

LOAD REGULATION

The LM150 is capable of providing extremely good load regulation but a few precautions are needed to obtain maximum performance. The current set resistor connected between the adjustment terminal and the output terminal (usually 240 Ω) should be tied directly to the output (case) of the regulator rather than near the load. This eliminates line drops from appearing effectively in series with the reference and degrading regulation. For example, a 15V regulator with 0.05 Ω resistance between the regulator and load will have a load regulation due to line resistance of $0.05\Omega \times I_{OUT}$. If the set resistor is connected near the load the effective line resistance will be $0.05\Omega (1 + R2/R1)$ or in this case, 11.5 times worse.

Figure 16 shows the effect of resistance between the regulator and 240 Ω set resistor.

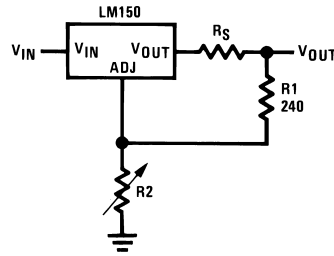

Figure 16. Regulator with Line Resistance in Output Lead

With the TO-3 package, it is easy to minimize the resistance from the case to the set resistor, by using two separate leads to the case. The ground of R2 can be returned near the ground of the load to provide remote ground sensing and improve load regulation.

PROTECTION DIODES

When external capacitors are used with *any* IC regulator it is sometimes necessary to add protection diodes to prevent the capacitors from discharging through low current points into the regulator. Most 10 μF capacitors have low enough internal series resistance to deliver 20A spikes when shorted. Although the surge is short, there is enough energy to damage parts of the IC.

When an output capacitor is connected to a regulator and the input is shorted, the output capacitor will discharge into the output of the regulator. The discharge current depends on the value of the capacitor, the output voltage of the regulator, and the rate of decrease of V_{IN} . In the LM150, this discharge path is through a large junction that is able to sustain 25A surge with no problem. This is not true of other types of positive regulators. For output capacitors of 25 μF or less, there is no need to use diodes.

The bypass capacitor on the adjustment terminal can discharge through a low current junction. Discharge occurs when *either* the input or output is shorted. Internal to the LM150 is a 50 Ω resistor which limits the peak discharge current. No protection is needed for output voltages of 25V or less and 10 μF capacitance. Figure 17 shows an LM150 with protection diodes included for use with outputs greater than 25V and high values of output capacitance.

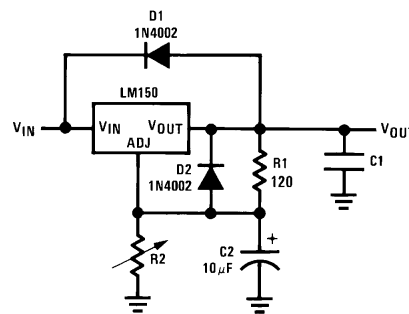

D1 protects against C1
D2 protects against C2

Figure 17. Regulator with Protection Diodes

$$V_{\text{OUT}} = 1.25\text{V} \left(1 + \frac{R_2}{R_1} \right) + I_{\text{ADJ}}R_2 \quad (2)$$

Schematic Diagram

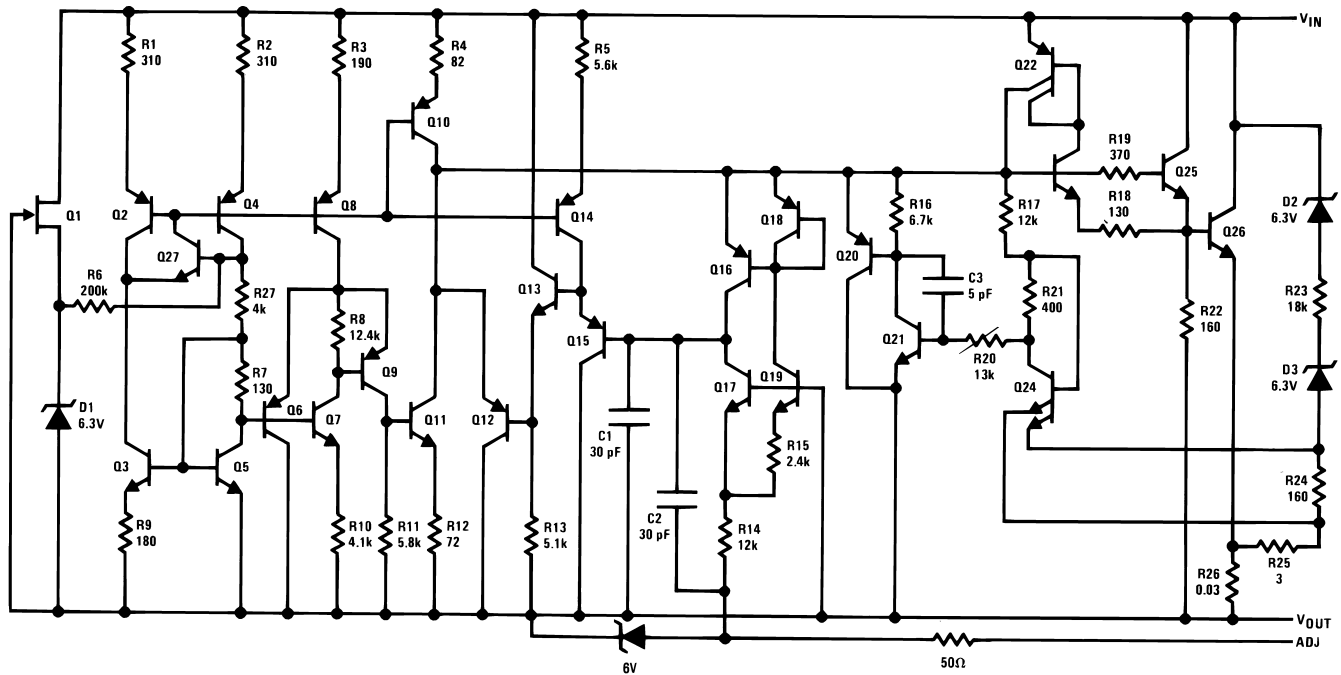
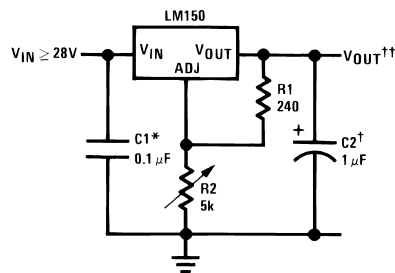

Figure 18. Schematic Diagram

Typical Applications



Full output current not available at high input-output voltages.

†Optional—improves transient response. Output capacitors in the range of 1 μF to 1000 μF of aluminum or tantalum electrolytic are commonly used to provide improved output impedance and rejection of transients.

*Needed if device is more than 6 inches from filter capacitors.

Figure 19. 1.2V–25V Adjustable Regulator

$$††V_{OUT} = 1.25V \left(1 + \frac{R2}{R1} \right) + I_{ADJ}(R2)$$

Note: Usually R1 = 240Ω for LM150 and R1 = 120Ω for LM350.

(3)

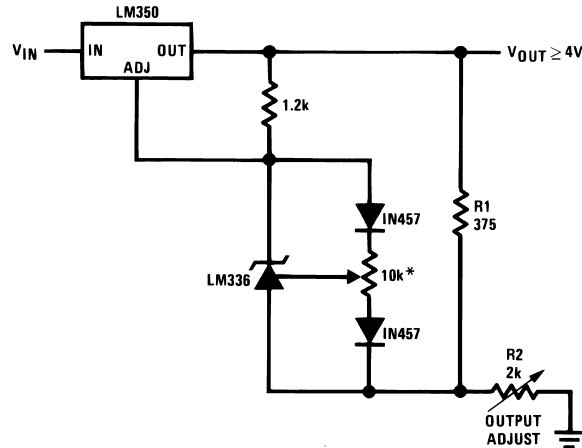

*Adjust for 3.75V across R1

Figure 20. Precision Power Regulator with Low Temperature Coefficient

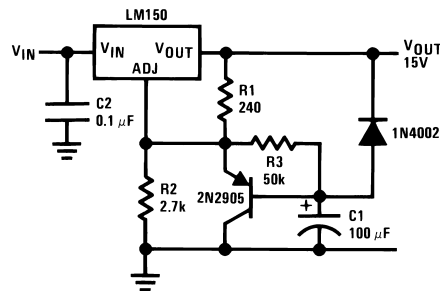
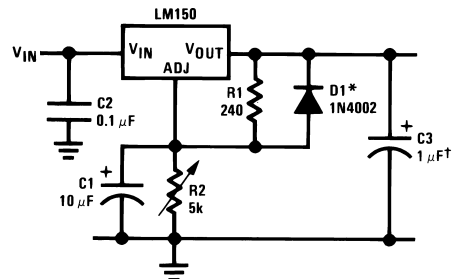

Figure 21. Slow Turn-ON 15V Regulator



†Solid tantalum

*Discharges C1 if output is shorted to ground

Figure 22. Adjustable Regulator with Improved Ripple Rejection

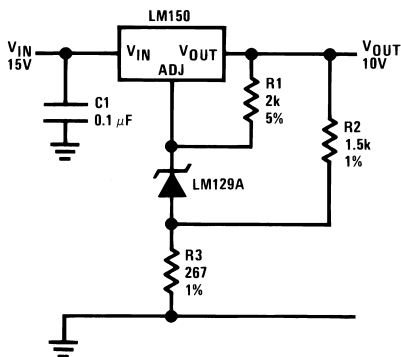
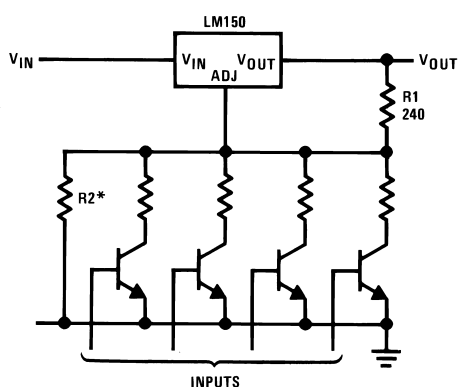

Figure 23. High Stability 10V Regulator



*Sets maximum V_{OUT}

Figure 24. Digitally Selected Outputs

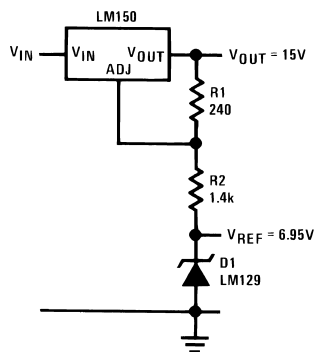
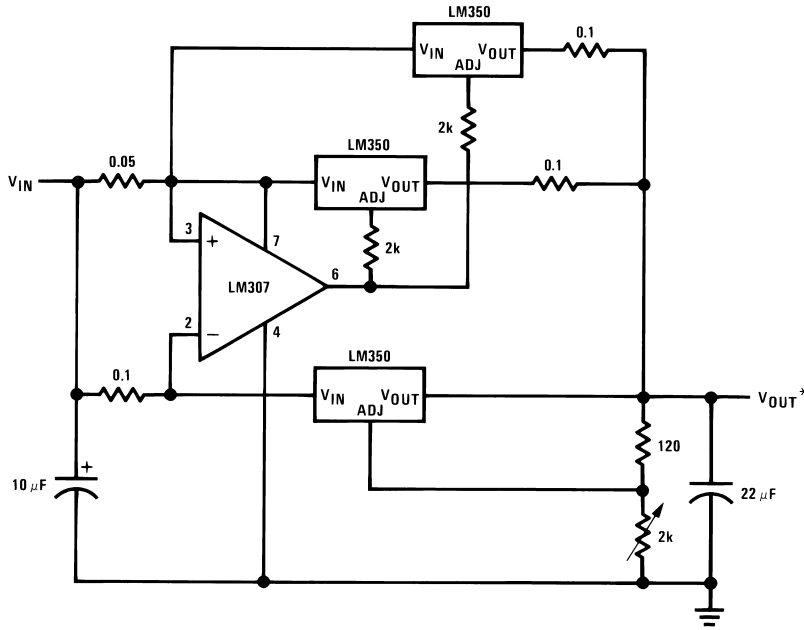
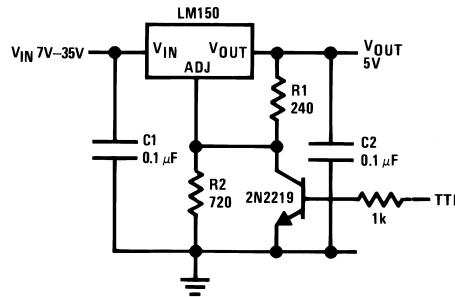

Figure 25. Regulator and Voltage Reference



*Minimum load current 50 mA

Figure 26. 10A Regulator



*Min output \approx 1.2V

Figure 27. 5V Logic Regulator with Electronic Shutdown*

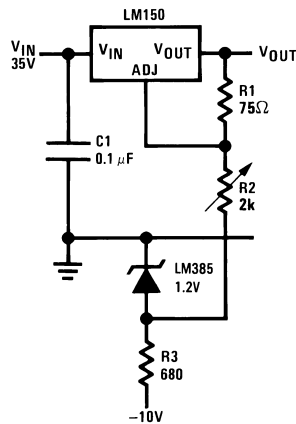

Full output current not available at high input-output voltages

Figure 28. 0 to 30V Regulator

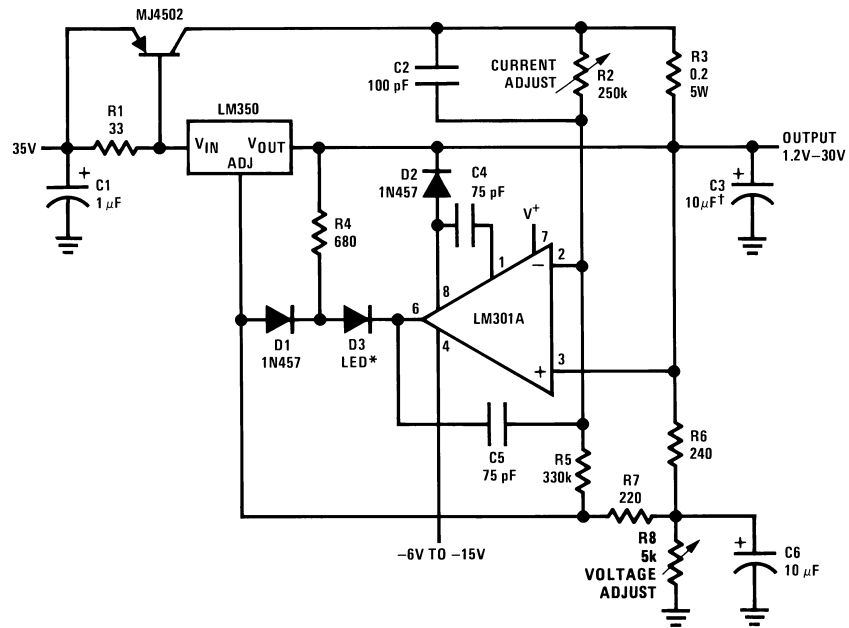

†Solid tantalum

*Lights in constant current mode

Figure 29. 5A Constant Voltage/Constant Current Regulator

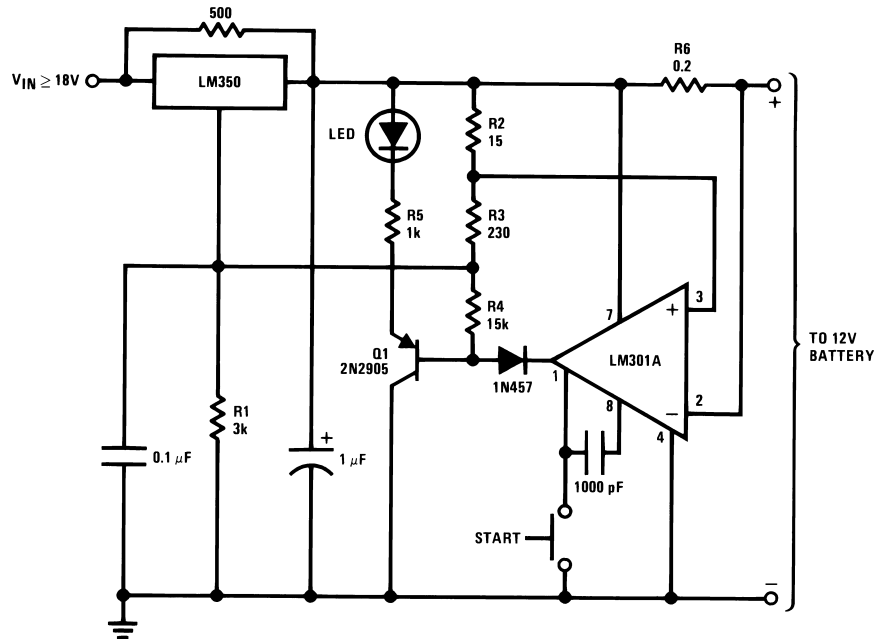

Figure 30. 12V Battery Charger

* $0.4 \leq R_1 \leq 120\Omega$

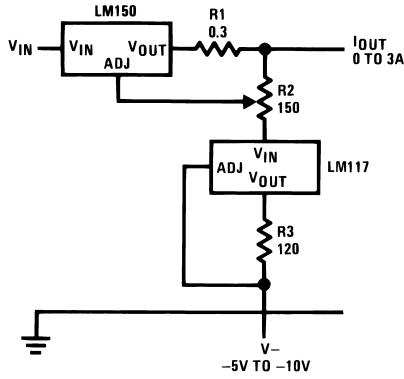

Figure 31. Adjustable Current Regulator

*Minimum output current \approx 4 mA

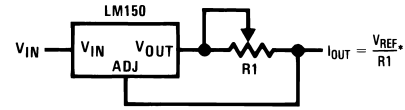

Figure 32. Precision Current Limiter

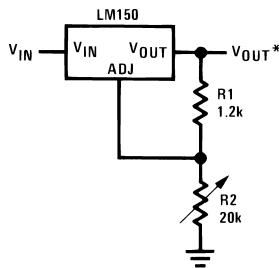

Figure 33. 1.2V–20V Regulator with Minimum Program Current

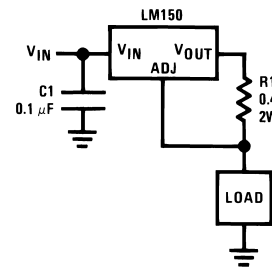

Figure 34. 3A Current Regulator

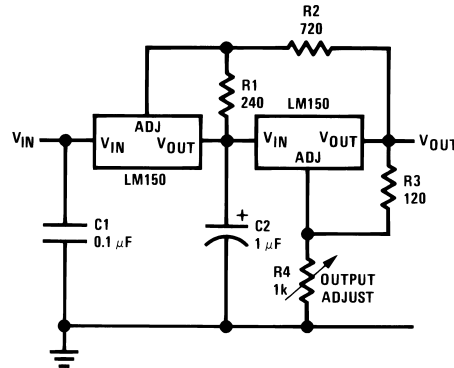
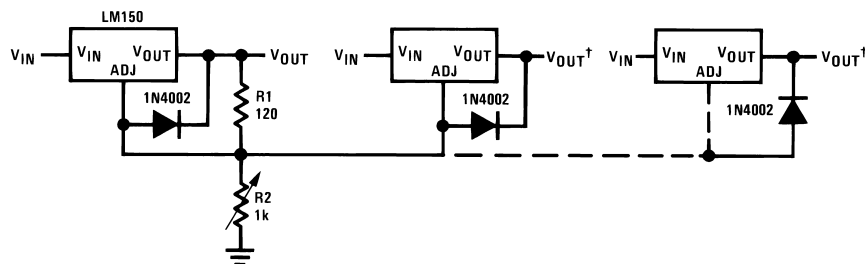

Figure 35. Tracking Preregulator



†Minimum load—10 mA
*All outputs within \pm 100 mV

Figure 36. Adjusting Multiple On-Card Regulators with Single Control*

* R_S —sets output impedance of charger: $Z_{OUT} = R_S \left(1 + \frac{R_2}{R_1} \right)$

Use of R_S allows low charging rates with fully charged battery.

**1000 μF is recommended to filter out any input transients

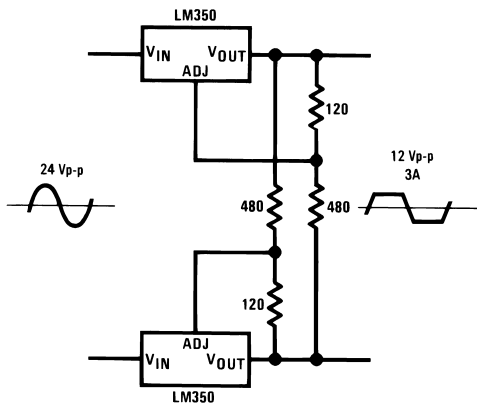

Figure 37. AC Voltage Regulator

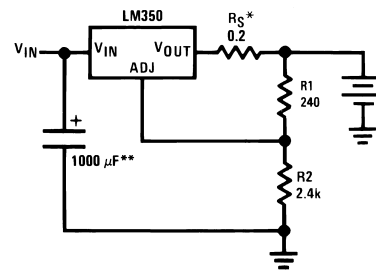

Figure 38. Simple 12V Battery Charger

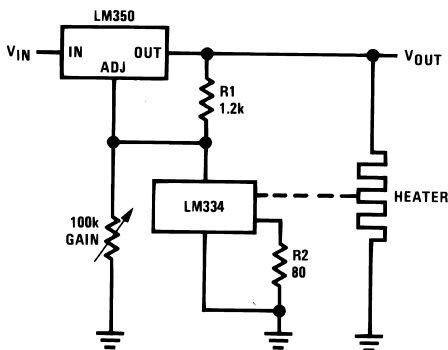

Figure 39. Temperature Controller

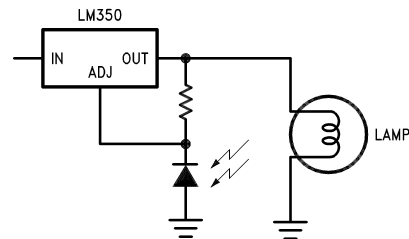

Figure 40. Light Controller

*Sets peak current (2A for 0.3 Ω)

**1000 μF is recommended to filter out any input transients.

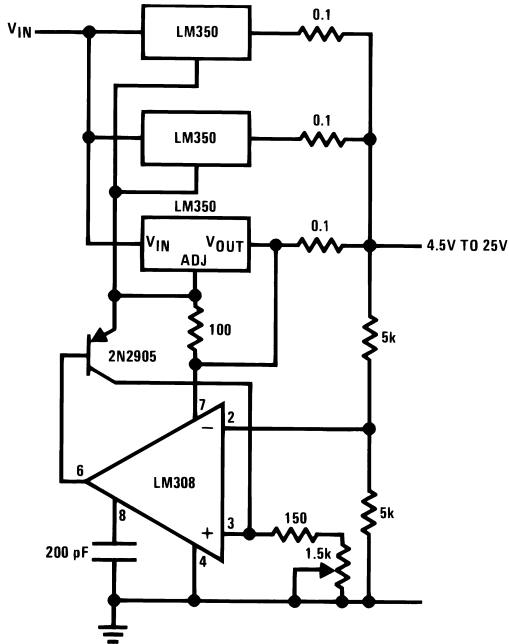

Figure 41. Adjustable 10A Regulator

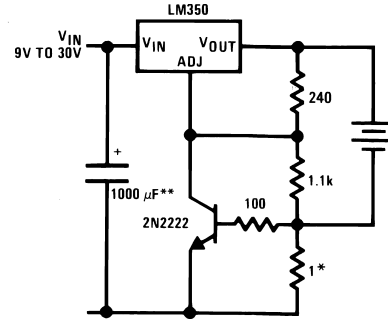

Figure 42. Current Limited 6V Charger

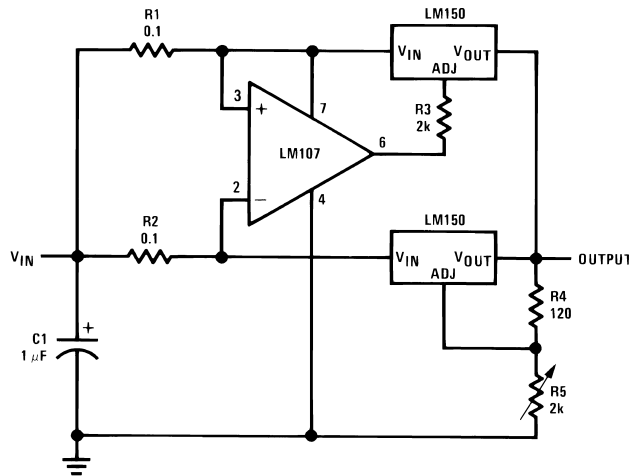

Figure 43. 6A Regulator

REVISION HISTORY

Changes from Revision A (March 2013) to Revision B	Page
• Changed layout of National Data Sheet to TI format	15

PACKAGING INFORMATION

Orderable Device	Status (1)	Package Type	Package Drawing	Pins	Package Qty	Eco Plan (2)	Lead/Ball Finish (6)	MSL Peak Temp (3)	Op Temp (°C)	Device Marking (4/5)	Samples
LM350A MWC	ACTIVE	WAFERSALE	YS	0	1	Green (RoHS & no Sb/Br)	Call TI	Level-1-NA-UNLIM	-40 to 85		Samples
LM350AT	NRND	TO-220	NDE	3	45	TBD	Call TI	Call TI	-40 to 125	LM350AT P+	
LM350AT/NOPB	ACTIVE	TO-220	NDE	3	45	Green (RoHS & no Sb/Br)	CU SN	Level-1-NA-UNLIM	-40 to 125	LM350AT P+	Samples
LM350K STEEL	ACTIVE	TO-3	NDS	2	50	TBD	Call TI	Call TI	0 to 125	LM350K STEELP+	Samples
LM350K STEEL/NOPB	ACTIVE	TO-3	NDS	2	50	Green (RoHS & no Sb/Br)	Call TI	Level-1-NA-UNLIM	0 to 125	LM350K STEELP+	Samples
LM350T	NRND	TO-220	NDE	3	45	TBD	Call TI	Call TI	0 to 125	LM350T P+	
LM350T/NOPB	ACTIVE	TO-220	NDE	3	45	Green (RoHS & no Sb/Br)	CU SN	Level-1-NA-UNLIM	0 to 125	LM350T P+	Samples

(1) The marketing status values are defined as follows:

ACTIVE: Product device recommended for new designs.

LIFEBUY: TI has announced that the device will be discontinued, and a lifetime-buy period is in effect.

NRND: Not recommended for new designs. Device is in production to support existing customers, but TI does not recommend using this part in a new design.

PREVIEW: Device has been announced but is not in production. Samples may or may not be available.

OBSOLETE: TI has discontinued the production of the device.

(2) **RoHS:** TI defines "RoHS" to mean semiconductor products that are compliant with the current EU RoHS requirements for all 10 RoHS substances, including the requirement that RoHS substance do not exceed 0.1% by weight in homogeneous materials. Where designed to be soldered at high temperatures, "RoHS" products are suitable for use in specified lead-free processes. TI may reference these types of products as "Pb-Free".

RoHS Exempt: TI defines "RoHS Exempt" to mean products that contain lead but are compliant with EU RoHS pursuant to a specific EU RoHS exemption.

Green: TI defines "Green" to mean the content of Chlorine (Cl) and Bromine (Br) based flame retardants meet JS709B low halogen requirements of <=1000ppm threshold. Antimony trioxide based flame retardants must also meet the <=1000ppm threshold requirement.

(3) MSL, Peak Temp. - The Moisture Sensitivity Level rating according to the JEDEC industry standard classifications, and peak solder temperature.

(4) There may be additional marking, which relates to the logo, the lot trace code information, or the environmental category on the device.

(5) Multiple Device Markings will be inside parentheses. Only one Device Marking contained in parentheses and separated by a "~" will appear on a device. If a line is indented then it is a continuation of the previous line and the two combined represent the entire Device Marking for that device.

⁽⁶⁾ Lead/Ball Finish - Orderable Devices may have multiple material finish options. Finish options are separated by a vertical ruled line. Lead/Ball Finish values may wrap to two lines if the finish value exceeds the maximum column width.

Important Information and Disclaimer:The information provided on this page represents TI's knowledge and belief as of the date that it is provided. TI bases its knowledge and belief on information provided by third parties, and makes no representation or warranty as to the accuracy of such information. Efforts are underway to better integrate information from third parties. TI has taken and continues to take reasonable steps to provide representative and accurate information but may not have conducted destructive testing or chemical analysis on incoming materials and chemicals. TI and TI suppliers consider certain information to be proprietary, and thus CAS numbers and other limited information may not be available for release.

In no event shall TI's liability arising out of such information exceed the total purchase price of the TI part(s) at issue in this document sold by TI to Customer on an annual basis.

NDE0003B

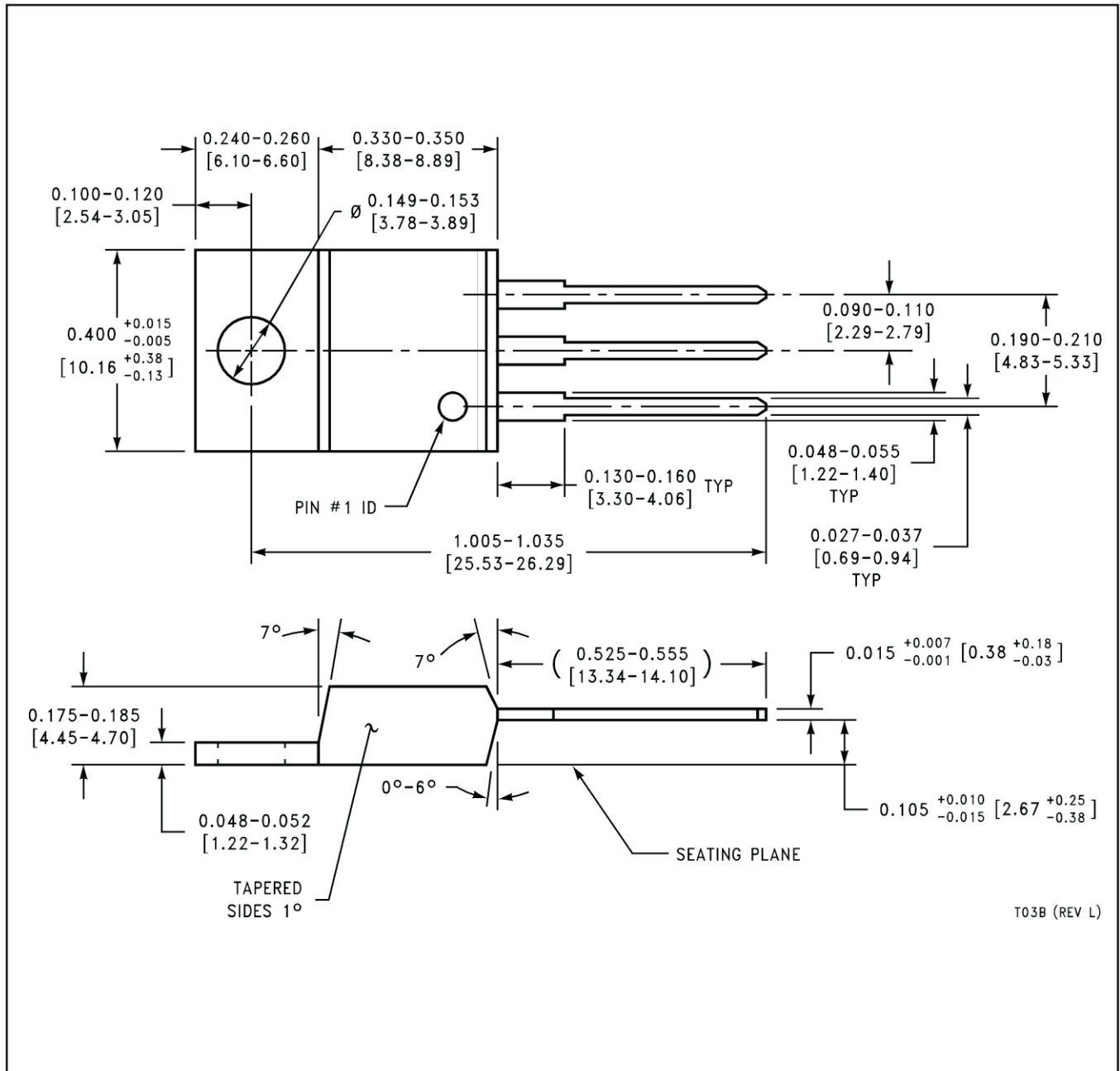

NDS0002A

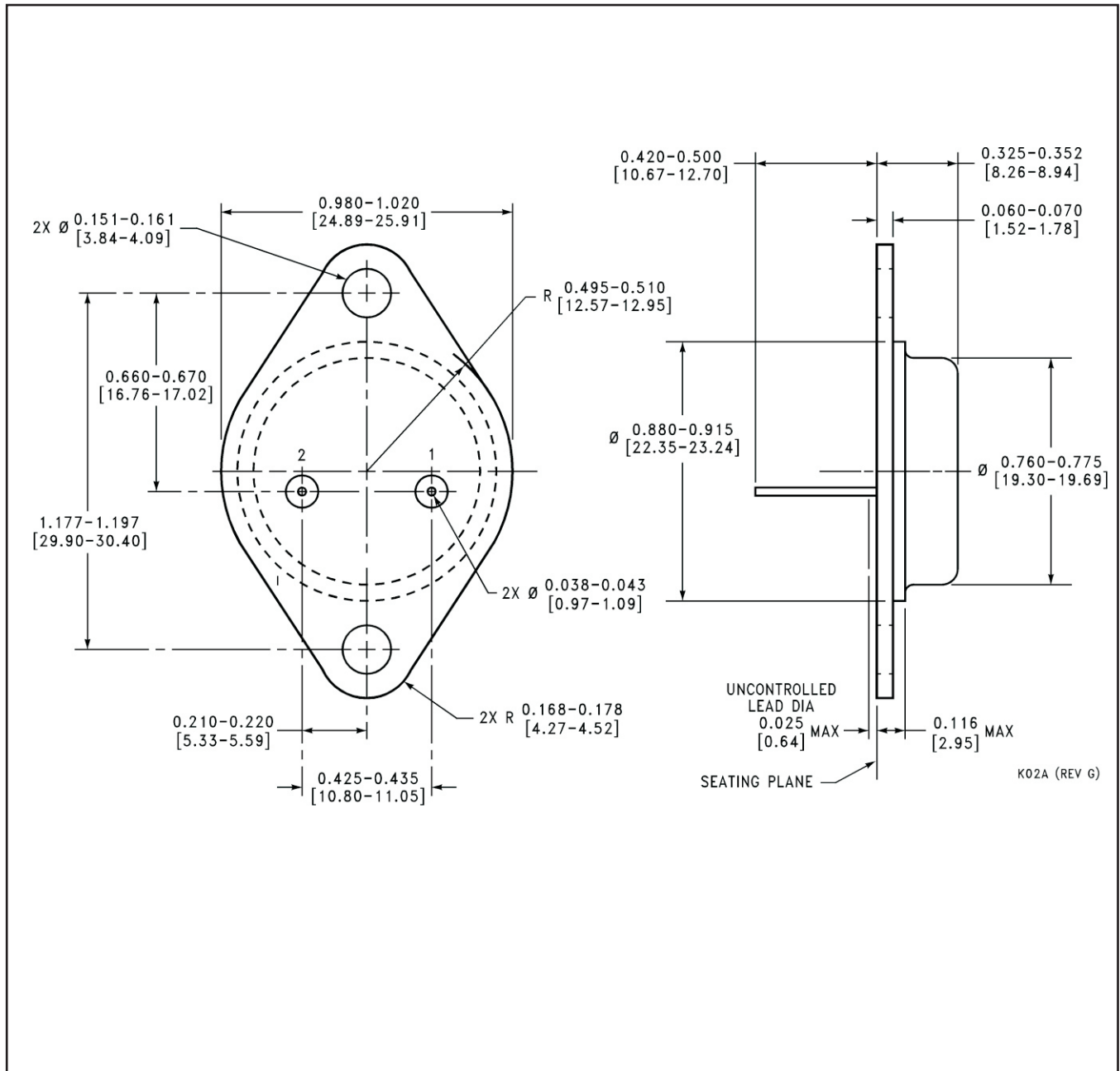

IMPORTANT NOTICE AND DISCLAIMER

TI PROVIDES TECHNICAL AND RELIABILITY DATA (INCLUDING DATASHEETS), DESIGN RESOURCES (INCLUDING REFERENCE DESIGNS), APPLICATION OR OTHER DESIGN ADVICE, WEB TOOLS, SAFETY INFORMATION, AND OTHER RESOURCES "AS IS" AND WITH ALL FAULTS, AND DISCLAIMS ALL WARRANTIES, EXPRESS AND IMPLIED, INCLUDING WITHOUT LIMITATION ANY IMPLIED WARRANTIES OF MERCHANTABILITY, FITNESS FOR A PARTICULAR PURPOSE OR NON-INFRINGEMENT OF THIRD PARTY INTELLECTUAL PROPERTY RIGHTS.

These resources are intended for skilled developers designing with TI products. You are solely responsible for (1) selecting the appropriate TI products for your application, (2) designing, validating and testing your application, and (3) ensuring your application meets applicable standards, and any other safety, security, or other requirements. These resources are subject to change without notice. TI grants you permission to use these resources only for development of an application that uses the TI products described in the resource. Other reproduction and display of these resources is prohibited. No license is granted to any other TI intellectual property right or to any third party intellectual property right. TI disclaims responsibility for, and you will fully indemnify TI and its representatives against, any claims, damages, costs, losses, and liabilities arising out of your use of these resources.

TI's products are provided subject to TI's Terms of Sale (www.ti.com/legal/termsofsale.html) or other applicable terms available either on ti.com or provided in conjunction with such TI products. TI's provision of these resources does not expand or otherwise alter TI's applicable warranties or warranty disclaimers for TI products.

Mailing Address: Texas Instruments, Post Office Box 655303, Dallas, Texas 75265
Copyright © 2018, Texas Instruments Incorporated

Looking for pricing, stock, or lifecycle information?

Click below to explore more details on WIN SOURCE:

 [View LM150K STEEL/NOPB on WIN SOURCE](#)

 [Texas Instruments](#) Information

Optimize Your Supply Chain with WIN SOURCE Solutions

-  Global Sourcing Solution
-  Obsolete Management
-  Cost Control Management
-  Shortage Management
-  Alternative Solution
-  Excess Inventory Management