



**THE DATASHEET OF
LM2574M-15/NOPB**



LM2574x SIMPLE SWITCHER® 0.5-A Step-Down Voltage Regulator

1 Features

- 3.3-V, 5-V, 12-V, 15-V, and Adjustable Output Versions
- Adjustable Version Output Voltage Range: 1.23 V to 37 V (57 V for HV version) $\pm 4\%$ Maximum Over Line and Load Conditions
- Specified 0.5-A Output Current
- Wide Input Voltage Range: 40 V, up to 60 V for HV Version
- Requires Only 4 External Components
- 52-kHz Fixed-Frequency Internal Oscillator
- TTL Shutdown Capability, Low-Power Standby Mode
- High Efficiency
- Uses Readily Available Standard Inductors
- Thermal Shutdown and Current-Limit Protection
- Create a Custom Design Using the LM2574 With the [WEBENCH® Power Designer](#)

2 Applications

- Simple High-Efficiency Step-Down (Buck) Regulator
- Efficient Preregulator for Linear Regulators
- On-Card Switching Regulators
- Positive-to-Negative Converter (Buck-Boost)

3 Description

The LM2574xx series of regulators are monolithic integrated circuits that provide all the active functions for a step-down (buck) switching regulator, capable of driving a 0.5-A load with excellent line and load regulation. These devices are available in fixed output voltages of 3.3 V, 5 V, 12 V, 15 V, and an adjustable output version.

Requiring a minimum number of external components, these regulators are simple to use and include internal frequency compensation and a fixed-frequency oscillator.

The LM2574xx series offers a high-efficiency replacement for popular three-terminal linear regulators. Because of its high efficiency, the copper traces on the printed-circuit board (PCB) are normally the only heat sinking needed.

A standard series of inductors optimized for use with the LM2574 are available from several different manufacturers. This feature greatly simplifies the design of switch-mode power supplies.

Other features include a specified $\pm 4\%$ tolerance on output voltage within specified input voltages and output load conditions, and $\pm 10\%$ on the oscillator frequency. External shutdown is included, featuring 50- μ A (typical) standby current. The output switch includes cycle-by-cycle current limiting, as well as thermal shutdown for full protection under fault conditions.

Device Information⁽¹⁾

PART NUMBER	PACKAGE	BODY SIZE (NOM)
LM2574, LM2574HV	SOIC (14)	8.992 mm \times 7.498 mm
	PDIP (8)	6.35 mm \times 9.81 mm

(1) For all available packages, see the orderable addendum at the end of the data sheet.

Typical Application (Fixed Output Voltage Versions)

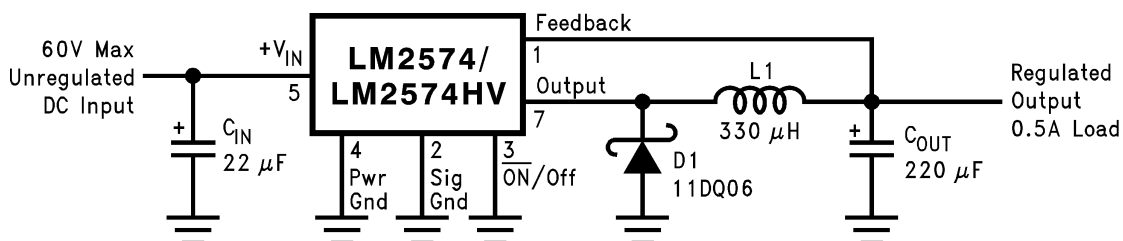

Copyright © 2016, Texas Instruments Incorporated



Table of Contents

1 Features	1	7.3 Feature Description	11
2 Applications	1	7.4 Device Functional Modes	13
3 Description	1	8 Application and Implementation	14
4 Revision History	2	8.1 Application Information	14
5 Pin Configuration and Functions	3	8.2 Typical Applications	19
6 Specifications	4	9 Power Supply Recommendations	26
6.1 Absolute Maximum Ratings	4	10 Layout	26
6.2 ESD Ratings	4	10.1 Layout Guidelines	26
6.3 Recommended Operating Conditions	4	10.2 Layout Example	27
6.4 Thermal Information	4	10.3 Grounding	27
6.5 Electrical Characteristics for All Output Voltage Versions	5	10.4 Thermal Considerations	27
6.6 Electrical Characteristics – 3.3-V Version	5	11 Device and Documentation Support	29
6.7 Electrical Characteristics – 5-V Version	6	11.1 Device Support	29
6.8 Electrical Characteristics – 12-V Version	6	11.2 Documentation Support	31
6.9 Electrical Characteristics – 15-V Version	6	11.3 Receiving Notification of Documentation Updates	31
6.10 Electrical Characteristics – Adjustable Version	7	11.4 Community Resources	31
6.11 Typical Characteristics	8	11.5 Trademarks	31
7 Detailed Description	11	11.6 Electrostatic Discharge Caution	31
7.1 Overview	11	11.7 Glossary	31
7.2 Functional Block Diagram	11	12 Mechanical, Packaging, and Orderable Information	31

4 Revision History

Changes from Revision D (April 2016) to Revision E	Page
• Added links for WEBENCH	1
• maximum supply voltage in <i>Abs Max Ratings</i> from "4.5" to "45" to correct typo	4

Changes from Revision C (April 2013) to Revision D	Page
• Added <i>Device Information</i> table, <i>ESD Ratings</i> table, <i>Feature Description</i> section, <i>Device Functional Modes</i> , <i>Application and Implementation</i> section, <i>Power Supply Recommendations</i> section, <i>Layout</i> section, <i>Device and Documentation Support</i> section, and <i>Mechanical, Packaging, and Orderable Information</i> section	1
• Changed $R_{\theta JA}$ value in SOIC column to 77.1	4
• Split test conditions row of the <i>Electrical Characteristics</i> table to include $T_J = 25^\circ\text{C}$ and $T_J < 25^\circ\text{C}$ MIN, TYP, and MAX values	5
• Split test conditions in I_L row to rearrange the MIN, TYP, and MAX values	5

Changes from Revision B (November 2004) to Revision C	Page
• Changed layout of National Data Sheet to TI format	1

5 Pin Configuration and Functions

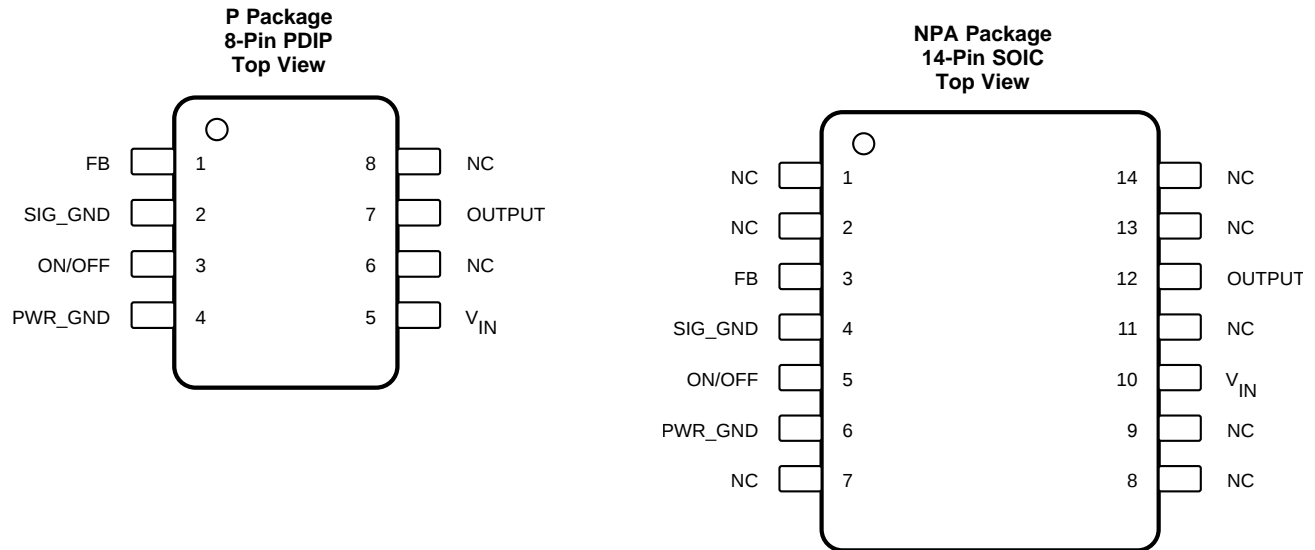

Pin Functions

NAME	PIN		I/O	DESCRIPTION
	PDIP	SOIC		
FB	1	3	I	Feedback sense input pin. Connect to the midpoint of feedback divider to set V _{OUT} for ADJ version or connect this pin directly to the output capacitor for a fixed output version.
NC	8, 6	1, 2, 7, 8, 9, 11, 13, 14	—	No internal connection, but must be soldered to PCB for best heat transfer.
ON/OFF	3	5	I	Enable input to the voltage regulator. High = OFF and low = ON. Connect to GND to enable the voltage regulator. Do not leave this pin float.
OUTPUT	7	12	O	Emitter pin of the power transistor. This is a switching node. Attached this pin to an inductor and the cathode of the external diode.
PWR_GND	4	6	—	Power ground pins. Connect to system ground and SIF GND, ground pins of C _{IN} and C _{OUT} . Path to C _{IN} must be as short as possible.
SIG_GND	2	4	—	Signal ground pin. Ground reference for internal references and logic. Connect to system ground.
V _{IN}	5	10	I	Supply input pin to collector pin of high-side transistor. Connect to power supply and input bypass capacitors C _{IN} . Path from V _{IN} pin to high frequency bypass C _{IN} and PWR GND must be as short as possible.

6 Specifications

6.1 Absolute Maximum Ratings

over operating free-air temperature range (unless otherwise noted)⁽¹⁾

		MIN	MAX	UNIT
Maximum supply voltage	LM2574		45	V
	LM2574HV		63	
$\overline{\text{ON}}/\text{OFF}$ pin input voltage		-0.3	V_{IN}	V
Output voltage to ground, steady-state			-1	V
Power dissipation		Internally limited		
Lead temperature, soldering (10 s)			260	°C
Maximum junction temperature			150	°C
Storage temperature, T_{stg}		-65	150	°C

- (1) Stresses beyond those listed under *Absolute Maximum Ratings* may cause permanent damage to the device. These are stress ratings only, which do not imply functional operation of the device at these or any other conditions beyond those indicated under *Recommended Operating Conditions*. Exposure to absolute-maximum-rated conditions for extended periods may affect device reliability.

6.2 ESD Ratings

			VALUE	UNIT
V_{ESD}	Electrostatic discharge	Human-body model (HBM), per ANSI/ESDA/JEDEC JS-001 ⁽¹⁾	±2000	V

- (1) JEDEC document JEP155 states that 500-V HBM allows safe manufacturing with a standard ESD control process.

6.3 Recommended Operating Conditions

over operating free-air temperature range (unless otherwise noted)

		MIN	NOM	MAX	UNIT
Supply voltage	LM2574		40		V
	LM2574HV		60		
T_{J}	Temperature	-40		125	°C

6.4 Thermal Information

THERMAL METRIC ⁽¹⁾⁽²⁾		LM2574, LM2574HV		UNIT
		P (PDIP)	NPA (SOIC)	
		8 PINS	14 PINS	
$R_{\theta\text{JA}}$	Junction-to-ambient thermal resistance ⁽³⁾	60.4	77.1	°C/W
$R_{\theta\text{JC(top)}}$	Junction-to-case (top) thermal resistance ⁽³⁾	59.9	29.2	°C/W
$R_{\theta\text{JB}}$	Junction-to-board thermal resistance ⁽³⁾	37.9	33.3	°C/W
Ψ_{JT}	Junction-to-top characterization parameter	17.1	2	°C/W
Ψ_{JB}	Junction-to-board characterization parameter	37.7	32.8	°C/W
$R_{\theta\text{JC(bot)}}$	Junction-to-case (bottom) thermal resistance ⁽³⁾	—	—	°C/W

- (1) For more information about traditional and new thermal metrics, see the [Semiconductor and IC Package Thermal Metrics application report](#).
 (2) The package thermal impedance is calculated in accordance with JESD 51-7.
 (3) Thermal resistances were simulated on a 4-layer, JEDEC board.

6.5 Electrical Characteristics for All Output Voltage Versions

$T_J = 25^\circ\text{C}$, and MIN and MAX apply over full operating temperature range. $V_{IN} = 12\text{ V}$ for the 3.3-V, 5-V, and adjustable version, $V_{IN} = 25\text{ V}$ for the 12-V version, and $V_{IN} = 30\text{ V}$ for the 15-V version, $I_{LOAD} = 100\text{ mA}$ (unless otherwise noted).

PARAMETER		TEST CONDITIONS		MIN ⁽¹⁾	TYP	MAX ⁽¹⁾	UNIT
I_b	Feedback bias current	Adjustable version only, $V_{OUT} = 5\text{ V}$	$T_J = 25^\circ\text{C}$		50	100	nA
			$-40^\circ\text{C} < T_J < 125^\circ\text{C}$			500	
f_O	Oscillator frequency	See ⁽²⁾	$T_J = 25^\circ\text{C}$	47	52	58	kHz
			$-40^\circ\text{C} < T_J < 125^\circ\text{C}$	42		63	
V_{SAT}	Saturation voltage	$I_{OUT} = 0.5\text{ A}$ ⁽³⁾	$T_J = 25^\circ\text{C}$		0.9	1.2	V
			$-40^\circ\text{C} < T_J < 125^\circ\text{C}$			1.4	
DC	Maximum duty cycle (ON)	See ⁽⁴⁾		93%	98%		
I_{CL}	Current limit	Peak current ⁽²⁾⁽³⁾		0.7	1	1.6	A
				0.65		1.8	
I_L	Current output leakage	Output = 0 V				2	mA
		Output = -1 V ⁽⁵⁾⁽⁶⁾			7.5	30	
I_Q	Quiescent current	See ⁽⁵⁾			5	10	mA
I_{STBY}	Standby quiescent current	$\overline{\text{ON}}/\text{OFF}$ pin = 5 V (OFF)			50	200	μA
$\overline{\text{ON}}/\text{OFF}$ CONTROL (SEE Figure 27)							
V_{IH}	$\overline{\text{ON}}/\text{OFF}$ pin logic input level	$V_{OUT} = 0\text{ V}$	$T_J = 25^\circ\text{C}$	2.2	1.4		V
			$-40^\circ\text{C} < T_J < 125^\circ\text{C}$	2.4			
V_{IL}	$\overline{\text{ON}}/\text{OFF}$ pin logic input level	$V_{OUT} = \text{Nominal output voltage}$	$T_J = 25^\circ\text{C}$		1.2	1	V
			$-40^\circ\text{C} < T_J < 125^\circ\text{C}$			0.8	
I_H	$\overline{\text{ON}}/\text{OFF}$ pin input current	$\overline{\text{ON}}/\text{OFF}$ pin = 5 V (OFF)			12	30	μA
I_{IL}		$\overline{\text{ON}}/\text{OFF}$ pin = 0 V (ON)			0	10	μA

- (1) All limits specified at room temperature TYP and MAX. All room temperature limits are 100% production tested. All limits at temperature extremes are specified through correlation using standard Statistical Quality Control (SQC) methods. All limits are used to calculate Average Outgoing Quality Level.
- (2) The oscillator frequency reduces to approximately 18 kHz in the event of an output short or an overload which causes the regulated output voltage to drop approximately 40% from the nominal output voltage. This self protection feature lowers the average power dissipation of the IC by lowering the minimum duty cycle from 5% down to approximately 2% (see Figure 6).
- (3) Output pin sourcing current. No diode, inductor or capacitor connected to output pin.
- (4) Feedback pin removed from output and connected to 0 V.
- (5) Feedback pin removed from output and connected to 12 V for the adjustable, 3.3-V, and 5-V versions, and 25 V for the 12-V and 15-V versions, to force the output transistor OFF.
- (6) $V_{IN} = 40\text{ V}$ (60 V for high voltage version).

6.6 Electrical Characteristics – 3.3-V Version

$T_J = 25^\circ\text{C}$, and all MIN and MAX apply over full operating temperature range (unless otherwise noted).

PARAMETER ⁽¹⁾	TEST CONDITIONS		MIN ⁽²⁾	TYP	MAX ⁽²⁾	UNIT	
V_{OUT}	Output voltage	$V_{IN} = 12\text{ V}$, $I_{LOAD} = 100\text{ mA}$		3.234	3.3	3.366	V
		LM2574, $4.75\text{ V} \leq V_{IN} \leq 40\text{ V}$, $0.1\text{ A} \leq I_{LOAD} \leq 0.5\text{ A}$	$T_J = 25^\circ\text{C}$	3.168	3.3	3.432	
			$-40^\circ\text{C} \leq T_J \leq 125^\circ\text{C}$	3.135		3.465	
		LM2574HV, $4.75\text{ V} \leq V_{IN} \leq 60\text{ V}$, $0.1\text{ A} \leq I_{LOAD} \leq 0.5\text{ A}$	$T_J = 25^\circ\text{C}$	3.168	3.3	3.45	
$-40^\circ\text{C} \leq T_J \leq 125^\circ\text{C}$	3.135			3.482			
η	Efficiency	$V_{IN} = 12\text{ V}$, $I_{LOAD} = 0.5\text{ A}$		72%			

- (1) Test Circuit in Figure 22 and Figure 27.
- (2) All limits specified at room temperature and at temperature extremes. All room temperature limits are 100% production tested. All limits at temperature extremes are specified via correlation using standard Statistical Quality Control (SQC) methods. All limits are used to calculate Average Outgoing Quality Level.

6.7 Electrical Characteristics – 5-V Version

$T_J = 25^\circ\text{C}$, and all MIN and MAX apply over full operating temperature range (unless otherwise noted).

PARAMETER ⁽¹⁾	TEST CONDITIONS	MIN	TYP ⁽²⁾	MAX ⁽²⁾	UNIT	
V_{OUT} Output voltage	$V_{IN} = 12\text{ V}$, $I_{LOAD} = 100\text{ mA}$	4.9	5	5.1	V	
	LM2574, $7\text{ V} \leq V_{IN} \leq 40\text{ V}$, $0.1\text{ A} \leq I_{LOAD} \leq 0.5\text{ A}$	$T_J = 25^\circ\text{C}$	4.8	5		5.2
		$-40^\circ\text{C} \leq T_J \leq 125^\circ\text{C}$	4.75			5.25
	LM2574HV, $7\text{ V} \leq V_{IN} \leq 60\text{ V}$, $0.1\text{ A} \leq I_{LOAD} \leq 0.5\text{ A}$	$T_J = 25^\circ\text{C}$	4.8	5		5.225
$-40^\circ\text{C} \leq T_J \leq 125^\circ\text{C}$		4.75		5.275		
η Efficiency	$V_{IN} = 12\text{ V}$, $I_{LOAD} = 0.5\text{ A}$	77%				

(1) Test circuit in [Figure 22](#) and [Figure 27](#).

(2) All limits specified at room temperature TYP and MAX. All room temperature limits are 100% production tested. All limits at temperature extremes are specified through correlation using standard Statistical Quality Control (SQC) methods. All limits are used to calculate Average Outgoing Quality Level.

6.8 Electrical Characteristics – 12-V Version

$T_J = 25^\circ\text{C}$, and all MIN and MAX apply over full operating temperature range (unless otherwise noted).

PARAMETER ⁽¹⁾	CONDITIONS	MIN	TYP ⁽²⁾	MAX ⁽²⁾	UNIT	
V_{OUT} Output voltage	$V_{IN} = 25\text{ V}$, $I_{LOAD} = 100\text{ mA}$	11.76	12	12.24	V	
	LM2574, $15\text{ V} \leq V_{IN} \leq 40\text{ V}$, $0.1\text{ A} \leq I_{LOAD} \leq 0.5\text{ A}$	$T_J = 25^\circ\text{C}$	11.52	12		12.48
		$-40^\circ\text{C} \leq T_J \leq 125^\circ\text{C}$	11.4			12.6
	LM2574HV, $15\text{ V} \leq V_{IN} \leq 60\text{ V}$, $0.1\text{ A} \leq I_{LOAD} \leq 0.5\text{ A}$	$T_J = 25^\circ\text{C}$	11.52	12		12.54
$-40^\circ\text{C} \leq T_J \leq 125^\circ\text{C}$		11.4		12.66		
η Efficiency	$V_{IN} = 15\text{ V}$, $I_{LOAD} = 0.5\text{ A}$	88%				

(1) Test circuit in [Figure 22](#) and [Figure 27](#).

(2) All limits specified at room temperature TYP and MAX. All room temperature limits are 100% production tested. All limits at temperature extremes are specified through correlation using standard Statistical Quality Control (SQC) methods. All limits are used to calculate Average Outgoing Quality Level.

6.9 Electrical Characteristics – 15-V Version

$T_J = 25^\circ\text{C}$, and all MIN and MAX apply over full operating temperature range (unless otherwise noted).

PARAMETER ⁽¹⁾	TEST CONDITIONS	MIN	TYP ⁽²⁾	MAX ⁽²⁾	UNIT	
V_{OUT} Output voltage	$V_{IN} = 30\text{ V}$, $I_{LOAD} = 100\text{ mA}$	14.7	15	15.3	V	
	LM2574, $18\text{ V} \leq V_{IN} \leq 40\text{ V}$, $0.1\text{ A} \leq I_{LOAD} \leq 0.5\text{ A}$	$T_J = 25^\circ\text{C}$	14.4	15		15.6
		$-40^\circ\text{C} \leq T_J \leq 125^\circ\text{C}$	14.25			15.75
	LM2574HV, $18\text{ V} \leq V_{IN} \leq 60\text{ V}$, $0.1\text{ A} \leq I_{LOAD} \leq 0.5\text{ A}$	$T_J = 25^\circ\text{C}$	14.4	15		15.68
$-40^\circ\text{C} \leq T_J \leq 125^\circ\text{C}$		14.25		15.83		
η Efficiency	$V_{IN} = 18\text{ V}$, $I_{LOAD} = 0.5\text{ A}$	88%				

(1) Test circuit in [Figure 22](#) and [Figure 27](#).

(2) All limits specified at room temperature TYP and MAX. All room temperature limits are 100% production tested. All limits at temperature extremes are specified through correlation using standard Statistical Quality Control (SQC) methods. All limits are used to calculate Average Outgoing Quality Level.

6.10 Electrical Characteristics – Adjustable Version

$T_J = 25^\circ\text{C}$, and all MIN and MAX apply over full operating temperature range. $V_{IN} = 12\text{ V}$, $I_{LOAD} = 100\text{ mA}$ (unless otherwise noted).

PARAMETER ⁽¹⁾	TEST CONDITIONS	MIN	TYP ⁽²⁾	MAX ⁽²⁾	UNIT	
V_{FB} Feedback voltage	$V_{IN} = 12\text{ V}$, $I_{LOAD} = 100\text{ mA}$	1.217	1.23	1.243	V	
	LM2574, $7\text{ V} \leq V_{IN} \leq 40\text{ V}$, $0.1\text{ A} \leq I_{LOAD} \leq 0.5\text{ A}$, V_{OUT} programmed for 5 V	$T_J = 25^\circ\text{C}$	1.193	1.23		1.267
		$-40^\circ\text{C} \leq T_J \leq 125^\circ\text{C}$	1.18			1.28
	LM2574HV, $7\text{ V} \leq V_{IN} \leq 60\text{ V}$, $0.1\text{ A} \leq I_{LOAD} \leq 0.5\text{ A}$, V_{OUT} programmed for 5 V	$T_J = 25^\circ\text{C}$	1.193	1.23		1.273
$-40^\circ\text{C} \leq T_J \leq 125^\circ\text{C}$		1.18		1.286		
η Efficiency	$V_{IN} = 12\text{ V}$, $V_{OUT} = 5\text{ V}$, $I_{LOAD} = 0.5\text{ A}$		77%			

(1) Test circuit in [Figure 22](#) and [Figure 27](#).

(2) All limits specified at room temperature TYP and MAX. All room temperature limits are 100% production tested. All limits at temperature extremes are specified through correlation using standard Statistical Quality Control (SQC) methods. All limits are used to calculate Average Outgoing Quality Level.

6.11 Typical Characteristics

See Figure 27.

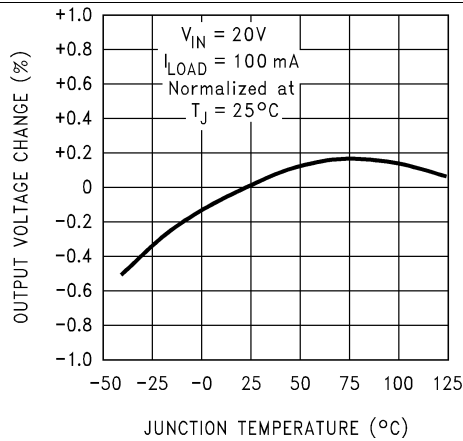

Figure 1. Normalized Output Voltage

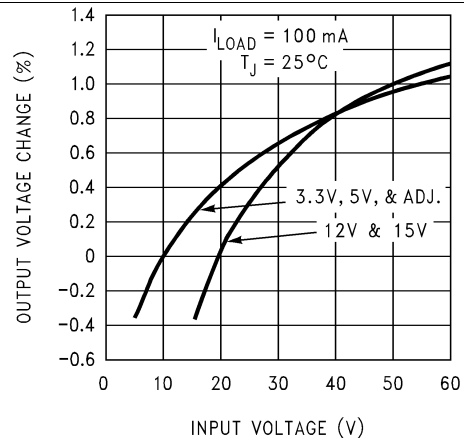

Figure 2. Line Regulation

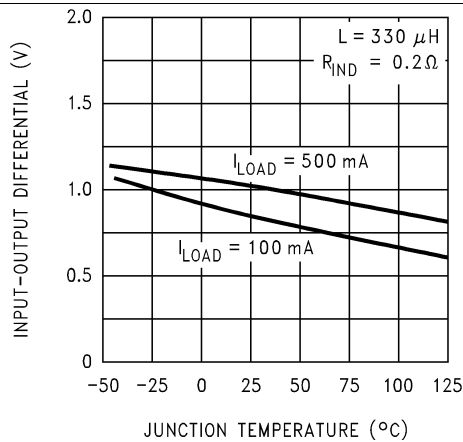

Figure 3. Dropout Voltage

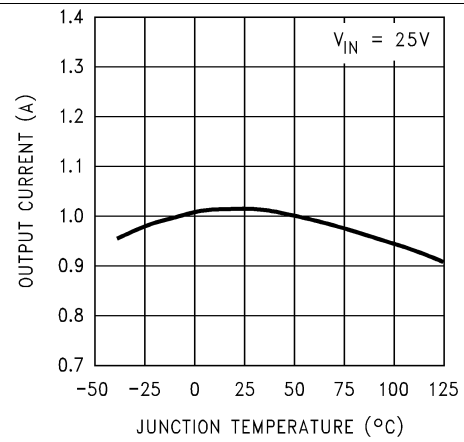

Figure 4. Current Limit

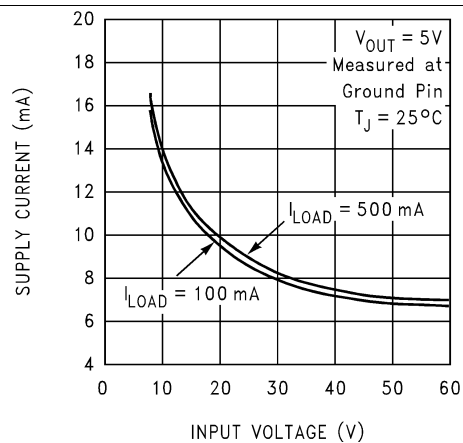

Figure 5. Supply Current

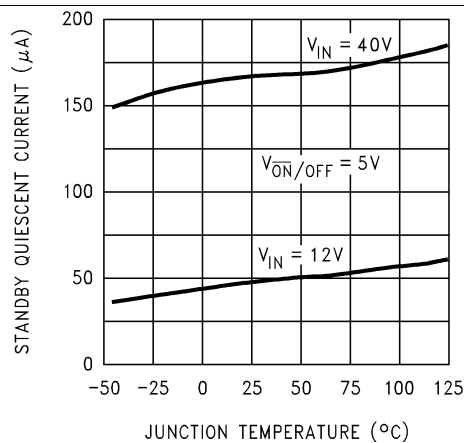

Figure 6. Standby Quiescent Current

Typical Characteristics (continued)

See Figure 27.

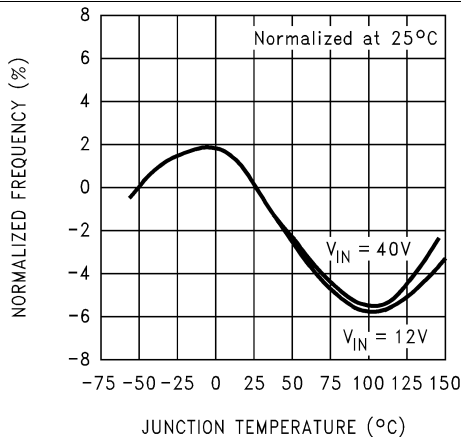

Figure 7. Oscillator Frequency

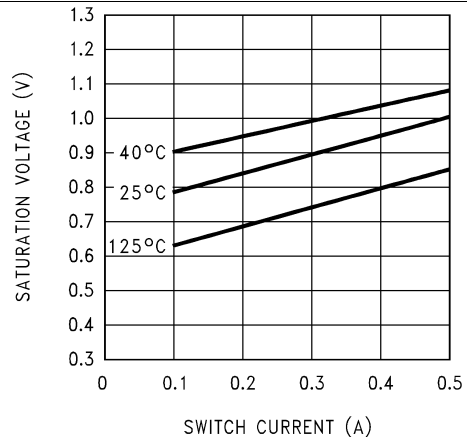

Figure 8. Switch Saturation Voltage

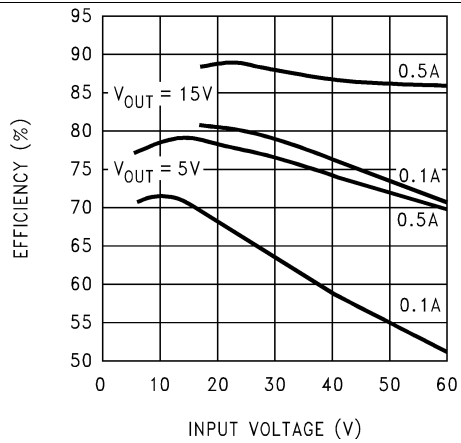

Figure 9. Efficiency

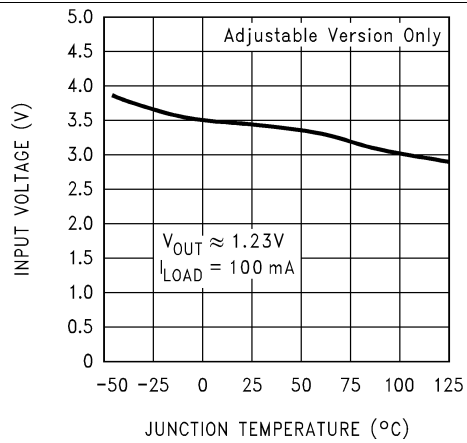

Figure 10. Minimum Operating Voltage

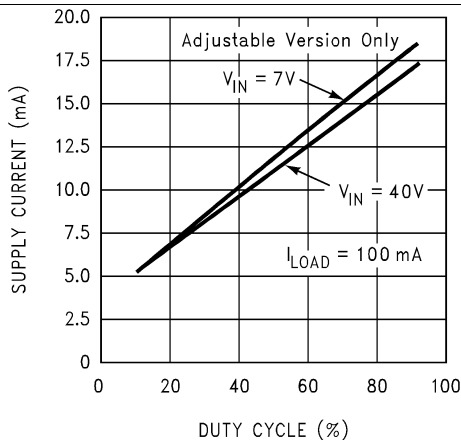

Figure 11. Supply Current vs Duty Cycle

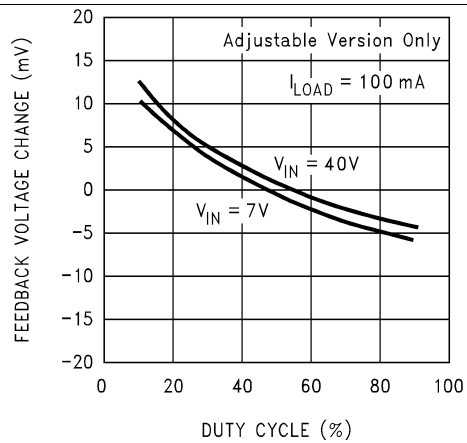
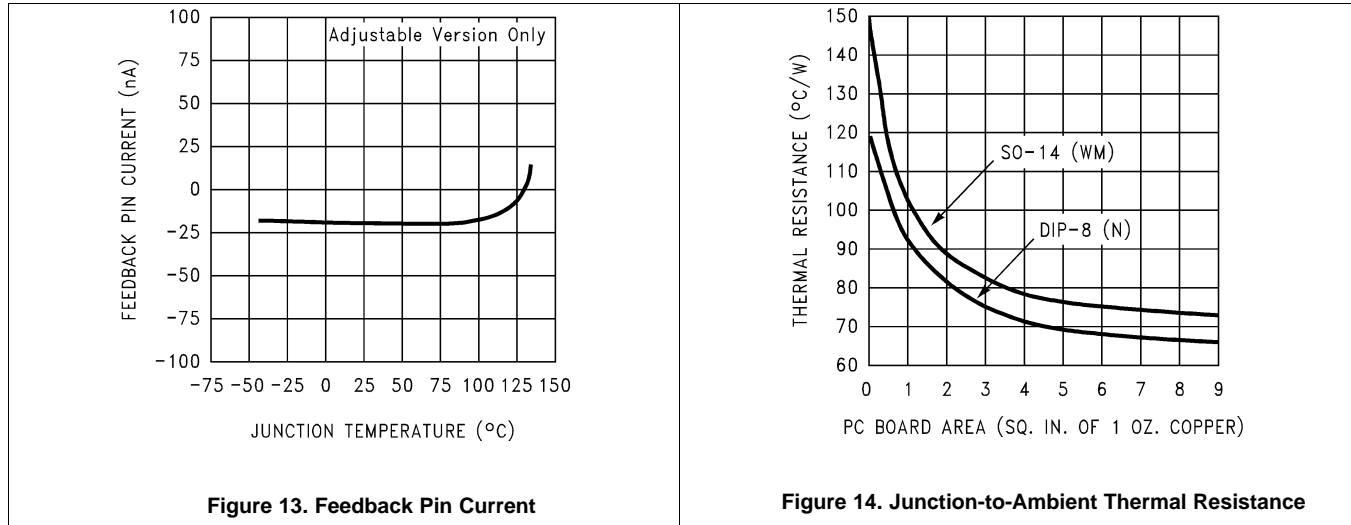

Figure 12. Feedback Voltage vs Duty Cycle

Typical Characteristics (continued)

See [Figure 27](#).



7 Detailed Description

7.1 Overview

The LM2574 SIMPLE SWITCHER[®] regulator is an easy-to-use, non-synchronous, step-down DC-DC converter with a wide input voltage range from 40 V to up to 60 V for a HV version. It is capable of delivering up to 0.5-A DC load current with excellent line and load regulation. These devices are available in fixed output voltages of 3.3 V, 5 V, 12 V, 15 V, and an adjustable output version. The family requires few external components and the pin arrangement was designed for simple, optimum PCB layout.

7.2 Functional Block Diagram

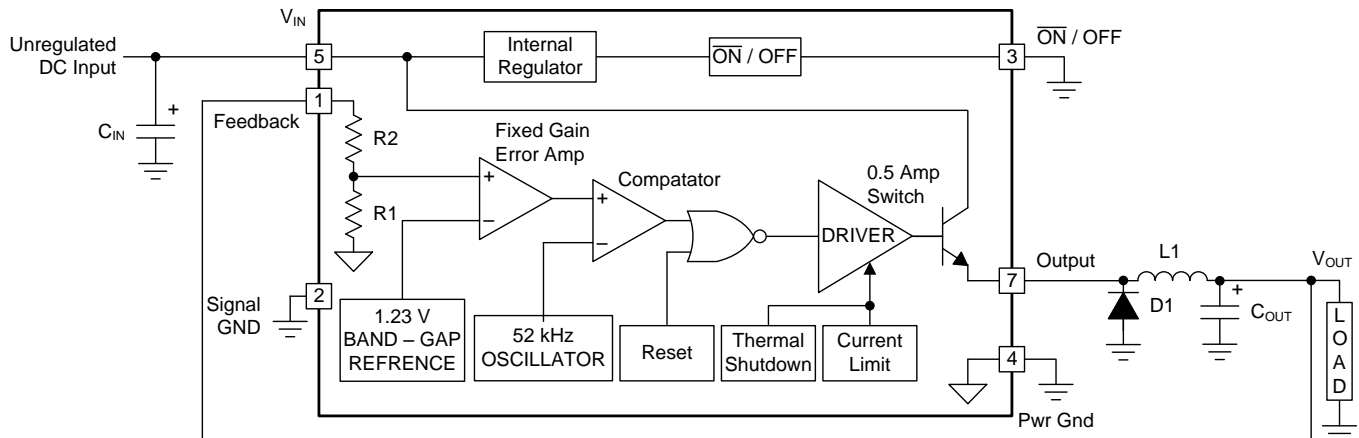

Copyright © 2016, Texas Instruments Incorporated

Note: Pin numbers are for the 8-pin PDIP package

R1 = 1 k

3.3 V, R2 = 1.7 k

5 V, R2 = 3.1 k

12 V, R2 = 8.84 k

15 V, R2 = 11.3 k

For adjustable version,

R1 = Open, R2 = 0 Ω

7.3 Feature Description

7.3.1 Current Limit

The LM2574 device has current limiting to prevent the switch current from exceeding safe values during an accidental overload on the output. This value (I_{CL}) can be found in [Electrical Characteristics for All Output Voltage Versions](#).

7.3.2 Undervoltage Lockout

In some applications, it is desirable to keep the regulator off until the input voltage reaches a certain threshold. An undervoltage lockout circuit which accomplishes this task is shown in [Figure 15](#) while [Figure 16](#) shows the same circuit applied to a buck-boost configuration. These circuits keep the regulator off until the input voltage reaches a predetermined level in [Equation 1](#).

$$V_{TH} \approx V_{Z1} + 2 V_{BE} \quad (1)$$

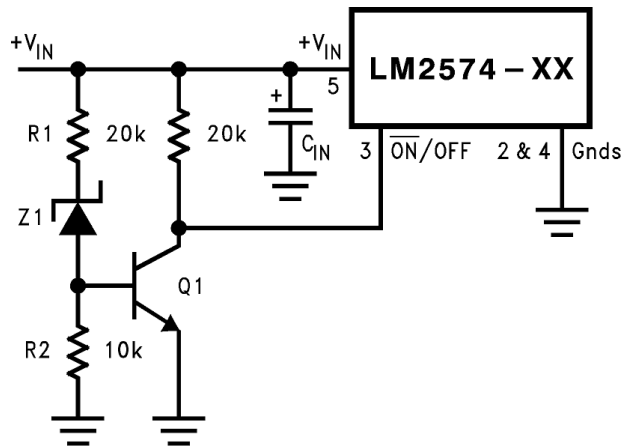
Feature Description (continued)

Note: Complete circuit not shown (see [Figure 20](#)).

Note: Pin numbers are for 8-pin PDIP package.

Figure 15. Undervoltage Lockout for Buck Circuit

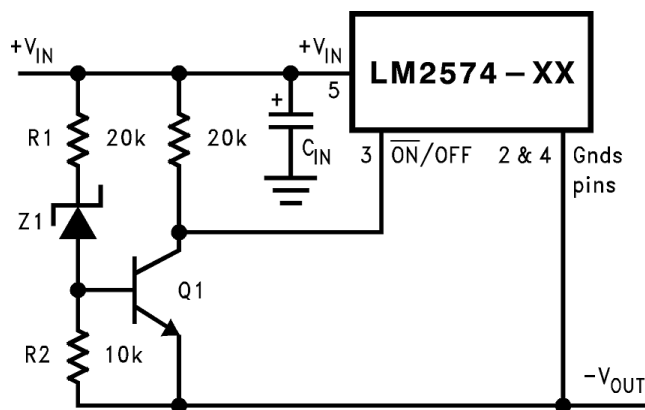

Note: Complete circuit not shown (see [Figure 20](#)).

Note: Pin numbers are for 8-pin PDIP package.

Figure 16. Undervoltage Lockout for Buck-Boost Circuit

7.3.3 Delayed Start-Up

The $\overline{\text{ON/OFF}}$ pin can be used to provide a delayed start-up feature as shown in [Figure 17](#). With an input voltage of 20 V and for the part values shown, the circuit provides approximately 10 ms of delay time before the circuit begins switching. Increasing the RC time constant can provide longer delay times. But excessively large RC time constants can cause problems with input voltages that are high in 60-Hz or 120-Hz ripple, by coupling the ripple into the ON/OFF pin.

7.3.4 Adjustable Output, Low-Ripple Power Supply

A 500-mA power supply that features an adjustable output voltage is shown in [Figure 18](#). An additional L-C filter that reduces the output ripple by a factor of 10 or more is included in this circuit.

Feature Description (continued)

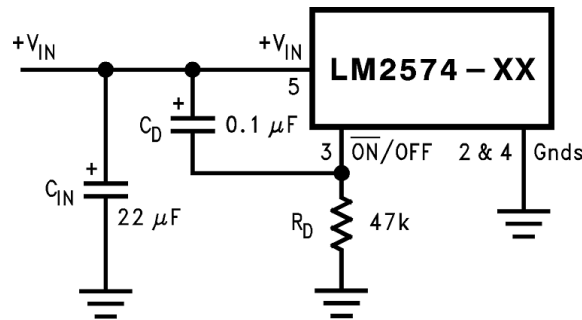

Note: Complete circuit not shown.
Note: Pin numbers are for 8-pin PDIP package.

Figure 17. Delayed Start-Up

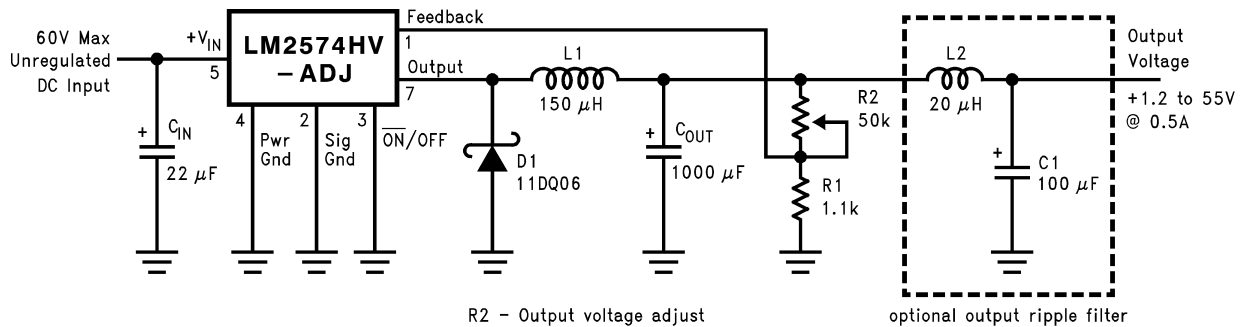

Note: Pin numbers are for 8-pin PDIP package.

Figure 18. 1.2-V to 55-V Adjustable 500-mA Power Supply With Low-Output Ripple

7.4 Device Functional Modes

7.4.1 Shutdown Mode

The $\overline{\text{ON/OFF}}$ pin provides electrical ON and OFF control for the LM2574. When the voltage of this pin is higher than 1.4 V, the device is shutdown mode. The typical standby current in this mode is 50 μA .

7.4.2 Active Mode

When the voltage of the ON/OFF pin is below 1.2 V, the device starts switching and the output voltage rises until it reaches a normal regulation voltage.

8 Application and Implementation

NOTE

Information in the following applications sections is not part of the TI component specification, and TI does not warrant its accuracy or completeness. TI's customers are responsible for determining suitability of components for their purposes. Customers should validate and test their design implementation to confirm system functionality.

8.1 Application Information

8.1.1 Input Capacitor (C_{IN})

To maintain stability, the regulator input pin must be bypassed with at least a 22- μ F electrolytic capacitor. The leads of the capacitor must be kept short, and located near the regulator.

If the operating temperature range includes temperatures below -25°C , the input capacitor value may need to be larger. With most electrolytic capacitors, the capacitance value decreases and the ESR increases with lower temperatures and age. Paralleling a ceramic or solid tantalum capacitor increases the regulator stability at cold temperatures. For maximum capacitor operating lifetime, the RMS ripple current rating of the capacitor must be greater than [Equation 2](#).

$$1.2 \times \frac{t_{ON}}{T} \times I_{LOAD}$$

where

- $\frac{t_{ON}}{T} = \frac{V_{OUT}}{V_{IN}}$ for a buck regulator
 - $\frac{t_{ON}}{T} = \frac{|V_{OUT}|}{|V_{OUT}| + V_{IN}}$ for a buck-boost regulator
- (2)

8.1.2 Inductor Selection

All switching regulators have two basic modes of operation: continuous and discontinuous. The difference between the two types relates to the inductor current, whether it is flowing continuously, or if it drops to zero for a period of time in the normal switching cycle. Each mode has distinctively different operating characteristics, which can affect the regulator performance and requirements.

The LM2574 (or any of the SIMPLE SWITCHER family) can be used for both continuous and discontinuous modes of operation.

In many cases the preferred mode of operation is in the continuous mode. It offers better load regulation, lower peak switch, inductor, and diode currents, and can have lower output ripple voltage. But it does require relatively large inductor values to keep the inductor current flowing continuously, especially at low output load currents.

To simplify the inductor selection process, an inductor selection guide (nomograph) was designed. This guide assumes continuous mode operation, and selects an inductor that allows a peak-to-peak inductor ripple current (ΔI_{IND}) to be a certain percentage of the maximum design load current. In the LM2574 SIMPLE SWITCHER, the peak-to-peak inductor ripple current percentage (of load current) is allowed to change as different design load currents are selected. By allowing the percentage of inductor ripple current to increase for lower current applications, the inductor size and value can be kept relatively low.

8.1.3 Inductor Ripple Current

When the switcher is operating in the continuous mode, the inductor current waveform ranges from a triangular to a sawtooth type of waveform (depending on the input voltage). For a given input voltage and output voltage, the peak-to-peak amplitude of this inductor current waveform remains constant. As the load current rises or falls, the entire sawtooth current waveform also rises or falls. The average DC value of this waveform is equal to the DC load current (in the buck regulator configuration).

Application Information (continued)

If the load current drops to a low enough level, the bottom of the sawtooth current waveform reaches zero, and the switcher changes to a discontinuous mode of operation. This is a perfectly acceptable mode of operation. Any buck switching regulator (no matter how large the inductor value is) is forced to run discontinuous if the load current is light enough.

The curve shown in [Figure 19](#) illustrates how the peak-to-peak inductor ripple current (ΔI_{IND}) is allowed to change as different maximum load currents are selected, and also how it changes as the operating point varies from the upper border to the lower border within an inductance region (see [Inductor Selection](#)).

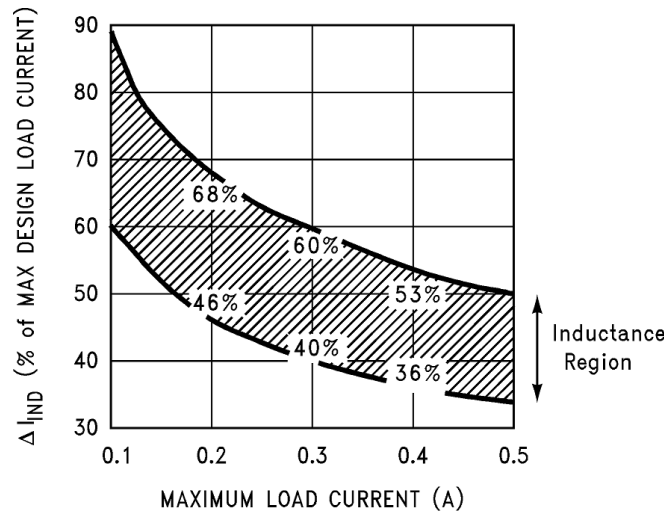

Figure 19. Inductor Ripple Current (ΔI_{IND}) Range

Consider the following example:

$$V_{OUT} = 5 \text{ V at } 0.4 \text{ A}$$

$$V_{IN} = 10\text{-V minimum up to } 20\text{-V maximum}$$

The selection guide in [Figure 24](#) shows that for a 0.4-A load current, and an input voltage range between 10 V and 20 V, the inductance region selected by the guide is 330 μH . This value of inductance allows a peak-to-peak inductor ripple current (ΔI_{IND}) to flow that is a percentage of the maximum load current. For this inductor value, the ΔI_{IND} also varies depending on the input voltage. As the input voltage increases to 20 V, it approaches the upper border of the inductance region, and the inductor ripple current increases. Referring to the curve in [Figure 19](#), it can be seen that at the 0.4-A load current level, and operating near the upper border of the 330- μH inductance region, the ΔI_{IND} is 53% of 0.4 A, or 212 mA_{p-p} .

This ΔI_{IND} is important because from this number the peak inductor current rating can be determined, the minimum load current required before the circuit goes to discontinuous operation, and also, knowing the ESR of the output capacitor, the output ripple voltage can be calculated, or conversely, measuring the output ripple voltage and knowing the ΔI_{IND} , the ESR can be calculated.

From the previous example, the peak-to-peak inductor ripple current (ΔI_{IND}) = 212 mA_{p-p} . When the ΔI_{IND} value is known, the following three formulas can be used to calculate additional information about the switching regulator circuit:

1. Peak inductor or peak switch current in [Equation 3](#).

$$= \left(I_{LOAD} + \frac{\Delta I_{IND}}{2} \right) = \left(0.4 \text{ A} + \frac{212}{2} \right) = 506 \text{ mA} \quad (3)$$

2. Minimum load current before the circuit becomes discontinuous in [Equation 4](#).

$$= \frac{\Delta I_{IND}}{2} = \frac{212}{2} = 106 \text{ mA} \quad (4)$$

3. Output ripple voltage = (ΔI_{IND}) \times (ESR of C_{OUT})

Application Information (continued)

The selection guide chooses inductor values suitable for continuous mode operation, but if the inductor value chosen is prohibitively high, the designer should investigate the possibility of discontinuous operation.

Inductors are available in different styles such as pot core, toroid, E-frame, bobbin core, and so forth, as well as different core materials, such as ferrites and powdered iron. The least expensive, the bobbin core type, consists of wire wrapped on a ferrite rod core. This type of construction makes for an inexpensive inductor, but because the magnetic flux is not completely contained within the core, it generates more electro-magnetic interference (EMI). This EMI can cause problems in sensitive circuits, or can give incorrect scope readings because of induced voltages in the scope probe.

The inductors listed in the selection chart include powdered iron toroid for Pulse Engineering, and ferrite bobbin core for Renco.

An inductor must not be operated beyond its maximum rated current because it may saturate. When an inductor begins to saturate, the inductance decreases rapidly and the inductor begins to look mainly resistive (the DC resistance of the winding). This can cause the inductor current to rise very rapidly and affects the energy storage capabilities of the inductor and could cause inductor overheating. Different inductor types have different saturation characteristics, and consider this when selecting an inductor. The inductor manufacturers' data sheets include current and energy limits to avoid inductor saturation.

8.1.4 Output Capacitor

An output capacitor is required to filter the output voltage and is needed for loop stability. The capacitor must be located near the LM2574 using short PCB traces. Standard aluminum electrolytics are usually adequate, but low ESR types are recommended for low output ripple voltage and good stability. The ESR of a capacitor depends on many factors, some which are: the value, the voltage rating, physical size, and the type of construction. In general, low-value or low-voltage (less than 12 V) electrolytic capacitors usually have higher ESR numbers.

The amount of output ripple voltage is primarily a function of the equivalent series resistance (ESR) of the output capacitor and the amplitude of the inductor ripple current, ΔI_{IND} (see [Inductor Ripple Current \(\$\Delta I_{IND}\$ \)](#)).

The lower capacitor values (100 μ F to 330 μ F) allows typically 50 mV to 150 mV of output ripple voltage, while larger-value capacitors reduce the ripple to approximately 20 mV to 50 mV (as seen in [Equation 5](#)).

$$\text{Output Ripple Voltage} = (\Delta I_{IND}) (\text{ESR of } C_{OUT}) \quad (5)$$

To further reduce the output ripple voltage, several standard electrolytic capacitors may be paralleled, or a higher-grade capacitor may be used. Such capacitors are often called high-frequency, low-inductance, or low-ESR. These reduce the output ripple to 10 mV or 20 mV. However, when operating in the continuous mode, reducing the ESR below 0.03 Ω can cause instability in the regulator.

Tantalum capacitors can have a very low ESR, and must be carefully evaluated if it is the only output capacitor. Because of their good low temperature characteristics, a tantalum can be used in parallel with aluminum electrolytics, with the tantalum making up 10% or 20% of the total capacitance.

The ripple current rating of the capacitor at 52 kHz must be at least 50% higher than the peak-to-peak inductor ripple current.

8.1.5 Catch Diode

Buck regulators require a diode to provide a return path for the inductor current when the switch is off. This diode must be located close to the LM2574 using short leads and short printed-circuit traces.

Because of their fast switching speed and low forward voltage drop, Schottky diodes provide the best efficiency, especially in low output voltage switching regulators (less than 5 V). fast-recovery, high-efficiency, or ultra-fast recovery diodes are also suitable, but some types with an abrupt turnoff characteristic may cause instability and EMI problems. A fast-recovery diode with soft recovery characteristics is a better choice. Standard 60-Hz diodes (for example, 1N4001 or 1N5400, and so forth) are also not suitable. See [Table 1](#) for Schottky and soft fast-recovery diode selection guide.

Table 1. Diode Selection Guide

V_R	1-A DIODES	
	SCHOTTKY	FAST RECOVERY
20 V	1N5817 SR102 MBR120P	The following diodes are all rated to 100 V 11DF1 10JF1 MUR110 HER102
30 V	1N5818 SR103 11DQ03 MBR130P 10JQ030	
40 V	1N5819 SR104 11DQ04 11JQ04 MBR140P	
50 V	MBR150 SR105 11DQ05 11JQ05	
60 V	MBR160 SR106 11DQ06 11JQ06	
90 V	11DQ09	

8.1.6 Output Voltage Ripple and Transients

The output voltage of a switching power supply contains a sawtooth ripple voltage at the switcher frequency, typically about 1% of the output voltage, and may also contain short voltage spikes at the peaks of the sawtooth waveform.

The output ripple voltage is due mainly to the inductor sawtooth ripple current multiplied by the ESR of the output capacitor (see [Inductor Selection](#)).

The voltage spikes are present because of the fast switching action of the output switch, and the parasitic inductance of the output filter capacitor. To minimize these voltage spikes, special low inductance capacitors can be used, and their lead lengths must be kept short. Wiring inductance, stray capacitance, as well as the scope probe used to evaluate these transients, all contribute to the amplitude of these spikes.

An additional small LC filter (20 μ H and 100 μ F) can be added to the output (as shown in [Figure 18](#)) to further reduce the amount of output ripple and transients. A 10 \times reduction in output ripple voltage and transients is possible with this filter.

8.1.7 Feedback Connection

The LM2574 (fixed voltage versions) feedback pin must be wired to the output voltage point of the switching power supply. When using the adjustable version, physically locate both output voltage programming resistors near the LM2574 to avoid picking up unwanted noise. Avoid using resistors greater than 100 k Ω because of the increased chance of noise pickup.

8.1.8 $\overline{\text{ON/OFF}}$ Input

For normal operation, the $\overline{\text{ON/OFF}}$ pin must be grounded or driven with a low-level TTL voltage (typically less than 1.6 V). To put the regulator into standby mode, drive this pin with a high-level TTL or CMOS signal. The $\overline{\text{ON/OFF}}$ pin can be safely pulled up to $+V_{IN}$ without a resistor in series with it. The $\overline{\text{ON/OFF}}$ pin must not be left open.

8.1.9 Additional Applications

8.1.9.1 Inverting Regulator

Figure 20 shows a LM2574-12 in a buck-boost configuration to generate a negative 12-V output from a positive input voltage. This circuit bootstraps the ground pin of the regulator to the negative output voltage, then by grounding the feedback pin, the regulator senses the inverted output voltage and regulates it to -12 V.

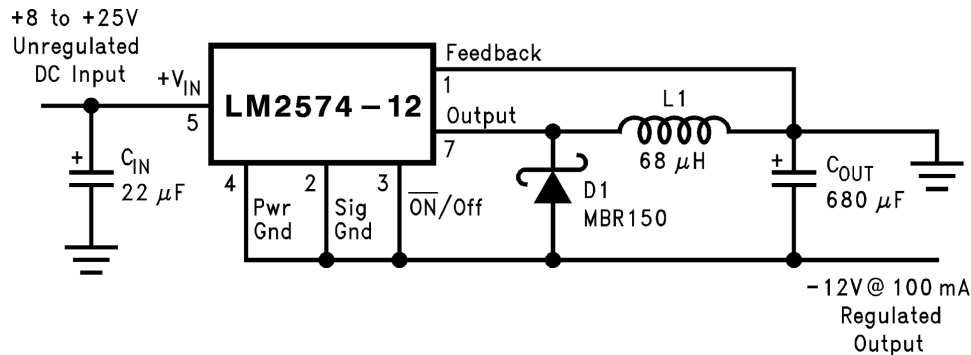

Note: Pin numbers are for the 8-pin PDIP package.

Figure 20. Inverting Buck-Boost Develops, 12 V

For an input voltage of 8 V or more, the maximum available output current in this configuration is approximately 100 mA. At lighter loads, the minimum input voltage required drops to approximately 4.7 V.

The switch currents in this buck-boost configuration are higher than in the standard buck-mode design, thus lowering the available output current. Also, the start-up input current of the buck-boost converter is higher than the standard buck-mode regulator, and this may overload an input power source with a current limit less than 0.6 A. Using a delayed turnon or an undervoltage lockout circuit (described in [Negative Boost Regulator](#)) would allow the input voltage to rise to a high enough level before the switcher would be allowed to turn on.

Because of the structural differences between the buck and the buck-boost regulator topologies, the design procedure can not be used to select the inductor or the output capacitor. The recommended range of inductor values for the buck-boost design is between 68 µH and 220 µH, and the output capacitor values must be larger than what is normally required for buck designs. Low-input voltages or high-output currents require a large value output capacitor (in the thousands of micro Farads).

The peak inductor current, which is the same as the peak switch current, can be calculated from [Equation 6](#).

$$I_P \approx \frac{I_{LOAD} \times (V_{IN} + |V_{OUT}|)}{V_{IN}} + \frac{V_{IN} \times |V_{OUT}|}{V_{IN} + |V_{OUT}|} \times \frac{1}{2 \times L_1 \times f_{OSC}}$$

where

- $f_{osc} = 52$ kHz. Under normal continuous inductor current operating conditions,
 - the minimum V_{IN} represents the worst case. Select an inductor that is rated for the peak current anticipated.
- (6)

Also, the maximum voltage appearing across the regulator is the absolute sum of the input and output voltage. For a -12-V output, the maximum input voltage for the LM2574 is 28 V, or 48 V for the LM2574HV.

8.1.9.2 Negative Boost Regulator

Another variation on the buck-boost topology is the negative boost configuration. The circuit in [Figure 21](#) accepts an input voltage ranging from -5 V to -12 V and provides a regulated -12-V output. Input voltages greater than -12 V causes the output to rise greater than -12 V, but does not damage the regulator.

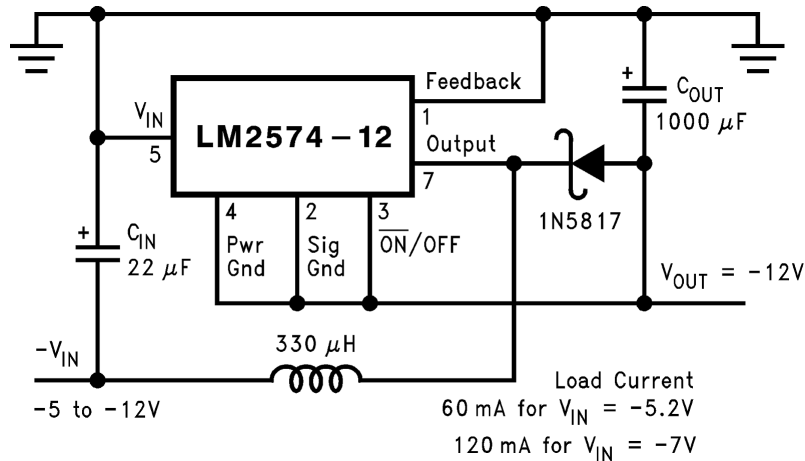

Note: Pin numbers are for 8-pin PDIP package.

Figure 21. Negative Boost

Because of the boosting function of this type of regulator, the switch current is relatively high, especially at low input voltages. Output load current limitations are a result of the maximum current rating of the switch. Also, boost regulators can not provide current-limiting load protection in the event of a shorted load, so some other means (such as a fuse) may be necessary.

8.2 Typical Applications

8.2.1 Fixed Output Voltage Applications

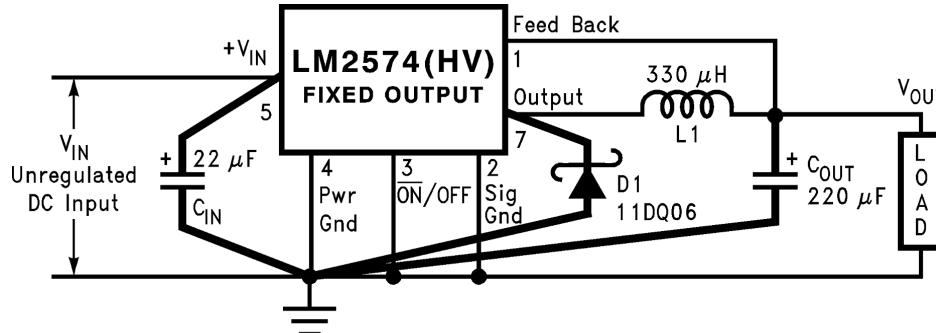

Copyright © 2016, Texas Instruments Incorporated

- C_{IN}: 22 µF, 75 V
Aluminum electrolytic
- C_{OUT}: 220 µF, 25 V
Aluminum electrolytic
- D1: Schottky, 11DQ06
- L1: 330 µH, 52627
(for 5 V in, 3.3 V out, use
100 µH, RL-1284-100)
- R1: 2k, 0.1%
- R2: 6.12k, 0.1%

Figure 22. Fixed Output Voltage Versions

Typical Applications (continued)

8.2.1.1 Design Requirements

The design requirements for the fixed output voltage application is provided in [Table 2](#).

Table 2. Design Parameters

PARAMETER	EXAMPLE VALUE
Regulated output voltage (3.3 V, 5 V, 12 V, or 15 V), V_{OUT}	5 V
Maximum input voltage, $V_{IN(Max)}$	15 V
Maximum load current, $I_{LOAD(Max)}$	0.4 A

8.2.1.2 Detailed Design Procedure

8.2.1.2.1 Custom Design With WEBENCH® Tools

[Click here](#) to create a custom design using the LM2574 device with the WEBENCH® Power Designer.

1. Start by entering the input voltage (V_{IN}), output voltage (V_{OUT}), and output current (I_{OUT}) requirements.
2. Optimize the design for key parameters such as efficiency, footprint, and cost using the optimizer dial.
3. Compare the generated design with other possible solutions from Texas Instruments.

The WEBENCH Power Designer provides a customized schematic along with a list of materials with real-time pricing and component availability.

In most cases, these actions are available:

- Run electrical simulations to see important waveforms and circuit performance
- Run thermal simulations to understand board thermal performance
- Export customized schematic and layout into popular CAD formats
- Print PDF reports for the design, and share the design with colleagues

Get more information about WEBENCH tools at www.ti.com/WEBENCH.

8.2.1.2.2 Inductor Selection (L1)

Select the correct Inductor value selection guide from [Figure 23](#), [Figure 24](#), [Figure 25](#), or [Figure 26](#) (output voltages of 3.3 V, 5 V, 12 V, or 15 V respectively).

From the inductor value selection guide, identify the inductance region intersected by $V_{IN(Max)}$ and $I_{LOAD(Max)}$. The inductance area intersected by the 15-V line and 0.4-A line is 330.

Select an appropriate inductor from [Table 3](#). Part numbers are listed for three inductor manufacturers. The inductor chosen must be rated for operation at the LM2574 switching frequency (52 kHz) and for a current rating of $1.5 \times I_{LOAD}$. For additional inductor information, see [Inductor Selection](#). The required inductor value is 330 μ H. From [Table 3](#), choose Pulse Engineering PE-52627, Renco RL-1284-330, or NPI NP5920/5921.

Table 3. Inductor Selection By Manufacturer's Part Number

INDUCTOR VALUE	PULSE ENG.	RENCO	NPI
68 μ H	*	RL-1284-68-43	NP5915
100 μ H	*	RL-1284-100-43	NP5916
150 μ H	52625	RL-1284-150-43	NP5917
220 μ H	52626	RL-1284-220-43	NP5918/5919
330 μ H	52627	RL-1284-330-43	NP5920/5921
470 μ H	52628	RL-1284-470-43	NP5922
680 μ H	52629	RL-1283-680-43	NP5923
1000 μ H	52631	RL-1283-1000-43	*
1500 μ H	*	RL-1283-1500-43	*
2200 μ H	*	RL-1283-2200-43	*

8.2.1.2.3 Output Capacitor Selection (C_{OUT})

The value of the output capacitor together with the inductor defines the dominate pole-pair of the switching regulator loop. For stable operation and an acceptable output ripple voltage, (approximately 1% of the output voltage) a value between 100 μ F and 470 μ F is recommended. $C_{OUT} = 100\text{-}\mu\text{F}$ to 470- μF standard aluminum electrolytic.

The voltage rating of the capacitor must be at least 1.5 times greater than the output voltage. For a 5-V regulator, a rating of at least 8 V is appropriate, and a 10-V or 15-V rating is recommended. Capacitor voltage rating = 20 V.

Higher voltage electrolytic capacitors generally have lower ESR numbers, and for this reason it may be necessary to select a capacitor rated for a higher voltage than would normally be needed.

LM2574, LM2574HV

SNVS104E –JUNE 1999–REVISED JULY 2018

www.ti.com

8.2.1.2.4 Catch Diode Selection (D1)

The catch-diode current rating must be at least 1.5 times greater than the maximum load current. Also, if the power supply design must withstand a continuous output short, the diode must have a current rating equal to the maximum current limit of the LM2574. The most stressful condition for this diode is an overload or shorted output condition. For this example, a 1-A current rating is adequate.

The reverse voltage rating of the diode must be at least 1.25 times the maximum input voltage. Use a 20-V 1N5817 or SR102 Schottky diode, or any of the suggested fast-recovery diodes shown in [Table 1](#).

8.2.1.2.5 Input Capacitor (C_{IN})

An aluminum or tantalum electrolytic bypass capacitor located close to the regulator is needed for stable operation. A 22- μ F aluminum electrolytic capacitor located near the input and ground pins provides sufficient bypassing.

8.2.1.3 Application Curves

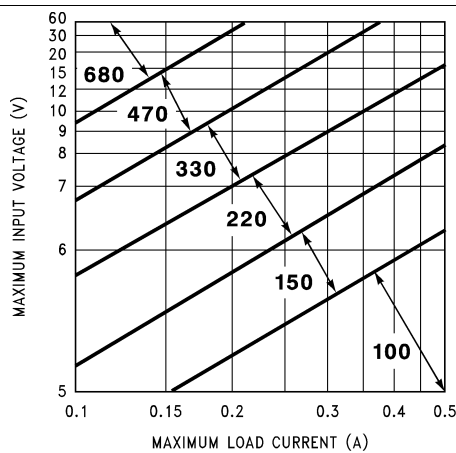

Figure 23. 3.3-V LM2574HV Inductor Selection Guide

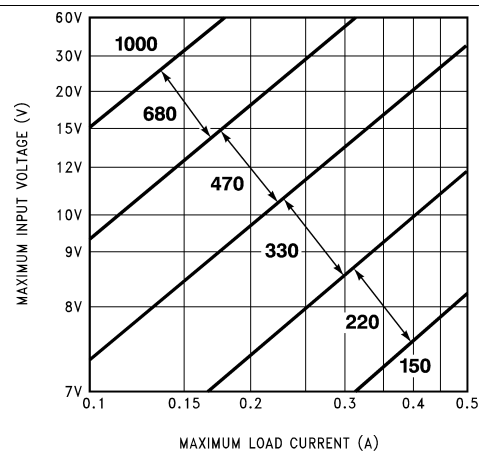

Figure 24. 5-V LM2574HV Inductor Selection Guide

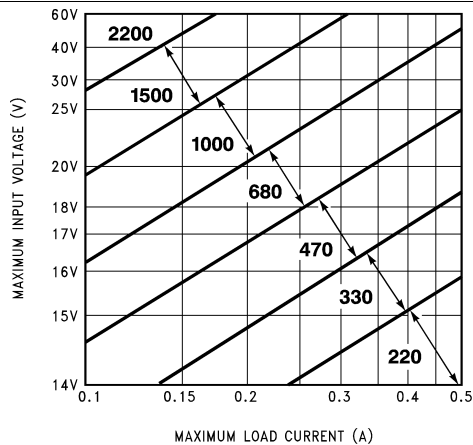

Figure 25. 12-V LM2574HV Inductor Selection Guide

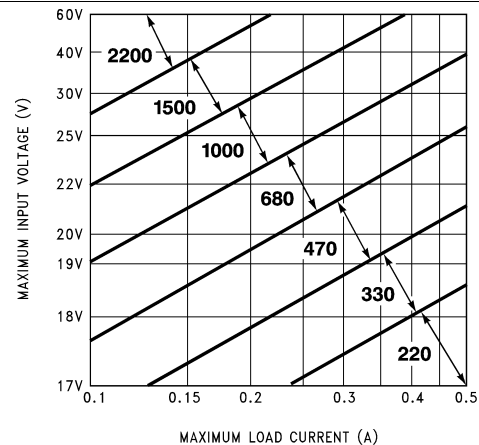

Figure 26. 15-V LM2574HV Inductor Selection Guide

8.2.2 Adjustable Output Voltage Applications

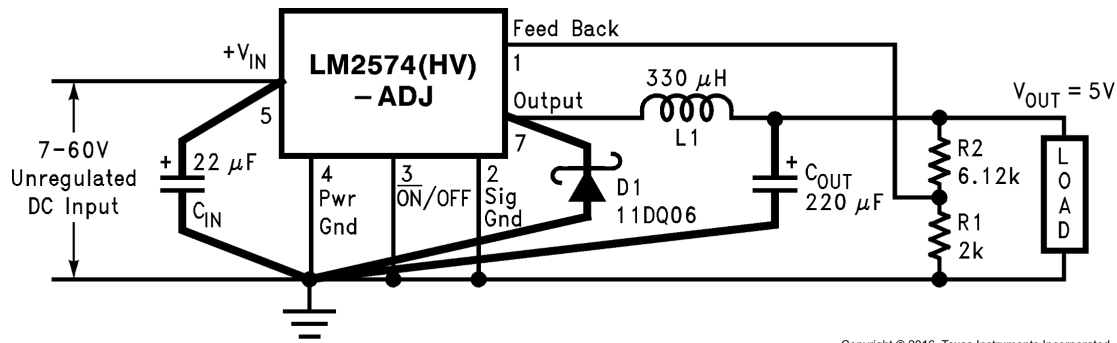

Figure 27. Adjustable Output Voltage Version

8.2.2.1 Design Requirements

The design requirements for the fixed output voltage application is provided in [Table 4](#).

Table 4. Design Parameters

PARAMETER	EXAMPLE VALUE
Regulated output voltage, V_{OUT}	24 V
Maximum input voltage, $V_{IN(Max)}$	40 V
Maximum load current, $I_{LOAD(Max)}$	0.4 A
Switching frequency, F	52 kHz

8.2.2.2 Detailed Design Procedure

8.2.2.2.1 Programming Output Voltage

Selecting R1 and R2, as shown in [Figure 27](#).

Use [Equation 7](#) to select the appropriate resistor values.

$$V_{OUT} = V_{REF} \times \left(1 + \frac{R_2}{R_1}\right)$$

where

- $V_{REF} = 1.23 \text{ V}$ (7)

R_1 can be between 1k and 5k as in [Equation 8](#). For best temperature coefficient and stability with time, use 1% metal film resistors.

$$R_2 = R_1 \times \left(\frac{V_{OUT}}{V_{REF}} - 1\right)$$
 (8)

For this example, use [Equation 9](#) and [Equation 10](#).

$$V_{OUT} = 1.23 \times \left(1 + \frac{R_2}{R_1}\right)$$

select

- $R_1 = 1\text{k}$ (9)

$$R_2 = R_1 \times \left(\frac{V_{OUT}}{V_{REF}} - 1\right) = 1\text{k} \times \left(\frac{24 \text{ V}}{1.23 \text{ V}} - 1\right)$$
 (10)

$R_2 = 1\text{k} (19.51 - 1) = 18.51\text{k}$, closest 1% value is 18.7k

8.2.2.2.2 Inductor Selection (L1)

Calculate the inductor Volt × microsecond constant, $E \times T$ ($V \times \mu s$), from [Equation 11](#).

$$E \times T = (V_{IN} - V_{OUT}) \times \frac{V_{OUT}}{V_{IN}} \times \frac{1000}{F(\text{kHz})} (V \times \mu s) \quad (11)$$

For this example, calculate $E \times T$ ($V \times \mu s$) using [Equation 12](#).

$$E \times T = (40 - 24) \times \frac{24}{40} \times \frac{1000}{52} = 185 V \times \mu s \quad (12)$$

Use the $E \times T$ value from the previous formula and match it with the $E \times T$ number on the vertical axis of the inductor value selection guide shown in [Figure 32](#). For this example, $E \times T = 185 V \times \mu s$.

On the horizontal axis, select the maximum load current, $I_{LOAD}(\text{Max}) = 0.4 A$.

Identify the inductance region intersected by the $E \times T$ value and the maximum load current value, and note the inductor value for that region, inductance region = 1000.

Select an appropriate inductor from the table shown in [Table 3](#). Part numbers are listed for three inductor manufacturers. The inductor chosen must be rated for operation at the LM2574 switching frequency (52 kHz) and for a current rating of $1.5 \times I_{LOAD}$. For additional inductor information, see [Inductor Selection](#).

8.2.2.2.3 Output Capacitor Selection (C_{OUT})

The value of the output capacitor together with the inductor defines the dominate pole-pair of the switching regulator loop. For stable operation, the capacitor must satisfy the requirement in [Equation 13](#).

$$C_{OUT} \geq 13300 \times \frac{V_{IN(\text{MAX})}}{V_{OUT} \times L(\mu H)} (\mu F) \quad (13)$$

[Equation 13](#) yields capacitor values between 5 μF and 1000 μF that satisfies the loop requirements for stable operation. But to achieve an acceptable output ripple voltage, (approximately 1% of the output voltage) and transient response, the output capacitor may need to be several times larger than the above formula yields.

The voltage rating of the capacitor must be at least 1.5 times greater than the output voltage. For a 24-V regulator, a rating of at least 35 V is recommended. Higher voltage electrolytic capacitors generally have lower ESR numbers, and for this reason it may be necessary to select a capacitor rate for a higher voltage than would normally be needed.

$$C_{OUT} > 13300 \times \frac{40}{24 \times 1000} = 22.2 \mu F \quad (14)$$

However, for acceptable output ripple voltage select:

$$C_{OUT} \geq 100 \mu F$$

$C_{OUT} = 100 \mu F$ electrolytic capacitor

8.2.2.2.4 Catch Diode Selection (D1)

The catch-diode current rating must be at least 1.5 times greater than the maximum load current. Also, if the power supply design must withstand a continuous output short, the diode must have a current rating equal to the maximum current limit of the LM2574. The most stressful condition for this diode is an overload or shorted output condition. Suitable diodes are shown in [Table 1](#). For this example, a 1-A current rating is adequate.

The reverse voltage rating of the diode must be at least 1.25 times the maximum input voltage. Use a 50-V MBR150 or 11DQ05 Schottky diode, or any of the suggested fast-recovery diodes in [Table 1](#).

8.2.2.2.5 Input Capacitor (C_{IN})

An aluminum or tantalum electrolytic bypass capacitor located close to the regulator is needed for stable operation. A 22- μF aluminum electrolytic capacitor located near the input and ground pins provides sufficient bypassing (see [Table 1](#)).

8.2.2.3 Application Curves

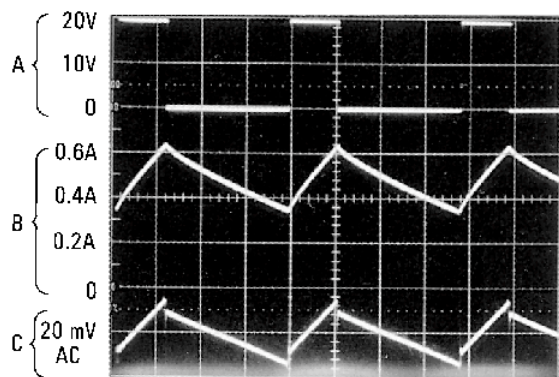

Output pin voltage, 10 V/div,
Inductor current, 0.2 A/div,
Output ripple voltage,
20 mV/div,
AC-coupled
Horizontal time base,
5 μ s/div,
 $V_{OUT} = 5$ V,
500-mA load current,
L = 330 Mh

Figure 28. Continuous Mode Switching Waveforms

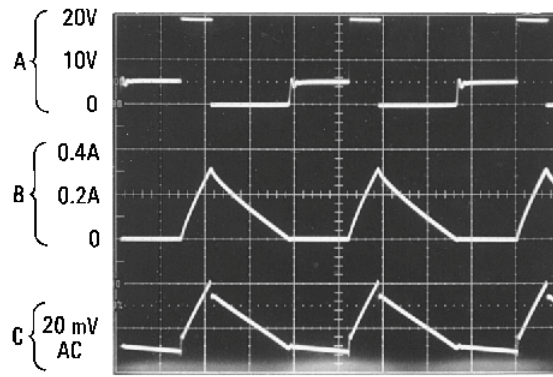

Output pin voltage, 10 V/div,
Inductor current, 0.2 A/div,
Output ripple voltage,
20 mV/div,
AC-coupled
Horizontal time base,
5 μ s/div,
 $V_{OUT} = 5$ V,
100-mA load current,
L = 100 Mh

Figure 29. Discontinuous Mode Switching Waveforms

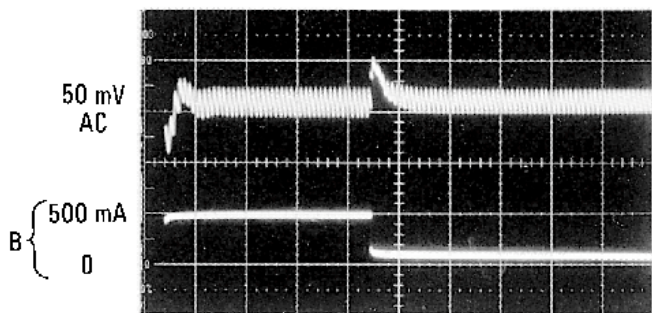

Output voltage, 50 V/div,
AC-coupled,
100-mA to 500-mA load pulse,
Horizontal time base: 200 μ s/div
500 mA load,
L = 330 Mh,
 $C_{OUT} = 300$ Mf,

Figure 30. Transient Response for Continuous Mode Operation

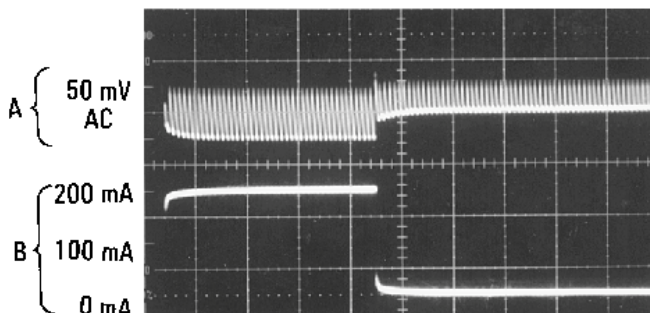

Output voltage, 50 V/div,
AC-coupled,
50-mA to 250-mA load pulse,
Horizontal time base: 200 μ s/div
250 mA load,
L = 68 Mh,
 $C_{OUT} = 470$ Mf,

Figure 31. Transient Response for Discontinuous Mode Operation

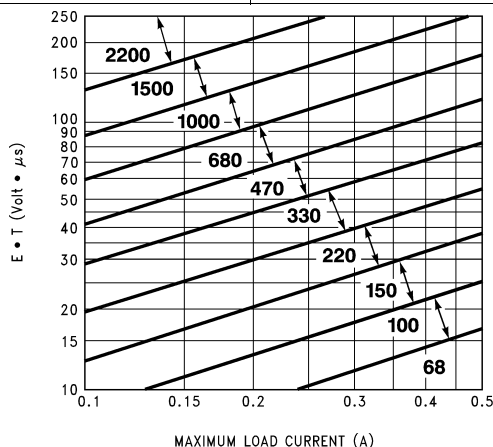

Figure 32. Adjustable LM2574HV Inductor Selection Guide

9 Power Supply Recommendations

As in any switching regulator, layout is very important. Rapidly switching currents associated with wiring inductance generate voltage transients which can cause problems. For minimal inductance and ground loops, the length of the leads indicated by heavy lines must be kept as short as possible. Single-point grounding (as indicated) or ground plane construction must be used for best results. When using the adjustable version, physically locate the programming resistors near the regulator, to keep the sensitive feedback wiring short.

10 Layout

10.1 Layout Guidelines

The layout is critical for the proper operation of switching power supplies. First, the ground plane area must be sufficient for thermal dissipation purposes. Second, appropriate guidelines must be followed to reduce the effects of switching noise. Switch mode converters are very fast switching devices. In such cases, the rapid increase of input current combined with the parasitic trace inductance generates unwanted $L di/dt$ noise spikes. The magnitude of this noise tends to increase as the output current increases. This noise may turn into electromagnetic interference (EMI) and can also cause problems in device performance. Therefore, take care in the layout to minimize the effect of this switching noise.

The most important layout rule is to keep the AC current loops as small as possible. [Figure 33](#) shows the current flow in a buck converter. The top schematic shows a dotted line which represents the current flow during the top switch ON-state. The middle schematic shows the current flow during the top switch OFF-state. The bottom schematic shows the currents referred to as AC currents. These AC currents are the most critical because they are changing in a very short time period. The dotted lines of the bottom schematic are the traces to keep as short and wide as possible. This also yields a small loop area reducing the loop inductance. To avoid functional problems due to layout, review the PCB layout example. Best results are achieved if the placement of the LM2574 device, the bypass capacitor, the Schottky diode, RFBB, RFBT, and the inductor are placed as shown in the example. In the layout shown, R1 = RFBB and R2 = RFBT. TI also recommends using 2-oz. copper boards or heavier to help thermal dissipation and to reduce the parasitic inductances of board traces. See the application note [AN-1229 SIMPLE SWITCHER® PCB Layout Guidelines \(SNVA054\)](#) for more information.

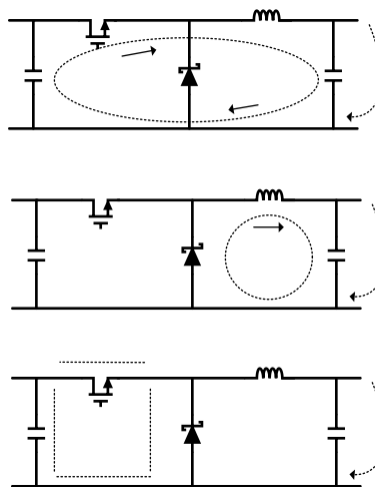
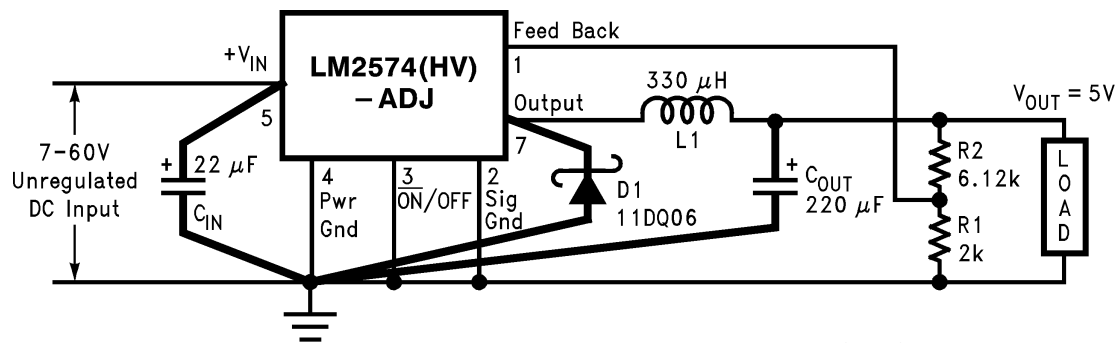

Figure 33. Buck Converter Current Flow

10.2 Layout Example



Copyright © 2016, Texas Instruments Incorporated

Figure 34. LM2574 Adjustable Output Voltage Layout

10.3 Grounding

The 8-pin molded PDIP and the 14-pin SOIC package have separate power and signal ground pins. Both ground pins must be soldered directly to wide printed-circuit board copper traces to assure low inductance connections and good thermal properties.

10.4 Thermal Considerations

The 8-pin PDIP (P) package and the 14-pin SOIC (NPA) package are molded plastic packages with solid copper lead frames. The copper lead frame conducts the majority of the heat from the die, through the leads, to the printed-circuit board copper, which acts as the heat sink. For best thermal performance, wide copper traces must be used, and all ground and unused pins must be soldered to generous amounts of printed-circuit board copper, such as a ground plane. Large areas of copper provide the best transfer of heat (lower thermal resistance) to the surrounding air, and even double-sided or multilayer boards provide better heat paths to the surrounding air. Unless the power levels are small, using a socket for the 8-pin package is not recommended because of the additional thermal resistance it introduces, and the resultant higher junction temperature.

Because of the 0.5-A current rating of the LM2574, the total package power dissipation for this switcher is quite low, ranging from approximately 0.1 W up to 0.75 W under varying conditions. In a carefully engineered printed-circuit board, both the P and the NPA package can easily dissipate up to 0.75 W, even at ambient temperatures of 60°C, and still keep the maximum junction temperature less than 125°C.

A curve, [Figure 14](#), displaying thermal resistance versus PCB area for the two packages is shown in [Typical Characteristics](#).

These thermal resistance numbers are approximate, and there can be many factors that affect the final thermal resistance. Some of these factors include board size, shape, thickness, position, location, and board temperature. Other factors are, the area of printed-circuit copper, copper thickness, trace width, multi-layer, single- or double-sided, and the amount of solder on the board. The effectiveness of the PCB to dissipate heat also depends on the size, number and spacing of other components on the board. Furthermore, some of these components, such as the catch diode and inductor generate some additional heat. Also, the thermal resistance decreases as the power level increases because of the increased air current activity at the higher power levels, and the lower surface to air resistance coefficient at higher temperatures.

The data sheet thermal resistance curves can estimate the maximum junction temperature based on operating conditions. In addition, the junction temperature can be estimated in actual circuit operation by using [Equation 15](#).

$$T_j = T_{cu} + (\theta_{j-cu} \times P_D) \quad (15)$$

Thermal Considerations (continued)

With the switcher operating under worst case conditions and all other components on the board in the intended enclosure, measure the copper temperature (T_{cu}) near the IC. This can be done by temporarily soldering a small thermocouple to the PCB copper near the IC, or by holding a small thermocouple on the PCB copper using thermal grease for good thermal conduction.

The thermal resistance (θ_{j-cu}) for the two packages is:

$$\theta_{j-cu} = 42^{\circ}\text{C/W for the P-8 package}$$

$$\theta_{j-cu} = 52^{\circ}\text{C/W for the NPA-14 package}$$

The power dissipation (P_D) for the IC could be measured, or it can be estimated by using [Equation 16](#).

$$P_D = V_{IN} \times I_S + \frac{V_{OUT}}{V_{IN}} \times I_{LOAD} \times V_{SAT}$$

where

- I_S is obtained from the typical supply current curve (adjustable version use the supply current vs duty cycle curve) (16)

11 Device and Documentation Support

11.1 Device Support

11.1.1 Third-Party Products Disclaimer

TI'S PUBLICATION OF INFORMATION REGARDING THIRD-PARTY PRODUCTS OR SERVICES DOES NOT CONSTITUTE AN ENDORSEMENT REGARDING THE SUITABILITY OF SUCH PRODUCTS OR SERVICES OR A WARRANTY, REPRESENTATION OR ENDORSEMENT OF SUCH PRODUCTS OR SERVICES, EITHER ALONE OR IN COMBINATION WITH ANY TI PRODUCT OR SERVICE.

11.1.2 Custom Design With WEBENCH® Tools

[Click here](#) to create a custom design using the LM2574 device with the WEBENCH® Power Designer.

1. Start by entering the input voltage (V_{IN}), output voltage (V_{OUT}), and output current (I_{OUT}) requirements.
2. Optimize the design for key parameters such as efficiency, footprint, and cost using the optimizer dial.
3. Compare the generated design with other possible solutions from Texas Instruments.

The WEBENCH Power Designer provides a customized schematic along with a list of materials with real-time pricing and component availability.

In most cases, these actions are available:

- Run electrical simulations to see important waveforms and circuit performance
- Run thermal simulations to understand board thermal performance
- Export customized schematic and layout into popular CAD formats
- Print PDF reports for the design, and share the design with colleagues

Get more information about WEBENCH tools at www.ti.com/WEBENCH.

11.1.3 Device Nomenclature

11.1.3.1 Buck Regulator

A switching regulator topology in which a higher voltage is converted to a lower voltage. Also known as a step-down switching regulator.

11.1.3.2 Buck-Boost Regulator

A switching regulator topology in which a positive voltage is converted to a negative voltage without a transformer.

11.1.3.3 Duty Cycle (D)

The ratio of the ON-time of the output switch to the oscillator period calculated with [Equation 17](#) for buck regulators and [Equation 18](#) for buck-boost regulators.

$$D = \frac{t_{ON}}{T} = \frac{V_{OUT}}{V_{IN}} \quad (17)$$

$$D = \frac{t_{ON}}{T} = \frac{|V_{OUT}|}{|V_{OUT}| + V_{IN}} \quad (18)$$

11.1.3.4 Catch Diode or Current Steering Diode

This diode provides a return path for the load current when the LM2574 switch is OFF.

In terms of efficiency (η), the proportion of input power actually delivered to the load calculated with [Equation 19](#).

$$\eta = \frac{P_{OUT}}{P_{IN}} = \frac{P_{OUT}}{P_{OUT} + P_{LOSS}} \quad (19)$$

Device Support (continued)

11.1.3.5 Capacitor Equivalent Series Resistance (ESR)

The purely resistive component of a real capacitor's impedance (see [Figure 35](#)) can cause power loss resulting in capacitor heating, which directly affects the operating lifetime of the capacitor. When used as a switching regulator output filter, higher ESR values result in higher output ripple voltages.



Figure 35. Simple Model Of A Real Capacitor

Most standard aluminum electrolytic capacitors in the 100 μF to 1000 μF range have 0.5- Ω to 0.1- Ω ESR. Higher-grade capacitors (*low-ESR, high-frequency, or low-inductance*) in the 100 μF to 1000 μF range generally have ESR of less than 0.15 Ω .

11.1.3.6 Equivalent Series Inductance (ESL)

The pure inductance component of a capacitor is seen in [Figure 35](#). The amount of inductance is determined to a large extent on the capacitor's construction. In a buck regulator, this unwanted inductance causes voltage spikes to appear on the output.

11.1.3.7 Output Ripple Voltage

The AC component of the output voltage of the switching regulator is usually dominated by the output capacitor's ESR multiplied by the inductor's ripple current (ΔI_{IND}). The peak-to-peak value of this sawtooth ripple current can be determined by reading [Inductor Ripple Current \(\$\Delta I_{\text{IND}}\$ \)](#).

11.1.3.8 Capacitor Ripple Current

The RMS value of the maximum allowable alternating current at which a capacitor can be operated continuously at a specified temperature.

11.1.3.9 Standby Quiescent Current (I_{STBY})

Supply current required by the LM2574 when in the standby mode ($\overline{\text{ON/OFF}}$ pin is driven to TTL-high voltage, thus turning the output switch OFF).

11.1.3.10 Inductor Ripple Current (ΔI_{IND})

The peak-to-peak value of the inductor current waveform, typically a sawtooth waveform when the regulator is operating in the continuous mode (vs. discontinuous mode).

11.1.3.11 Continuous and Discontinuous Mode Operation

These mode operations relate to the inductor current. In the continuous mode, the inductor current is always flowing and never drops to zero, versus the discontinuous mode, where the inductor current drops to zero for a period of time in the normal switching cycle.

11.1.3.12 Inductor Saturation

The condition which exists when an inductor cannot hold any more magnetic flux. When an inductor saturates, the inductor appears less inductive and the resistive component dominates. Inductor current is then limited only by the DC resistance of the wire and the available source current.

11.1.3.13 Operating Volt Microsecond Constant ($E \times T_{\text{op}}$)

The product (in Volt \times μs) of the voltage applied to the inductor and the time the voltage is applied. This $E \times T_{\text{op}}$ constant is a measure of the energy handling capability of an inductor and is dependent upon the type of core, the core area, the number of turns, and the duty cycle.

11.2 Documentation Support

11.2.1 Related Documentation

For related documentation see the following:

AN-1229 SIMPLE SWITCHER® PCB Layout Guidelines, [SNVA054](#)

11.3 Receiving Notification of Documentation Updates

To receive notification of documentation updates, navigate to the device product folder on ti.com. In the upper right corner, click on *Alert me* to register and receive a weekly digest of any product information that has changed. For change details, review the revision history included in any revised document.

11.4 Community Resources

The following links connect to TI community resources. Linked contents are provided "AS IS" by the respective contributors. They do not constitute TI specifications and do not necessarily reflect TI's views; see TI's [Terms of Use](#).

TI E2E™ Online Community *TI's Engineer-to-Engineer (E2E) Community*. Created to foster collaboration among engineers. At e2e.ti.com, you can ask questions, share knowledge, explore ideas and help solve problems with fellow engineers.

Design Support *TI's Design Support* Quickly find helpful E2E forums along with design support tools and contact information for technical support.

11.5 Trademarks

E2E is a trademark of Texas Instruments.

WEBENCH, SIMPLE SWITCHER are registered trademarks of Texas Instruments.

All other trademarks are the property of their respective owners.

11.6 Electrostatic Discharge Caution



These devices have limited built-in ESD protection. The leads should be shorted together or the device placed in conductive foam during storage or handling to prevent electrostatic damage to the MOS gates.

11.7 Glossary

[SLYZ022](#) — *TI Glossary*.

This glossary lists and explains terms, acronyms, and definitions.

12 Mechanical, Packaging, and Orderable Information

The following pages include mechanical, packaging, and orderable information. This information is the most current data available for the designated devices. This data is subject to change without notice and revision of this document. For browser-based versions of this data sheet, refer to the left-hand navigation.

PACKAGING INFORMATION

Orderable Device	Status (1)	Package Type	Package Drawing	Pins	Package Qty	Eco Plan (2)	Lead/Ball Finish (6)	MSL Peak Temp (3)	Op Temp (°C)	Device Marking (4/5)	Samples
LM2574HVM-12/NOPB	ACTIVE	SOIC	NPA	14	50	Green (RoHS & no Sb/Br)	CU SN	Level-3-260C-168 HR	-40 to 125	LM2574HVM -12 P+	Samples
LM2574HVM-15	NRND	SOIC	NPA	14	50	TBD	Call TI	Call TI	-40 to 125	LM2574HVM -15 P+	
LM2574HVM-15/NOPB	ACTIVE	SOIC	NPA	14	50	Green (RoHS & no Sb/Br)	CU SN	Level-3-260C-168 HR	-40 to 125	LM2574HVM -15 P+	Samples
LM2574HVM-3.3/NOPB	ACTIVE	SOIC	NPA	14	50	Green (RoHS & no Sb/Br)	CU SN	Level-3-260C-168 HR	-40 to 125	LM2574HVM -3.3 P+	Samples
LM2574HVM-5.0	NRND	SOIC	NPA	14	50	TBD	Call TI	Call TI	-40 to 125	LM2574HVM -5.0 P+	
LM2574HVM-5.0/NOPB	ACTIVE	SOIC	NPA	14	50	Green (RoHS & no Sb/Br)	CU SN	Level-3-260C-168 HR	-40 to 125	LM2574HVM -5.0 P+	Samples
LM2574HVM-ADJ/NOPB	ACTIVE	SOIC	NPA	14	50	Green (RoHS & no Sb/Br)	CU SN	Level-3-260C-168 HR	-40 to 125	LM2574HVM -ADJ P+	Samples
LM2574HVMX-12/NOPB	ACTIVE	SOIC	NPA	14	1000	Green (RoHS & no Sb/Br)	CU SN	Level-3-260C-168 HR	-40 to 125	LM2574HVM -12 P+	Samples
LM2574HVMX-15/NOPB	ACTIVE	SOIC	NPA	14	1000	Green (RoHS & no Sb/Br)	CU SN	Level-3-260C-168 HR	-40 to 125	LM2574HVM -15 P+	Samples
LM2574HVMX-3.3/NOPB	ACTIVE	SOIC	NPA	14	1000	Green (RoHS & no Sb/Br)	CU SN	Level-4-260C-72 HR	-40 to 125	LM2574HVM -3.3 P+	Samples
LM2574HVMX-5.0	NRND	SOIC	NPA	14	1000	TBD	Call TI	Call TI	-40 to 125	LM2574HVM -5.0 P+	
LM2574HVMX-5.0/NOPB	ACTIVE	SOIC	NPA	14	1000	Green (RoHS & no Sb/Br)	CU SN	Level-3-260C-168 HR	-40 to 125	LM2574HVM -5.0 P+	Samples
LM2574HVMX-ADJ/NOPB	ACTIVE	SOIC	NPA	14	1000	Green (RoHS & no Sb/Br)	CU SN	Level-3-260C-168 HR	-40 to 125	LM2574HVM -ADJ P+	Samples
LM2574HVN-12/NOPB	ACTIVE	PDIP	P	8	40	Green (RoHS & no Sb/Br)	CU SN	Level-1-NA-UNLIM	-40 to 125	LM2574HVN -12 P+	Samples
LM2574HVN-15/NOPB	ACTIVE	PDIP	P	8	40	Green (RoHS & no Sb/Br)	CU SN	Level-1-NA-UNLIM	-40 to 125	LM2574HVN -15 P+	Samples
LM2574HVN-5.0/NOPB	ACTIVE	PDIP	P	8	40	Green (RoHS & no Sb/Br)	CU SN	Level-1-NA-UNLIM	-40 to 125	LM2574HVN -5.0 P+	Samples
LM2574HVN-ADJ/NOPB	ACTIVE	PDIP	P	8	40	Green (RoHS & no Sb/Br)	CU SN	Level-1-NA-UNLIM	-40 to 125	LM2574HVN -ADJ P+	Samples

Orderable Device	Status (1)	Package Type	Package Drawing	Pins	Package Qty	Eco Plan (2)	Lead/Ball Finish (6)	MSL Peak Temp (3)	Op Temp (°C)	Device Marking (4/5)	Samples
LM2574M-12/NOPB	ACTIVE	SOIC	NPA	14	50	Green (RoHS & no Sb/Br)	CU SN	Level-3-260C-168 HR	-40 to 125	LM2574M -12 P+	Samples
LM2574M-3.3/NOPB	ACTIVE	SOIC	NPA	14	50	Green (RoHS & no Sb/Br)	CU SN	Level-3-260C-168 HR	-40 to 125	LM2574M -3.3 P+	Samples
LM2574M-5.0	NRND	SOIC	NPA	14	50	TBD	Call TI	Call TI	-40 to 125	LM2574M -5.0 P+	
LM2574M-5.0/NOPB	ACTIVE	SOIC	NPA	14	50	Green (RoHS & no Sb/Br)	CU SN	Level-3-260C-168 HR	-40 to 125	LM2574M -5.0 P+	Samples
LM2574M-ADJ	NRND	SOIC	NPA	14	50	TBD	Call TI	Call TI	-40 to 125	LM2574M -ADJ P+	
LM2574M-ADJ/NOPB	ACTIVE	SOIC	NPA	14	50	Green (RoHS & no Sb/Br)	CU SN	Level-3-260C-168 HR	-40 to 125	LM2574M -ADJ P+	Samples
LM2574MX-12/NOPB	ACTIVE	SOIC	NPA	14	1000	Green (RoHS & no Sb/Br)	CU SN	Level-3-260C-168 HR	-40 to 125	LM2574M -12 P+	Samples
LM2574MX-3.3/NOPB	ACTIVE	SOIC	NPA	14	1000	Green (RoHS & no Sb/Br)	CU SN	Level-4-260C-72 HR	-40 to 125	LM2574M -3.3 P+	Samples
LM2574MX-5.0/NOPB	ACTIVE	SOIC	NPA	14	1000	Green (RoHS & no Sb/Br)	CU SN	Level-3-260C-168 HR	-40 to 125	LM2574M -5.0 P+	Samples
LM2574MX-ADJ/NOPB	ACTIVE	SOIC	NPA	14	1000	Green (RoHS & no Sb/Br)	CU SN	Level-3-260C-168 HR	-40 to 125	LM2574M -ADJ P+	Samples
LM2574N-12/NOPB	ACTIVE	PDIP	P	8	40	Green (RoHS & no Sb/Br)	CU SN	Level-1-NA-UNLIM	-40 to 125	LM2574N -12 P+	Samples
LM2574N-3.3/NOPB	ACTIVE	PDIP	P	8	40	Green (RoHS & no Sb/Br)	CU SN	Level-1-NA-UNLIM	-40 to 125	LM2574N -3.3 P+	Samples
LM2574N-5.0/NOPB	ACTIVE	PDIP	P	8	40	Green (RoHS & no Sb/Br)	CU SN	Level-1-NA-UNLIM	-40 to 125	LM2574N -5.0 P+	Samples
LM2574N-ADJ/NOPB	ACTIVE	PDIP	P	8	40	Green (RoHS & no Sb/Br)	CU SN	Level-1-NA-UNLIM	-40 to 125	LM2574N -ADJ P+	Samples

(1) The marketing status values are defined as follows:

ACTIVE: Product device recommended for new designs.

LIFEBUY: TI has announced that the device will be discontinued, and a lifetime-buy period is in effect.

NRND: Not recommended for new designs. Device is in production to support existing customers, but TI does not recommend using this part in a new design.

PREVIEW: Device has been announced but is not in production. Samples may or may not be available.

OBSOLETE: TI has discontinued the production of the device.

(2) **RoHS:** TI defines "RoHS" to mean semiconductor products that are compliant with the current EU RoHS requirements for all 10 RoHS substances, including the requirement that RoHS substance do not exceed 0.1% by weight in homogeneous materials. Where designed to be soldered at high temperatures, "RoHS" products are suitable for use in specified lead-free processes. TI may reference these types of products as "Pb-Free".

RoHS Exempt: TI defines "RoHS Exempt" to mean products that contain lead but are compliant with EU RoHS pursuant to a specific EU RoHS exemption.

Green: TI defines "Green" to mean the content of Chlorine (Cl) and Bromine (Br) based flame retardants meet JS709B low halogen requirements of ≤ 1000 ppm threshold. Antimony trioxide based flame retardants must also meet the ≤ 1000 ppm threshold requirement.

(3) MSL, Peak Temp. - The Moisture Sensitivity Level rating according to the JEDEC industry standard classifications, and peak solder temperature.

(4) There may be additional marking, which relates to the logo, the lot trace code information, or the environmental category on the device.

(5) Multiple Device Markings will be inside parentheses. Only one Device Marking contained in parentheses and separated by a "~" will appear on a device. If a line is indented then it is a continuation of the previous line and the two combined represent the entire Device Marking for that device.

(6) Lead/Ball Finish - Orderable Devices may have multiple material finish options. Finish options are separated by a vertical ruled line. Lead/Ball Finish values may wrap to two lines if the finish value exceeds the maximum column width.

Important Information and Disclaimer: The information provided on this page represents TI's knowledge and belief as of the date that it is provided. TI bases its knowledge and belief on information provided by third parties, and makes no representation or warranty as to the accuracy of such information. Efforts are underway to better integrate information from third parties. TI has taken and continues to take reasonable steps to provide representative and accurate information but may not have conducted destructive testing or chemical analysis on incoming materials and chemicals. TI and TI suppliers consider certain information to be proprietary, and thus CAS numbers and other limited information may not be available for release.

In no event shall TI's liability arising out of such information exceed the total purchase price of the TI part(s) at issue in this document sold by TI to Customer on an annual basis.

TAPE AND REEL INFORMATION

QUADRANT ASSIGNMENTS FOR PIN 1 ORIENTATION IN TAPE

*All dimensions are nominal

Device	Package Type	Package Drawing	Pins	SPQ	Reel Diameter (mm)	Reel Width W1 (mm)	A0 (mm)	B0 (mm)	K0 (mm)	P1 (mm)	W (mm)	Pin1 Quadrant
LM2574HVMX-12/NOPB	SOIC	NPA	14	1000	330.0	16.4	10.9	9.5	3.2	12.0	16.0	Q1
LM2574HVMX-15/NOPB	SOIC	NPA	14	1000	330.0	16.4	10.9	9.5	3.2	12.0	16.0	Q1
LM2574HVMX-3.3/NOPB	SOIC	NPA	14	1000	330.0	16.4	10.9	9.5	3.2	12.0	16.0	Q1
LM2574HVMX-5.0	SOIC	NPA	14	1000	330.0	16.4	10.9	9.5	3.2	12.0	16.0	Q1
LM2574HVMX-5.0/NOPB	SOIC	NPA	14	1000	330.0	16.4	10.9	9.5	3.2	12.0	16.0	Q1
LM2574HVMX-ADJ/NOPB	SOIC	NPA	14	1000	330.0	16.4	10.9	9.5	3.2	12.0	16.0	Q1
LM2574MX-12/NOPB	SOIC	NPA	14	1000	330.0	16.4	10.9	9.5	3.2	12.0	16.0	Q1
LM2574MX-3.3/NOPB	SOIC	NPA	14	1000	330.0	16.4	10.9	9.5	3.2	12.0	16.0	Q1
LM2574MX-5.0/NOPB	SOIC	NPA	14	1000	330.0	16.4	10.9	9.5	3.2	12.0	16.0	Q1
LM2574MX-ADJ/NOPB	SOIC	NPA	14	1000	330.0	16.4	10.9	9.5	3.2	12.0	16.0	Q1

TAPE AND REEL BOX DIMENSIONS

*All dimensions are nominal

Device	Package Type	Package Drawing	Pins	SPQ	Length (mm)	Width (mm)	Height (mm)
LM2574HVMX-12/NOPB	SOIC	NPA	14	1000	367.0	367.0	38.0
LM2574HVMX-15/NOPB	SOIC	NPA	14	1000	367.0	367.0	38.0
LM2574HVMX-3.3/NOPB	SOIC	NPA	14	1000	367.0	367.0	38.0
LM2574HVMX-5.0	SOIC	NPA	14	1000	367.0	367.0	38.0
LM2574HVMX-5.0/NOPB	SOIC	NPA	14	1000	367.0	367.0	38.0
LM2574HVMX-ADJ/NOPB	SOIC	NPA	14	1000	367.0	367.0	38.0
LM2574MX-12/NOPB	SOIC	NPA	14	1000	367.0	367.0	38.0
LM2574MX-3.3/NOPB	SOIC	NPA	14	1000	367.0	367.0	38.0
LM2574MX-5.0/NOPB	SOIC	NPA	14	1000	367.0	367.0	38.0
LM2574MX-ADJ/NOPB	SOIC	NPA	14	1000	367.0	367.0	38.0

NPA0014B

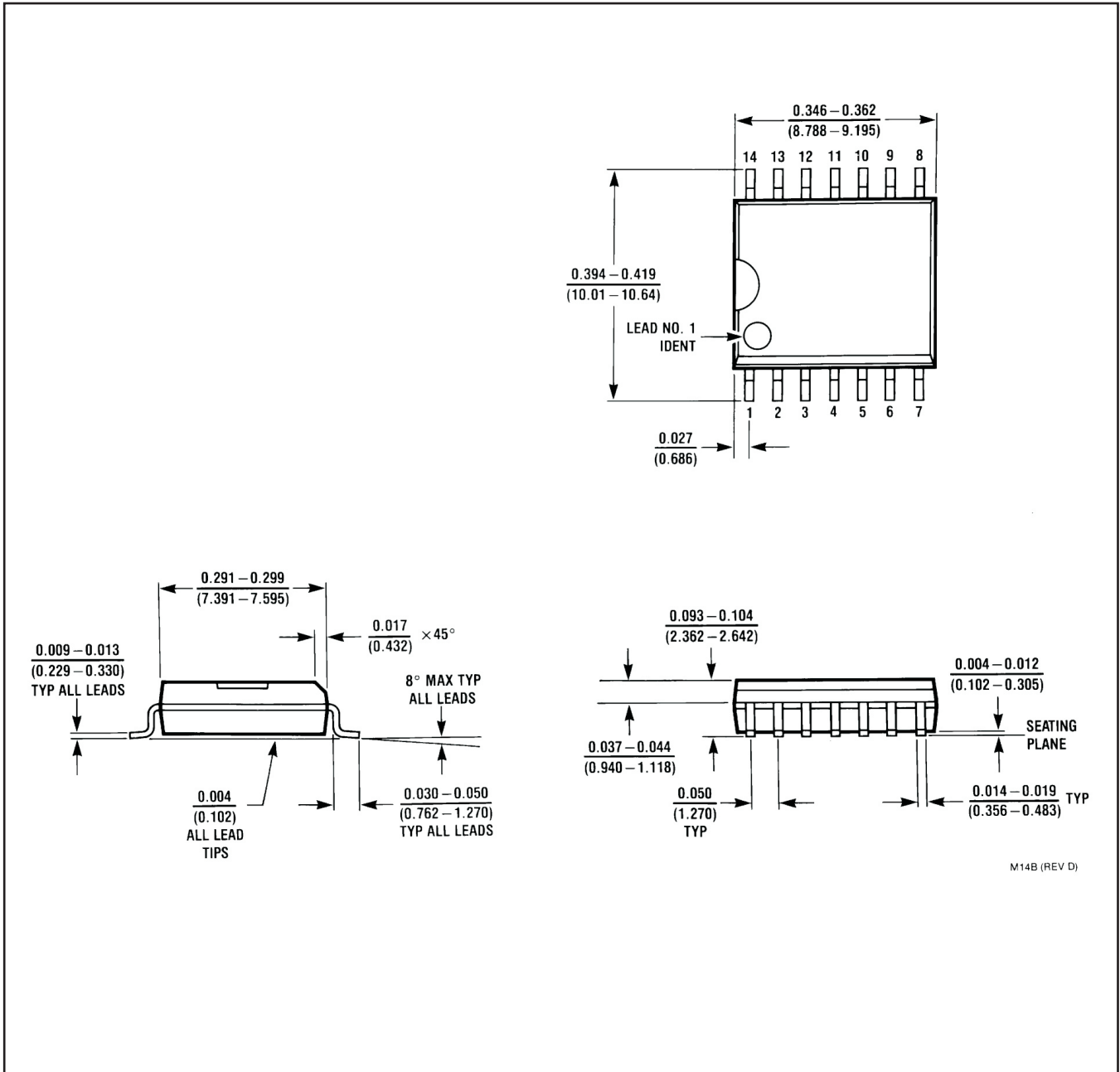

P (R-PDIP-T8)

PLASTIC DUAL-IN-LINE PACKAGE



- NOTES:
- A. All linear dimensions are in inches (millimeters).
 - B. This drawing is subject to change without notice.
 - C. Falls within JEDEC MS-001 variation BA.

IMPORTANT NOTICE AND DISCLAIMER

TI PROVIDES TECHNICAL AND RELIABILITY DATA (INCLUDING DATASHEETS), DESIGN RESOURCES (INCLUDING REFERENCE DESIGNS), APPLICATION OR OTHER DESIGN ADVICE, WEB TOOLS, SAFETY INFORMATION, AND OTHER RESOURCES "AS IS" AND WITH ALL FAULTS, AND DISCLAIMS ALL WARRANTIES, EXPRESS AND IMPLIED, INCLUDING WITHOUT LIMITATION ANY IMPLIED WARRANTIES OF MERCHANTABILITY, FITNESS FOR A PARTICULAR PURPOSE OR NON-INFRINGEMENT OF THIRD PARTY INTELLECTUAL PROPERTY RIGHTS.

These resources are intended for skilled developers designing with TI products. You are solely responsible for (1) selecting the appropriate TI products for your application, (2) designing, validating and testing your application, and (3) ensuring your application meets applicable standards, and any other safety, security, or other requirements. These resources are subject to change without notice. TI grants you permission to use these resources only for development of an application that uses the TI products described in the resource. Other reproduction and display of these resources is prohibited. No license is granted to any other TI intellectual property right or to any third party intellectual property right. TI disclaims responsibility for, and you will fully indemnify TI and its representatives against, any claims, damages, costs, losses, and liabilities arising out of your use of these resources.

TI's products are provided subject to TI's Terms of Sale (www.ti.com/legal/termsofsale.html) or other applicable terms available either on ti.com or provided in conjunction with such TI products. TI's provision of these resources does not expand or otherwise alter TI's applicable warranties or warranty disclaimers for TI products.

Mailing Address: Texas Instruments, Post Office Box 655303, Dallas, Texas 75265
Copyright © 2019, Texas Instruments Incorporated

Looking for pricing, stock, or lifecycle information?

Click below to explore more details on WIN SOURCE:

 [View LM2574M-15/NOPB on WIN SOURCE](#)

 [Texas Instruments](#) Information

Optimize Your Supply Chain with WIN SOURCE Solutions

-  Global Sourcing Solution
-  Obsolete Management
-  Cost Control Management
-  Shortage Management
-  Alternative Solution
-  Excess Inventory Management