



THE DATASHEET OF LM2831ZSDX/NOPB



LM2831 High-Frequency 1.5-A Load — Step-Down DC-DC Regulator

1 Features

- Space-Saving SOT-23 Package
- Input Voltage Range of 3 V to 5.5 V
- Output Voltage Range of 0.6 V to 4.5 V
- 1.5-A Output Current
- High Switching Frequency
 - 1.6 MHz (LM2831X)
 - 0.55 MHz (LM2831Y)
 - 3 MHz (LM2831Z)
- 130-mΩ PMOS Switch
- 0.6-V, 2% Internal Voltage Reference
- Internal Soft Start
- Current Mode, PWM Operation
- Thermal Shutdown
- Overvoltage Protection

2 Applications

- Local 5 V to Vcore Step-Down Converters
- Core Power in HDDs
- Set-Top Boxes
- USB Powered Devices
- DSL Modems

3 Description

The LM2831 regulator is a monolithic, high-frequency, PWM step-down DC-DC converter in a 5-pin SOT-23 and a 6-Pin WSON package. The LM2831 provides all the active functions to provide local DC-DC conversion with fast transient response and accurate regulation in the smallest possible PCB area. With a minimum of external components, the LM2831 is easy to use. The ability to drive 1.5-A loads with an internal 130-mΩ PMOS switch using state-of-the-art 0.5-μm BiCMOS technology results in the best power density available. The world-class control circuitry allows on-times as low as 30 ns, thus supporting exceptionally high frequency conversion over the entire 3 V to 5.5 V input operating range, down to the minimum output voltage of 0.6 V. Switching frequency is internally set to 550 kHz, 1.6 MHz, or 3 MHz, allowing the use of extremely small surface mount inductors and chip capacitors. Even though the operating frequency is high, efficiencies of up to 93% are easy to achieve. External shutdown is included, featuring an ultra-low standby current of 30 nA. The LM2831 utilizes current-mode control and internal compensation to provide high-performance regulation over a wide range of operating conditions. Additional features include internal soft-start circuitry to reduce inrush current, pulse-by-pulse current limit, thermal shutdown, and output overvoltage protection.

Device Information⁽¹⁾

PART NUMBER	PACKAGE	BODY SIZE (NOM)
LM2831	WSON (6)	3.00 mm × 3.00 mm
	SOT-23 (5)	1.60 mm × 2.90 mm

(1) For all available packages, see the orderable addendum at the end of the data sheet.

Typical Application Circuit

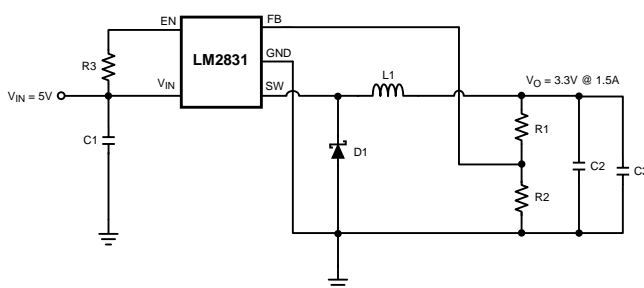

Efficiency vs Load

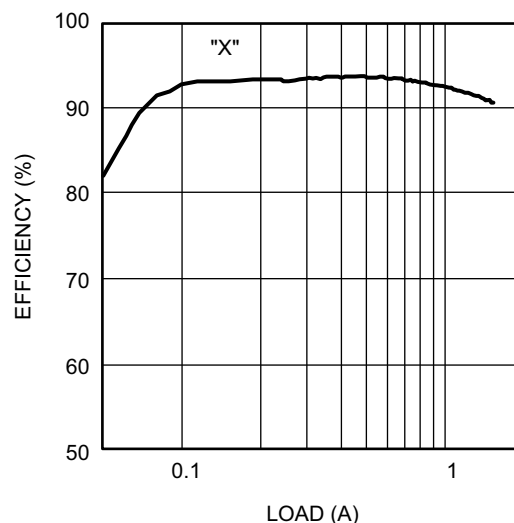

Table of Contents

1 Features 1 2 Applications 1 3 Description 1 4 Revision History 2 5 Pin Configuration and Functions 3 6 Specifications 4 6.1 Absolute Maximum Ratings 4 6.2 ESD Ratings 4 6.3 Recommended Operating Conditions 4 6.4 Thermal Information 4 6.5 Electrical Characteristics 5 6.6 Typical Characteristics 6 7 Detailed Description 9 7.1 Overview 9 7.2 Functional Block Diagram 9 7.3 Feature Description 9	7.4 Device Functional Modes 11 8 Application and Implementation 12 8.1 Application Information 12 8.2 Typical Applications 12 9 Power Supply Recommendations 25 10 Layout 25 10.1 Layout Guidelines 25 10.2 Layout Example 29 11 Device and Documentation Support 30 11.1 Device Support 30 11.2 Documentation Support 30 11.3 Community Resources 30 11.4 Trademarks 30 11.5 Electrostatic Discharge Caution 30 11.6 Glossary 30 12 Mechanical, Packaging, and Orderable Information 30
---	--

4 Revision History

NOTE: Page numbers for previous revisions may differ from page numbers in the current version.

Changes from Revision C (April 2013) to Revision D	Page
<ul style="list-style-type: none"> • Added <i>ESD Ratings</i> table, <i>Feature Description</i> section, <i>Device Functional Modes</i>, <i>Application and Implementation</i> section, <i>Power Supply Recommendations</i> section, <i>Layout</i> section, <i>Device and Documentation Support</i> section, and <i>Mechanical, Packaging, and Orderable Information</i> section. 	1

Changes from Revision B (April 2013) to Revision C	Page
<ul style="list-style-type: none"> • Changed layout of National Data Sheet to TI format 	24

5 Pin Configuration and Functions

**NGG Package
6-Pins WSON
Top View**

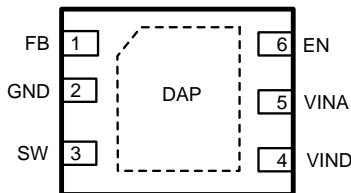

**DBV Package
5-Pin SOT-23
Top View**

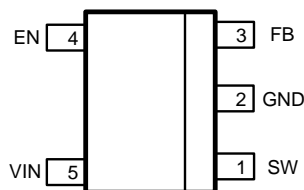

Pin Functions

NAME	PIN		I/O	DESCRIPTION
	SOT-23	WSON		
EN	4	6	I	Enable control input. Logic high enables operation. Do not allow this pin to float or be greater than $V_{IN} + 0.3\text{ V}$, or $V_{INA} + 0.3\text{ V}$ for WSON.
FB	3	1	I	Feedback pin. Connect to external resistor divider to set output voltage.
GND	2	2	PWR	Signal and power ground pin. Place the bottom resistor of the feedback network as close as possible to this pin.
SW	1	3	O	Output switch. Connect to the inductor and catch diode.
VIN	5	—	PWR	Input supply voltage
VINA	—	5	PWR	Control circuitry supply voltage. Connect VINA to VIND on PC board.
VIND	—	4	PWR	Power input supply
Die Attach Pad	—	DAP	PWR	Connect to system ground for low thermal impedance, but it cannot be used as a primary GND connection.

6 Specifications

6.1 Absolute Maximum Ratings

over operating free-air temperature range (unless otherwise noted)⁽¹⁾⁽²⁾

	MIN	MAX	UNIT	
V _{IN}	-0.5	7	V	
FB Voltage	-0.5	3	V	
EN Voltage	-0.5	7	V	
SW Voltage	-0.5	7	V	
Junction Temperature ⁽³⁾		150	°C	
Soldering Information	Infrared or Convection Reflow (15 sec)		220	°C
Storage Temperature, T _{stg}	-65	150	°C	

- (1) Stresses beyond those listed under *Absolute Maximum Ratings* may cause permanent damage to the device. These are stress ratings only, which do not imply functional operation of the device at these or any other conditions beyond those indicated under *Recommended Operating Conditions*. Exposure to absolute-maximum-rated conditions for extended periods may affect device reliability.
- (2) If Military/Aerospace specified devices are required, please contact the Texas Instruments Sales Office/ Distributors for availability and specifications.
- (3) Thermal shutdown will occur if the junction temperature exceeds the maximum junction temperature of the device.

6.2 ESD Ratings

	VALUE	UNIT	
V _(ESD) Electrostatic discharge	Human body model (HBM), per ANSI/ESDA/JEDEC JS-001 ⁽¹⁾	±2000	V

- (1) JEDEC document JEP155 states that 500-V HBM allows safe manufacturing with a standard ESD control process.

6.3 Recommended Operating Conditions

over operating free-air temperature range (unless otherwise noted)

	MIN	NOM	MAX	UNIT
V _{IN}	3		5.5	V
Junction Temperature	-40		125	°C

6.4 Thermal Information

THERMAL METRIC ⁽¹⁾	LM2831		UNIT
	SOT-23 (DBV)	WSON (NGG)	
	5 PINS	6 PINS	
R _{θJA} Junction-to-ambient thermal resistance ⁽²⁾	163.4	54.9	°C/W
R _{θJC(top)} Junction-to-case (top) thermal resistance ⁽²⁾	114.4	50.8	°C/W
R _{θJB} Junction-to-board thermal resistance	26.8	29.2	°C/W
Ψ _{JT} Junction-to-top characterization parameter	12.4	0.6	°C/W
Ψ _{JB} Junction-to-board characterization parameter	26.2	29.3	°C/W
R _{θJC(bot)} Junction-to-case (bottom) thermal resistance	N/A	9.2	°C/W

- (1) For more information about traditional and new thermal metrics, see the *Semiconductor and IC Package Thermal Metrics* application report, [SPRA953](#).
- (2) Applies for packages soldered directly onto a 3" x 3" PC board with 2 oz. copper on 4 layers in still air.

6.5 Electrical Characteristics

$V_{IN} = 5\text{ V}$ unless otherwise indicated under the *Test Conditions* column. Limits are for $T_J = 25^\circ\text{C}$. Minimum and Maximum limits are specified through test, design, or statistical correlation. Typical values represent the most likely parametric norm at $T_J = 25^\circ\text{C}$, and are provided for reference purposes only.

PARAMETER		TEST CONDITIONS		MIN	TYP	MAX	UNIT
V_{FB}	Feedback Voltage	WSON and SOT-23 Package	$T_J = 25^\circ\text{C}$	0.600		0.612	V
			-40°C to 125°C	0.588			
$\Delta V_{FB}/V_{IN}$	Feedback Voltage Line Regulation	$V_{IN} = 3\text{ V}$ to 5 V		0.02			%/V
I_B	Feedback Input Bias Current		$T_J = 25^\circ\text{C}$	0.1		100	nA
			-40°C to 125°C				
UVLO	Undervoltage Lockout	V_{IN} Rising	$T_J = 25^\circ\text{C}$	2.73		2.90	V
			-40°C to 125°C				
		V_{IN} Falling	$T_J = 25^\circ\text{C}$	2.3		1.85	V
			-40°C to 125°C				
UVLO Hysteresis				0.43			V
F_{SW}	Switching Frequency	LM2831-X	$T_J = 25^\circ\text{C}$	1.6		1.95	MHz
			-40°C to 125°C	1.2			
		LM2831-Y	$T_J = 25^\circ\text{C}$	0.55		0.7	
			-40°C to 125°C	0.4			
		LM2831-Z	$T_J = 25^\circ\text{C}$	3		3.75	
			-40°C to 125°C	2.25			
D_{MAX}	Maximum Duty Cycle	LM2831-X	$T_J = 25^\circ\text{C}$	94%		86%	
			-40°C to 125°C				
		LM2831-Y	$T_J = 25^\circ\text{C}$	96%		90%	
			-40°C to 125°C				
		LM2831-Z	$T_J = 25^\circ\text{C}$	90%		82%	
			-40°C to 125°C				
D_{MIN}	Minimum Duty Cycle	LM2831-X	5%		7%		
		LM2831-Y	2%				
		LM2831-Z					
$R_{DS(ON)}$	Switch On Resistance	WSON Package		150		m Ω	
		SOT-23 Package	$T_J = 25^\circ\text{C}$	130			
			-40°C to 125°C	195			
I_{CL}	Switch Current Limit	$V_{IN} = 3.3\text{ V}$	$T_J = 25^\circ\text{C}$	2.5		A	
			-40°C to 125°C	1.8			
V_{EN_TH}	Shutdown Threshold Voltage			0.4		V	
	Enable Threshold Voltage			1.8			
I_{SW}	Switch Leakage			100		nA	
I_{EN}	Enable Pin Current	Sink/Source		100		nA	
I_Q	Quiescent Current (switching)	LM2831X $V_{FB} = 0.55$	$T_J = 25^\circ\text{C}$	3.3		5	
			-40°C to 125°C				
		LM2831Y $V_{FB} = 0.55$	$T_J = 25^\circ\text{C}$	2.8		4.5	
			-40°C to 125°C				
	LM2831Z $V_{FB} = 0.55$	$T_J = 25^\circ\text{C}$	4.3		6.5		
		-40°C to 125°C					
Quiescent Current (shutdown)		All Options $V_{EN} = 0\text{ V}$		30		nA	
T_{SD}	Thermal Shutdown Temperature			165		$^\circ\text{C}$	

6.6 Typical Characteristics

All curves taken at $V_{IN} = 5\text{ V}$ with configuration in typical application circuit shown in *Application Information* section of this datasheet. $T_J = 25^\circ\text{C}$, unless otherwise specified.

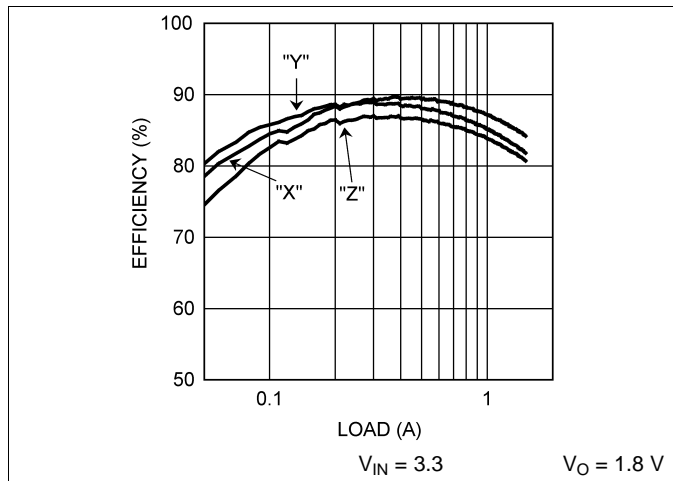

Figure 1. η vs Load – X, Y, and Z Options

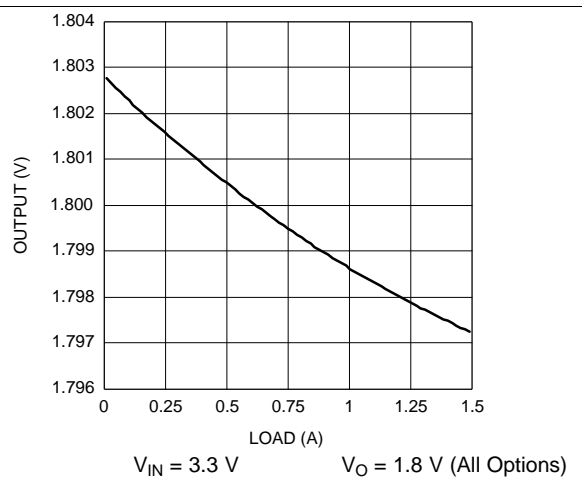

Figure 2. Load Regulation

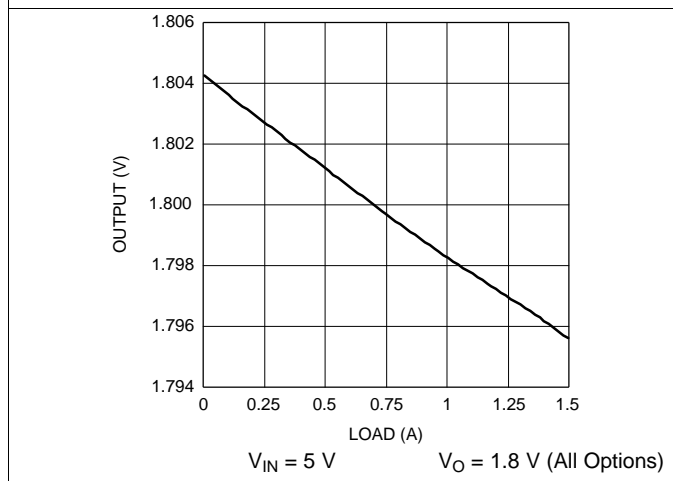

Figure 3. Load Regulation

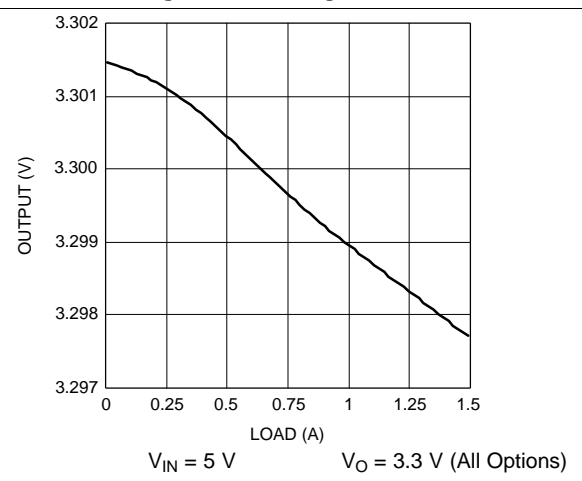

Figure 4. Load Regulation

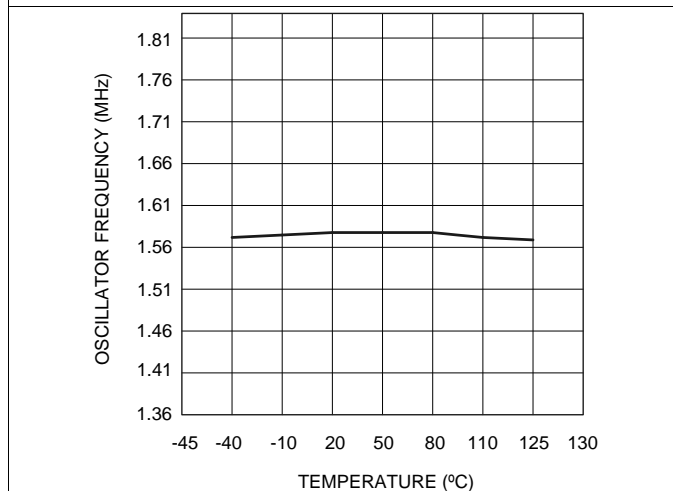

Figure 5. Oscillator Frequency vs Temperature – X Option

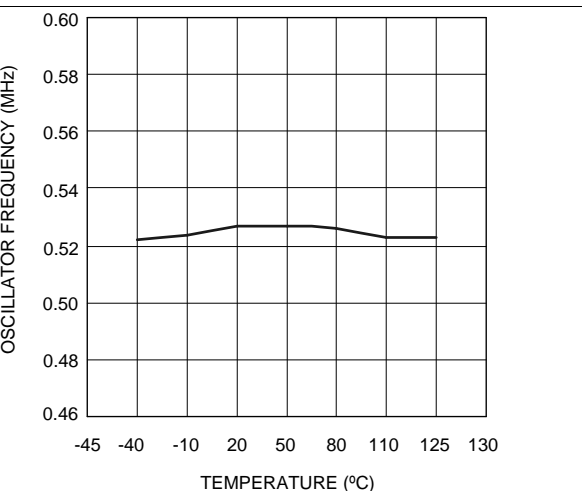

Figure 6. Oscillator Frequency vs Temperature – Y Option

Typical Characteristics (continued)

All curves taken at $V_{IN} = 5\text{ V}$ with configuration in typical application circuit shown in [Application Information](#) section of this datasheet. $T_J = 25^\circ\text{C}$, unless otherwise specified.

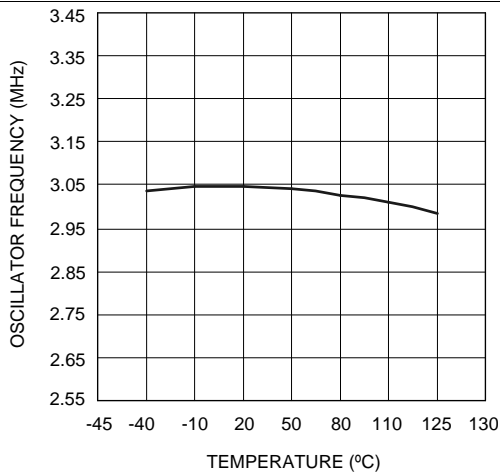

Figure 7. Oscillator Frequency vs Temperature – Z Option

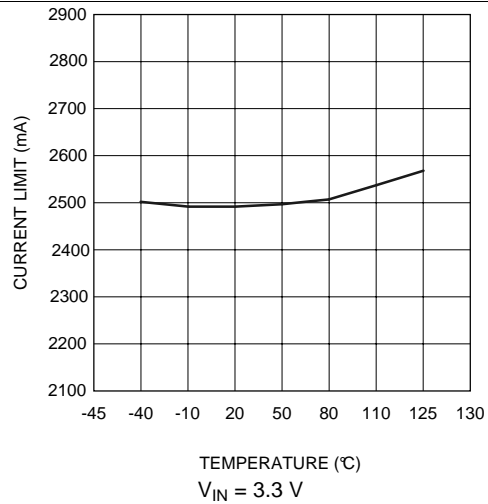

Figure 8. Current Limit vs Temperature

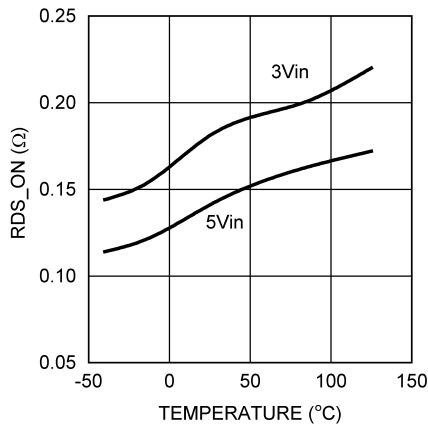

Figure 9. RDSON vs Temperature (WSON Package)

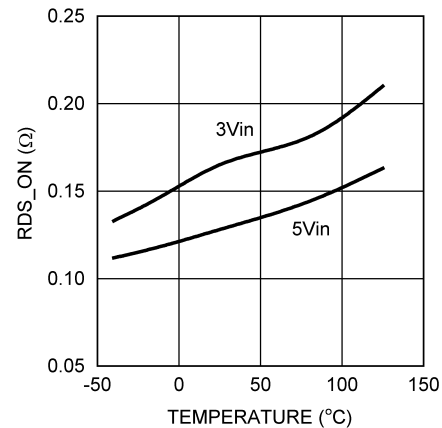

Figure 10. RDSON vs Temperature (SOT-23 Package)

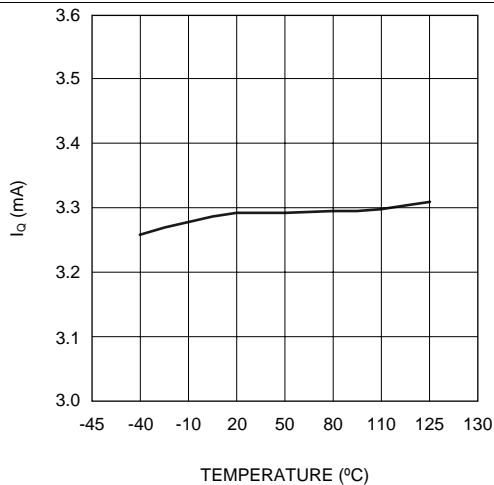

Figure 11. LM2831X I_Q (Quiescent Current)

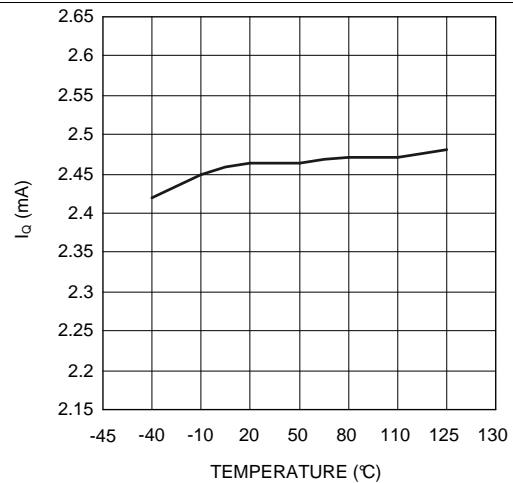
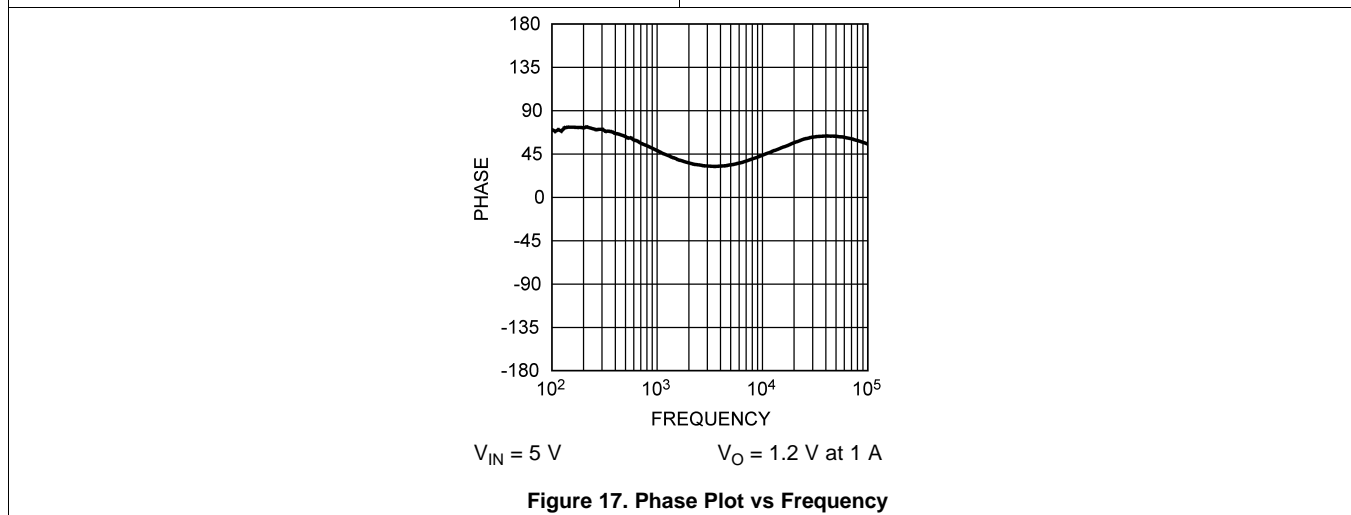
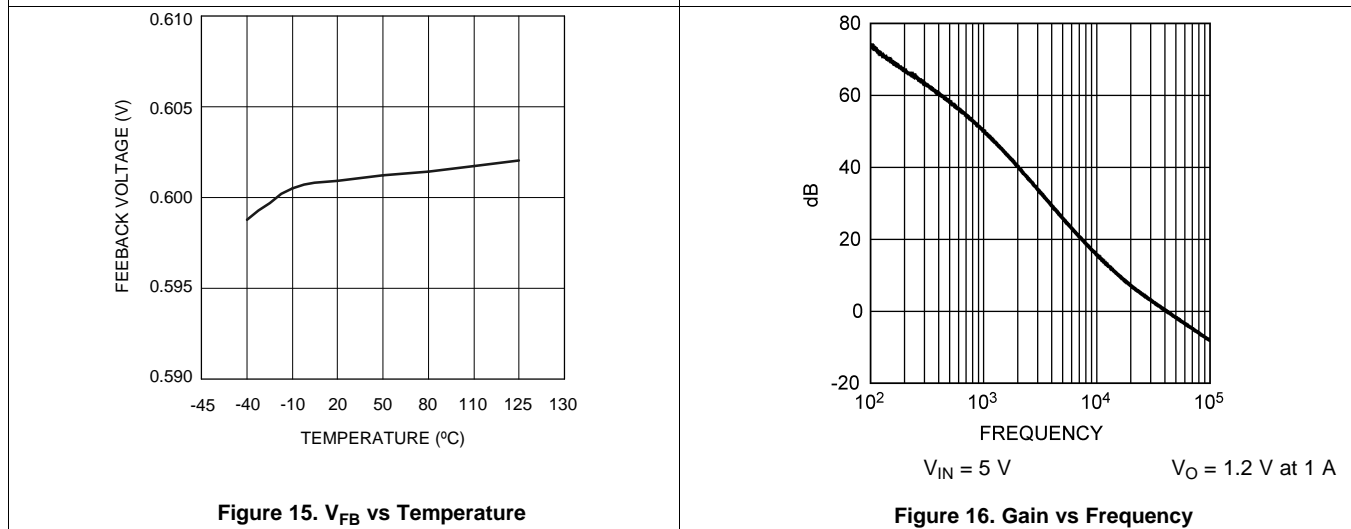
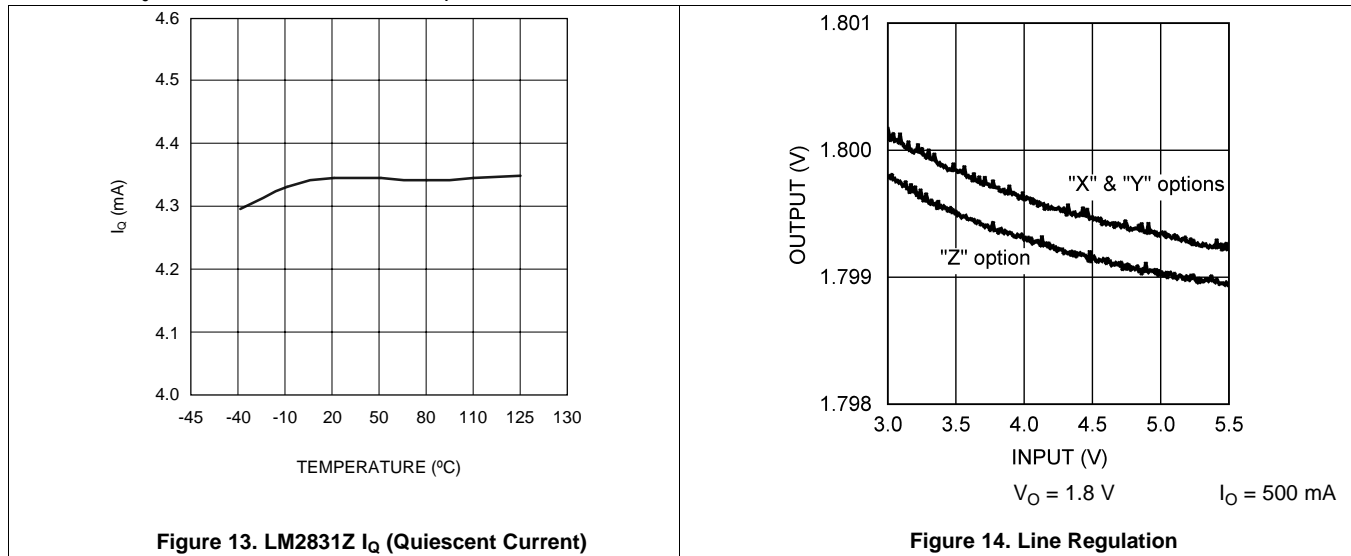

Figure 12. LM2831Y I_Q (Quiescent Current)

Typical Characteristics (continued)

All curves taken at $V_{IN} = 5\text{ V}$ with configuration in typical application circuit shown in [Application Information](#) section of this datasheet. $T_J = 25^\circ\text{C}$, unless otherwise specified.



7 Detailed Description

7.1 Overview

The LM2831 device is a constant-frequency PWM buck regulator IC that delivers a 1.5-A load current. The regulator has a preset switching frequency of 550 kHz, 1.6 MHz, or 3 MHz. This high-frequency allows the LM2831 to operate with small surface mount capacitors and inductors, resulting in a DC-DC converter that requires a minimum amount of board space. The LM2831 is internally compensated, so the device is simple to use and requires few external components.

7.2 Functional Block Diagram

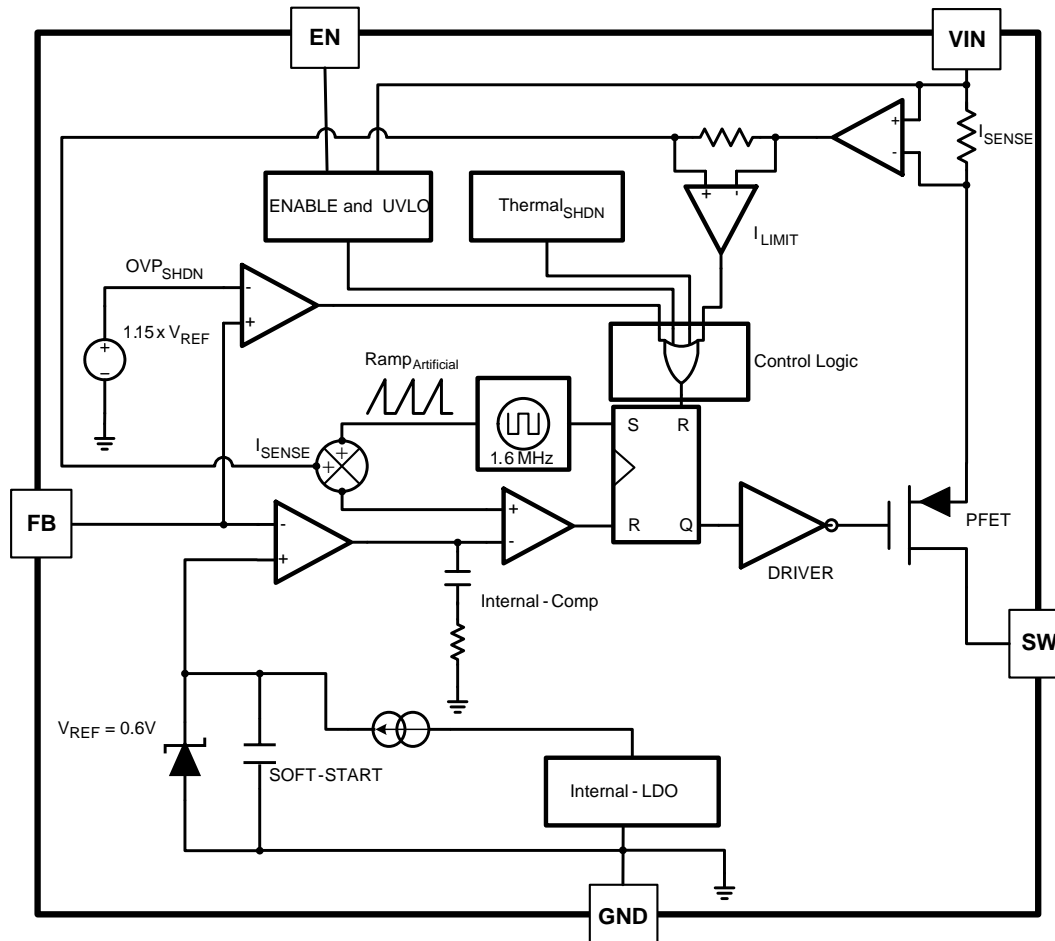

7.3 Feature Description

7.3.1 Theory of Operation

The LM2831 uses current-mode control to regulate the output voltage. The following operating description of the LM2831 will refer to [Functional Block Diagram](#) and to the waveforms in [Figure 18](#). The LM2831 supplies a regulated output voltage by switching the internal PMOS control switch at constant-frequency and variable duty cycle. A switching cycle begins at the falling edge of the reset pulse generated by the internal oscillator. When this pulse goes low, the output control logic turns on the internal PMOS control switch. During this on-time, the SW pin voltage (V_{SW}) swings up to approximately V_{IN} , and the inductor current (I_L) increases with a linear slope. I_L is measured by the current sense amplifier, which generates an output proportional to the switch current. The sense signal is summed with the regulator's corrective ramp and compared to the error amplifier's output, which

Feature Description (continued)

is proportional to the difference between the feedback voltage and V_{REF} . When the PWM comparator output goes high, the output switch turns off until the next switching cycle begins. During the switch off-time, inductor current discharges through the Schottky catch diode, which forces the SW pin to swing below ground by the forward voltage (V_D) of the Schottky catch diode. The regulator loop adjusts the duty cycle (D) to maintain a constant output voltage.

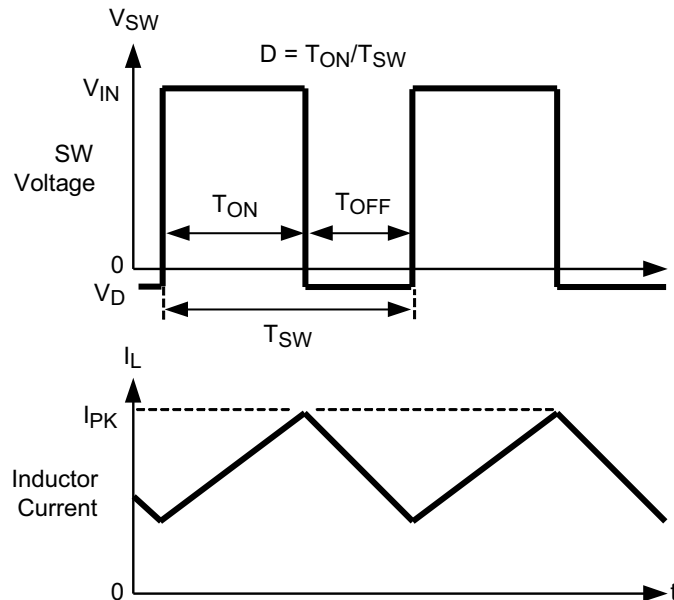

Figure 18. Typical Waveforms

7.3.2 Soft Start

This function forces V_{OUT} to increase at a controlled rate during start up. During soft start, the error amplifier's reference voltage ramps from 0 V to its nominal value of 0.6 V in approximately 600 μ s. This forces the regulator output to ramp up in a controlled fashion, which helps reduce inrush current.

7.3.3 Output Overvoltage Protection

The overvoltage comparator compares the FB pin voltage to a voltage that is 15% higher than the internal reference V_{REF} . Once the FB pin voltage goes 15% above the internal reference, the internal PMOS control switch is turned off, which allows the output voltage to decrease toward regulation.

7.3.4 Undervoltage Lockout

Undervoltage lockout (UVLO) prevents the LM2831 from operating until the input voltage exceeds 2.73 V (typical). The UVLO threshold has approximately 430 mV of hysteresis, so the part will operate until V_{IN} drops below 2.3 V (typical). Hysteresis prevents the part from turning off during power up if V_{IN} is non-monotonic.

7.3.5 Current Limit

The LM2831 uses cycle-by-cycle current limiting to protect the output switch. During each switching cycle, a current limit comparator detects if the output switch current exceeds 2.5 A (typical), and turns off the switch until the next switching cycle begins.

7.3.6 Thermal Shutdown

Thermal shutdown limits total power dissipation by turning off the output switch when the IC junction temperature exceeds 165°C. After thermal shutdown occurs, the output switch doesn't turn on until the junction temperature drops to approximately 150°C.

7.4 Device Functional Modes

The LM2831 has an enable pin (EN) control Input. A logic high enables device operation. Do not float this pin or let this pin be greater than $V_{IN} + 0.3\text{ V}$ for the SOT package option, or $V_{INA} + 0.3\text{ V}$ for the WSON package option.

8 Application and Implementation

NOTE

Information in the following applications sections is not part of the TI component specification, and TI does not warrant its accuracy or completeness. TI's customers are responsible for determining suitability of components for their purposes. Customers should validate and test their design implementation to confirm system functionality.

8.1 Application Information

The LM2831 device will operate with input voltage range from 3 V to 5.5 V and provide a regulated output voltage. This device is optimized for high-efficiency operation with minimum number of external components. For component selection, see [Detailed Design Procedure](#).

8.2 Typical Applications

8.2.1 LM2831X Design Example 1

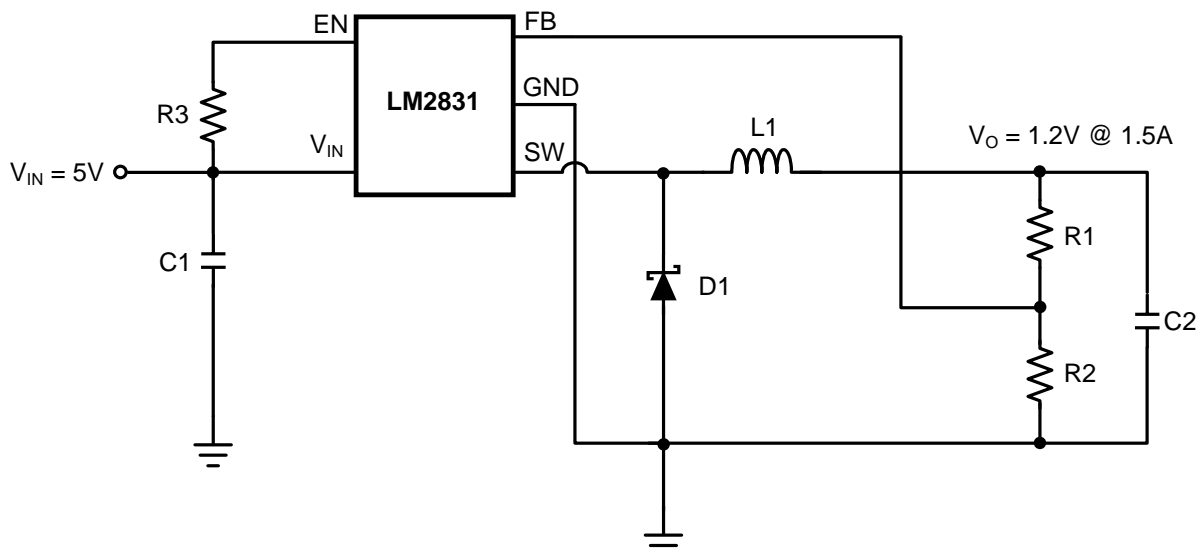

Figure 19. LM2831X (1.6 MHz): $V_{IN} = 5\text{ V}$, $V_O = 1.2\text{ V}$ at 1.5 A

8.2.1.1 Design Requirements

The device must be able to operate at any voltage within the recommended operating range. Load current must be defined to properly size the inductor, input, and output capacitors. Inductor should be able to handle full expected load current as well as the peak current generated during load transients and start up. Inrush current at start-up will depend on the output capacitor selection. More details are provided in [Detailed Design Procedure](#).

Typical Applications (continued)

8.2.1.2 Detailed Design Procedure

Table 1. Bill of Materials

PART ID	PART VALUE	MANUFACTURER	PART NUMBER
U1	1.5-A Buck Regulator	TI	LM2831X
C1, Input Cap	22 μ F, 6.3 V, X5R	TDK	C3216X5ROJ226M
C2, Output Cap	2x22 μ F, 6.3 V, X5R	TDK	C3216X5ROJ226M
D1, Catch Diode	0.3 V _f Schottky 1.5 A, 30 V _R	TOSHIBA	CRS08
L1	3.3 μ H, 2.2 A	TDK	VLCF5020T-3R3N2R0-1
R2	15.0 k Ω , 1%	Vishay	CRCW08051502F
R1	15.0 k Ω , 1%	Vishay	CRCW08051502F
R3	100 k Ω , 1%	Vishay	CRCW08051003F

8.2.1.2.1 Inductor Selection

The duty cycle (D) can be approximated quickly using the ratio of output voltage (V_O) to input voltage (V_{IN}):

$$D = \frac{V_{OUT}}{V_{IN}} \quad (1)$$

The catch diode (D1) forward voltage drop and the voltage drop across the internal PMOS must be included to calculate a more accurate duty cycle. Calculate D by using the following formula:

$$D = \frac{V_{OUT} + V_D}{V_{IN} + V_D - V_{SW}} \quad (2)$$

V_{SW} can be approximated by:

$$V_{SW} = I_{OUT} \times R_{DSON} \quad (3)$$

The diode forward drop (V_D) can range from 0.3 V to 0.7 V depending on the quality of the diode. The lower the V_D, the higher the operating efficiency of the converter. The inductor value determines the output ripple current. Lower inductor values decrease the size of the inductor, but increase the output ripple current. An increase in the inductor value will decrease the output ripple current.

One must ensure that the minimum current limit (1.8 A) is not exceeded, so the peak current in the inductor must be calculated. The peak current (I_{LPK}) in the inductor is calculated by:

$$I_{LPK} = I_{OUT} + \Delta i_L \quad (4)$$

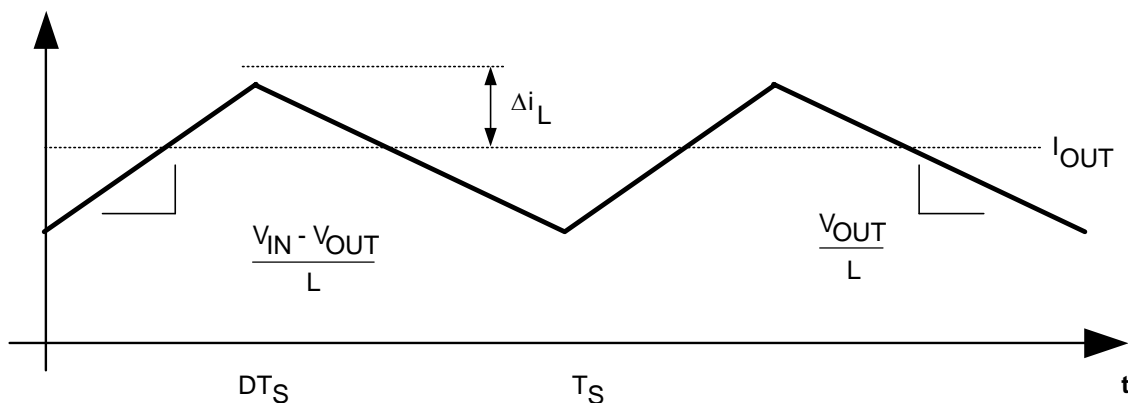
Figure 20. Inductor Current

$$\frac{V_{IN} - V_{OUT}}{L} = \frac{2\Delta i_L}{DT_S} \quad (5)$$

In general,

$$\Delta i_L = 0.1 \times (I_{OUT}) \rightarrow 0.2 \times (I_{OUT}) \quad (6)$$

If $\Delta i_L = 20\%$ of 1.50 A, the peak current in the inductor will be 1.8 A. The minimum ensured current limit over all operating conditions is 1.8 A. One can either reduce Δi_L , or make the engineering judgment that zero margin will be safe enough. The typical current limit is 2.5 A.

The LM2831 operates at frequencies allowing the use of ceramic output capacitors without compromising transient response. Ceramic capacitors allow higher inductor ripple without significantly increasing output ripple. See the [Output Capacitor](#) section for more details on calculating output voltage ripple. Now that the ripple current is determined, the inductance is calculated by:

$$L = \left(\frac{DT_S}{2\Delta i_L} \right) \times V_{IN} - V_{OUT} \quad (7)$$

Where:

$$T_S = \frac{1}{f_S} \quad (8)$$

When selecting an inductor, make sure that it is capable of supporting the peak output current without saturating. Inductor saturation will result in a sudden reduction in inductance and prevent the regulator from operating correctly. Because of the speed of the internal current limit, the peak current of the inductor need only be specified for the required maximum output current. For example, if the designed maximum output current is 1 A and the peak current is 1.25 A, then the inductor should be specified with a saturation current limit of > 1.25 A. There is no need to specify the saturation or peak current of the inductor at the 2.5-A typical switch current limit. The difference in inductor size is a factor of 5. Because of the operating frequency of the LM2831, ferrite based inductors are preferred to minimize core losses. This presents little restriction since the variety of ferrite-based inductors is huge. Lastly, inductors with lower series resistance (R_{DCR}) will provide better operating efficiency. For recommended inductors, see [LM2831X Design Example 2](#) through [LM2831X Buck Converter and Voltage Double Circuit With LDO Follower Design Example 9](#).

8.2.1.2.2 Input Capacitor

An input capacitor is necessary to ensure that V_{IN} does not drop excessively during switching transients. The primary specifications of the input capacitor are capacitance, voltage, RMS current rating, and ESL (Equivalent Series Inductance). The recommended input capacitance is 22 μ F. The input voltage rating is specifically stated by the capacitor manufacturer. Make sure to check any recommended deratings and also verify if there is any significant change in capacitance at the operating input voltage and the operating temperature. The input capacitor maximum RMS input current rating (I_{RMS_IN}) must be greater than:

$$I_{RMS_IN} \sqrt{D \left[I_{OUT}^2 (1-D) + \frac{\Delta i^2}{3} \right]} \quad (9)$$

Neglecting inductor ripple simplifies the above equation to:

$$I_{RMS_IN} = I_{OUT} \times \sqrt{D(1-D)} \quad (10)$$

It can be shown from the above equation that maximum RMS capacitor current occurs when $D = 0.5$. Always calculate the RMS at the point where the duty cycle D is closest to 0.5. The ESL of an input capacitor is usually determined by the effective cross sectional area of the current path. A large leaded capacitor will have high ESL and a 0805 ceramic chip capacitor will have very low ESL. At the operating frequencies of the LM2831, leaded capacitors may have an ESL so large that the resulting impedance ($2\pi fL$) will be higher than that required to provide stable operation. As a result, surface mount capacitors are strongly recommended.

Sanyo POSCAP, Tantalum or Niobium, Panasonic SP, and multilayer ceramic capacitors (MLCC) are all good choices for both input and output capacitors and have very low ESL. For MLCCs it is recommended to use X7R or X5R type capacitors due to their tolerance and temperature characteristics. Consult capacitor manufacturer data sheets to see how rated capacitance varies over operating conditions.

8.2.1.2.3 Output Capacitor

The output capacitor is selected based upon the desired output ripple and transient response. The initial current of a load transient is provided mainly by the output capacitor. The output ripple of the converter is:

$$V_{\text{OUT}} = \Delta I_L \left(R_{\text{ESR}} + \frac{1}{8 \times F_{\text{SW}} \times C_{\text{OUT}}} \right) \quad (11)$$

When using MLCCs, the ESR is typically so low that the capacitive ripple may dominate. When this occurs, the output ripple will be approximately sinusoidal and 90° phase shifted from the switching action. Given the availability and quality of MLCCs and the expected output voltage of designs using the LM2831, there is really no need to review any other capacitor technologies. Another benefit of ceramic capacitors is their ability to bypass high frequency noise. A certain amount of switching edge noise will couple through parasitic capacitances in the inductor to the output. A ceramic capacitor will bypass this noise while a tantalum will not. Since the output capacitor is one of the two external components that control the stability of the regulator control loop, most applications will require a minimum of 22 µF of output capacitance. Capacitance often, but not always, can be increased significantly with little detriment to the regulator stability. Like the input capacitor, recommended multilayer ceramic capacitors are X7R or X5R types.

8.2.1.2.4 Catch Diode

The catch diode (D1) conducts during the switch off-time. A Schottky diode is recommended for its fast switching times and low forward voltage drop. The catch diode should be chosen so that its current rating is greater than:

$$I_{D1} = I_{\text{OUT}} \times (1-D) \quad (12)$$

The reverse breakdown rating of the diode must be at least the maximum input voltage plus appropriate margin. To improve efficiency, choose a Schottky diode with a low forward voltage drop.

8.2.1.2.5 Output Voltage

The output voltage is set using the following equation where R2 is connected between the FB pin and GND, and R1 is connected between V_O and the FB pin. A good value for R2 is 10 kΩ. When designing a unity gain converter (V_O = 0.6 V), R1 should be from 0 Ω to 100 Ω, and R2 should be equal or greater than 10 kΩ.

$$R1 = \left(\frac{V_{\text{OUT}}}{V_{\text{REF}}} - 1 \right) \times R2 \quad (13)$$

$$V_{\text{REF}} = 0.60 \text{ V} \quad (14)$$

8.2.1.3 Application Curves

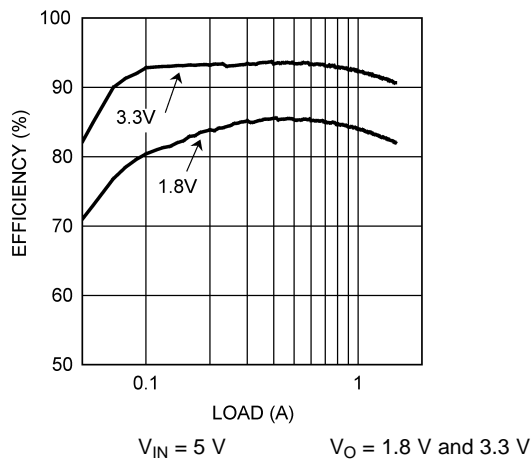
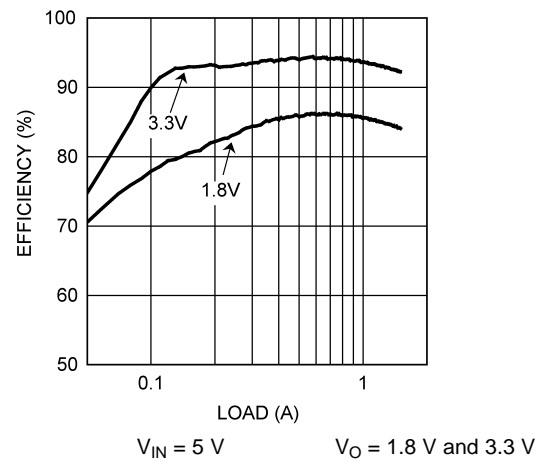
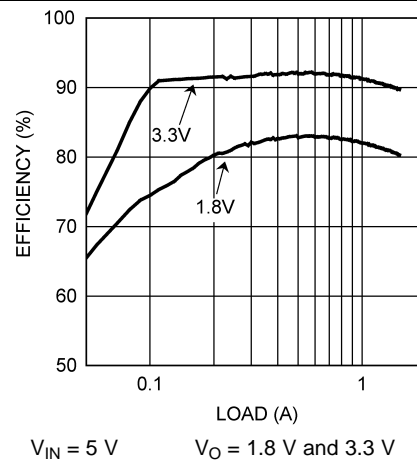
 See [Typical Characteristics](#).

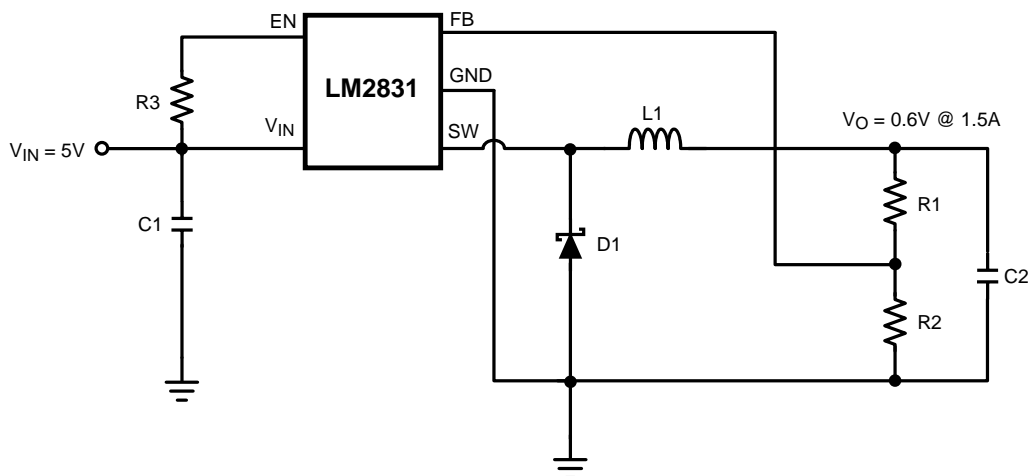
Figure 21. η vs Load – X Option

Figure 22. η vs Load – Y Option

Figure 23. η vs Load – Z Option

8.2.2 LM2831X Design Example 2

Figure 24. LM2831X (1.6 MHz): $V_{IN} = 5\text{ V}$, $V_O = 0.6\text{ V}$ at 1.5 A
Table 2. Bill of Materials

PART ID	PART VALUE	MANUFACTURER	PART NUMBER
U1	1.5-A Buck Regulator	TI	LM2831X
C1, Input Capacitor	22 μF , 6.3 V, X5R	TDK	C3216X5ROJ226M
C2, Output Capacitor	2x22 μF , 6.3 V, X5R	TDK	C3216X5ROJ226M
D1, Catch Diode	0.3 V_f Schottky 1.5 A, 30 V_R	TOSHIBA	CRS08
L1	3.3 μH , 2.2 A	TDK	VLCF5020T- 3R3N2R0-1
R2	10.0 k Ω , 1%	Vishay	CRCW08051000F
R1	0 Ω		
R3	100 k Ω , 1%	Vishay	CRCW08051003F

LM2831

SNVS422D – AUGUST 2006 – REVISED SEPTEMBER 2015

www.ti.com

8.2.3 LM2831X Design Example 3

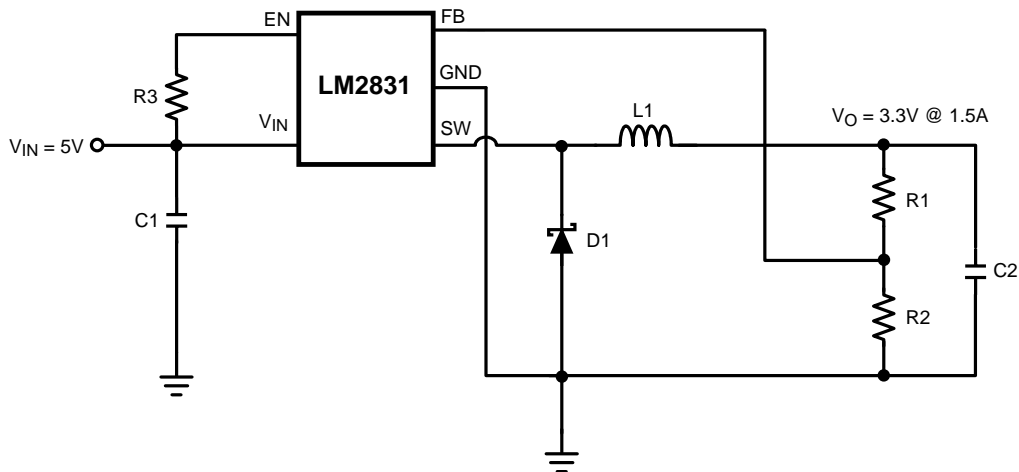
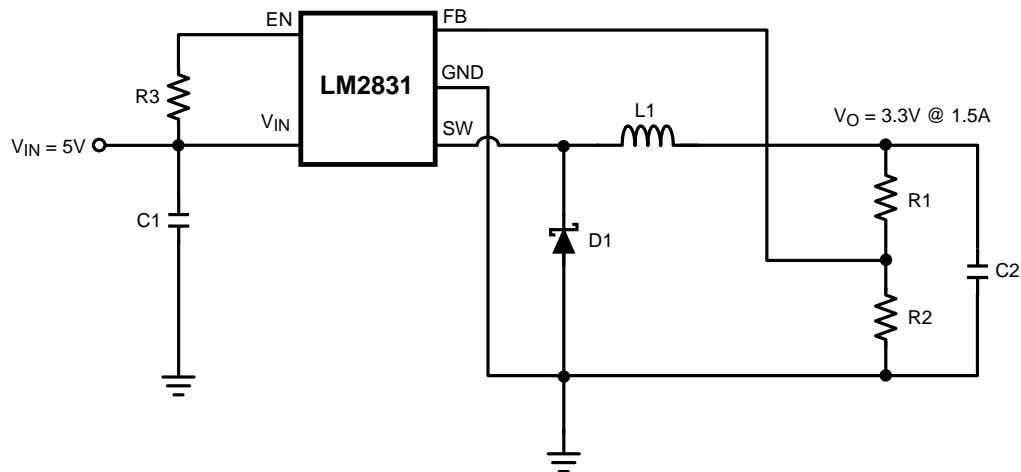

Figure 25. LM2831X (1.6 MHz): $V_{IN} = 5\text{ V}$, $V_O = 3.3\text{ V}$ at 1.5 A

Table 3. Bill of Materials

PART ID	PART VALUE	MANUFACTURER	PART NUMBER
U1	1.5-A Buck Regulator	TI	LM2831X
C1, Input Cap	22 μF , 6.3 V, X5R	TDK	C3216X5ROJ226M
C2, Output Cap	2x22 μF , 6.3 V, X5R	TDK	C3216X5ROJ226M
D1, Catch Diode	0.3 V_f Schottky 1.5 A, 30 V_R	TOSHIBA	CRS08
L1	2.7 μH 2.3 A	TDK	VLCF5020T-2R7N2R2-1
R2	10.0 $\text{k}\Omega$, 1%	Vishay	CRCW08051002F
R1	45.3 $\text{k}\Omega$, 1%	Vishay	CRCW08054532F
R3	100 $\text{k}\Omega$, 1%	Vishay	CRCW08051003F

8.2.4 LM2831Y Design Example 4

Figure 26. LM2831Y (550 kHz): $V_{IN} = 5\text{ V}$, $V_{OUT} = 3.3\text{ V}$ at 1.5 A
Table 4. Bill of Materials

PART ID	PART VALUE	MANUFACTURER	PART NUMBER
U1	1.5-A Buck Regulator	TI	LM2831Y
C1, Input Cap	22 μF , 6.3 V, X5R	TDK	C3216X5ROJ226M
C2, Output Cap	2x22 μF , 6.3 V, X5R	TDK	C3216X5ROJ226M
D1, Catch Diode	0.3 V_f Schottky 1.5 A, 30 V_R	TOSHIBA	CRS08
L1	4.7 μH 2.1 A	TDK	SLF7045T-4R7M2R0-PF
R1	45.3 $\text{k}\Omega$, 1%	Vishay	CRCW080545K3FKEA
R2	10.0 $\text{k}\Omega$, 1%	Vishay	CRCW08051002F

8.2.5 LM2831Y Design Example 5

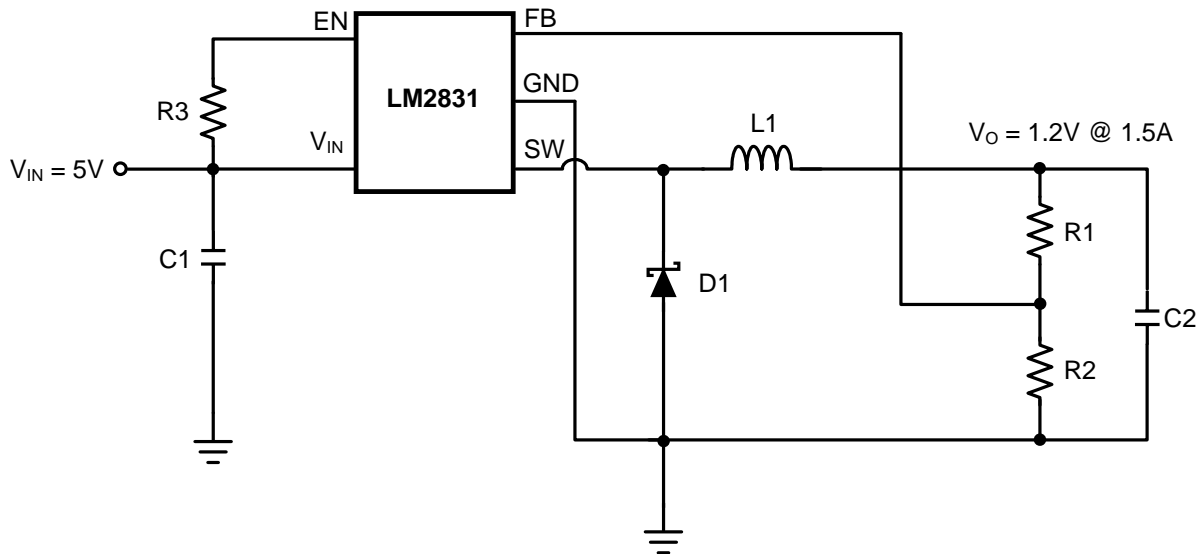
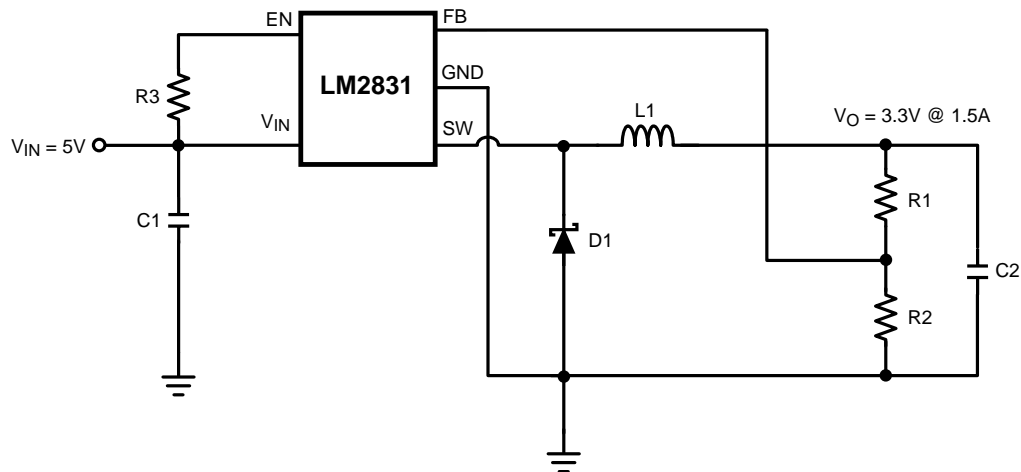

Figure 27. LM2831Y (550 kHz): $V_{IN} = 5\text{ V}$, $V_{OUT} = 1.2\text{ V}$ at 1.5 A

Table 5. Bill of Materials

PART ID	PART VALUE	MANUFACTURER	PART NUMBER
U1	1.5-A Buck Regulator	TI	LM2831Y
C1, Input Cap	22 μF , 6.3 V, X5R	TDK	C3216X5ROJ226M
C2, Output Cap	2x22 μF , 6.3 V, X5R	TDK	C3216X5ROJ226M
D1, Catch Diode	0.3 V_f Schottky 1.5 A, 30 V_R	TOSHIBA	CRS08
L1	6.8 μH 1.8 A	TDK	SLF7045T-6R8M1R7
R1	10.0 $\text{k}\Omega$, 1%	Vishay	CRCW08051002F
R2	10.0 $\text{k}\Omega$, 1%	Vishay	CRCW08051002F

8.2.6 LM2831Z Design Example 6

Figure 28. LM2831Z (3 MHz): $V_{IN} = 5\text{ V}$, $V_O = 3.3\text{ V}$ at 1.5 A
Table 6. Bill of Materials

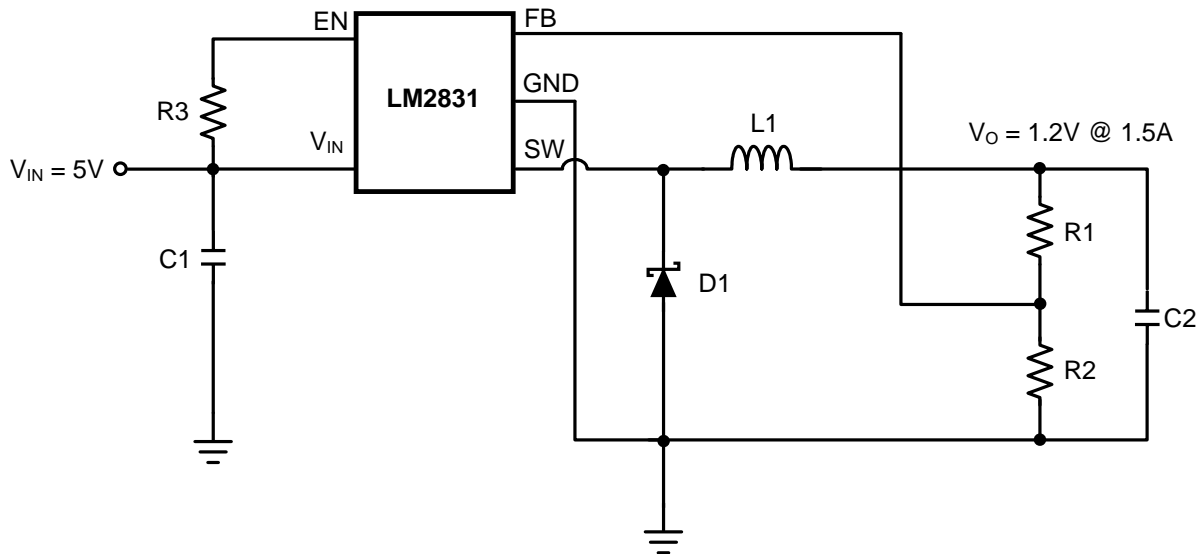
PART ID	PART VALUE	MANUFACTURER	PART NUMBER
U1	1.5-A Buck Regulator	TI	LM2831Z
C1, Input Cap	22 μF , 6.3 V, X5R	TDK	C3216X5ROJ226M
C2, Output Cap	2x22 μF , 6.3 V, X5R	TDK	C3216X5ROJ226M
D1, Catch Diode	0.3 V_f Schottky 1.5 A, 30 V_R	TOSHIBA	CRS08
L1	1.6 μH 2.0 A	TDK	VLCF4018T-1R6N1R7-2
R2	10.0 $\text{k}\Omega$, 1%	Vishay	CRCW08051002F
R1	45.3 $\text{k}\Omega$, 1%	Vishay	CRCW08054532F
R3	100 $\text{k}\Omega$, 1%	Vishay	CRCW08051003F

8.2.7 LM2831Z Design Example 7

Figure 29. LM2831Z (3 MHz): $V_{IN} = 5\text{ V}$, $V_O = 1.2\text{ V}$ at 1.5 A
Table 7. Bill of Materials

PART ID	PART VALUE	MANUFACTURER	PART NUMBER
U1	1.5-A Buck Regulator	TI	LM2831Z
C1, Input Cap	22 μF , 6.3 V, X5R	TDK	C3216X5ROJ226M
C2, Output Cap	2x22 μF , 6.3 V, X5R	TDK	C3216X5ROJ226M
D1, Catch Diode	0.3 V_f Schottky 1.5 A, 30 V_R	TOSHIBA	CRS08
L1	1.6 μH , 2.0 A	TDK	VLCF4018T- 1R6N1R7-2
R2	10.0 k Ω , 1%	Vishay	CRCW08051002F
R1	10.0 k Ω , 1%	Vishay	CRCW08051002F
R3	100 k Ω , 1%	Vishay	CRCW08051003F

8.2.8 LM2831X Dual Converters with Delayed Enabled Design Example 8

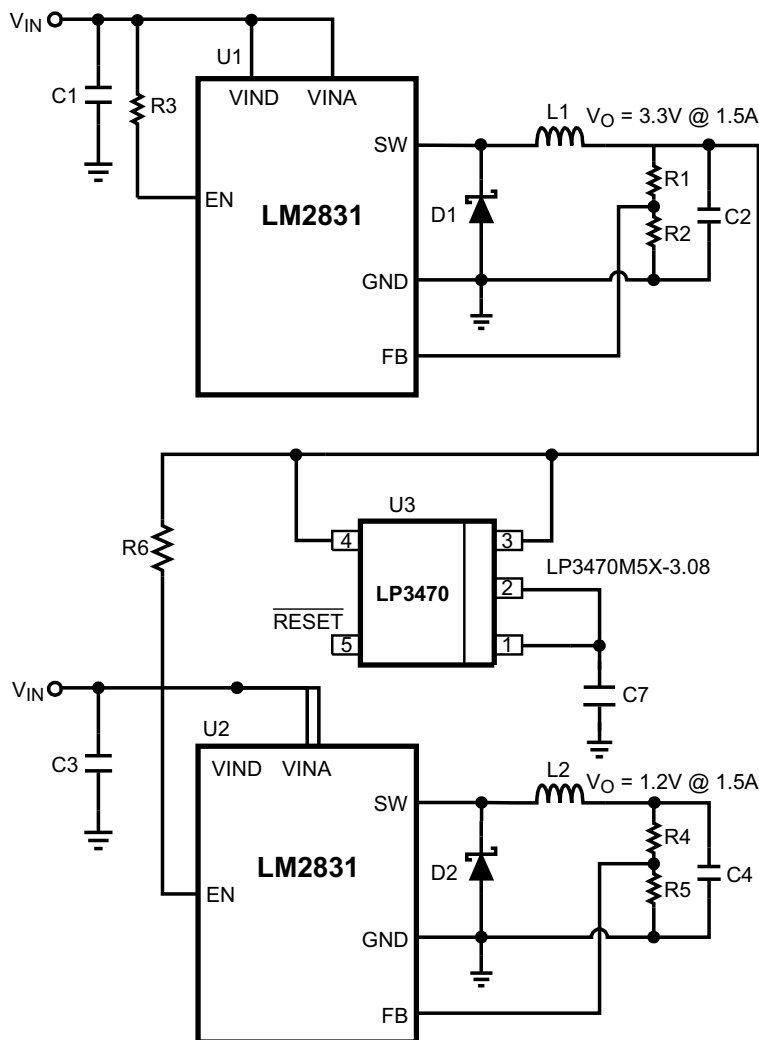
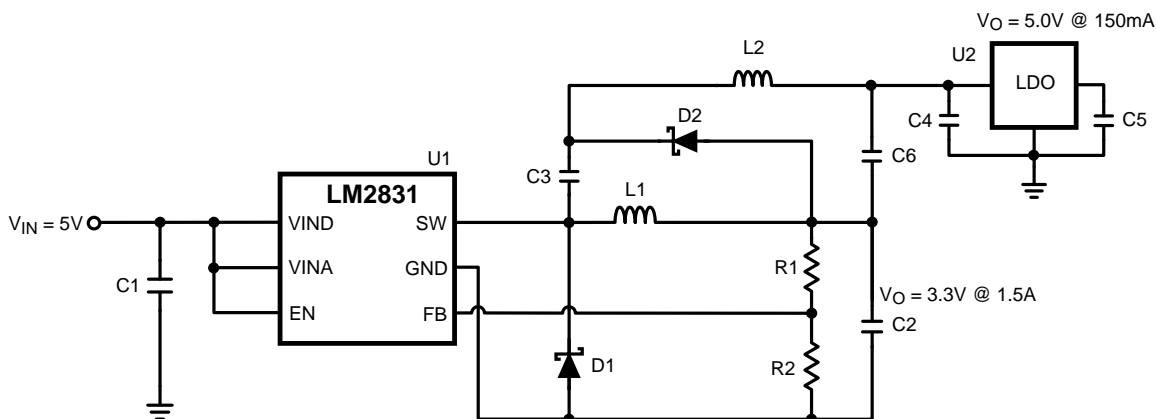

Figure 30. LM2831X (1.6 MHz): $V_{IN} = 5\text{ V}$, $V_O = 1.2\text{ V}$ at 1.5 A and 3.3 V at 1.5 A

Table 8. Bill of Materials

PART ID	PART VALUE	MANUFACTURER	PART NUMBER
U1, U2	1.5-A Buck Regulator	TI	LM2831X
U3	Power on Reset	TI	LP3470M5X-3.08
C1, C3 Input Cap	22 μF , 6.3 V, X5R	TDK	C3216X5ROJ226M
C2, C4 Output Cap	2x22 μF , 6.3 V, X5R	TDK	C3216X5ROJ226M
C7	Trr delay capacitor	TDK	
D1, D2 Catch Diode	0.3 V _f Schottky 1.5 A, 30 V _R	TOSHIBA	CRS08
L1, L2	3.3 μH , 2.2 A	TDK	VLCF5020T-3R3N2R0-1
R2, R4, R5	10.0 k Ω , 1%	Vishay	CRCW08051002F
R1, R6	45.3 k Ω , 1%	Vishay	CRCW08054532F
R3	100 k Ω , 1%	Vishay	CRCW08051003F

8.2.9 LM2831X Buck Converter and Voltage Double Circuit With LDO Follower Design Example 9

Figure 31. LM2831X (1.6 MHz): $V_{IN} = 5\text{ V}$, $V_O = 3.3\text{ V}$ at 1.5 A and LP2986-5.0 at 150 mA
Table 9. Bill of Materials

PART ID	PART VALUE	MANUFACTURER	PART NUMBER
U1	1.5-A Buck Regulator	TI	LM2831X
U2	200-mA LDO	TI	LP2986-5.0
C1, Input Cap	22 μF , 6.3 V, X5R	TDK	C3216X5ROJ226M
C2, Output Cap	22 μF , 6.3 V, X5R	TDK	C3216X5ROJ226M
C3 – C6	2.2 μF , 6.3 V, X5R	TDK	C1608X5R0J225M
D1, Catch Diode	0.3 V_f Schottky 1.5 A, 30 V_R	TOSHIBA	CRS08
D2	0.4 V_f Schottky 20 V_R , 500 mA	ON Semi	MBR0520
L2	10 μH , 800 mA	CoilCraft	ME3220-103
L1	3.3 μH , 2.2 A	TDK	VLCF5020T-3R3N2R0-1
R2	45.3 k Ω , 1%	Vishay	CRCW08054532F
R1	10.0 k Ω , 1%	Vishay	CRCW08051002F

9 Power Supply Recommendations

The LM2831 device is designed to operate from various DC power supplies. The impedance of the input supply rail should be low enough that the input current transient does not cause a drop below the UVLO level. If the input supply is connected by using long wires, additional bulk capacitance may be required in addition to normal input capacitor.

10 Layout

10.1 Layout Guidelines

When planning layout there are a few things to consider when trying to achieve a clean, regulated output. The most important consideration is the close coupling of the GND connections of the input capacitor and the catch diode D1. These ground ends should be close to one another and be connected to the GND plane with at least two through-holes. Place these components as close to the IC as possible. Next in importance is the location of the GND connection of the output capacitor, which should be near the GND connections of CIN and D1. There should be a continuous ground plane on the bottom layer of a two-layer board except under the switching node island. The FB pin is a high impedance node and care should be taken to make the FB trace short to avoid noise pickup and inaccurate regulation. The feedback resistors should be placed as close as possible to the IC, with the GND of R1 placed as close as possible to the GND of the IC. The V_{OUT} trace to R2 should be routed away from the inductor and any other traces that are switching. High AC currents flow through the V_{IN} , SW and V_{OUT} traces, so they should be as short and wide as possible. However, making the traces wide increases radiated noise, so the designer must make this trade-off. Radiated noise can be decreased by choosing a shielded inductor. The remaining components should also be placed as close as possible to the IC. See Application Note AN-1229 [SNVA054](#) for further considerations and the LM2831 demo board as an example of a 4-layer layout.

10.1.1 Calculating Efficiency and Junction Temperature

The complete LM2831 DC-DC converter efficiency can be calculated in the following manner.

$$\eta = \frac{P_{OUT}}{P_{IN}} \quad (15)$$

Or

$$\eta = \frac{P_{OUT}}{P_{OUT} + P_{LOSS}} \quad (16)$$

Calculations for determining the most significant power losses are shown below. Other losses totaling less than 2% are not discussed.

Power loss (P_{LOSS}) is the sum of two basic types of losses in the converter: switching and conduction. Conduction losses usually dominate at higher output loads, whereas switching losses remain relatively fixed and dominate at lower output loads. The first step in determining the losses is to calculate the duty cycle (D):

$$D = \frac{V_{OUT} + V_D}{V_{IN} + V_D - V_{SW}} \quad (17)$$

V_{SW} is the voltage drop across the internal PFET when it is on, and is equal to:

$$V_{SW} = I_{OUT} \times R_{DS(on)} \quad (18)$$

V_D is the forward voltage drop across the Schottky catch diode. It can be obtained from the diode manufacturer's [Electrical Characteristics](#) section. If the voltage drop across the inductor (V_{DCR}) is accounted for, the equation becomes:

$$D = \frac{V_{OUT} + V_D + V_{DCR}}{V_{IN} + V_D + V_{DCR} - V_{SW}} \quad (19)$$

The conduction losses in the free-wheeling Schottky diode are calculated as follows:

$$P_{DIODE} = V_D \times I_{OUT} \times (1-D) \quad (20)$$

Layout Guidelines (continued)

Often this is the single most significant power loss in the circuit. Care should be taken to choose a Schottky diode that has a low forward voltage drop.

Another significant external power loss is the conduction loss in the output inductor. The equation can be simplified to:

$$P_{IND} = I_{OUT}^2 \times R_{DCR} \quad (21)$$

The LM2831 conduction loss is mainly associated with the internal PFET:

$$P_{COND} = (I_{OUT}^2 \times D) \left(1 + \frac{1}{3} \times \left(\frac{\Delta i_L}{I_{OUT}} \right)^2 \right) R_{DS(ON)} \quad (22)$$

If the inductor ripple current is fairly small, the conduction losses can be simplified to:

$$P_{COND} = I_{OUT}^2 \times R_{DS(ON)} \times D \quad (23)$$

Switching losses are also associated with the internal PFET. They occur during the switch on and off transition periods, where voltages and currents overlap resulting in power loss. The simplest means to determine this loss is to empirically measuring the rise and fall times (10% to 90%) of the switch at the switch node.

Switching power loss is calculated as follows:

$$P_{SWR} = 1/2(V_{IN} \times I_{OUT} \times F_{SW} \times T_{RISE}) \quad (24)$$

$$P_{SWF} = 1/2(V_{IN} \times I_{OUT} \times F_{SW} \times T_{FALL}) \quad (25)$$

$$P_{SW} = P_{SWR} + P_{SWF} \quad (26)$$

Another loss is the power required for operation of the internal circuitry:

$$P_Q = I_Q \times V_{IN} \quad (27)$$

I_Q is the quiescent operating current, and is typically around 2.5 mA for the 0.55-MHz frequency option.

Typical application power losses are:

Table 10. Power Loss Tabulation

PARAMETER	VALUE	PARAMETER	VALUE
V_{IN}	5 V		
V_{OUT}	3.3 V	P_{OUT}	4.125 W
I_{OUT}	1.25 A		
V_D	0.45 V	P_{DIODE}	188 mW
F_{SW}	550 kHz		
I_Q	2.5 mA	P_Q	12.5 mW
T_{RISE}	4 nS	P_{SWR}	7 mW
T_{FALL}	4 nS	P_{SWF}	7 mW
$R_{DS(ON)}$	150 mΩ	P_{COND}	156 mW
$R_{IND(DCR)}$	70 mΩ	P_{IND}	110 mW
D	0.667	P_{LOSS}	481 mW
η	88%	$P_{INTERNAL}$	183 mW

$$\Sigma P_{COND} + P_{SW} + P_{DIODE} + P_{IND} + P_Q = P_{LOSS} \quad (28)$$

$$\Sigma P_{COND} + P_{SWF} + P_{SWR} + P_Q = P_{INTERNAL} \quad (29)$$

$$P_{INTERNAL} = 183 \text{ mW} \quad (30)$$

10.1.2 Thermal Definitions

T_J	Chip junction temperature
T_A	Ambient temperature
$R_{\theta JC}$	Thermal resistance from chip junction to device case
$R_{\theta JA}$	Thermal resistance from chip junction to ambient air

Heat in the LM2831 due to internal power dissipation is removed through conduction and/or convection.

Conduction Heat transfer occurs through cross sectional areas of material. Depending on the material, the transfer of heat can be considered to have poor to good thermal conductivity properties (insulator vs. conductor).

Heat Transfer goes as:

Silicon → package → lead frame → PCB

Convection: Heat transfer is by means of airflow. This could be from a fan or natural convection. Natural convection occurs when air currents rise from the hot device to cooler air.

Thermal impedance is defined as:

$$R_{\theta} = \frac{\Delta T}{\text{Power}} \quad (31)$$

Thermal impedance from the silicon junction to the ambient air is defined as:

$$R_{\theta JA} = \frac{T_J - T_A}{\text{Power}} \quad (32)$$

The PCB size, weight of copper used to route traces and ground plane, and number of layers within the PCB can greatly effect $R_{\theta JA}$. The type and number of thermal vias can also make a large difference in the thermal impedance. Thermal vias are necessary in most applications. They conduct heat from the surface of the PCB to the ground plane. Four to six thermal vias should be placed under the exposed pad to the ground plane if the WSON package is used.

Thermal impedance also depends on the thermal properties of the application operating conditions (V_{in} , V_o , I_o , and so forth), and the surrounding circuitry.

10.1.2.1 Silicon Junction Temperature Determination Method 1

To accurately measure the silicon temperature for a given application, two methods can be used. The first method requires the user to know the thermal impedance of the silicon junction to top case temperature.

Some clarification must be made before we go any further.

$R_{\theta JC}$ is the thermal impedance from all six sides of an IC package to silicon junction.

$R_{\phi JC}$ is the thermal impedance from top case to the silicon junction.

In this data sheet we will use $R_{\phi JC}$ so that it allows the user to measure top case temperature with a small thermocouple attached to the top case.

$R_{\phi JC}$ is approximately 30°C/Watt for the 6-pin WSON package with the exposed pad. Knowing the internal dissipation from the efficiency calculation given previously, and the case temperature, which can be empirically measured on the bench we have:

$$R_{\phi JC} = \frac{T_J - T_C}{\text{Power}} \quad (33)$$

Therefore:

$$T_J = (R_{\phi JC} \times P_{\text{LOSS}}) + T_C \quad (34)$$

From the previous example:

$$T_J = (R_{\phi JC} \times P_{\text{INTERNAL}}) + T_C \quad (35)$$

$$T_J = 30^{\circ}\text{C/W} \times 0.189 \text{ W} + T_C \quad (36)$$

The second method can give a very accurate silicon junction temperature.

The first step is to determine $R_{\theta JA}$ of the application. The LM2831 has overtemperature protection circuitry. When the silicon temperature reaches 165°C, the device stops switching. The protection circuitry has a hysteresis of about 15°C. Once the silicon temperature has decreased to approximately 150°C, the device will start to switch again. Knowing this, the $R_{\theta JA}$ for any application can be characterized during the early stages of the design one may calculate the $R_{\theta JA}$ by placing the PCB circuit into a thermal chamber. Raise the ambient temperature in the given working application until the circuit enters thermal shutdown. If the SW-pin is monitored, it will be obvious when the internal PFET stops switching, indicating a junction temperature of 165°C. Knowing the internal power dissipation from the above methods, the junction temperature, and the ambient temperature $R_{\theta JA}$ can be determined.

$$R_{\theta JA} = \frac{165^{\circ}\text{C} - T_a}{P_{\text{INTERNAL}}} \quad (37)$$

Once this is determined, the maximum ambient temperature allowed for a desired junction temperature can be found.

An example of calculating $R_{\theta JA}$ for an application using the Texas Instruments LM2831 WSON demonstration board is shown below.

The four layer PCB is constructed using FR4 with ½ oz copper traces. The copper ground plane is on the bottom layer. The ground plane is accessed by two vias. The board measures 3 cm × 3 cm. It was placed in an oven with no forced airflow. The ambient temperature was raised to 144°C, and at that temperature, the device went into thermal shutdown.

From the previous example:

$$P_{\text{INTERNAL}} = 189 \text{ mW} \quad (38)$$

$$R_{\theta JA} = \frac{165^{\circ}\text{C} - 144^{\circ}\text{C}}{189 \text{ mW}} = 111^{\circ}\text{C} / \text{W} \quad (39)$$

If the junction temperature was to be kept below 125°C, then the ambient temperature could not go above 109°C

$$T_j - (R_{\theta JA} \times P_{\text{LOSS}}) = T_a \quad (40)$$

$$125^{\circ}\text{C} - (111^{\circ}\text{C}/\text{W} \times 189 \text{ mW}) = 104^{\circ}\text{C} \quad (41)$$

10.1.3 WSON Package

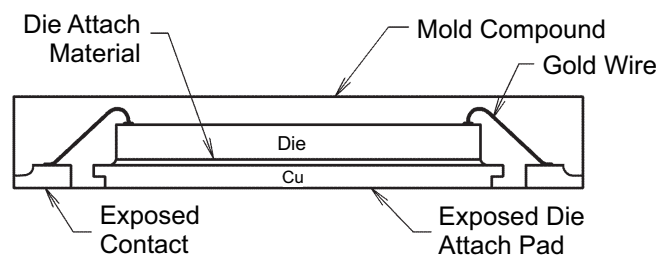

Figure 32. Internal WSON Connection

For certain high power applications, the PCB land may be modified to a "dog bone" shape (see [Figure 33](#)). By increasing the size of ground plane, and adding thermal vias, the $R_{\theta JA}$ for the application can be reduced.

10.2 Layout Example

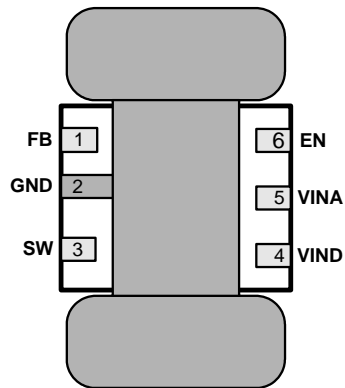

Figure 33. 6-Lead WSON PCB Dog Bone Layout

11 Device and Documentation Support

11.1 Device Support

11.1.1 Third-Party Products Disclaimer

TI'S PUBLICATION OF INFORMATION REGARDING THIRD-PARTY PRODUCTS OR SERVICES DOES NOT CONSTITUTE AN ENDORSEMENT REGARDING THE SUITABILITY OF SUCH PRODUCTS OR SERVICES OR A WARRANTY, REPRESENTATION OR ENDORSEMENT OF SUCH PRODUCTS OR SERVICES, EITHER ALONE OR IN COMBINATION WITH ANY TI PRODUCT OR SERVICE.

11.2 Documentation Support

11.2.1 Related Documentation

For related documentation, see the following:

AN-1229 SIMPLE SWITCHER® PCB Layout Guidelines, [SNVA054](#)

11.3 Community Resources

The following links connect to TI community resources. Linked contents are provided "AS IS" by the respective contributors. They do not constitute TI specifications and do not necessarily reflect TI's views; see TI's [Terms of Use](#).

TI E2E™ Online Community *TI's Engineer-to-Engineer (E2E) Community*. Created to foster collaboration among engineers. At [e2e.ti.com](#), you can ask questions, share knowledge, explore ideas and help solve problems with fellow engineers.

Design Support *TI's Design Support* Quickly find helpful E2E forums along with design support tools and contact information for technical support.

11.4 Trademarks

E2E is a trademark of Texas Instruments.
All other trademarks are the property of their respective owners.

11.5 Electrostatic Discharge Caution



These devices have limited built-in ESD protection. The leads should be shorted together or the device placed in conductive foam during storage or handling to prevent electrostatic damage to the MOS gates.

11.6 Glossary

[SLYZ022](#) — *TI Glossary*.

This glossary lists and explains terms, acronyms, and definitions.

12 Mechanical, Packaging, and Orderable Information

The following pages include mechanical, packaging, and orderable information. This information is the most current data available for the designated devices. This data is subject to change without notice and revision of this document. For browser-based versions of this data sheet, refer to the left-hand navigation.

PACKAGING INFORMATION

Orderable Device	Status (1)	Package Type	Package Drawing	Pins	Package Qty	Eco Plan (2)	Lead/Ball Finish (6)	MSL Peak Temp (3)	Op Temp (°C)	Device Marking (4/5)	Samples
LM2831XMF/NOPB	ACTIVE	SOT-23	DBV	5	1000	Green (RoHS & no Sb/Br)	CU SN	Level-1-260C-UNLIM	-40 to 125	SKYB	Samples
LM2831XMF/NOPB	ACTIVE	SOT-23	DBV	5	3000	Green (RoHS & no Sb/Br)	CU SN	Level-1-260C-UNLIM	-40 to 125	SKYB	Samples
LM2831XSD	NRND	WSON	NGG	6	1000	TBD	Call TI	Call TI	-40 to 125	L193B	
LM2831XSD/NOPB	ACTIVE	WSON	NGG	6	1000	Green (RoHS & no Sb/Br)	CU SN	Level-3-260C-168 HR	-40 to 125	L193B	Samples
LM2831XSDX/NOPB	ACTIVE	WSON	NGG	6	4500	Green (RoHS & no Sb/Br)	CU SN	Level-3-260C-168 HR	-40 to 125	L193B	Samples
LM2831YMF/NOPB	ACTIVE	SOT-23	DBV	5	1000	Green (RoHS & no Sb/Br)	CU SN	Level-1-260C-UNLIM	-40 to 125	SKZB	Samples
LM2831YMF/NOPB	ACTIVE	SOT-23	DBV	5	3000	Green (RoHS & no Sb/Br)	CU SN	Level-1-260C-UNLIM	-40 to 125	SKZB	Samples
LM2831YSD/NOPB	ACTIVE	WSON	NGG	6	1000	Green (RoHS & no Sb/Br)	CU SN	Level-3-260C-168 HR	-40 to 125	L194B	Samples
LM2831YSDX/NOPB	ACTIVE	WSON	NGG	6		TBD	Call TI	Call TI	-40 to 125	L194B	Samples
LM2831ZMF/NOPB	ACTIVE	SOT-23	DBV	5	1000	Green (RoHS & no Sb/Br)	CU SN	Level-1-260C-UNLIM	-40 to 125	SLAB	Samples
LM2831ZMF/NOPB	ACTIVE	SOT-23	DBV	5		TBD	Call TI	Call TI	-40 to 125	SLAB	Samples
LM2831ZSD/NOPB	ACTIVE	WSON	NGG	6	1000	Green (RoHS & no Sb/Br)	CU SN	Level-3-260C-168 HR	-40 to 125	L195B	Samples
LM2831ZSDX/NOPB	ACTIVE	WSON	NGG	6		TBD	Call TI	Call TI	-40 to 125	L195B	Samples

(1) The marketing status values are defined as follows:

ACTIVE: Product device recommended for new designs.

LIFEBUY: TI has announced that the device will be discontinued, and a lifetime-buy period is in effect.

NRND: Not recommended for new designs. Device is in production to support existing customers, but TI does not recommend using this part in a new design.

PREVIEW: Device has been announced but is not in production. Samples may or may not be available.

OBSOLETE: TI has discontinued the production of the device.

(2) Eco Plan - The planned eco-friendly classification: Pb-Free (RoHS), Pb-Free (RoHS Exempt), or Green (RoHS & no Sb/Br) - please check <http://www.ti.com/productcontent> for the latest availability information and additional product content details.

TBD: The Pb-Free/Green conversion plan has not been defined.

Pb-Free (RoHS): TI's terms "Lead-Free" or "Pb-Free" mean semiconductor products that are compatible with the current RoHS requirements for all 6 substances, including the requirement that lead not exceed 0.1% by weight in homogeneous materials. Where designed to be soldered at high temperatures, TI Pb-Free products are suitable for use in specified lead-free processes.

Pb-Free (RoHS Exempt): This component has a RoHS exemption for either 1) lead-based flip-chip solder bumps used between the die and package, or 2) lead-based die adhesive used between the die and leadframe. The component is otherwise considered Pb-Free (RoHS compatible) as defined above.

Green (RoHS & no Sb/Br): TI defines "Green" to mean Pb-Free (RoHS compatible), and free of Bromine (Br) and Antimony (Sb) based flame retardants (Br or Sb do not exceed 0.1% by weight in homogeneous material)

⁽³⁾ MSL, Peak Temp. - The Moisture Sensitivity Level rating according to the JEDEC industry standard classifications, and peak solder temperature.

⁽⁴⁾ There may be additional marking, which relates to the logo, the lot trace code information, or the environmental category on the device.

⁽⁵⁾ Multiple Device Markings will be inside parentheses. Only one Device Marking contained in parentheses and separated by a "~" will appear on a device. If a line is indented then it is a continuation of the previous line and the two combined represent the entire Device Marking for that device.

⁽⁶⁾ Lead/Ball Finish - Orderable Devices may have multiple material finish options. Finish options are separated by a vertical ruled line. Lead/Ball Finish values may wrap to two lines if the finish value exceeds the maximum column width.

Important Information and Disclaimer:The information provided on this page represents TI's knowledge and belief as of the date that it is provided. TI bases its knowledge and belief on information provided by third parties, and makes no representation or warranty as to the accuracy of such information. Efforts are underway to better integrate information from third parties. TI has taken and continues to take reasonable steps to provide representative and accurate information but may not have conducted destructive testing or chemical analysis on incoming materials and chemicals. TI and TI suppliers consider certain information to be proprietary, and thus CAS numbers and other limited information may not be available for release.

In no event shall TI's liability arising out of such information exceed the total purchase price of the TI part(s) at issue in this document sold by TI to Customer on an annual basis.

TAPE AND REEL INFORMATION



QUADRANT ASSIGNMENTS FOR PIN 1 ORIENTATION IN TAPE



*All dimensions are nominal

Device	Package Type	Package Drawing	Pins	SPQ	Reel Diameter (mm)	Reel Width W1 (mm)	A0 (mm)	B0 (mm)	K0 (mm)	P1 (mm)	W (mm)	Pin1 Quadrant
LM2831XMF/NOPB	SOT-23	DBV	5	1000	178.0	8.4	3.2	3.2	1.4	4.0	8.0	Q3
LM2831XMF/NOPB	SOT-23	DBV	5	3000	178.0	8.4	3.2	3.2	1.4	4.0	8.0	Q3
LM2831XSD	WSON	NGG	6	1000	178.0	12.4	3.3	3.3	1.0	8.0	12.0	Q1
LM2831XSD/NOPB	WSON	NGG	6	1000	178.0	12.4	3.3	3.3	1.0	8.0	12.0	Q1
LM2831XSD/NOPB	WSON	NGG	6	4500	330.0	12.4	3.3	3.3	1.0	8.0	12.0	Q1
LM2831YMF/NOPB	SOT-23	DBV	5	1000	178.0	8.4	3.2	3.2	1.4	4.0	8.0	Q3
LM2831YMF/NOPB	SOT-23	DBV	5	3000	178.0	8.4	3.2	3.2	1.4	4.0	8.0	Q3
LM2831YSD/NOPB	WSON	NGG	6	1000	178.0	12.4	3.3	3.3	1.0	8.0	12.0	Q1
LM2831ZMF/NOPB	SOT-23	DBV	5	1000	178.0	8.4	3.2	3.2	1.4	4.0	8.0	Q3
LM2831ZSD/NOPB	WSON	NGG	6	1000	178.0	12.4	3.3	3.3	1.0	8.0	12.0	Q1

TAPE AND REEL BOX DIMENSIONS

*All dimensions are nominal

Device	Package Type	Package Drawing	Pins	SPQ	Length (mm)	Width (mm)	Height (mm)
LM2831XMF/NOPB	SOT-23	DBV	5	1000	210.0	185.0	35.0
LM2831XMF/NOPB	SOT-23	DBV	5	3000	210.0	185.0	35.0
LM2831XSD	WSON	NGG	6	1000	213.0	191.0	55.0
LM2831XSD/NOPB	WSON	NGG	6	1000	213.0	191.0	55.0
LM2831XSDX/NOPB	WSON	NGG	6	4500	367.0	367.0	35.0
LM2831YMF/NOPB	SOT-23	DBV	5	1000	210.0	185.0	35.0
LM2831YMF/NOPB	SOT-23	DBV	5	3000	210.0	185.0	35.0
LM2831YSD/NOPB	WSON	NGG	6	1000	213.0	191.0	55.0
LM2831ZMF/NOPB	SOT-23	DBV	5	1000	210.0	185.0	35.0
LM2831ZSD/NOPB	WSON	NGG	6	1000	213.0	191.0	55.0

DBV (R-PDSO-G5)

PLASTIC SMALL-OUTLINE PACKAGE

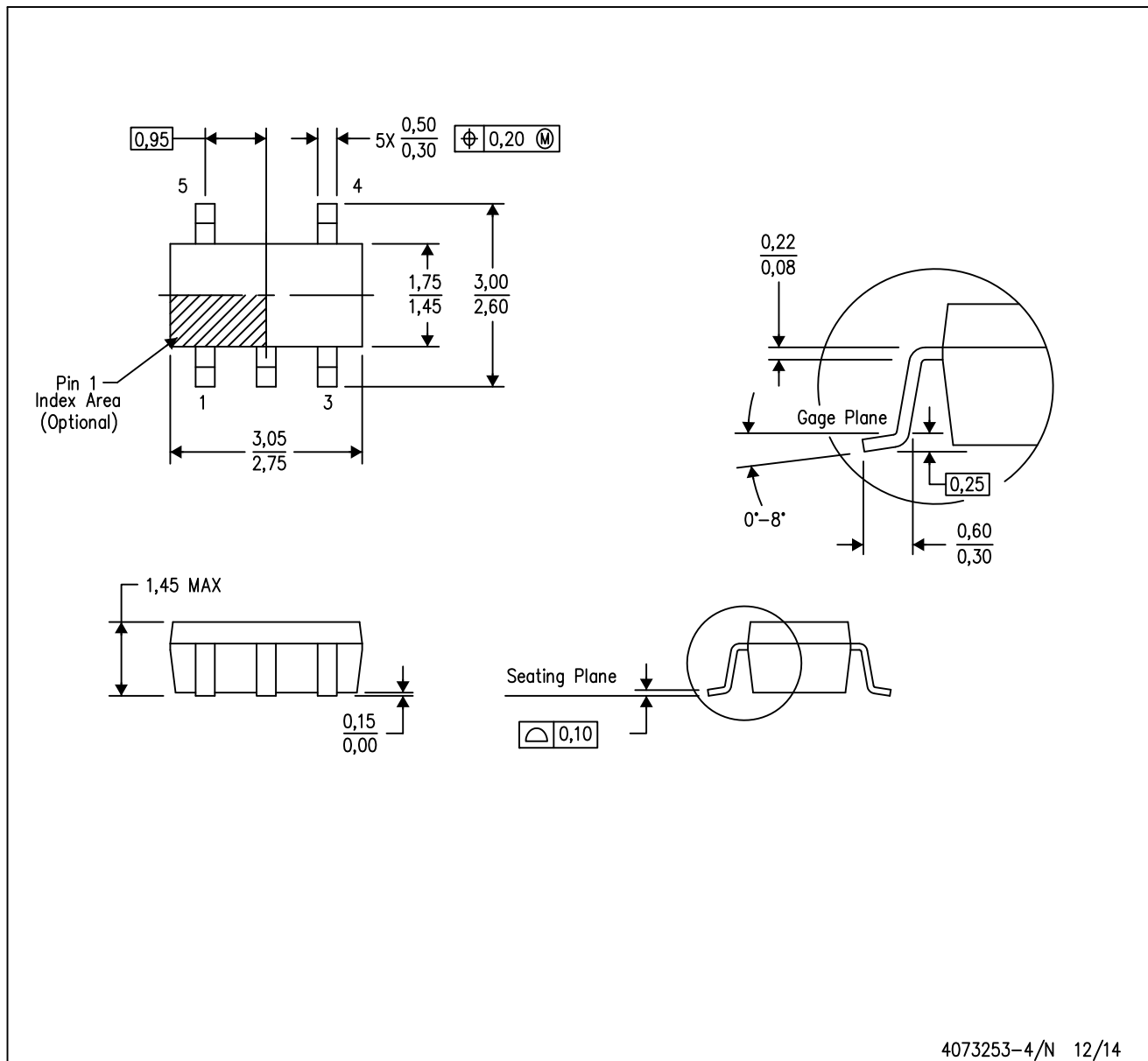

- NOTES:
- A. All linear dimensions are in millimeters.
 - B. This drawing is subject to change without notice.
 - C. Body dimensions do not include mold flash or protrusion. Mold flash and protrusion shall not exceed 0.15 per side.
 - D. Falls within JEDEC MO-178 Variation AA.

DBV (R-PDSO-G5)

PLASTIC SMALL OUTLINE

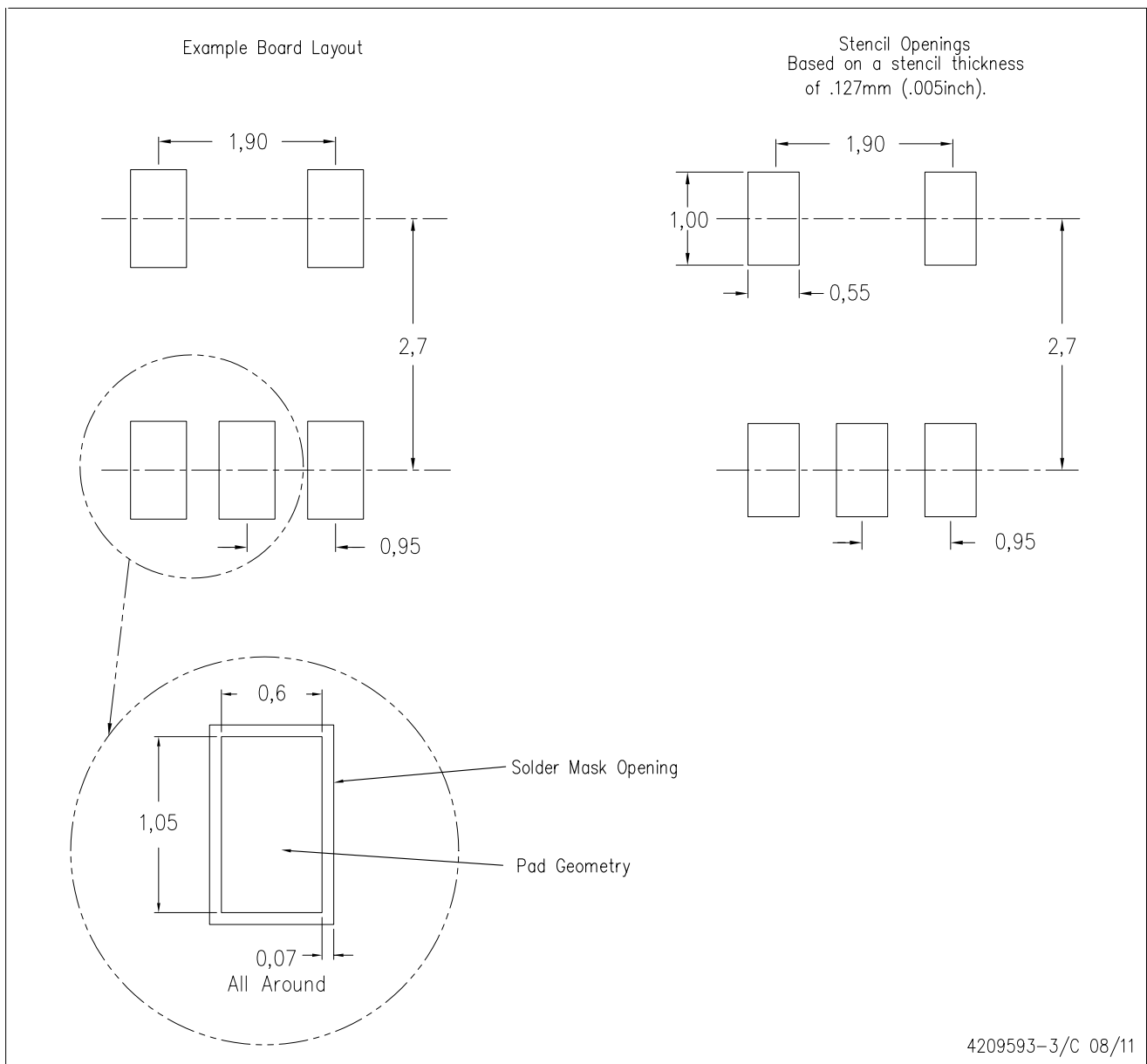

- NOTES:
- A. All linear dimensions are in millimeters.
 - B. This drawing is subject to change without notice.
 - C. Customers should place a note on the circuit board fabrication drawing not to alter the center solder mask defined pad.
 - D. Publication IPC-7351 is recommended for alternate designs.
 - E. Laser cutting apertures with trapezoidal walls and also rounding corners will offer better paste release. Customers should contact their board assembly site for stencil design recommendations. Example stencil design based on a 50% volumetric metal load solder paste. Refer to IPC-7525 for other stencil recommendations.

NGG0006A

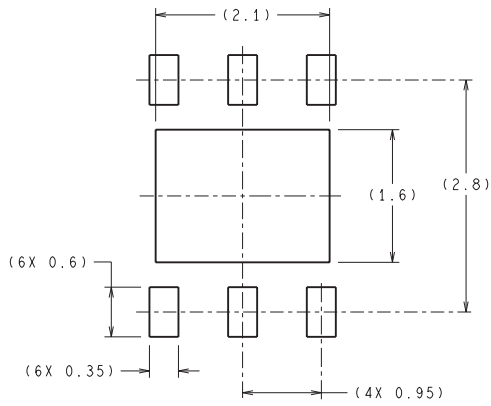

DIMENSIONS ARE IN MILLIMETERS
DIMENSION IN () FOR REFERENCE ONLY

RECOMMENDED LAND PATTERN

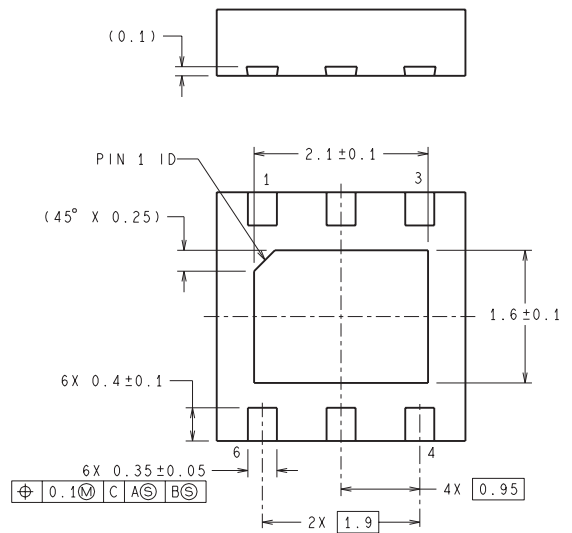
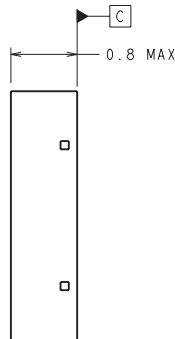
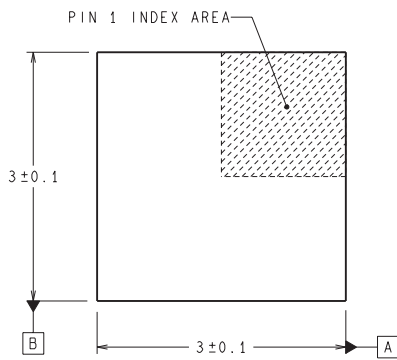

SDE06A (Rev A)

IMPORTANT NOTICE

Texas Instruments Incorporated and its subsidiaries (TI) reserve the right to make corrections, enhancements, improvements and other changes to its semiconductor products and services per JESD46, latest issue, and to discontinue any product or service per JESD48, latest issue. Buyers should obtain the latest relevant information before placing orders and should verify that such information is current and complete. All semiconductor products (also referred to herein as "components") are sold subject to TI's terms and conditions of sale supplied at the time of order acknowledgment.

TI warrants performance of its components to the specifications applicable at the time of sale, in accordance with the warranty in TI's terms and conditions of sale of semiconductor products. Testing and other quality control techniques are used to the extent TI deems necessary to support this warranty. Except where mandated by applicable law, testing of all parameters of each component is not necessarily performed.

TI assumes no liability for applications assistance or the design of Buyers' products. Buyers are responsible for their products and applications using TI components. To minimize the risks associated with Buyers' products and applications, Buyers should provide adequate design and operating safeguards.

TI does not warrant or represent that any license, either express or implied, is granted under any patent right, copyright, mask work right, or other intellectual property right relating to any combination, machine, or process in which TI components or services are used. Information published by TI regarding third-party products or services does not constitute a license to use such products or services or a warranty or endorsement thereof. Use of such information may require a license from a third party under the patents or other intellectual property of the third party, or a license from TI under the patents or other intellectual property of TI.

Reproduction of significant portions of TI information in TI data books or data sheets is permissible only if reproduction is without alteration and is accompanied by all associated warranties, conditions, limitations, and notices. TI is not responsible or liable for such altered documentation. Information of third parties may be subject to additional restrictions.

Resale of TI components or services with statements different from or beyond the parameters stated by TI for that component or service voids all express and any implied warranties for the associated TI component or service and is an unfair and deceptive business practice. TI is not responsible or liable for any such statements.

Buyer acknowledges and agrees that it is solely responsible for compliance with all legal, regulatory and safety-related requirements concerning its products, and any use of TI components in its applications, notwithstanding any applications-related information or support that may be provided by TI. Buyer represents and agrees that it has all the necessary expertise to create and implement safeguards which anticipate dangerous consequences of failures, monitor failures and their consequences, lessen the likelihood of failures that might cause harm and take appropriate remedial actions. Buyer will fully indemnify TI and its representatives against any damages arising out of the use of any TI components in safety-critical applications.

In some cases, TI components may be promoted specifically to facilitate safety-related applications. With such components, TI's goal is to help enable customers to design and create their own end-product solutions that meet applicable functional safety standards and requirements. Nonetheless, such components are subject to these terms.

No TI components are authorized for use in FDA Class III (or similar life-critical medical equipment) unless authorized officers of the parties have executed a special agreement specifically governing such use.

Only those TI components which TI has specifically designated as military grade or "enhanced plastic" are designed and intended for use in military/aerospace applications or environments. Buyer acknowledges and agrees that any military or aerospace use of TI components which have **not** been so designated is solely at the Buyer's risk, and that Buyer is solely responsible for compliance with all legal and regulatory requirements in connection with such use.

TI has specifically designated certain components as meeting ISO/TS16949 requirements, mainly for automotive use. In any case of use of non-designated products, TI will not be responsible for any failure to meet ISO/TS16949.

Products

Audio	www.ti.com/audio
Amplifiers	amplifier.ti.com
Data Converters	dataconverter.ti.com
DLP® Products	www.dlp.com
DSP	dsp.ti.com
Clocks and Timers	www.ti.com/clocks
Interface	interface.ti.com
Logic	logic.ti.com
Power Mgmt	power.ti.com
Microcontrollers	microcontroller.ti.com
RFID	www.ti-rfid.com
OMAP Applications Processors	www.ti.com/omap
Wireless Connectivity	www.ti.com/wirelessconnectivity

Applications

Automotive and Transportation	www.ti.com/automotive
Communications and Telecom	www.ti.com/communications
Computers and Peripherals	www.ti.com/computers
Consumer Electronics	www.ti.com/consumer-apps
Energy and Lighting	www.ti.com/energy
Industrial	www.ti.com/industrial
Medical	www.ti.com/medical
Security	www.ti.com/security
Space, Avionics and Defense	www.ti.com/space-avionics-defense
Video and Imaging	www.ti.com/video

TI E2E Community

e2e.ti.com

Looking for pricing, stock, or lifecycle information?

Click below to explore more details on WIN SOURCE:

- ⊖ [View LM2831ZSDX/NOPB on WIN SOURCE](#)
- ⊖ [Texas Instruments](#) Information

Optimize Your Supply Chain with WIN SOURCE Solutions

- ✓ Global Sourcing Solution
- ✓ Obsolete Management
- ✓ Cost Control Management
- ✓ Shortage Management
- ✓ Alternative Solution
- ✓ Excess Inventory Management