



**THE DATASHEET OF  
LM3211MTX-ADJ/NOPB**



## LM3211 Step-up PWM DC/DC Converter Integrated with 4 Buffers

Check for Samples: [LM3211](#)

### FEATURES

- 1.4A, 0.17 $\Omega$ , Internal Power Switch
- $V_{IN}$  Operating Range: 2.2V to 7.5V
- 600kHz/1.25MHz Selectable Frequency Step-Up DC/DC Converter
- 20 Pin TSSOP Package
- Inrush Current Limiting Circuitry
- External Softstart Override
- 4 Gamma Buffers

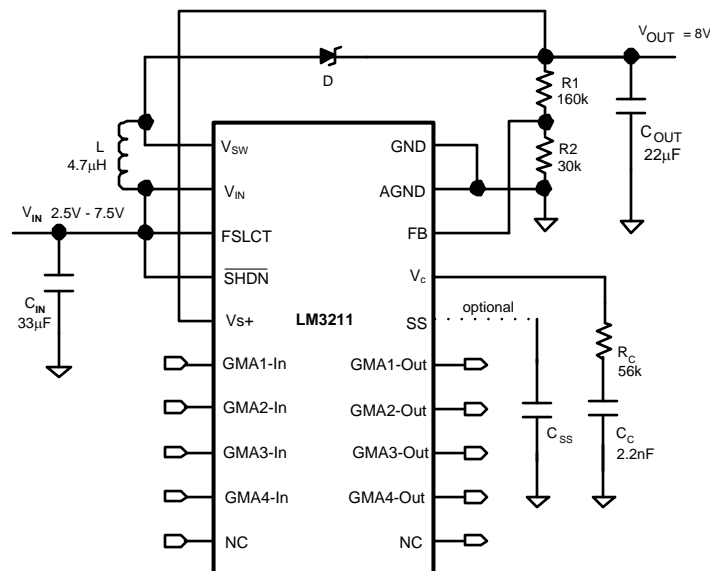
### APPLICATIONS

- LCD Bias Supplies
- Handheld Devices
- Portable Applications
- Cellular Phones/Digital Cameras

### DESCRIPTION

The LM3211 is a compact bias solution for TFT displays. It has a current mode PWM step-up DC/DC converter with a 1.4A, 0.17 $\Omega$  internal switch. Capable of generating 8V at 300mA from a Lithium Ion battery, the LM3211 is ideal for generating bias voltages for large screen LCD panels. The LM3211 can be operated at switching frequencies of 600kHz or 1.25MHz, allowing for easy filtering and low noise. An external compensation pin gives the user flexibility in setting frequency compensation, which makes possible the use of small, low ESR ceramic capacitors at the output. The LM3211 uses a patented internal circuitry to limit startup inrush current of the boost switching regulator without the use of an external softstart capacitor. An external softstart pin enables the user to tailor the softstart to a specific application. The LM3211 contains 4 Gamma buffers capable of supplying 35mA source and sink. The TSSOP-20 package ensures a low profile overall solution.

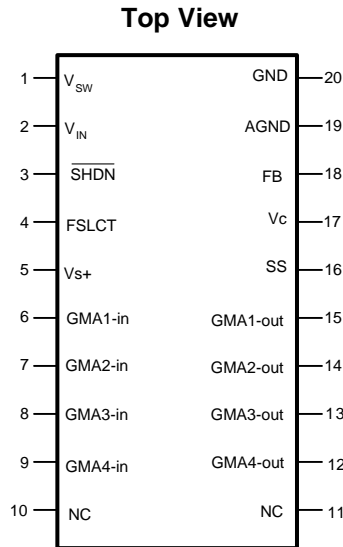
### Typical Application Circuit



Please be aware that an important notice concerning availability, standard warranty, and use in critical applications of Texas Instruments semiconductor products and disclaimers thereto appears at the end of this data sheet.

All trademarks are the property of their respective owners.

## Connection Diagram



**Figure 1. TSSOP 20 Package**  
 $T_{JMAX} = 125^{\circ}\text{C}$ ,  $\theta_{JA} = 120^{\circ}\text{C/W}$  <sup>(1)</sup>  
 See Package Number PW (R-PDSO-G20)

### PIN DESCRIPTION

Pin	Name	Function
1	$V_{SW}$	Power switch input.
2	$V_{IN}$	Switching Regulator Power input.
3	$\overline{\text{SHDN}}$	Shutdown pin, active low.
4	FSLCT	Frequency Select pin. FSLCT = $V_{IN}$ for 1.25 MHz, FSLCT = AGND or floating for 600kHz.
5	$V_{S+}$	Gamma Buffer input supply.
6	GMA1-in	Gamma Buffer input.
7	GMA2-in	Gamma Buffer input.
8	GMA3-in	Gamma Buffer input.
9	GMA4-in	Gamma Buffer input.
10	NC	No Connection, leave open.
11	NC	No Connection, leave open.
12	GMA4-out	Gamma Buffer output.
13	GMA3-out	Gamma Buffer output.
14	GMA2-out	Gamma Buffer output.
15	GMA1-out	Gamma Buffer output.
16	SS	Soft start pin.
17	$V_C$	Boost Compensation Network Connection.
18	FB	Output Voltage Feedback input.
19	AGND	Gamma Buffer ground, Analog ground connection for Regulator.
20	GND	Switch Power Ground.

- (1) The maximum allowable power dissipation is a function of the maximum junction temperature,  $T_J(\text{MAX})$ , the junction-to-ambient thermal resistance,  $\theta_{JA}$ , and the ambient temperature,  $T_A$ . See the Electrical Characteristics table for the thermal resistance of various layouts. The maximum allowable power dissipation at any ambient temperature is calculated using:  $P_D(\text{MAX}) = (T_J(\text{MAX}) - T_A)/\theta_{JA}$ . Exceeding the maximum allowable power dissipation will cause excessive die temperature, and the regulator will go into thermal shutdown.

## Pin Functions

**V<sub>SW</sub>(Pin 1):** This is the drain of the internal NMOS power switch. Minimize the metal trace area connected to this pin to minimize EMI.

**V<sub>IN</sub>(Pin 2):** Input Supply Pin. Bypass this pin with a capacitor as close to the device as possible. The capacitor should connect between V<sub>IN</sub> and GND.

**$\overline{\text{SHDN}}$ (Pin 3):** Shutdown Pin. The shutdown pin signal is active low. A voltage of less than 0.3V disables the device. A voltage greater than 0.85V enables the device.

**FSLCT(Pin 4):** Frequency Select Pin. Connecting FSLCT to AGND selects a 600 kHz operating frequency for the switching regulator. Connecting FSLCT to V<sub>IN</sub> selects a 1.25 MHz operating frequency. If FSLCT is left floating, the switching frequency defaults to 600 kHz.

**Vs+(Pin 5):** Supply pin for the four Gamma buffers. Bypass this pin with a capacitor as close to the device as possible. The capacitor should connect between Vs+ and GND.

**GMA1-in(Pin 6):** Gamma Buffer input pin.

**GMA2-in(Pin 7):** Gamma Buffer input pin.

**GMA3-in(Pin 8):** Gamma Buffer input pin.

**GMA4-in(Pin 9):** Gamma Buffer input pin.

**NC(Pin 10):** No Connection.

**NC(Pin 11):** No Connection.

**GMA4-out(Pin 12):** Gamma Buffer output pin.

**GMA3-out(Pin 13):** Gamma Buffer output pin.

**GMA2-out(Pin 14):** Gamma Buffer output pin.

**GMA1-out(Pin 15):** Gamma Buffer output pin.

**SS(Pin 16):** Softstart pin. Connect capacitor to SS pin and AGND to slowly ramp inductor current on startup.

**V<sub>C</sub>(Pin 17):** Compensation Network for Boost switching regulator. Connect resistor/capacitor network between V<sub>C</sub> pin and AGND for boost switching regulator AC compensation.

**FB(Pin 18):** Feedback pin. Set the output voltage by selecting values of R1 and R2 using:

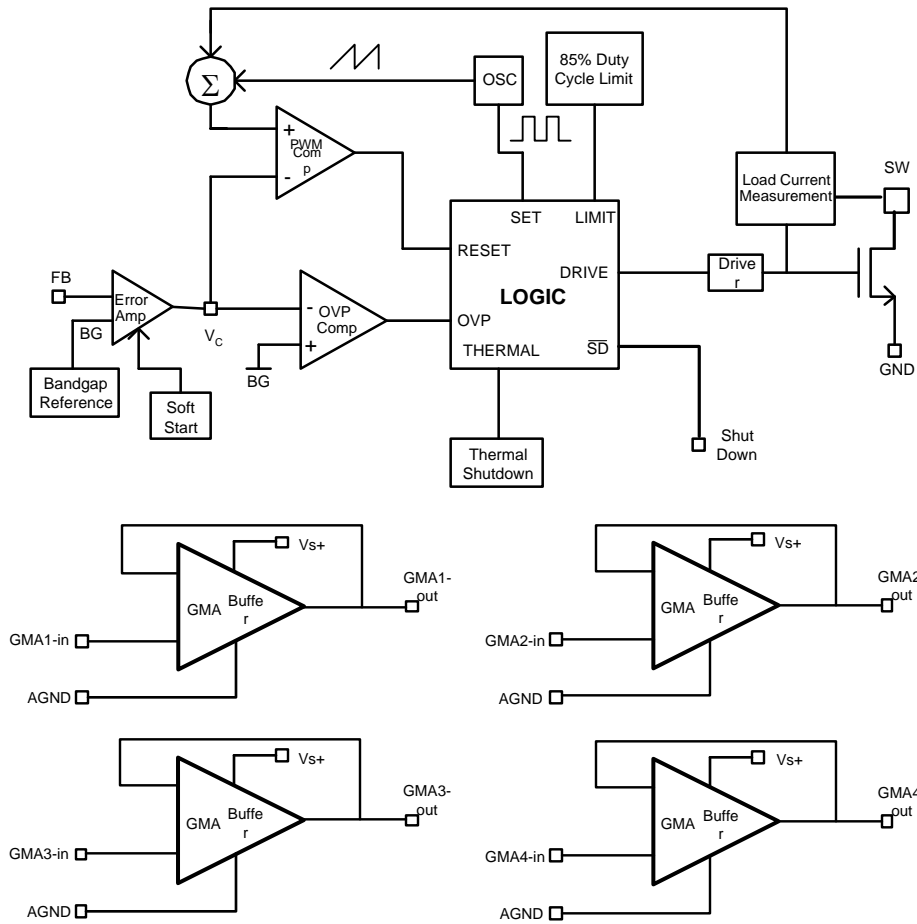
$$R1 = R2 \left( \frac{V_{OUT}}{1.265V} - 1 \right) \quad (1)$$

Connect the ground of the feedback network to the AGND plane, which can be tied directly to the GND pin.

**AGND(Pin 19):** Analog ground pin. Ground connection for the Gamma buffers and the boost switching regulator. AGND must be tied directly to GND at the pins.

**GND(Pin 20):** Power ground pin. Ground connection for the NMOS power device of the boost switching regulator. GND must be tied directly to AGND at the pins.

Block Diagram



These devices have limited built-in ESD protection. The leads should be shorted together or the device placed in conductive foam during storage or handling to prevent electrostatic damage to the MOS gates.

## Absolute Maximum Ratings<sup>(1)</sup>

$V_{IN}$		-0.3V to 7.5V
$V_{SW}$ Voltage		-0.3V to 18V
FB Voltage		-0.3V to 7V
$V_C$ Voltage		0.965V to 1.565V
$\overline{SHDN}$ Voltage		-0.3V to $V_{IN}$
FSLCT Voltage		AGND to $V_{IN}$
Supply Voltage, $V_{S+}$		-0.3V to 14V
Buffer Input Voltage		Rail-to-Rail
Buffer Output Voltage		Rail-to-Rail
ESD Ratings <sup>(2)</sup>	Human Body Model	2kV
	Machine Model	150V

- (1) Absolute maximum ratings are limits beyond which damage to the device may occur. Operating Ratings are conditions for which the device is intended to be functional, but device parameter specifications may not be ensured. For specific specifications and test conditions, see the Electrical Characteristics.
- (2) The human body model is a 100 pF capacitor discharged through a 1.5k $\Omega$  resistor into each pin. The machine model is a 200pF capacitor discharged directly into each pin.

## Operating Conditions

Operating Temperature	-40°C to +125°C
Storage Temperature	-65°C to +150°C
Supply Voltage, $V_{IN}$	2.2V to 7.5V
$V_{SW}$ Voltage	17V
Supply Gamma Buffer, $V_{S+}$	4V to 14V

## Electrical Characteristics

Specifications in standard type face are for  $T_J = 25^\circ\text{C}$  and those with **boldface type** apply over the full **Operating Temperature Range** ( $T_J = -40^\circ\text{C}$  to  $+125^\circ\text{C}$ ). Unless otherwise specified,  $V_{IN} = 2.2\text{V}$  and  $V_{S+} = 8\text{V}$ .

Switching Regulator						
Symbol	Parameter	Conditions	Min <sup>(1)</sup>	Typ <sup>(2)</sup>	Max <sup>(1)</sup>	Units
$I_Q$	Quiescent Current	Not Switching, FSLCT = 0V		1.6	<b>2</b>	mA
		Not Switching, FSLCT = $V_{IN}$		1.65	<b>2.2</b>	
		Switching, FSLCT = 0V		2.5	<b>3</b>	
		Switching, FSLCT = $V_{IN}$		3.4	<b>4</b>	
		Shutdown mode			6	<b>15</b>
$V_{FB}$	Feedback Voltage		<b>1.239</b>	1.265	<b>1.291</b>	V
$\%V_{FB}/\Delta V_{IN}$	Feedback Voltage Line Regulation			0.03	<b>0.05</b>	%/V
$I_{CL}$	Switch Current Limit <sup>(3)</sup>	$V_{IN} = 2.5\text{V}$ , $V_{OUT} = 8\text{V}$		1.4		A
$R_{DSON}$	Switch $R_{DSON}$ <sup>(4)</sup>	$V_{IN} = 2.7\text{V}$		170		m $\Omega$
$I_B$	FB Pin Bias Current <sup>(5)</sup>			30	<b>90</b>	nA
$V_{IN}$	Input Voltage Range		<b>2.2</b>		<b>7.5</b>	V
$I_{SS}$	Soft Start Current		<b>5</b>	11	<b>15</b>	$\mu\text{A}$
$T_{SS}$	Internal Soft Start Ramp Time	FSLCT = 0V		6.7	<b>12</b>	mS
$g_m$	Error Amp Transconductance	$\Delta I = 5\mu\text{A}$	<b>60</b>	135	<b>250</b>	$\mu\text{mho}$

- (1) All limits ensured at room temperature (standard typeface) and at temperature extremes (bold typeface). All room temperature limits are 100% production tested or ensured through statistical analysis. All limits at temperature extremes are specified via correlation using standard Statistical Quality Control (SQC) methods. All limits are used to calculate Average Outgoing Quality Level (AOQL).
- (2) Typical numbers are at 25°C and represent the most likely norm.
- (3) Duty cycle affects current limit due to ramp generator. See Switch Current Limit vs.  $V_{IN}$  and Switch Current Limit vs. Temperature graphs in the Typical Performance Characteristics section.
- (4) See Typical Performance Characteristics section for Tri-Temperature data for  $R_{DSON}$  vs.  $V_{IN}$ .
- (5) Bias current flows into FB pin.

## Electrical Characteristics (continued)

Specifications in standard type face are for  $T_J = 25^\circ\text{C}$  and those with **boldface type** apply over the full **Operating Temperature Range** ( $T_J = -40^\circ\text{C}$  to  $+125^\circ\text{C}$ ). Unless otherwise specified,  $V_{IN} = 2.2\text{V}$  and  $V_{S+} = 8\text{V}$ .

Switching Regulator						
Symbol	Parameter	Conditions	Min <sup>(1)</sup>	Typ <sup>(2)</sup>	Max <sup>(1)</sup>	Units
$A_V$	Error Amp Voltage Gain			135		V/V
$D_{MAX}$	Maximum Duty Cycle		<b>78</b>	85		%
$f_S$	Switching Frequency	FSLCT = 0V	<b>500</b>	600	<b>700</b>	kHz
		FSLCT = $V_{IN}$	<b>0.9</b>	1.25	<b>1.5</b>	MHz
$I_L$	Switch Leakage Current	$V_{SW} = 17\text{V}$		0.185	<b>20</b>	$\mu\text{A}$
$\overline{\text{SHDN}}$	$\overline{\text{SHDN}}$ Threshold	Output High	<b>0.85</b>	0.6		V
		Output Low		0.6	<b>0.3</b>	V
$I_{\overline{\text{SHDN}}}$	Shutdown Pin Current	$0\text{V} \leq \overline{\text{SHDN}} \leq V_{IN}$		0.5	<b>1</b>	$\mu\text{A}$
UVP	On Threshold		<b>1.8</b>	1.9	<b>2</b>	V
	Off Threshold		<b>1.7</b>	1.8	<b>1.9</b>	V
	Hysteresis			100		mV

## Electrical Characteristics

Specifications in standard type face are for  $T_J = 25^\circ\text{C}$  and those with **boldface type** apply over the full **Operating Temperature Range** ( $T_J = -40^\circ\text{C}$  to  $+125^\circ\text{C}$ ). Unless otherwise specified,  $V_{IN} = 2.2\text{V}$  and  $V_{S+} = 8\text{V}$ .

BUFFERS						
Symbol	Parameter	Conditions	Min <sup>(1)</sup>	Typ <sup>(2)</sup>	Max <sup>(1)</sup>	Units
$V_{OS}$	Input offset voltage			2.5	10	mV
$\Delta V_{OS}/\Delta T$	Offset Voltage Drift			8		$\mu\text{V}/^\circ\text{C}$
$I_B$	Input Bias Current			170	<b>800</b>	nA
CMVR	Input Common-mode Voltage Range		0.05		$V_{S+} - 0.05$	V
$Z_{IN}$	Input Impedance			400		k $\Omega$
$C_{IN}$	Input Capacitance			1		pF
$I_{OUT}$	Continuous Output Current	$V_{S+} = 8\text{V}$ , Source	<b>30</b>	39	<b>47</b>	mA
		$V_{S+} = 8\text{V}$ , Sink	<b>-45</b>	-37	<b>-27</b>	
		$V_{S+} = 12\text{V}$ , Source	<b>35</b>	48	<b>59</b>	
		$V_{S+} = 12\text{V}$ , Sink	<b>-54</b>	-44	<b>-32</b>	
$V_{OUT}$ Swing		$R_L = 10\text{k}$ , $V_o$ min.			<b>0.075</b>	V
		$R_L = 10\text{k}$ , $V_o$ max.	<b>7.88</b>			
		$R_L = 2\text{k}$ , $V_o$ min.			<b>0.075</b>	
		$R_L = 2\text{k}$ , $V_o$ max.	<b>7.85</b>			
$A_{VCL}$	Voltage Gain	$R_L = 2\text{ k}\Omega$	<b>0.994</b>	0.998		V/V
		$R_L = 10\text{ k}\Omega$	<b>0.9985</b>	0.9999		
NL	Gain Linearity	$R_L = 2\text{ k}\Omega$ , Buffer input = 0.5 to $(V_{S+} - 0.5\text{V})$		0.01		%
$V_{S+}$	Supply Voltage		<b>4</b>		<b>12</b>	V
PSRR	Power Supply Rejection Ratio	$V_{S+} = 4$ to $12\text{V}$		90	<b>316</b>	$\mu\text{V}/\text{V}$
$I_{S+}$	Supply Current/Amplifier	$V_o = V_{S+}/2$ , No Load		0.75	<b>1.2</b>	mA
SR	Slew Rate	$C_L = 150\text{pF}$		5.3		V/ $\mu\text{s}$
BW	Bandwidth	-3dB, $R_L = 10\text{ k}\Omega$ , $C_L = 100\text{pF}$		3		MHz
$\Phi_M$	Phase Margin	$C_L = 100\text{pF}$		78		Deg $^\circ$

- (1) All limits ensured at room temperature (standard typeface) and at temperature extremes (bold typeface). All room temperature limits are 100% production tested or ensured through statistical analysis. All limits at temperature extremes are specified via correlation using standard Statistical Quality Control (SQC) methods. All limits are used to calculate Average Outgoing Quality Level (AOQL).
- (2) Typical numbers are at  $25^\circ\text{C}$  and represent the most likely norm.

Typical Performance Characteristics

Efficiency vs. Load Current ( $V_{OUT} = 8V, f_S = 600\text{ kHz}$ )

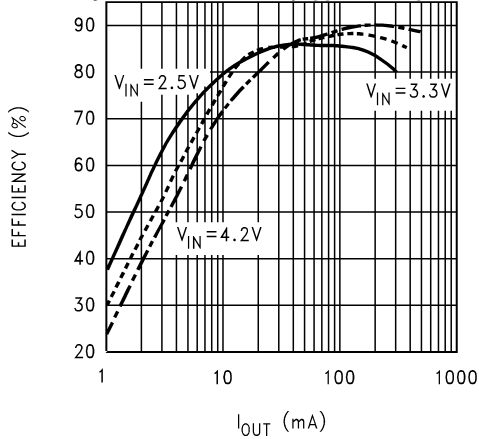


Figure 2.

Efficiency vs. Load Current ( $V_{OUT} = 8V, f_S = 1.25\text{ MHz}$ )

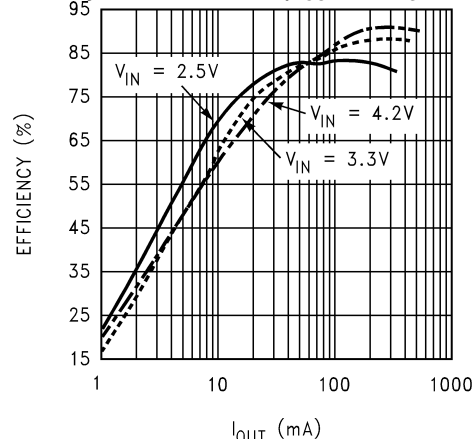


Figure 3.

Efficiency vs. Load Current ( $V_{OUT} = 10V, f_S = 1.25\text{ MHz}$ )

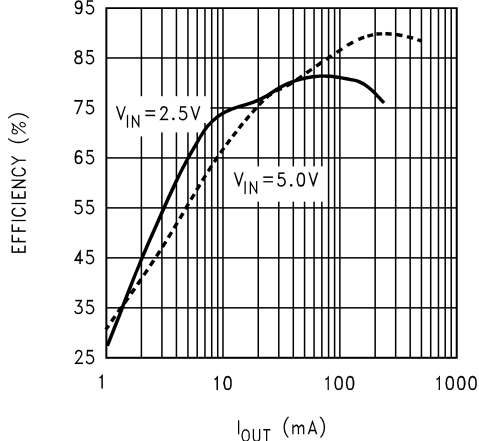


Figure 4.

Switch Current Limit vs. Temperature ( $V_{OUT} = 8V$ )

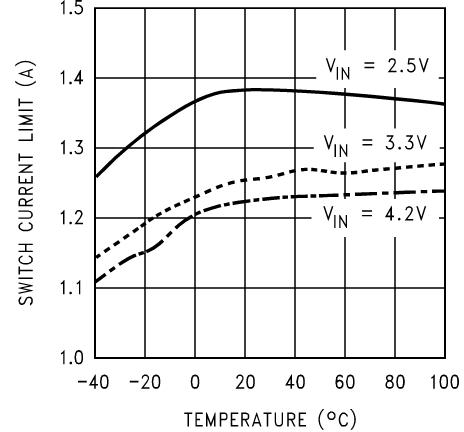


Figure 5.

Switch Current Limit vs.  $V_{IN}$

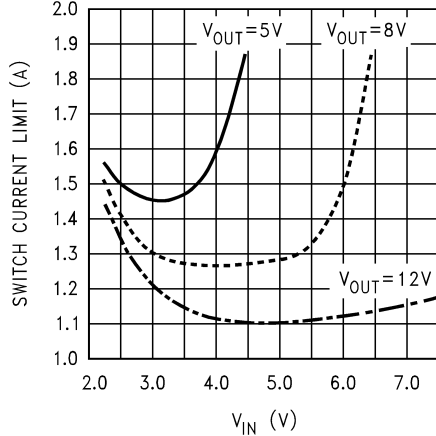


Figure 6.

$R_{DS(on)}$  vs.  $V_{IN}$  ( $I_{SW} = 1A$ )

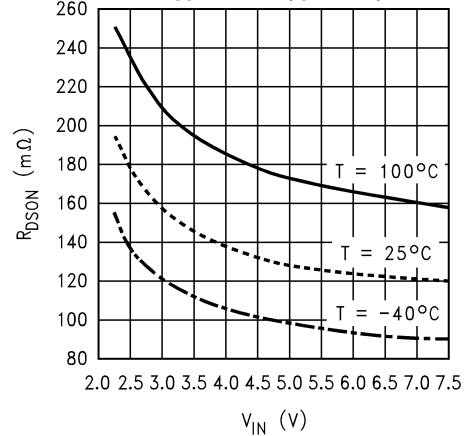


Figure 7.

Typical Performance Characteristics (continued)

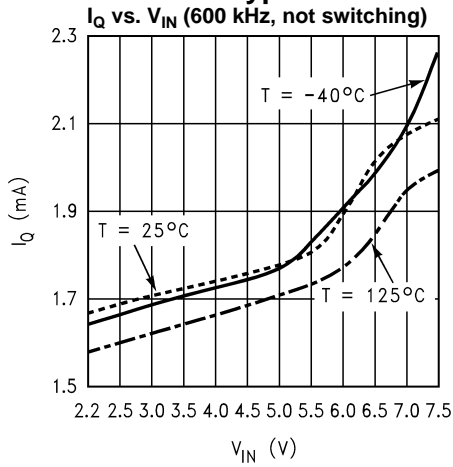


Figure 8.

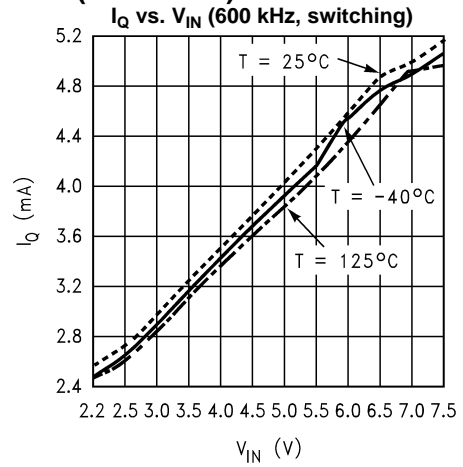


Figure 9.

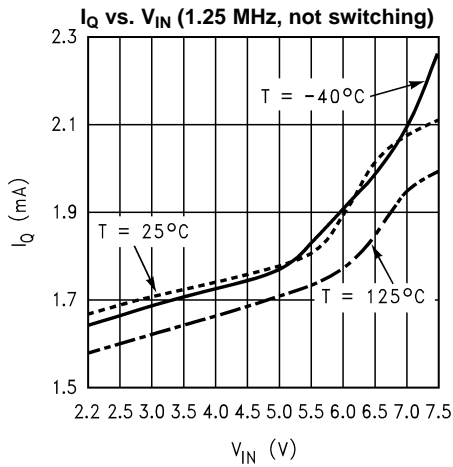


Figure 10.

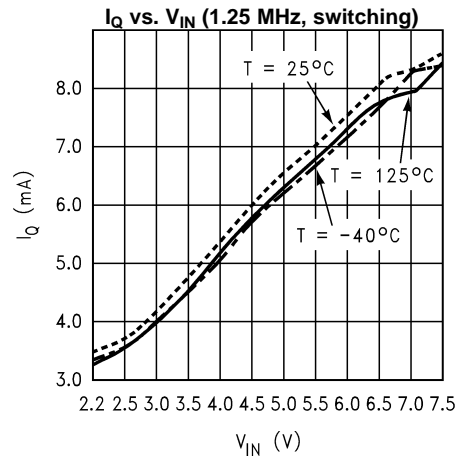


Figure 11.

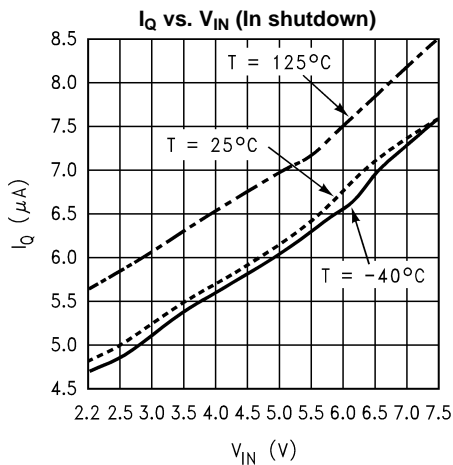


Figure 12.

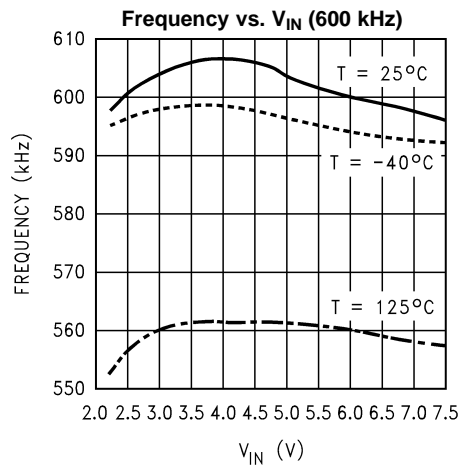


Figure 13.

Typical Performance Characteristics (continued)

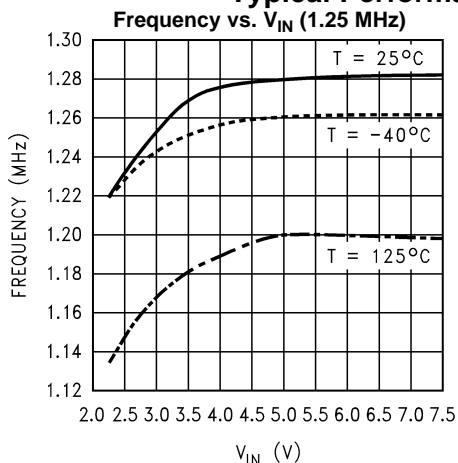


Figure 14.

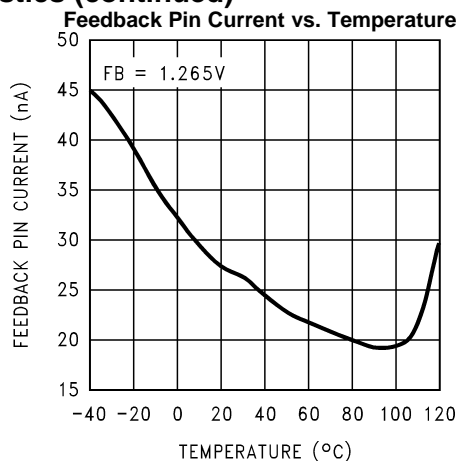


Figure 15.

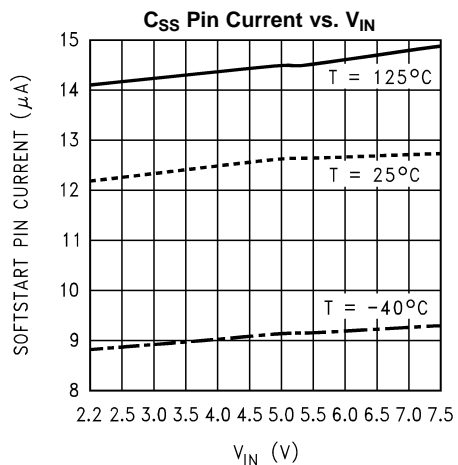
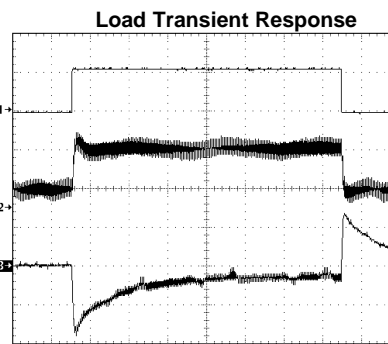
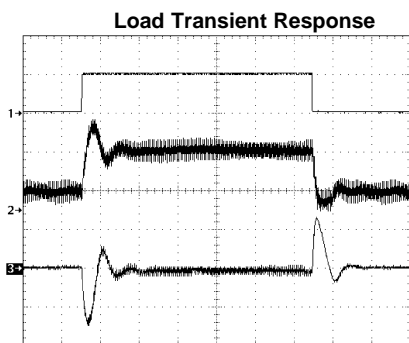


Figure 16.



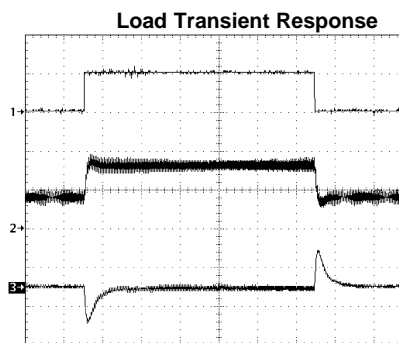
$V_{OUT} = 8V$ ,  $V_{IN} = 3V$ ,  $F = 1.25MHz$   
 1. Load, 80mA to 260mA to 80mA  
 2.  $I_L$ , 500mA/div, DC  
 3.  $V_{OUT}$ , 100mV/div, AC  
 $T = 100\mu s/div$

Figure 17.



$V_{OUT} = 8V$ ,  $V_{IN} = 3V$ ,  $F = 600kHz$   
 1. Load, 80mA to 260mA to 80mA  
 2.  $I_L$ , 500mA/div, DC  
 3.  $V_{OUT}$ , 200mV/div, AC  
 $T = 100\mu s/div$

Figure 18.

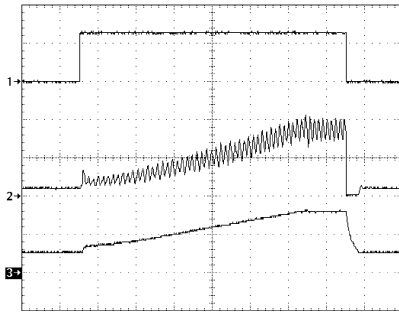


$V_{OUT} = 10V$ ,  $V_{IN} = 5V$ ,  $F = 1.25MHz$   
 1. Load, 195mA to 385mA to 195mA  
 2.  $I_L$ , 500mA/div, DC  
 3.  $V_{OUT}$ , 500mV/div, AC  
 $T = 100\mu s/div$

Figure 19.

**Typical Performance Characteristics (continued)**

**Internal Soft Start**



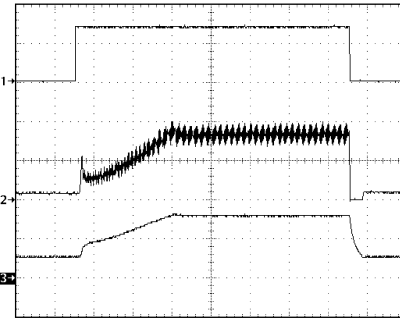
$V_{OUT} = 8V$ ,  $V_{IN} = 3V$ ,  $R_{LOAD} = 27\Omega$ ,  $C_{SS} = \text{none}$ ,  $F = 600\text{kHz}$

1. SHDN, 1V/div, DC
2.  $I_L$ , 500mA/div, DC
3.  $V_{OUT}$ , 5V/div, DC

T = 1ms/div

**Figure 20.**

**Internal Soft Start**



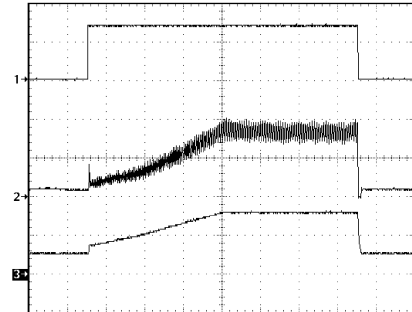
$V_{OUT} = 8V$ ,  $V_{IN} = 3V$ ,  $R_{LOAD} = 27\Omega$ ,  $C_{SS} = \text{none}$ ,  $F = 1.25\text{MHz}$

1. SHDN, 1V/div, DC
2.  $I_L$ , 500mA/div, DC
3.  $V_{OUT}$ , 5V/div, DC

T = 1ms/div

**Figure 21.**

**External Soft Start**



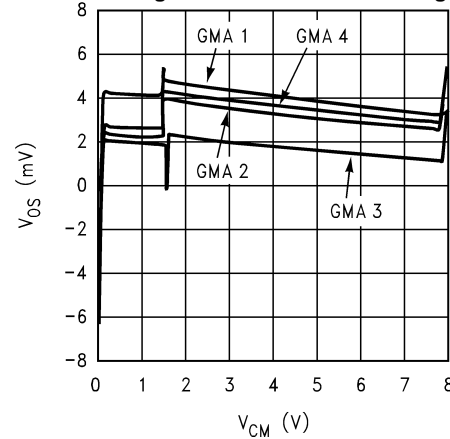
$V_{OUT} = 8V$ ,  $V_{IN} = 3V$ ,  $R_{LOAD} = 27\Omega$ ,  $C_{SS} = 330\text{nF}$ ,  $F = 1.25\text{MHz}$

1. SHDN, 1V/div, DC
2.  $I_L$ , 500mA/div, DC
3.  $V_{OUT}$ , 5V/div, DC

T = 4ms/div

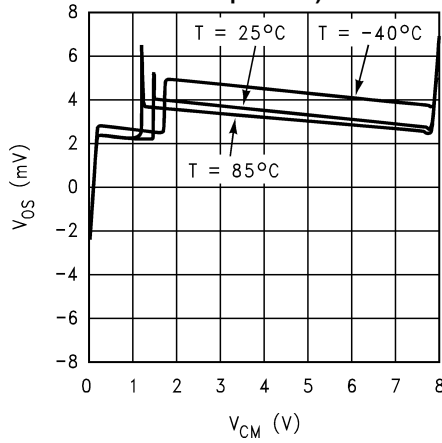
**Figure 22.**

**Input Offset Voltage vs. Common Mode Voltage (3 units)**



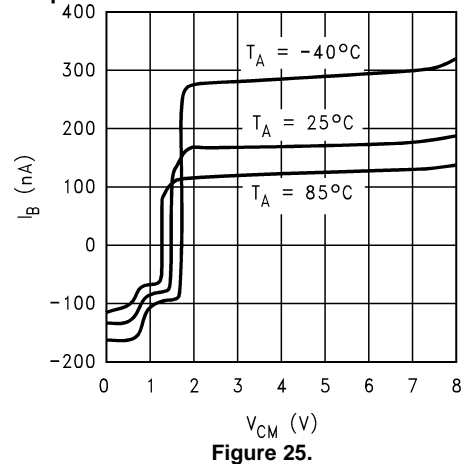
**Figure 23.**

**Input Offset Voltage vs. Common Mode Voltage (Over Temperature)**



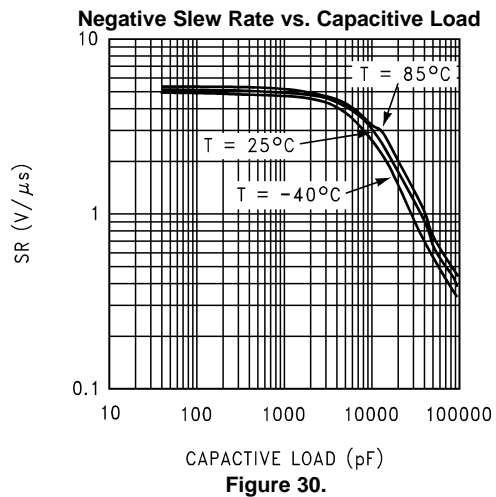
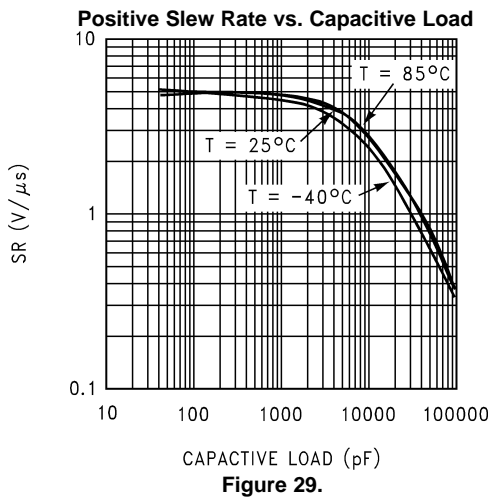
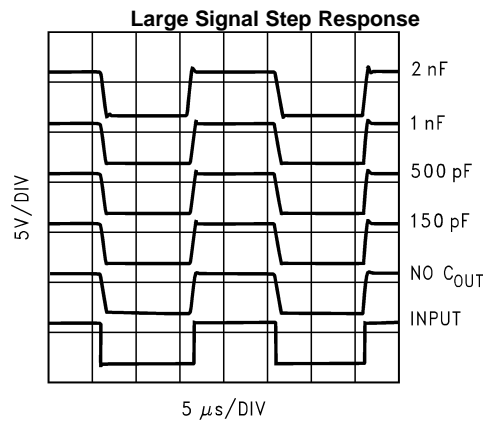
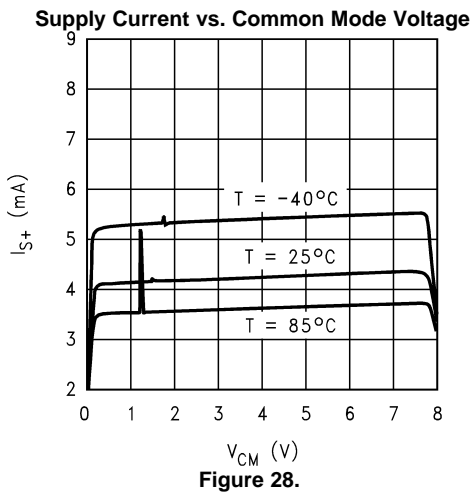
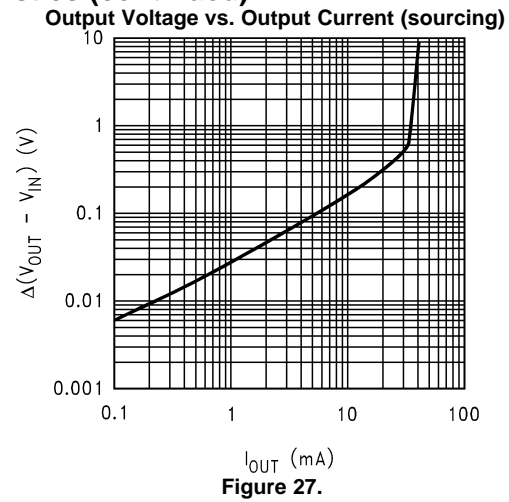
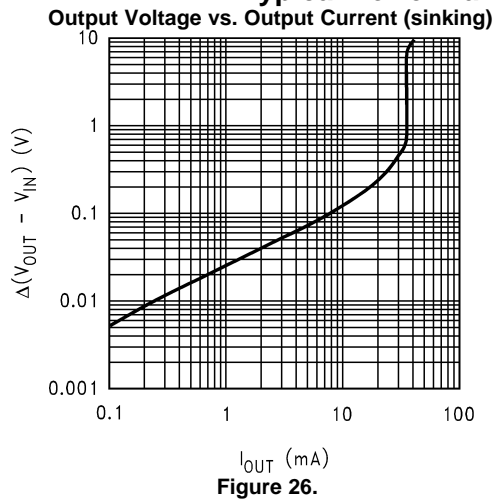
**Figure 24.**

**Input Bias Current vs. Common Mode Voltage**

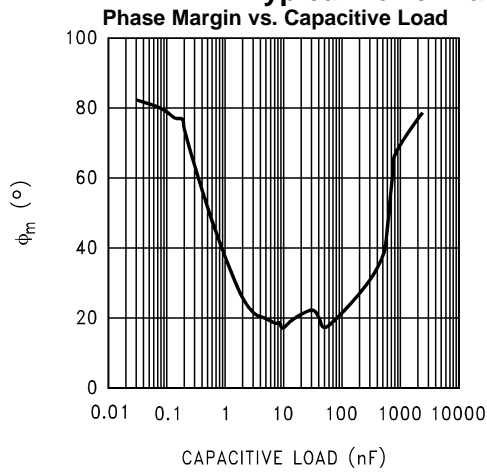


**Figure 25.**

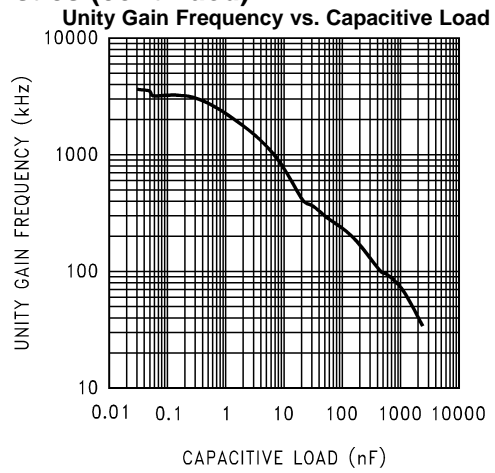
Typical Performance Characteristics (continued)



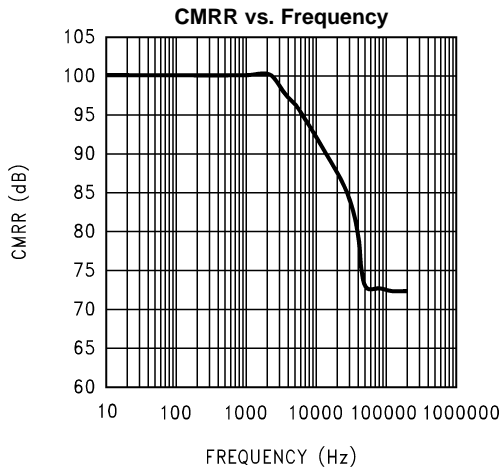
**Typical Performance Characteristics (continued)**



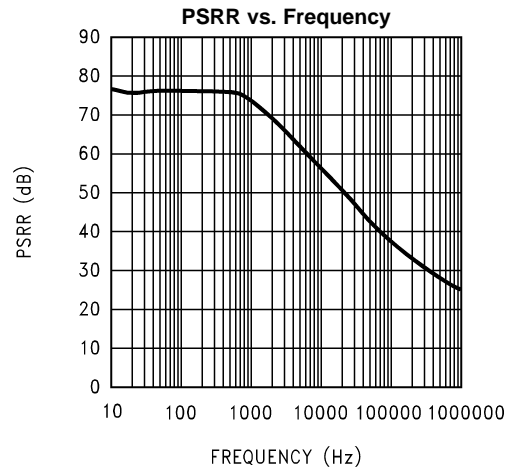
**Figure 31.**



**Figure 32.**

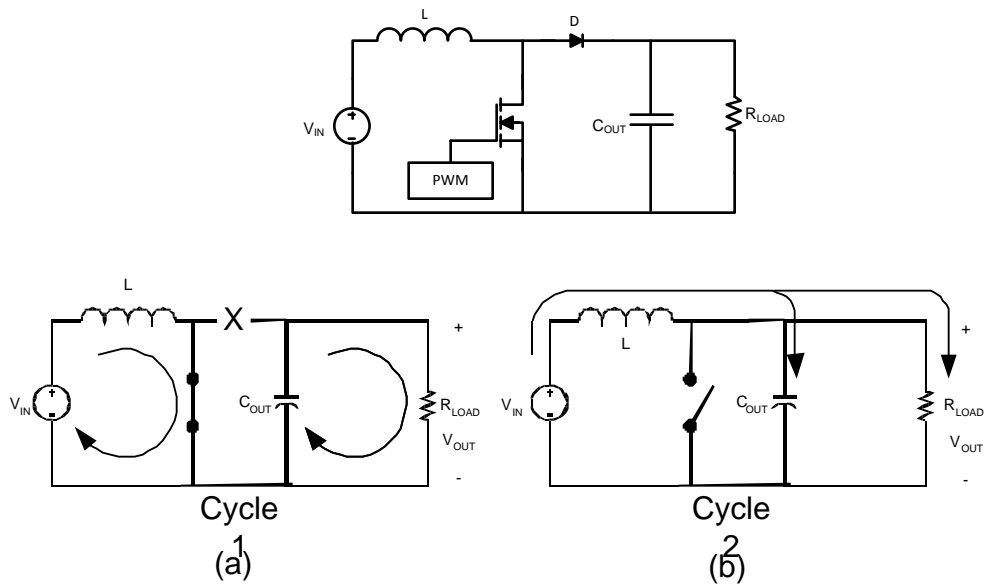


**Figure 33.**



**Figure 34.**

**OPERATION**



**Figure 35. Simplified Boost Converter Diagram  
(a) First Cycle of Operation (b) Second Cycle Of Operation**

**CONTINUOUS CONDUCTION MODE**

The LM3211 is a current-mode, PWM boost regulator. A boost regulator steps the input voltage up to a higher output voltage. In continuous conduction mode (when the inductor current never reaches zero at steady state), the boost regulator operates in two cycles.

In the first cycle of operation, shown in Figure 35 (a), the transistor is closed and the diode is reverse biased. Energy is collected in the inductor and the load current is supplied by C<sub>OUT</sub>.

The second cycle is shown in Figure 35 (b). During this cycle, the transistor is open and the diode is forward biased. The energy stored in the inductor is transferred to the load and output capacitor.

The ratio of these two cycles determines the output voltage. The output voltage is defined approximately as:

$$V_{OUT} = \frac{V_{IN}}{1-D} , D' = (1-D) = \frac{V_{IN}}{V_{OUT}} \tag{2}$$

where D is the duty cycle of the switch, D and D' will be required for design calculations

**SETTING THE OUTPUT VOLTAGE**

The output voltage is set using the feedback pin and a resistor divider connected to the output as shown in the typical operating circuit. The feedback pin voltage is 1.265V, so the ratio of the feedback resistors sets the output voltage according to the following equation:

$$R1 = R2 \left( \frac{V_{OUT}}{1.265V} - 1 \right) \tag{3}$$

## SOFT-START CAPACITOR

The LM3211 has patented internal circuitry that is used to limit the inductor inrush current on start-up. This inrush current limiting circuitry serves as a soft-start. However, many applications may require much more soft-start than what is available with the internal circuitry. The external SS pin is used to tailor the soft-start for a specific application. A  $11\mu\text{A}$  current charges the external soft-start capacitor,  $C_{\text{SS}}$ . The soft-start time can be estimated as:

$$T_{\text{SS}} = C_{\text{SS}} \cdot 0.6\text{V} / 11\mu\text{A} \quad (4)$$

The minimum soft-start time is set by the internal soft-start circuitry, typically 7ms for 600kHz operation and approximately half that for 1.25MHz operation. Only longer soft-start times may be implemented using the SS pin and a capacitor  $C_{\text{SS}}$ . If a shorter time is designed for using the above equation, the internal soft-start circuitry will override it.

Due to the unique nature of the dual internal/external softstart, care was taken in the design to ensure temperature stable operation. As you can see with the  $I_{\text{SS}}$  data in the Electrical Characteristic table and the graph "Soft-Start Current vs.  $V_{\text{IN}}$ " in the [Typical Performance Characteristics](#) section, the soft start current has a temperature coefficient and would lead one to believe there would be significant variation with temperature. Though the current has a temperature coefficient the actual programmed external soft start time does not show this extreme of a temperature variation. As you can see in the following transient plots:

$V_{\text{OUT}} = 8\text{V}$ ,  $V_{\text{IN}} = 2.5\text{V}$ ,  $R_{\text{L}} = 27\Omega$ ,  $C_{\text{SS}} = 330\text{nF}$ ,  $T = 4\text{ms/div}$ ,  $F = 1.25\text{MHz}$ .

Trace:

1.  $\overline{\text{SHDN}}$ , 1V/div, DC Coupled
2.  $I_{\text{L}}$ , 0.5A/div, DC Coupled
3.  $V_{\text{OUT}}$ , 5V/div, DC Coupled

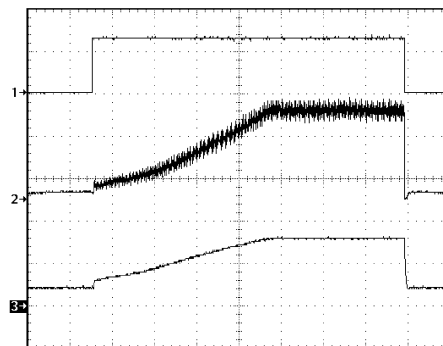


Figure 36.  $T_{\text{A}} = -20^{\circ}\text{C}$

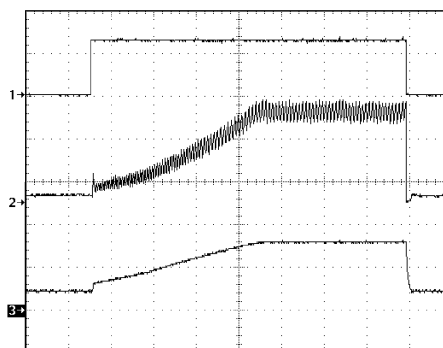


Figure 37.  $T_{\text{A}} = 27^{\circ}\text{C}$

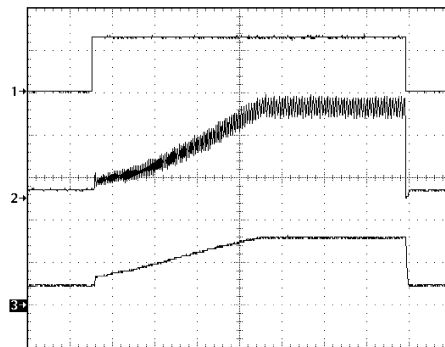


Figure 38.  $T_A = 85^\circ\text{C}$

When programming the softstart time externally, simply use the equation given in the [SOFT-START CAPACITOR](#) section above. This equation uses the typical room temperature value of the soft start current, 11 $\mu\text{A}$ , to set the soft start time.

### INTRODUCTION TO COMPENSATION

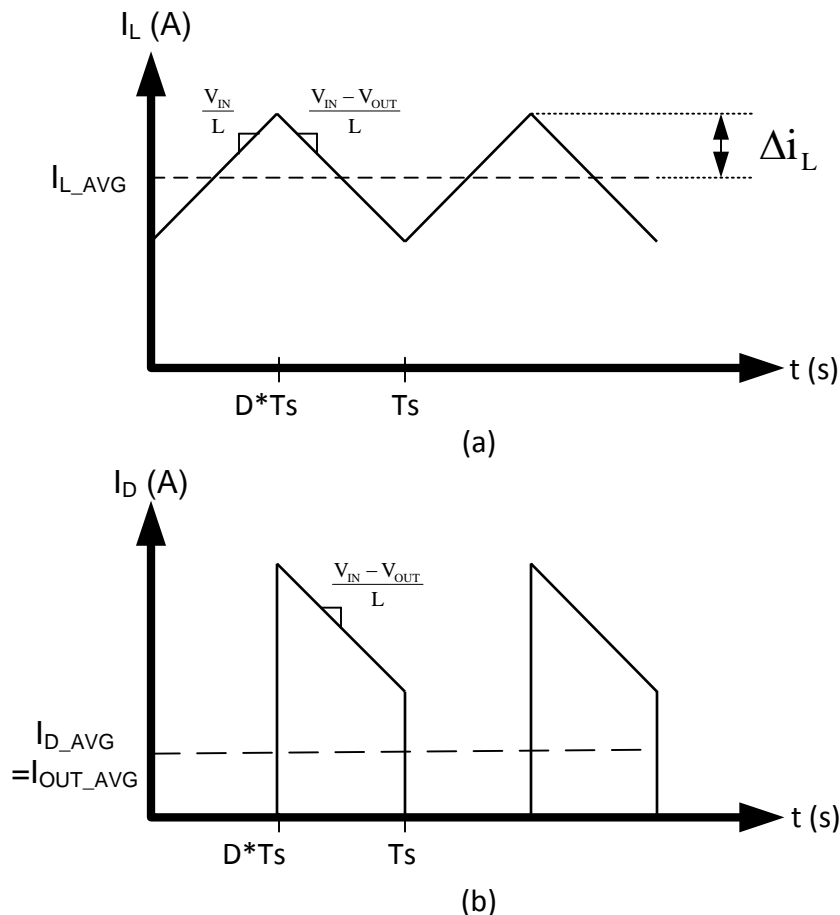


Figure 39. (a) Inductor current. (b) Diode current.

The LM3211 is a current mode PWM boost converter. The signal flow of this control scheme has two feedback loops, one that senses switch current and one that senses output voltage.

To keep a current programmed control converter stable above duty cycles of 50%, the inductor must meet certain criteria. The inductor, along with input and output voltage, will determine the slope of the current through the inductor (see [Figure 39 \(a\)](#)). If the slope of the inductor current is too great, the circuit will be unstable above duty cycles of 50%. A 10µH inductor is recommended for most 600 kHz applications, while a 4.7µH inductor may be used for most 1.25 MHz applications. If the duty cycle is approaching the maximum of 85%, it may be necessary to increase the inductance by as much as 2X. See [INDUCTOR AND DIODE SELECTION](#) for more detailed inductor sizing.

The LM3211 provides a compensation pin ( $V_C$ ) to customize the voltage loop feedback. It is recommended that a series combination of  $R_C$  and  $C_C$  be used for the compensation network, as shown in the typical application circuit. For any given application, there exists a unique combination of  $R_C$  and  $C_C$  that will optimize the performance of the LM3211 circuit in terms of its transient response. The series combination of  $R_C$  and  $C_C$  introduces a pole-zero pair according to the following equations:

$$f_{zC} = \frac{1}{2\pi R_C C_C} \text{ Hz} \quad (5)$$

$$f_{pC} = \frac{1}{2\pi(R_C + R_O)C_C} \text{ Hz} \quad (6)$$

where  $R_O$  is the output impedance of the error amplifier, approximately 1MΩ. For most applications, performance can be optimized by choosing values within the range  $5k\Omega \leq R_C \leq 60k\Omega$  ( $R_C$  can be up to 200kΩ if  $C_{C2}$  is used, see [HIGH OUTPUT CAPACITOR ESR COMPENSATION](#)) and  $680pF \leq C_C \leq 4.7nF$ . Refer to the [Application Information](#) section for recommended values for specific circuits and conditions. Refer to the [Compensation](#) section for other design requirement.

## COMPENSATION FOR BOOST DC/DC

This section will present a general design procedure to help insure a stable and operational circuit. The designs in this datasheet are optimized for particular requirements. If different conversions are required, some of the components may need to be changed to ensure stability. Below is a set of general guidelines in designing a stable circuit for continuous conduction operation, in most all cases this will provide for stability during discontinuous operation as well. The power components and their effects will be determined first, then the compensation components will be chosen to produce stability.

## INDUCTOR AND DIODE SELECTION

Although the inductor sizes mentioned earlier are fine for most applications, a more exact value can be calculated. To ensure stability at duty cycles above 50%, the inductor must have some minimum value determined by the minimum input voltage and the maximum output voltage. This equation is:

$$L > \frac{V_{IN} R_{DS(ON)}}{0.144 f_s} \left[ \frac{\left(\frac{D}{D'}\right)^2 - 1}{\left(\frac{D}{D'}\right) + 1} \right] \text{ (in H)} \quad (7)$$

where  $f_s$  is the switching frequency,  $D$  is the duty cycle, and  $R_{DS(ON)}$  is the ON resistance of the internal switch taken from the graph " $R_{DS(ON)}$  vs.  $V_{IN}$ " in the *Typical Performance Characteristics* section. This equation is only good for duty cycles greater than 50% ( $D > 0.5$ ), for duty cycles less than 50% the recommended values may be used. The corresponding inductor current ripple as shown in [Figure 39 \(a\)](#) is given by:

$$\Delta i_L = \frac{V_{IN} D}{2L f_s} \text{ (in Amps)} \quad (8)$$

The inductor ripple current is important for a few reasons. One reason is because the peak switch current will be the average inductor current (input current or  $I_{LOAD}/D'$ ) plus  $\Delta i_L$ . As a side note, discontinuous operation occurs when the inductor current falls to zero during a switching cycle, or  $\Delta i_L$  is greater than the average inductor current. Therefore, continuous conduction mode occurs when  $\Delta i_L$  is less than the average inductor current. Care must be taken to make sure that the switch will not reach its current limit during normal operation. The inductor must also be sized accordingly. It should have a saturation current rating higher than the peak inductor current expected. The output voltage ripple is also affected by the total ripple current.

The output diode for a boost regulator must be chosen correctly depending on the output voltage and the output current. The typical current waveform for the diode in continuous conduction mode is shown in [Figure 39 \(b\)](#). The diode must be rated for a reverse voltage equal to or greater than the output voltage used. The average current rating must be greater than the maximum load current expected, and the peak current rating must be greater than the peak inductor current. During short circuit testing, or if short circuit conditions are possible in the application, the diode current rating must exceed the switch current limit. Using Schottky diodes with lower forward voltage drop will decrease power dissipation and increase efficiency.

## DC GAIN AND OPEN-LOOP GAIN

Since the control stage of the converter forms a complete feedback loop with the power components, it forms a closed-loop system that must be stabilized to avoid positive feedback and instability. A value for open-loop DC gain will be required, from which you can calculate, or place, poles and zeros to determine the crossover frequency and the phase margin. A high phase margin (greater than 45°) is desired for the best stability and transient response. For the purpose of stabilizing the LM3211, choosing a crossover point well below where the right half plane zero is located will ensure sufficient phase margin. A discussion of the right half plane zero and checking the crossover using the DC gain will follow.

## INPUT AND OUTPUT CAPACITOR SELECTION

The switching action of a boost regulator causes a triangular voltage waveform at the input. A capacitor is required to reduce the input ripple and noise for proper operation of the regulator. The size used is dependant on the application and board layout. If the regulator will be loaded uniformly, with very little load changes, and at lower current outputs, the input capacitor size can often be reduced. The size can also be reduced if the input of the regulator is very close to the source output. The size will generally need to be larger for applications where the regulator is supplying nearly the maximum rated output or if large load steps are expected. A minimum value of 10µF should be used for the less stressful conditions while a 22µF to 47µF capacitor may be required for higher power and dynamic loads. Larger values and/or lower ESR may be needed if the application requires very low ripple on the input source voltage.

The choice of output capacitors is also somewhat arbitrary and depends on the design requirements for output voltage ripple. It is recommended that low ESR (Equivalent Series Resistance, denoted  $R_{ESR}$ ) capacitors be used such as ceramic, polymer electrolytic, or low ESR tantalum. Higher ESR capacitors may be used but will require more compensation which will be explained later on in the section. The ESR is also important because it determines the peak to peak output voltage ripple according to the approximate equation:

$$\Delta V_{OUT} \approx 2\Delta i_L R_{ESR} \text{ (in Volts)} \quad (9)$$

A minimum value of 10µF is recommended and may be increased to a larger value. After choosing the output capacitor you can determine a pole-zero pair introduced into the control loop by the following equations:

$$f_{P1} = \frac{1}{2\pi(R_{ESR} + R_L)C_{OUT}} \text{ (in Hz)} \quad (10)$$

$$f_{Z1} = \frac{1}{2\pi R_{ESR} C_{OUT}} \text{ (in Hz)} \quad (11)$$

Where  $R_L$  is the minimum load resistance corresponding to the maximum load current. The zero created by the ESR of the output capacitor is generally very high frequency if the ESR is small. If low ESR capacitors are used it can be neglected. If higher ESR capacitors are used see the [HIGH OUTPUT CAPACITOR ESR COMPENSATION](#) section.

## RIGHT HALF PLANE ZERO

A current mode control boost regulator has an inherent right half plane zero (RHP zero). This zero has the effect of a zero in the gain plot, causing an imposed +20dB/decade on the rolloff, but has the effect of a pole in the phase, subtracting another 90° in the phase plot. This can cause undesirable effects if the control loop is influenced by this zero. To ensure the RHP zero does not cause instability issues, the control loop should be designed to have a bandwidth of less than ½ the frequency of the RHP zero. This zero occurs at a frequency of:

$$\text{RHPzero} = \frac{V_{OUT}(D')^2}{2\pi I_{LOAD} L} \text{ (in Hz)} \quad (12)$$

where  $I_{LOAD}$  is the maximum load current.

## SELECTING THE COMPENSATION COMPONENTS

The first step in selecting the compensation components  $R_C$  and  $C_C$  is to set a dominant low frequency pole in the control loop. Simply choose values for  $R_C$  and  $C_C$  within the ranges given in the [INTRODUCTION TO COMPENSATION](#) section to set this pole in the area of 10Hz to 500Hz. The frequency of the pole created is determined by the equation:

$$f_{PC} = \frac{1}{2\pi(R_C + R_O)C_C} \quad (\text{in Hz}) \quad (13)$$

where  $R_O$  is the output impedance of the error amplifier, approximately 1M $\Omega$ . Since  $R_C$  is generally much less than  $R_O$ , it does not have much effect on the above equation and can be neglected until a value is chosen to set the zero  $f_{ZC}$ .  $f_{ZC}$  is created to cancel out the pole created by the output capacitor,  $f_{P1}$ . The output capacitor pole will shift with different load currents as shown by the equation, so setting the zero is not exact. Determine the range of  $f_{P1}$  over the expected loads and then set the zero  $f_{ZC}$  to a point approximately in the middle. The frequency of this zero is determined by:

$$f_{ZC} = \frac{1}{2\pi C_C R_C} \quad (\text{in Hz}) \quad (14)$$

Now  $R_C$  can be chosen with the selected value for  $C_C$ . Check to make sure that the pole  $f_{PC}$  is still in the 10Hz to 500Hz range, change each value slightly if needed to ensure both component values are in the recommended range. After checking the design at the end of this section, these values can be changed a little more to optimize performance if desired. This is best done in the lab on a bench, checking the load step response with different values until the ringing and overshoot on the output voltage at the edge of the load steps is minimal. This should produce a stable, high performance circuit. For improved transient response, higher values of  $R_C$  should be chosen. This will improve the overall bandwidth which makes the regulator respond more quickly to transients. If more detail is required, or the most optimal performance is desired, refer to a more in depth discussion of compensating current mode DC/DC switching regulators.

## HIGH OUTPUT CAPACITOR ESR COMPENSATION

When using an output capacitor with a high ESR value, or just to improve the overall phase margin of the control loop, another pole may be introduced to cancel the zero created by the ESR. This is accomplished by adding another capacitor,  $C_{C2}$ , directly from the compensation pin  $V_C$  to ground, in parallel with the series combination of  $R_C$  and  $C_C$ . The pole should be placed at the same frequency as  $f_{Z1}$ , the ESR zero. The equation for this pole follows:

$$f_{PC2} = \frac{1}{2\pi C_{C2}(R_C // R_O)} \quad (\text{in Hz}) \quad (15)$$

To ensure this equation is valid, and that  $C_{C2}$  can be used without negatively impacting the effects of  $R_C$  and  $C_C$ ,  $f_{PC2}$  must be greater than  $10f_{ZC}$ .

## CHECKING THE DESIGN

The final step is to check the design. This is to ensure a bandwidth of  $\frac{1}{2}$  or less of the frequency of the RHP zero. This is done by calculating the open-loop DC gain,  $A_{DC}$ . After this value is known, you can calculate the crossover visually by placing a  $-20\text{dB/decade}$  slope at each pole, and a  $+20\text{dB/decade}$  slope for each zero. The point at which the gain plot crosses unity gain, or 0dB, is the crossover frequency. If the crossover frequency is less than  $\frac{1}{2}$  the RHP zero, the phase margin should be high enough for stability. The phase margin can also be improved by adding  $C_{C2}$  as discussed earlier in the section. The equation for  $A_{DC}$  is given below with additional equations required for the calculation:

$$A_{DC(\text{DB})} = 20\log_{10} \left\langle \left( \frac{R_{FB2}}{R_{FB1} + R_{FB2}} \right) \frac{g_m R_O D'}{R_{DSON}} \{ [(\omega C_{Leff}) // R_L] // R_L \} \right\rangle \quad (\text{in dB}) \quad (16)$$

$$\omega C \cong \frac{2f_s}{nD'} \quad (\text{in rad/s}) \quad (17)$$

$$L_{eff} = \frac{L}{(D')^2} \quad (18)$$

$$n = 1 + \frac{2mc}{m1} \text{ (no unit)} \quad (19)$$

$$mc \cong 0.072fs \text{ (in V/s)} \quad (20)$$

$$m1 \cong \frac{V_{IN}R_{DSON}}{L} \text{ (in V/s)} \quad (21)$$

where  $R_L$  is the minimum load resistance,  $V_{IN}$  is the maximum input voltage,  $g_m$  is the error amplifier transconductance found in the *Electrical Characteristics* table, and  $R_{DSON}$  is the value chosen from the graph " $R_{DSON}$  vs.  $V_{IN}$ " in the *Typical Performance Characteristics* section.

## BUFFER COMPENSATION

The Gamma buffers in the LM3211 are internally compensated. They will remain stable with no capacitive load while sourcing or sinking current. Any capacitance presented by a load in an application will only provide further stability.

## LAYOUT CONSIDERATIONS

The LM3211 uses two separate ground connections, GND for the driver and NMOS power device of the boost regulator and AGND for the sensitive analog control circuitry of the boost regulator and the  $V_{COM}$  and Gamma buffers. The AGND and GND pins should be tied directly together at the package, see [Figure 40](#) and [Figure 41](#). The feedback, softstart, and compensation networks should be connected directly to a dedicated analog ground plane and this ground plane must connect to the AGND pin, as in [Figure 40](#). If no analog ground plane is available then the ground connections of the feedback, softstart, and compensation networks must tie directly to the AGND pin, as show in [Figure 41](#). Connecting these networks to the GND pin can inject noise into the system and effect performance. For 600kHz operation the FSLCT pin should be tied to an analog ground plane or directly to the AGND pin. For 1.25MHz operation the FSLCT pin should be tied to the  $V_{IN}$  pin.

The input bypass capacitor  $C_{IN}$  must be placed close to the IC. This will reduce copper trace resistance which effects input voltage ripple of the IC. For additional input voltage filtering, a 100nF bypass capacitor can be placed in parallel with  $C_{IN}$ , close to the  $V_{IN}$  pin, to shunt any high frequency noise to ground. The output capacitor,  $C_{OUT}$ , should also be placed close to the IC. Any copper trace connections for the  $C_{OUT}$  capacitor can increase the series resistance, which directly effects output voltage ripple and efficiency. The feedback network, resistors R1 and R2, should be kept close to the FB pin, and away from the inductor, to minimize copper trace connections that can inject noise into the system. Trace connections made to the inductor and schottky diode should be minimized to reduce power dissipation and increase overall efficiency.

The layout of the Gamma buffer traces is important to minimize noise injected into them. Route all input and output traces for the buffers away from the inductor and the high power switching traces used for the boost switcher. For best performance route these traces on the opposite side of the board from the high current switching traces and use a ground plane between the two sides for shielding.

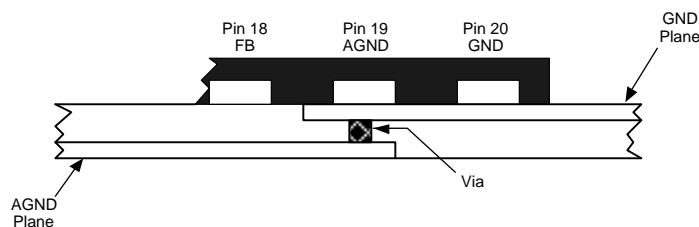


Figure 40. Multi-Layer Layout

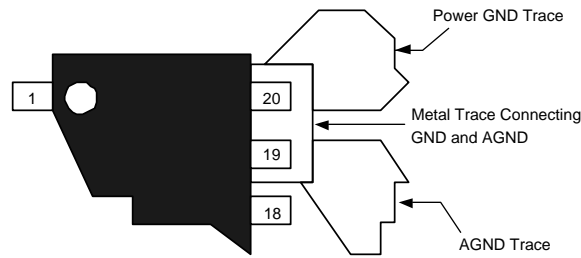


Figure 41. Single Layer Layout

Application Information

Table 1. Some recommended Inductors (others may be used)

Manufacturer	Inductor	Contact Information
Coilcraft	DO3316 series	<a href="http://www.coilcraft.com">www.coilcraft.com</a>
Coiltronics	DRQ73 series	<a href="http://www.cooperet.com">www.cooperet.com</a>
Pulse	P0751 series	<a href="http://www.pulseeng.com">www.pulseeng.com</a>
Sumida	CDRH8D28 series	<a href="http://www.sumida.com">www.sumida.com</a>

Table 2. Some recommended Input and Output Capacitors (others may be used)

Manufacturer	Capacitor	Contact Information
Vishay Sprague	293D, 592D, and 595D series tantalum	<a href="http://www.vishay.com">www.vishay.com</a>
Taiyo Yuden	High capacitance MLCC ceramic	<a href="http://www.t-yuden.com">www.t-yuden.com</a>
Cornell Dubilier	ESRD series Polymer Aluminum Electrolytic SPV and AFK series V-chip series	<a href="http://www.cde.com">www.cde.com</a>
Panasonic	High capacitance MLCC ceramic EEJ-L series tantalum	<a href="http://www.panasonic.com">www.panasonic.com</a>

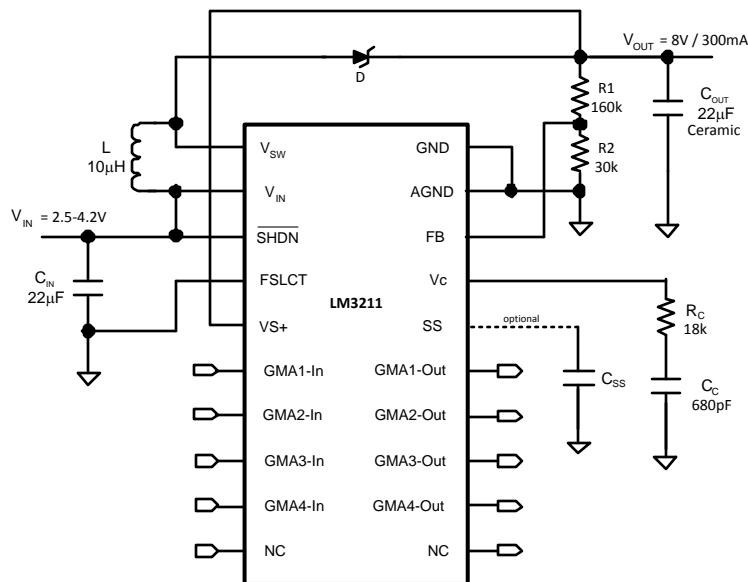


Figure 42. 600kHz, 8V Application

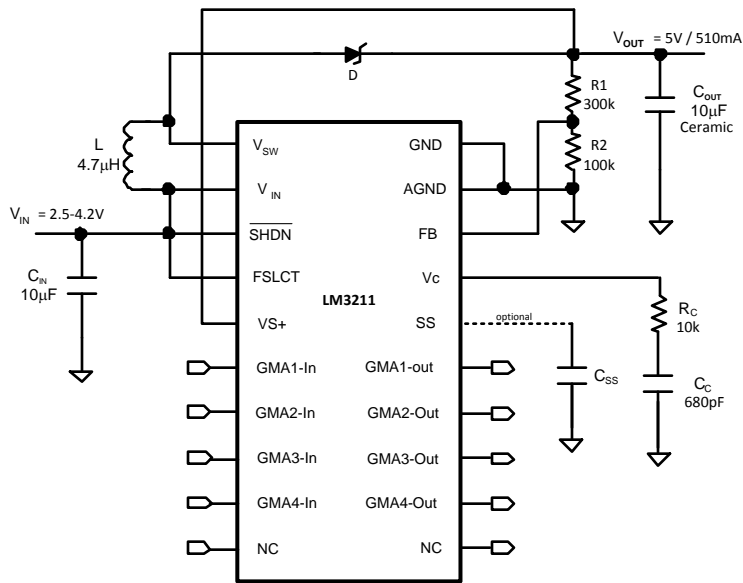


Figure 43. 1.25MHz, 5V Application

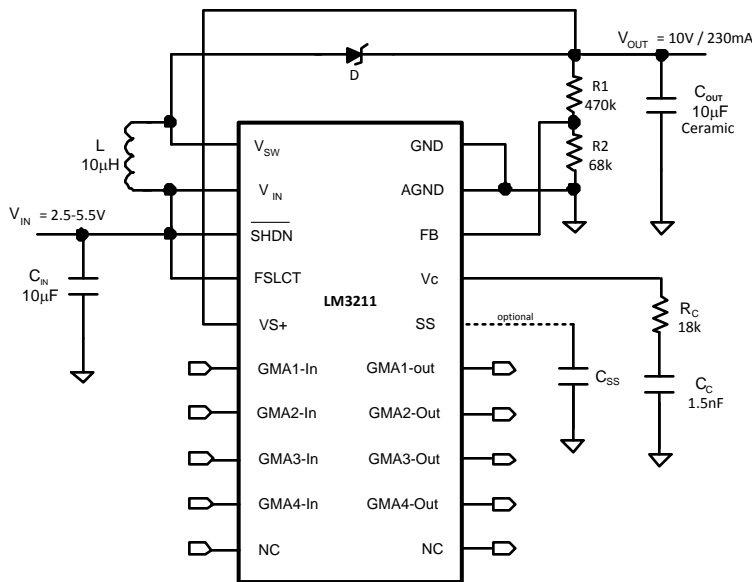


Figure 44. 1.25MHz, 10V Application

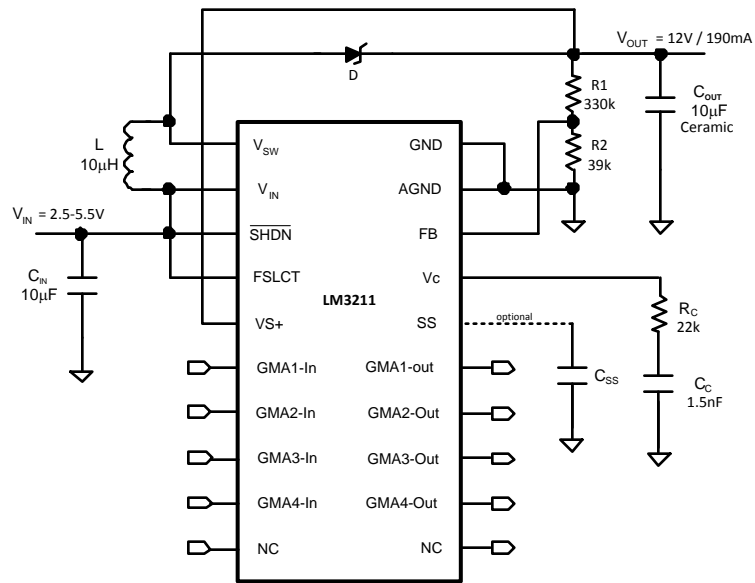


Figure 45. 1.25MHz, 12V Application

---

**REVISION HISTORY**

<b>Changes from Revision A (March 2013) to Revision B</b>	<b>Page</b>
<hr/> <ul style="list-style-type: none"><li>• Changed layout of National Data Sheet to TI format .....</li></ul>	<hr/> <a href="#">22</a>

**PACKAGING INFORMATION**

Orderable Device	Status (1)	Package Type	Package Drawing	Pins	Package Qty	Eco Plan (2)	Lead/Ball Finish (6)	MSL Peak Temp (3)	Op Temp (°C)	Device Marking (4/5)	Samples
LM3211MTX-ADJ/NOPB	ACTIVE	TSSOP	PW	20		TBD	Call TI	Call TI		LM3211 MTADJ	<b>Samples</b>

(1) The marketing status values are defined as follows:

**ACTIVE:** Product device recommended for new designs.

**LIFEBUY:** TI has announced that the device will be discontinued, and a lifetime-buy period is in effect.

**NRND:** Not recommended for new designs. Device is in production to support existing customers, but TI does not recommend using this part in a new design.

**PREVIEW:** Device has been announced but is not in production. Samples may or may not be available.

**OBSELETE:** TI has discontinued the production of the device.

(2) Eco Plan - The planned eco-friendly classification: Pb-Free (RoHS), Pb-Free (RoHS Exempt), or Green (RoHS & no Sb/Br) - please check <http://www.ti.com/productcontent> for the latest availability information and additional product content details.

**TBD:** The Pb-Free/Green conversion plan has not been defined.

**Pb-Free (RoHS):** TI's terms "Lead-Free" or "Pb-Free" mean semiconductor products that are compatible with the current RoHS requirements for all 6 substances, including the requirement that lead not exceed 0.1% by weight in homogeneous materials. Where designed to be soldered at high temperatures, TI Pb-Free products are suitable for use in specified lead-free processes.

**Pb-Free (RoHS Exempt):** This component has a RoHS exemption for either 1) lead-based flip-chip solder bumps used between the die and package, or 2) lead-based die adhesive used between the die and leadframe. The component is otherwise considered Pb-Free (RoHS compatible) as defined above.

**Green (RoHS & no Sb/Br):** TI defines "Green" to mean Pb-Free (RoHS compatible), and free of Bromine (Br) and Antimony (Sb) based flame retardants (Br or Sb do not exceed 0.1% by weight in homogeneous material)

(3) MSL, Peak Temp. - The Moisture Sensitivity Level rating according to the JEDEC industry standard classifications, and peak solder temperature.

(4) There may be additional marking, which relates to the logo, the lot trace code information, or the environmental category on the device.

(5) Multiple Device Markings will be inside parentheses. Only one Device Marking contained in parentheses and separated by a "~" will appear on a device. If a line is indented then it is a continuation of the previous line and the two combined represent the entire Device Marking for that device.

(6) Lead/Ball Finish - Orderable Devices may have multiple material finish options. Finish options are separated by a vertical ruled line. Lead/Ball Finish values may wrap to two lines if the finish value exceeds the maximum column width.

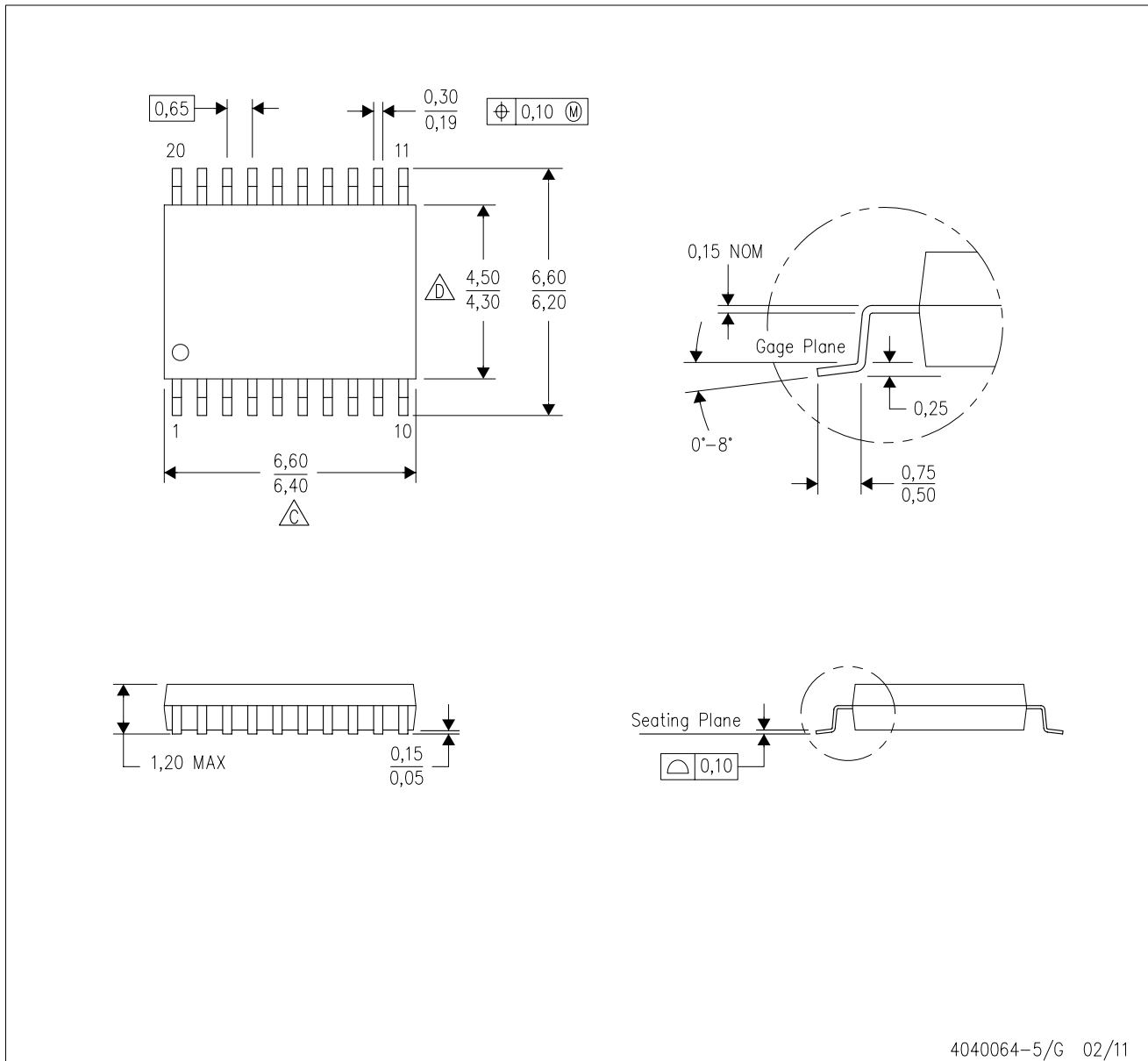
**Important Information and Disclaimer:**The information provided on this page represents TI's knowledge and belief as of the date that it is provided. TI bases its knowledge and belief on information provided by third parties, and makes no representation or warranty as to the accuracy of such information. Efforts are underway to better integrate information from third parties. TI has taken and continues to take reasonable steps to provide representative and accurate information but may not have conducted destructive testing or chemical analysis on incoming materials and chemicals. TI and TI suppliers consider certain information to be proprietary, and thus CAS numbers and other limited information may not be available for release.

In no event shall TI's liability arising out of such information exceed the total purchase price of the TI part(s) at issue in this document sold by TI to Customer on an annual basis.



PW (R-PDSO-G20)

PLASTIC SMALL OUTLINE



4040064-5/G 02/11

- NOTES:
- A. All linear dimensions are in millimeters. Dimensioning and tolerancing per ASME Y14.5M-1994.
  - B. This drawing is subject to change without notice.
  - C. Body length does not include mold flash, protrusions, or gate burrs. Mold flash, protrusions, or gate burrs shall not exceed 0,15 each side.
  - D. Body width does not include interlead flash. Interlead flash shall not exceed 0,25 each side.
  - E. Falls within JEDEC MO-153

## IMPORTANT NOTICE

Texas Instruments Incorporated and its subsidiaries (TI) reserve the right to make corrections, enhancements, improvements and other changes to its semiconductor products and services per JESD46, latest issue, and to discontinue any product or service per JESD48, latest issue. Buyers should obtain the latest relevant information before placing orders and should verify that such information is current and complete. All semiconductor products (also referred to herein as "components") are sold subject to TI's terms and conditions of sale supplied at the time of order acknowledgment.

TI warrants performance of its components to the specifications applicable at the time of sale, in accordance with the warranty in TI's terms and conditions of sale of semiconductor products. Testing and other quality control techniques are used to the extent TI deems necessary to support this warranty. Except where mandated by applicable law, testing of all parameters of each component is not necessarily performed.

TI assumes no liability for applications assistance or the design of Buyers' products. Buyers are responsible for their products and applications using TI components. To minimize the risks associated with Buyers' products and applications, Buyers should provide adequate design and operating safeguards.

TI does not warrant or represent that any license, either express or implied, is granted under any patent right, copyright, mask work right, or other intellectual property right relating to any combination, machine, or process in which TI components or services are used. Information published by TI regarding third-party products or services does not constitute a license to use such products or services or a warranty or endorsement thereof. Use of such information may require a license from a third party under the patents or other intellectual property of the third party, or a license from TI under the patents or other intellectual property of TI.

Reproduction of significant portions of TI information in TI data books or data sheets is permissible only if reproduction is without alteration and is accompanied by all associated warranties, conditions, limitations, and notices. TI is not responsible or liable for such altered documentation. Information of third parties may be subject to additional restrictions.

Resale of TI components or services with statements different from or beyond the parameters stated by TI for that component or service voids all express and any implied warranties for the associated TI component or service and is an unfair and deceptive business practice. TI is not responsible or liable for any such statements.

Buyer acknowledges and agrees that it is solely responsible for compliance with all legal, regulatory and safety-related requirements concerning its products, and any use of TI components in its applications, notwithstanding any applications-related information or support that may be provided by TI. Buyer represents and agrees that it has all the necessary expertise to create and implement safeguards which anticipate dangerous consequences of failures, monitor failures and their consequences, lessen the likelihood of failures that might cause harm and take appropriate remedial actions. Buyer will fully indemnify TI and its representatives against any damages arising out of the use of any TI components in safety-critical applications.

In some cases, TI components may be promoted specifically to facilitate safety-related applications. With such components, TI's goal is to help enable customers to design and create their own end-product solutions that meet applicable functional safety standards and requirements. Nonetheless, such components are subject to these terms.

No TI components are authorized for use in FDA Class III (or similar life-critical medical equipment) unless authorized officers of the parties have executed a special agreement specifically governing such use.

Only those TI components which TI has specifically designated as military grade or "enhanced plastic" are designed and intended for use in military/aerospace applications or environments. Buyer acknowledges and agrees that any military or aerospace use of TI components which have **not** been so designated is solely at the Buyer's risk, and that Buyer is solely responsible for compliance with all legal and regulatory requirements in connection with such use.

TI has specifically designated certain components as meeting ISO/TS16949 requirements, mainly for automotive use. In any case of use of non-designated products, TI will not be responsible for any failure to meet ISO/TS16949.

### Products

Audio	<a href="http://www.ti.com/audio">www.ti.com/audio</a>
Amplifiers	<a href="http://amplifier.ti.com">amplifier.ti.com</a>
Data Converters	<a href="http://dataconverter.ti.com">dataconverter.ti.com</a>
DLP® Products	<a href="http://www.dlp.com">www.dlp.com</a>
DSP	<a href="http://dsp.ti.com">dsp.ti.com</a>
Clocks and Timers	<a href="http://www.ti.com/clocks">www.ti.com/clocks</a>
Interface	<a href="http://interface.ti.com">interface.ti.com</a>
Logic	<a href="http://logic.ti.com">logic.ti.com</a>
Power Mgmt	<a href="http://power.ti.com">power.ti.com</a>
Microcontrollers	<a href="http://microcontroller.ti.com">microcontroller.ti.com</a>
RFID	<a href="http://www.ti-rfid.com">www.ti-rfid.com</a>
OMAP Applications Processors	<a href="http://www.ti.com/omap">www.ti.com/omap</a>
Wireless Connectivity	<a href="http://www.ti.com/wirelessconnectivity">www.ti.com/wirelessconnectivity</a>

### Applications

Automotive and Transportation	<a href="http://www.ti.com/automotive">www.ti.com/automotive</a>
Communications and Telecom	<a href="http://www.ti.com/communications">www.ti.com/communications</a>
Computers and Peripherals	<a href="http://www.ti.com/computers">www.ti.com/computers</a>
Consumer Electronics	<a href="http://www.ti.com/consumer-apps">www.ti.com/consumer-apps</a>
Energy and Lighting	<a href="http://www.ti.com/energy">www.ti.com/energy</a>
Industrial	<a href="http://www.ti.com/industrial">www.ti.com/industrial</a>
Medical	<a href="http://www.ti.com/medical">www.ti.com/medical</a>
Security	<a href="http://www.ti.com/security">www.ti.com/security</a>
Space, Avionics and Defense	<a href="http://www.ti.com/space-avionics-defense">www.ti.com/space-avionics-defense</a>
Video and Imaging	<a href="http://www.ti.com/video">www.ti.com/video</a>

### TI E2E Community

[e2e.ti.com](http://e2e.ti.com)

## Looking for pricing, stock, or lifecycle information?

Click below to explore more details on WIN SOURCE:

- ⊖ [View LM3211MTX-ADJ/NOPB on WIN SOURCE](#)
- ⊖ [Texas Instruments](#) Information

## Optimize Your Supply Chain with WIN SOURCE Solutions

- ✓ Global Sourcing Solution
- ✓ Obsolete Management
- ✓ Cost Control Management
- ✓ Shortage Management
- ✓ Alternative Solution
- ✓ Excess Inventory Management