



THE DATASHEET OF LM337T/NOPB



LM137, LM337-N 3-Terminal Adjustable Negative Regulators

1 Features

- 1.5-A Output Current
- Line Regulation 0.01%/V (Typical)
- Load Regulation 0.3% (Typical)
- 77-dB Ripple Rejection
- 50 ppm/°C Temperature Coefficient
- Thermal Overload Protection
- Internal Short-Circuit Current Limiting Protections

2 Applications

- Industrial Power Supplies
- Factory Automation Systems
- Building Automation Systems
- PLC Systems
- Instrumentation
- IGBT Drive Negative Gate Supplies
- Networking
- Set-Top Boxes

3 Description

The LM137 and LM337-N are adjustable 3-terminal negative voltage regulators capable of supplying –1.5 A or more currents over an output voltage range of –1.25 V to –37 V. It requires only two external resistors to set the output voltage and one output capacitor for frequency compensation. The circuit design has been optimized for excellent regulation and low thermal transients. Further, the LM137 and LM337-N feature internal current limiting, thermal shutdown and safe-area compensation, making it virtually blowout-proof against overloads.

The LM137 and LM337-N are ideal complements to the LM117 and LM317 adjustable positive regulators. The LM137 has a wider operating temperature range than the LM337-N and is also offered in military and space qualified versions.

Device Information⁽¹⁾

PART NUMBER	PACKAGE	BODY SIZE (NOM)
LM137	TO (3)	8.255 mm × 8.255 mm
LM337-N	SOT-223 (4)	3.50 mm × 6.50 mm
	TO (3)	8.255 mm × 8.255 mm
	TO-220 (3)	10.16 mm × 14.986 mm

(1) For all available packages, see the orderable addendum at the end of the data sheet. The LF01 is a lead formed (bent) version of the TO-220 package.

Adjustable Negative Voltage Regulator

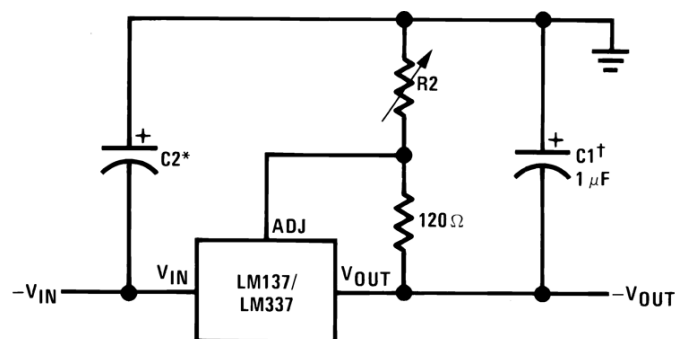

Full output current not available at high input-output voltages

$$-V_{OUT} = -1.25V \left(1 + \frac{R2}{120} \right) + (-I_{ADJ} \times R2)$$

†C1 = 1-μF solid tantalum or 10-μF aluminum electrolytic required for stability

*C2 = 1-μF solid tantalum is required only if regulator is more than 4" from power-supply filter capacitor

Output capacitors in the range of 1-μF to 1000-μF of aluminum or tantalum electrolytic are commonly used to provide improved output impedance and rejection of transients



Table of Contents

1 Features 1 2 Applications 1 3 Description 1 4 Revision History 2 5 Pin Configuration and Functions 3 6 Specifications 4 6.1 Absolute Maximum Ratings 4 6.2 ESD Ratings..... 4 6.3 Recommended Operating Conditions 4 6.4 Thermal Information 4 6.5 Electrical Characteristics..... 5 6.6 Typical Characteristics 6 7 Detailed Description 8 7.1 Overview 8 7.2 Functional Block Diagram 8 7.3 Feature Description..... 8 7.4 Device Functional Modes..... 10	8 Application and Implementation 12 8.1 Application Information..... 12 8.2 Typical Applications 12 9 Power Supply Recommendations 16 10 Layout 16 10.1 Layout Guidelines 16 10.2 Layout Example 16 10.3 Thermal Considerations 17 11 Device and Documentation Support 18 11.1 Documentation Support 18 11.2 Related Links 18 11.3 Community Resources..... 18 11.4 Trademarks 18 11.5 Electrostatic Discharge Caution..... 18 11.6 Glossary 18 12 Mechanical, Packaging, and Orderable Information 18
---	--

4 Revision History

Changes from Revision D (April 2013) to Revision E	Page
<ul style="list-style-type: none"> • Added <i>ESD Ratings</i> table, <i>Feature Description</i> section, <i>Device Functional Modes</i>, <i>Application and Implementation</i> section, <i>Power Supply Recommendations</i> section, <i>Layout</i> section, <i>Device and Documentation Support</i> section, and <i>Mechanical, Packaging, and Orderable Information</i> section. 1 • Deleted soldering information from <i>Absolute Maximum Ratings</i> 4 	
<hr/>	
Changes from Revision C (April 2013) to Revision D	Page
<ul style="list-style-type: none"> • Changed layout of National Data Sheet to TI format 7 	

5 Pin Configuration and Functions

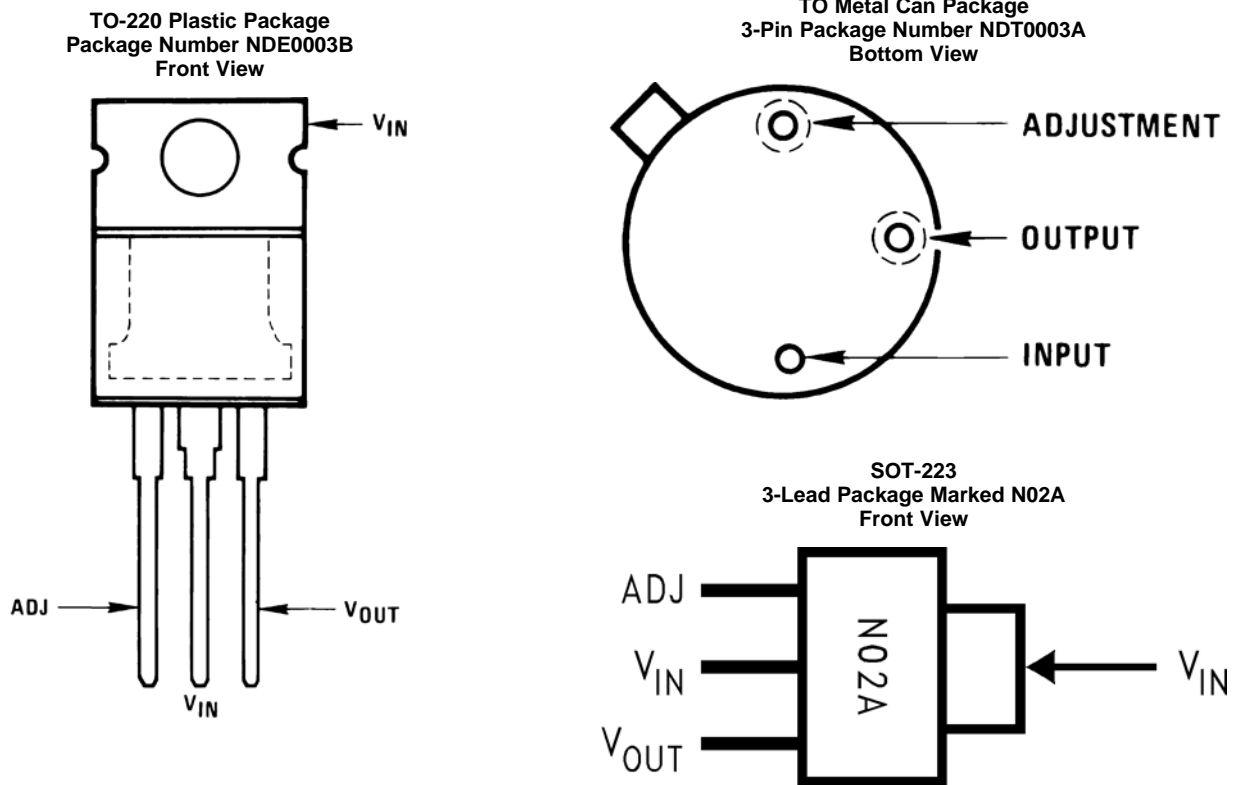

Pin Functions

NAME	PIN			I/O	DESCRIPTION
	TO-220	TO	SOT-223		
ADJ	1	1	1	—	Adjust pin
V_{IN}	2, TAB	3, CASE	2, 4	I	Input voltage pin for the regulator
V_{OUT}	3	2	3	O	Output voltage pin for the regulator

6 Specifications

6.1 Absolute Maximum Ratings

		MIN	MAX	UNIT
Power dissipation		Internally Limited		
Input-output voltage differential		-0.3	40	V
Operating junction temperature	LM137	-55	150	°C
	LM337-N	0	125	
	LM337I	-40	125	
Storage temperature, T_{stg}		-65	150	°C

6.2 ESD Ratings

			VALUE	UNIT
$V_{(ESD)}$	Electrostatic discharge	Human-body model (HBM), per ANSI/ESDA/JEDEC JS-001 ⁽¹⁾	±2000	V

- (1) JEDEC document JEP155 states that 500-V HBM allows safe manufacturing with a standard ESD control process. Pins listed as ±2000 V may actually have higher performance.

6.3 Recommended Operating Conditions

over operating free-air temperature range (unless otherwise noted)

		MIN	MAX	UNIT
Operating junction temperature	LM137	-55	150	°C
	LM337-N	0	125	
	LM337I	-40	125	

6.4 Thermal Information

THERMAL METRIC ⁽¹⁾		LM137	LM337-N		UNIT	
		NDT (TO)	NDT (TO)	DCY (SOT-223)		NDE OR NDG (TO-220)
		3 PINS	3 PINS	3 PINS		3 PINS
$R_{\theta JA}$	Junction-to-ambient thermal resistance	140 ⁽²⁾	140 ⁽²⁾	58.3	22.9	°C/W
$R_{\theta JC(top)}$	Junction-to-case (top) thermal resistance	12	12	36.6	15.7	°C/W
$R_{\theta JB}$	Junction-to-board thermal resistance	—	—	7.2	4.1	°C/W
Ψ_{JT}	Junction-to-top characterization parameter	—	—	1.3	2.4	°C/W
Ψ_{JB}	Junction-to-board characterization parameter	—	—	7	4.1	°C/W
$R_{\theta JC(bot)}$	Junction-to-case (bottom) thermal resistance	—	—	—	1	°C/W

- (1) For more information about traditional and new thermal metrics, see the *Semiconductor and IC Package Thermal Metrics* application report, [SPRA953](#).
 (2) No heat sink.

6.5 Electrical Characteristics

Unless otherwise specified, these specifications apply $-55^{\circ}\text{C} \leq T_j \leq 150^{\circ}\text{C}$ for the LM137, $0^{\circ}\text{C} \leq T_j \leq 125^{\circ}\text{C}$ for the LM337-N; $V_{\text{IN}} - V_{\text{OUT}} = 5\text{ V}$; and $I_{\text{OUT}} = 0.1\text{ A}$ for the TO package and $I_{\text{OUT}} = 0.5\text{ A}$ for the SOT-223 and TO-220 packages. Although power dissipation is internally limited, these specifications are applicable for power dissipations of 2 W for the TO and SOT-223, and 20 W for the TO-220. I_{MAX} is 1.5 A for the SOT-223 and TO-220 packages, and 0.2 A for the TO package.

PARAMETER	TEST CONDITIONS	LM137			LM337-N			UNIT	
		MIN	TYP	MAX	MIN	TYP	MAX		
Line regulation	$T_J = 25^{\circ}\text{C}$, $3\text{ V} \leq V_{\text{IN}} - V_{\text{OUT}} \leq 40\text{ V}^{(1)}$ $I_L = 10\text{ mA}$		0.01	0.02		0.01	0.04	%/V	
Load regulation	$T_J = 25^{\circ}\text{C}$, $10\text{ mA} \leq I_{\text{OUT}} \leq I_{\text{MAX}}$		0.3%	0.5%		0.3%	1%		
Thermal regulation	$T_J = 25^{\circ}\text{C}$, 10-ms Pulse		0.002	0.02		0.003	0.04	%/W	
Adjustment pin current			65	100		65	100	μA	
Adjustment pin current charge	$10\text{ mA} \leq I_L \leq I_{\text{MAX}}$ $3\text{ V} \leq V_{\text{IN}} - V_{\text{OUT}} \leq 40\text{ V}$, $T_A = 25^{\circ}\text{C}$		2	5		2	5	μA	
Reference voltage	$3\text{ V} \leq V_{\text{IN}} - V_{\text{OUT}} \leq 40\text{ V}$, ⁽²⁾ $10\text{ mA} \leq I_{\text{OUT}} \leq I_{\text{MAX}}$, $P \leq P_{\text{MAX}}$	$T_J = 25^{\circ}\text{C}$ ⁽²⁾	-1.225	-1.25	-1.275	-1.213	-1.25	-1.287	V
		$-55^{\circ}\text{C} \leq T_J \leq 150^{\circ}\text{C}$	-1.2	-1.25	-1.3	-1.2	-1.25	-1.3	V
Line regulation	$3\text{ V} \leq V_{\text{IN}} - V_{\text{OUT}} \leq 40\text{ V}$, ⁽¹⁾		0.02	0.05		0.02	0.07	%/V	
Load regulation	$10\text{ mA} \leq I_{\text{OUT}} \leq I_{\text{MAX}}$, ⁽¹⁾		0.3%	1%		0.3%	1.5%		
Temperature stability	$T_{\text{MIN}} \leq T_j \leq T_{\text{MAX}}$		0.6%			0.6%			
Minimum load current	$ V_{\text{IN}} - V_{\text{OUT}} \leq 40\text{ V}$		2.5	5		2.5	10	mA	
	$ V_{\text{IN}} - V_{\text{OUT}} \leq 10\text{ V}$		1.2	3		1.5	6	mA	
Current limit	$ V_{\text{IN}} - V_{\text{OUT}} \leq 15\text{ V}$	K, DCY and NDE package	1.5	2.2	3.5	1.5	2.2	3.7	A
		NDT package	0.5	0.8	1.8	0.5	0.8	1.9	A
	$ V_{\text{IN}} - V_{\text{OUT}} = 40\text{ V}$, $T_J = 25^{\circ}\text{C}$	K, DCY and NDE package	0.24	0.4		0.15	0.4		A
		NDT package	0.15	0.17		0.1	0.17		A
RMS output noise, % of V_{OUT}	$T_J = 25^{\circ}\text{C}$, $10\text{ Hz} \leq f \leq 10\text{ kHz}$		0.003%			0.003%			
Ripple rejection ratio	$V_{\text{OUT}} = -10\text{ V}$, $f = 120\text{ Hz}$		60			60		dB	
	$C_{\text{ADJ}} = 10\text{ }\mu\text{F}$		66	77		66	77	dB	
Long-term stability	$T_J = 125^{\circ}\text{C}$, 1000 Hours		0.3%	1%		0.3%	1%		

- (1) Regulation is measured at constant junction temperature, using pulse testing with a low duty cycle. Changes in output voltage due to heating effects are covered under the specification for thermal regulation. Load regulation is measured on the output pin at a point $\frac{1}{8}$ in. below the base of the TO packages.
- (2) Selected devices with tightened tolerance reference voltage available.

6.6 Typical Characteristics

(NDE Package)

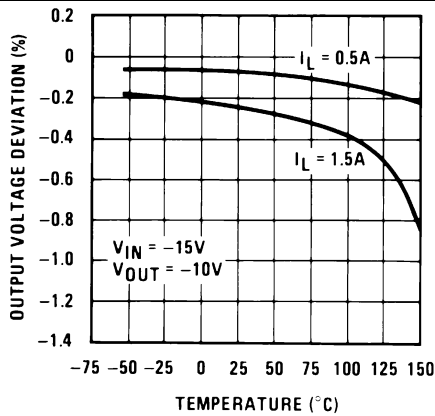

Figure 1. Load Regulation

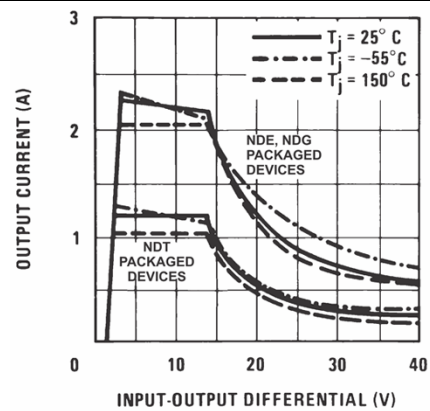

Figure 2. Current Limit

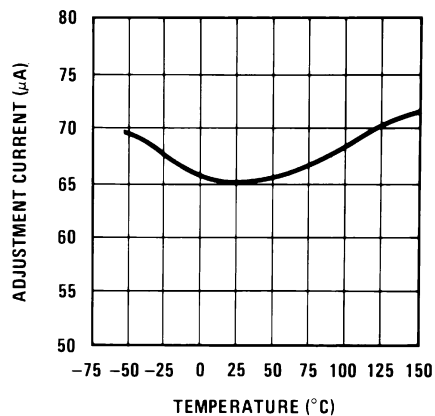

Figure 3. Adjustment Current

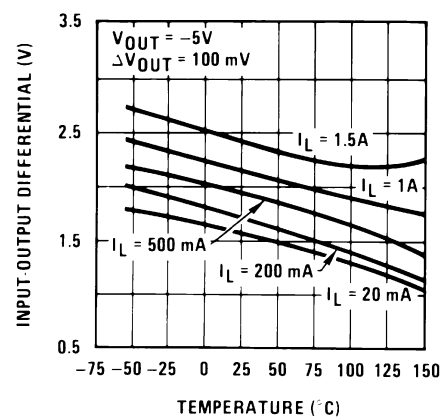

Figure 4. Dropout Voltage

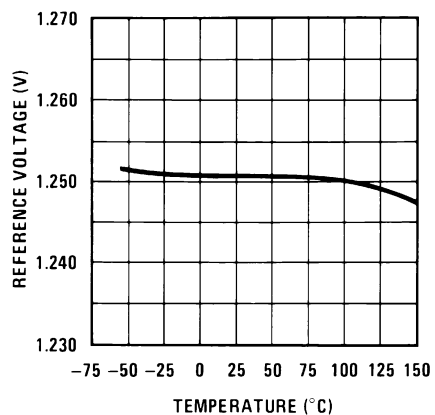

Figure 5. Temperature Stability

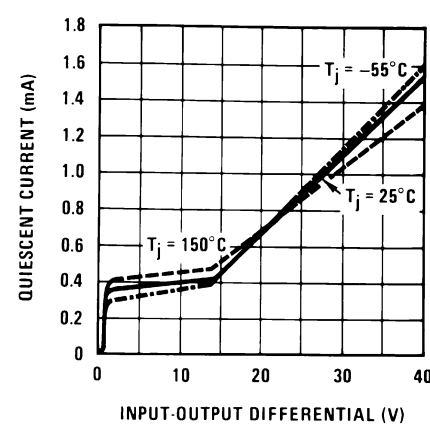

Figure 6. Minimum Operating Current

Typical Characteristics (continued)

(NDE Package)

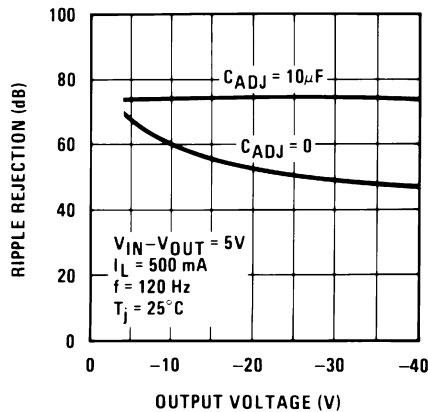

Figure 7. Ripple Rejection

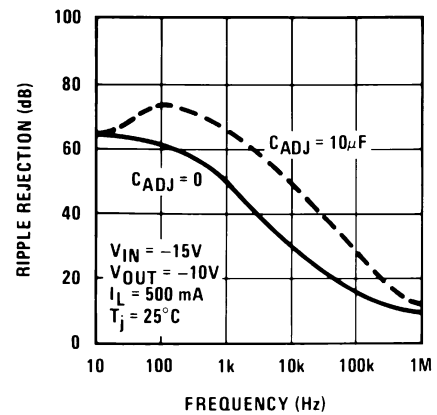

Figure 8. Ripple Rejection

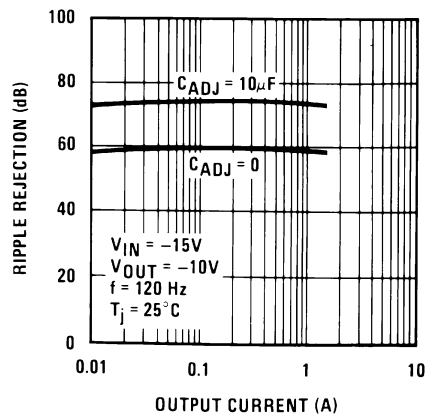

Figure 9. Ripple Rejection

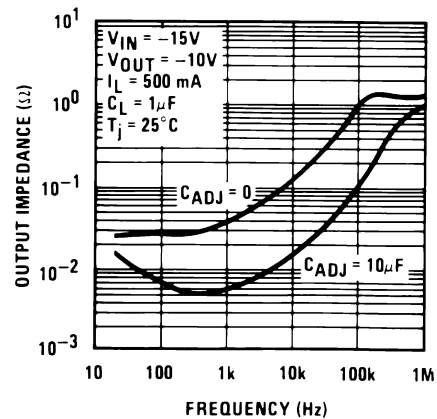

Figure 10. Output Impedance

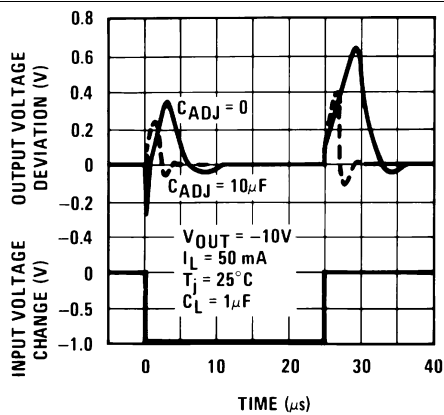

Figure 11. Line Transient Response

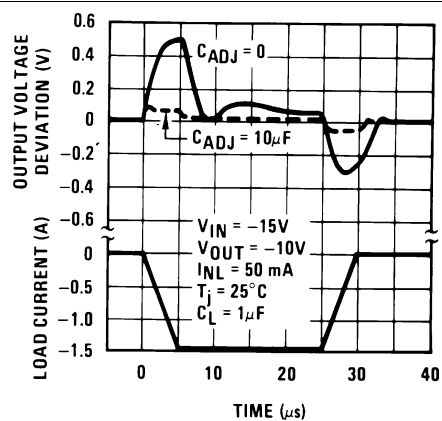

Figure 12. Load Transient Response

7 Detailed Description

7.1 Overview

In operation, the LM137 and LM337-N develops a nominal -1.25-V reference voltage between the output and adjustment terminal. The reference voltage is impressed across program resistor R1 (120 Ω for example) and, because the voltage is constant, a constant current then flows through the output set resistor R2, giving an output voltage calculated by Equation 1.

$$-V_{OUT} = -1.25V \left(1 + \frac{R2}{120} \right) + (-I_{ADJ} \times R2) \tag{1}$$

7.2 Functional Block Diagram

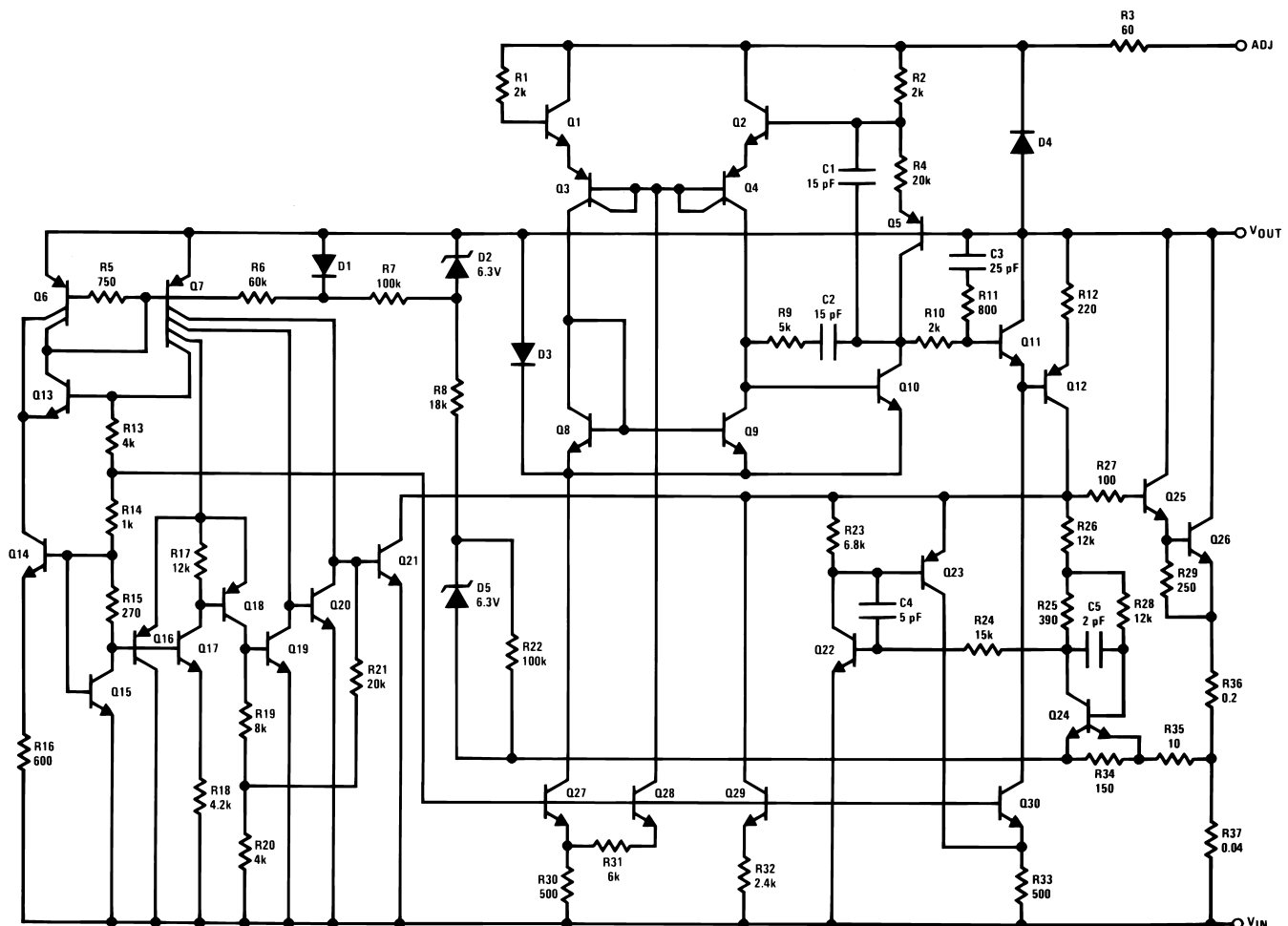

7.3 Feature Description

7.3.1 Thermal Regulation

When power is dissipated in an IC, a temperature gradient occurs across the IC chip affecting the individual IC circuit components. With an IC regulator, this gradient can be especially severe because power dissipation is large. Thermal regulation is the effect of these temperature gradients on output voltage (in percentage output change) per Watt of power change in a specified time. Thermal regulation error is independent of electrical regulation or temperature coefficient, and occurs within 5 ms to 50 ms after a change in power dissipation. Thermal regulation depends on IC layout as well as electrical design. The thermal regulation of a voltage regulator is defined as the percentage change of V_{OUT} , per Watt, within the first 10 ms after a step of power is applied. The LM137 device's specification is 0.02%/W, maximum.

Feature Description (continued)

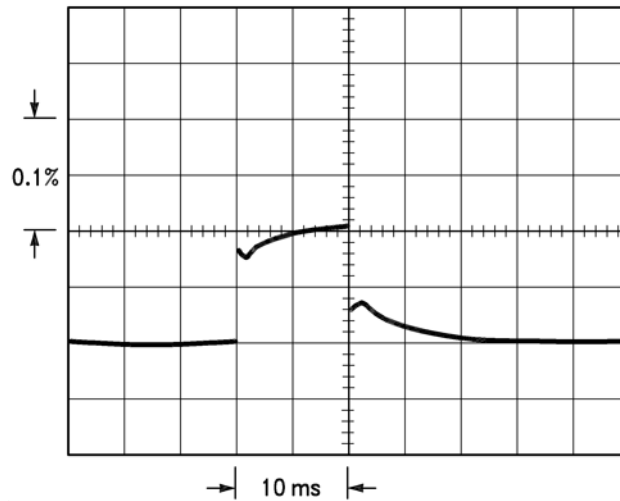

LM137
 $V_{OUT} = -10\text{ V}$
 $V_{IN} - V_{OUT} = -40\text{ V}$
 $I_{IL} = 0\text{ A} \rightarrow 0.25\text{ A} \rightarrow 0\text{ A}$
 Vertical sensitivity, 5 mV/div

Figure 13. Output Drift (10W Pulse for 10ms)

In [Figure 13](#), a typical LM137 device's output drifts only 3 mV (or 0.03% of $V_{OUT} = -10\text{ V}$) when a 10-W pulse is applied for 10 ms. This performance is thus well inside the specification limit of $0.02\%/W \times 10\text{ W} = 0.2\%$ maximum. When the 10-W pulse is ended, the thermal regulation again shows a 3-mV step at the LM137 chip cools off.

NOTE

The load regulation error of about 8 mV (0.08%) is additional to the thermal regulation error.

In [Figure 14](#), when the 10-W pulse is applied for 100 ms, the output drifts only slightly beyond the drift in the first 10 ms, and the thermal error stays well within 0.1% (10 mV).

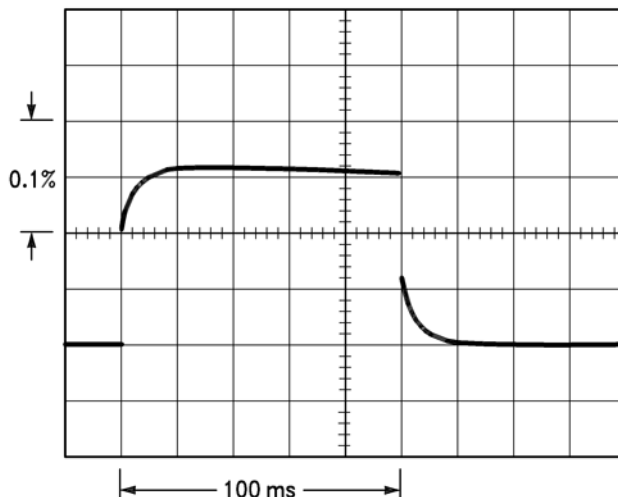
Feature Description (continued)

LM137
 $V_{OUT} = -10\text{ V}$
 $V_{IN} - V_{OUT} = -40\text{ V}$
 $I_L = 0\text{ A} \rightarrow 0.25\text{ A} \rightarrow 0\text{ A}$
 Horizontal sensitivity, 20 ms/div

Figure 14. Output Drift (10-W Pulse for 100 ms)

7.4 Device Functional Modes

7.4.1 Protection Diodes

When external capacitors are used with any IC regulator, it is sometimes necessary to add protection diodes to prevent the capacitors from discharging through low current points into the regulator. Most 10- μF capacitors have low enough internal series resistance to deliver 20-A spikes when shorted. Although the surge is short, there is enough energy to damage parts of the IC.

When an output capacitor is connected to a negative output regulator and the input is shorted, the output capacitor pulls current out of the output of the regulator. The current depends on the value of the capacitor, the output voltage of the regulator, and the rate at which V_{IN} is shorted to ground.

The bypass capacitor on the adjustment terminal can discharge through a low current junction. Discharge occurs when either the input, or the output, is shorted. [Figure 15](#) shows the placement of the protection diodes.

Device Functional Modes (continued)

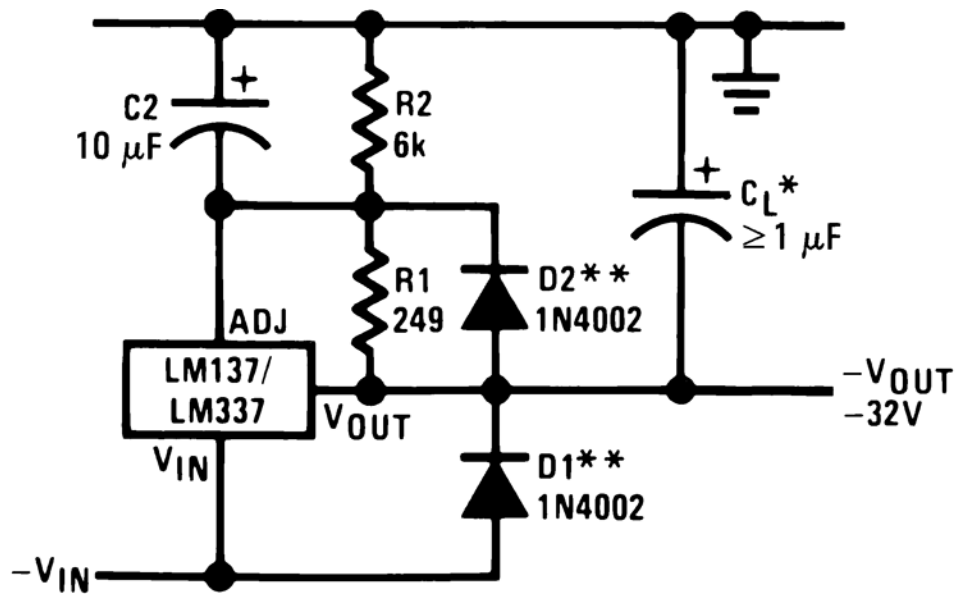

*When C_L is larger than 20 μF , D1 protects the LM137 in case the input supply is shorted

**When C_2 is larger than 10 μF and $-V_{OUT}$ is larger than -25V, D2 protects the LM137 in case the output is shorted

Figure 15. Regulator With Protection Diodes

8 Application and Implementation

NOTE

Information in the following applications sections is not part of the TI component specification, and TI does not warrant its accuracy or completeness. TI's customers are responsible for determining suitability of components for their purposes. Customers should validate and test their design implementation to confirm system functionality.

8.1 Application Information

The LM137 and LM337-N are versatile, high performance, negative output linear regulators with high accuracy and a wide temperature range. An output capacitor can be added to further improve transient response, and the ADJ pin can be bypassed to achieve very high ripple-rejection ratios. The device's functionality can be utilized in many different applications that require negative voltage supplies, such as bipolar amplifiers, operational amplifiers, and constant current regulators.

8.2 Typical Applications

8.2.1 Adjustable Negative Voltage Regulator

The LM137 and LM337-N can be used as a simple, negative output regulator to enable a variety of output voltages needed for demanding applications. By using an adjustable R2 resistor, a variety of negative output voltages can be made possible as shown in [Figure 16](#).

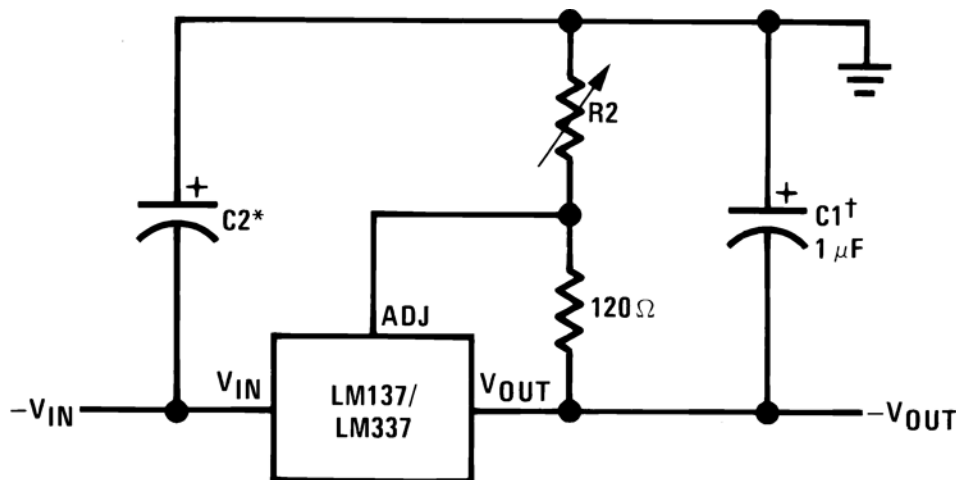

Full output current not available at high input-output voltages

†C1 = 1- μ F solid tantalum or 10- μ F aluminum electrolytic required for stability

*C2 = 1- μ F solid tantalum is required only if regulator is more than 4 inches from power-supply filter capacitor

Output capacitors in the range of 1 μ F to 1000 μ F of aluminum or tantalum electrolytic are commonly used to provide improved output impedance and rejection of transients

Figure 16. Adjustable Negative Voltage Regulator

$$-V_{OUT} = -1.25V \left(1 + \frac{R2}{120} \right) + (-I_{ADJ} \times R2) \quad (2)$$

8.2.1.1 Design Requirements

The device component count is very minimal, employing two resistors as part of a voltage divider circuit and an output capacitor for load regulation. An input capacitor is needed if the device is more than 4 inches from the filter capacitors.

8.2.1.2 Detailed Design Procedure

The output voltage is set based on the selection of the two resistors, R1 and R2, as shown in [Figure 16](#).

Typical Applications (continued)

8.2.1.3 Application Curve

As shown in Figure 17, the maximum output current capability is limited by the input-output voltage differential, package type, and junction temperature.

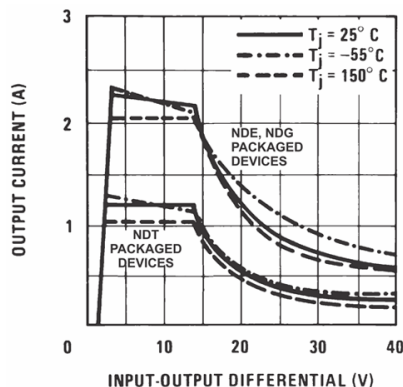
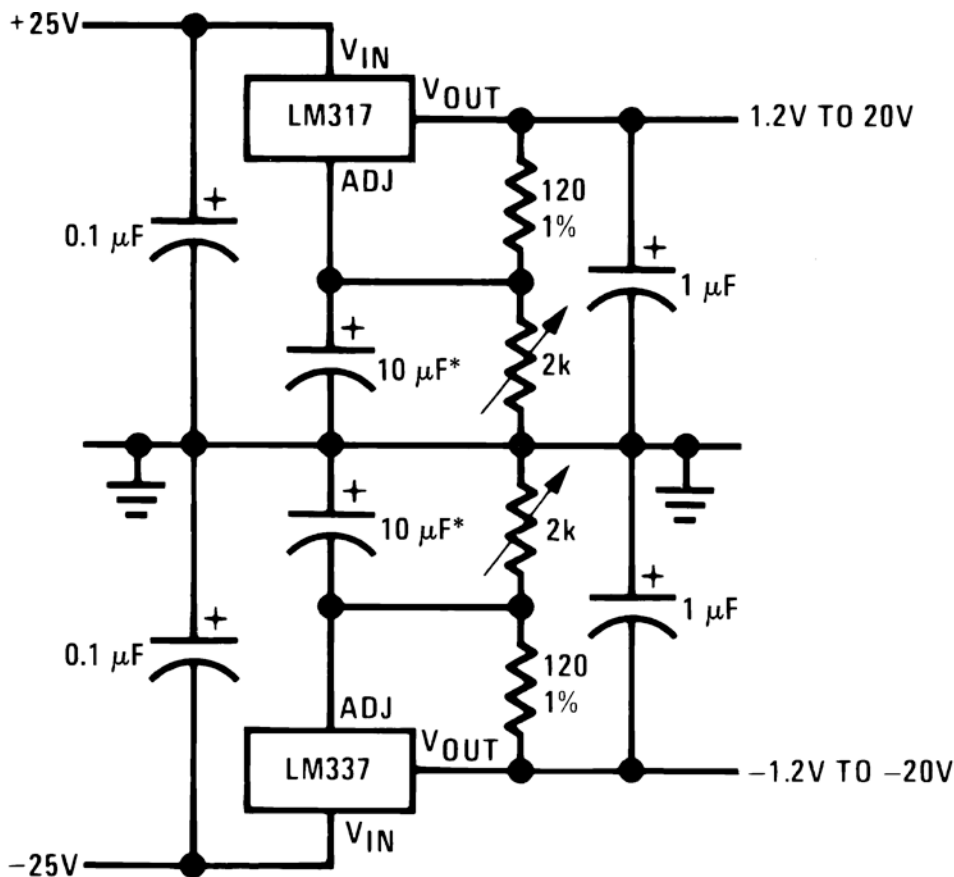

Figure 17. Current Limit

8.2.2 Adjustable Lab Voltage Regulator

The LM337-N can be combined with a positive regulator such as the LM317-N to provide both a positive and negative voltage rail. This can be useful in applications that use bi-directional amplifiers and dual-supply operational amplifiers.



Full output current not available at high input-output voltages

*The 10 μF capacitors are optional to improve ripple rejection

Typical Applications (continued)
8.2.3 Current Regulator

A simple, fixed current regulator can be made by placing a resistor between the V_{OUT} and ADJ pins of the LM137. By regulating a constant 1.25 V between these two terminals, a constant current can be delivered.

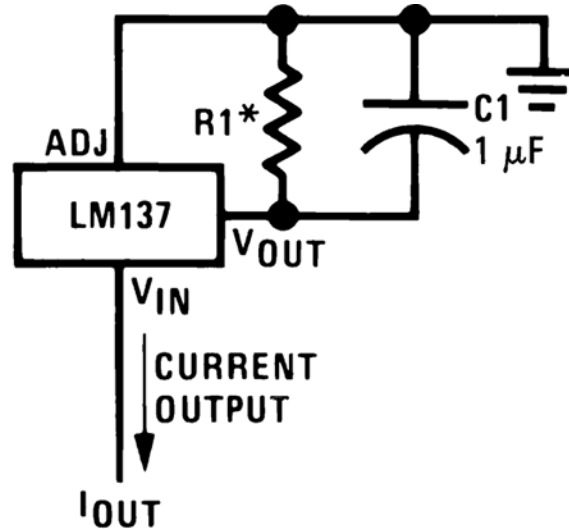

$$I_{OUT} = \frac{1.250V}{R1}$$

$$*0.8 \Omega \leq R1 \leq 120 \Omega$$

(3)

(4)

8.2.4 -5.2-V Regulator with Electronic Shutdown

The LM337-N can be used with a PNP transistor to provide shutdown control from a TTL control signal. The PNP can short or open the ADJ pin to GND. When ADJ is shorted to GND by the PNP, the output is -1.3V. When ADJ is disconnected from GND by the PNP, then the LM337-N outputs the programmed output of -5.2 V.

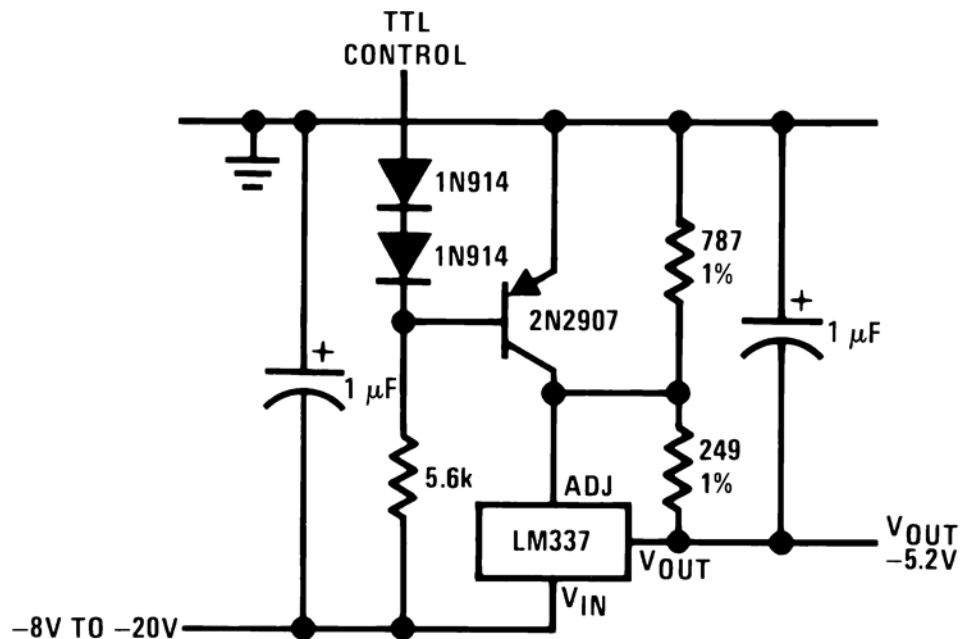

Minimum output \approx -1.3 V when control input is low

Typical Applications (continued)

8.2.5 High Stability -10-V Regulator

Using a high stability shunt voltage reference in the feedback path, such as the LM329, provides damping necessary for a stable, low noise output.

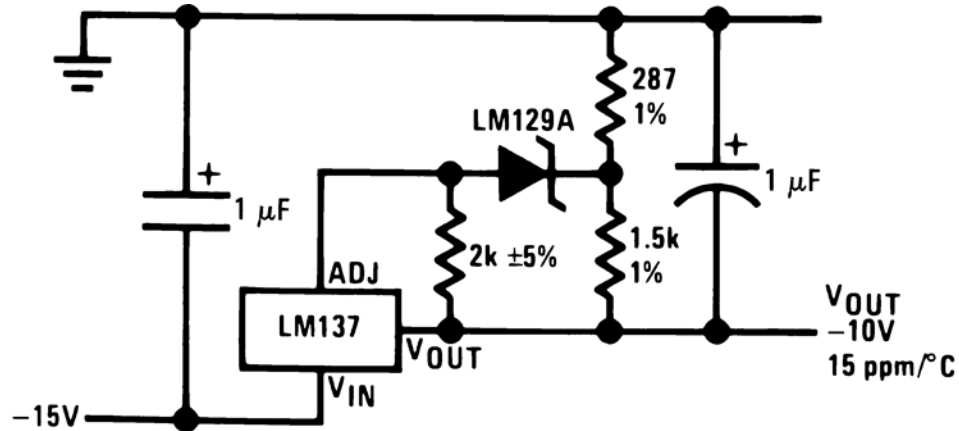

9 Power Supply Recommendations

The input supply to the LM137 and LM337-N must be kept at a voltage level such that its maximum input to output differential voltage rating is not exceeded. The minimum dropout voltage must also be met with extra headroom when possible to keep the LM137 and LM337-N in regulation. TI recommends an input capacitor, especially when the input pin is placed more than 4 inches away from the power-supply filter capacitor.

10 Layout

10.1 Layout Guidelines

Some layout guidelines must be followed to ensure proper regulation of the output voltage with minimum noise. Traces carrying the load current must be wide to reduce the amount of parasitic trace inductance and the feedback loop from V_{OUT} to ADJ must be kept as short as possible. To improve PSRR, a bypass capacitor can be placed at the ADJ pin and must be placed as close as possible to the IC. In cases when V_{IN} shorts to ground, an external diode must be placed from V_{IN} to V_{OUT} to divert the surge current into the output capacitor and protect the IC. Similarly, in cases when a large bypass capacitor is placed at the ADJ pin and V_{OUT} shorts to ground, an external diode must be placed from V_{OUT} to ADJ to provide a path for the bypass capacitor to discharge. These diodes must be placed close to the corresponding IC pins to increase their effectiveness.

10.2 Layout Example

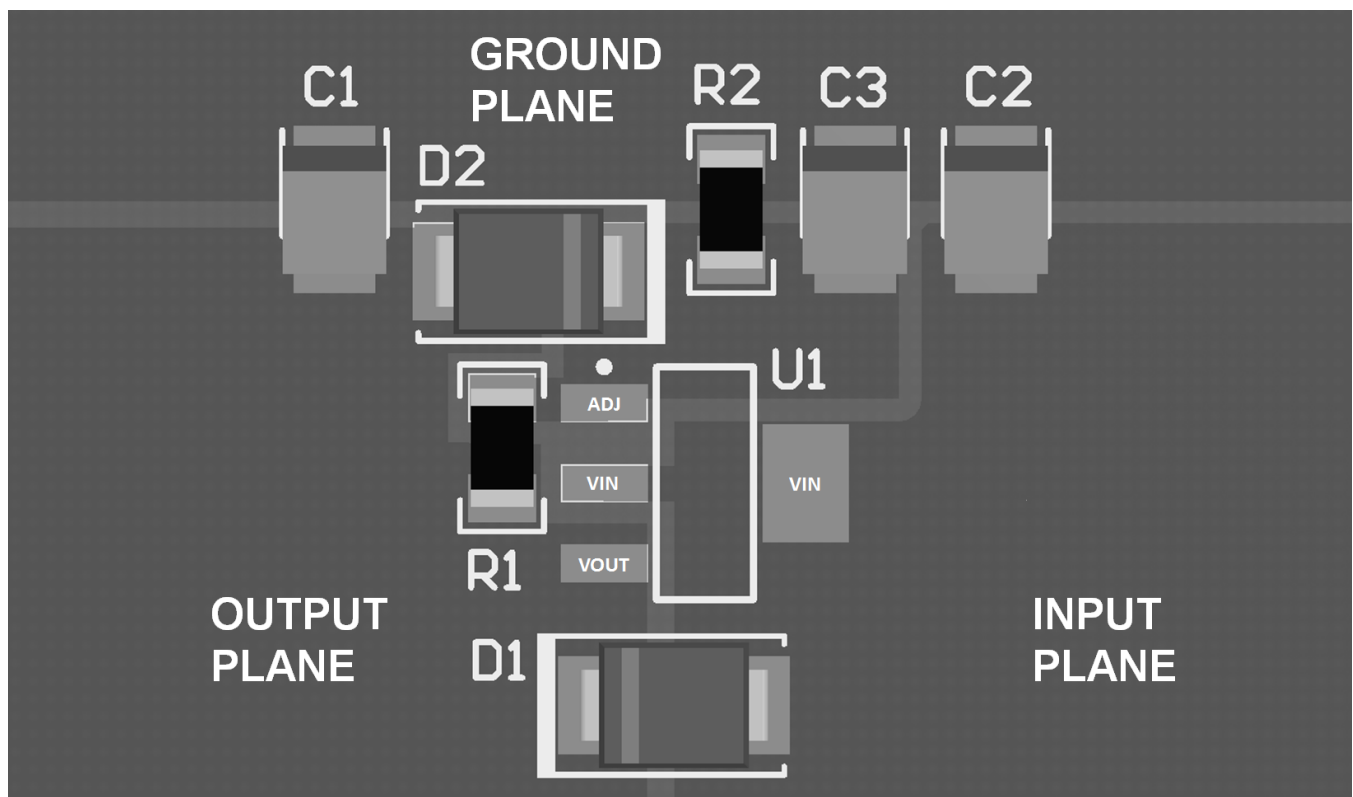

Figure 18. Layout Example (SOT-223)

10.3 Thermal Considerations

10.3.1 Heatsinking SOT-223 Package Parts

The SOT-223 DCY packages use a copper plane on the PCB and the PCB itself as a heatsink. To optimize the heat sinking ability of the plane and PCB, solder the tab of the package to the plane.

Figure 19 and Figure 20 show the information for the SOT-223 package. Figure 20 assumes a $\theta_{(J-A)}$ of 75°C/W for 1 ounce copper and 51°C/W for 2 ounce copper and a maximum junction temperature of 125°C.

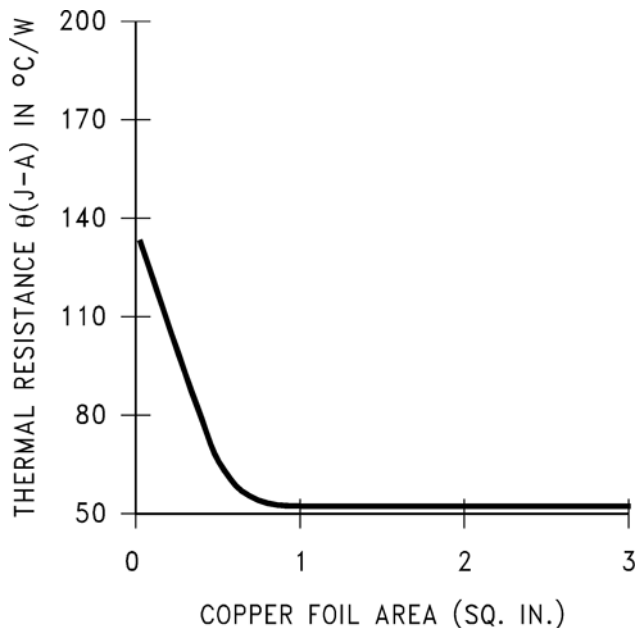

Figure 19. $\theta_{(J-A)}$ vs Copper (2 ounce) Area for the SOT-223 Package

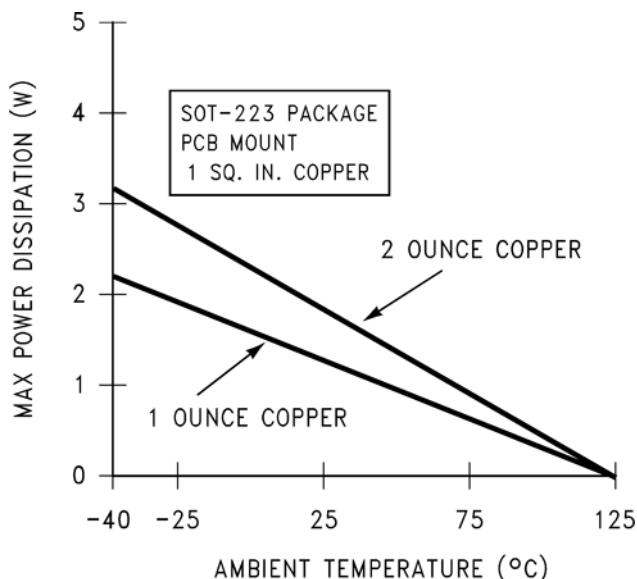

Figure 20. Maximum Power Dissipation vs T_{AMB} for the SOT-223 Package

See AN-1028, [SNVA036](#), for power enhancement techniques to be used with the SOT-223 package.

11 Device and Documentation Support

11.1 Documentation Support

11.1.1 Related Documentation

For related documentation see the following:

AN-1028, [SNVA036](#)

11.2 Related Links

The table below lists quick access links. Categories include technical documents, support and community resources, tools and software, and quick access to sample or buy.

Table 1. Related Links

PARTS	PRODUCT FOLDER	SAMPLE & BUY	TECHNICAL DOCUMENTS	TOOLS & SOFTWARE	SUPPORT & COMMUNITY
LM137	Click here	Click here	Click here	Click here	Click here
LM337-N	Click here	Click here	Click here	Click here	Click here

11.3 Community Resources

The following links connect to TI community resources. Linked contents are provided "AS IS" by the respective contributors. They do not constitute TI specifications and do not necessarily reflect TI's views; see TI's [Terms of Use](#).

TI E2E™ Online Community *TI's Engineer-to-Engineer (E2E) Community*. Created to foster collaboration among engineers. At e2e.ti.com, you can ask questions, share knowledge, explore ideas and help solve problems with fellow engineers.

Design Support *TI's Design Support* Quickly find helpful E2E forums along with design support tools and contact information for technical support.

11.4 Trademarks

E2E is a trademark of Texas Instruments.
All other trademarks are the property of their respective owners.

11.5 Electrostatic Discharge Caution



These devices have limited built-in ESD protection. The leads should be shorted together or the device placed in conductive foam during storage or handling to prevent electrostatic damage to the MOS gates.

11.6 Glossary

[SLYZ022](#) — *TI Glossary*.

This glossary lists and explains terms, acronyms, and definitions.

12 Mechanical, Packaging, and Orderable Information

The following pages include mechanical, packaging, and orderable information. This information is the most current data available for the designated devices. This data is subject to change without notice and revision of this document. For browser-based versions of this data sheet, refer to the left-hand navigation.

PACKAGING INFORMATION

Orderable Device	Status (1)	Package Type	Package Drawing	Pins	Package Qty	Eco Plan (2)	Lead/Ball Finish (6)	MSL Peak Temp (3)	Op Temp (°C)	Device Marking (4/5)	Samples
LM137H	ACTIVE	TO	NDT	3	500	Green (RoHS & no Sb/Br)	AU Call TI	Level-1-NA-UNLIM	-55 to 150	(LM137HP+, LM137H P+)	Samples
LM137H/NOPB	ACTIVE	TO	NDT	3	500	Green (RoHS & no Sb/Br)	AU Call TI	Level-1-NA-UNLIM	-55 to 150	(LM137HP+, LM137H P+)	Samples
LM337IMP	NRND	SOT-223	DCY	4	1000	TBD	Call TI	Call TI	-40 to 125	N02A	
LM337IMP/NOPB	ACTIVE	SOT-223	DCY	4	1000	Green (RoHS & no Sb/Br)	CU SN	Level-1-260C-UNLIM	-40 to 125	N02A	Samples
LM337IMPX	NRND	SOT-223	DCY	4	2000	TBD	Call TI	Call TI	-40 to 125	N02A	
LM337IMPX/NOPB	ACTIVE	SOT-223	DCY	4	2000	Green (RoHS & no Sb/Br)	CU SN	Level-1-260C-UNLIM	-40 to 125	N02A	Samples
LM337T	NRND	TO-220	NDE	3	45	TBD	Call TI	Call TI	0 to 125	LM337T P+	
LM337T/LF01	ACTIVE	TO-220	NDG	3	45	Pb-Free (RoHS Exempt)	CU SN	Level-3-245C-168 HR	0 to 125	LM337T P+	Samples
LM337T/NOPB	ACTIVE	TO-220	NDE	3	45	Pb-Free (RoHS Exempt)	CU SN	Level-1-NA-UNLIM	0 to 125	LM337T P+	Samples

(1) The marketing status values are defined as follows:

ACTIVE: Product device recommended for new designs.

LIFEBUY: TI has announced that the device will be discontinued, and a lifetime-buy period is in effect.

NRND: Not recommended for new designs. Device is in production to support existing customers, but TI does not recommend using this part in a new design.

PREVIEW: Device has been announced but is not in production. Samples may or may not be available.

OBSELETE: TI has discontinued the production of the device.

(2) **RoHS:** TI defines "RoHS" to mean semiconductor products that are compliant with the current EU RoHS requirements for all 10 RoHS substances, including the requirement that RoHS substance do not exceed 0.1% by weight in homogeneous materials. Where designed to be soldered at high temperatures, "RoHS" products are suitable for use in specified lead-free processes. TI may reference these types of products as "Pb-Free".

RoHS Exempt: TI defines "RoHS Exempt" to mean products that contain lead but are compliant with EU RoHS pursuant to a specific EU RoHS exemption.

Green: TI defines "Green" to mean the content of Chlorine (Cl) and Bromine (Br) based flame retardants meet JS709B low halogen requirements of <=1000ppm threshold. Antimony trioxide based flame retardants must also meet the <=1000ppm threshold requirement.

(3) MSL, Peak Temp. - The Moisture Sensitivity Level rating according to the JEDEC industry standard classifications, and peak solder temperature.

(4) There may be additional marking, which relates to the logo, the lot trace code information, or the environmental category on the device.

⁽⁵⁾ Multiple Device Markings will be inside parentheses. Only one Device Marking contained in parentheses and separated by a "-" will appear on a device. If a line is indented then it is a continuation of the previous line and the two combined represent the entire Device Marking for that device.

⁽⁶⁾ Lead/Ball Finish - Orderable Devices may have multiple material finish options. Finish options are separated by a vertical ruled line. Lead/Ball Finish values may wrap to two lines if the finish value exceeds the maximum column width.

Important Information and Disclaimer:The information provided on this page represents TI's knowledge and belief as of the date that it is provided. TI bases its knowledge and belief on information provided by third parties, and makes no representation or warranty as to the accuracy of such information. Efforts are underway to better integrate information from third parties. TI has taken and continues to take reasonable steps to provide representative and accurate information but may not have conducted destructive testing or chemical analysis on incoming materials and chemicals. TI and TI suppliers consider certain information to be proprietary, and thus CAS numbers and other limited information may not be available for release.

In no event shall TI's liability arising out of such information exceed the total purchase price of the TI part(s) at issue in this document sold by TI to Customer on an annual basis.

TAPE AND REEL INFORMATION

QUADRANT ASSIGNMENTS FOR PIN 1 ORIENTATION IN TAPE

*All dimensions are nominal

Device	Package Type	Package Drawing	Pins	SPQ	Reel Diameter (mm)	Reel Width W1 (mm)	A0 (mm)	B0 (mm)	K0 (mm)	P1 (mm)	W (mm)	Pin1 Quadrant
LM337IMP	SOT-223	DCY	4	1000	330.0	16.4	7.0	7.5	2.2	12.0	16.0	Q3
LM337IMP/NOPB	SOT-223	DCY	4	1000	330.0	16.4	7.0	7.5	2.2	12.0	16.0	Q3
LM337IMPX	SOT-223	DCY	4	2000	330.0	16.4	7.0	7.5	2.2	12.0	16.0	Q3
LM337IMPX/NOPB	SOT-223	DCY	4	2000	330.0	16.4	7.0	7.5	2.2	12.0	16.0	Q3

TAPE AND REEL BOX DIMENSIONS

*All dimensions are nominal

Device	Package Type	Package Drawing	Pins	SPQ	Length (mm)	Width (mm)	Height (mm)
LM337IMP	SOT-223	DCY	4	1000	367.0	367.0	35.0
LM337IMP/NOPB	SOT-223	DCY	4	1000	367.0	367.0	35.0
LM337IMPX	SOT-223	DCY	4	2000	367.0	367.0	35.0
LM337IMPX/NOPB	SOT-223	DCY	4	2000	367.0	367.0	35.0

NDE0003B

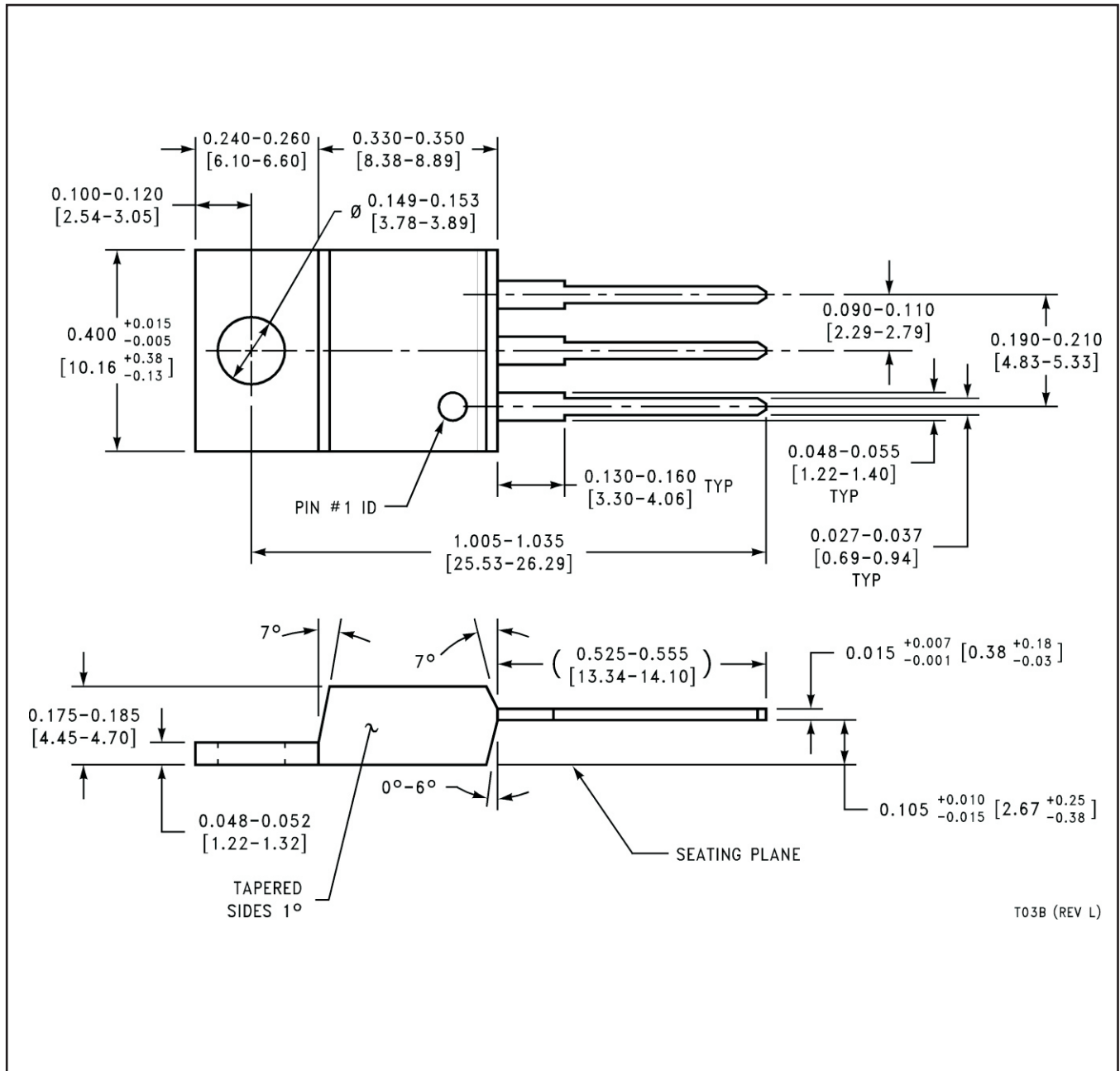

DCY (R-PDSO-G4)

PLASTIC SMALL-OUTLINE

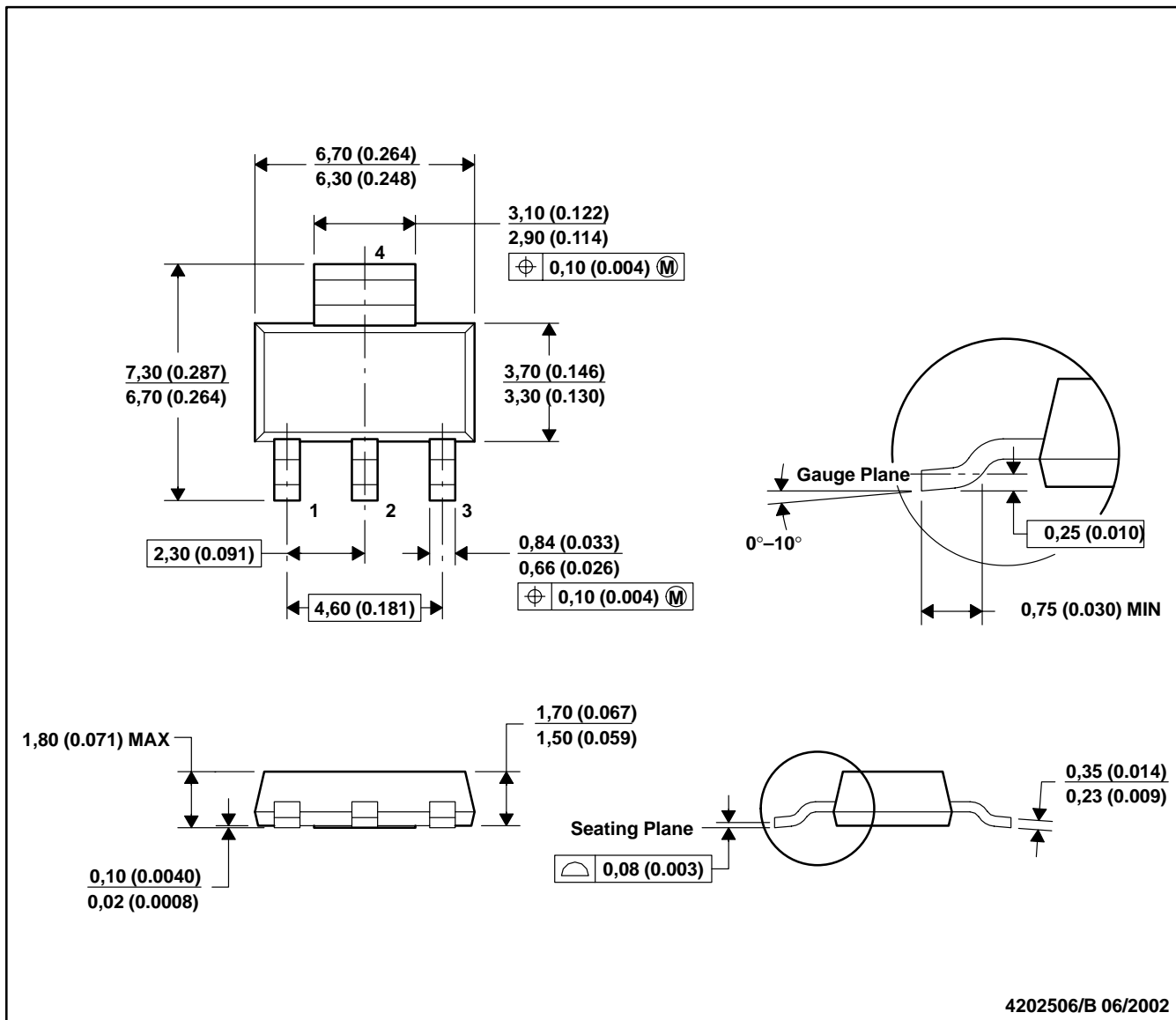

- NOTES: A. All linear dimensions are in millimeters (inches).
 B. This drawing is subject to change without notice.
 C. Body dimensions do not include mold flash or protrusion.
 D. Falls within JEDEC TO-261 Variation AA.

DCY (R-PDSO-G4)

PLASTIC SMALL OUTLINE

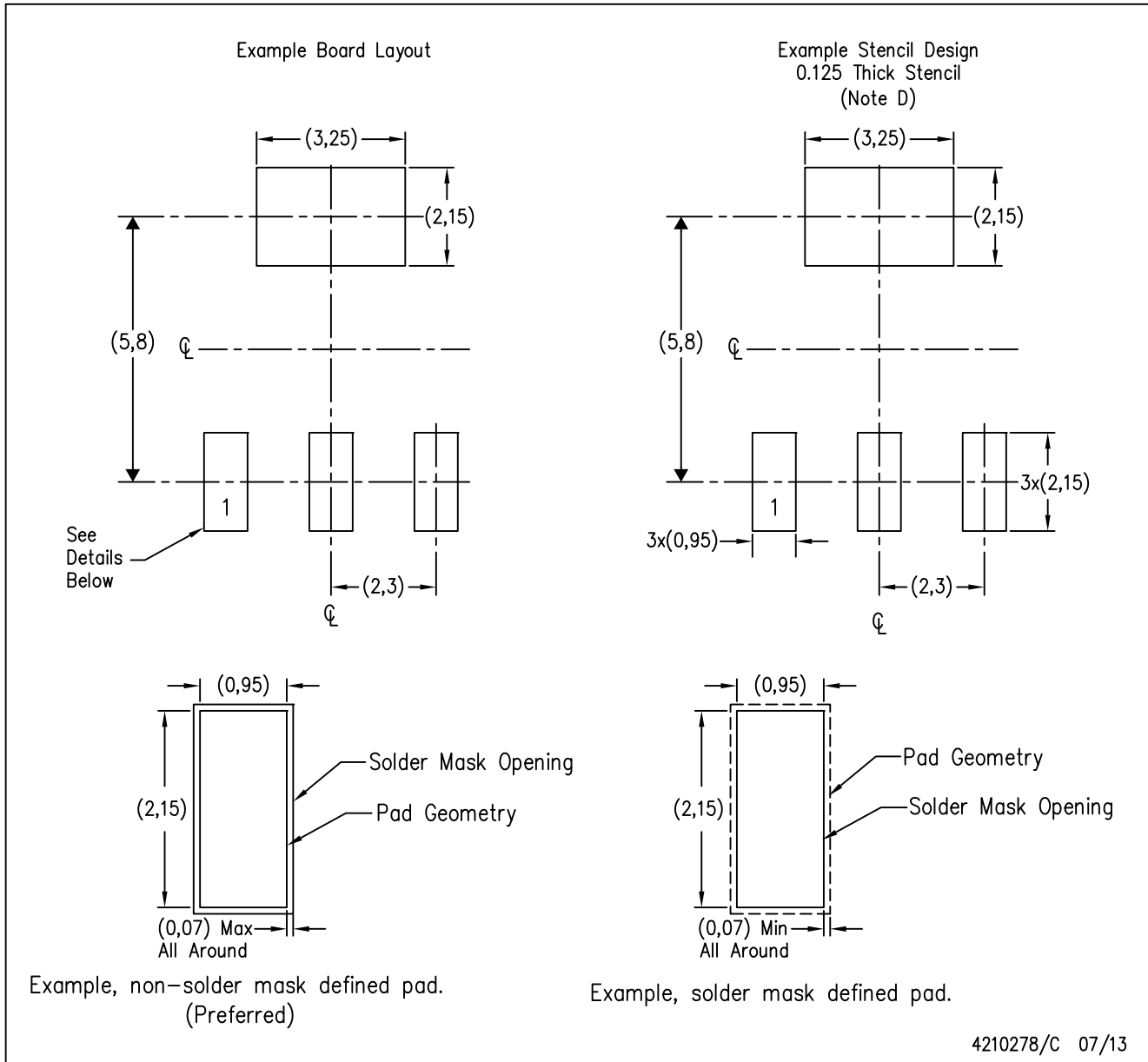

- NOTES:
- A. All linear dimensions are in millimeters.
 - B. This drawing is subject to change without notice.
 - C. Publication IPC-7351 is recommended for alternate designs.
 - D. Laser cutting apertures with trapezoidal walls and also rounding corners will offer better paste release. Customers should contact their board assembly site for stencil recommendations. Refer to IPC 7525 for stencil design considerations.

NDG0003F

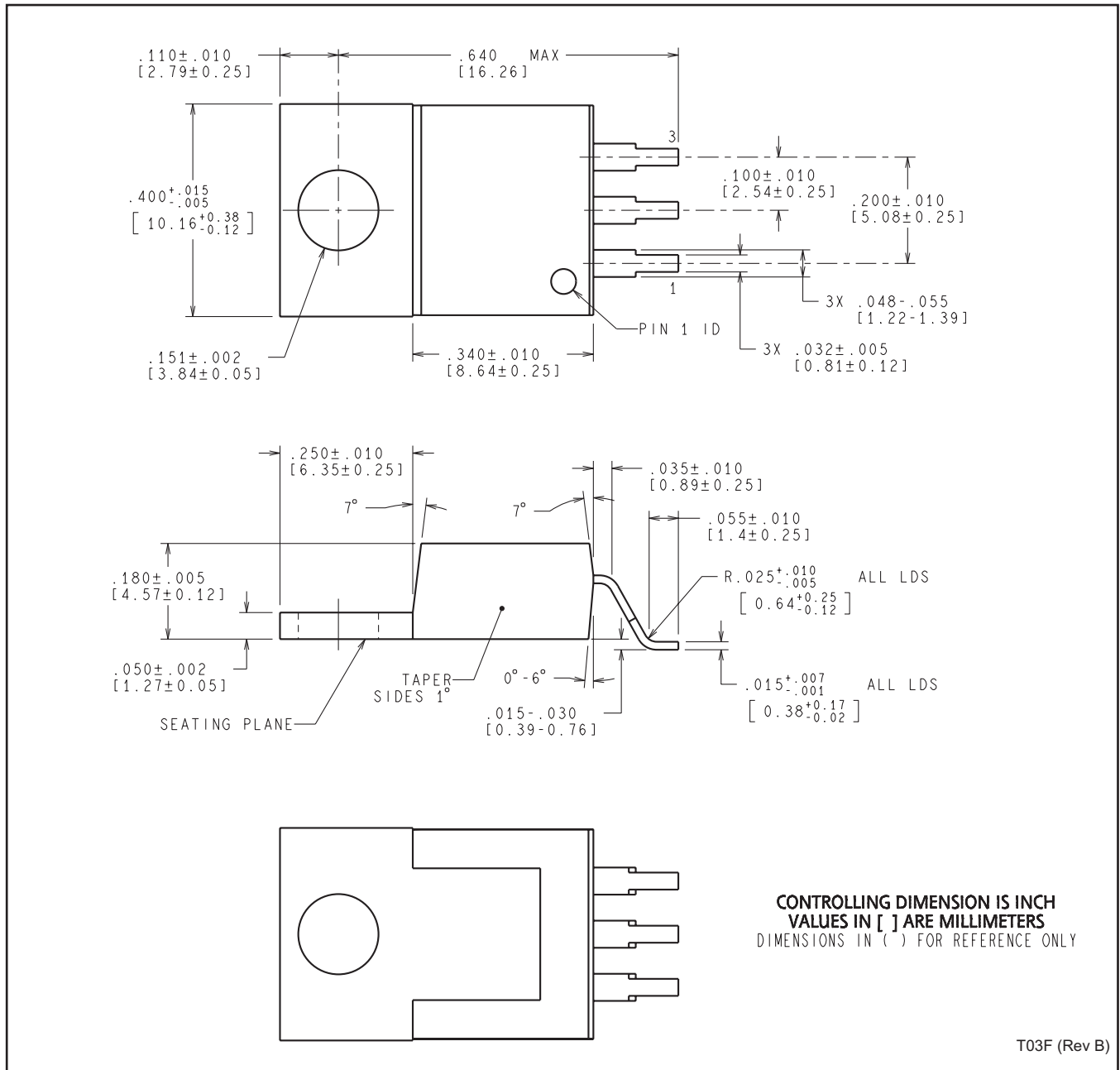

T03F (Rev B)

NDT0003A

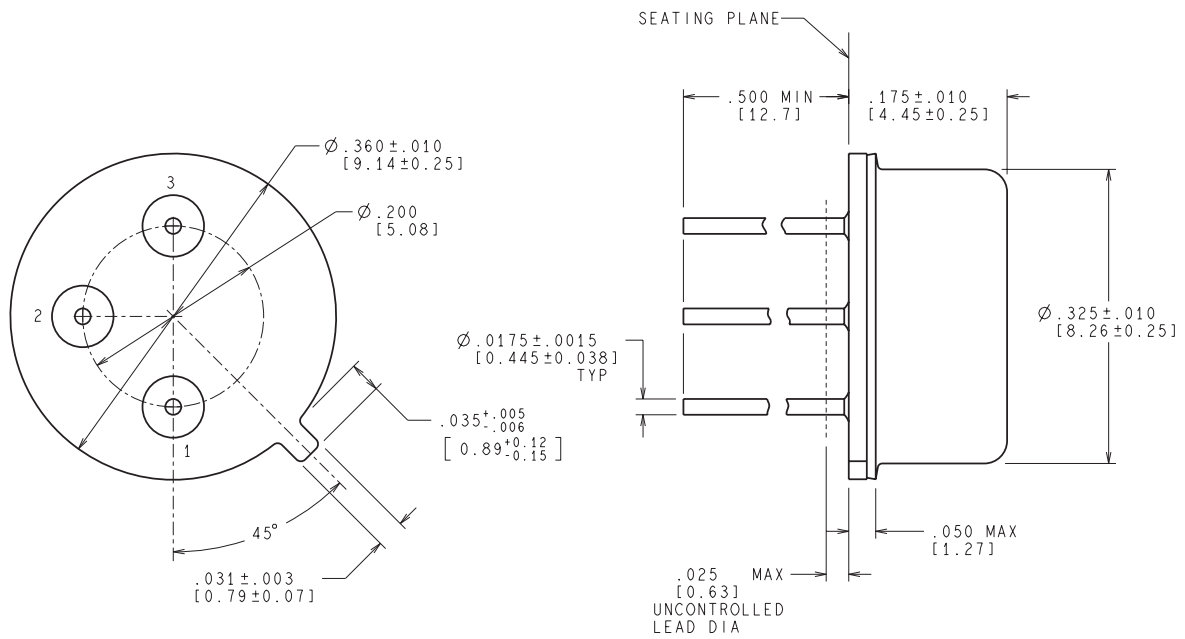

CONTROLLING DIMENSION IS INCH
VALUES IN [] ARE MILLIMETERS

MIL-PRF-38535
CONFIGURATION CONTROL

H03A (Rev D)

IMPORTANT NOTICE AND DISCLAIMER

TI PROVIDES TECHNICAL AND RELIABILITY DATA (INCLUDING DATASHEETS), DESIGN RESOURCES (INCLUDING REFERENCE DESIGNS), APPLICATION OR OTHER DESIGN ADVICE, WEB TOOLS, SAFETY INFORMATION, AND OTHER RESOURCES "AS IS" AND WITH ALL FAULTS, AND DISCLAIMS ALL WARRANTIES, EXPRESS AND IMPLIED, INCLUDING WITHOUT LIMITATION ANY IMPLIED WARRANTIES OF MERCHANTABILITY, FITNESS FOR A PARTICULAR PURPOSE OR NON-INFRINGEMENT OF THIRD PARTY INTELLECTUAL PROPERTY RIGHTS.

These resources are intended for skilled developers designing with TI products. You are solely responsible for (1) selecting the appropriate TI products for your application, (2) designing, validating and testing your application, and (3) ensuring your application meets applicable standards, and any other safety, security, or other requirements. These resources are subject to change without notice. TI grants you permission to use these resources only for development of an application that uses the TI products described in the resource. Other reproduction and display of these resources is prohibited. No license is granted to any other TI intellectual property right or to any third party intellectual property right. TI disclaims responsibility for, and you will fully indemnify TI and its representatives against, any claims, damages, costs, losses, and liabilities arising out of your use of these resources.

TI's products are provided subject to TI's Terms of Sale (www.ti.com/legal/termsofsale.html) or other applicable terms available either on ti.com or provided in conjunction with such TI products. TI's provision of these resources does not expand or otherwise alter TI's applicable warranties or warranty disclaimers for TI products.

Mailing Address: Texas Instruments, Post Office Box 655303, Dallas, Texas 75265
Copyright © 2019, Texas Instruments Incorporated

Looking for pricing, stock, or lifecycle information?

Click below to explore more details on WIN SOURCE:

 [View LM337T/NOPB on WIN SOURCE](#)

 [Texas Instruments](#) Information

Optimize Your Supply Chain with WIN SOURCE Solutions

-  Global Sourcing Solution
-  Obsolete Management
-  Cost Control Management
-  Shortage Management
-  Alternative Solution
-  Excess Inventory Management