



**THE DATASHEET OF
LM3722IM5-2.32/NOPB**



LM3722/LM3723/LM3724 5-Pin Microprocessor Reset Circuits

 Check for Samples: [LM3722](#), [LM3723](#), [LM3724](#)

FEATURES

- Precise Monitoring of 2.5V, 3.3V, and 5V Supply Voltages
- Fully Specified Over Temperature
 - Industrial: -40°C to $+85^{\circ}\text{C}$
 - Extended: -40°C to $+125^{\circ}\text{C}$
- 100 ms Minimum Power-On Reset pulse Width, 190 ms Typical:
 - Active-Low $\overline{\text{RESET}}$ Output (LM3722)
 - Active-High RESET Output (LM3723)
 - Active-Low $\overline{\text{RESET}}$ Open Drain Output (LM3724)
- Guaranteed $\overline{\text{RESET}}$ Output Valid for $V_{\text{CC}} \geq 1\text{V}$
- Low Supply Current, $6\mu\text{A}$ Typical
- Power Supply Transient Immunity
- Compatible with MAX811/812 Applications

APPLICATIONS

- Microprocessor Systems
- Computers
- Controllers
- Intelligent Instruments
- Portable/Battery-Powered Equipment

Typical Application Circuits

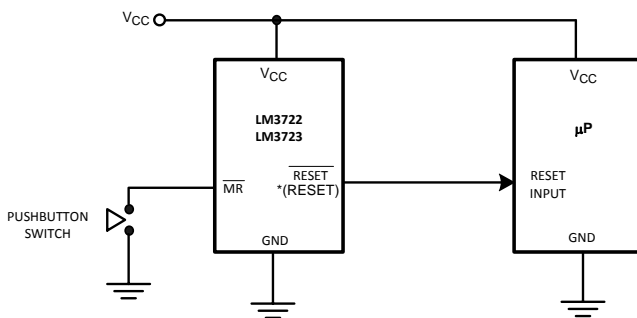
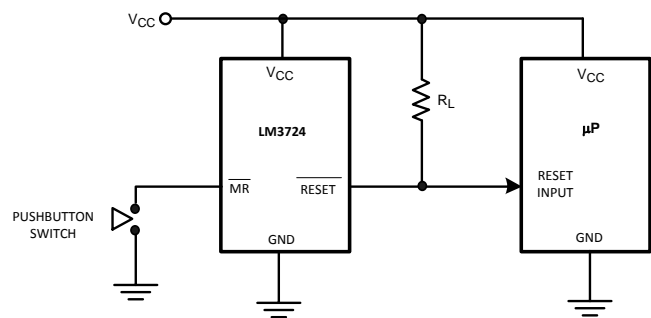

Figure 1. Typical Application Circuit

 Figure 2. Typical Application Circuit with R_L Connection

DESCRIPTION

The LM3722/LM3723/LM3724 microprocessor supervisory circuits monitor the power supplies in microprocessor and digital systems. They provide a reset to the microprocessor during power-up, power-down, brown-out conditions, and manual reset.

The LM3722/LM3723/LM3724 asserts a reset signal whenever the supply decreases below the factory-programmed reset threshold. Reset will be asserted for at least 100ms even after V_{CC} rises above the reset threshold.

The LM3722 has an active-low $\overline{\text{RESET}}$ push-pull output. The LM3723 has an active-high RESET push-pull output. The LM3724 has an active-low open-drain $\overline{\text{RESET}}$ output.

Three standard reset voltage options are available, suitable for monitoring 5V, 3.3V, and 2.5V supply voltages. Additional reset voltages are also available; contact Texas Instruments for details.

With a low supply current of only $6\mu\text{A}$, the LM3722/LM3723/LM3724 are ideal for use in portable equipment. The LM3722/LM3723/LM3724 are available in the 5-pin SOT-23 package.



Please be aware that an important notice concerning availability, standard warranty, and use in critical applications of Texas Instruments semiconductor products and disclaimers thereto appears at the end of this data sheet.

All trademarks are the property of their respective owners.

Connection Diagram



*() are for LM3723

Figure 3. SOT-23-5

PIN DESCRIPTIONS

PIN	NAME	FUNCTION
1	GND	Ground reference
2	GND	Ground reference, device substrate, connect to ground.
3	$\overline{\text{RESET}}$ LM3722/LM3724	Active-low output. $\overline{\text{RESET}}$ remains low while V_{CC} is below the reset threshold voltage, and for 190 ms after V_{CC} rises above the reset threshold voltage.
	RESET LM3723	Active-high output. RESET remains high while V_{CC} is below the reset threshold, and for 190 ms after V_{CC} rises above the reset threshold.
4	$\overline{\text{MR}}$	Active-low input. Reset is asserted whenever this pin is pulled low and remains asserted for 190 ms after the $\overline{\text{MR}}$ pin goes high. May be left open.
5	V_{CC}	Supply Voltage (+5V, +3.3V, or +2.5V, nominal)

Block Diagram



Figure 4. LM3722/LM3723/LM3724 Block Diagram



These devices have limited built-in ESD protection. The leads should be shorted together or the device placed in conductive foam during storage or handling to prevent electrostatic damage to the MOS gates.

Absolute Maximum Ratings ⁽¹⁾⁽²⁾

V_{CC}, \overline{MR}	-0.3V to 6.0V
RESET, \overline{RESET}	-0.3V to ($V_{CC} + 0.3V$)
Input Current, V_{CC} Pin	20mA
Output Current, RESET, \overline{RESET} Pin	20mA
ESD Rating ⁽³⁾	2kV
Continuous Power Dissipation ($T_A = +70^\circ\text{C}$)	
SOT-23 ⁽⁴⁾	320mW
Operating Temperature Range	
Industrial:	-40°C to +85°C
Extended:	-40°C to +125°C
Maximum Junction Temperature	125°C
Storage Temperature Range	-65°C to +160°C
Lead Temperature (soldering, 10sec)	+300°C

- (1) Absolute Maximum Ratings are limits beyond which damage to the device may occur. Operating Ratings are conditions under which the device operates correctly. Operating ratings do not imply guaranteed performance limits. For guaranteed performance limits and associated test conditions, see the Electrical Characteristics.
- (2) If Military/Aerospace specified devices are required, please contact the Texas Instruments Sales Office/Distributors for availability and specifications.
- (3) The human body model is a 100pF capacitor discharged through a 1.5k Ω resistor into each pin.
- (4) At elevated temperatures, devices must be derated based on package thermal resistance. The device in the SOT-23-5 package must be derated at 4.5mW/°C at ambient temperatures above 70°C. The device has internal thermal protection.

Electrical Characteristics

Typical values are at $T_A = +25^\circ\text{C}$. Limits with standard typeface are for $T_A = +25^\circ\text{C}$, and limits in boldface type apply for the operating temperature range (-40°C to +85°C) for LM372_IM5X, and (-40°C to +125°C) for LM372_EM5X, unless otherwise noted. ⁽¹⁾

Symbol	Parameter	Conditions	Min	Typ	Max	Units
V_{CC}	V_{CC} Range		1.0		5.5	V
I_{CC}	Supply Current ($I_{LOAD} = 0A$)	LM372 _ -4.63 $V_{CC} = 5.5V$		8	15	μA
		LM372 _ -3.08 $V_{CC} = 3.6V$		7	10	
		LM372 _ -2.32 $V_{CC} = 2.5V$		6	10	
V_{TH}	Reset Threshold	LM372 _ -4.63	4.54 4.50	4.63	4.72 4.75	V
		LM372 _ -3.08	3.03 3.00	3.08	3.14 3.15	
		LM372 _ -2.32	2.27 2.25	2.32	2.37 2.40	
V_{TH} Tempco	Reset Threshold Temperature Coefficient			30		ppm/°C
t_{RD}	V_{CC} to Reset Delay ⁽²⁾	$V_{CC} = V_{TH}$ to ($V_{TH} - 100mV$)		20		μs
t_{RP}	Reset Active Timeout Period		100	190	560	ms
t_{MR}	\overline{MR} Minimum Pulse Width		10			μs
t_{MD}	\overline{MR} to Reset Propagation Delay			2		μs
	\overline{MR} Glitch Immunity ⁽³⁾			100		ns

- (1) Production testing done at $T_A = +25^\circ\text{C}$. Limits over the operating temperature range are guaranteed through correlation using Statistical Quality Control (SQC) methods.
- (2) \overline{RESET} Output for LM3722 and LM3724, RESET output for LM3723.
- (3) Glitches of 100 ns or less typically will not generate a reset pulse.

Electrical Characteristics (continued)

Typical values are at $T_A = +25^\circ\text{C}$. Limits with standard typeface are for $T_A = +25^\circ\text{C}$, and limits in boldface type apply for the operating temperature range (-40°C to $+85^\circ\text{C}$) for LM372_IM5X, and (-40°C to $+125^\circ\text{C}$) for LM372_EM5X, unless otherwise noted. ⁽¹⁾

Symbol	Parameter	Conditions	Min	Typ	Max	Units
V_{IH}	$\overline{\text{MR}}$ Input Threshold	$V_{CC} > V_{TH(\text{MAX})}$, LM372_ -4.63	2.3			V
V_{IL}					0.8	
V_{IH}		$V_{CC} > V_{TH(\text{MAX})}$, LM372_ -3.08, LM372_ -2.32	0.7 V_{CC}			
V_{IL}					0.25 V_{CC}	
	$\overline{\text{MR}}$ Pull-Up Resistance			22		k Ω
V_{OL}	$\overline{\text{RESET}}$ Output Voltage Low (LM3722)	$V_{CC} = V_{TH \text{ min}}$, $I_{\text{SINK}} = 1.2\text{mA}$, (LM3722-2.32/3.08)			0.3	V
		$V_{CC} = V_{TH \text{ min}}$, $I_{\text{SINK}} = 3.2\text{mA}$, (LM3722-4.63)			0.4	
		$V_{CC} > 1\text{V}$, $I_{\text{SINK}} = 50\mu\text{A}$			0.3	
V_{OH}	$\overline{\text{RESET}}$ Output Voltage High (LM3722)	$V_{CC} > V_{TH \text{ max}}$, $I_{\text{SOURCE}} = 500\mu\text{A}$, (LM3722-2.32/3.08)	0.8V_{CC}			V
		$V_{CC} > V_{TH \text{ max}}$, $I_{\text{SOURCE}} = 800\mu\text{A}$, (LM3722-4.63)	$V_{CC}-1.5$			
V_{OL}	RESET Output Voltage Low (LM3723)	$V_{CC} = V_{TH \text{ max}}$, $I_{\text{SINK}} = 1.2\text{mA}$ (LM3723 -2.32/3.08)			0.3	V
		$V_{CC} = V_{TH \text{ max}}$, $I_{\text{SINK}} = 3.2\text{mA}$ (LM3723 -4.63)			0.4	
V_{OH}	RESET Output Voltage High (LM3723)	$1.8\text{V} < V_{CC} < V_{TH \text{ min}}$, $I_{\text{SOURCE}} = 150\mu\text{A}$	0.8V_{CC}			V
V_{OL}	$\overline{\text{RESET}}$ Output Voltage Low (LM3724)	$V_{CC} = V_{TH \text{ min}}$, $I_{\text{SINK}} = 1.2 \text{ mA}$ (LM3724 -2.32/3.08)			0.3	V
		$V_{CC} = V_{TH \text{ min}}$, $I_{\text{SINK}} = 3.2 \text{ mA}$ (LM3724 -4.63)			0.4	
		$V_{CC} > 1\text{V}$, $I_{\text{SINK}} = 50\mu\text{A}$			0.3	
I_{IN}	$\overline{\text{RESET}}$ Output Leakage Current (LM3724)	$V_{CC} > V_{TH}$, $\overline{\text{RESET}} = 5.5\text{V}$			0.5	μA

Typical Performance Characteristics



Figure 5.



Figure 6.

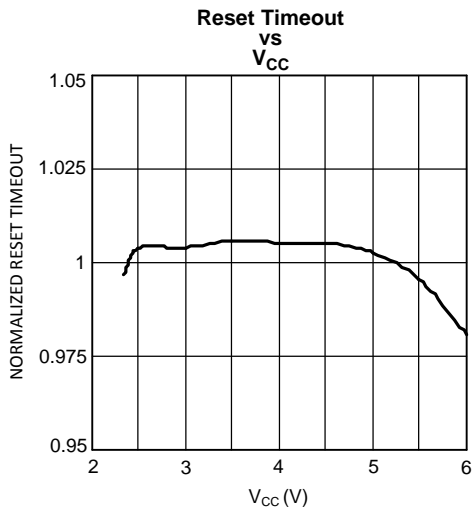

Figure 7.

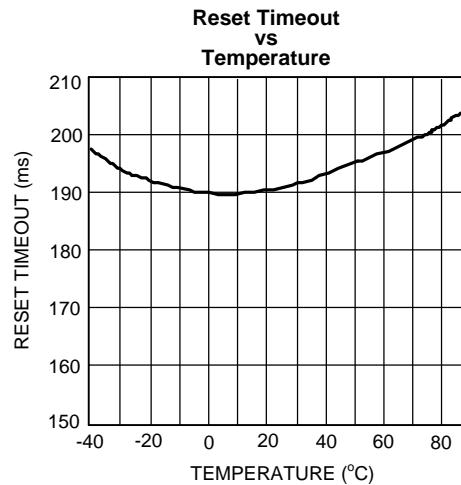

Figure 8.

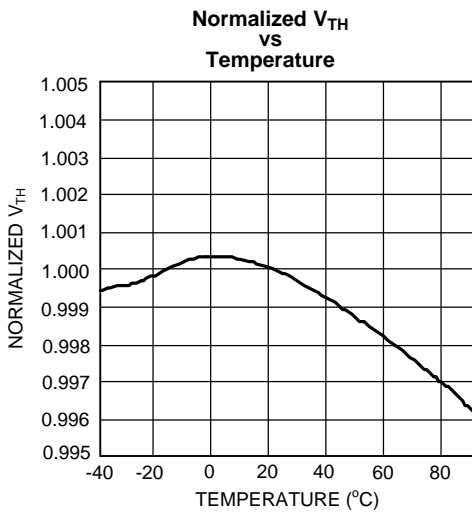

Figure 9.

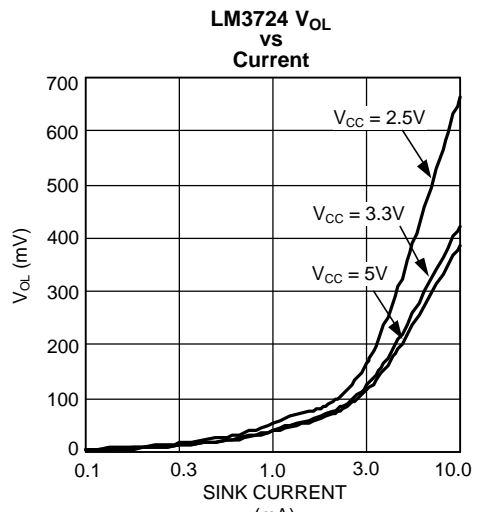

Figure 10.

Typical Performance Characteristics (continued)

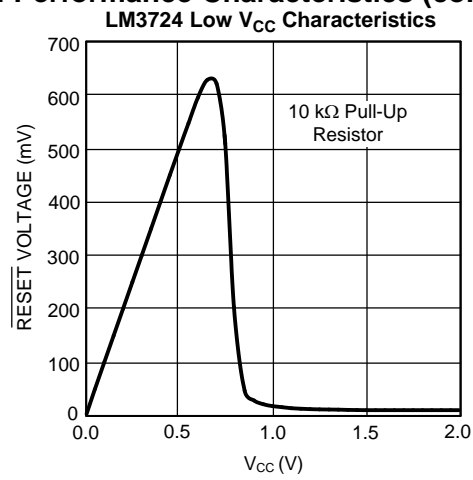

Figure 11.

Timing Diagram

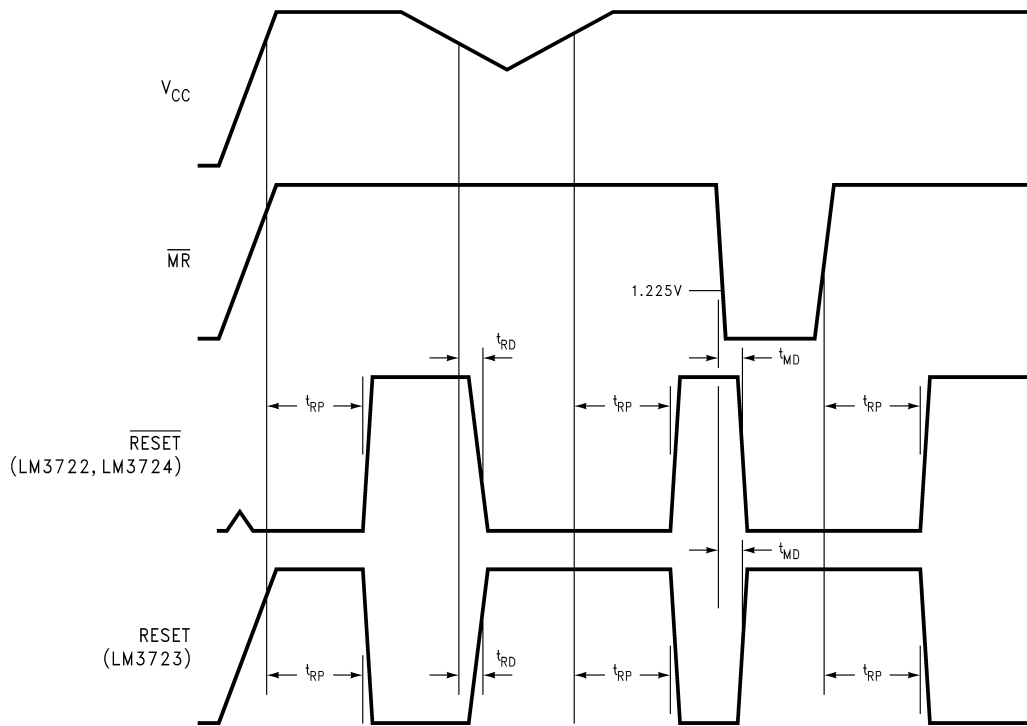

Figure 12. Timing Diagram

Circuit Information

RESET OUTPUT

The reset input of a μP initializes the device into a known state. The LM3722/LM3723/LM3724 microprocessor voltage monitoring circuits assert a forced reset output to prevent code execution errors during power-up, power-down, and brownout conditions.

\overline{RESET} is guaranteed valid for $V_{CC} \geq 1V$. Once V_{CC} exceeds the reset threshold, an internal timer maintains the output for the reset timeout period. After this interval, reset goes high and the microprocessor initializes itself into a known state. The LM3722 and LM3724 offer an active-low \overline{RESET} ; the LM3723 offers an active-high RESET.

As V_{CC} drops below the reset threshold (such as during a brownout), the reset activates (see the [NEGATIVE-GOING \$V_{CC}\$ TRANSIENTS](#) section). When V_{CC} again rises above the reset threshold, the internal timer starts. Reset holds until V_{CC} exceeds the reset threshold for longer than the reset timeout period. After this time, reset releases.

Additionally, the Manual Reset input (\overline{MR}) will initiate a forced reset. See the [MANUAL RESET INPUT \(\$\overline{MR}\$ \)](#) section.

The LM3722/LM3723/LM3724 reset outputs ignore short duration glitches on V_{CC} and \overline{MR} . See the [Applications Information](#) section for details.

RESET THRESHOLD

The LM3722/LM3723/LM3724 are available with reset voltages of 4.63V, 3.08V, and 2.32V which are suitable for monitoring 5.0V, 3.3V, and 2.5V supplies respectively. Other reset thresholds in the 2.20V to 5.0V range, in 10 mV steps, are available; contact Texas Instruments for details.

MANUAL RESET INPUT ($\overline{\text{MR}}$)

Many μP -based products require a manual reset capability, allowing the operator to initiate a reset. The $\overline{\text{MR}}$ input is fully debounced and provides an internal 22 k Ω pull-up. When the MR input is pulled below V_{IL} (0.25 V_{CC}) for more than 100 ns, $\overline{\text{reset}}$ is asserted after a typical delay of 2 μs . Reset remains active as long as MR is held low, and releases after $\overline{\text{MR}}$ rises above V_{IH} and the reset timeout period expires. Use $\overline{\text{MR}}$ with digital logic to assert reset or to daisy chain supervisory circuits.

APPLICATIONS INFORMATION

BENEFITS OF PRECISION RESET THRESHOLDS

A microprocessor supply supervisor must provide a reset output within a predictable range of the supply voltage. A common threshold range is between 5% and 10% below the nominal supply voltage. The 4.63V, 3.08V and 2.32V options of the LM3722/LM3723/LM3724 use highly accurate circuitry to ensure that the reset threshold occurs only within this range (for 5.0V, 3.3V and 2.5V supplies). Table 1 shows how the standard reset thresholds apply to 5.0V, 3.3V, and 2.5V nominal supply voltages.

Table 1. Monitored Tolerance Table

Reset Threshold	Supply Voltage		
	2.5V	3.3V	5.0V
4.63 \pm %			90.8-94.4%
3.08 \pm %		91.8-95.2%	
2.32 \pm %	90.8-94.8%		

ENSURING A VALID RESET OUTPUT DOWN TO $V_{\text{CC}} = 0\text{V}$

When V_{CC} falls below 1V, the LM3722 $\overline{\text{RESET}}$ output is unable to sink the rated current. A high-impedance CMOS logic input connected to $\overline{\text{RESET}}$ can therefore drift to undetermined voltages. To prevent this situation, a 100k Ω resistor should be connected from the $\overline{\text{RESET}}$ output to ground, as shown in Figure 13.

A 100k Ω pull-up resistor to V_{CC} is also recommended for the LM3723, if RESET is required to remain valid for $V_{\text{CC}} < 1\text{V}$.



Figure 13. Circuit for $\overline{\text{RESET}}$ Valid from $V_{\text{CC}} = 0\text{V}$

OPEN DRAIN OUTPUT (LM3724)

An open drain output allows easy paralleling of multiple microprocessor reset circuits without requiring additional logic gates. Open drain outputs also allow interfacing devices of differing logic levels or families, since the output pull-up resistor may be connected to any supply voltage up to 5.5V, regardless of LM3724 V_{CC} .

The pull up resistor is calculated so that maximum current flow into $\overline{\text{RESET}}$ is less than 10 mA when activated. The resistor must be small enough so that the leakage current of all connected devices does not create an excessive voltage drop when the output is not activated. A resistor value of 100 k Ω will generally suffice.

NEGATIVE-GOING V_{CC} TRANSIENTS

The LM3722/LM3723/LM3724 are relatively immune to short negative-going transients or glitches on V_{CC} . Figure 14 shows the maximum pulse width a negative-going V_{CC} transient can have without causing a reset pulse. In general, as the magnitude of the transient increases, going further below the reset threshold, the maximum allowable pulse width decreases. Typically, a V_{CC} transient that goes 125 mV below the reset threshold and lasts 40 μ s or less will not cause a reset pulse. A 0.1 μ F bypass capacitor mounted as close as possible to the V_{CC} pin will provide additional transient rejection.

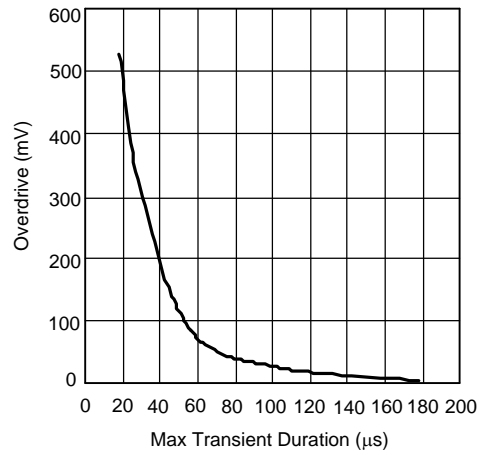

Figure 14. Maximum Transient Duration without Causing a Reset Pulse vs. Reset Comparator Overdrive

INTERFACING TO μ PS WITH BIDIRECTIONAL RESET PINS

Microprocessors with bidirectional reset pins, such as the Motorola 68HC11 series, can be connected to the LM3722 even when the microprocessor reset pin is in the opposite state, connect a 4.7k Ω resistor between the LM3722 RESET output and the μ P reset pin, as shown in Figure 15. Buffer the LM3722 RESET output to other system components.

Typical Application Circuits

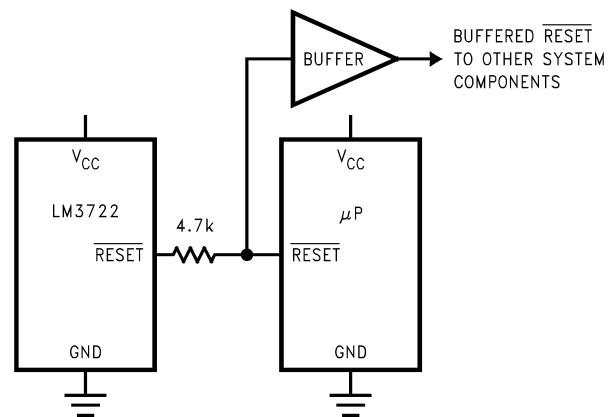

Figure 15. Interfacing to Microprocessors with Bidirectional Reset I/O



Figure 16. Regulator/Switch with Long-Term Overvoltage Lockout Prevents Overdissipation in Linear Regulator



Figure 17. LM3722 Switch Debouncer

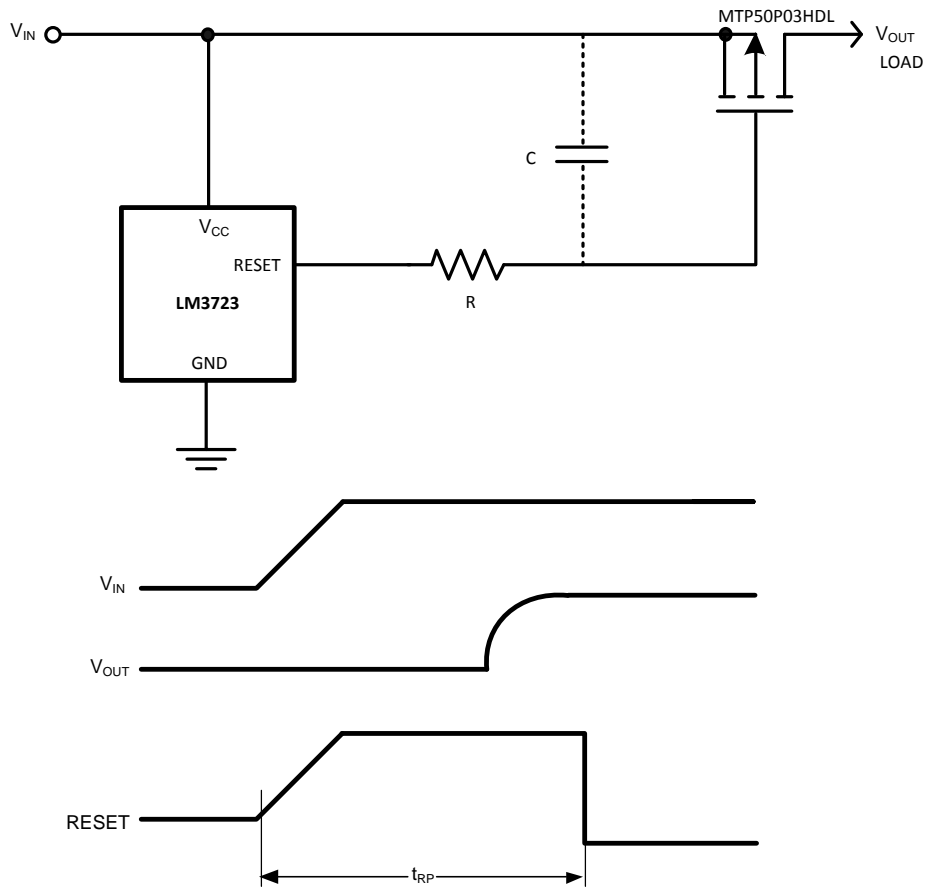

Figure 18. LM3723 Power-On Delay

REVISION HISTORY

Changes from Revision D (March 2013) to Revision E	Page
• Changed layout of National Data Sheet to TI format	11

PACKAGING INFORMATION

Orderable Device	Status (1)	Package Type	Package Drawing	Pins	Package Qty	Eco Plan (2)	Lead/Ball Finish (6)	MSL Peak Temp (3)	Op Temp (°C)	Device Marking (4/5)	Samples
LM3724EM5-3.08/NOPB	ACTIVE	SOT-23	DBV	5	1000	Green (RoHS & no Sb/Br)	CU SN	Level-1-260C-UNLIM	-40 to 125	R63B	Samples
LM3724EM5-4.63/NOPB	ACTIVE	SOT-23	DBV	5	1000	Green (RoHS & no Sb/Br)	CU SN	Level-1-260C-UNLIM	-40 to 125	R62B	Samples
LM3724IM5-2.32/NOPB	ACTIVE	SOT-23	DBV	5	1000	Green (RoHS & no Sb/Br)	CU SN	Level-1-260C-UNLIM	-40 to 85	R50B	Samples
LM3724IM5-3.08/NOPB	ACTIVE	SOT-23	DBV	5	1000	Green (RoHS & no Sb/Br)	CU SN	Level-1-260C-UNLIM	-40 to 85	R53B	Samples
LM3724IM5-4.63/NOPB	ACTIVE	SOT-23	DBV	5	1000	Green (RoHS & no Sb/Br)	CU SN	Level-1-260C-UNLIM	-40 to 85	R55B	Samples
LM3724IM5X-3.08/NOPB	ACTIVE	SOT-23	DBV	5	3000	Green (RoHS & no Sb/Br)	CU SN	Level-1-260C-UNLIM	-40 to 85	R53B	Samples

(1) The marketing status values are defined as follows:

ACTIVE: Product device recommended for new designs.

LIFEBUY: TI has announced that the device will be discontinued, and a lifetime-buy period is in effect.

NRND: Not recommended for new designs. Device is in production to support existing customers, but TI does not recommend using this part in a new design.

PREVIEW: Device has been announced but is not in production. Samples may or may not be available.

OBSOLETE: TI has discontinued the production of the device.

(2) Eco Plan - The planned eco-friendly classification: Pb-Free (RoHS), Pb-Free (RoHS Exempt), or Green (RoHS & no Sb/Br) - please check <http://www.ti.com/productcontent> for the latest availability information and additional product content details.

TBD: The Pb-Free/Green conversion plan has not been defined.

Pb-Free (RoHS): TI's terms "Lead-Free" or "Pb-Free" mean semiconductor products that are compatible with the current RoHS requirements for all 6 substances, including the requirement that lead not exceed 0.1% by weight in homogeneous materials. Where designed to be soldered at high temperatures, TI Pb-Free products are suitable for use in specified lead-free processes.

Pb-Free (RoHS Exempt): This component has a RoHS exemption for either 1) lead-based flip-chip solder bumps used between the die and package, or 2) lead-based die adhesive used between the die and leadframe. The component is otherwise considered Pb-Free (RoHS compatible) as defined above.

Green (RoHS & no Sb/Br): TI defines "Green" to mean Pb-Free (RoHS compatible), and free of Bromine (Br) and Antimony (Sb) based flame retardants (Br or Sb do not exceed 0.1% by weight in homogeneous material)

(3) MSL, Peak Temp. - The Moisture Sensitivity Level rating according to the JEDEC industry standard classifications, and peak solder temperature.

(4) There may be additional marking, which relates to the logo, the lot trace code information, or the environmental category on the device.

(5) Multiple Device Markings will be inside parentheses. Only one Device Marking contained in parentheses and separated by a "~" will appear on a device. If a line is indented then it is a continuation of the previous line and the two combined represent the entire Device Marking for that device.

⁽⁶⁾ Lead/Ball Finish - Orderable Devices may have multiple material finish options. Finish options are separated by a vertical ruled line. Lead/Ball Finish values may wrap to two lines if the finish value exceeds the maximum column width.

Important Information and Disclaimer: The information provided on this page represents TI's knowledge and belief as of the date that it is provided. TI bases its knowledge and belief on information provided by third parties, and makes no representation or warranty as to the accuracy of such information. Efforts are underway to better integrate information from third parties. TI has taken and continues to take reasonable steps to provide representative and accurate information but may not have conducted destructive testing or chemical analysis on incoming materials and chemicals. TI and TI suppliers consider certain information to be proprietary, and thus CAS numbers and other limited information may not be available for release.

In no event shall TI's liability arising out of such information exceed the total purchase price of the TI part(s) at issue in this document sold by TI to Customer on an annual basis.

TAPE AND REEL INFORMATION

QUADRANT ASSIGNMENTS FOR PIN 1 ORIENTATION IN TAPE

*All dimensions are nominal

Device	Package Type	Package Drawing	Pins	SPQ	Reel Diameter (mm)	Reel Width W1 (mm)	A0 (mm)	B0 (mm)	K0 (mm)	P1 (mm)	W (mm)	Pin1 Quadrant
LM3724EM5-3.08/NOPB	SOT-23	DBV	5	1000	178.0	8.4	3.2	3.2	1.4	4.0	8.0	Q3
LM3724EM5-4.63/NOPB	SOT-23	DBV	5	1000	178.0	8.4	3.2	3.2	1.4	4.0	8.0	Q3
LM3724IM5-2.32/NOPB	SOT-23	DBV	5	1000	178.0	8.4	3.2	3.2	1.4	4.0	8.0	Q3
LM3724IM5-3.08/NOPB	SOT-23	DBV	5	1000	178.0	8.4	3.2	3.2	1.4	4.0	8.0	Q3
LM3724IM5-4.63/NOPB	SOT-23	DBV	5	1000	178.0	8.4	3.2	3.2	1.4	4.0	8.0	Q3
LM3724IM5X-3.08/NOPB	SOT-23	DBV	5	3000	178.0	8.4	3.2	3.2	1.4	4.0	8.0	Q3

TAPE AND REEL BOX DIMENSIONS

*All dimensions are nominal

Device	Package Type	Package Drawing	Pins	SPQ	Length (mm)	Width (mm)	Height (mm)
LM3724EM5-3.08/NOPB	SOT-23	DBV	5	1000	210.0	185.0	35.0
LM3724EM5-4.63/NOPB	SOT-23	DBV	5	1000	210.0	185.0	35.0
LM3724IM5-2.32/NOPB	SOT-23	DBV	5	1000	210.0	185.0	35.0
LM3724IM5-3.08/NOPB	SOT-23	DBV	5	1000	210.0	185.0	35.0
LM3724IM5-4.63/NOPB	SOT-23	DBV	5	1000	210.0	185.0	35.0
LM3724IM5X-3.08/NOPB	SOT-23	DBV	5	3000	210.0	185.0	35.0

DBV (R-PDSO-G5)

PLASTIC SMALL-OUTLINE PACKAGE

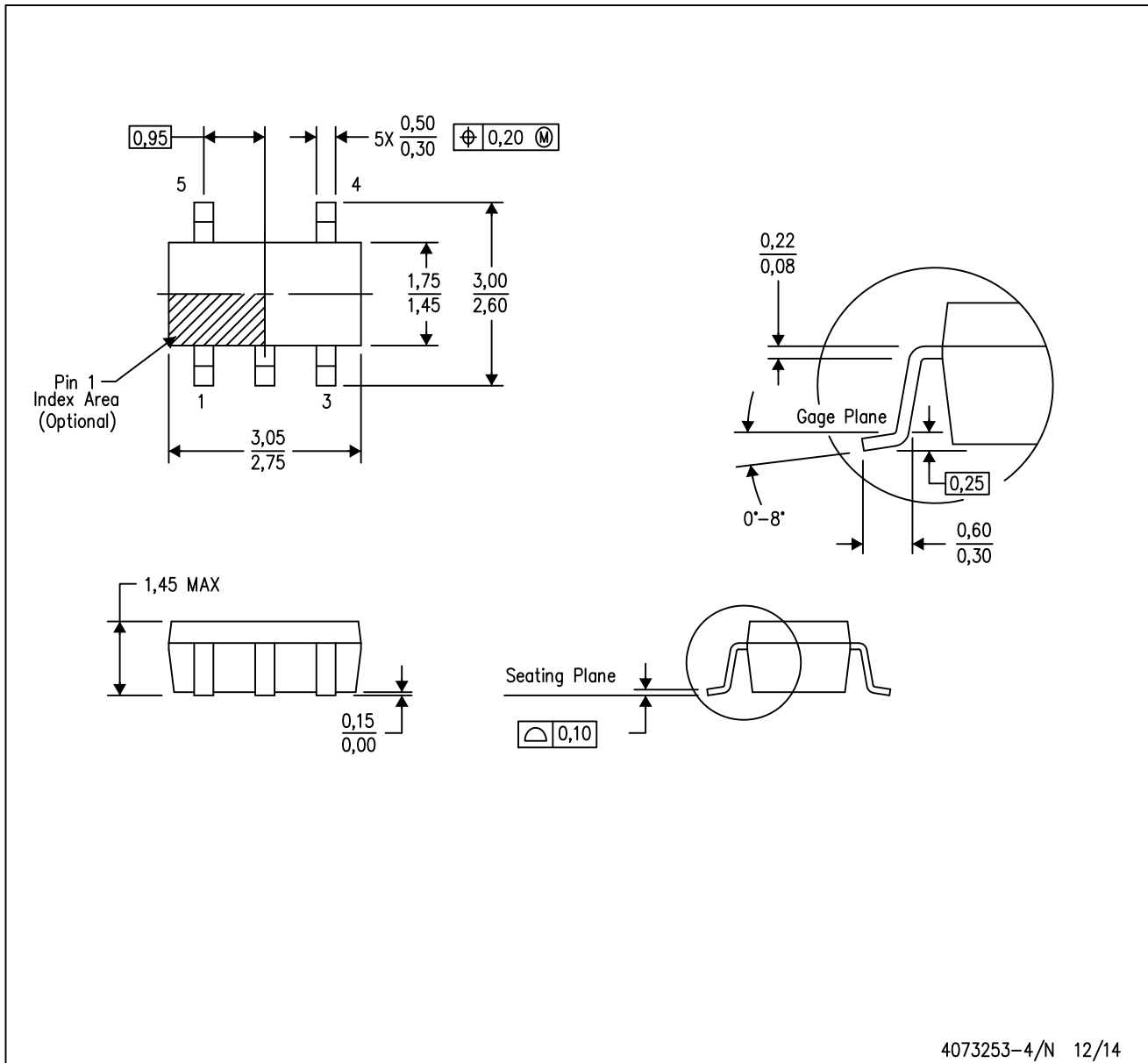

- NOTES:
- A. All linear dimensions are in millimeters.
 - B. This drawing is subject to change without notice.
 - C. Body dimensions do not include mold flash or protrusion. Mold flash and protrusion shall not exceed 0.15 per side.
 - D. Falls within JEDEC MO-178 Variation AA.

DBV (R-PDSO-G5)

PLASTIC SMALL OUTLINE



- NOTES:
- A. All linear dimensions are in millimeters.
 - B. This drawing is subject to change without notice.
 - C. Customers should place a note on the circuit board fabrication drawing not to alter the center solder mask defined pad.
 - D. Publication IPC-7351 is recommended for alternate designs.
 - E. Laser cutting apertures with trapezoidal walls and also rounding corners will offer better paste release. Customers should contact their board assembly site for stencil design recommendations. Example stencil design based on a 50% volumetric metal load solder paste. Refer to IPC-7525 for other stencil recommendations.

IMPORTANT NOTICE

Texas Instruments Incorporated and its subsidiaries (TI) reserve the right to make corrections, enhancements, improvements and other changes to its semiconductor products and services per JESD46, latest issue, and to discontinue any product or service per JESD48, latest issue. Buyers should obtain the latest relevant information before placing orders and should verify that such information is current and complete. All semiconductor products (also referred to herein as "components") are sold subject to TI's terms and conditions of sale supplied at the time of order acknowledgment.

TI warrants performance of its components to the specifications applicable at the time of sale, in accordance with the warranty in TI's terms and conditions of sale of semiconductor products. Testing and other quality control techniques are used to the extent TI deems necessary to support this warranty. Except where mandated by applicable law, testing of all parameters of each component is not necessarily performed.

TI assumes no liability for applications assistance or the design of Buyers' products. Buyers are responsible for their products and applications using TI components. To minimize the risks associated with Buyers' products and applications, Buyers should provide adequate design and operating safeguards.

TI does not warrant or represent that any license, either express or implied, is granted under any patent right, copyright, mask work right, or other intellectual property right relating to any combination, machine, or process in which TI components or services are used. Information published by TI regarding third-party products or services does not constitute a license to use such products or services or a warranty or endorsement thereof. Use of such information may require a license from a third party under the patents or other intellectual property of the third party, or a license from TI under the patents or other intellectual property of TI.

Reproduction of significant portions of TI information in TI data books or data sheets is permissible only if reproduction is without alteration and is accompanied by all associated warranties, conditions, limitations, and notices. TI is not responsible or liable for such altered documentation. Information of third parties may be subject to additional restrictions.

Resale of TI components or services with statements different from or beyond the parameters stated by TI for that component or service voids all express and any implied warranties for the associated TI component or service and is an unfair and deceptive business practice. TI is not responsible or liable for any such statements.

Buyer acknowledges and agrees that it is solely responsible for compliance with all legal, regulatory and safety-related requirements concerning its products, and any use of TI components in its applications, notwithstanding any applications-related information or support that may be provided by TI. Buyer represents and agrees that it has all the necessary expertise to create and implement safeguards which anticipate dangerous consequences of failures, monitor failures and their consequences, lessen the likelihood of failures that might cause harm and take appropriate remedial actions. Buyer will fully indemnify TI and its representatives against any damages arising out of the use of any TI components in safety-critical applications.

In some cases, TI components may be promoted specifically to facilitate safety-related applications. With such components, TI's goal is to help enable customers to design and create their own end-product solutions that meet applicable functional safety standards and requirements. Nonetheless, such components are subject to these terms.

No TI components are authorized for use in FDA Class III (or similar life-critical medical equipment) unless authorized officers of the parties have executed a special agreement specifically governing such use.

Only those TI components which TI has specifically designated as military grade or "enhanced plastic" are designed and intended for use in military/aerospace applications or environments. Buyer acknowledges and agrees that any military or aerospace use of TI components which have **not** been so designated is solely at the Buyer's risk, and that Buyer is solely responsible for compliance with all legal and regulatory requirements in connection with such use.

TI has specifically designated certain components as meeting ISO/TS16949 requirements, mainly for automotive use. In any case of use of non-designated products, TI will not be responsible for any failure to meet ISO/TS16949.

Products

Audio	www.ti.com/audio
Amplifiers	amplifier.ti.com
Data Converters	dataconverter.ti.com
DLP® Products	www.dlp.com
DSP	dsp.ti.com
Clocks and Timers	www.ti.com/clocks
Interface	interface.ti.com
Logic	logic.ti.com
Power Mgmt	power.ti.com
Microcontrollers	microcontroller.ti.com
RFID	www.ti-rfid.com
OMAP Applications Processors	www.ti.com/omap
Wireless Connectivity	www.ti.com/wirelessconnectivity

Applications

Automotive and Transportation	www.ti.com/automotive
Communications and Telecom	www.ti.com/communications
Computers and Peripherals	www.ti.com/computers
Consumer Electronics	www.ti.com/consumer-apps
Energy and Lighting	www.ti.com/energy
Industrial	www.ti.com/industrial
Medical	www.ti.com/medical
Security	www.ti.com/security
Space, Avionics and Defense	www.ti.com/space-avionics-defense
Video and Imaging	www.ti.com/video

TI E2E Community

e2e.ti.com

Looking for pricing, stock, or lifecycle information?

Click below to explore more details on WIN SOURCE:

 [View LM3722IM5-2.32/NOPB on WIN SOURCE](#)

 [Texas Instruments](#) Information

Optimize Your Supply Chain with WIN SOURCE Solutions

-  Global Sourcing Solution
-  Obsolete Management
-  Cost Control Management
-  Shortage Management
-  Alternative Solution
-  Excess Inventory Management