



**THE DATASHEET OF
LP3913SQ-AE/NOPB**



LP3913 Power Management IC for Flash Memory-Based Portable Media Players

Check for Samples: [LP3913](#)

FEATURES

- 2 Low-Dropout Regulators -- LDO1 is Used for General Purpose Applications, LDO2 is Used for Low-Noise Analog Applications. Both LDOs Have Programmable Output Voltages.
- Green and Red LED Charger Status Drivers
- 4-Channel 8-Bit Dual Slope A/D Converter
- 3 High-Efficiency DVS Buck Converters
- 400 kHz I²C Compatible Interface
- Linear Constant-Current/Constant-Voltage Charger for Single Cell Lithium-Ion Batteries
- USB and Adapter Charging
- System Power Supply Management
- 6x6 x 0.8 mm 48 WQFN Package
- Voltage and Thermal Supervisory Circuits
- Continuous Battery Voltage Monitoring
- Interrupt Request Output with 8 Sources
- LP3913 is Pin-for-Pin and Software-Compatible with the LP3910 Hard Drive Based PMIC

KEY SPECIFICATIONS

- LDO1: 150 mA, 1.2V–3.3V
- LDO2: 150 mA, 1.3V–3.3V
- Buck1: 600 mA, 0.8V–2.0V
- Buck2: 600 mA, 1.8V–3.3V
- Buck3: 500 mA, 1.8V–3.3V
- 50 mΩ Battery Path Resistance
- 100 mA to 1000 mA Full-Rate Charge Current Using Wall Adapter
- Selectable 0.05C and 0.1C EOC Current
- USB Current Limit of 100 mA, 500 mA, and 800 mA
- USB Pre-Qual Current of 50 mA
- Selectable 4.1V, 4.2V or 4.38V battery termination voltages
- 0.35% Battery Termination Accuracy
- ±1 LSB INL/DNL on 8-bit A/D Converter

APPLICATIONS

- Flash-Based Portable Media Players
- Portable Gaming Devices
- Portable Navigation Systems

DESCRIPTION

The LP3913 is a programmable system power management unit that is optimized for Flash Memory based Portable Media Players.

The LP3913 incorporates 2 low-dropout LDO voltage regulators, 3 integrated Buck DC/DC converters with Dynamic Voltage Scaling (DVS), a 4-channel 8-bit A/D converter, and a dual source Li-Ion/polymer battery charger. The charger has the capability to charge and maintain a single cell battery from a regulated wall adapter or USB power. When both USB and adapter sources are present, then the adapter source takes precedence and switching between USB and adapter power sources is seamless. In addition, the battery charger supports power routing, which allows system usage immediately after an external power source has been detected. The LP3913 also incorporates some advanced battery management functions such as battery temperature measurement, reverse current blocking for USB, LED charger status indication, thermally regulated internal power FETs, battery voltage monitoring, over-current protection and a 10-hour safety timer.

The 4-channel A/D converter measures the battery voltage and charge current, which can be used for fuel gauging. Two undedicated channels can be used to measure other analog parameters such as discharge current, battery temperature, keyboard resistor scanning and more.

The various IC parameters are programmable through a 400 kHz I²C compatible interface.

The LP3913 is available in a thermally-enhanced 6x6x0.8 mm 48 WQFN package and operates over an ambient temperature range of –40°C to +85°C.



Please be aware that an important notice concerning availability, standard warranty, and use in critical applications of Texas Instruments semiconductor products and disclaimers thereto appears at the end of this data sheet.

All trademarks are the property of their respective owners.

TYPICAL APPLICATION CIRCUIT

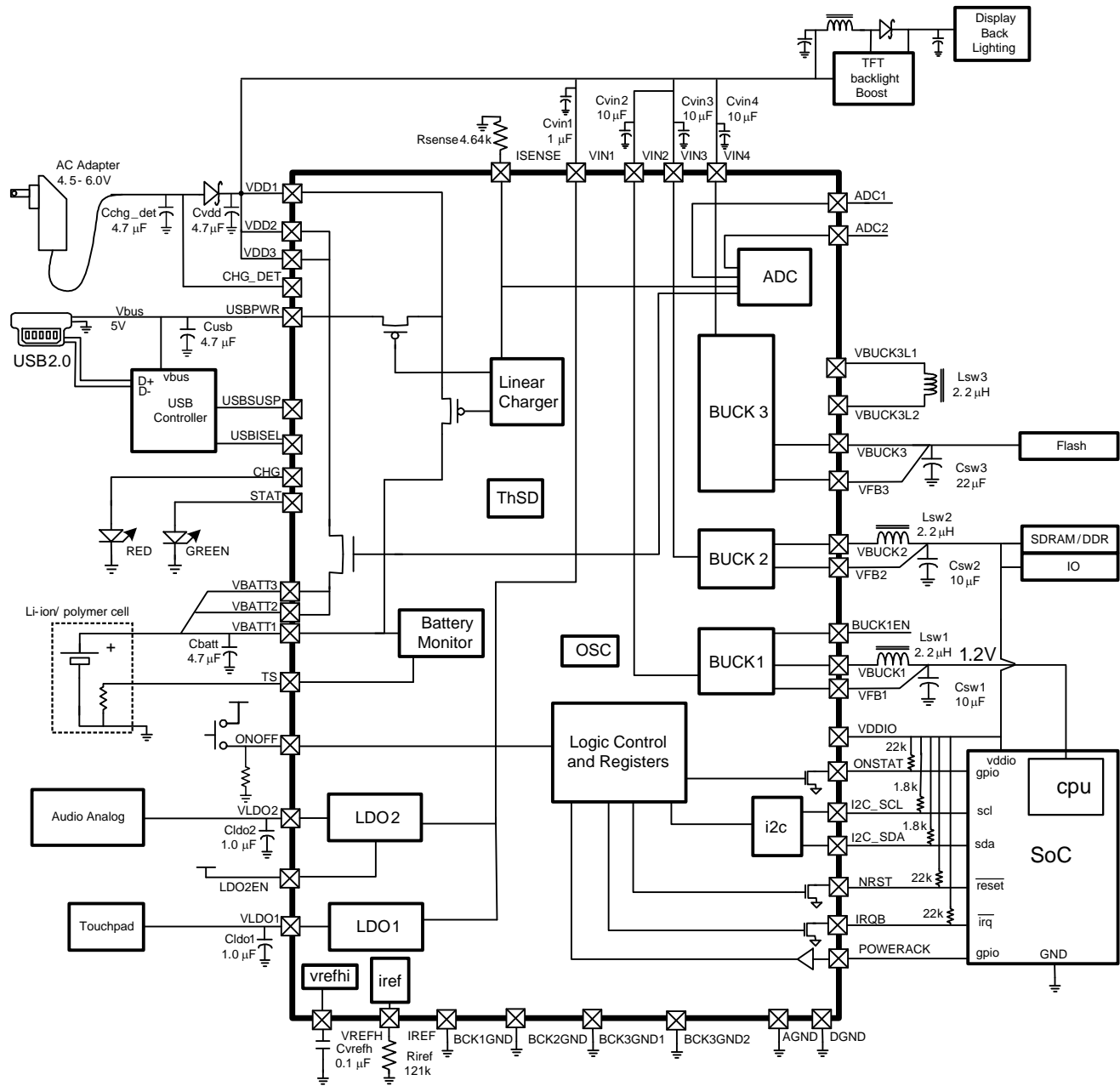

Connection Diagram

Device Connection Diagram

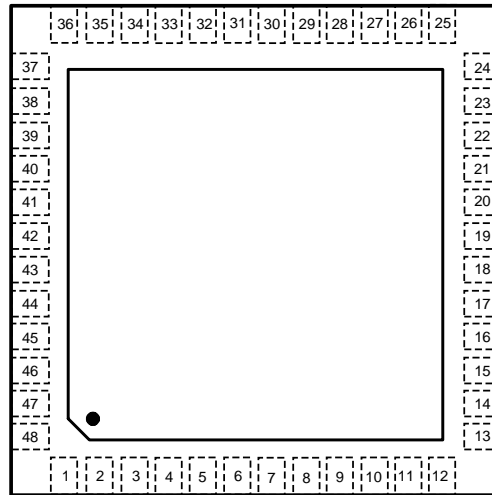

Figure 1. 48 WQFN Package (Top View)
Package Number NJV0048A

Table 1. Additional Application Information

Part Number	LDO1 (V)	LDO2 (V)	Buck1 (V)	Buck2 (V)	Buck 3 (V)	ICHRG (mA)
LP3913SQ-AA/LP3913SQX-AA	2.00	3.30	1.20	3.30	3.30	100
LP3913SQ-AC/LP3913SQX-AC	1.30	3.30	1.30	1.80	3.30	100
LP3913SQ-AD/LP3913SQX-AD	2.00	3.30	1.20	1.80	3.30	100
LP3913SQ-ADJ/LP3913SQX-ADJ	1.80	3.30	ADJ	ADJ	3.30	100
LP3913SQ-AE/LP3913SQX-AE	1.30	3.30	1.30	3.30	3.30	100
LP3913SQ-AR/LP3913SQX-AR	1.80	3.30	1.20	1.80	3.30	1000

Pin Descriptions

Pin #	Name	I/O	Type	Functional Description
1	TS	I	A	Battery temperature sense pin. This pin is normally connected to the thermistor pin of the battery cell.
2	VBATT1	O	A	Positive battery terminal. This pin must be externally shorted to VBATT2 and VBATT3
3	AGND	G	G	Analog Ground
4	VREFH	O	A	Connection to bypass capacitor for internal high reference
5	LDO2EN	I	D	Digital input to enable/disable LDO2
6	VLDO2	O	A	LDO2 Output
7	VIN1	I	PWR	Power input to LDO1 and LDO2. VIN1 pin must be externally shorted to the VDD pins.
8	VLDO1	O	A	LDO1 Output
9	POWERACK	I	D	Digital power acknowledgment input (see Power On/Off Sequencing)
10	ISENSE	I	A	A 4.64-kΩ resistor must be connected between this pin and GND. A fraction of the charge current flows through this resistor to enable the A to D converter to measure the charge current.
11	ADC2	I	A	Channel 2 input to AD converter
12	ADC1	I	A	Channel 1 input to AD converter
13	IRQB	O	Open Drain	Open drain active low interrupt request

Pin #	Name	I/O	Type	Functional Description
14	NRST	O	Open Drain	Open drain active low reset during Standby
15	CHG	O	D	This output indicates that a valid charger supply source (USB adapter) has been detected, and the IC is charging. (Red LED)
16	STAT	O	D	Battery Status output indicator - Off during CC, 50% duty cycle during CV, 100% duty cycle with a fully charged Li-ion battery (Green LED)
17	BUCK1EN	I	D	Digital input to enable/disable BUCK1
18	VFB1	I	A	Buck1 Feedback input terminal
19	BCKGND1	G	G	Buck1 Ground
20	VBUCK1	O	A	Buck1 Output
21	VIN2	I	PWR	Power input to BUCK1. VIN2 pin must be externally shorted to the VDD pins.
22	VIN3	I	PWR	Power input to BUCK2. VIN3 pin must be externally shorted to the VDD pins.
23	VBUCK2	O	A	Buck2 Output
24	BCKGND2	G	G	Buck2 Ground
25	VFB2	I	A	Buck2 Feedback input terminal
26	ONOFF	I	D	Power ON/OFF pin configured either as level (High or Low) triggered or edge (High or Low) triggered.
27	I ² C_SCL	I	D	I ² C-compatible interface clock terminal
28	VDDIO	I	D	Supply to input / output stages of digital I/O
29	I ² C_SDA	I/O	D	I ² C-compatible interface data terminal
30	ONSTAT	O	Open Drain	Open Drain output that reflects the debounced state of ONOFF pin.
31	VFB3	I	A	Buck3 Feedback input terminal
32	VBUCK3	O	A	Buck3 Output voltage
33	VBUCK3L2	I	A	Buck3 inductor
34	BCK3GND1	G	G	Buck3t high current ground
35	VBUCK3L1	I	A	Buck3 inductor
36	VIN4	I	PWR	Power input to Buck3. VIN4 pin must be externally shorted to the VDD pins.
37	USBSUSP	I	D	This pin needs to be pulled high during USB suspend mode.
38	USBISEL	I	D	Pulling this pin low limits the USB charge current to 100 mA. Pulling this pin high limits the USB charge current to 500 mA.
39	BUCK3GND2	G	G	Buck3 Core Ground
40	DGND	G	G	Digital ground
41	VDD3	I	PWR	Power input to supply application. This pin must be externally shorted to VDD1 and VDD2.
42	VDD2	I	PWR	Power input to supply application This pin must be externally shorted to VDD1 and VDD3.
43	VBATT3	O	A	Positive battery terminal. This pin must be externally shorted to VBATT1 and VBATT2.
44	VBATT2	O	A	Positive battery terminal. This pin must be externally shorted to VBATT1 and VBATT3.
45	USBPWR	I	PWR	USB power input pin
46	VDD1	I	PWR	Power input to supply application This pin is shorted to VDD2 and VDD3.
47	CHG_DET	I	A	Wall adapter power input pin
48	IREF	I	A	A 121 kΩ resistor must be connected between this pin and AGND. The resistor value determines the reference current for the internal bias generator.

A: Analog Pin **D:** Digital Pin **G:** Ground Pin **PWR:** Power Pin **I:** Input Pin **I/O:** Input/Output Pin **O:** Output Pin



These devices have limited built-in ESD protection. The leads should be shorted together or the device placed in conductive foam during storage or handling to prevent electrostatic damage to the MOS gates.

ABSOLUTE MAXIMUM RATINGS ^{(1) (2)(3)(4)}

Supply voltage range CHG_DET	-0.3V to +6.5V
Voltage range USBPWR, VIN1, VIN2, VIN3, VIN4, VDD1, VDD2, VDD3	-0.3V to +6.2V
Battery voltage range VBATT1, 2, 3	-0.3V to +5V
All other pins	-0.3V to VDD +0.3V
Storage Temperature Range	-45°C to +150°C
Power Dissipation ($T_A = 70^\circ\text{C}$ ⁽⁵⁾):	2.6W
ESD Rating ⁽⁶⁾	
Human Body Model:	2.0 kV
Machine Model:	200V

- (1) Absolute Maximum Ratings indicate limits beyond which damage to the component may occur. Operating Ratings are conditions under which operation of the device is specified. Operating Ratings do not imply performance limits. For performance limits and associated test conditions, see the Electrical Characteristics tables.
- (2) All voltages are with respect to the potential at the GND pin.
- (3) In applications where high power dissipation and/or poor package thermal resistance is present, the maximum ambient temperature may have to be derated. Maximum ambient temperature (T_{A-MAX}) is dependent on the maximum operating junction temperature ($T_{J-MAX-OP} = 125^\circ\text{C}$), the maximum power dissipation of the device in the application (P_{D-MAX}), and the junction-to-ambient thermal resistance of the part/package in the application (θ_{JA}), as given by the following equation: $T_{A-MAX} = T_{J-MAX-OP} - (\theta_{JA} \times P_{D-MAX})$.
- (4) If Military/Aerospace specified devices are required, please contact the TI Sales Office/Distributors for availability and specifications.
- (5) Internal thermal shutdown circuitry protects the device from permanent damage. Thermal shutdown engages at $T_J = 160^\circ\text{C}$ (typ.) and disengages at $T_J = 140^\circ\text{C}$ (typ.).
- (6) The Human body model is a 100 pF capacitor discharged through a 1.5 k Ω resistor into each pin. The machine model is a 200 pF capacitor discharged directly into each pin. MIL-STD-883 3015.7.

RECOMMENDED OPERATING CONDITIONS ^{(1) (2) (3)}

CHG_DET	4.5V to 6.0V
USBPWR	4.35V to 6.0V
VBATT1, 2, 3	0V to 4.5V
VIN1, VIN2, VIN3, VIN4, VDD1, VDD2, VDD3	2.5V to 6.0V
VDDIO	2.5V to VDD
Junction Temperature (T_J) Range	-40°C to +125°C
Ambient Temperature (T_A) Range	-40°C to +85°C
Power Dissipation for T_{JMAX} and T_{AMAX}	1.6W

- (1) Junction-to-ambient thermal resistance is highly application and board-layout dependent. In applications where high maximum power dissipation exists, special care must be paid to thermal dissipation issues in board design.
- (2) Min and Max limits are specified by design, test, or statistical analysis. Typical numbers represent the most likely norm.
- (3) Typical values and limits appearing in normal type for $T_J = 25^\circ\text{C}$. Limits appearing in **boldface type** apply over the entire junction temperature range for operation, -40°C to +125°C.

THERMAL INFORMATION ⁽¹⁾

Junction-to-Ambient Thermal Resistance (θ_{JA}), 48-pin WQFN NJV0048A Package ⁽²⁾	25°C/W
--	--------

- (1) In applications where high power dissipation and/or poor package thermal resistance is present, the maximum ambient temperature may have to be derated. Maximum ambient temperature (T_{A-MAX}) is dependent on the maximum operating junction temperature ($T_{J-MAX-OP} = 125^\circ\text{C}$), the maximum power dissipation of the device in the application (P_{D-MAX}), and the junction-to-ambient thermal resistance of the part/package in the application (θ_{JA}), as given by the following equation: $T_{A-MAX} = T_{J-MAX-OP} - (\theta_{JA} \times P_{D-MAX})$.
- (2) Min and Max limits are specified by design, test, or statistical analysis. Typical numbers represent the most likely norm.

GENERAL ELECTRICAL CHARACTERISTICS

Unless otherwise noted, VDD = 5V, VBATT = 3.6V. Typical values and limits appearing in normal type apply for T_J = 25°C. Limits appearing in **boldface type** apply over the entire junction temperature range for operation, T_J = 0°C to +125°C.
(1)(2)(3)(4)

Symbol	Parameter	Conditions	Min	Typ	Max	Units
I _{Q_BATT}	Battery Standby Supply Current	All circuits off except for POR and battery monitor. No adapter or USB power connected.		6	20	μA
V _{POR}	Power-On Reset Threshold	VDD Falling Edge		1.9		V
T _{SD}	Thermal Shutdown Threshold			160		°C
T _{SDH}	Thermal Shutdown Hysteresis			20		°C
T _{TH-ALERT}	Thermal Interrupt Threshold			115		°C
V _{DDIO}	IO Supply		2.5		V _{DD}	V
F _{CLK}	Internal System Clock Frequency			2		MHz

- (1) All voltages are with respect to the potential at the GND pin.
- (2) Min and Max limits are specified by design, test, or statistical analysis. Typical numbers represent the most likely norm.
- (3) Low ESR Surface-Mount Ceramic Capacitors (MLCCs) are used in setting electrical characteristics.
- (4) Specified by design. Not production tested

I²C INTERFACE ELECTRICAL CHARACTERISTICS

Unless otherwise noted, V_{DDIO} = 3.6V. Typical values and limits appearing in normal type apply for T_J = 25°C. Limits appearing in **boldface type** apply over the entire junction temperature range for operation, T_J = 0°C to +125°C.⁽¹⁾⁽²⁾⁽³⁾⁽⁴⁾

Symbol	Parameter	Conditions	Min	Typ	Max	Units
V _{IL}	Low Level Input Voltage	I ² C_SDA & I ² C_SCL			0.3VDDIO	V
V _{IH}	High Level Input Voltage	I ² C_SDA & I ² C_SCL	0.7VDDIO			V
V _{OL}	Low Level Output Voltage	I ² C_SDA & I ² C_SCL	0		0.2VDDIO	V
V _{HYS}	Schmitt Trigger Input Hysteresis	I ² C_SDA & I ² C_SCL	0.1VDDIO			V
F _{CLK}	Clock Frequency				400	kHz
t _{BF}	Bus-Free Time between START and STOP	(4)	1.3			μs
t _{HOLD}	Hold Time Repeated START Condition	(4)	0.6			μs
t _{CLK-LP}	CLK Low Period	(4)	1.3			μs
t _{CLK-HP}	CLK High Period	(4)	0.6			μs
t _{SU}	Set-up Time Repeated START Condition	(4)	0.6			μs
t _{DATA-HOLD}	Data Hold Time	(4)	0			μs
t _{DATA-SU}	Data Set-up Time	(4)	100			ns
t _{SU}	Set-Up Time for STOP Condition	(4)	0.6			μs
t _{TRANS}	Maximum Pulse Width of Spikes That Must Be Suppressed by the Input Filter of Both Data and CLK Signals.	(4)	50			μs

- (1) All voltages are with respect to the potential at the GND pin.
- (2) Min and Max limits are specified by design, test, or statistical analysis. Typical numbers represent the most likely norm.
- (3) Low ESR Surface-Mount Ceramic Capacitors (MLCCs) are used in setting electrical characteristics.
- (4) Specified by design. Not production tested.

LI-ION BATTERY CHARGER ELECTRICAL CHARACTERISTICS

Unless otherwise noted, $V_{DD} = 5.0V$, $V_{BATT} = 3.6V$, $C_{BATT} = 4.7 \mu F$, $C_{CHG_DET} = 10 \mu F$, $R_{IREF} = 121 k\Omega$. Typical values and limits appearing in normal type apply for $T_J = 25^\circ C$. Limits appearing in **boldface type** apply over the entire junction temperature range for operation, $T_J = 0^\circ C$ to $+125^\circ C$. ⁽¹⁾⁽²⁾⁽³⁾⁽⁴⁾⁽⁵⁾

Symbol	Parameter	Conditions	Min	Typ	Max	Units
V_{USB}	Minimum External USB Supply Voltage	USB Current Limit = 500 mA	4.15	4.25	4.35	V
V_{USB_HYST}	USBPWR Detect Hysteresis			50		mV
CHG_DET	Minimum External Adapter Supply Voltage Range	Adapter Current Limit = 1A V_{FWD} Schottky = 350 mV	4.4	4.5	4.6	V
V_{CHG_HYST}	CHG_DET Input Hysteresis			150		mV
I_{USB_SUSP}	Quiescent Current in USB Suspend Mode	USB Suspend Mode, $V_{USB} = 5.0V$ USBSUSP = USBPWR USBISEL = 0V		30	60	μA
V_{TERM_TOL}	Battery Charge Termination Voltage Tolerance	$T_A = 25^\circ C$, $I_{PROG} = 500$ mA $I_{CHG} = 50$ mA	-0.35 -0.5 -0.5	4.2V 4.1V 4.38V	+0.35 +0.5 +0.5	%
		$T_A = 0^\circ C$ to $125^\circ C$, $I_{PROG} = 500$ mA, $I_{CHG} = 50$ mA	-1 -1.5 -1.5	4.2V 4.1V 4.38V	+1 +1.5 +1.5	
I_{CHG_WA}	Full-rate Charging Current from Wall Adapter Input (See Full-Rate Charging Mode)	CHG_DET = 5.25V $V_{BATT} = 3.6V$ $I_{PROG} = 500$ mA	450	500	550	mA
I_{CHG_USB}	Full-rate Charging Current from USBPWR Input (See Full-Rate Charging Mode)	USB = 5V $V_{BATT} = 3.6V$ $I_{PROG} = 500$ mA USB_ISEL = 800 mA	450	500	550	mA
		USB = 5V $V_{BATT} = 3.6V$ $I_{PROG} = 500$ mA USB_ISEL = 500 mA	405	450	495	mA
USB I_{LIMIT}		USB_ISEL = 100 mA	90	95	100	mA
		USB_ISEL = 500 mA	450	475	500	
		USB_ISEL = 800 mA	720	760	800	
$I_{PREQUAL}$	Pre-qualification Current	$V_{BATT} = 2.5V$, Wall Adapter Charge Current. Percentage of Programmed Full Rate Current.	8	10	12	%
		$V_{BATT} = 2.5V$, USB Charge Current	40	50	60	mA
V_{FULL_RATE}	Full-rate Qualification Threshold	V_{BATT} Rising, Transition from Pre-Qualification to Full-rate Charging	2.75	2.85	2.95	V
V_{TH_H}	Upper T_S Comparator Limit		2.82	2.87	2.93	V
V_{TH_L}	Lower T_S Comparator Limit	45°C CHSPV Reg D3 = 0	0.315	0.33	0.345	V
		50°C CHSPV Reg D3 = 1	0.255	0.27	0.285	
I_{TSENSE}	Battery Temperature Sense Current		7.75	8.00	8.25	μA

- (1) All voltages are with respect to the potential at the GND pin.
- (2) Junction-to-ambient thermal resistance is highly application and board-layout dependent. In applications where high maximum power dissipation exists, special care must be paid to thermal dissipation issues in board design.
- (3) Min and Max limits are specified by design, test, or statistical analysis. Typical numbers represent the most likely norm.
- (4) Low ESR Surface-Mount Ceramic Capacitors (MLCCs) are used in setting electrical characteristics.
- (5) Typical values and limits appearing in normal type for $T_J = 25^\circ C$. Limits appearing in **boldface type** apply over the entire junction temperature range for operation, $-40^\circ C$ to $+125^\circ C$.

LI-ION BATTERY CHARGER ELECTRICAL CHARACTERISTICS (continued)

Unless otherwise noted, VDD = 5.0V, VBATT = 3.6V, CBATT = 4.7 μ F, CCHG_DET = 10 μ F, RIREF = 121 k Ω . Typical values and limits appearing in normal type apply for T_J = 25°C. Limits appearing in **boldface type** apply over the entire junction temperature range for operation, T_J = 0°C to +125°C. ⁽¹⁾⁽²⁾⁽³⁾⁽⁴⁾⁽⁵⁾

Symbol	Parameter	Conditions	Min	Typ	Max	Units
T _{REG}	Regulated Charger Junction Temperature		105	115	125	°C

DETECTION AND TIMING

Symbol	Parameter	Conditions	Min	Typ	Max	Units
I _{EOC}	End-of-Charge Current	I _{PROG} = 500 mA, 10% EOC Setting	40	50	60	mA
		I _{PROG} = 500 mA 5% EOC Setting	20	25	30	mA
V _{RESTARTI}	Battery Restart Charging Voltage	V _{TERM} = 4.1V V _{TERM} = 4.2V V _{TERM} = 4.38V	3.82 3.94 4.14	3.9V 4.0V 4.2 V	3.94 4.06 4.26	V
T _{CHG_IN}	Deglitch Adapter Insertion		28	32	36	ms
T _{USB}	Deglitch USB Power Insertion		28	32	36	ms
T _{PQ_FULL}	Deglitch Time for Pre-qualification to Full-rate Charge Transition		8	10	12	ms
T _{FULL_PQ}	Deglitch Time for Full-rate to Pre-qualification Transition		8	10	12	ms
T _{BATLOWF}	Deglitch Time for V _{BATT} Falling below V _{BATLOW} Threshold		4	5	6	ms
T _{BATLOWR}	Deglitch Time for V _{BATT} Rising above V _{BATLOW} Threshold		4	5	6	ms
T _{BATTEMP}	Deglitch Time for Recovery from Battery Temperature Fault		8	10	12	ms
T _{ONOFF_F}	Deglitching on Falling Edge of ONOFF Pin		28	32	36	ms
T _{ONOFF_R}	Deglitching on Rising Edge of ONOFF Pin		28	32	36	ms
T _{RESTART}	Deglitching on Falling V _{BATT} Crossing V _{RESTART}		8	10	12	ms
T _{CCCV}	Deglitching of CC->CV Charging Transition		8	10	12	ms
T _{CVEOC}	Deglitching of CV->EOC (End of Charge)		8	10	12	ms
T _{POWERACK}	Deglitching of POWERACK Pin		4	5	6	ms
T _{TSHD}	Deglitching of Thermal Shutdown			2		ms
T _{TOPOFF}	Topoff Timer		17	21	25	min
T _{10HR}	10 Hour Safety Timer		9	10	11	hours
T _{1HR}	1 Hour Prequal Safety Timer		0.9	1	1.1	hour

OUTPUTS ELECTRICAL CHARACTERISTICS: CHG, STAT

Unless otherwise noted, $V_{DD} = 5V$, $V_{BATT} = 3.6V$. $C_{BATT} = 4.7 \mu F$, $C_{CHG_DET} = 10 \mu F$. Typical values and limits appearing in normal type apply for $T_J = 25^\circ C$. Limits appearing in **boldface type** apply over the entire junction temperature range for operation, $T_J = 0^\circ C$ to $+125^\circ C$. ⁽¹⁾⁽²⁾⁽³⁾⁽⁴⁾⁽⁵⁾

Symbol	Parameter	Conditions	Min	Typ	Max	Units
I_{LED}	Output High Level	$V_{LED} = 2.0V$ CHSPV Register (02)h bit 5 = 1	4	5	6	mA
I_{LED}	Output High Level	$V_{LED} = 2.0V$ CHSPV Register (02)h bit 5 = 0	8	10	12	mA
$I_{LEAKAGE}$	Leakage Current	$V_{LED} = 1.5V$, LED off		0.1	5	μA
LED _{FREQ}	Blinking Frequency		0.8	1	1.2	Hz

- (1) All voltages are with respect to the potential at the GND pin.
- (2) Junction-to-ambient thermal resistance is highly application and board-layout dependent. In applications where high maximum power dissipation exists, special care must be paid to thermal dissipation issues in board design.
- (3) Min and Max limits are specified by design, test, or statistical analysis. Typical numbers represent the most likely norm.
- (4) Low ESR Surface-Mount Ceramic Capacitors (MLCCs) are used in setting electrical characteristics.
- (5) Typical values and limits appearing in normal type for $T_J = 25^\circ C$. Limits appearing in **boldfacetype** apply over the entire junction temperature range for operation, $-40^\circ C$ to $+125^\circ C$.

OUTPUTS ELECTRICAL CHARACTERISTICS: NRST, IRQB, ONSTAT

Unless otherwise noted, $V_{DD} = 5V$, $V_{BATT} = 3.6V$. $C_{BATT} = 4.7 \mu F$, $C_{CHG_DET} = 10 \mu F$. Typical values and limits appearing in normal type apply for $T_J = 25^\circ C$. Limits appearing in **boldface type** apply over the entire junction temperature range for operation, $T_J = 0^\circ C$ to $+125^\circ C$. ⁽¹⁾⁽²⁾⁽³⁾⁽⁴⁾⁽⁵⁾

Symbol	Parameter	Conditions	Min	Typ	Max	Units
V_{OL}	Output Low Level	$I_{OL} = 4 \text{ mA}$			0.4	V
$I_{LEAKAGE}$	Leakage Current	$V_{DD} = 2.5V$, Output Logic High	-1		1	μA

- (1) All voltages are with respect to the potential at the GND pin.
- (2) Junction-to-ambient thermal resistance is highly application and board-layout dependent. In applications where high maximum power dissipation exists, special care must be paid to thermal dissipation issues in board design.
- (3) Min and Max limits are specified by design, test, or statistical analysis. Typical numbers represent the most likely norm.
- (4) Low ESR Surface-Mount Ceramic Capacitors (MLCCs) are used in setting electrical characteristics.
- (5) Typical values and limits appearing in normal type for $T_J = 25^\circ C$. Limits appearing in **boldfacetype** apply over the entire junction temperature range for operation, $-40^\circ C$ to $+125^\circ C$.

INPUTS ELECTRICAL CHARACTERISTICS: USBSUSP, USBISEL

Unless otherwise noted, $V_{USB} = 5V$, $V_{BATT} = 3.6V$. $C_{BATT} = 4.7 \mu F$, $C_{CHG_DET} = 10 \mu F$. Typical values and limits appearing in normal type apply for $T_J = 25^\circ C$. Limits appearing in **boldface type** apply over the entire junction temperature range for operation, $T_J = 0^\circ C$ to $+125^\circ C$. ⁽¹⁾⁽²⁾⁽³⁾⁽⁴⁾⁽⁵⁾⁽⁶⁾

Symbol	Parameter	Conditions	Min	Typ	Max	Units
V_{IL}	Input Low Level				$0.3 \cdot V_{USB}$	V
V_{IH}	Input High Level		$0.7 \cdot V_{USB}$			V
$I_{LEAKAGE}$	Input Leakage		-1		1	μA

- (1) All voltages are with respect to the potential at the GND pin.
- (2) Junction-to-ambient thermal resistance is highly application and board-layout dependent. In applications where high maximum power dissipation exists, special care must be paid to thermal dissipation issues in board design.
- (3) Min and Max limits are specified by design, test, or statistical analysis. Typical numbers represent the most likely norm.
- (4) Low ESR Surface-Mount Ceramic Capacitors (MLCCs) are used in setting electrical characteristics.
- (5) Typical values and limits appearing in normal type for $T_J = 25^\circ C$. Limits appearing in **boldfacetype** apply over the entire junction temperature range for operation, $-40^\circ C$ to $+125^\circ C$.
- (6) LDO2EN, BUCK1EN, and USBSUSP have weak internal pull downs while pins POWERACK, ONOFF do not have this.

INPUTS ELECTRICAL CHARACTERISTICS: POWERACK, ONOFF, LDO2EN, BUCK1EN

Unless otherwise noted, $V_{DD} = 5V$, $V_{BATT} = 3.6V$, $C_{BATT} = 4.7 \mu F$, $C_{CHG_IN} = 10 \mu F$. Typical values and limits appearing in normal type apply for $T_J = 25^\circ C$. Limits appearing in **boldface type** apply over the entire junction temperature range for operation, $T_J = 0^\circ C$ to $+125^\circ C$. ⁽¹⁾⁽²⁾⁽³⁾⁽⁴⁾⁽⁵⁾⁽⁶⁾

Symbol	Parameter	Conditions	Min	Typ	Max	Units
V_{IL}	Input Low Level				0.4	V
V_{IH}	Input High Level		1.4			V
$I_{LEAKAGE}$	Input Leakage		-1		1	μA

- (1) All voltages are with respect to the potential at the GND pin.
- (2) Junction-to-ambient thermal resistance is highly application and board-layout dependent. In applications where high maximum power dissipation exists, special care must be paid to thermal dissipation issues in board design.
- (3) Min and Max limits are specified by design, test, or statistical analysis. Typical numbers represent the most likely norm.
- (4) Low ESR Surface-Mount Ceramic Capacitors (MLCCs) are used in setting electrical characteristics.
- (5) Typical values and limits appearing in normal type for $T_J = 25^\circ C$. Limits appearing in **boldface type** apply over the entire junction temperature range for operation, $-40^\circ C$ to $+125^\circ C$.
- (6) LDO2EN, BUCK1EN, and USBUSP have weak internal pull downs while pins POWERACK, ONOFF do not have this.

LDO1: LOW DROPOUT LINEAR REGULATORS

Unless otherwise noted, $V_{IN1} = 3.6V$, $I_{MAX} = 150 mA$, $V_{OUT} = \text{Default Value}$, $C_{VDD} = 10 \mu F$, $C_{LDO1} = 1.0 \mu F$, $ESR = 5 m\Omega - 500 m\Omega$, $C_{VREFH} = 100 nF$. Typical values and limits appearing in normal type apply for $T_J = 25^\circ C$. Limits appearing in **boldface type** apply over the entire junction temperature range for operation, $0^\circ C$ to $+125^\circ C$.

Symbol	Parameter	Conditions	Min	Typ	Max	Units
VIN1	Operational Voltage Range		2.5		6.0	V
V_{OUT} Range	Output Voltage Programming Range	$T_A = 25^\circ C$ 1.2V–3.3V in 100 mV Steps	1.2		3.3	V
V_{OUT} Accuracy	Output Voltage Accuracy	$1 mA \leq I_{OUT} \leq I_{MAX}$, Over Full Line and Load Regulation. $V_{OUT} = \text{Default Value}$.	-3		3	%
ΔV_{OUT}	Line Regulation	$V_{IN} = (V_{OUT} + 500 mV)$ to 5.5V, Load Current = I_{MAX}		3		mV
	Load Regulation	$V_{IN} = 3.6V$, Load Current = 1 mA to I_{MAX}		10		mV
I_{SC}	Short Circuit Current Limit	$V_{OUT} = 0V$	600	750		mA
$V_{IN} - V_{OUT}$	Dropout Voltage	Load Current = I_{MAX}		60	150	mV
PSRR	Power Supply Ripple Rejection	$F = 10 kHz$, Load Current = I_{MAX}		30		dB
R_{SHUNT}	LDO Output Impedance	LDO Disabled, $V_{OUT} = \text{Default Value}$			200	Ω

LDO2: LOW DROPOUT LINEAR REGULATOR

Unless otherwise noted $V_{IN1} = 3.6V$, $I_{MAX} = 150 mA$, $V_{OUT} = \text{Default Value}$, $C_{VDD} = 10.0 \mu F$, $C_{LDO2} = 1.0 \mu F$, $ESR = 5 m\Omega - 500 m\Omega$, $C_{VREFH} = 100 nF$. Typical values and limits appearing in normal type apply for $T_J = 25^\circ C$. Limits appearing in **boldface type** apply over the entire junction temperature range for operation, $0^\circ C$ to $+125^\circ C$.

Symbol	Parameter	Conditions	Min	Typ	Max	Units
VIN2	Operational Voltage Range		2.5		6.0	V
V_{OUT} Range	Output Voltage Programming Range	$T_A = 25^\circ C$ 1.3V–3.3V in 100 mV Steps	1.3		3.3	V
V_{OUT} Accuracy	Output Voltage Accuracy (Default V_{OUT})	$1 mA \leq I_{OUT} \leq I_{MAX}$, Over Full Line and Load Regulation.	-3		3	%
ΔV_{OUT}	Line Regulation	$V_{IN} = (V_{OUT} + 500 mV)$ to 5.5V, Load Current = I_{MAX}		3		mV
	Load Regulation	$V_{IN} = 3.6V$, Load Current = 1 mA to I_{MAX}		10		mV
I_{SC}	Short Circuit Current Limit	$V_{OUT} = 0V$	600	750		mA

LDO2: LOW DROPOUT LINEAR REGULATOR (continued)

Unless otherwise noted $V_{IN1} = 3.6V$, $I_{MAX} = 150\text{ mA}$, $V_{OUT} = \text{Default Value}$, $C_{VDD} = 10.0\ \mu\text{F}$, $C_{LDO2} = 1.0\ \mu\text{F}$, $ESR = 5\ \text{m}\Omega\text{--}500\ \text{m}\Omega$, $C_{VREFH} = 100\ \text{nF}$. Typical values and limits appearing in normal type apply for $T_J = 25^\circ\text{C}$. Limits appearing in **boldface type** apply over the entire junction temperature range for operation, 0°C to $+125^\circ\text{C}$.

Symbol	Parameter	Conditions	Min	Typ	Max	Units
$V_{IN} - V_{OUT}$	Dropout Voltage	Load Current = I_{MAX}		60	150	mV
PSRR	Power Supply Ripple Rejection	F = 1 kHz, Load Current = I_{MAX}		50		dB
		F = 10 kHz, Load Current = I_{MAX}		35		
e_N	Analog Supply Output Noise Voltage	10 Hz < F < 100 kHz		50		μVrms
R_{SHUNT}	LDO Output Impedance	LDO Disabled, $V_{OUT} = \text{Default Value}$			200	Ω

BUCK1 CONVERTER ELECTRICAL CHARACTERISTICS

Unless otherwise noted, $V_{IN2} = 3.6\ \text{V}$, $V_{OUT} = \text{default value}$, $C_{VIN2} = 10\ \mu\text{F}$, $C_{SW1} = 10\ \mu\text{F}$, $L_{SW1} = 2.2\ \mu\text{H}$ Typical values and limits appearing in normal type apply for $T_J = 25^\circ\text{C}$. Limits appearing in **boldface type** apply over the entire junction temperature range for operation, 0°C to $+125^\circ\text{C}$. Modulation mode is PWM mode with automatic switch to PFM at light loads.

Symbol	Parameter	Conditions	Min	Typ	Max	Units
V_{IN2}	Input Voltage		2.7		6.0	V
V_{OUT} Range	Output Voltage Programming Range	0.80V–2.00V in 50 mV Steps	0.8		2.0	V
ΔV_{OUT}	Static Output Voltage Tolerance	$I_{OUT} = 200\ \text{mA}$, Including Line and Load Regulation	-3		3	%
	Line Regulation	$I_{OUT} = 10\ \text{mA}$ $V_{IN2} = 2.5V - V_{DD}$		0.2		%/V
	Load Regulation	$100\ \text{mA} < I_{OUT} < 300\ \text{mA}$		0.002		%/mA
I_{OUT}	Continuous Output Current		600			mA
	Peak Output Current Limit		850	1000	1150	mA
I_{PFM}	Max I_{LOAD} , PFM Mode			75		mA
I_Q	Quiescent Current	$I_{OUT} = 0\ \text{mA}$		30	90	μA
		Buck1 Disabled			1	
F_{OSC}	Internal Oscillator Frequency	PWM Mode		2		MHz
η	Peak Efficiency			90		%
T_{ON}	Turn-on Time	To 95% Level ⁽¹⁾			1	ms

(1) Specified by design. Not production tested.

BUCK2 CONVERTER ELECTRICAL CHARACTERISTICS

Unless otherwise noted, $V_{IN3} = 3.6V$, $V_{OUT} = \text{default value}$, $C_{VIN3} = 10\ \mu\text{F}$, $C_{SW1} = 10\ \mu\text{F}$, $L_{SW2} = 2.2\ \mu\text{H}$ Typical values and limits appearing in normal type apply for $T_J = 25^\circ\text{C}$. Limits appearing in **boldface type** apply over the entire junction temperature range for operation, 0°C to $+125^\circ\text{C}$. Modulation mode is PWM mode with automatic switch to PFM at light loads.

Symbol	Parameter	Conditions	Min	Typ	Max	Units
V_{IN3}	Input Voltage		2.7		6.0	V
V_{OUT} Range	Output Voltage Programming Range	1.80V–3.30V in 100 mV Steps	1.8		3.3	V
ΔV_{OUT}	Static Output Voltage Tolerance	$I_{OUT} = 200\ \text{mA}$, Including Line and Load Regulation	-3		3	%
	Line Regulation	$I_{OUT} = 10\ \text{mA}$ $V_{IN3} = 2.5V - V_{DD}$		0.2		%/V
	Load Regulation	$100\ \text{mA} < I_{OUT} < 300\ \text{mA}$		0.002		%/mA

BUCK2 CONVERTER ELECTRICAL CHARACTERISTICS (continued)

Unless otherwise noted, $V_{IN3} = 3.6V$, $V_{OUT} =$ default value, $C_{VIN3} = 10 \mu F$, $C_{SW1} = 10 \mu F$, $L_{SW2} = 2.2 \mu H$ Typical values and limits appearing in normal type apply for $T_J = 25^\circ C$. Limits appearing in **boldface type** apply over the entire junction temperature range for operation, $0^\circ C$ to $+125^\circ C$. Modulation mode is PWM mode with automatic switch to PFM at light loads.

Symbol	Parameter	Conditions	Min	Typ	Max	Units
I_{OUT}	Continuous Output Current		600			mA
	Peak Output Current Limit		850	1000	1150	mA
I_{PFM}	Max I_{LOAD} , PFM Mode			75		mA
I_Q	Quiescent Current	$I_{OUT} = 0$ mA		30	90	μA
		Buck2 Disabled			1	
F_{OSC}	Internal Oscillator Frequency	PWM Mode		2		MHz
η	Peak Efficiency			90		%
T_{ON}	Turn-on Time	To 95% Level ⁽¹⁾			1	ms

(1) Specified by design. Not production tested.

BUCK3 ELECTRICAL CHARACTERISTICS

Unless otherwise noted, $V_{IN4} = 3.6V$, $C_{VIN4} = 10 \mu F$, $C_{BB} = 22 \mu F$, $L_{BB} = 2.2 \mu H$ Typical values and limits appearing in normal type apply for $T_J = 25^\circ C$. Limits appearing in **boldface type** apply over the entire junction temperature range for operation, $0^\circ C$ to $+125^\circ C$. Modulation mode is PWM mode with automatic switch to PFM at light loads.

Symbol	Parameter	Conditions	Min	Typ	Max	Units
V_{IN4}	Input Voltage	$I_{OUTMAX} = 500$ mA	2.7		5.7	V
V_{OUT} Range	Output Voltage Programming Range	1.80V – 3.30V in 50 mV Steps	1.8		3.3	V
ΔV_{OUT}	Static Output Voltage Tolerance	$I_{OUT} = 0$ mA–500 mA, Including Line and Load Regulation	-4		4	%
	Line Regulation	$I_{OUT} = 10$ mA		0.2		%/V
	Load Regulation	100 mA < I_{OUT} < 500 mA		0.0016		%/mA
I_{OUT}	Continuous Output Current		500			mA
	Peak Inductor Current Limit	$V_{OUT} = 3.3V$ 1A Load at $V_{IN} = 2.7V$	900		1200	mA
I_{PFM}	Max I_{LOAD} , PFM Mode			75		mA
I_Q	Quiescent Current	$I_{OUT} = 0$ mA PFM No Switching		80		μA
		Buck3 Disabled			1	
F_{OSC}	Internal Oscillator Frequency	PWM Mode		2		MHz
η	Peak Efficiency			93		%
T_{ON}	Turn-on Time	To 95% Level ⁽¹⁾			1	ms

(1) Specified by design. Not production tested.

ADC ELECTRICAL CHARACTERISTICS

External components:

Symbol	Parameter	Conditions	Min	Typ	Max	Units
V _{REF}	Reference Voltage	T = 25°C	1.220	1.225	1.230	V
		T = 0°C to +125°C	1.200	1.225	1.230	V
INL	Core ADC Integral Non-linearity	V _{REF} = 1.225 ⁽¹⁾	-1		1	LSB
DNL	Core ADC Differential Non-linearity	V _{REF} = 1.225 ⁽¹⁾	-0.5		0.5	LSB
V _{GP_IN}	General Purpose ADC Input Voltage Range		V _{REF}		2·V _{REF}	V
VBATT,	Battery Max Voltage Scalar Output	VBATT = 3.5V	2.435	2.45	2.465	V
RANGE 0	Battery Min Voltage Scalar Output	VBATT = 2.6V	1.217	1.225	1.232	V
V _{BATT,}	Battery Max Voltage Scalar Output	VBATT = 4.4V	2.435	2.45	2.465	V
RANGE 1	Battery Min Voltage Scalar Output	V _{REF} = 2.6V	1.217	1.225	1.232	V
V _{ISENSE}	ISENSE Max Voltage Scalar Output	V _{ISENSE} = 0.6463V (I _{CHG} = 0.605A, R _{SENSE} = 4.64 kΩ)	2.373	2.45	2.519	V
RANGE 0	ISENSE Min Voltage Scalar Output	V _{ISENSE} = 0V (I _{CHG} = 0A, R _{SENSE} = 4.64 kΩ)	1.186	1.225	1.260	V
V _{ISENSE}	ISENSE Max Voltage Scalar Output	V _{ISENSE} = 1.175V (I _{CHG} = 1.1A, R _{SENSE} = 4.64 kΩ)	2.373	2.45	2.519	V
RANGE 1	ISENSE Min Voltage Scalar Output	V _{ISENSE} = 0V (I _{CHG} = 0A, R _{SENSE} = 4.64 kΩ)	1.186	1.225	1.260	V
ADC1 & ADC2 _{MIN}	ADC1 & ADC2 Min Voltage Scalar Output	V _{REFH} = 1.225	1.218	1.225	1.230	V
ADC1 & ADC2 _{MAX}	ADC1 & ADC2 Max Voltage Scalar Output	V _{REFH} = 1.225	2.436	2.45	2.46	V
t _{CONV}	Conversion Time	⁽¹⁾			5	ms
t _{WARM}	Warm-up Time			2		ms

(1) Specified by design. Not production tested.

TYPICAL CHARACTERISTICS — BATTERY CHARGER

$T_A = 25^\circ\text{C}$ unless otherwise noted

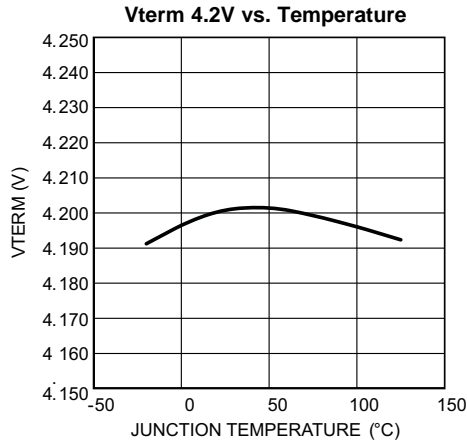

Figure 2.

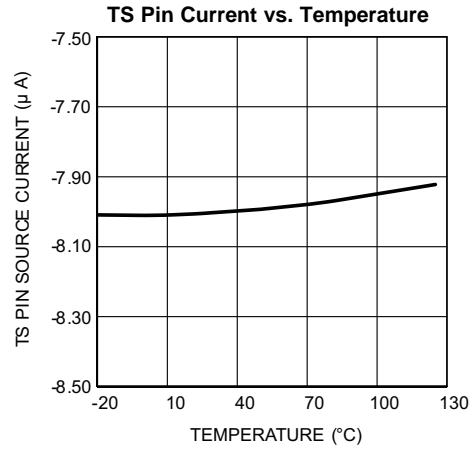

Figure 3.

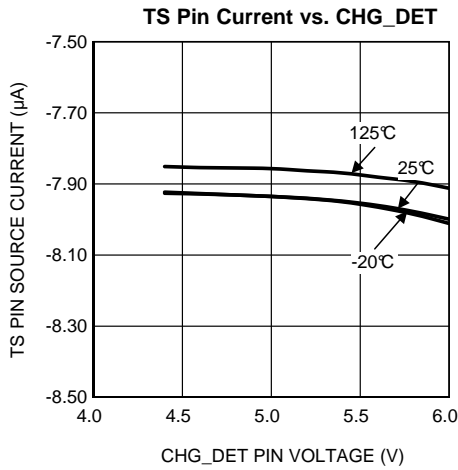

Figure 4.

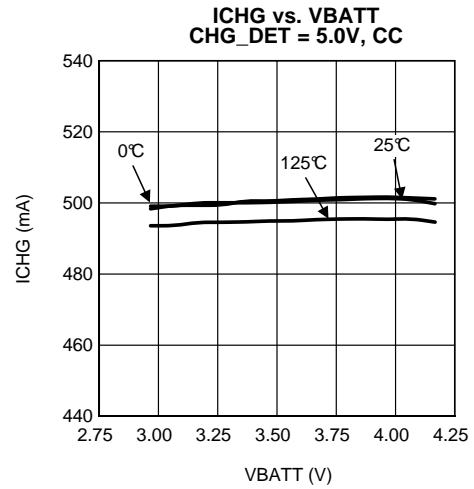

Figure 5.

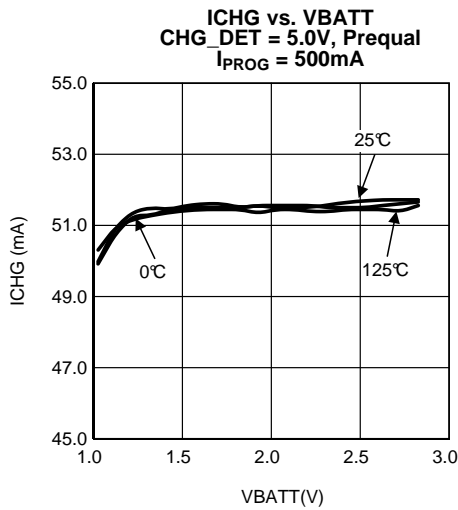

Figure 6.

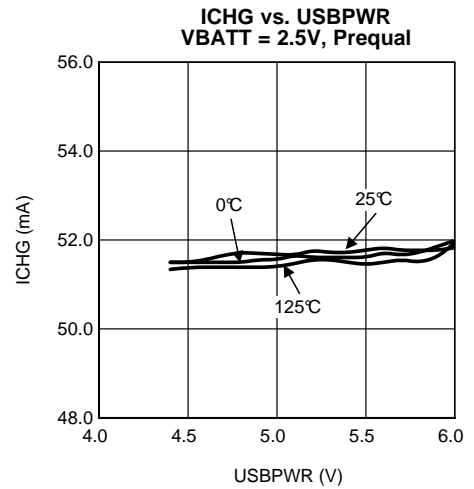

Figure 7.

TYPICAL CHARACTERISTICS — BATTERY CHARGER (continued)

T_A = 25°C unless otherwise noted

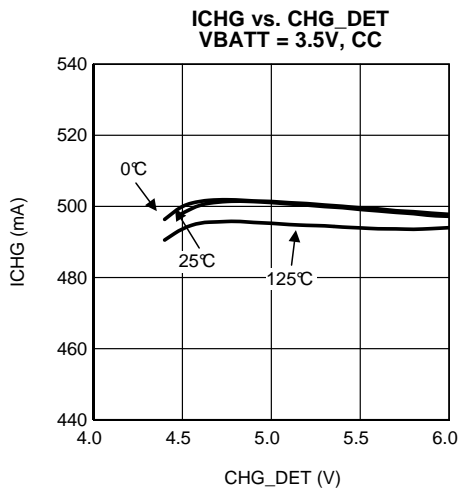

Figure 8.

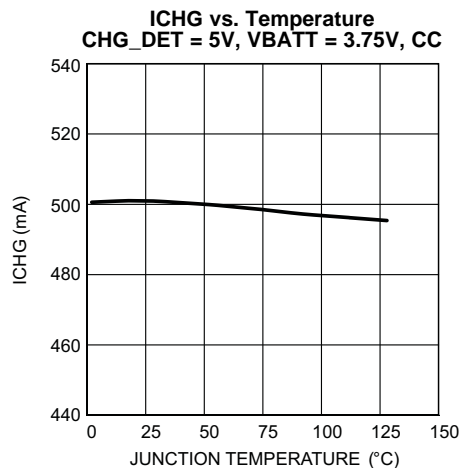

Figure 9.

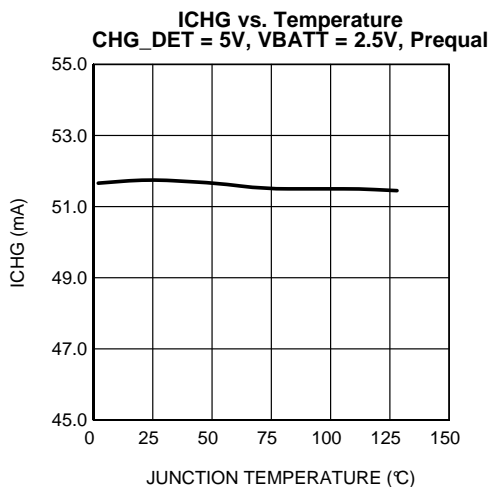

Figure 10.

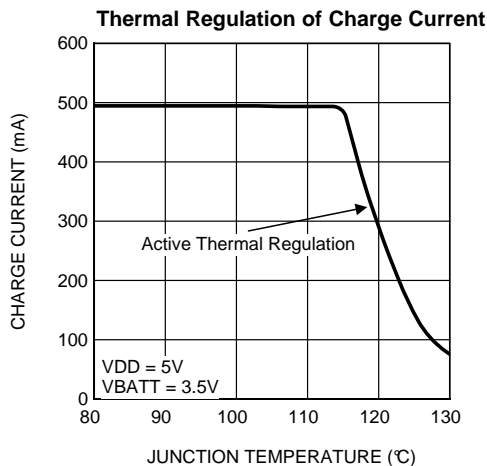

Figure 11.

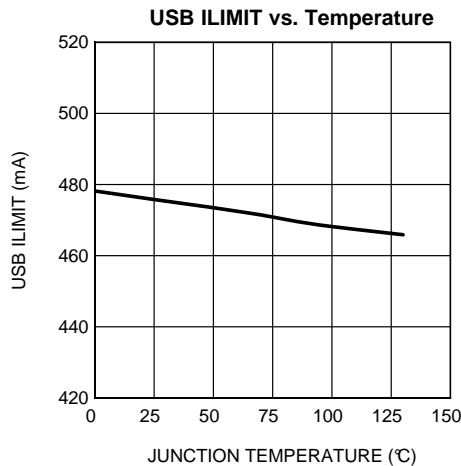

Figure 12.

TYPICAL CHARACTERISTICS — BATTERY CHARGER (continued)

T_A = 25°C unless otherwise noted

Wall Adapter Insertion with USBPWR present
CH1 = Charge Current (mA); CH3 = CHG_DET (V);
CH4 = USBPWR (V)

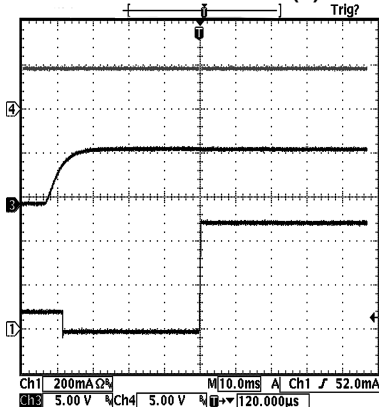

Figure 13.

Wall Adapter Removal with USBPWR present
CH1 = Charge Current (mA); CH3 = CHG_DET (V);
CH4 = USBPWR (V)

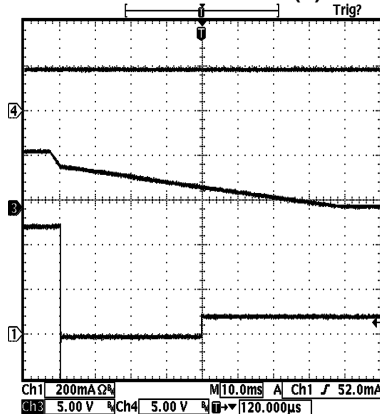

Figure 14.

TYPICAL PERFORMANCE CHARACTERISTICS — LDO

$T_A = 25^\circ\text{C}$ unless otherwise noted

Output Voltage Change vs Temperature (LDO1)
 $V_{in} = 4.3\text{V}$, $V_{out} = 3.3\text{V}$, 100 mA load

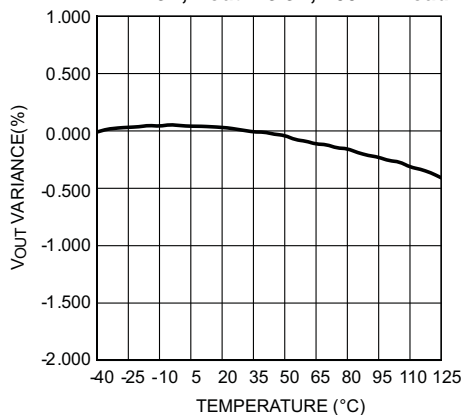

Figure 15.

Output Voltage Change vs Temperature (LDO2)
 $V_{in} = 4.3\text{V}$, $V_{out} = 1.8\text{V}$, 100 mA load

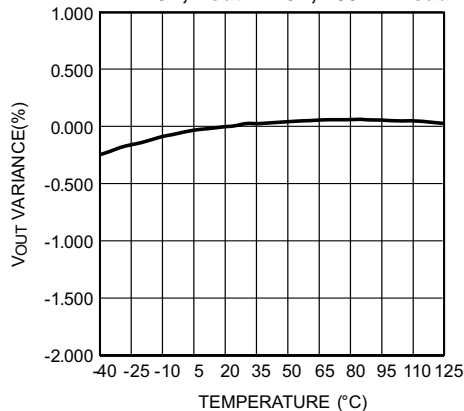

Figure 16.

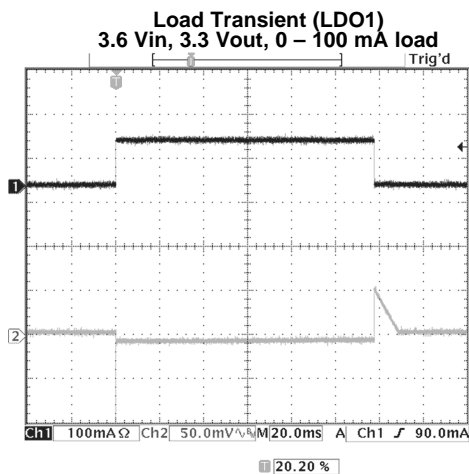

Figure 17.

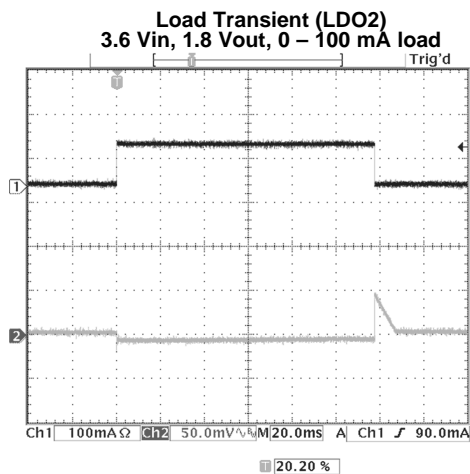

Figure 18.

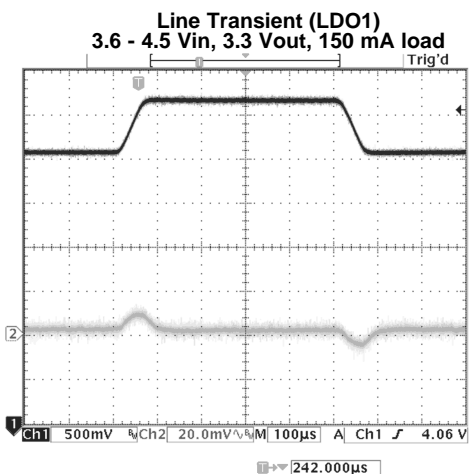

Figure 19.

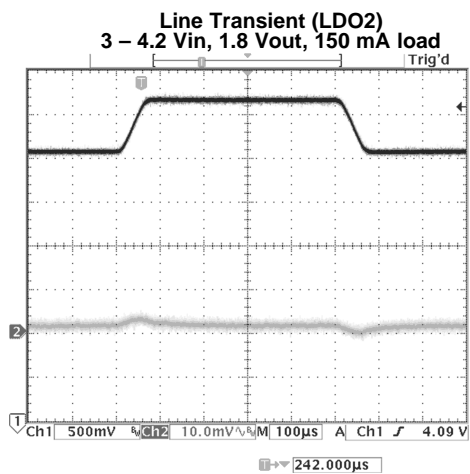

Figure 20.

TYPICAL PERFORMANCE CHARACTERISTICS — LDO (continued)

T_A = 25°C unless otherwise noted

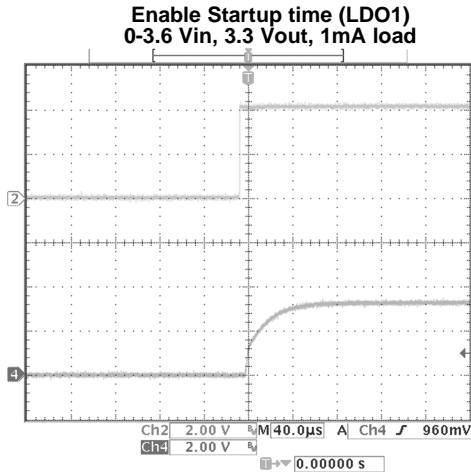

Figure 21.

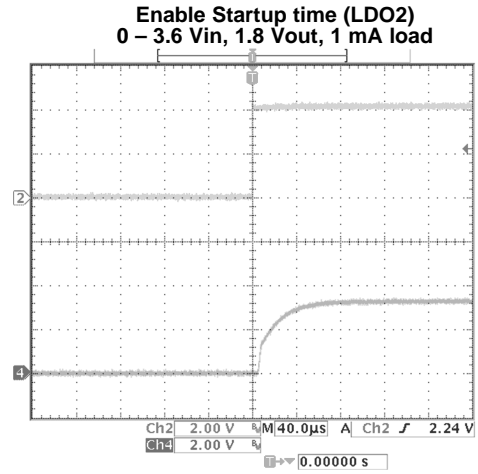

Figure 22.

TYPICAL PERFORMANCE CHARACTERISTICS - BUCK

T_A = 25°C unless otherwise noted

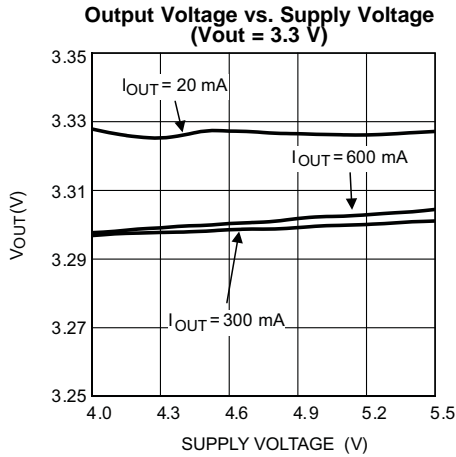

Figure 23.

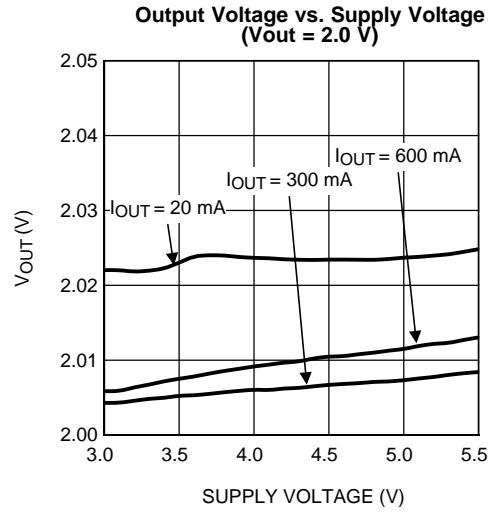

Figure 24.

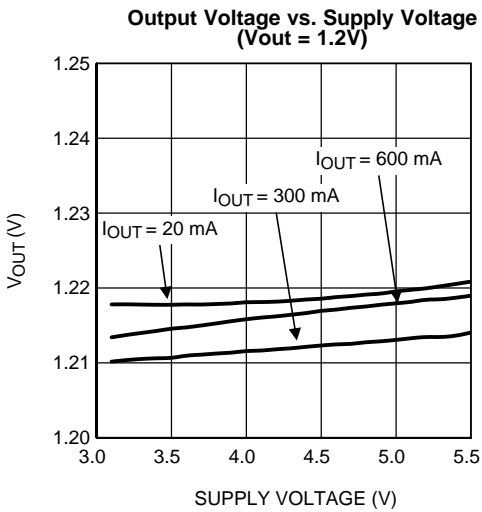

Figure 25.

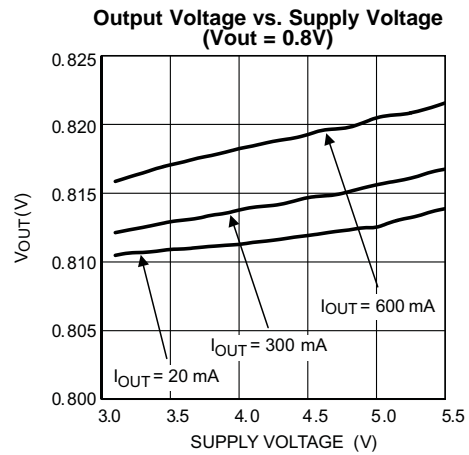

Figure 26.

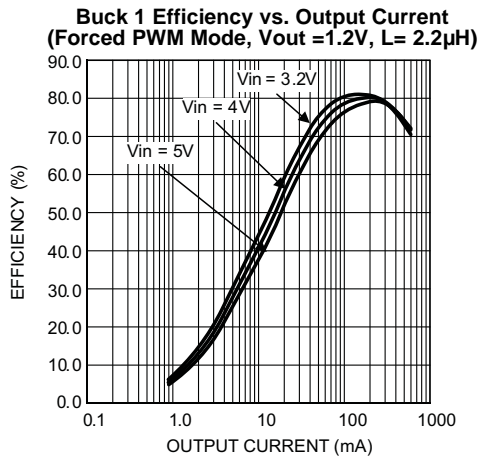

Figure 27.

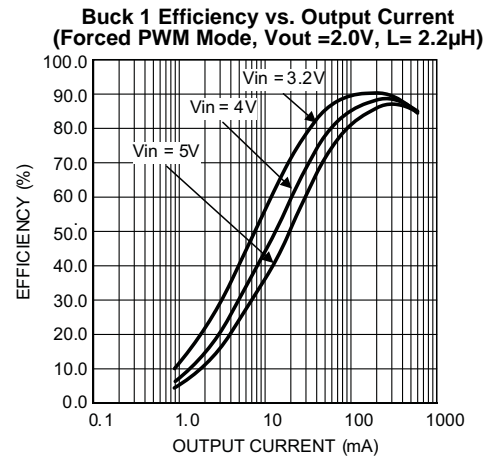

Figure 28.

TYPICAL PERFORMANCE CHARACTERISTICS - BUCK (continued)

T_A = 25°C unless otherwise noted

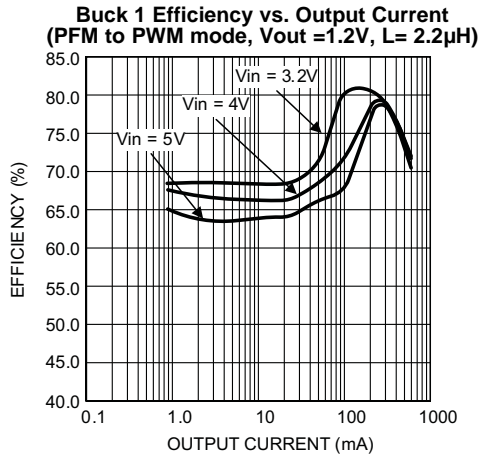

Figure 29.

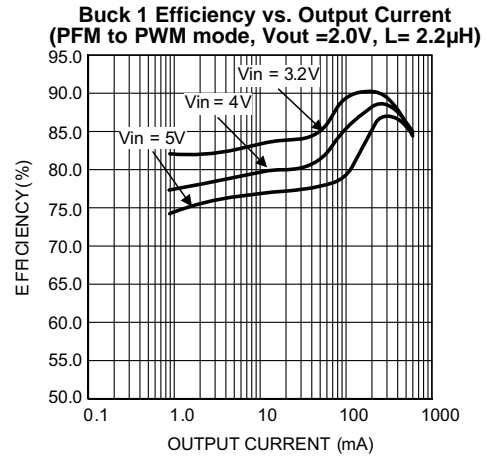

Figure 30.

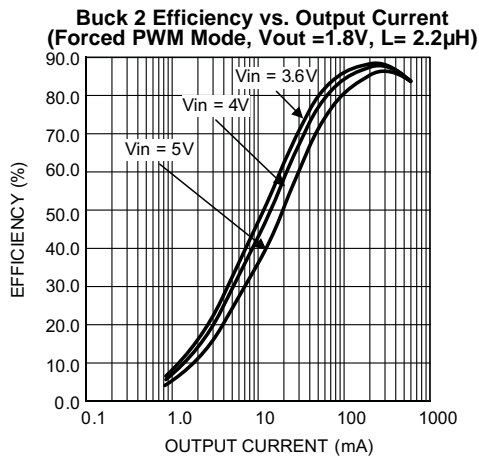

Figure 31.

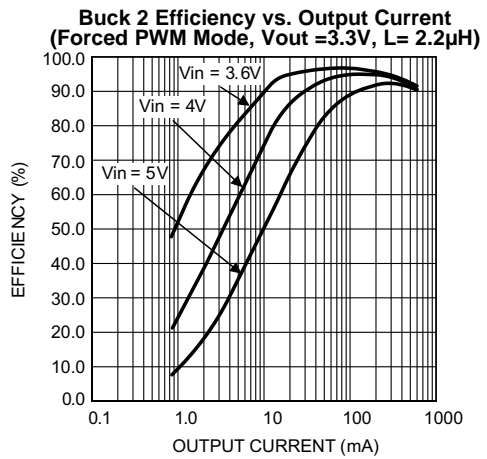

Figure 32.

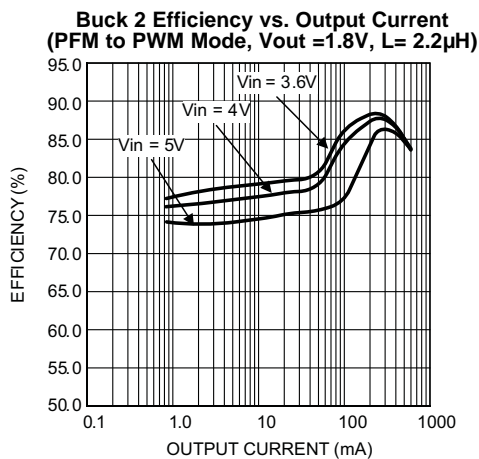

Figure 33.

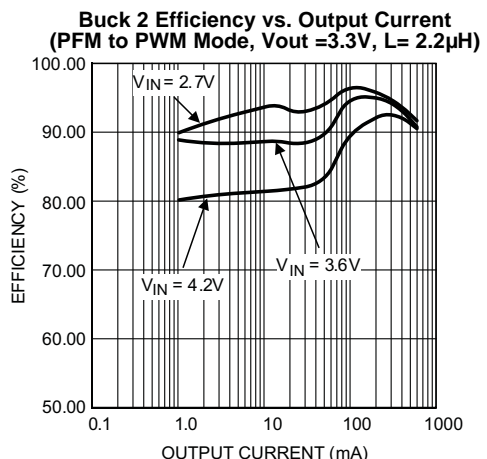

Figure 34.

TYPICAL PERFORMANCE CHARACTERISTICS - BUCK (continued)

T_A = 25°C unless otherwise noted

Buck 1 Load Transient Response
VIN = 4.2V, VOUT = 1.2V
ILOAD = 200-400mA (PWM Mode)

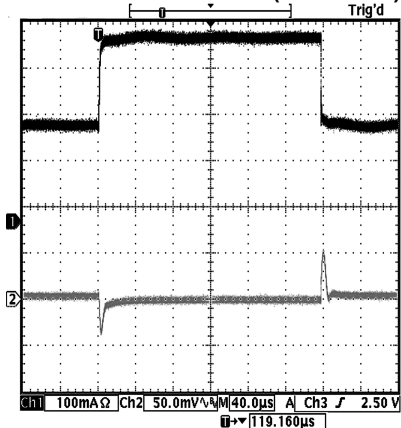

Figure 35.

Buck 1 Load Transient Response
VIN = 4.2V, VOUT = 1.2V
ILOAD = 50-150mA (PFM to PWM)

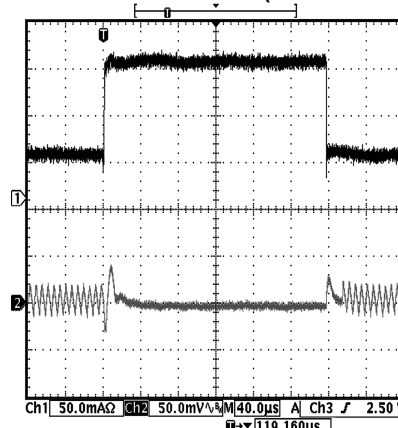

Figure 36.

Buck 2 Load Transient Response
VIN = 4.2V, VOUT = 3.3V
ILOAD = 200-400mA (PWM Mode)

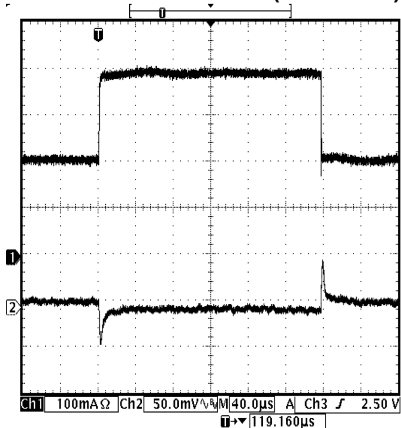

Figure 37.

Buck 2 Load Transient Response
VIN = 4.2V, VOUT = 3.3V
ILOAD = 50-150mA (PFM to PWM)

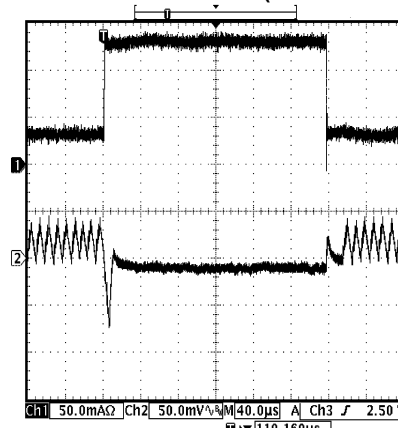

Figure 38.

Line Transient Response
Vin = 3 – 3.6 V, Vout = 1.2 V, 250 mA load

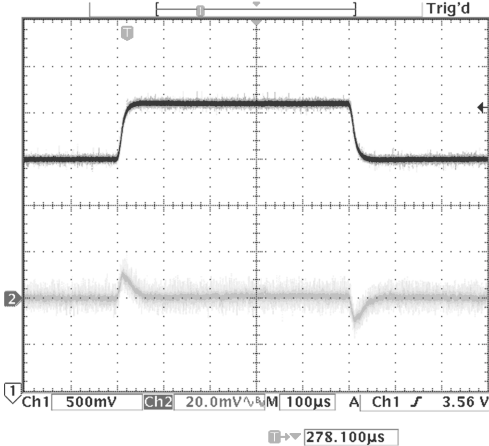

Figure 39.

Line Transient Response
Vin = 3.6 – 4.2 V, Vout = 3.3 V, 250 mA load

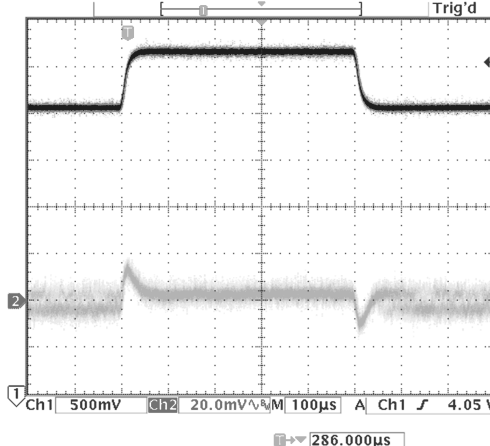

Figure 40.

TYPICAL PERFORMANCE CHARACTERISTICS - BUCK (continued)

T_A = 25°C unless otherwise noted

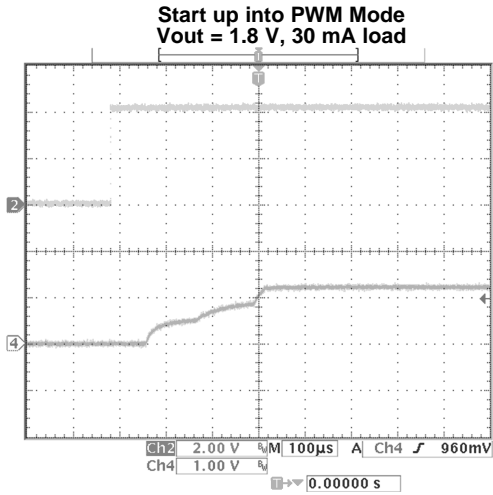

Figure 41.

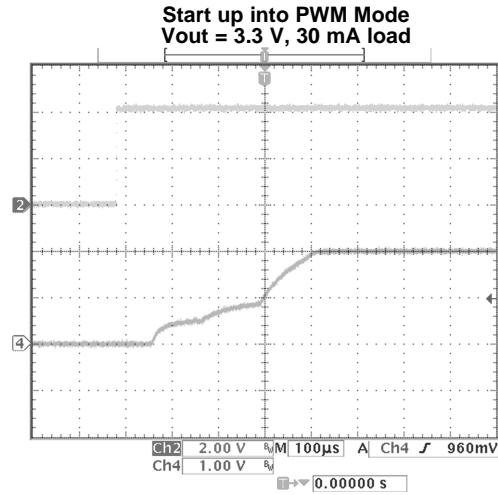

Figure 42.

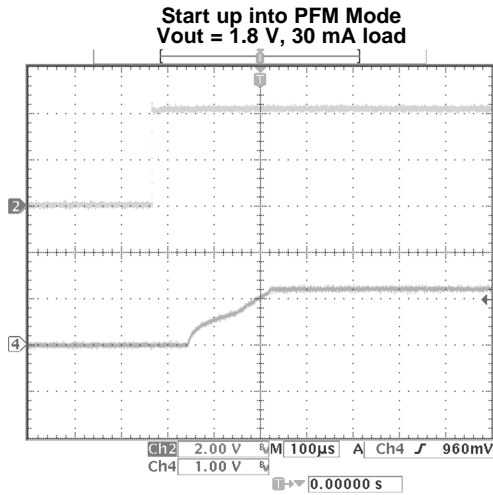

Figure 43.

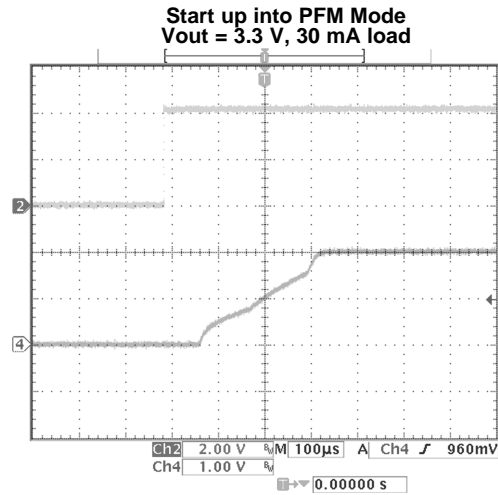

Figure 44.

TYPICAL PERFORMANCE CHARACTERISTICS - BUCK3

$T_A = 25^\circ\text{C}$ unless otherwise noted

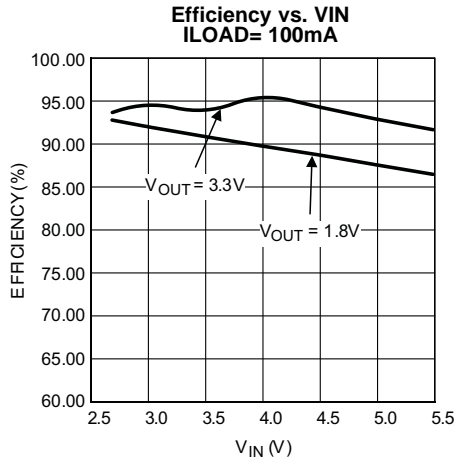

Figure 45.

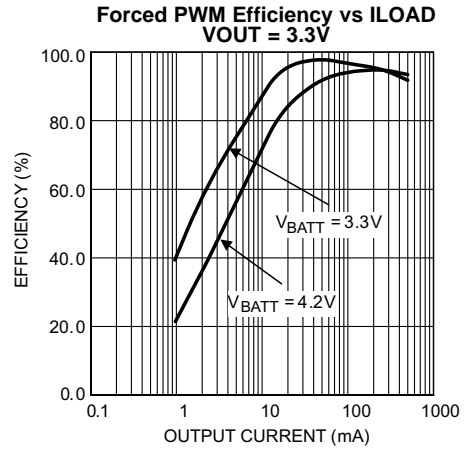

Figure 46.

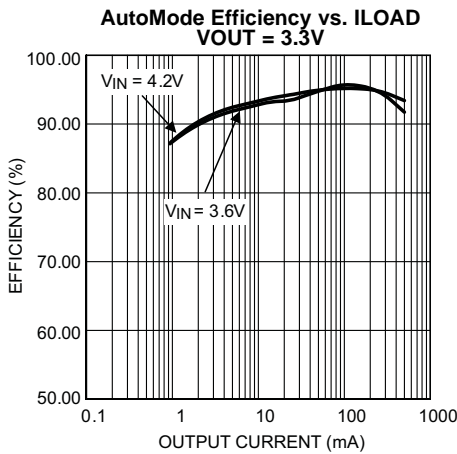

Figure 47.

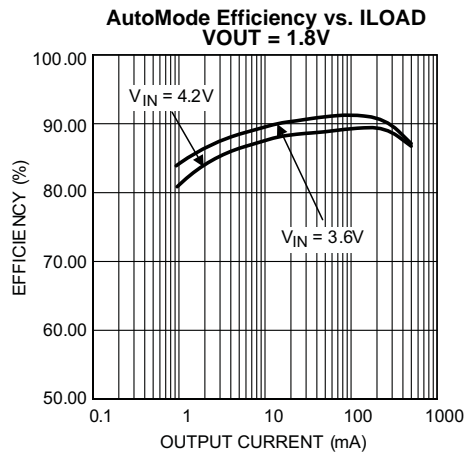

Figure 48.

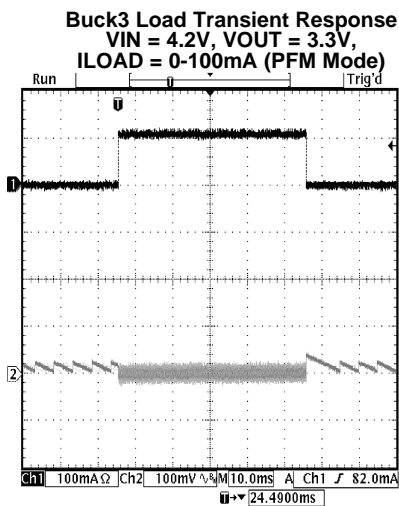

Figure 49.

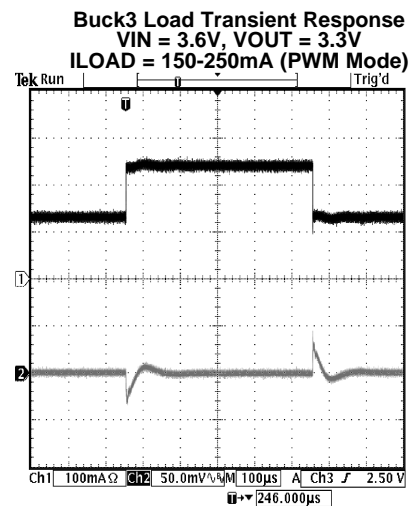

Figure 50.

TYPICAL PERFORMANCE CHARACTERISTICS - BUCK3 (continued)

T_A = 25°C unless otherwise noted

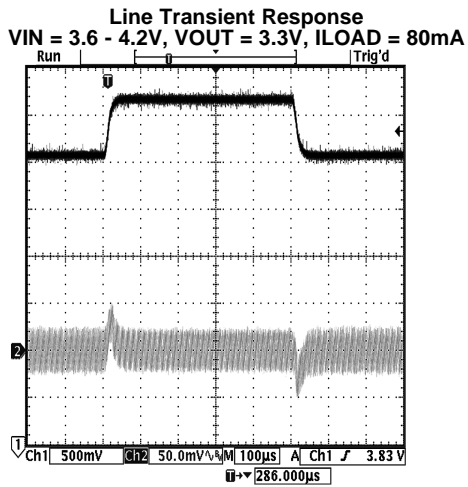

Figure 51.

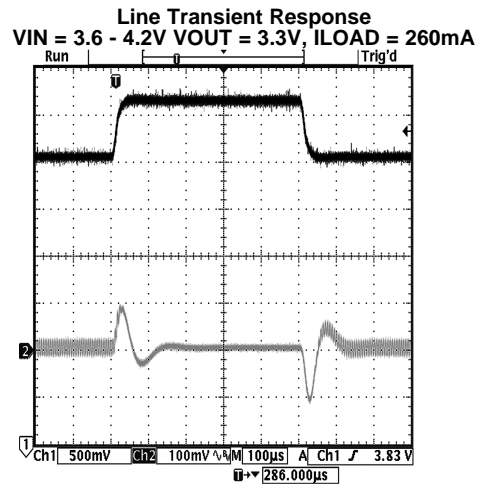

Figure 52.

FUNCTIONAL DESCRIPTION

Operating Modes

The LP3913 can be in 3 different operating modes as illustrated in [Figure 53](#):

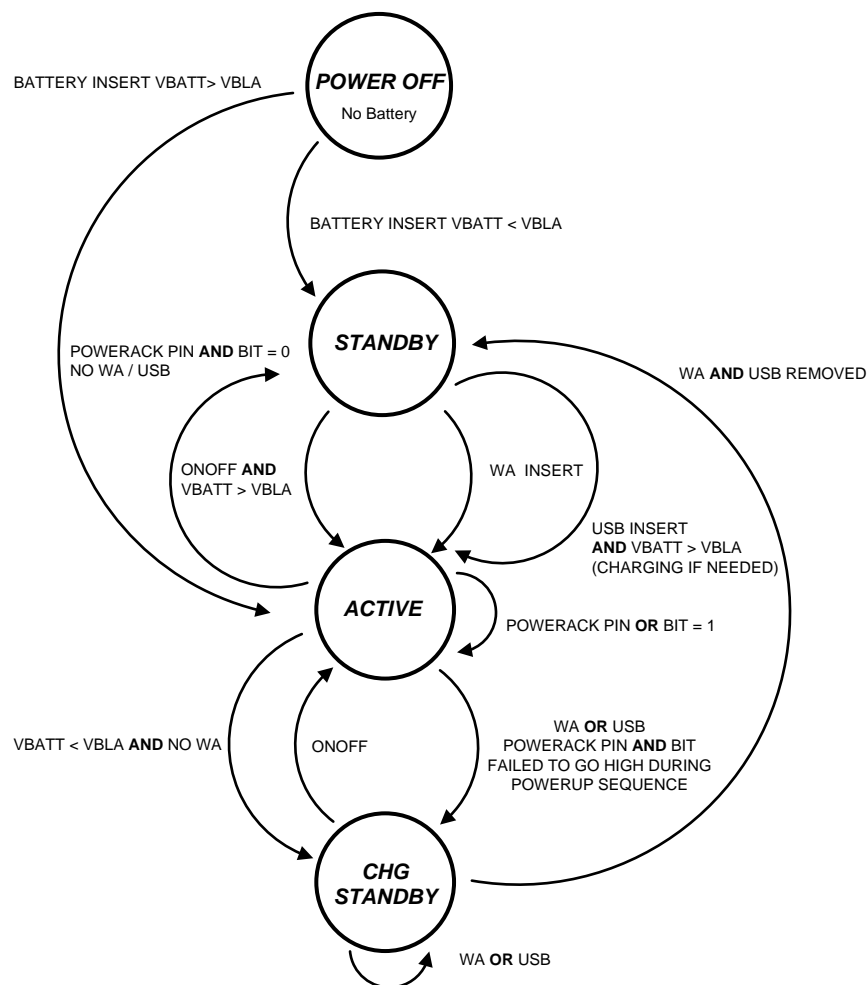

Figure 53. Operating Mode State Diagram

State Machine Definitions

V_{B_{LA}} Battery low alarm threshold

V_{B_{ATT}} Battery voltage

WA Wall Adapter

USB Universal Serial Bus Adapter

ONOFF On off pin event

POWERACK Acknowledgment from the Host Processor

Figure 54. Voltage Threshold Levels

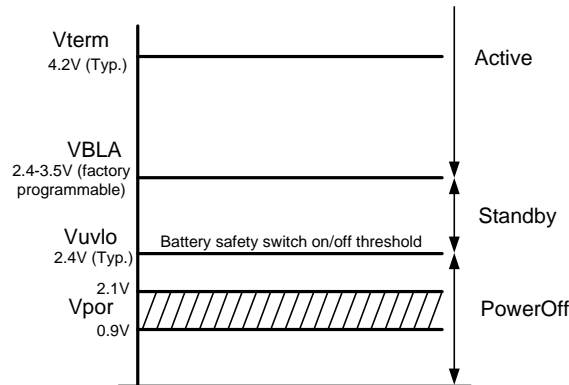

Table 2. Power State Table

	Power Off	Standby	Active	Charger Standby
LDO1,2	Off	Off	On	Off
BUCK1,2	Off	Off	On	Off
BUCK3	Off	Off	On	Off
CHARGER	Off	Off	On if Charger / USB Present	On if Charger / USB Present
A/D Converter	Off	Off	On	Off
NRST	Low	Low	High	Low
I ² C interface	Off	Off	On	On
Internal System Oscillator	Off	Off	On	On
Battery Monitor	Off	On	On	On
Current consumption	<1 μ A	10 μ A (typ)	See Electrical Characteristics	See Electrical Characteristics

Power-On-Reset

The LP3913 is equipped with an internal Power-On-Reset (“POR”) circuit that will reset the logic when $V_{DD} < V_{POR}$. This ensures that the logic is properly initialized when V_{DD} rises above the minimum operating voltage of the Logic and the internal oscillator that clocks the Sequential Logic in the Control section.

Thermal Shutdown and Thermal Alarm

An internal temperature sensor monitors the junction temperature of the LP3913 and forcibly invokes standby mode in the unusual case when the junction temperature of the silicon exceeds the normal operating level due to excessive loads on all power regulators and the Li-ion charger and/or due to an abnormally high ambient temperature. The thermal Shutdown threshold is 160°C.

The thermal shutdown is preceded by a Thermal alarm that generates an interrupt request if unmasked (see Interrupt Request generation). The temperature threshold for triggering the alarm is 115°C.

NRST Pin

The NRST pin is an open-drain output and is active low during Standby, Power Off and Charger Standby modes. The NRST timing is determined by a factory programmable counter.

Control Registers

The LP3913 contains 14 user programmable registers that configure the functionality of the individual modules inside the IC. Registers are programmed through an I²C interface and have default values that are invoked during an internal reset. Some of the default values can be tailored to the specific needs of the system designer (see [APPLICATIONS INFORMATION](#)).

Throughout this product specification, the register address is noted in hexadecimal notation immediately following the register name as illustrated below:

PON Register (00)h Power On Event Register

	D7–4	D3	D2	D1	D0
--	------	----	----	----	----

Battery Monitor

The battery voltage is monitored and will invoke the Power Off mode when the battery low threshold is breached for more than 5 ms (Typ.). The battery low threshold DEFAULT is factory programmed. The battery low threshold range is 2.5V–3.5V with steps of 50 mV. The Battery low threshold in the table below refers to a decreasing battery voltage. The threshold when the battery voltage is transitioning out of the V_{BATTLOW} is 50 mV (Typ.) higher than the values listed in the table below due to a built-in hysteresis of 50 mV (Typ.).

The battery low IRQ is triggered 200 mV above the battery low alarm threshold that powers down the IC. This gives the user time for a controlled shutdown.

BATTLOW Register (04)h Battery Low Alarm Register

	D7–5	D4–0		
Access	Read Only 0	rw		
Data	reserved	Battery Low Threshold Voltage (V)	Battery Low IRQ Threshold Voltage (V)	
		5'h14–1F	2.50	2.70
		5'h13	2.55	2.75
		5'h12	2.60	2.80
		5'h11	2.65	2.85
		5'h10	2.70	2.90
		5'h0F	2.75	2.95
		5'h0E	2.80	3.00
		5'h0D	2.85	3.05
		5'h0C	2.90	3.10
		5'h0B	2.95	3.15
		5'h0A	3.00	3.20
		5'h09	3.05	3.25
		5'h08	3.10	3.30
		5'h07	3.15	3.35
		5'h06	3.20	3.40
		5'h05	3.25	3.45
		5'h04	3.30	3.50
		5'h03	3.35	3.55
		5'h02	3.40	3.60
		5'h01	3.45	3.65
		5'h00	3.50	3.70
Reset	n/a	5'h0C	2.90	3.10

Power Off Mode

In Power Off mode the main battery, the battery charger supply, and the USB supply are below their minimum on levels. All internal circuits are disabled as the supply voltage is below the level to activate them. The LP3913 is in Power Off mode when the battery voltage is below the battery V_{UVLO} (2.4V typ) except when a valid external supply is detected.

Standby

When the LP3913 is in Standby Mode, the chip is waiting for a valid power-on event to transition to Active Mode. There are 3 valid wakeup signals. First is the ONOFF pin. Second is Wall Adapter Insertion. Third is the USB insertion. V_{BATT} must be greater than the battery V_{UVLO} in order to stay in Standby Mode, otherwise the chip transitions to Power Off Mode. Standby Mode is skipped when advancing from Power Off Mode when a battery is inserted that is above the battery low alarm threshold.

If the battery is below the battery low alarm threshold, Power Off Mode transitions to Standby Mode. However, hot insertion of the battery with the adapter connected is NOT permitted. In Standby Mode, the current consumption is reduced to I_Q (10 μ A TYP).

Active Mode

All LP3913 circuits are fully operational in Active mode.

Power On/Off Sequencing

Each DC/DC converter (Buck1, Buck2, Buck3, LDO1, LDO2) and the NRST pin of the LP3913 has its own delay after which it is enabled following a power-on event or disabled following a power-off event. Following the deglitching of the power-on event, the system bandgaps are enabled. Following this is a 5 ms delay that internal circuitry requires to cleanly power up. The programmable delays are measured from this time point. Following the deglitching of a power-down event (up to 5 ms if POWERACK pin is used), the power-down sequencer will start. Each delay ranges from 0 ms to 63 ms in steps of 1 ms and is factory programmed to the desired values submitted by the system designer. As illustrated below, the power-on/off sequencing is designed around a 6-bit up/down timer that is clocked at 1 kHz. A power-on or power-off event will trigger the timer, which counts up from 0 during a power-on sequence and counts down from 5'b11111 during a power-down cycle. The timer output is connected to 5 comparators with factory programmed timeout values that correspond to the on and off delays for each DC/DC converter and the NRST pin. Once the timer has incremented beyond the comparator timeout value during a power-on cycle, the output of the comparator enables the corresponding DC/DC converter or raises the NRST pin to a logic high level. Subsequently, once the timer has decremented below the comparator timeout value during a power-down cycle, the output of the comparator will disable the corresponding DC/DC converter or will activate the NRST pin to a logic low level.

Figure 55. Power up Sequence:

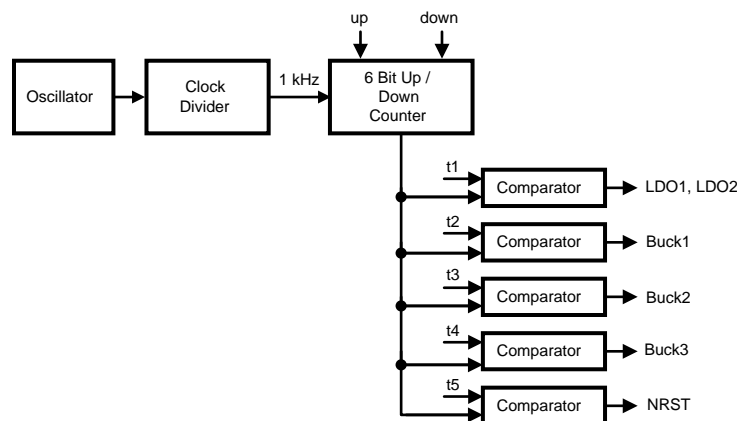

Power On Timing

Each timeout T1 thru to T5 are factory programmed from 0 ms to 63 ms. The following defaults are shown below.

Symbol	Description	Time	Units
T1	Programmable Delay for LDO1 and LDO2	5	ms
T2	Programmable Delay to Buck1	15	ms
T3	Programmable Delay for Buck2	20	ms
T4	Programmable Delay for Buck3	25	ms
T5	Programmable Delay for NRST	60	ms

Power Off Timing

The timing delays during a power off sequence are equal to 63 ms minus the timing delay during the power on sequence.

Symbol	Description	Time	Units
T1	Programmable delay for LDO1 and LDO2	58	ms
T2	Programmable delay to Buck1	48	ms
T3	Programmable delay for Buck2	43	ms
T4	Programmable delay for Buck3	38	ms
T5	Programmable delay for NRST	3	ms

Transitioning from Standby to Active Mode (Power Up) Battery Power Present Only

When only battery power is present and the battery voltage $V_{BATT} > V_{BATTLOW}$, the LP3913 is waiting for one of three valid wakeup signals. The first is the ONOFF pin. The second and third wakeups are the Wall Adapter and USBPWR. The ONOFF pin is factory programmable wakeup source. It can be a rising edge, a falling edge, a level high, or a level low event. Regardless of the mode, the signal requires a 32 ms deglitch time. A deglitched version of the ONOFF pin is output on the open-drain output pin ONSTAT. ONOFF is usually connected to a push button. Asserting the ONOFF pin starts the power on sequencer. This enables the DC/DC converters including the Buck1 DC/DC converter that supplies power to the system processor. The system processor then needs to set bit D4 (PACK bit) in the Power On Event Register through the I²C interface or apply a logic high to the POWERACK pin to keep the LP3913 in the Active mode. These serve as a Power Acknowledgment, confirming the power on request initiated by the ONOFF pin. If neither the PACK bit (D4) in the PON register or the POWERACK pin is set within 128 ms (max) of the start of the power-up sequencer, then the LP3913 will automatically turn off, as the system failed to acknowledge the power on request. Connecting the battery will be considered a Power on event. However hot insertion of the battery with the adapter connected is NOT permitted.

PON Register (00)h Power On Event Register

	D7–5	D4	D3	D2	D1	D0
Access	Read Only 0	rw	Read Only			
Data	Reserved	PACK	Battery Insert	PON by ONOFF	PON by CHG_IN	PON by USB Power
		0: Disable Power, go in standby, and wait for power on event.	0: default	0: default	0: default	0: default
		1: Acknowledge Power On request	1: Battery Insert caused by Battery Insertion	1: ONOFF caused Power On event	1: Power On caused by CHG_IN power detection	1: Power On caused by USB power detection
Reset	n/a	0	0	0	0	0

External Power and Battery Detection

When a Wall Adapter is detected, regardless of the battery voltage, the LP3913 moves to the Active Mode and the Power-up sequencer is started. Similar to the ONOFF pin, there is a 32 ms deglitch time to ensure a clean wall adapter detection and the system processor needs to set the PACK bit (D4) in the PON register or the POWERACK pin within 128 ms (max) of the start of the power-up sequencer.

When USB PWR is detected and the battery is above the low battery alarm threshold, the LP3913 moves to the Active Mode and the Power-up sequencer is started. Similar to the ONOFF pin, there is a 32 ms deglitch time to ensure a clean USB detection and the system processor needs to set the PACK bit (D4) in the PON register or the POWERACK pin within 128 ms (max) of the start of the power-up sequencer. If the battery is below the low battery alarm threshold, the system will remain powered down until the USBPWR charges the battery up to the battery low alarm threshold, at which point the power-up sequencer is started.

The four LSB bits of the PON register indicate which PON source was responsible for moving the LP3913 out of standby and into active mode:

- Battery insert
- ONOFF push button
- CHG_IN detect (connection of power adapter)
- USB power (plug-in of powered USB cable)

These bits are cleared upon powering off.

Figure 56. Power Up Sequence

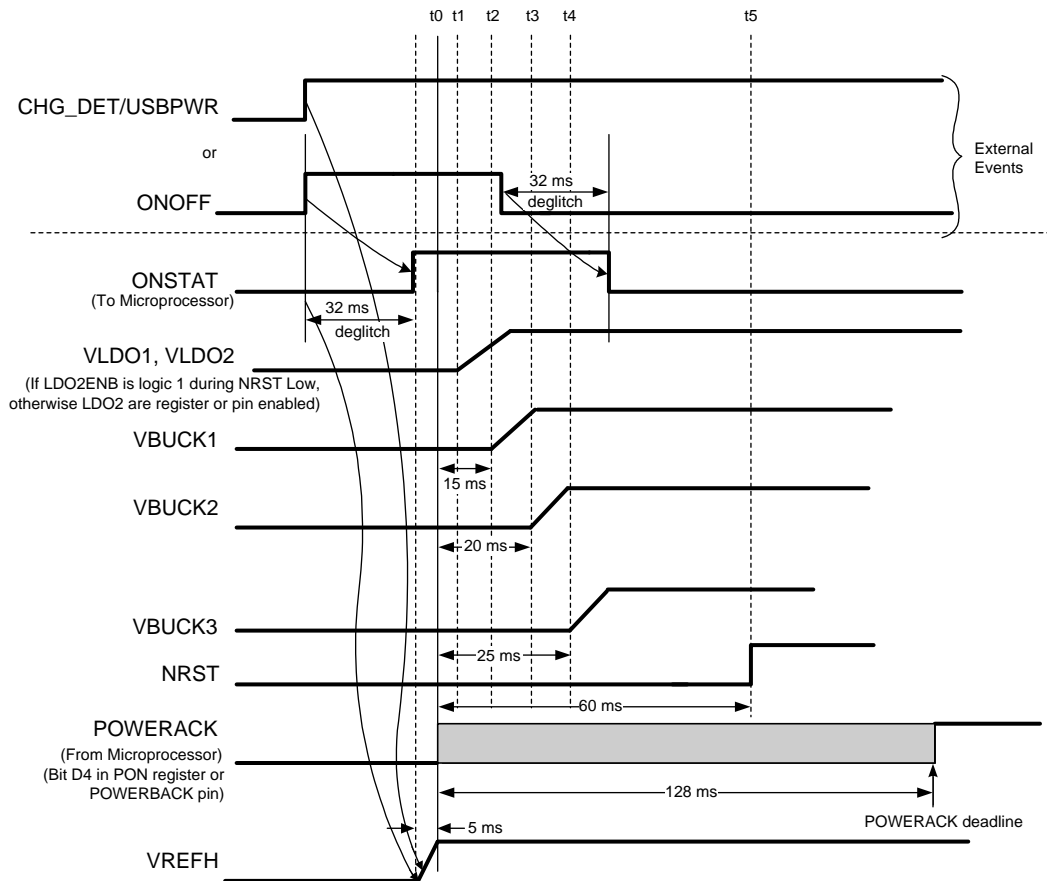

Transitioning From Active Mode To Standby Mode

External Event Triggers the Transition from Active to Standby Mode

When the device is active, a subsequent re-assertion of the push button will turn off the LP3913 indirectly by first flagging the system processor through the ONSTAT pin. Upon detecting the ONSTAT transition, the system processor must clear bit D4 (PACK) in the Power On Event Register and apply a logic low to the POWERACK pin to power down the LP3913, which then transitions to Standby Mode. Clearing the PACK register bit and POWERACK pin while external supply sources are present (either USB or CHG_IN) will *not* power down the LP3913, to keep the charger active. The system can as always disable all necessary DC/DC converters, except BUCK1, through the register control.

When external power is disconnected, LP3913 will remain in its Active state unless the battery voltage is below V_{BLA} (Battery Low Alarm) or unless the PACK (either bit D4 in the PON register and the POWERACK pin) is cleared by the system processor.

Figure 57. Power Down Caused by External Event

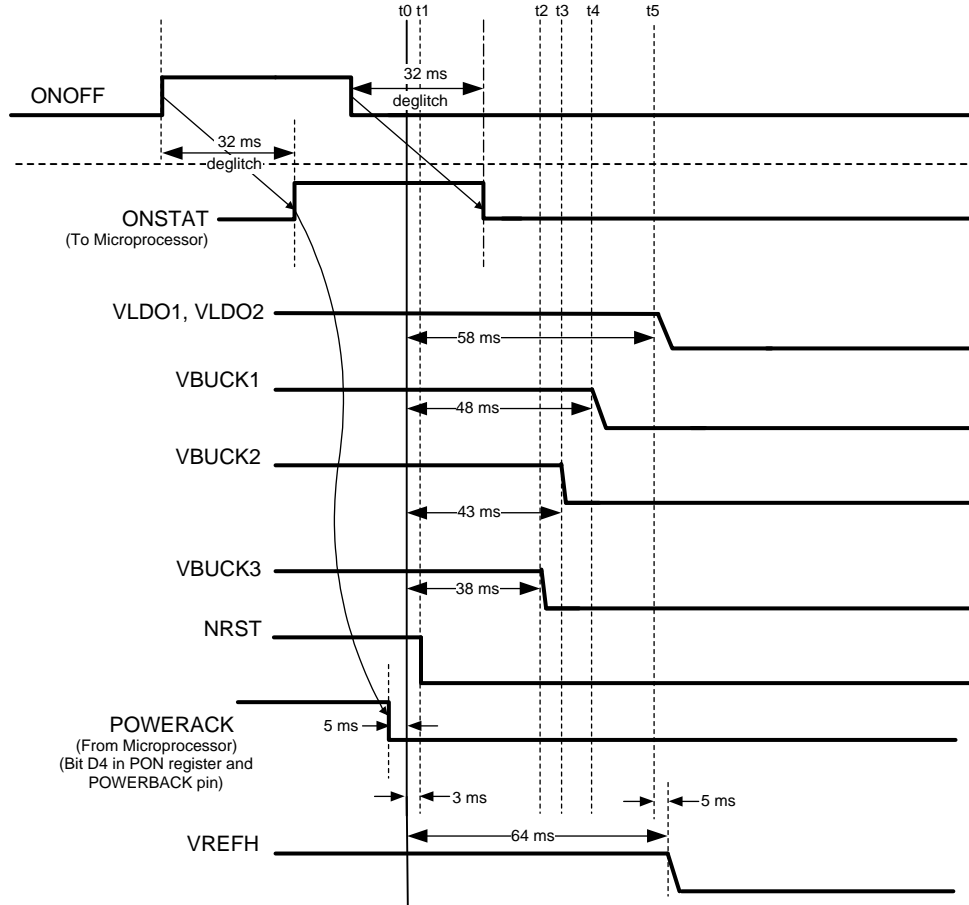

Transition from Active to Standby Mode Due to Expiring POWERACK Deadline

With no external charger present when the system processor fails to acknowledge the power-on in time by setting either the PACK bit (D4) in the PON register or the POWERACK pin before the 128 ms deadline following the start of the power-up sequencer, then the NRST is immediately de-asserted and after 2 ms all power sources will be disabled before transitioning to Standby Mode. This 2 ms delay allows the microprocessor to receive a clean reset before the power is de-asserted. A new power-on event is then required to transition back to Active mode.

With either external charger present when the system processor fails to acknowledge the power-on in time by setting either the PACK bit (D4) in the PON register or the POWERACK pin before the 128 ms deadline following the start of the power-up sequencer, then the NRST is immediately de-asserted and after 2 ms all power sources will be disabled before transitioning to Charger Standby Mode.

Figure 58. Power Down Caused by Expiring PowerACK Deadline

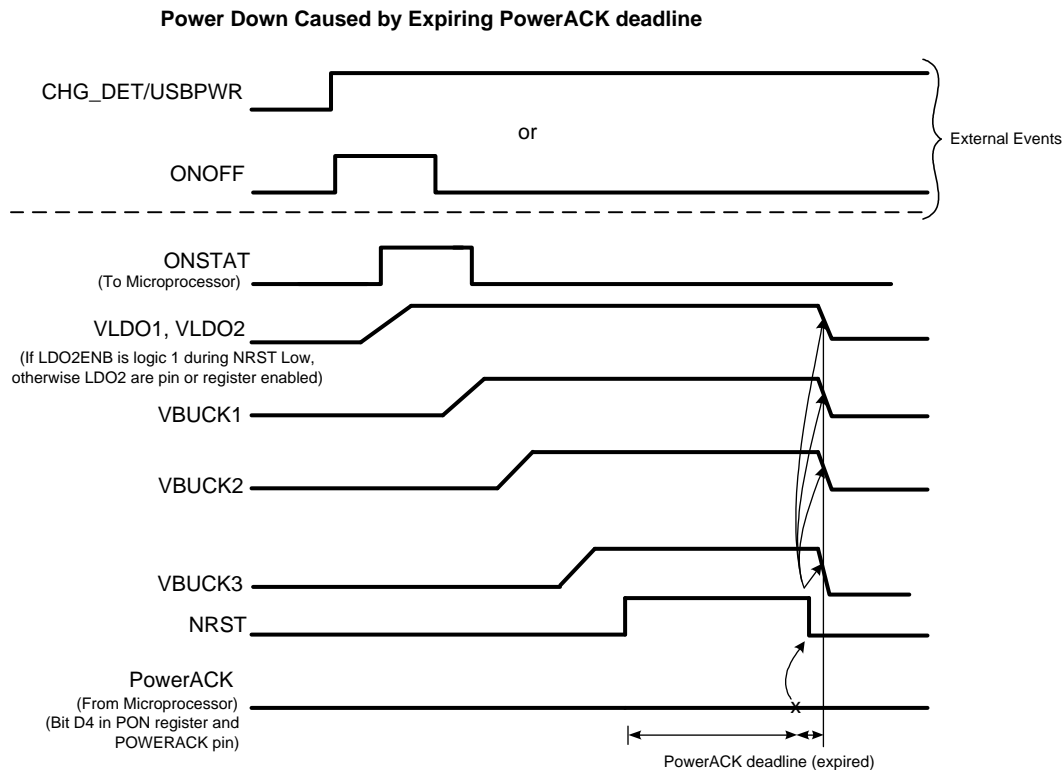

Transition from Charger Standby Mode to Either Active or Standby Mode

While in Charger Standby mode, the battery is charged using the default values of I_{PROG} , EOC , V_{TERM} , Batt Temp Range and USB I_{SEL} . In Charger Standby mode, all the regulators and the I²C are disabled. A new power-on event is required to transition back to Active Mode. Removing the charger during Charger Standby Mode causes a transition back to Standby Mode.

I²C-Compatible Serial Interface

I²C Signals

The LP3913 features an I²C compatible serial interface, using two dedicated pins: I²C_SCL and I²C_SDA for I²C clock and data respectively. Both signals need a pull-up resistor according to the I²C specification. The LP3913 interface is an I²C slave that is clocked by the incoming SCL clock.

Signal timing specifications are according to the I²C bus specification. The maximum bit rate is 400 kbit/s. See I²C specification from Philips for further details.

I²C Data Validity

The data on I²C_SDA line must be stable during the HIGH period of the clock signal (I²C_SCL), e.g., the state of the data line can only be changed when CLK is LOW.

Figure 59. I²C Signals: Data Validity

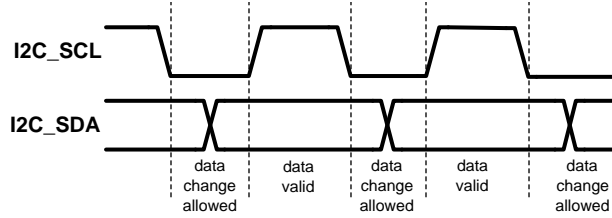

I²C START and STOP Conditions

START and STOP bits classify the beginning and the end of the I²C session. The START condition is defined as the I²C_SDA signal transitioning from HIGH to LOW while SCL line is HIGH. The STOP condition is defined as the SDA transitioning from LOW to HIGH while I²C_SCL is HIGH. The I²C master always generates START and STOP bits. The I²C bus is considered to be busy after a START condition and free after a STOP condition. During data transmission, I²C master can generate repeated START conditions. First START and repeated START conditions are equivalent, function-wise.

Figure 60. START and STOP Conditions

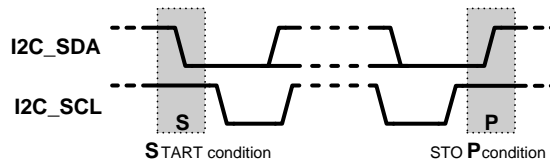

Transferring Data

Every byte put on the I²C_SDA line must be eight bits long, with the most significant bit (MSB) being transferred first. Each byte of data has to be followed by an acknowledge bit. The acknowledged related clock pulse is generated by the master. The transmitter releases the I²C_SDA line (HIGH) during the acknowledge clock pulse. The receiver must pull down the I²C_SDA line during the 9th clock pulse, signifying acknowledgement. A receiver which has been addressed must generate an acknowledgement (“ACK”) after each byte has been received.

Register Write Cycle

After the START condition, the I²C master sends a chip address. This address is seven bits long followed by an eighth bit which is a data direction bit (R/W). For the eighth bit, a “0” indicates a WRITE and a “1” indicates a READ. The second byte selects the register to which the data will be written. The third byte contains data that will be written to the selected register.

LP3913 has a chip address of 60'h, which is set by a metal mask option.

Figure 61. I²C Chip Address

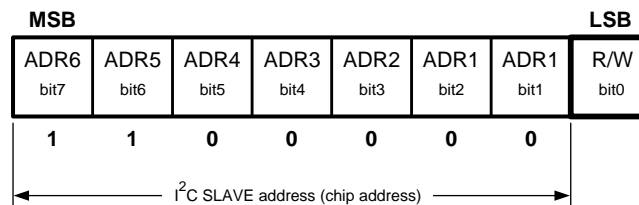
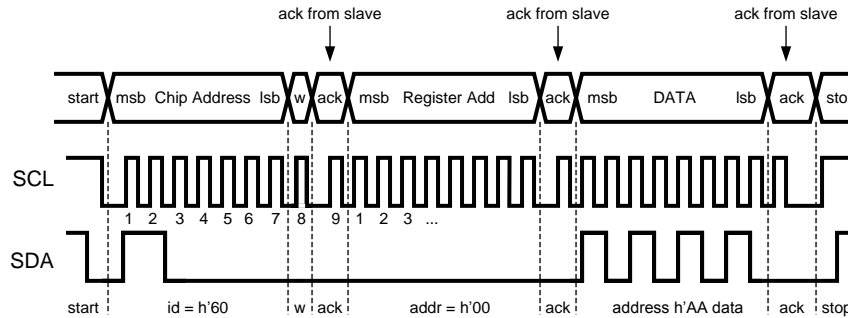

Figure 62. I²C Write Cycle



w = write (I²C_SDA = "0")
 r = read (I²C_SDA = "1")
 ack = acknowledge (I²C_SDA pulled down by either master or slave)
 rs = repeated start
 id = LP3913 chip address : 60'h

Register Read Cycle

When a READ function is to be accomplished, a WRITE function must precede the READ function, as shown in the Read Cycle waveform.

Figure 63. I²C Read Cycle

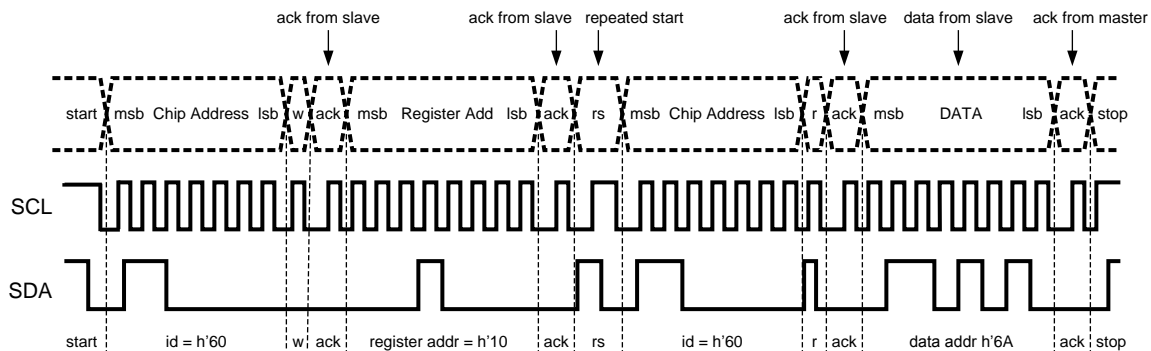

Multi-byte I²C Command Sequence

The LP3913's I²C serial interface shall support Random register Multi-byte command sequencing: During a multi-byte write the Master sends the Start command followed by the Device address, which is sent only once, followed by the 8-bit register address, then 8 bits of data, The I²C slave must then accept the next random register address followed by 8 bits of data and continue this process until the master sends a valid stop condition.

A Typical Multi-byte random register transfer is outlined below:

Device Address, Register A Address, Ack, Register A Data, Ack Register M Address, Ack, Register M Data, Ack Register X Address, Ack, Register X Data, Ack Register Z Address, Ack, Register Z Data, Ack, Stop

NOTE

The PMIC is not required to see the I²C device address for each transaction. A, M, X, and Z are random numbers



Li-Ion Linear Charger

Charger Architecture

The LP3913 can safely charge and maintain a single cell Li-Ion/Polymer battery operating off a regulated 6V Car adapter, AC wall adapter, or USB power (VBUS). Input power source selection of USB/adaptor is seamless. If present, the charger will use the adapter power regardless of the presence of USB power. The connection of either power source is detected by LP3913.

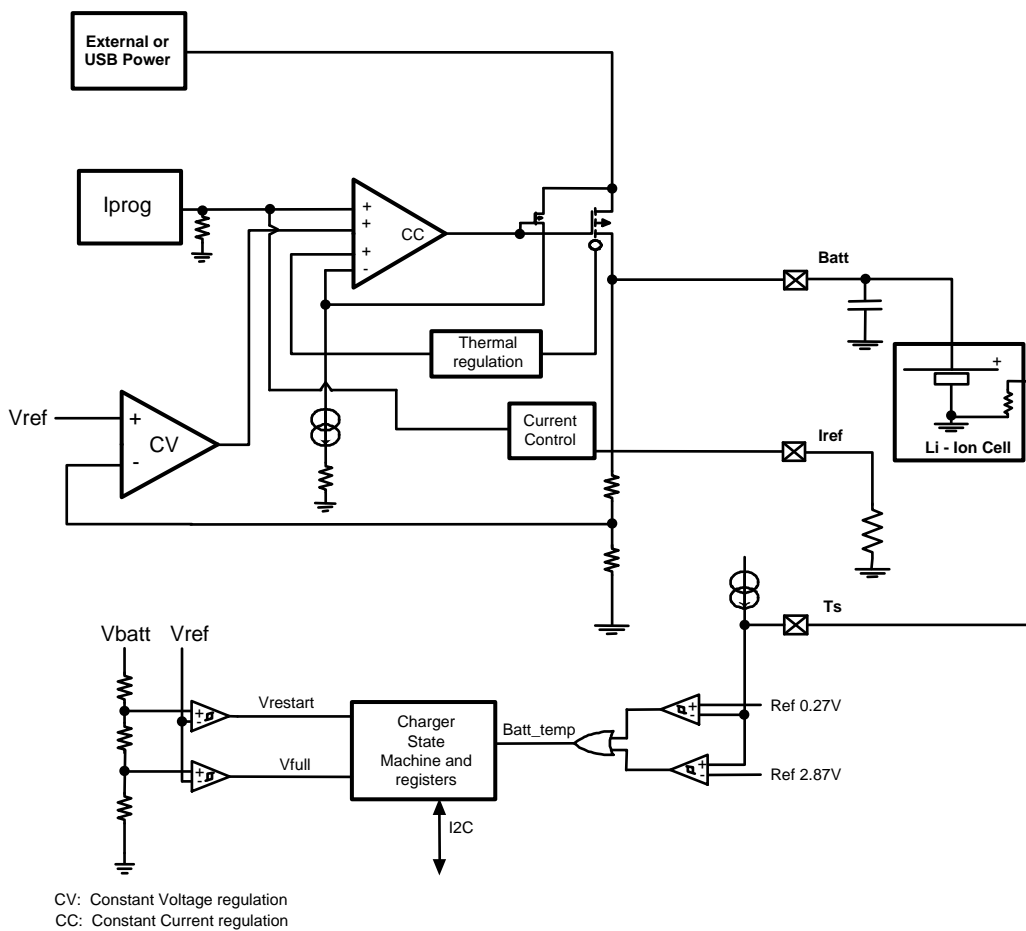

The charger module is a linear charger with constant current pre-qualification, constant current (“CC”) full-rate charging and constant voltage (“CV”) charging. CC and CV regulation is performed using an internal Power FET Q2 with reverse current blocking. The termination voltage is controlled to within $\pm 0.35\%$ at room temperature.

The power FET Q1 acts as a switch with programmable current limit for USB operation.

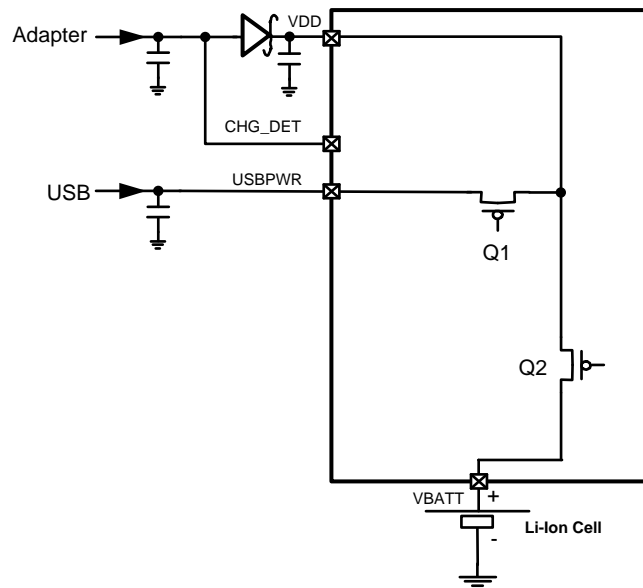

Charge Status Indication

Two LEDs connected to the LP3913 are used to indicate the status of the charging. The CHG pin is connected to a red LED that is enabled when an external power source is connected and the battery is charging. The second STAT pin is connected to a green LED. When the battery charging transitions from CC to CV mode, then the green LED is blinking with a 50% duty cycle and a period of 1 second. When the battery is fully charged, then the green LED is always on.

Both LEDs are off when there is no external power connected.

Table 3. Truth Table for the LED Status Indicators

Condition	RED LED	GREEN LED
No Charger or USB	OFF	OFF
Charger off	ON	OFF
Pre-Qualification	ON	OFF
Constant Current CC	ON	OFF
Constant Voltage CV	ON	50% duty cycle
EOC / Top-OFF charging	ON	ON
Charge cycle complete	ON	ON
ERROR (Battery Temp, Thermal shutdown)	50% duty cycle	OFF
Safety Timer Expired	50% duty cycle	OFF

50% duty cycle indicates the LED is pulsed on/off for equal times at a frequency of 1 Hz.

The RED pin and GREEN pin are connected to a regulated driver to ensure that the brightness is independent from the external power. The LEDs need to be connected between the CHG / STAT pins and GND.

Thermal Charger Power FET Regulation

The internal power FET Q2 in the linear charger module is thermally regulated to the junction temperature of 115°C to ensure optimal charging of the battery. The charge current is limited by the charge current selected in the Charger Control Register but is also thermally limited to prevent the junction from overheating during high charge currents at high ambient temperatures as the package power dissipation is limited.

Thermal regulation ensures maximum charge current and superior charge rate without exceeding the power dissipation limits of LP3913.

CHCTL Register (01)h Charger Control Register

	D7–6	D5–2	D1	D0
Access	rw			
Data	Termination voltage	I_{CC}: Full Rate Charge current	Charger enable	End of Charge Select
	00: 4.1V (Li Ion) 01: 4.2V (Li Polymer) 10: 4.38V (Li Polymer) 11: reserved	0000: 100 mA 0001: 200 mA 0010: 300 mA 0011: 400 mA 0100: 500 mA 0101: 600 mA 0110: 700 mA 0111: 800 mA 1000: 900 mA 1001: 1000 mA	0: disabled 1: enabled	0: 5% 1: 10%
Reset	01	0000	1	1

Battery Charger Operating Modes**Pre-Qualification Mode**

Lithium batteries cannot be subjected to a high current when the battery voltage is under a certain threshold, otherwise the longevity of the battery would be compromised. Below this threshold of $V_{FULLRATE}$, which typically measures 2.85V, the charger circuit supplies a pre-qualification charge current. If the wall adapter is charging the battery, the charger circuit supplies a constant current of 10% of the programmed charge current. If the USB is charging the battery, the charger circuit supplies a constant 50 ma charge current. When the battery voltage reaches V_{FULL_RATE} , the charger transitions from pre-qualification to full-rate charging. In Pre-qualification mode, the STAT2, STAT1, and STAT0 bits in the charger supervisory register are respectively low, low, high.

Full-Rate Charging Mode

The full-rate charge cycle is initiated following the successful completion of the pre-qualification mode. During Full-Rate charging, the battery voltage steadily increases while charged with a constant current (CC). The three charger status bits STAT2, STAT1 and STAT0 are respectively low, high, and low. The full-rate charge current is selected using the Charge Control Register, which defaults to 100 mA.

It is recommended to charge Li-Ion batteries at a rate of 1C, where “C” is the capacity of the battery. As an example, it is recommended to charge a battery with a capacity of 800 mAh at 800 mA, or 1C. Charging at a higher rate may compromise the quality and lifetime of the battery.

Constant-Voltage (CV) Charging Mode

The battery voltage increases rapidly as a result of full-rate charging and once it reaches the programmable termination voltage of either 4.1V, 4.2V or 4.38V, the charger will move to constant-voltage charge mode. During this mode, the charge current gradually decreases while the battery remains at the termination voltage. The termination voltage can be selected to be either 4.1V, 4.2V or 4.38V by programming bits D6 and D7 in the Charger Control register to accommodate different battery chemistries. In CV charging mode, the Charge Control Status bits STAT2, STAT1 and STAT0 are respectively logic 0, logic 1 and logic 1.

TOP-OFF Charging Mode

When the charge current reduces to the EOC threshold (programmable to 5% or 10% of programmed full rate charge current), constant voltage charging will continue for an additional 21 minute TOP-OFF time period. In TOP-OFF charging mode, the Charge Control Status bits STAT2, STAT1 and STAT0 are respectively logic 1, logic 1 and logic 1. At the end of the TOP-OFF period, the charger transitions to Charge Cycle Complete.

Charge Cycle Complete

During Charge Cycle Complete, the charger is automatically disabled, regardless of the state of the Charge Enable Bit. In Charge Cycle Complete, the STAT2, STAT1 and STAT0 bits are respectively logic 1, logic 0 and logic 1. When the Battery Voltage drops below the $V_{RESTART}$ threshold, charging will resume in Full-Rate Charging Mode.

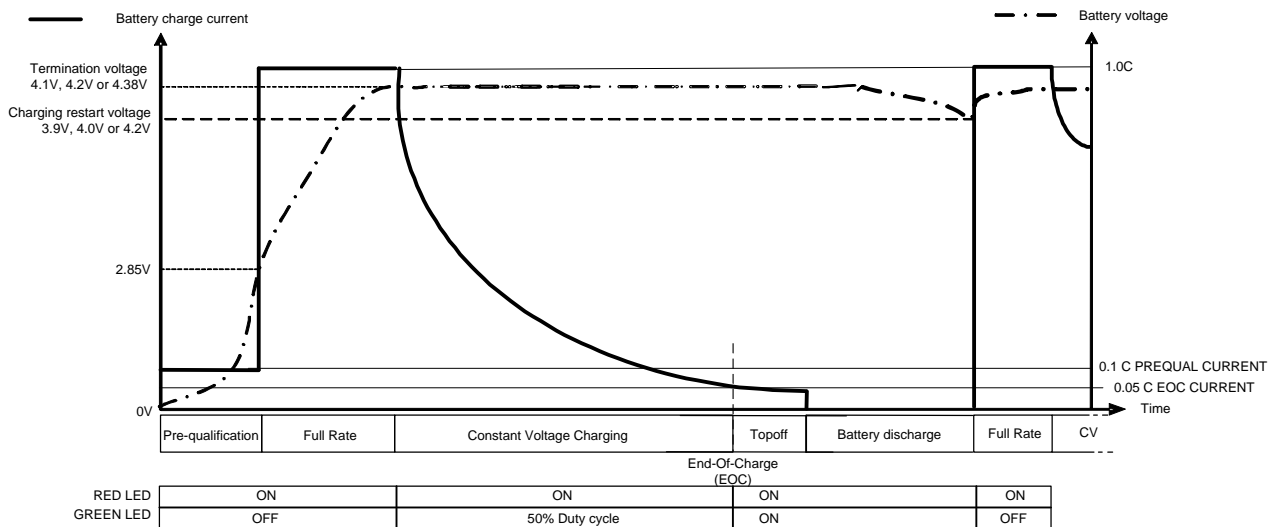

Battery Temperature Monitoring (T_S pin)

The LP3913 is equipped with a battery thermistor terminal to continuously monitor the battery temperature by measuring the voltage between the T_S pin and GND. With the T_S pin connected to the battery thermistor, charging is allowed only if the battery temperature is within the acceptable temperature range set by a pair of internal comparators inside the LP3910. The temperature window is 0°C–45°C or 0°C–50°C, depending on the setting of D2 of the Charger Supervisory (CHSPV) register. There is 3°C of temperature hysteresis associated with each temperature threshold. The default temperature range is 0°C–50°C and can be changed to 0°C–45°C by setting bit D3 in the CHSPV register. If the battery temperature is out of range, STAT2, STAT1 and STAT0 bits in the CHSPV Register are set to logic1, logic0, logic0, and charging is suspended.

The T_S pin is only active during charging and draws no current from the battery when no external power source is present.

If the T_S pin is not used in the application, it should be connected to GND through a 100 kΩ pulldown resistor.

When the T_S pin is left floating (battery removal), then the charger will be disabled as the T_S voltage exceeds the lower temperature limit.

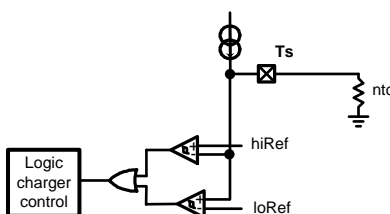

Disabling Charger

Charging can be safely interrupted by clearing the Charge enable bit D1 in the Charge Control Register and can subsequently resume upon setting this bit. When the charger is disabled, STAT2, STAT1, and STAT0 bits in the CHSPV register are set to logic 0.

Safety Timer

In order to prevent endless charging, which could degrade the battery quality and life time, the LP3913 contains a safety timer that limits charging regardless whether the battery has reached its full capacity or not. In prequalification the safety timer is 1 hour. In full rate or constant voltage charging the safety timer is a maximum of 10 hours minus the time in prequalification.

When the timer times out of uninterrupted charging, an IRQ is generated to alert system processor. The status of the timer can also be polled by reading the IRQ register if the system doesn't support hardware interrupts.

The Safety timer resets and starts counting from zero upon the following events:

1. Power ON (through connecting valid power to either USBPWR or CHGN_IN pins).
2. Interchanging USBPWR and CHG_IN sources
3. The voltage of a charged battery drops below the restart value and the charger is enabled
4. Disabling and re-enabling of the charger by toggling bit D1 of the Charge Control Register
5. Emerging from Thermal Shutdown
6. Emerging from a battery temperature out-of-range and the charger is enabled
7. Emerging from USB suspend mode when charging with USB power

Charging Maintenance

When a fully charged battery is being loaded by the system while the external power is present and while bit D1 in the charge control register is set to a 1 (Charge enable) then the charging will restart when the battery voltage drops below the charging restart threshold. The value of the threshold depends on the termination voltage according to the following table:

Vterm	Charging restart voltage
4.1V	3.9V
4.2V	4.0V
4.38V	4.2V

CHSPV Register (02)h Charger Supervisor Register

	D7–6	D5	D4	D3	D2–0			
Access	Read only	r/w	r/w	r/w				
Data	Reserved	LED Current	LED ENABLE 0: Disabled 1: Enabled	Battery temperature range	Charger status			
		0: 5 mA			0: 0°C–50°C	Stat2	Stat1	Stat0
		1: 10 mA		1: 0°C–45°C	0	0	0	Charger is off
					0	0	1	Prequalification
					0	1	0	Constant current charging
					0	1	1	Constant voltage charging
					1	0	0	Error
					1	0	1	Charge cycle complete
					1	1	0	Safety Timer Expired
					1	1	1	EOC / Top-off
Reset	n/a	1	1	0	2'b000			

Power Routing

The LP3913 power can originate from three different sources: Adapter power, USB power or battery power. The objective of the power routing is to be able to:

- Operate the portable system from external power regardless of the battery voltage.
- Operate the portable system from USBPWR when the battery exceeds the Full Rate Qualification Threshold voltage (Vfullrate).
- Concurrently charging and operating the system when external power is present
- Seamless selection of Adapter or USB power as the primary external power source

Power Routing supports 4 modes:

1. A regulated external adapter power is present and concurrently supplies the system power and the battery

charger.

2. USB power is present and supplies the system and the battery.
3. USB power is present but the system demand exceeds the USB current limit, so that the battery provides the additional power to operate the system.
4. The battery is the sole supply source to the system when no external power source is present

The current flows in the different modes are realized through internal FETS and an external Schottky as illustrated as follows:

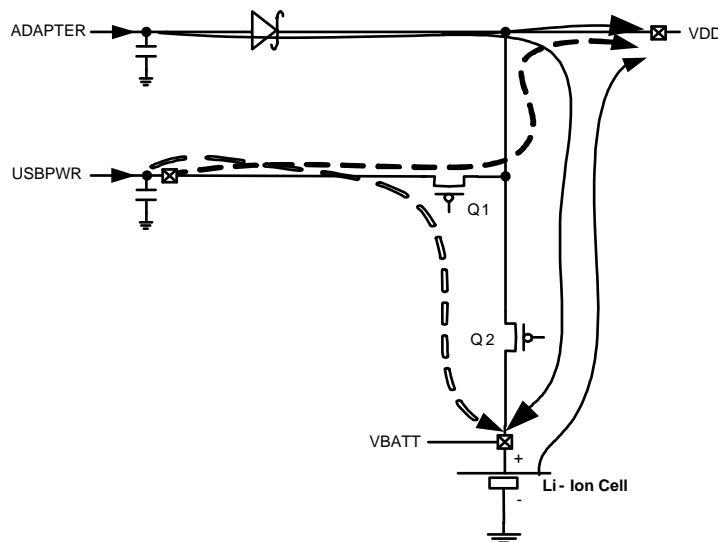

The current provided by the external adapter power or USB power, when inserted, first supplies the system load; the remainder is used for charging.

The different paths are configured through two internal power FETs, Q1 and Q2, and an external Schottky diode. Q1 is a Power FET that is only active during USB charging. Q2 functions either as a linear Power FET during charging or as a low $R_{\text{DS(on)}}$ switch when no external power is present and the battery discharges to supply power to the system.

Power Route	Q1	Q2
Regulated adapter supply & battery charging	OFF	Regulated
USB supply & battery charging	ON	Regulated
No external supply & battery discharging	OFF	ON

The Power Routing function will allocate power to the system through the V_{DD} pin and to the battery. $V_{\text{DD}1}$, $V_{\text{DD}2}$, $V_{\text{DD}3}$, $V_{\text{IN}1}$, $V_{\text{IN}2}$, $V_{\text{IN}3}$, and $V_{\text{IN}4}$ must be connected together externally. $V_{\text{BATT}1}$, $V_{\text{BATT}2}$, and $V_{\text{BATT}3}$ must be connected together externally.

USB Suspend Mode

The LP3913 USB current consumption can be disabled during suspend mode through a dedicated pin (USBSUSP). Applying a logic 1 to this pin will disable the USB current path and current is reduced to input leakage current less than 30 μA on the USBPWR pin.

Setting the USB Current Limit

The USB current that is available from the USB on the VBUS wire is limited by default to 100 mA. More current (up to 800 mA) can be negotiated through a session request protocol between host and peripheral. The USB current limit needs to be signaled to the LP3913 by means of the USB_{ISEL} pin or the I_{LIMIT} Register as indicated below.

If the USB current limit is 100 mA then the USB controller of the peripheral system needs to set the USB_{ISEL} logic 0 or by setting the I_{LIMIT} register bits [D1, D0] to 2'b00.

If the USB current limit is 500 mA, then the USB controller needs to apply logic 1 to the USB_{ISEL} pin or change the I_{LIMIT} register accordingly. Under this condition, the LP3913 will allow charging with a charge current that is determined by the Charge Control Register, not exceeding 500 mA.

The LP3913 will prevent (through internal circuitry) the charge current from exceeding the USB current limit, even if the current setting in the Charge Control Register exceeds 500 mA.

The controller can also select a USB current limit of 800 mA through I²C that exceeds current USB spec values.

I_{LIMIT} Register (03)h Current Limit Register

	D7–2	D1–0
Access	Read only 0	
Data	Reserved	USB Current Limit
		00: controlled by USB _{ISEL} pin [low = 100 mA, high = 500 mA] 01: 100 mA 10: 500 mA 11: 800 mA
Reset	n/a	2'b00

Analog-to-Digital Converter

LP3913 is equipped with an 8-bit dual-slope integrating analog-to-digital converter. Dual-slope converters provide effective filtering of >500 kHz and <125 kHz noise components on the input voltage, and does not require a sample and hold stage. The A/D converter core digitizes the input voltage ranging from V_{REF} to 2V_{REF}, where V_{REF} is the voltage measured on the V_{REFH} pin. After an initial 2 ms warm-up for the first activation of the ADC enable bit, the dual-slope converter integrates the input signal during the first phase for approximately 2 ms, followed by a second phase that integrates V_{REF} for 0 ms to 2 ms depending on the level of the input signal. As a result the total conversion time varies from 2 ms to 4 ms.

Figure 64. Simplified ADC Block Diagram

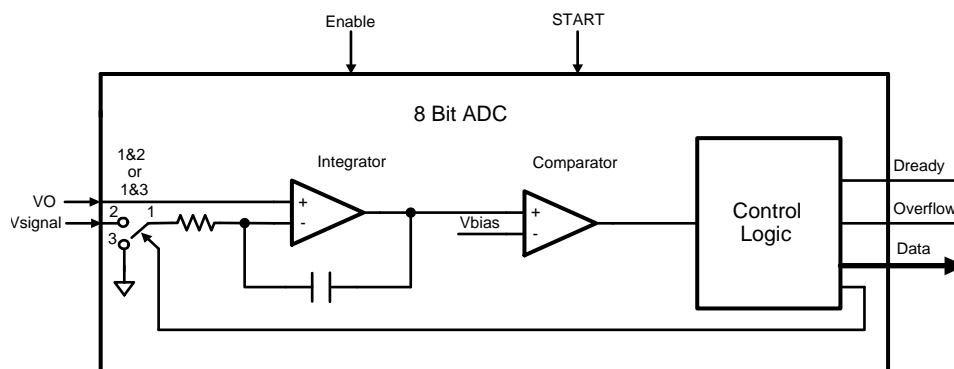

The A/D converter multiplexes 4 different sources:

1. The battery voltage
2. The battery charge current
3. External source ADC1
4. External source ADC2

The voltage ranges for the first two sources are scaled to match the input voltage interval of the A/D converter: [V_{REFH}, 2V_{REFH}]. This is accomplished by using two internal scalars.

Battery Voltage Measurement

The battery voltage scalar transforms the battery voltage ranging from 2.6V–3.5V to the reference voltage interval: $[V_{REFH}, 2 \cdot V_{REFH}]$. A wider voltage range (2.6V–4.4V) can be selected through I²C by setting the voltage range bit D7 in register 0xA to 0'b1.

Battery Charge Current Measurement

The battery charge current is indirectly measured by measuring the voltage across the I_{SENSE} resistor. A fixed portion of the battery charge current is mirrored over the I_{SENSE} resistor and hence:

$$V_{ISENSE} = K \cdot I_{CHARGE} \tag{1}$$

where K is a ratio between the R_{SENSE} current and the charge current.

The battery charge current scalar transforms the voltage across the external I_{SENSE} resistor to the $[V_{REFH}, 2 \cdot V_{REFH}]$ input voltage interval of the A/D converter.

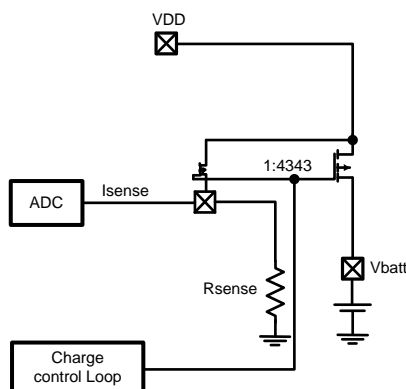

External General Purpose Sources

Two additional A/D converter sources are available on the ADC1 and ADC2 pins of the LP3913. These two external A/D converter sources are not internally scaled and have an input voltage range of $[V_{REFH}, 2 \cdot V_{REFH}]$. The system designer can use these two sources for general purpose applications such as resistive keyboard matrix scanning, temperature measurements, battery load current, battery ID resistor measurement, etc.

Figure 65. ADC Analog Front End Block Diagram

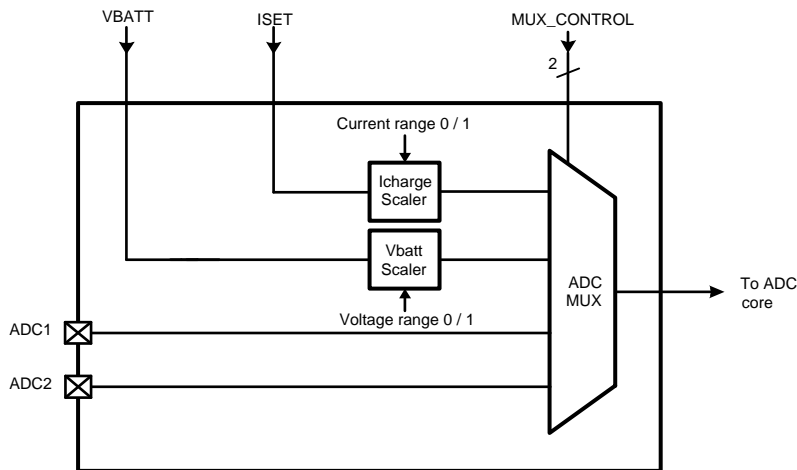

The source selection and the access to the conversion results are established through the I²C linked control registers: ADCC and ADCD as described below:

ADCC Register (0a)h A/D Converter Control Register

	D7	D6	D5	D4	D3	D2	D1–0
Access	r/w	r/w	Read Only		r/w	r/w	
Data	V _{RANGE}	I _{RANGE}	ADC Overflow	Data Ready	Start Conversion	ADC Enable	ADC source selection
	0: 2.6V–3.5V	0: 0 mA–605 mA	0: no overflow	0: no data	0: default	0: Disabled	00: battery voltage
	1: 2.6V–4.4V	1: 0 mA–1100 mA	1: overflow	1: data ready	1: start conversion	1: Enabled	01: battery charge current
							10: ADC1
							11: ADC2
Reset	0	0	0	0	0	0	0

ADCD Register (0b)h A/D Converter Output Data Register

Charge current 0A to 1.1A mirrored to 0 μ A to 250 μ A, ADC measures voltage drop across R_{SENSE} 4.64 k Ω .

	D7–0	
Access	Read Only 0	
Data	Battery voltage:	8'h00 = 2.6V 8'hFF = 3.5V 1 LSB = 0.9 / 256 = (3.5 mV) range 0
		8'h00 = 2.6V 8'hFF = 4.4V 1 LSB = 1.8 / 256 = (7.0 mV) range 1
	Battery charge current	8'h00 = 0 8'hFF = 0.6463V = 605 mA range 0
		8'h00 = 0 8'hFF = 1.175V = 1100 mA range 1
	ADC1:	8'h00 = V _{REFH} = 1.225V 8'hFF = 2*V _{REFH} = 2.45 V (1 LSB = V _{REFH} /256)
	ADC2:	8'h00 = V _{REFH} = 1.225V 8'hFF = 2*V _{REFH} = 2.45 V (1 LSB = V _{REFH} /256)
Reset	8'h00	

The ADC is by default disabled to minimize current consumption and needs to be enabled by setting D2 in the ADCC register. Writing a logic 1 to bit D3 in the ADC will initiate a conversion. It is advised to select the correct ADC source before a conversion is started. The A/D converter will set bit D4 in the ADCC register upon the completion of a conversion, which is typically 4 ms after the start of the conversion. At the same time an interrupt request will be generated. (See [IRQ Register \(0d\)h Interrupt Request Register](#)).

To save power, disable the ADC by setting bit 2 of D2 to 0. To make repetitive starts, set bit D3 to 0 then to 1 for register 0Ah to initiate start of conversion. The interrupt driven protocol between LP3913 and the system processor is the most efficient way to acquire data from successive measurements:

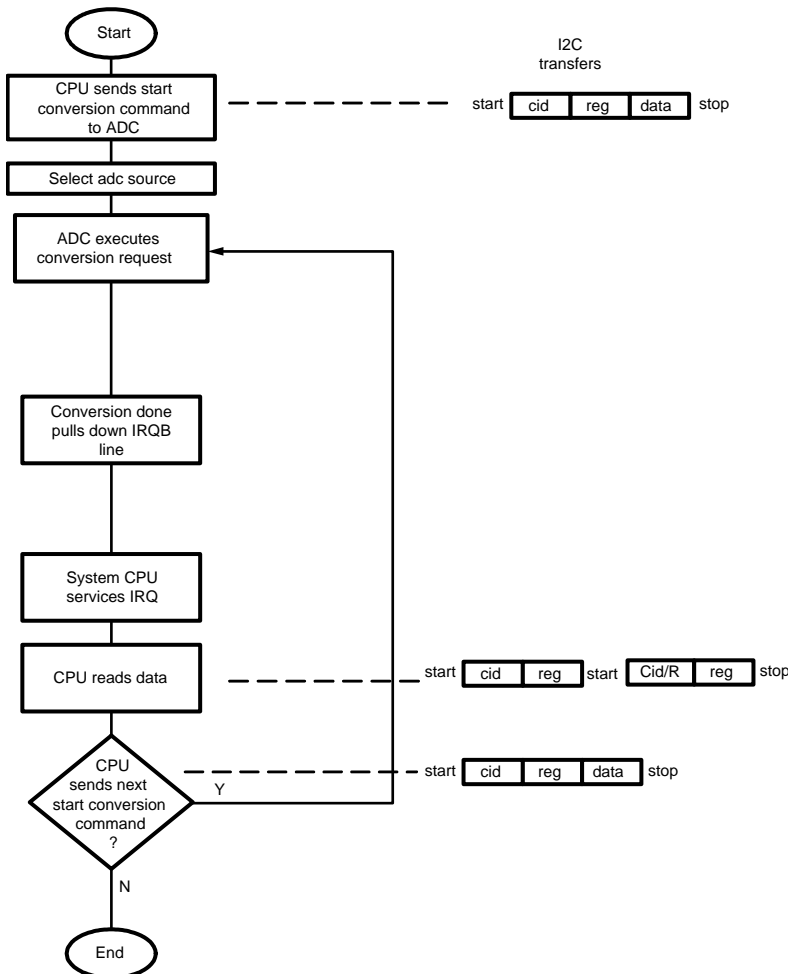

Interrupt Request Output

The LP3913 has the ability to interrupt the system processor through the open drain IRQB pin, which transitions to an active logic low level upon the following 8 events:

- USB Power detected
- USB disconnected
- CHG_IN Power detected
- CHG_IN Disconnected
- Battery low alarm
- Thermal Alarm
- ADC conversion completed
- Charger safety timer time-out

The events form the interrupt sources that correspond to a certain bit location in the Interrupt Request (IRQ) Register. All interrupt sources can be masked by the Interrupt Mask Register (IMR). Masking the interrupt prevents the interrupt event from asserting the IRQB pin, yet the event will still be captured in the IRQ register, which allows the processor to poll the interrupt sources.

After an active low IRQB has been detected by the system processor, the latter services the interrupt and will access the IRQ register to determine which source was responsible for the interrupt request. Reading the IRQ register will automatically clear the register to enable the capture of the next interrupt events.

As new interrupts can occur while the I²C read cycle is clearing the IRQ register, a buffer register called Interrupt Pending Register (IPR), not accessible through the I²C compatible interface holds the next interrupts. De-asserting the IRQB output is immediately followed by a new transition of IRQB to logic low when an interrupt is pending.

The Interrupts are not hardware prioritized. It is up to the firmware to determine the priority in case more than one Interrupt Request is set.

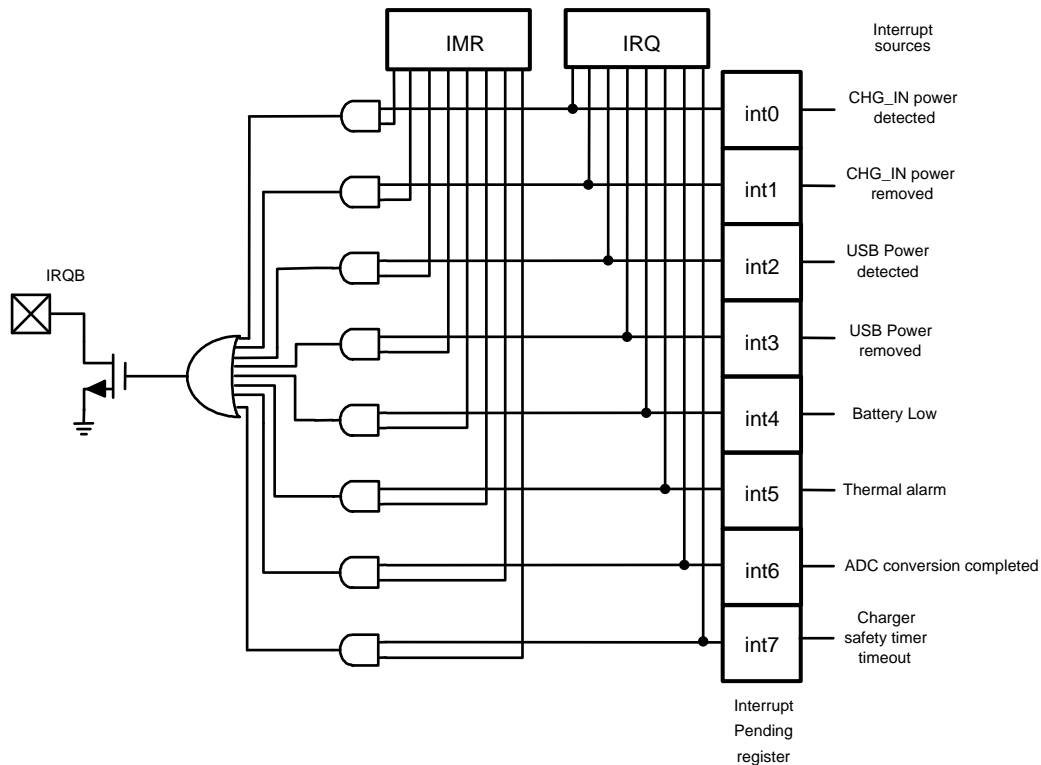

Interrupts and Standby Mode

Interrupts are captured in standby mode and can be serviced when the system processor is enabled when the LP3913 is in an active state.

Interrupt Sources

CHG_IN Power Detected and CHG_IN Disconnect (INT0 and INT1) An interrupt (INT0) is generated when CHG_IN power is connected to the LP3913. Another interrupt (INT1) will be generated upon CHG_IN power removal.

USB Power Detected and USB Disconnect (INT2 and INT3) An interrupt (INT2) is generated when USB power is connected to the LP3913. Another interrupt (INT3) will be generated upon disconnecting the USB power.

Battery Low (INT4) When the battery voltage drops below the battery low threshold IRQ, an interrupt will be generated. This allows the processor to perform some housekeeping tasks prior to going to standby mode.

Thermal Alarm (INT5) If the Junction Temperature of the LP3913 exceeds 115°C, then an interrupt will be generated.

ADC Conversion Done (INT6) The ADC generates an interrupt request upon the completion of a data conversion.

Charger Timer Interrupt (INT7) A charger timeout will occur 10 hours after it started (see [Li-Ion Linear Charger](#)) and will subsequently request an interrupt.

IMR Register (0c)h Interrupt Mask Register

	D7–0
Access	r/w
Data	1: Enable INTn (n=0...7) to pull IRQB low 0: Mask Interrupt source INTn
Reset	8'h00

IRQ Register (0d)h Interrupt Request Register

	D7–0
Access	Read only
Data	1: Interrupt IRQn (n=0...7) requested 0: No interrupt requested
Reset	8'h00

DC/DC Converters
Overview

The LP3913 provides the DC/DC converters that supply the various power needs of the application by means of one Buck3 (HDD driver), two Linear Low Drop Regulators (LDO1, LDO2) and two Buck converters (BUCK1, BUCK2).

The following table lists the output characteristics of the various regulators.

Supply Specification

Supply	Load	V _{OUT} (Volts)			I _{MAX} Maximum Output Current (mA)
		Default (V)	Range (V)	Resolution (mV)	
LDO1	various	2.0	1.2 to 3.3	100	150
LDO2	analog	3.3	1.3 to 3.3	100	150
BUCK1	CPU, DSP	1.2	0.8 to 2.0	50	600
BUCK2	IO, Logic, Memories	3.3	1.8 to 3.3	100	600
BUCK3	Flash	3.3	1.8 to 3.3	50	500

Linear Low Dropout Regulators (LDOS)

LDO1 is a regulator that can respond to fast transients and is slated for digital loads and high bandwidth analog loads. LDO2 is a linear regulator with a similar architecture but has a slower transient response time with a lower noise performance to supply analog loads. The output voltages of both LDOs are register programmable through the I²C interface. The default output voltages are factory programmed during Final Test.

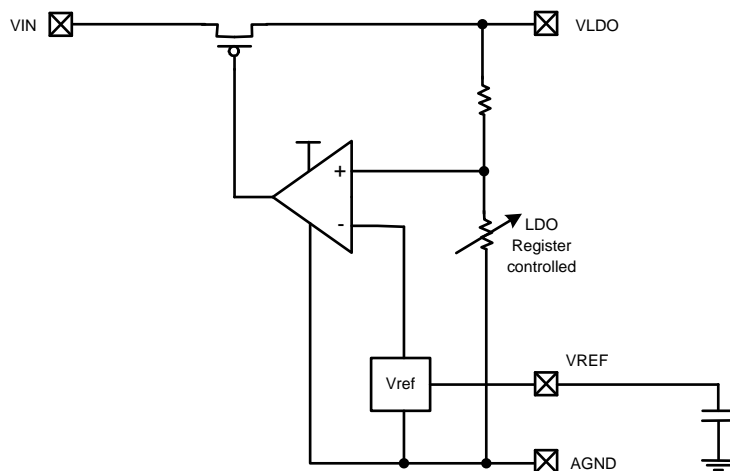

No-Load Stability

The LDOs will remain stable and in regulation with no external load. This is an important consideration in some circuits, for example CMOS RAM keep-alive applications.

LDO1 Control Register

LDO1 can be configured through its own I²C control register. The output voltage is programmable in steps of 100 mV from 1.2V to 3.3V. LDO1 gets enabled during the power-on sequence. Disable/enable control is provided through bit D5 in the LDO1 control register after selecting the appropriate D4–0 settings, which determine the output voltage.

The output voltage can be altered while LDO1 is enabled. When LDO1 is disabled it shunts the output to AGND with a $R_{SHUNT} = 200\Omega$ (Max.).

LDO1 Control Register (08)h

	D7–6	D5	D4–0																																														
Access	Read Only 0	R/W																																															
Data	Reserved	Operation 0: disable 1: enable	<table border="1"> <thead> <tr> <th colspan="2">LDO1 Output Voltage (V)</th> </tr> </thead> <tbody> <tr><td>5'h00</td><td>1.2</td></tr> <tr><td>5'h01</td><td>1.3</td></tr> <tr><td>5'h02</td><td>1.4</td></tr> <tr><td>5'h03</td><td>1.5</td></tr> <tr><td>5'h04</td><td>1.6</td></tr> <tr><td>5'h05</td><td>1.7</td></tr> <tr><td>5'h06</td><td>1.8</td></tr> <tr><td>5'h07</td><td>1.9</td></tr> <tr><td>5'h08</td><td>2.0</td></tr> <tr><td>5'h09</td><td>2.1</td></tr> <tr><td>5'h0A</td><td>2.2</td></tr> <tr><td>5'h0B</td><td>2.3</td></tr> <tr><td>5'h0C</td><td>2.4</td></tr> <tr><td>5'h0D</td><td>2.5</td></tr> <tr><td>5'h0E</td><td>2.6</td></tr> <tr><td>5'h0F</td><td>2.7</td></tr> <tr><td>5'h10</td><td>2.8</td></tr> <tr><td>5'h11</td><td>2.9</td></tr> <tr><td>5'h12</td><td>3.0</td></tr> <tr><td>5'h13</td><td>3.1</td></tr> <tr><td>5'h14</td><td>3.2</td></tr> <tr><td>5'h15 –5'h1F</td><td>3.3</td></tr> </tbody> </table>	LDO1 Output Voltage (V)		5'h00	1.2	5'h01	1.3	5'h02	1.4	5'h03	1.5	5'h04	1.6	5'h05	1.7	5'h06	1.8	5'h07	1.9	5'h08	2.0	5'h09	2.1	5'h0A	2.2	5'h0B	2.3	5'h0C	2.4	5'h0D	2.5	5'h0E	2.6	5'h0F	2.7	5'h10	2.8	5'h11	2.9	5'h12	3.0	5'h13	3.1	5'h14	3.2	5'h15 –5'h1F	3.3
LDO1 Output Voltage (V)																																																	
5'h00	1.2																																																
5'h01	1.3																																																
5'h02	1.4																																																
5'h03	1.5																																																
5'h04	1.6																																																
5'h05	1.7																																																
5'h06	1.8																																																
5'h07	1.9																																																
5'h08	2.0																																																
5'h09	2.1																																																
5'h0A	2.2																																																
5'h0B	2.3																																																
5'h0C	2.4																																																
5'h0D	2.5																																																
5'h0E	2.6																																																
5'h0F	2.7																																																
5'h10	2.8																																																
5'h11	2.9																																																
5'h12	3.0																																																
5'h13	3.1																																																
5'h14	3.2																																																
5'h15 –5'h1F	3.3																																																
Reset	n/a	1	5'h08																																														

LDO2 Control Register

LDO2 can be configured through its own I²C control register. The output voltage is programmable in steps of 100mV from 1.3V to 3.3V. LDO2 is by default disabled and can be enabled by setting bit D5 in the control register after selecting the appropriate D4–0 settings, which determine the output voltage. LDO2 can also be enabled through the external LDO2EN pin, which is the default enable control. With a logic 0 programmed to bit D5 in the corresponding control register, enable/disable control is passed onto the LDO2EN pin; a logic 1 applied to this pin enables LDO2 while a logic 0 disables the LDO2. Setting D5 to 1 in the LDO2 control register enables LDO2, regardless of the state of the LDO2EN pin. If the system designer permanently connects the LDO2EN pin to GND, then D5 is simply a enable/disable control bit. If the system design permanently connects the enable pin to V_{DD} , then the LDO is enabled during the power-on sequence and will always be on, regardless of the state of bit D5 in the LDO2 control register. In that particular case, the LDO2 is sequenced with the same timing as LDO1 (see [Power On/Off Sequencing](#)).

The output voltage can be altered while LDO2 is enabled. When LDO2 is disabled it shunts the output to A_{GND} with a $R_{SHUNT} = 200\Omega$ (Max.).

LDO2 Control Register (09)h

	D7–6	D5	D4–0
Access	Read Only 0	R/W	
Data	Reserved	Operation 0: enable/ disable determined by state of LDO2EN pin 1: enable, override LDO2EN state	LDO1 Output Voltage (V)
			5'h00 1.3
			5'h01 1.4
			5'h02 1.5
			5'h03 1.6
			5'h04 1.7
			5'h05 1.8
			5'h06 1.9
			5'h07 2.0
			5'h08 2.1
			5'h09 2.2
			5'h0A 2.3
			5'h0B 2.4
			5'h0C 2.5
			5'h0D 2.6
			5'h0E 2.7
			5'h0F 2.8
			5'h10 2.9
			5'h11 3.0
			5'h12 3.1
			5'h13 3.2
			5'h14 –5'h1F 3.3
Reset	n/a	0	5'h14

BUCK1, BUCK2: Synchronous Step Down Magnetic DC/DC Converters**Functional Description**

The LP3913, incorporates two high efficiency synchronous switching buck regulators, BUCK1 and BUCK2 that deliver a constant voltage from a single Li-Ion battery to the portable system processors, Memory and I/O. Using a voltage mode architecture with synchronous rectification, both bucks have the ability to deliver up to 600 mA depending on the input voltage and output voltage (voltage head room), and the inductor chosen (maximum current capability).

There are three modes of operation depending on the current required: PWM, PFM, and shutdown. PWM mode handles current loads of approximately 70 mA or higher, delivering voltage precision of $\pm 3\%$ with 90% efficiency or better. Lighter output current loads cause the device to automatically switch into PFM for reduced current consumption ($I_Q = 15 \mu\text{A}$ typ.) and a longer battery life. The Standby operating mode turns off the device, offering the lowest current consumption. PWM or PFM mode is selected automatically or PWM mode can be forced through the setting of the buck control register.

Both BUCK1 and BUCK2 can operate up to a 100% duty cycle (PMOS switch always on). Additional features include soft-start, under-voltage lock-out, current overload protection, and thermal overload protection.

Circuit Operation Description

A buck converter contains a control block, a switching PFET connected between input and output, a synchronous rectifying NFET connected between the output and ground (BCKGND pin) and a feedback path. During the first portion of each switching cycle, the control block turns on the internal PFET switch. This allows current to flow from the input through the inductor to the output filter capacitor and load. The inductor limits the current to a ramp with a slope of $V_{IN} - V_{OUT}/L$.

$$\frac{V_{IN} - V_{OUT}}{L} \quad (2)$$

by storing energy in a magnetic field. During the second portion of each cycle, the control block turns the PFET switch off, blocking current flow from the input, and then turns the NFET synchronous rectifier on. The inductor draws current from ground through the NFET to the output filter capacitor and load, which ramps the inductor current down with a slope of

$$\frac{-V_{OUT}}{L} \quad (3)$$

The output filter stores charge when the inductor current is high, and releases it when low, smoothing the voltage across the load.

PWM Operation

During PWM operation the converter operates as a voltage-mode controller with input voltage feed forward. This allows the converter to achieve excellent load and line regulation. The DC gain of the power stage is proportional to the input voltage. To eliminate this dependence, feed forward voltage inversely proportional to the input voltage is introduced.

Internal Synchronous Rectification

While in PWM mode, the buck uses an internal NFET as a synchronous rectifier to reduce rectifier forward voltage drop and associated power loss. Synchronous rectification provides a significant improvement in efficiency whenever the output voltage is relatively low compared to the voltage drop across an ordinary rectifier diode.

Current Limiting

A current limit feature allows the buck to protect itself and external components during overload conditions PWM mode implements cycle-by-cycle current limiting using an internal comparator that trips at 1000 mA (typical).

PFM Operation

At very light loads, the converter enters PFM mode and operates with reduced switching frequency and supply current to maintain high efficiency.

The part will automatically transition into PFM mode when either of two conditions occurs for a duration of 32 or more clock cycles:

The inductor current becomes discontinuous or The peak PMOS switch current drops below the I_{MODE} level

$$\left(\text{Typically } I_{MODE} < 66 \text{ mA} + \frac{V_{IN}}{160\Omega} \right) \quad (4)$$

During PFM operation, the converter positions the output voltage slightly higher than the nominal output voltage during PWM operation, allowing additional headroom for voltage drop during a load transient from light to heavy load. The PFM comparators sense the output voltage via the feedback pin and control the switching of the output FETs such that the output voltage ramps between 0.8% and 1.6% (typical) above the nominal PWM output voltage. If the output voltage is below the 'high' PFM comparator threshold, the PMOS power switch is turned on. It remains on until the output voltage exceeds the 'high' PFM threshold or the peak current exceeds the I_{PFM} level set for PFM mode. The typical peak current in PFM mode is:

$$I_{PFM} = 66 \text{ mA} + \frac{V_{IN}}{80\Omega} \quad (5)$$

Once the PMOS power switch is turned off, the NMOS power switch is turned on until the inductor current ramps to zero. When the NMOS zero-current condition is detected, the NMOS power switch is turned off. If the output voltage is below the 'high' PFM comparator threshold (see Figure 66), the PMOS switch is again turned on and the cycle is repeated until the output reaches the desired level. Once the output reaches the 'high' PFM threshold, the NMOS switch is turned on briefly to ramp the inductor current to zero and then both output switches are turned off and the part enters an extremely low power mode. Quiescent supply current during this 'sleep' mode is less than 30 μA , which allows the part to achieve high efficiencies under extremely light load conditions. When the output drops below the 'low' PFM threshold, the cycle repeats to restore the output voltage to $\approx 1.6\%$ above the nominal PWM output voltage.

If the load current should increase during PFM mode (see Figure 66) causing the output voltage to fall below the 'low2' PFM threshold, the part will automatically transition into fixed-frequency PWM mode.

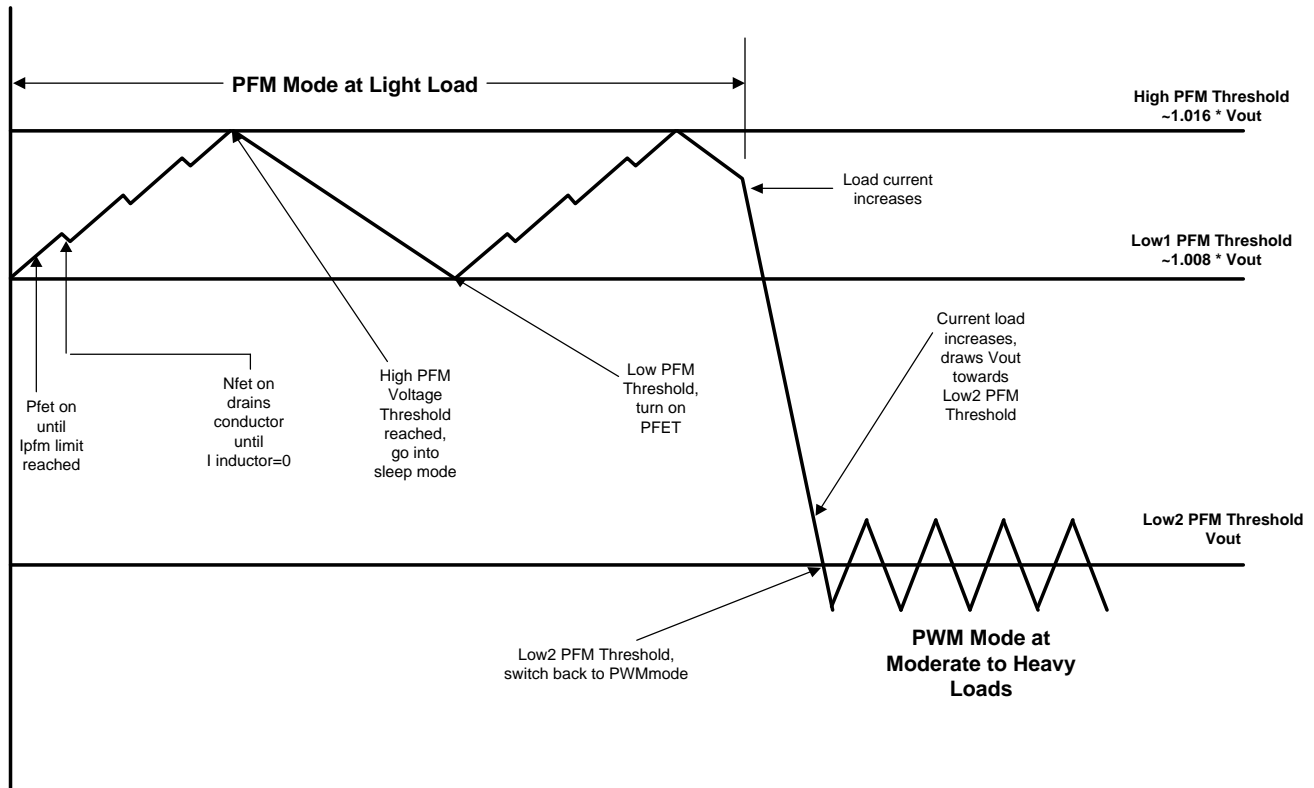

Figure 66.

BUCK1, BUCK2 Operation

BUCK1 is recommended to be used as the processor core supply and has I²C selectable output voltages ranging from 0.8V to 2.0V (Typ.). BUCK2 is recommended for IO power, Memory power and logic power. Its voltage range can be programmed using the I²C interface from 1.8V to 3.3V (Typ.). The default output voltage for each buck converter is factory programmable (See APPLICATIONS INFORMATION).

The system designer can also determine the output voltage of either BUCK1 or BUCK2 through an external feedback resistor ladder by clearing the output voltage selection field in the BUCK1 or BUCK2 control registers.

Figure 67. External Control of Buck Output Voltage through Feedback Resistor Ladder

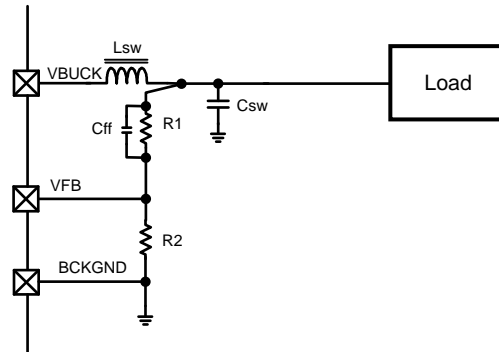

BUCK1, BUCK2 Control Registers and BUCK1EN Pin

BUCK1 and BUCK2 are configurable through I²C accessible registers. Bit fields D4–0 control the output voltage. Bit D5 defines the Modulation mode of the buck, which by default automatically selects PWM or PFM mode depending on the load as described above in the functional description. The modulation mode can be forced to PWM mode regardless of the load by setting bit D5 to a logic 1 in the corresponding buck control register.

Bit D6 controls the enable/disable state of the buck, which is different for BUCK1 and BUCK2 as BUCK1 has an external enable pin: BUCK1_{EN}.

For BUCK1, by default or when D6 is programmed logic 0 in the BUCK1 control register, enable/disable control is passed onto the BUCK1_{EN} pin. A logic 1 applied to this pin enables BUCK1 while a logic 0 disables BUCK1. Setting D6 to 1 in the BUCK1 control register enables BUCK1, regardless of the state of the BUCK1_{EN} pin. If the system designer permanently connects the BUCK1_{EN} pin to GND, then D6 is simply a enable/disable control bit. If the system design permanently connects the enable pin to V_{DD}, then the BUCK1 is enabled during the power-on sequence and will always be on, regardless of the state of bit D6 in the BUCK1 control register (see [Power On/Off Sequencing](#)).

BUCK2 is by default enabled during the power-on sequence and can be enabled/disabled through bit D6 in the BUCK2 control register.

BUCK1 Control Register (05)h

	D7	D6	D5	D4–0	
Access	Read Only 0	R/W			
Data	Reserved	Operation 0: enable/disable determined by state of BUCK1EN pin 1: enable, override BUCK1EN state	Force PWM mode 0: Automatic Modulation Mode 1: Force PWM mode	BUCK1 Output Voltage (V)	
				5'h00	Externally controlled
				5'h01	0.80
				5'h02	0.85
				5'h03	0.90
				5'h04	0.95
				5'h05	1.00
				5'h06	1.05
				5'h07	1.10
				5'h08	1.15
				5'h09	1.20
				5'h0A	1.25
				5'h0B	1.30
				5'h0C	1.35
				5'h0D	1.40
				5'h0E	1.45
				5'h0F	1.50
				5'h10	1.55
				5'h11	1.60
				5'h12	1.65
5'h13	1.70				
5'h14	1.75				
5'h15	1.80				
5'h16	1.85				
5'h17	1.90				
5'h18	1.95				
5'h19–1F	2.00				
Reset	n/a	0	0	5'h09	

BUCK2 Control Register (06)h

	D7	D6	D5	D4–0	
Access	Read Only 0	R/W			
Data	Reserved	Operation 0: disabled 1: enabled	Force PWM mode 0: Automatic Modulation Mode 1: Force PWM mode	BUCK2 Output Voltage (V)	
				5'h00	Externally controlled
				5'h01	1.80
				5'h02	1.90
				5'h03	2.00
				5'h04	2.10
				5'h05	2.20
				5'h06	2.30
				5'h07	2.40
				5'h08	2.50
				5'h09	2.60
				5'h0A	2.70
				5'h0B	2.80
				5'h0C	2.90
				5'h0D	3.00
5'h0E	3.10				
5'h0F	3.20				
5'h1x	3.30				
Reset	n/a	1	0	5'h1F	

BUCK3: Synchronous Magnetic DC/DC Converter

The LP3913 is equipped with a synchronous Buck3 magnetic DC-DC converter to supply power to the Flash memory that has a typical 1.7V-3.3V operating voltage. This voltage is lower than the maximum battery voltage (4.2V typically for Li-polymer cells) and higher than the minimum battery voltage (typically 2.8V). Therefore, in order to provide 3.3V, regardless of the battery voltage, the Buck3 converter efficiently steps down the battery voltage. The Buck3 automatically switches between PWM and PFM modes depending on the load.

By setting bit D6 of the Buck3 control register, the Buck3 will be forced to operate using PWM modulation regardless of the load. By default, this bit is cleared.

Figure 68. Schematic Section for Buck3 Operation

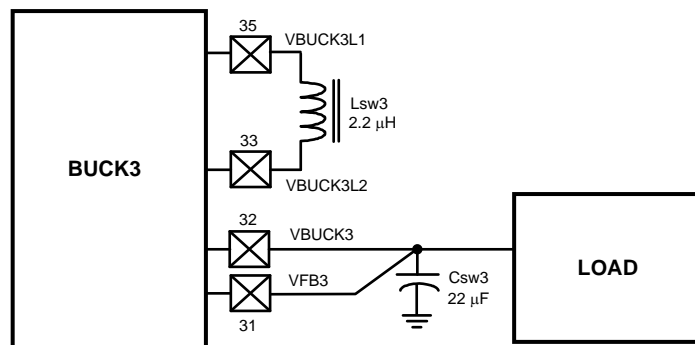

BUCK3 Control Register

Buck3 is controlled through its dedicated control register. Buck3 is enabled through the power-on sequencing. The system processor is required to select the desired Buck3 output voltage through bits D4-0 before enabling it by setting bit D6 in the control register. Buck3 is also disabled when 5'b00000 is programmed in the register field D4-0, regardless of the state of the bit D6. When Buck3 is disabled, its output is internally tied low through a 1MΩ resistor. If D4-0 is set to 5'b00000, the 1MΩ resistor is disconnected.

The default output voltage for the buck can be set to 1.8V, 2.5V, 2.8V, 3.3V, and is factory programmable.

BUCK3 Control Register (07)H

	D7	D6	D5	D4-0	
Access	Read Only 0	R/W			
Data	Reserved	Force PWM 0: Automatic modulation mode 1: Force PWM modulation	Operation 0: disable 1: enable	BUCK3 Output Voltage (V)	
				5'h00	disabled
				5'h01	1.80
				5'h02	1.85
				5'h03	1.90
				5'h04	1.95
				5'h05	2.00
				5'h06	2.05
				5'h07	2.10
				5'h08	2.15
				5'h09	2.20
				5'h0A	2.25
				5'h0B	2.30
				5'h0C	2.35
				5'h0D	2.40
				5'h0E	2.45
				5'h0F	2.50
				5'h10	2.55
				5'h11	2.60
				5'h12	2.65
5'h13	2.70				
5'h14	2.75				
5'h15	2.80				
5'h16	2.85				
5'h17	2.90				
5'h18	2.95				
5'h19	3.00				
5'h1A	3.05				
5'h1B	3.10				
5'h1C	3.15				
5'h1D	3.20				
5'h1E	3.25				
5'h1F	3.30				
Reset	n/a	0	1	5'h1F	

APPLICATIONS INFORMATION

Component Selection

Inductors for BUCK1, BUCK2 and BUCK3

There are two main considerations when choosing an inductor; the inductor should not saturate and the inductor current ripple is small enough to achieve the desired output voltage ripple. Care should be taken when reviewing the different saturation current ratings that are specified by different manufacturers.

Saturation current ratings are typically specified at 25°C, so ratings at maximum ambient temperature of the application should be requested from the manufacturer.

There are two methods to choose the inductor saturation current rating:

Method 1: The saturation current is greater than the sum of the maximum load current and the worst case average to peak inductor current. This can be written as follows:

$$I_{\text{sat}} > I_{\text{outmax}} + I_{\text{ripple}}$$

$$\text{where } I_{\text{ripple}} = \frac{1}{f} * \left(\frac{V_{\text{in}} - V_{\text{out}}}{2L} \right) * \left(\frac{V_{\text{out}}}{V_{\text{in}}} \right)$$

I_{RIPPLE} :	Average to peak inductor current
I_{OUTMAX} :	Maximum load current
V_{IN} :	Maximum input voltage to the buck
L:	Min inductor value including worse case tolerances (30% drop can be considered for method 1)
f:	Minimum switching frequency (1.6 mHz)
V_{OUT} :	Buck Output voltage

Method 2: A more conservative and recommended approach is to choose an inductor that has saturation current rating greater than the maximum current limit of TBA.

Inductor	Value	Unit	Description	Notes
$L_{\text{SW}1,2}$	2.2	μH	BUCK1,2 Inductor	D.C.R. 70 mΩ
$L_{\text{SW}3}$	2.2	μH	BUCK3 Inductor	D.C.R. 70 mΩ

External Capacitors

The regulators on the LP3913 require external capacitors for regulator stability. These are specifically designed for portable applications requiring minimum board space and smallest components. These capacitors must be correctly selected for good performance.

LDO Capacitor Selection

Input Capacitor

An input capacitor is required for stability. It is recommended that a 1.0 μF capacitor be connected between the LDO input pin and ground (this capacitance value may be increased without limit).

This capacitor must be located a distance of not more than 1 cm from the input pin and returned to a clean analog ground. Any good quality ceramic, tantalum, or film capacitor may be used at the input.

Important: Tantalum capacitors can suffer catastrophic failures due to surge currents when connected to a low impedance source of power (like a battery or a very large capacitor). If a tantalum capacitor is used at the input, it must be specified by the manufacturer to have a surge current rating sufficient for the application.

There are no requirements for the ESR (Equivalent Series Resistance) on the input capacitor, but tolerance and temperature coefficient must be considered when selecting the capacitor to ensure the capacitance will remain approximately 1.0 μF over the entire operating temperature range.

Output Capacitor

The LDOs on the LP3913 are designed specifically to work with very small ceramic output capacitors. A 1.0 μF ceramic capacitor (temperature types Z5U, Y5V or X7R) with ESR between 5 m Ω to 500 m Ω , are suitable in the application circuit.

It is also possible to use tantalum or film capacitors at the device output, C_{OUT} (or V_{OUT}), but these are not as attractive for reasons of size and cost.

The output capacitor must meet the requirement for the minimum value of capacitance and also have an ESR value that is within the range 5 m Ω to 500 m Ω for stability.

Capacitor Characteristics

The LDOs are designed to work with ceramic capacitors on the output to take advantage of the benefits they offer. For capacitance values in the range of 0.47 μF to 4.7 μF , ceramic capacitors are the smallest, least expensive and have the lowest ESR values, thus making them best for eliminating high frequency noise. The ESR of a typical 1.0 μF ceramic capacitor is in the range of 20 m Ω to 40 m Ω , which easily meets the ESR requirement for stability for the LDO's.

For both input and output capacitors, careful interpretation of the capacitor specification is required to ensure correct device operation. The capacitor value can change greatly, depending on the operating conditions and capacitor type.

In particular, the output capacitor selection should take account of all the capacitor parameters, to ensure that the specification is met within the application. The capacitance can vary with DC bias conditions as well as temperature and frequency of operation. Capacitor values will also show some decrease over time due to aging. The capacitor parameters are also dependent on the particular case size, with smaller sizes giving poorer performance figures in general. As an example, the graph below shows a typical graph comparing different capacitor case sizes in a Capacitance vs. DC Bias plot.

Figure 69. Graph Showing a Typical Variation in Capacitance vs. DC Bias

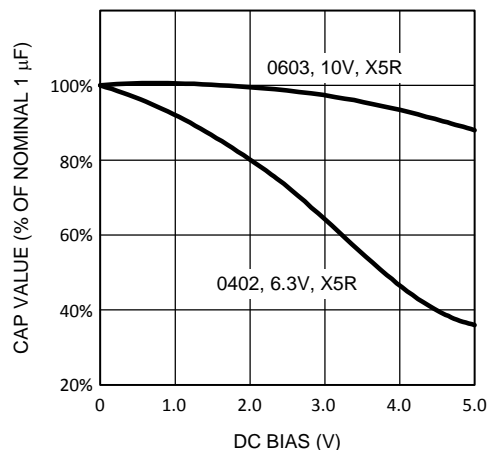

As shown in the graph, increasing the DC Bias condition can result in the capacitance value that falls below the minimum value given in the recommended capacitor specifications table. Note that the graph shows the capacitance out of spec for the 0402 case size capacitor at higher bias voltages. It is therefore recommended that the capacitor manufacturers' specifications for the nominal value capacitor are consulted for all conditions, as some capacitor sizes (e.g. 0402) may not be suitable in the actual application.

The ceramic capacitor's capacitance can vary with temperature. The capacitor type X7R, which operates over a temperature range of -55°C to $+125^{\circ}\text{C}$, will only vary the capacitance to within $\pm 15\%$. The capacitor type X5R has a similar tolerance over a reduced temperature range of -55°C to $+85^{\circ}\text{C}$. Many large value ceramic capacitors, larger than $1\ \mu\text{F}$ are manufactured with Z5U or Y5V temperature characteristics. Their capacitance can drop by more than 50% as the temperature varies from 25°C to 85°C . Therefore X7R is recommended over Z5U and Y5V in applications where the ambient temperature will change significantly above or below 25°C .

Tantalum capacitors are less desirable than ceramic for use as output capacitors because they are more expensive when comparing equivalent capacitance and voltage ratings in the $0.47\ \mu\text{F}$ to $4.7\ \mu\text{F}$ range.

Another important consideration is that tantalum capacitors have higher ESR values than equivalent size ceramics. This means that while it may be possible to find a tantalum capacitor with an ESR value within the stable range, it would have to be larger in capacitance (which means bigger and more costly) than a ceramic capacitor with the same ESR value. It should also be noted that the ESR of a typical tantalum will increase about 2:1 as the temperature goes from $+25^{\circ}\text{C}$ down to -40°C , so some guard band must be allowed.

Noise Bypass Capacitors for V_{REFH} Pin

Connecting respectively $100\ \text{nF}$ and $1\ \text{nF}$ grounded bypass capacitors to the V_{REFH} pin significantly reduces noise on the LDO outputs. V_{REFH} is a high impedance nodes connected to a bandgap reference used for the LDOs. Any significant loading on this node will cause a change on the regulated output voltages. For this reason, DC leakage current through these pins must be kept as low as possible for best output voltage accuracy. The types of capacitors best suited for the noise bypass capacitors are ceramic and film capacitors. High-quality ceramic capacitors with either NPI or COG dielectric typically have very low leakage. Polypropylene and polycarbonate film capacitors are available in small surface-mount packages and typically have extremely low leakage current. **Residual solder flux** is another potential source of leakage, which mandates thorough cleaning of the assembled PCBs.

Input Capacitor Selection for BUCK1, BUCK2 and BUCK3

A ceramic input capacitor of $10\ \mu\text{F}$, 6.3V is sufficient for the magnetic DC/DC converters. Place the input capacitor as close as possible to the input of the device. A large value may be used for improved input voltage filtering. The recommended capacitor types are X7R or X5R. Y5V type capacitors should not be used. DC bias characteristics of ceramic capacitors must be considered when selecting case sizes like 0805 and 0603. The input filter capacitor supplies current to the PFET switch of the DC/DC converter in the first half of each cycle and reduces voltage ripple imposed on the input power source. A ceramic capacitor's low ESR (Equivalent Series Resistance) provides the best noise filtering of the input voltage spikes due to fast current transients. A capacitor with sufficient ripple current rating should be selected. The Input current ripple can be calculated as:

$$I_{\text{rms}} = I_{\text{outmax}} \sqrt{\frac{V_{\text{in}}}{V_{\text{out}}} \left(1 - \frac{V_{\text{in}}}{V_{\text{out}}} + \frac{r^2}{12} \right)}$$

$$\text{where } r = \frac{(V_{\text{in}} - V_{\text{out}}) * V_{\text{out}}}{L * f * I_{\text{outmax}} * V_{\text{in}}}$$

The worse case is when $V_{\text{IN}} = 2V_{\text{OUT}}$

Output Capacitor Selection for BUCK1, BUCK2 and BUCK3

A $10\ \mu\text{F}$, 6.3V ceramic capacitor should be used on the output of the BUCK1 and BUCK2 magnetic DC/DC converters. BUCK3 needs a $22\ \mu\text{F}$ capacitor. The output capacitor needs to be mounted as close as possible to the output of the device. A large value may be used for improved input voltage filtering. The recommended capacitor types are X7R or X5R. Y5V type capacitors should not be used. DC bias characteristics of ceramic capacitors must be considered when selecting case sizes like 0805 and 0603. DC bias characteristics vary from manufacturer to manufacturer and DC bias curves should be requested from them and analyzed as part of the capacitor selection process.

The output filter capacitor of the magnetic DC/DC converter smooths out current flow from the inductor to the load, helps maintain a steady output voltage during transient load changes and reduces output voltage ripple. These capacitors must be selected with sufficient capacitance and sufficiently low ESR to perform these functions.

The output voltage ripple is caused by the charging and the discharging of the output capacitor and also due to its ESR and can be calculated as follows:

$$V_{pp-c} = \frac{I_{ripple}}{4 * f * C}$$

Voltage peak-to-peak ripple due to ESR can be expressed as follows:

$$V_{PP-ESR} = 2 * I_{RIPPLE} * R_{ESR} \quad (6)$$

Because the V_{PP-C} and V_{PP-ESR} are out of phase, the RMS value can be used to get an approximate value of the peak-to-peak ripple:

$$V_{pp-rms}^2 = \sqrt{V_{pp-c}^2 + V_{pp-esr}^2}$$

Note that the output voltage ripple is dependent on the inductor current ripple and the equivalent series resistance of the output capacitor (R_{ESR}). The R_{ESR} is frequency dependent as well as temperature dependent. The R_{ESR} should be calculated with the applicable switching frequency and ambient temperature.

Capacitor	Min Value	Unit	Description	Recommended Type
C _{VDD}	4.7	μF	Charger Input Capacitor	Ceramic, 6.3V, X5R
C _{CHG_DET}	4.7	μF	Charger Input Capacitor	Ceramic, 6.3V, X5R
C _{USB}	4.7	μF	USB Power (V _{BUS}) Capacitor	Ceramic, 6.3V, X5R
C _{BATT}	4.7	μF	Li-ion Battery Capacitor	Ceramic, 6.3V, X5R
C _{LDO1}	1.0	μF	LDO Output Capacitor	Ceramic, 6.3V, X5R
C _{LDO2}	1.0	μF	LDO Output Capacitor	Ceramic, 6.3V, X5R
C _{VREFH}	0.1	μF	Bypass Capacitor for Internal Voltage Reference	Ceramic, PolyPropylene and Polycarbonate Film
C _{VIN2,3}	10	μF	Buck1, Buck2 Input Capacitor	Ceramic, 6.3V, X5R
CVBUCK1,2	10	μF	BUCK1,2 Output Capacitor	Ceramic, 6.3V, X5R
C _{SW3}	22	μF	BUCK3 Output Capacitor	Ceramic, 6.3V, X5R
C _{VIN1}	1	μF	LDO Bypass Capacitor	Ceramic, 6.3V, X5R
C _{VIN4}	10	μF	Buck Bypass Capacitor	Ceramic, 6.3V, X5R

Schottky Diode on Charger Input CHG_IN

A Schottky diode is required in the external adapter path to block the reverse current from either the USB or the battery source. The most critical parameter in the selection of the right Schottky diode is the leakage current, which needs to be below 10 μA over the temperature range in order to prevent false detection of the presence of an external adapter. In addition the Schottky diode should have a maximum voltage rating of 10V or higher. The current rating depends on the current limit of the adapter. The forward voltage should be limited to 500 mV at its maximum current. The recommended Schottky diode is MBRA210ET3 from ON Semiconductor which has a reverse leakage current under 1 μA at room temperature and a forward voltage drop of 500 mV at their max rated current $I_F = 2A$.

Resistors

Battery Thermistor

The LP3913 battery thermistor bias provided by the T_S pin is tailored to thermistors with the following specification:

- Negative Temperature Coefficient
- 100 k Ω resistance

A suitable solution is available from AVX thermistors:

AVXNB21250104 <http://www.avxcorp.com/docs/Catalogs/nb21-23.pdf>

I²C Pullup Resistors

I²C_SDA, I²C_SCL terminals need to have pullup resistors connected to the V_{DDIO} pin. V_{DDIO} must be connected to a power supply that is less than or equal to V_{DD} , such as Buck2. The values of the pull-up resistors (typ. ≈ 1.8 k Ω) are determined by the capacitance of the bus. Too large of a resistor combined with a given bus capacitance will result in a rise time that would violate the max rise time specification. Too small of a resistor will result in a contention with the pull-down transistor on either slave(s) or master.

R_{REF} Resistor

The current through this resistor is used as a reference current that biases many analog circuits inside the LP3913 and needs to have a resistance of 121 k Ω $\pm 1\%$

R_{SENSE} Resistor

The current through this resistor is used as a reference current for the charge current. The accuracy of the ADC is dependent on the tolerance of this resistor. R_{SENSE} needs to have a resistance of 4.64 k Ω $\pm 1\%$ tolerance.

Operation without I²C Interface

Operation of the LP3913 without the I²C interface is possible if the system can operate with default values for the DC/DC converters and the charger. (Read below: Factory programmable options). The I²C-less system must use the POWERACK pin to power cycle the LP3913.

I²C Master Power Concern

The processor that contains the I²C master should be powered by BUCK1 or LDO2 as these converters require no I²C access to enable/disable them. If the I²C master were to be powered by a DC/DC converter that is enable/disable through a control register, then a corrupted application software execution could by accident disable the power to the I²C master, which in this case has no means to recover. It is possible that the regulator connected to V_{DDIO} could accidentally disable, in which case the processor should be able to recognize that communication has been broken and then power down the system to allow for a clean restart.

System Operation When the Load Current Exceeds the USB or Adapter Current Limit

In the event that the system requires current that exceeds the current limit of either the USB or the adapter source, then the battery can provide the extra power provided that it has been charged. It is clear that a long sustained overload will eventually discharge the battery such that its extra power will no longer be sufficient to properly operate the system. This will be the case when the system is for instance operated from a USB host with a 100 mA current limit.

Factory Programmable Options

The following options are programmed for the LP3913. The system designer that needs specific options is advised to contact the local TI sales office.

Factory programmable options	Default Value
LDO1 output voltage after power up	2.0V
LDO2 output voltage after power up	3.3V
BUCK1 output voltage after power up	1.2V
BUCK2 output voltage after power up	3.3V
BUCK3 power voltage after power up	3.3V
Battery low threshold	2.90V
Delay for LDO1 and LDO2	5 ms
Delay for Buck1	15 ms
Delay for Buck2	20 ms
Delay for Buck3	25 ms
Delay for NRST	60 ms
Default Full Rate Charge Current	100 mA
EOC Default	0.1C
V _{TERM} Default	4.2V
ONOFF Edge/Level	Level
ONOFF Polarity	Positive
Buck1 Enable Polarity	Positive
LDO2 Enable Polarity	Positive
Ignore Ten Hour Timer	No
LED default current	10 mA
Buck3 500 mA output current	Yes
Thermistor 10k/100k	100k

The I²C Chip ID address is offered as a metal mask option. The current value equals 60 hex.

PCB Layout Considerations

For good performance of the circuit, it is essential to place the input and output capacitors very close to the circuit and use wide routing for the traces allowing high currents.

Sensitive components should be placed far from those components with high pulsating current.

Decoupling capacitors should be close to circuit's V_{IN} pins. Digital and analog ground should be routed separately and connected together in a star connection.

It's good practice to minimize high current and switching current paths.

LDO Regulators

Place the filter capacitors very close to the input and output pins. Use large trace width for high current carrying traces and the returns to ground.

BUCK Regulators

Place the supply bypass, filter capacitor and inductor close together and keep the traces short. The traces between these components carry relatively high switching current and act as antennas. Following these rules reduces radiated noise.

Arrange the components so that the switching current loops curl in the same direction.

Connect the buck ground and the ground of the capacitors together using generous component-side copper fill as a pseudo-ground plane. Then connect this back to the general board system ground plane at a single point. Place the pseudo-ground plane below these components and then have it tied to system ground of the output capacitor outside of the current loops. This prevents the switched current from injecting noise into the system ground. These components along with the inductor and output should be placed on the same side of the circuit board, and their connections should be made on the same layer.

Route the noise sensitive traces such as the voltage feedback path away from the inductor. This is done by routing it on the bottom layer or by adding a grounded copper area between switching node and feedback path. Noisy traces between the power components and keep any digital lines away from this section. Keep the feedback node as small as possible so that the ground pin and ground traces will shield it from the SW or buck output.

Use wide traces between the power components and for power connections to the DC-DC converter circuit. This reduces voltage errors caused by resistive losses.

Thermal Performance of the WQFN Package

The LP3913 is a monolithic device with integrated power FETs. For that reason, it is important to pay special attention to the thermal impedance of the WQFN package and to the PCB layout rules in order to maximize power dissipation of the WQFN package.

The WQFN package is designed for enhanced thermal performance and features an exposed die attach pad at the bottom center of the package that creates a direct path to the PCB for maximum power dissipation. Compared to the traditional leaded packages where the die attach pad is embedded inside the molding compound, the WQFN reduces one layer in the thermal path.

The thermal advantage of the WQFN package is fully realized only when the exposed die attach pad is soldered down to a thermal land on the PCB board with thermal vias planted underneath the thermal land. Based on thermal analysis of the WQFN package, the junction-to-ambient thermal resistance (θ_{JA}) can be improved by a factor of two when the die attach pad of the WQFN package is soldered directly onto the PCB with thermal land and thermal vias, as opposed to an alternative with no direct soldering to a thermal land. Typical pitch and outer diameter for thermal vias are 1.27 mm and 0.33 mm, respectively. Typical copper via barrel plating is 1 oz., although thicker copper may be used to further improve thermal performance. The LP3913 die attach pad is connected to the substrate of the IC and therefore, the thermal land and vias on the PCB board need to be connected to ground (GND pin).

For more information on board layout techniques, refer to Application Note AN-1187 Leadless Leadframe Package (LLP) ([SNOA401](#)).

This application note also discusses package handling, solder stencil, and the assembly process.

REVISION HISTORY

Changes from Revision H (May 2013) to Revision I	Page
• Changed layout of National Data Sheet to TI format	63

PACKAGING INFORMATION

Orderable Device	Status (1)	Package Type	Package Drawing	Pins	Package Qty	Eco Plan (2)	Lead/Ball Finish (6)	MSL Peak Temp (3)	Op Temp (°C)	Device Marking (4/5)	Samples
LP3913SQ-AA/NOPB	NRND	WQFN	NJV	48	250	Green (RoHS & no Sb/Br)	CU SN	Level-1-260C-UNLIM	-40 to 85	L3913-AA	
LP3913SQ-AC/NOPB	NRND	WQFN	NJV	48	250	Green (RoHS & no Sb/Br)	CU SN	Level-1-260C-UNLIM		L3913-AC	
LP3913SQ-AE/NOPB	NRND	WQFN	NJV	48	250	Green (RoHS & no Sb/Br)	CU SN	Level-1-260C-UNLIM		L3913-AE	
LP3913SQ-AR/NOPB	NRND	WQFN	NJV	48	250	Green (RoHS & no Sb/Br)	CU SN	Level-1-260C-UNLIM		L3913-AR	
LP3913SQX-AA/NOPB	NRND	WQFN	NJV	48	2500	Green (RoHS & no Sb/Br)	CU SN	Level-1-260C-UNLIM	-40 to 85	L3913-AA	

(1) The marketing status values are defined as follows:

ACTIVE: Product device recommended for new designs.

LIFEBUY: TI has announced that the device will be discontinued, and a lifetime-buy period is in effect.

NRND: Not recommended for new designs. Device is in production to support existing customers, but TI does not recommend using this part in a new design.

PREVIEW: Device has been announced but is not in production. Samples may or may not be available.

OBSOLETE: TI has discontinued the production of the device.

(2) **RoHS:** TI defines "RoHS" to mean semiconductor products that are compliant with the current EU RoHS requirements for all 10 RoHS substances, including the requirement that RoHS substance do not exceed 0.1% by weight in homogeneous materials. Where designed to be soldered at high temperatures, "RoHS" products are suitable for use in specified lead-free processes. TI may reference these types of products as "Pb-Free".

RoHS Exempt: TI defines "RoHS Exempt" to mean products that contain lead but are compliant with EU RoHS pursuant to a specific EU RoHS exemption.

Green: TI defines "Green" to mean the content of Chlorine (Cl) and Bromine (Br) based flame retardants meet JS709B low halogen requirements of <=1000ppm threshold. Antimony trioxide based flame retardants must also meet the <=1000ppm threshold requirement.

(3) MSL, Peak Temp. - The Moisture Sensitivity Level rating according to the JEDEC industry standard classifications, and peak solder temperature.

(4) There may be additional marking, which relates to the logo, the lot trace code information, or the environmental category on the device.

(5) Multiple Device Markings will be inside parentheses. Only one Device Marking contained in parentheses and separated by a "-" will appear on a device. If a line is indented then it is a continuation of the previous line and the two combined represent the entire Device Marking for that device.

(6) Lead/Ball Finish - Orderable Devices may have multiple material finish options. Finish options are separated by a vertical ruled line. Lead/Ball Finish values may wrap to two lines if the finish value exceeds the maximum column width.

Important Information and Disclaimer: The information provided on this page represents TI's knowledge and belief as of the date that it is provided. TI bases its knowledge and belief on information provided by third parties, and makes no representation or warranty as to the accuracy of such information. Efforts are underway to better integrate information from third parties. TI has taken and continues to take reasonable steps to provide representative and accurate information but may not have conducted destructive testing or chemical analysis on incoming materials and chemicals. TI and TI suppliers consider certain information to be proprietary, and thus CAS numbers and other limited information may not be available for release.

In no event shall TI's liability arising out of such information exceed the total purchase price of the TI part(s) at issue in this document sold by TI to Customer on an annual basis.

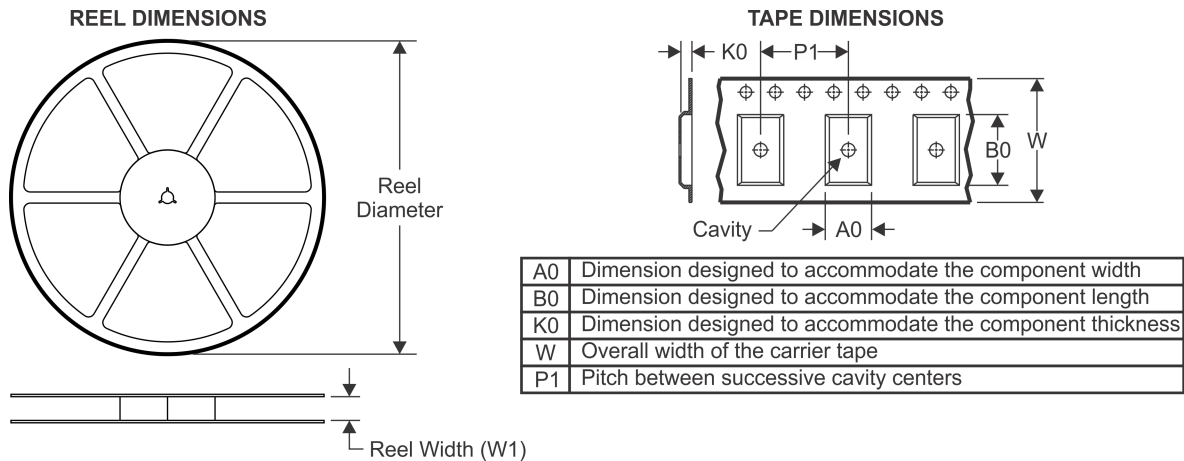
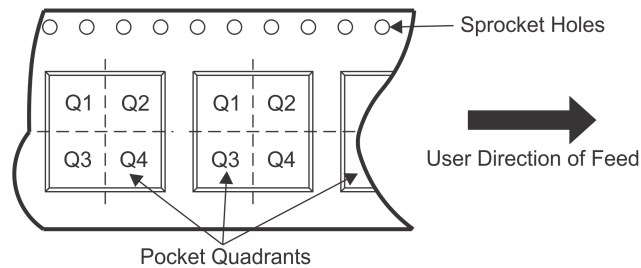
TAPE AND REEL INFORMATION

QUADRANT ASSIGNMENTS FOR PIN 1 ORIENTATION IN TAPE

*All dimensions are nominal

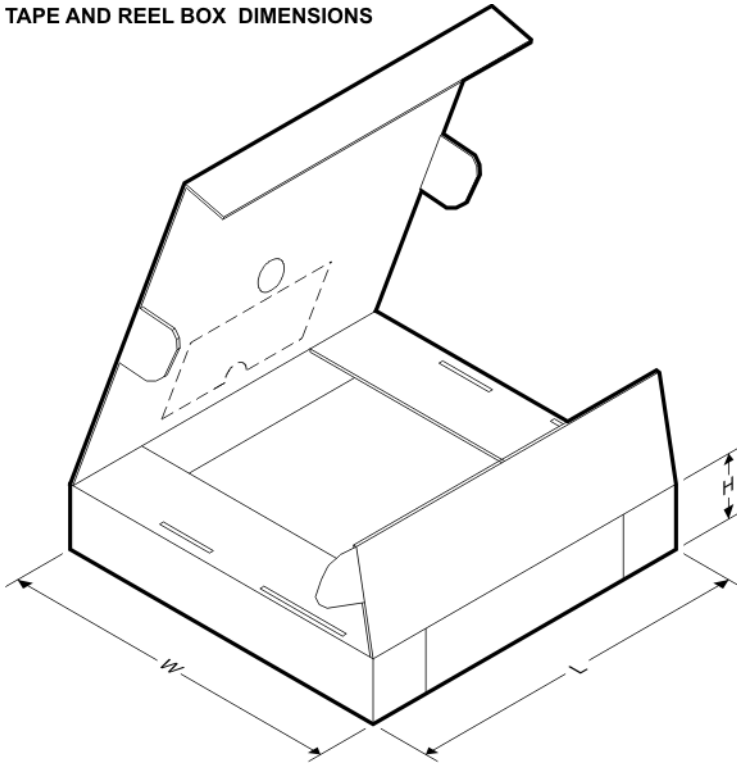
Device	Package Type	Package Drawing	Pins	SPQ	Reel Diameter (mm)	Reel Width W1 (mm)	A0 (mm)	B0 (mm)	K0 (mm)	P1 (mm)	W (mm)	Pin1 Quadrant
LP3913SQ-AA/NOPB	WQFN	NJV	48	250	178.0	16.4	6.3	6.3	1.5	12.0	16.0	Q1
LP3913SQ-AC/NOPB	WQFN	NJV	48	250	178.0	16.4	6.3	6.3	1.5	12.0	16.0	Q1
LP3913SQ-AE/NOPB	WQFN	NJV	48	250	178.0	16.4	6.3	6.3	1.5	12.0	16.0	Q1
LP3913SQ-AR/NOPB	WQFN	NJV	48	250	178.0	16.4	6.3	6.3	1.5	12.0	16.0	Q1
LP3913SQX-AA/NOPB	WQFN	NJV	48	2500	330.0	16.4	6.3	6.3	1.5	12.0	16.0	Q1

TAPE AND REEL BOX DIMENSIONS

*All dimensions are nominal

Device	Package Type	Package Drawing	Pins	SPQ	Length (mm)	Width (mm)	Height (mm)
LP3913SQ-AA/NOPB	WQFN	NJV	48	250	210.0	185.0	35.0
LP3913SQ-AC/NOPB	WQFN	NJV	48	250	210.0	185.0	35.0
LP3913SQ-AE/NOPB	WQFN	NJV	48	250	210.0	185.0	35.0
LP3913SQ-AR/NOPB	WQFN	NJV	48	250	210.0	185.0	35.0
LP3913SQX-AA/NOPB	WQFN	NJV	48	2500	367.0	367.0	35.0

NJV0048A

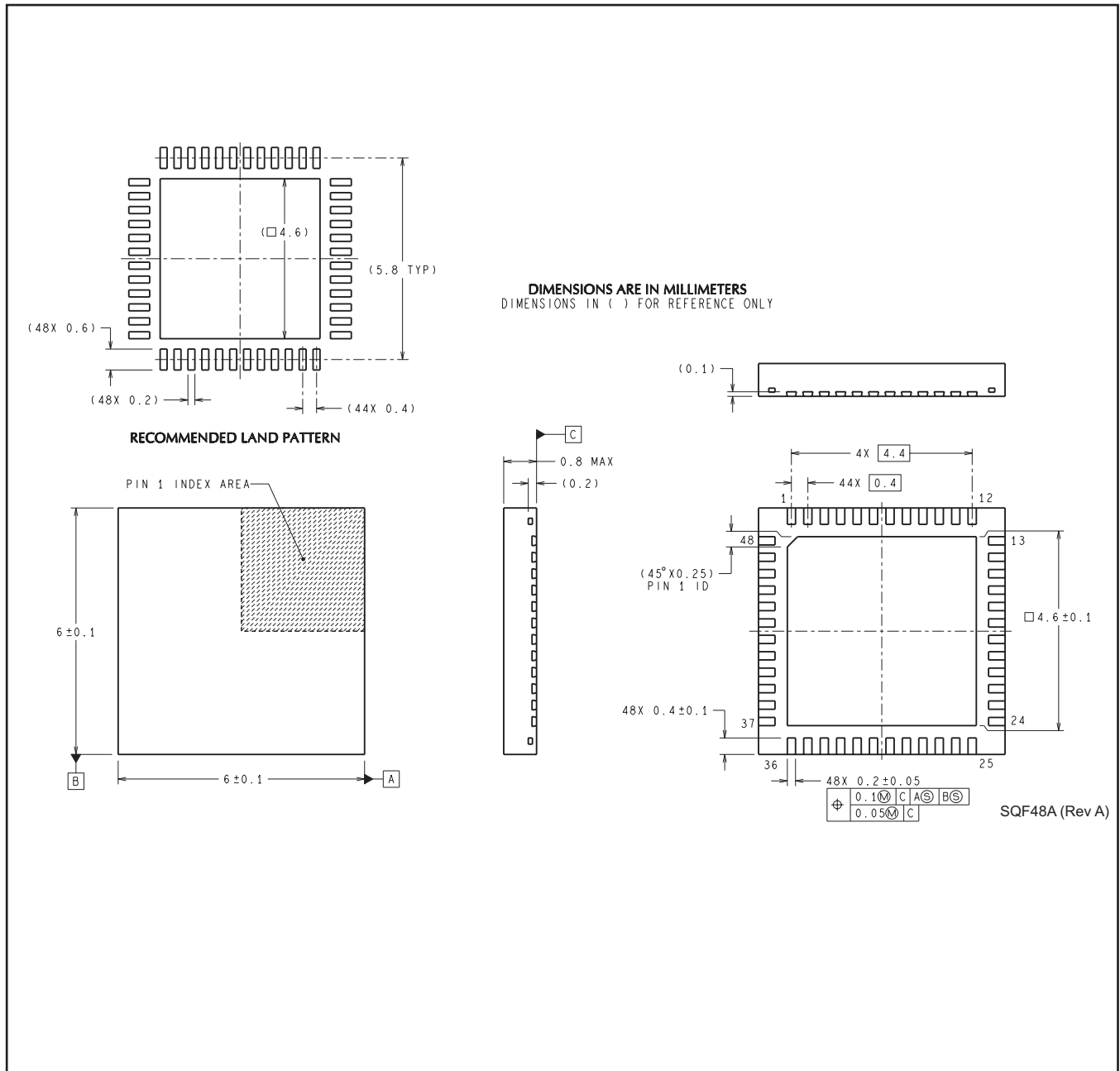

IMPORTANT NOTICE

Texas Instruments Incorporated (TI) reserves the right to make corrections, enhancements, improvements and other changes to its semiconductor products and services per JESD46, latest issue, and to discontinue any product or service per JESD48, latest issue. Buyers should obtain the latest relevant information before placing orders and should verify that such information is current and complete.

TI's published terms of sale for semiconductor products (<http://www.ti.com/sc/docs/stdterms.htm>) apply to the sale of packaged integrated circuit products that TI has qualified and released to market. Additional terms may apply to the use or sale of other types of TI products and services.

Reproduction of significant portions of TI information in TI data sheets is permissible only if reproduction is without alteration and is accompanied by all associated warranties, conditions, limitations, and notices. TI is not responsible or liable for such reproduced documentation. Information of third parties may be subject to additional restrictions. Resale of TI products or services with statements different from or beyond the parameters stated by TI for that product or service voids all express and any implied warranties for the associated TI product or service and is an unfair and deceptive business practice. TI is not responsible or liable for any such statements.

Buyers and others who are developing systems that incorporate TI products (collectively, "Designers") understand and agree that Designers remain responsible for using their independent analysis, evaluation and judgment in designing their applications and that Designers have full and exclusive responsibility to assure the safety of Designers' applications and compliance of their applications (and of all TI products used in or for Designers' applications) with all applicable regulations, laws and other applicable requirements. Designer represents that, with respect to their applications, Designer has all the necessary expertise to create and implement safeguards that (1) anticipate dangerous consequences of failures, (2) monitor failures and their consequences, and (3) lessen the likelihood of failures that might cause harm and take appropriate actions. Designer agrees that prior to using or distributing any applications that include TI products, Designer will thoroughly test such applications and the functionality of such TI products as used in such applications.

TI's provision of technical, application or other design advice, quality characterization, reliability data or other services or information, including, but not limited to, reference designs and materials relating to evaluation modules, (collectively, "TI Resources") are intended to assist designers who are developing applications that incorporate TI products; by downloading, accessing or using TI Resources in any way, Designer (individually or, if Designer is acting on behalf of a company, Designer's company) agrees to use any particular TI Resource solely for this purpose and subject to the terms of this Notice.

TI's provision of TI Resources does not expand or otherwise alter TI's applicable published warranties or warranty disclaimers for TI products, and no additional obligations or liabilities arise from TI providing such TI Resources. TI reserves the right to make corrections, enhancements, improvements and other changes to its TI Resources. TI has not conducted any testing other than that specifically described in the published documentation for a particular TI Resource.

Designer is authorized to use, copy and modify any individual TI Resource only in connection with the development of applications that include the TI product(s) identified in such TI Resource. NO OTHER LICENSE, EXPRESS OR IMPLIED, BY ESTOPPEL OR OTHERWISE TO ANY OTHER TI INTELLECTUAL PROPERTY RIGHT, AND NO LICENSE TO ANY TECHNOLOGY OR INTELLECTUAL PROPERTY RIGHT OF TI OR ANY THIRD PARTY IS GRANTED HEREIN, including but not limited to any patent right, copyright, mask work right, or other intellectual property right relating to any combination, machine, or process in which TI products or services are used. Information regarding or referencing third-party products or services does not constitute a license to use such products or services, or a warranty or endorsement thereof. Use of TI Resources may require a license from a third party under the patents or other intellectual property of the third party, or a license from TI under the patents or other intellectual property of TI.

TI RESOURCES ARE PROVIDED "AS IS" AND WITH ALL FAULTS. TI DISCLAIMS ALL OTHER WARRANTIES OR REPRESENTATIONS, EXPRESS OR IMPLIED, REGARDING RESOURCES OR USE THEREOF, INCLUDING BUT NOT LIMITED TO ACCURACY OR COMPLETENESS, TITLE, ANY EPIDEMIC FAILURE WARRANTY AND ANY IMPLIED WARRANTIES OF MERCHANTABILITY, FITNESS FOR A PARTICULAR PURPOSE, AND NON-INFRINGEMENT OF ANY THIRD PARTY INTELLECTUAL PROPERTY RIGHTS. TI SHALL NOT BE LIABLE FOR AND SHALL NOT DEFEND OR INDEMNIFY DESIGNER AGAINST ANY CLAIM, INCLUDING BUT NOT LIMITED TO ANY INFRINGEMENT CLAIM THAT RELATES TO OR IS BASED ON ANY COMBINATION OF PRODUCTS EVEN IF DESCRIBED IN TI RESOURCES OR OTHERWISE. IN NO EVENT SHALL TI BE LIABLE FOR ANY ACTUAL, DIRECT, SPECIAL, COLLATERAL, INDIRECT, PUNITIVE, INCIDENTAL, CONSEQUENTIAL OR EXEMPLARY DAMAGES IN CONNECTION WITH OR ARISING OUT OF TI RESOURCES OR USE THEREOF, AND REGARDLESS OF WHETHER TI HAS BEEN ADVISED OF THE POSSIBILITY OF SUCH DAMAGES.

Unless TI has explicitly designated an individual product as meeting the requirements of a particular industry standard (e.g., ISO/TS 16949 and ISO 26262), TI is not responsible for any failure to meet such industry standard requirements.

Where TI specifically promotes products as facilitating functional safety or as compliant with industry functional safety standards, such products are intended to help enable customers to design and create their own applications that meet applicable functional safety standards and requirements. Using products in an application does not by itself establish any safety features in the application. Designers must ensure compliance with safety-related requirements and standards applicable to their applications. Designer may not use any TI products in life-critical medical equipment unless authorized officers of the parties have executed a special contract specifically governing such use. Life-critical medical equipment is medical equipment where failure of such equipment would cause serious bodily injury or death (e.g., life support, pacemakers, defibrillators, heart pumps, neurostimulators, and implantables). Such equipment includes, without limitation, all medical devices identified by the U.S. Food and Drug Administration as Class III devices and equivalent classifications outside the U.S.

TI may expressly designate certain products as completing a particular qualification (e.g., Q100, Military Grade, or Enhanced Product). Designers agree that it has the necessary expertise to select the product with the appropriate qualification designation for their applications and that proper product selection is at Designers' own risk. Designers are solely responsible for compliance with all legal and regulatory requirements in connection with such selection.

Designer will fully indemnify TI and its representatives against any damages, costs, losses, and/or liabilities arising out of Designer's non-compliance with the terms and provisions of this Notice.



Looking for pricing, stock, or lifecycle information?

Click below to explore more details on WIN SOURCE:

 [View LP3913SQ-AE/NOPB on WIN SOURCE](#)

 [Texas Instruments](#) Information

Optimize Your Supply Chain with WIN SOURCE Solutions

-  Global Sourcing Solution
-  Obsolete Management
-  Cost Control Management
-  Shortage Management
-  Alternative Solution
-  Excess Inventory Management