



**THE DATASHEET OF  
LR36689U**



# SHARP

Integrated Circuit  
Catalog

# Integrated Circuits 2006

■ CMOS Image Sensors / CCDs ■ LSIs for LCDs ■ System LSIs ■ Smart Card Systems  
■ Flash Memories / Combination Memories ■ Power Devices / Analog ICs ■ Packages



# Guide to SHARP Semiconductors

## 1. Semiconductor Documents

See the following documents to obtain information on SHARP devices.  
(Confirm the latest device specification sheets before using any SHARP device.)

IC information brochure	SILICON
Catalogs	CCDs/CMOS Image Sensors LSIs for LCDs Analog ICs

## 2. SHARP Home Page

For information on SHARP's latest products, see the following URL :  
<http://sharp-world.com/products/device/index.html>

### Contents

- Data sheets
- Catalog
- New Product Information
- SHARP's devices for the future

NOTE : Package Descriptions  
In this catalog, model numbers and corresponding package descriptions are shortened as shown below :

Example

Model No.	Package		Model No.	Package
IR3C08	P-SDIP024-0300	⇒	IR3C08/N	P-SDIP024-0300/ P-SOP024-0450
IR3C08N	P-SOP024-0450			(Short form)

ARM, ARM7TDMI, ARM720T, ARM922T, ARM946E-S, ARM926EJ-S, Multi-ICE, RealView and Developer Suite are trademarks of ARM Ltd.  
MULTI, Slingshot and probe are trademarks of Green Hills Software Inc.  
EWARM is a trademark of IAR Systems Inc.  
BDI 2000 is a trademark of Abatron Inc.  
Vitra, Genia, Opella and Pathfinder are trademarks of Ashling Microsystems Ltd.  
JTAgjet-ARM is a trademark of Signum Systems Corporation.  
TRACE32 is a trademark of Lauterbach Inc.  
EMUL-ARM is a trademark of Nohau a DBA of Knowit LLC.  
MAJIC and JEENI are trademarks of Embedded Performance Inc.  
Zoom is a trademark of Logic Product Development Inc.  
Windows is a trademark of Microsoft Corporation.  
ThreadX is a trademark of Express Logic Inc.  
Nucleus+ is a trademark of Accelerated Technologies Inc.  
VxWorks is a trademark of Wind River Systems Inc.  
Ball Grid Array and BGA are trademarks of Motorola Nippon Ltd.  
RSDS is a trademark of National Semiconductor Corporation.  
Java and Java Card are trademarks of Sun Microsystems, Inc.  
SmartMedia is a trademark of Toshiba Corporation.  
Z80 is a trademark of ZiLOG, Inc.  
CompactFlash is a trademark of SanDisk Corporation.  
Linux is a trademark of Linus Torvalds.  
MIPS, MIPS32, 4KSd are trademarks of MIPS Technologies, Inc.  
Ethernet is a trademark of Xerox Corporation.  
QUALCOMM and MSM are trademarks of QUALCOMM Incorporated.  
All other product or company names are trademarks of their respective holders.

# CONTENTS

## CMOS Image Sensors/CCDs 2

### CMOS Camera Modules

- CMOS Camera Modules -----3

### CCD Camera Modules

- CCD Camera Modules -----4
- Peripheral LSI for CCD Camera Modules -----4
- Power Supply ICs for CCD Camera Modules -----4

### CCDs and Peripheral ICs/LSIs

- Higher-resolution CCDs -----5
- 1/3-type CCDs -----5
- 1/4-type CCDs -----5
- 1/3-type CCDs with Dual-power-supply (5 V/12 V) Operation --5
- CCD Peripheral ICs/LSIs -----6

## LSIs for LCDs 11

### For Notebook PCs, PC Monitors and LCD TVs

- TFT-LCD Drivers -----12

### For Mobile Equipment

- TFT-LCD Drivers -----13
- STN-LCD Drivers -----13
- Power Supply IC for STN-LCD Drivers -----13

### For Cellular Phones

- TFT-LCD Controller/Driver with Two-chip Configuration ---14
- Single-chip TFT-LCD Controller/Driver -----14
- TFT-LCD Controllers -----14
- TFT-LCD Driver -----14
- Color STN-LCD Controllers/Drivers -----15
- Color STN-LCD Controller -----15

### Peripheral ICs for LSIs for LCDs

- Video Interface ICs for TFT-LCDs -----16
- Power Supply ICs for TFT-LCDs -----16
- Gray-scale ICs for TFT-LCDs -----16

## System LSIs 17

### Special-function LSIs -----18

### ARM RISC Core LSIs

- ARM RISC Core ASSPs for Mobile Equipment -----19
- Startup Kit for ARM Embedded Linux™ -----19
- Development Environment for ARM Microprocessors -----19
- ARM Universal Microcontroller -----20
- Development Environment for ARM Microprocessors -----21

### IPs

- CPU Cores/Peripherals/Analog Cells/Analog PLL/Others --22

## Smart Card Systems 23

### Smart Card Systems

- Smart Cards/LSI Modules for Smart Cards -----24
- Reader/Writer for Smart Cards -----25
- SDK (Software Development Kit) for Smart Cards -----25

## Flash Memories/Combination Memories 26

### Flash Memory Product Overview -----27 (Product Lineup)

### Highly Functional Flash Memories

- Boot Block Type 3 V Page Mode Flash Memories -----29

### Standard Flash Memories

- Boot Block Type 3 V Flash Memories -----29

### System-Flash

- FWH Interface System-Flash for PCs -----30
- Fast-Reprogramming System-Flash for Digital Equipment ---30
- System-Flash for Amusement Products -----30

### Combination Memories

- Boot Block Type Flash Memory + Pseudo SRAM -----31

## Power Devices/Analog ICs 32

### Power Devices

- Low Power-loss Voltage Regulators -----33
- Surface Mount Type Low Power-loss Voltage Regulators -----35
- Surface Mount Type Chopper Regulators (DC-DC Converters) ---38
- Chopper Regulators (DC-DC Converters) -----39
- Power Supply ICs for CCDs/CCD Camera Modules -----40
- Power Supply ICs for TFT-LCDs -----40
- LED Drivers -----41

### Analog ICs

- Video Interface ICs for TFT-LCDs -----42
- Power Amplifiers for Wireless LAN -----43
- Power Amplifier for Cordless Phones -----43
- Laser Diode Drivers -----44
- IC for Cameras -----44
- Compandor -----44
- ICs for Audio Equipment -----44

## Packages 45

### CSP

- CSP (Chip Size Package) -----46
- Wafer-level CSP -----46

### LGA

- LGA (Land Grid Array Package) -----47

### SiP (System in Package)

- Chip Stacked CSP/TSOP/QFP/VQFN/HQFN -----48
- Package Stacked -----49

### SOF

- SOF (System On Film) -----50

### Package Lineup

- Surface-mount Type -----51
- For CCDs -----54
- Lead-inserting Type [For regulators : PQ series] -----55
- Surface-mount Type [For regulators/LED drivers : PQ series] -----56

## Index (Model No.) 58

# CMOS Image Sensors/ CCDs

## **Camera Modules**

CMOS Camera Modules	3
CCD Camera Modules	4
Peripheral LSI for CCD Camera Modules	4
Power Supply ICs for CCD Camera Modules	4

## **CCDs and Peripheral ICs/LSIs**

CCDs	5
CCD Peripheral ICs/LSIs	6

# CMOS Camera Modules

## CMOS Camera Modules

Module configuration : CMOS image sensor, CDS/AGC/10-bit ADC, timing generator, DSP, lens (for UXGA/SXGA/VGA)  
 CMOS image sensor, CDS/AGC/8-bit ADC, timing generator, DSP, lens (for CIF)  
 Color filter : R, G, B primary color mosaic filters  
 Operating temperature : -20 to 60°C

Optical format	Image format	Optical function	Model No.	Features	Output pixels (H x V) MAX.	Lens			Output signal	Supply voltage (V)	Power consumption (mW) TYP.	Package
						F No.	Con-figuration	Horizontal viewing angle (°)				
1/3.2 type	UXGA	Macro function	LZ0P3955	<ul style="list-style-type: none"> <li>UXGA to SubQCIF</li> <li>15 fps at UXGA/ 30 fps at SVGA</li> <li>5x electronic zoom at QVGA size (MAX.)</li> <li>Image inversion function (right and left)</li> </ul>	1 600 x 1 200	F3.4	3 pcs.	53	UYVY	2.8/1.8 (I/O : 1.8 or 2.8 V)	290 (at 7.5 fps)	28LCC type (Can be socket-mounted)
		Auto focus function	★LZ0P3954			F2.8		57				
1/3 type	SXGA	Macro function	LZ0P393E	<ul style="list-style-type: none"> <li>SXGA to SubQCIF</li> <li>15 fps at SXGA/ 30 fps at QSXGA</li> <li>4.2x electronic zoom at QVGA size (MAX.)</li> <li>Image inversion function (right and left)</li> </ul>	1 280 x 1 024	F2.8	3 pcs.	58	UYVY	2.8/1.8 (I/O : 1.8 or 2.8 V)	150 (at 15 fps)	24LCC type (Can be socket-mounted)
		-	LZ0P3936			F3.2		56				
1/4 type	VGA	Macro function	LZ0P393D	<ul style="list-style-type: none"> <li>SXGA to SubQCIF</li> <li>15 fps at SXGA/ 30 fps at QSXGA</li> <li>4.2x electronic zoom at QVGA size (MAX.)</li> <li>Image inversion function (right and left)</li> </ul>	640 x 480	F2.8	2 pcs.	F3.4	UYVY	2.8/1.8 (I/O : 1.8 or 2.8 V)	110 (at 30 fps)	24LCC type (Can be socket-mounted)
1/6 type		★LZ0P394U	F3.2					56				
1/7 type	CIF	-	LZ0P392N	<ul style="list-style-type: none"> <li>CIF/QCIF</li> <li>30 fps at CIF</li> <li>Image inversion function (right and left)</li> </ul>	352 x 288	Single	-	58	UYVY	2.5 (I/O : 2.8 V)	35 (at 15 fps)	24LCC type (Can be socket-mounted)
			LZ0P392L					65				
1/11 type	VGA	-	★LZ0P396D	<ul style="list-style-type: none"> <li>CIF/QCIF</li> <li>30 fps at CIF</li> <li>Image inversion function (right and left)</li> </ul>	352 x 288	Single	-	56	UYVY	1.8 (I/O : 1.8 or 2.8 V)	12 (at 30 fps)	24LCC type (Can be socket-mounted)
1/11 type			★LZ0P396D					56				

### Outline Dimensions

Model No.	Outline dimensions (mm) TYP.	Package
LZ0P3955	9.5 x 9.5 x (H) 7.0	28LCC type (Can be socket-mounted)
★LZ0P3954	12.0 x 12.0 x (H) 7.2	
LZ0P393E	9.0 x 9.0 x (H) 6.6	24LCC type (Can be socket-mounted)
LZ0P3936	9.0 x 9.0 x (H) 6.4	
LZ0P393D	8.4 x 8.4 x (H) 5.3	
LZ0P393M	8.0 x 8.0 x (H) 4.9	
★LZ0P394U	5.8 x 5.8 x (H) 3.7	
LZ0P394K	6.2 x 6.5 x (H) 4.3	
LZ0P392N	6.5 x 6.5 x (H) 4.5	
LZ0P392L	6.5 x 6.5 x (H) 3.8	
★LZ0P396D	5.5 x 5.5 x (H) 2.4	

(H) : Module height

### System Configuration Example

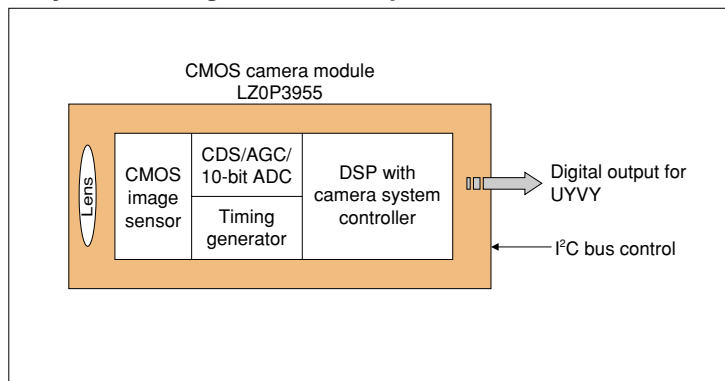

# CCD Camera Modules

## ■ CCD Camera Modules

Module configuration : CCD, CDS/AGC/10-bit ADC, timing generator, V driver, DSP\*, lens, peripheral components  
 Color filter : R, G, B primary color mosaic filters  
 Operating temperature : -20 to 60°C

\* External DSP is required for LZ0P375D/LZ0P3758.

Optical format	Total pixels	Optical function	Model No.	Features	Output pixels (H x V) MAX.	Lens			Output signal	Supply voltage (V)	Power consumption (mW) TYP.	Package
						F number	Con-figuration	Horizontal viewing angle (°)				
1/2.5 type	3.37 M	Auto focus function	<b>LZ0P375D</b>	<ul style="list-style-type: none"> <li>• 2 048 x 1 536 to SubQCIF</li> <li>• 4.5 fps at 2 048 x 1 536/ 10 fps at VGA</li> <li>• 6.4x electronic zoom at QVGA size (MAX.)</li> <li>• Image inversion function (right and left)</li> </ul>	2 048 x 1 536	F2.8	3 pcs.	54	RGB Bayer	1.8, 3.0, 15, -8	400 (at 4.5 fps)	52LCC type
		2x optical zoom/auto focus function	<b>LZ0P3758</b>			F2.8 to 4.1	6 pcs.	Wide : 61 Tele : 33				
1/4 type	1.36 M	Macro function	<b>LZ0P374R</b>	<ul style="list-style-type: none"> <li>• 1 280 x 960 to SubQCIF</li> <li>• 7.5 fps at 1 144 x 880/ 15 fps at QVGA</li> <li>• 4x electronic zoom at QVGA size (MAX.)</li> <li>• Image inversion function (right and left)</li> </ul>	1 280 x 960	F3.4	3 pcs.	60	UYVY	1.8, 3.0, 15, -8 (I/O : 1.8 or 3.0 V)	370 (at 7.5 fps)	64LCC type
			<b>LZ0P374P</b>									54LCC type
		Auto focus function	<b>LZ0P374H</b>			F2.8	46	48LCC type				
1/7 type	350 k	-	<b>LZ0P371K</b>	<ul style="list-style-type: none"> <li>• VGA/CIF/QVGA/QCIF/SubQCIF</li> <li>• 15 fps</li> <li>• 2x electronic zoom at QVGA size (MAX.)</li> <li>• Image inversion function (right and left)</li> </ul>	640 x 480	F2.4	2 pcs.	58	1.8, 3.0, 15, -8 (I/O : 3.0 V)	240 (at 12 fps)	36LCC type	
			<b>LZ0P371L</b>									

## ● Outline Dimensions

Model No.	Outline dimensions (mm) TYP.	Package
<b>LZ0P375D</b>	22.0 x 13.5 x (H) 9.9	52LCC type
<b>LZ0P3758</b>	20.0 x 10.0 x (H) 23.2	40FPC type
<b>LZ0P374R</b>	19.5 x 11.9 x (H) 5.2	64LCC type
<b>LZ0P374P</b>	10.4 x 12.9 x (H) 6.2	54LCC type
<b>LZ0P374H</b>	20.3 x 14.9 x (H) 7.4	48LCC type
<b>LZ0P371K</b>	10.0 x 13.0 x (H) 4.3	36LCC type
<b>LZ0P371L</b>	10.4 x 8.0 x (H) 5.2	

(H) : Module height

## ● System Configuration Example

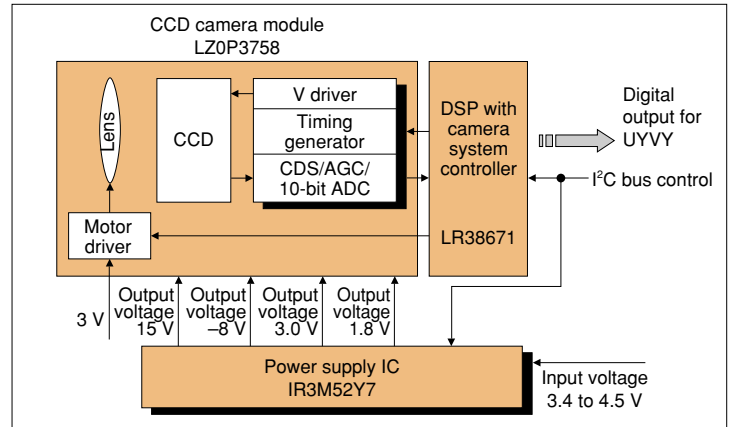

## ■ Peripheral LSI for CCD Camera Modules

Model No.	Function	Features	Package
<b>LR38671</b>	DSP for 3.37-Mpixel CCD camera modules	CCD signal processing circuit, YUV digital output, RGB bayer data output, processing circuit for AWB/AE control, auto white defect detection, stepless electronic zoom, motor driver control, timing generator serial control	TFBGA152-0808

## ■ Power Supply ICs for CCD Camera Modules

Model No.	Function	Output voltage 1 (V)[for CCD]	Output voltage 2 (V)[for CCD]	Output voltage 3 (V)[for CCD]	Output voltage 4 (V)[for DSP]	Output voltage 5 (V)[for I/O]	Input voltage (V)	Package
<b>IR3M48U6</b>	Multi-output power supply for 1/7-type 350-kpixel CCD camera modules	15	-8	-	1.8	-	2.7 to 3.2	P-VQFN032-0505
<b>IR3M52Y7</b>	Multi-output power supply for 1/2.5-type 3.37-Mpixel, 1/4-type 1.36-Mpixel CCD camera modules			2.5 to 3.3	1.2/1.8	2.5 to 3.3	2.7 to 5.5 <sup>*1</sup>	41WL-CSP <sup>*2</sup>

\*1 Since output voltages 3, 4 and 5 are outputs for LDO, an input voltage 0.2 to 0.3 V higher than the output voltages is required.

\*2 3.97 mm x 3.97 mm x 0.82 mm (TYP.)

CMOS Image Sensors/CCDs  
 LSIs for LCDs  
 System LSIs  
 Smart Card Systems  
 Flash Memories/Combination Memories  
 Power Devices/Analog ICs  
 Packages  
 Index (Model No.)



# CCDs and Peripheral ICs/LSIs

CMOS Image Sensors/  
CCDs

LSIs for LCDs

System LSIs

Smart Card Systems

Flash Memories/  
Combination Memories

Power Devices/  
Analog ICs

Packages

Index  
(Model No.)

## Higher-resolution CCDs

Optical format	Total pixels	Color filter	Model No.	30 fps VGA movie	Resolution		Pixel size H x V (μm <sup>2</sup> )	Sensitivity (mV) TYP.	Smear ratio (dB) TYP.	Package
					Image pixels (H x V)					
1/1.7 type	10 540 k	R,G,B primary color mosaic filters	RJ21W3BA0ET	○ (25 fps VGA movie)	3 704 x 2 784		2.05 x 2.05	80		P-SOP032-0525
			RJ21W3CA0ET	—						
1/1.8 type	8 500 k		RJ21V3BC0ET	○	3 320 x 2 496		2.2 x 2.2	105		
			RJ21V3CC0ET	—						
1/2.5 type	5 190 k		RJ23S3BC0ET	○	2 600 x 1 944		2.2 x 2.2		-88	
			RJ23S3CC0ET	—						
			RJ23T3BA0ET	○						
			RJ23T3CA0ET	—						
	6 360 k		★RJ23T3BB0ET	○	2 872 x 2 160		2.05 x 2.05		80	
			★RJ23T3CB0ET	—						
			★RJ23U3BA0ET	○						
			★RJ23U3CA0ET	—						
7 400 k				3 096 x 2 328		1.9 x 1.9	80	-85	P-SOP028-0400	

## 1/3-type CCDs

Total pixels	Standard	Model No.	Electronic shutter (s)	Resolution		Pixel size H x V (μm <sup>2</sup> )	Sensitivity (mV) TYP.	Smear ratio (dB) TYP.	Package	
				Horizontal TV lines	Image pixels (H x V)					
270 k	Color	RJ2311AA0PB	1/60 to 1/10 000	330	512 x 492	9.6 x 7.5	1 300	-120	P-DIP016-0500C	
320 k		RJ2321AA0PB	1/50 to 1/10 000		512 x 582	9.6 x 6.3				
410 k		NTSC	RJ2351AA0BB	1/60 to 1/10 000	480	768 x 494	6.4 x 7.5	800	-105	N-DIP016-0450
		★RJ2351BA0AB	1 200					-120		
470 k		PAL	RJ2361AA0BB	1/50 to 1/10 000	752 x 582	6.5 x 6.3	750	-105		
			★RJ2361BA0AB			6.53 x 6.39	1 100	-120		

## 1/4-type CCDs

Total pixels	Standard	Model No.	Electronic shutter (s)	Resolution		Pixel size H x V (μm <sup>2</sup> )	Sensitivity (mV) TYP.	Smear ratio (dB) TYP.	Package	
				Horizontal TV lines	Image pixels (H x V)					
270 k	Color	RJ2411AA0PB*	1/60 to 1/10 000	330	512 x 492	7.2 x 5.6	800	-105	P-DIP014-0400A	
		RJ2411AB0PB					1 200	-120		
		RJ2411BA0PB*								
		RJ2411BB0PB								
320 k		PAL	RJ2421AB0PB	1/50 to 1/10 000	480	512 x 582	7.2 x 4.7	720		-105
			★RJ2421BB0PB				7.2 x 4.73	1 100		-120
410 k	NTSC	RJ2451AA0PB	1/60 to 1/10 000	480	768 x 494	4.9 x 5.6	400	-90		
470 k	PAL	RJ2461AA0PB	1/50 to 1/10 000	752 x 582	5.0 x 4.7					

\* Suitable for intense light exposure.

## 1/3-type CCDs with Dual-power-supply (5 V/12 V) Operation\*1

Total pixels	Standard	Model No.	Electronic shutter (s)	Resolution		Pixel size H x V (μm <sup>2</sup> )	Sensitivity (mV) TYP.	Smear ratio (dB) TYP.	Package	
				Horizontal TV lines	Image pixels (H x V)					
270 k	B/W	EIA	LZ2316A3	1/60 to 1/10 000	380	512 x 492	9.6 x 7.5	3 300*2	-110	N-DIP016-0500C
320 k		CCIR	LZ2326A3	1/50 to 1/10 000		512 x 582	9.6 x 6.3	3 000*2		

\*1 With mirror image function

\*2 When IR cut-off filter is not used.

## ■ CCD Peripheral ICs/LSIs

Description	Model No.	Features	Package	
Single-chip driver (Timing generator + Synchronous signal generator)	<b>LR385851</b>	For 270-k/320-kpixel CCDs with dual-power-supply operation (5 V/12 V)	Electronic shutter, electronic exposure, mirror image function, for B/W CCDs, level shifter, smooth shutter, line lock function	P-QFP048-0707
Signal processor	<b>IR3Y30M2</b>	Available for signal processing from CCD output to 75 Ω video output, for B/W CCDs, comparator for electronic exposure, high-speed S/H circuit, H aperture, LPF, AGC		P-QFP048-0707
V driver	<b>LR366851</b>	Vertical pulse driver for CCDs, 2-level output x 2, 3-level output x 4, 2-level output circuit for electronic shutter		P-SSOP024-0275
	<b>LR36687U/Y</b>	Vertical pulse driver for CCDs, 2-level output x 10, 3-level output x 10, 2-level output circuit for electronic shutter		P-VQFN064-0808/ TFBGA068-0606
	<b>LR36689U</b>	Vertical pulse driver for CCDs, 2-level output x 4, 3-level output x 8, 2-level output circuit for electronic shutter		P-VQFN036-0505
CDS/PGA/ADC	<b>IR3Y48A3/A5</b>	Low power consumption [80 mW (TYP.)], high-speed S/H circuit, high-gain PGA circuit, 10-bit ADC (18 MHz)		P-QFP048-0707/ P-VQFN052-0707
	<b>IR3Y60U6</b>	Low power consumption [69 mW (TYP.)], high-speed S/H circuit, high-gain PGA circuit, 10-bit ADC (20 MHz)		P-VQFN032-0505
	<b>IR3Y50U6</b>	Low power consumption [75 mW (TYP.)], high-speed S/H circuit, high-gain PGA circuit, 12-bit ADC (25 MHz)		P-VQFN036-0606
Timing generator + V driver + CDS/PGA/ADC	<b>LR38667</b>	For 1/2.5 type 5 190-kpixel CCDs with/without movie function	<Timing generator> Monitoring mode/still mode <V driver> Vertical pulse driver for CCDs, 2-level output x 10, 3-level output x 10, 2-level output circuit for electronic shutter <CDS/PGA/ADC> 30 MHz (LR38667)/ 36 MHz (LR38675/LR38678/LR38674/LR38677), high-speed S/H circuit, high-gain PGA circuit, 12-bit ADC	LFBGA192-1010
	<b>LR38675</b>	For 1/2.5 type 6 360-kpixel CCDs with/without movie function		
	<b>LR38678</b>	For 1/2.5 type 7 400-kpixel CCDs with/without movie function		
	<b>LR38674</b>	For 1/1.8 type 8 500-kpixel CCDs with/without movie function		
	<b>LR38677</b>	For 1/1.7 type 10 540-kpixel CCDs with/without movie function		
V driver + DSP	<b>★LRS5753</b>	For 270-k/320-k/410-k/ 470-kpixel CCDs	<V driver> Vertical pulse driver for CCDs, 2-level output x 2, 3-level output x 2, 2-level output circuit for electronic shutter <DSP> YUV digital output, NTSC/PAL analog output, mirror image function, 9-bit DAC, synchronous signal generation circuit, CCD drive timing generator, processing circuit for AWB/AE control, Y/C separation analog output, line lock function	LFBGA144-0808
V driver + CDS/PGA/ADC + DSP	<b>LR386431/33</b>	For 270-k/320-k/410-k/ 470-kpixel CCDs	<V driver> Vertical pulse driver for CCDs, 2-level output x 2, 3-level output x 2, 2-level output circuit for electronic shutter <CDS/PGA/ADC> 18 MHz, high-speed S/H circuit, high-gain PGA circuit, 10-bit ADC <DSP> YUV digital output, NTSC/PAL analog output, mirror image function, 9-bit DAC, synchronous signal generation circuit, CCD drive timing generator, processing circuit for AWB/AE control, supports monitoring output	LFBGA168-1212/ LFBGA171-0811
	<b>★LR38653</b>		<V driver> Vertical pulse driver for CCDs, 2-level output x 2, 3-level output x 2, 2-level output circuit for electronic shutter <CDS/PGA/ADC> 25 MHz, high-speed S/H circuit, high-gain PGA circuit, 12-bit ADC <DSP> YUV digital output, NTSC/PAL analog output, mirror image function, 10-bit DAC, synchronous signal generation circuit, CCD drive timing generator, processing circuit for AWB/AE control	LFBGA171-0811

CMOS Image Sensors/  
CCDs

LSIs for LCDs

System LSIs

Smart Card Systems

Flash Memories/  
Combination MemoriesPower Devices/  
Analog ICs

Packages

Index  
(Model No.)

■ CCD Peripheral ICs/LSIs (cont'd)

Description	Model No.	Features	Package
DSP + Flash memory + SDRAM	LR38682	For 6 000-kpixel-class CCDs (MAX.)	FBGA424-1414
	LR38683	For 10 000-kpixel-class CCDs (MAX.)	
DSP	LR386032	For 270-k/320-k/410-k/470-kpixel CCDs	P-LQFP080-1212
	LR386071		P-LQFP100-1414
	LR38669A	For 1 300-k to 10 000-kpixel-class CCDs	TFBGA260-1313
Power supply IC for CCDs and peripheral ICs/LSIs	IR3M55U*	For 270-k/320-kpixel CCDs	P-VQFN032-0505
	IR3M59U		
	★IR3M61U*		
	★IR3M63U		

\* For in-vehicle use

CMOS Image Sensors/  
CCDs

LSIs for LCDs

System LSIs

Smart Card Systems

Flash Memories/  
Combination Memories

Power Devices/  
Analog ICs

Packages

Index  
(Model No.)

● System Configuration Examples

● High-resolution Digital Camera System with Three-chip Configuration

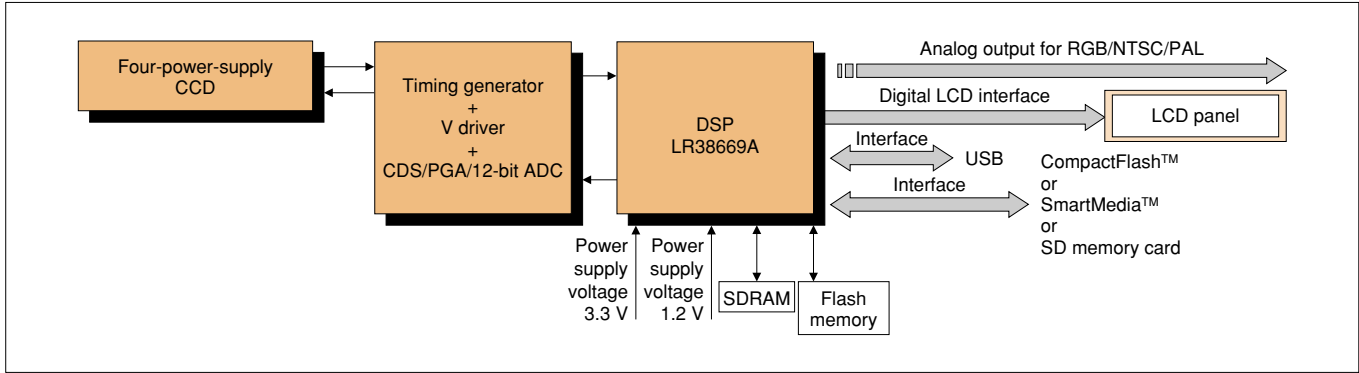

Four-power-supply CCDs and peripheral LSIs

CCD			30 fps VGA movie	Timing generator + V driver + CDS/PGA/ADC	DSP	
Interlace	1/1.7 type	10 540 k pixels	RJ21W3BA0ET	○ (25 fps VGA movie)	LR38669A	
			RJ21W3CA0ET	—		
	1/1.8 type	8 500 k pixels	RJ21V3BC0ET	○		LR38674
			RJ21V3CC0ET	—		
	1/2.5 type	5 190 k pixels	RJ23S3BC0ET	○		LR38667
			RJ23S3CC0ET	—		
		6 360 k pixels	RJ23T3BA0ET	○		LR38675
			RJ23T3CA0ET	—		
			★RJ23T3BB0ET	○		
			★RJ23T3CB0ET	—		
	7 400 k pixels	★RJ23U3BA0ET	○	LR38678		
		★RJ23U3CA0ET	—			

● Color Security Camera System with Two-chip Configuration [Low Power Consumption Type]

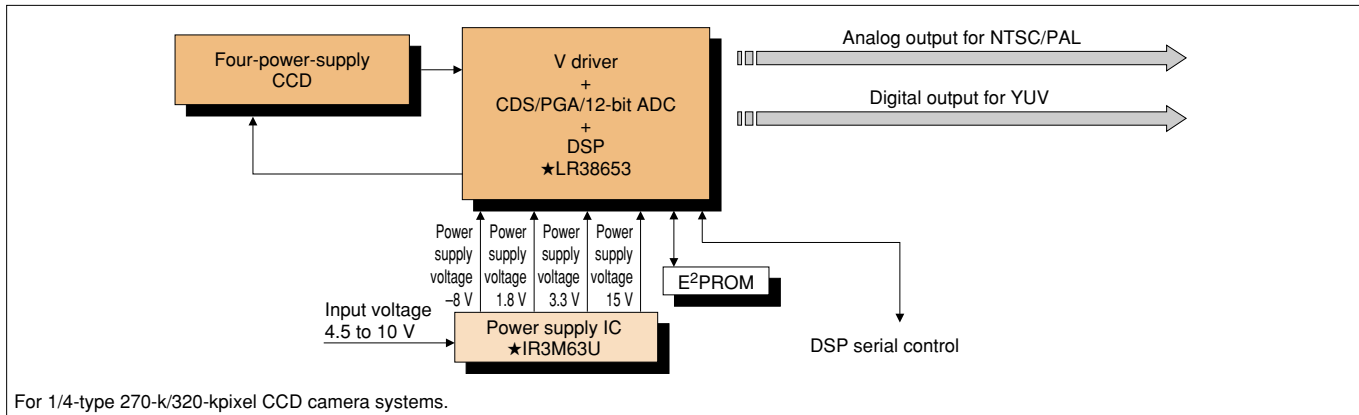

For 1/4-type 270-k/320-kpixel CCD camera systems.

Four-power-supply CCDs and peripheral IC/LSIs

CCD			V driver + CDS/PGA/ADC + DSP	Power supply IC
1/3 type	270 k pixels	RJ2311AA0PB	★LR38653	—
	320 k pixels	RJ2321AA0PB		
	410 k pixels	RJ2351AA0BB		
		★RJ2351BA0AB		
	470 k pixels	RJ2361AA0BB		
1/4 type	270 k pixels	★RJ2361BA0AB	★LR38653	★IR3M63U
		RJ2411AA0PB		
		RJ2411AB0PB		
	320 k pixels	RJ2411BA0PB		
		RJ2411BB0PB		
		RJ2421AB0PB		
		★RJ2421BB0PB		
410 k pixels	RJ2451AA0PB	—		
470 k pixels	RJ2461AA0PB			

CMOS Image Sensors/  
CCDs

LSIs for LCDs

System LSIs

Smart Card Systems

Flash Memories/  
Combination Memories

Power Devices/  
Analog ICs

Packages

Index  
(Model No.)

● Color Security Camera System with Two-chip Configuration

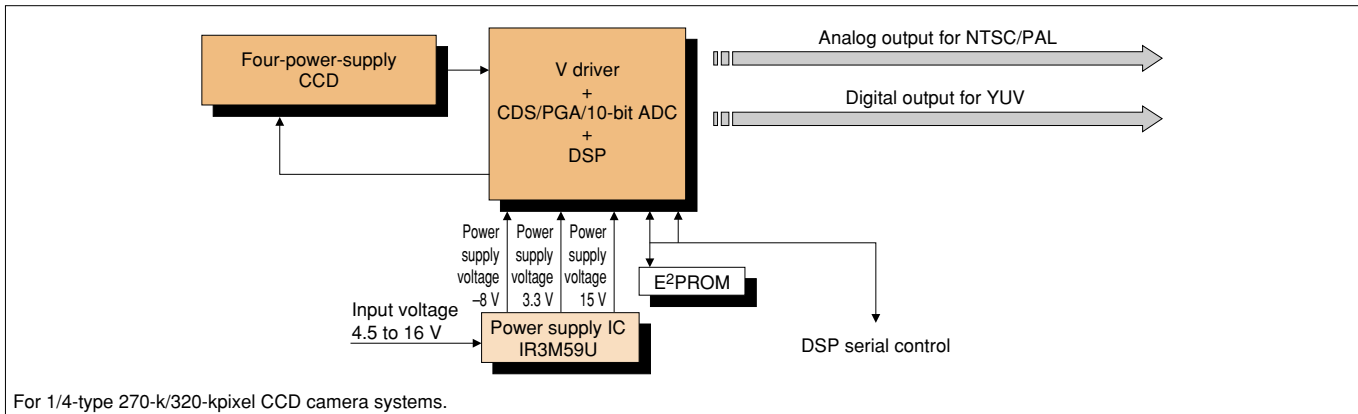

For 1/4-type 270-k/320-kpixel CCD camera systems.

Four-power-supply CCDs and peripheral IC/LSIs

CCD		V driver + CDS/PGA/ADC + DSP	Power supply IC	
1/3 type	270 k pixels	RJ2311AA0PB	—	
	320 k pixels	RJ2321AA0PB		
	410 k pixels	RJ2351AA0BB		
		★RJ2351BA0AB		
	470 k pixels	RJ2361AA0BB		
★RJ2361BA0AB				
1/4 type	270 k pixels	RJ2411AA0PB	LR386431/LR386433	
		RJ2411AB0PB		
		RJ2411BA0PB		
		RJ2411BB0PB		
	320 k pixels	RJ2421AB0PB		IR3M59U
		★RJ2421BB0PB		
	410 k pixels	RJ2451AA0PB		—
	470 k pixels	RJ2461AA0PB		

● Color Security Camera System with three-chip Configuration

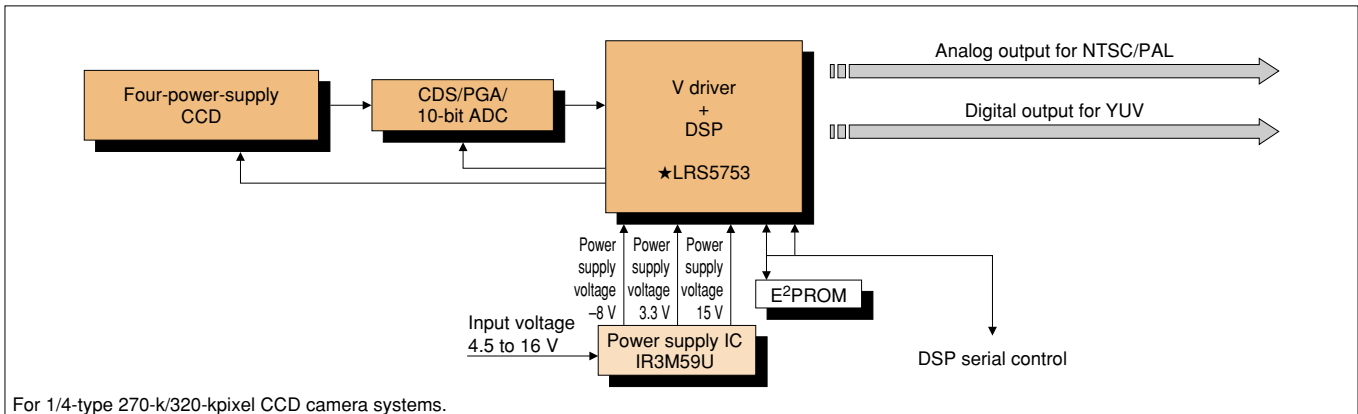

For 1/4-type 270-k/320-kpixel CCD camera systems.

Four-power-supply CCDs and peripheral ICs/LSI

CCD		CDS/PGA/ADC	V driver + DSP	Power supply IC	
1/3 type	270 k pixels	RJ2311AA0PB	IR3Y60U6/IR3Y48A3	—	
	320 k pixels	RJ2321AA0PB			
	410 k pixels	RJ2351AA0BB			
		★RJ2351BA0AB			
	470 k pixels	RJ2361AA0BB			
★RJ2361BA0AB					
1/4 type	270 k pixels	RJ2411AB0PB	★LRS5753	IR3M59U	
		RJ2411BB0PB			
		RJ2421AB0PB			
		★RJ2421BB0PB			
	320 k pixels	RJ2451AA0PB			—
	410 k pixels	RJ2461AA0PB			
	470 k pixels				

● Color Security Camera System with Four-chip Configuration

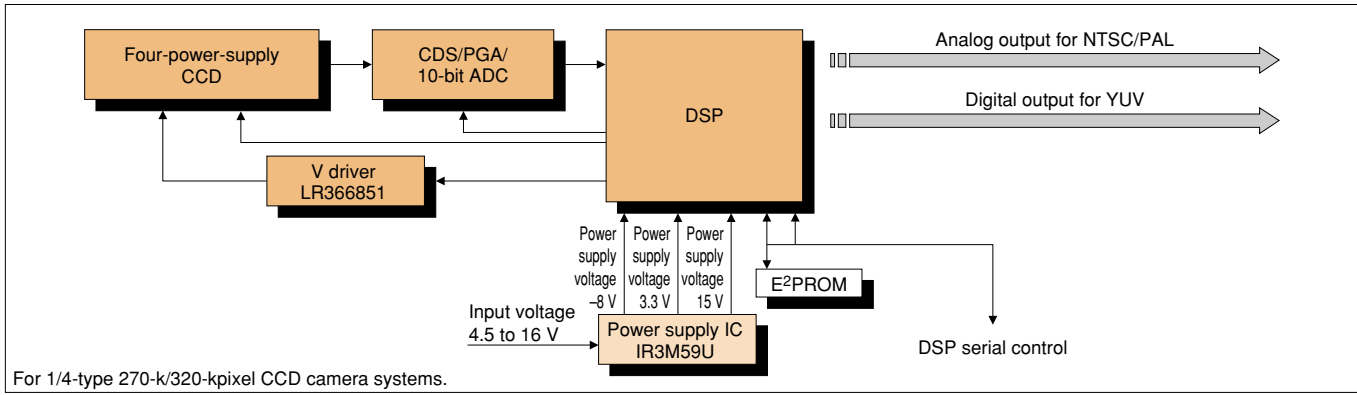

Four-power-supply CCDs and peripheral ICs/LSIs (1)

CCD		V driver	CDS/PGA/ADC	DSP	Power supply IC
1/3 type	270 k pixels	RJ2311AA0PB	IR3Y60U6/IR3Y48A3	LR386071	—
	320 k pixels	RJ2321AA0PB			
	410 k pixels	RJ2351AA0BB			
		★RJ2351BA0AB			
	470 k pixels	RJ2361AA0BB			
1/4 type	270 k pixels	RJ2411AB0PB	IR3M59U	—	
		RJ2411BB0PB			
	320 k pixels	RJ2421AB0PB			
		★RJ2421BB0PB			
	410 k pixels	RJ2451AA0PB			—
470 k pixels	RJ2461AA0PB				

Four-power-supply CCDs and peripheral ICs/LSIs (2)

CCD		V driver	CDS/PGA/ADC	DSP	Power supply IC
1/3 type	270 k pixels	RJ2311AA0PB	IR3Y48A3	LR386032	—
	320 k pixels	RJ2321AA0PB			
	410 k pixels	RJ2351AA0BB			
		★RJ2351BA0AB			
	470 k pixels	RJ2361AA0BB			
1/4 type	270 k pixels	RJ2411AB0PB	IR3M59U	—	
		RJ2411BB0PB			
	320 k pixels	RJ2421AB0PB			
		★RJ2421BB0PB			
	410 k pixels	RJ2451AA0PB			—
470 k pixels	RJ2461AA0PB				

● B/W Security Camera System

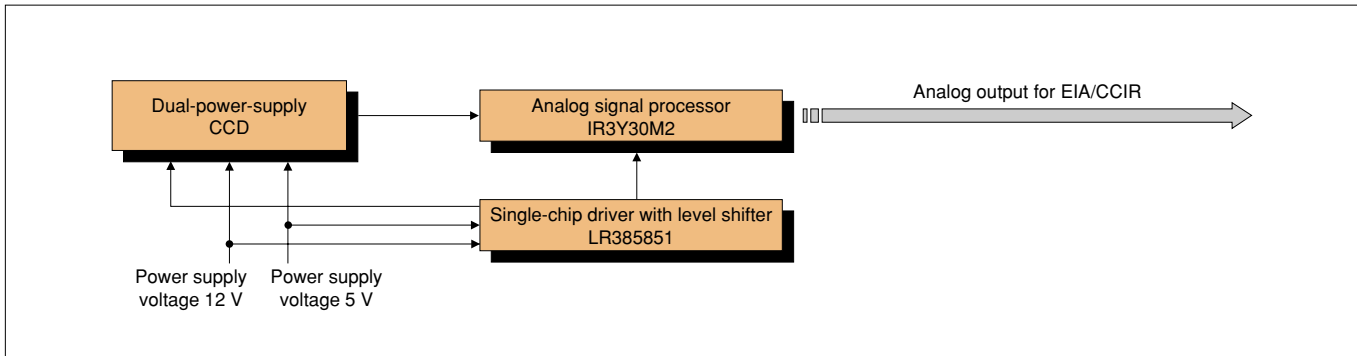

Dual-power-supply CCDs and peripheral IC/LSI for analog interface

CCD		Single-chip driver (Timing generator + Synchronous signal generator)	Signal processor
1/3 type	270 k pixels	LR385851	IR3Y30M2
	320 k pixels		

CMOS Image Sensors/ CCDs  
 LSIs for LCDs  
 System LSIs  
 Smart Card Systems  
 Flash Memories/ Combination Memories  
 Power Devices/ Analog ICs  
 Packages  
 Index (Model No.)

# LSIs for LCDs

## **TFT-LCD**

LCD Drivers	<b>12, 13, 14</b>
LCD Controllers	<b>14</b>
LCD Controllers/Drivers	<b>14</b>
Video Interface ICs	<b>16</b>
Power Supply ICs	<b>16</b>
Gray-scale ICs	<b>16</b>

## **STN-LCD**

LCD Drivers	<b>13</b>
Power Supply IC	<b>13</b>
LCD Controller	<b>15</b>
LCD Controllers/Drivers	<b>15</b>



## LSIs for LCDs

## For Notebook PCs, PC Monitors and LCD TVs

## TFT-LCD Drivers

Drive function	Model No.	Gray scale	No. of LCD drive outputs	Display voltage (V) MAX.	Clock frequency (MHz) MAX.	Supply voltage (V)	Description	Package	
Source driver	Dot inversion drive	64 levels	LH16AM	384	13.5	85	2.7 to 3.6	Low EMI*1 using RSDS™*2 interface, built-in reference voltage generation circuit, R-DAC system	SOF
			LH16B6	414/420/432			2.3 to 3.6		
			LH16AD	480/504/516/528			2.7 to 3.6		
			LH16B0	600			2.3 to 3.6		
			LH16B1	618					
			LH16B2	630					
			LH16B3	642					
			★LH16B5	630/642					
	Line inversion drive	256 levels	LH168R	384	13	65	2.7 to 3.6	2-port data input, built-in reference voltage generation circuit, R-DAC system	TCP/SOF
			LH16AE		15			85	Low EMI*1 using RSDS™*2 interface, built-in reference voltage generation circuit, R-DAC system
			LH16AW	384/414/420	16				
			LH168V	480	13	65	2.5 to 3.6	Selectable clock single-edge (2-port input) or clock dual-edge (1-port input) (built-in data sampling switching function), built-in reference voltage generation circuit, R-DAC system	TCP/SOF
			LH16AF		15			85	2.7 to 3.6
			LH16A1	64 levels	384	5.5	57		
Gate driver	-	LH1691	240	33	0.1	3.0 to 5.5	Selectable 1-pulse (normal) or 2-pulse (continuous/jumping) scanning, usable with both positive/negative power supplies	TCP/SOF/COG	
		LH1694	256	42			2.7 to 3.6	Output signal masking function, usable with both positive/negative power supplies, enables chain connection	TCP/SOF
		LH169G	202/242/258/263/272	45					

\*1 EMI : Electro-Magnetic Interference

\*2 RSDS™ : Reduced Swing Differential Signaling

## For Mobile Equipment

### TFT-LCD Drivers

Drive function		Model No.	Gray scale	No. of LCD drive outputs	Display voltage (V) MAX.	Clock frequency (MHz) MAX.	Supply voltage (V)	Description	Package
Source driver	Dot inversion drive	★LH16AV	64 levels	402/480/516	13.5	65	2.7 to 3.6	Built-in reference voltage generation circuit, R-DAC system, power saving function	COG
	Line inversion drive	LH168Y		240	5.5	35	2.5 to 5.5	Built-in reference voltage generation circuit, R-DAC system, power saving function, polarity inversion of input data	
		LH16AR		480			2.5 to 3.6	Built-in R-DAC system, power saving function, polarity inversion of input data	
		LH1687	Analog	240	12.5	3.0 to 5.5	Selectable three-point simultaneous or normal sampling (Sampling frequency : 25 MHz), power saving function, 3 V drive (MIN.), prechargeless output	TCP/SOF/COG	
Gate driver		LH1691	-	240	33	0.1	2.5 to 3.6	Selectable 1-pulse (normal) or 2-pulse (continuous/jumping) scanning, usable with both positive/negative power supplies	COG
		★LH169H		240/244/258	40			Output signal masking function, enables chain connection	

### STN-LCD Drivers

Drive technology	Drive function	Model No.	No. of LCD drive outputs	Duty ratio	Display voltage (V) MAX.	Data input	Clock frequency (MHz) MAX.	Supply voltage (V)	Package
New drive technology*1	Segment	LH1583	160	to 1/240	+5.5	4/8-bit parallel	12 (at 2.4 V) / 20 (at 5 V)	2.4 to 5.5	TCP/SOF
		LH1580	240	to 1/480		8/12-bit parallel	30 (at 2.5 V) / 55 (at 5 V)	2.5 to 5.5	
	Common	LH1537	200/240	1/200, 1/240	+45	-	3 (at 2.4 V) / 4 (at 5 V)	2.4 to 5.5	
		LH1538	120/128	to 1/480	+80		3 (at 2.5 V) / 4 (at 5 V)		
Conventional drive technology*2	Segment	LH1542	80	to 1/240	+30	4-bit parallel	8	2.5 to 5.5	
		LH1549	160	to 1/480	+42	4/8-bit parallel	12 (at 2.5 V) / 20 (at 5 V)		
		LH1548	240			8/12-bit parallel	12 (at 2.5 V) / 25 (at 5 V)		
	Common	LH1530	120	to 1/480	+42	-	3 (at 2.5 V) / 4 (at 5 V)		
		LH1565	160	to 1/240	+30		[Segment mode] 8 [Common mode] 4		
		LH1560		to 1/480	+42		4/8-bit parallel (at segment drive) 8 (at 2.5 V) / 14 (at 5 V) [Common mode] 4		
	LH1562	240			[Segment mode] 12 (at 2.5 V) / 20 (at 5 V) [Common mode] 4				

\*1 New drive technology : A drive technology which drives LCDs with low voltage of 5 V on segment side and drives LCDs with high voltage on common side. Driving with low voltage on segment side enables LCDs to reduce power consumption and shadowing.

\*2 Conventional drive technology : A drive technology which drives LCDs with high voltage on both segment and common sides.

### Power Supply IC for STN-LCD Drivers

Model No.	Description	Supply voltage (V)	Package
LR3697A	For STN LCD drivers with new drive technology* DC-DC converter for LCD drive power supply, built-in bias voltage generation circuit for LCD drive, electronic volume control circuit	2.4 to 3.3 (V <sub>DD</sub> , V <sub>P</sub> )	P-QFP072-1010

\* New drive technology : A drive technology which drives LCDs with low voltage of 5 V on segment side and drives LCDs with high voltage on common side. Driving with low voltage on segment side enables LCDs to reduce power consumption and shadowing.

## For Cellular Phones

### TFT-LCD Controller/Driver with Two-chip Configuration (LR38825 + LH169C)

Model No.	No. of LCD drive outputs		Display colors MAX.	Display RAM capacity (bit)	a-Si	Function	CPU interface	External image interface	Supply voltage (V)			Package
	Source	Gate							Core	Host I/F	Display	
LR38825	528	—	262 144 colors	240 x 176 x 18	○	<ul style="list-style-type: none"> <li>Versatile graphic functions</li> <li>Window display function</li> <li>Write mask function</li> <li>Bit built function</li> <li>Built-in gray-scale control circuit</li> <li>Built-in timing generator</li> </ul>	80-family (8/16/18-bit parallel, serial)	RGB : respective 6-bit parallel	1.65 to 1.95	1.65 to 3.6	4.75 to 5.25	COG
LH169C	—	240		—	○	<ul style="list-style-type: none"> <li>Built-in DC-DC converter, VCOM generation circuit</li> </ul>	—	—	2.75 to 3.3		26.5 (MAX.)	

### Single-chip TFT-LCD Controller/Driver

Model No.	No. of LCD drive outputs		Display colors MAX.	Display RAM capacity (bit)	a-Si	Function	CPU interface	External image interface	Supply voltage (V)			Package
	Source	Gate							Core	Host I/F	Display	
LR38826	396	176	262 144 colors	176 x 132 x 18	○	<ul style="list-style-type: none"> <li>Versatile graphic functions</li> <li>Window display function</li> <li>Write mask function</li> <li>Bit built function</li> <li>Built-in gray-scale control circuit</li> <li>Built-in timing generator, DC-DC converter, VCOM generation circuit</li> </ul>	80-family (8/16/18-bit parallel, serial)	RGB : respective 6-bit parallel, YUV format	1.65 to 1.95	1.65 to 3.6	2.75 to 3.3 (Using built-in power supply *Source : 4.0 to 5.5 *Gate : 20 to 27.5)	COG

### TFT-LCD Controllers

Model No.	LCD interface (pixel) MAX.	Display colors MAX.	Display RAM capacity (bit)	a-Si	Function	CPU interface	External image interface	Supply voltage (V)		Package
								Core	Host I/F	
LR38822A	176 x 240	65 536 colors	176 x 240 x 16	○	<ul style="list-style-type: none"> <li>Built-in timing generator, clock generator</li> </ul>	80-family (8/16-bit parallel, serial)	RGB : respective 6-bit parallel	2.25 to 2.75	3.0 to 3.6	TFBGA112-1010
LR38869A	240 x 400	262 144 colors	240 x 400 x 18	○	<ul style="list-style-type: none"> <li>MDDI* compliant</li> <li>Main/sub LCD controller</li> <li>Graphic processing</li> <li>Parallel bus host interface</li> </ul>	MDDI* for MSM series/ 80-family (8/9/16/ 18-bit parallel)	—	1.65 to 1.95	1.65 to 3.6	TFBGA176-0909

\* MDDI (Mobile Display Digital Interface) : The serial interface standard developed by QUALCOMM.

### TFT-LCD Driver

Model No.	No. of LCD drive outputs		LTSPS*	Function	External image interface	Supply voltage (V)		Package
	Source	Gate				Core	Display MAX.	
LH16AP	240	—	○	<ul style="list-style-type: none"> <li>Built-in timing generator, DC-DC converter, VCOM generation circuit</li> </ul>	RGB : respective 6-bit parallel	2.2 to 3.6	5.5	COG/SOF

\* LTSPS : Low Temperature Poly-Silicon

## ■ Color STN-LCD Controllers/Drivers

Display colors MAX.	Drive function	Model No	No. of LCD drive outputs		Display RAM capacity (bit)	Duty ratio	Display voltage (V) MAX.	Data input	Clock frequency (MHz) MAX.	Supply voltage (V)	Package
			Segment	Common							
256 colors	Segment and Common	LH15H1	288	66	96 x 66 x 8	1/10, 1/18, 1/26, 1/34, 1/42, 1/50, 1/58, 1/66	+13.2	8/16-bit parallel, serial	4 (at 3 V)	1.8 to 3.3	TCP/SOF
4 096 colors		LH15JA	396	132	132 x 132 x 12	1/33, 1/39, 1/68, 1/74, 1/133, 1/139	+18	8-bit parallel, serial	3 (at 2.5 V)	1.65 to 3.3	COG
65 536 colors		LH15KA		176	132 x 176 x 16	to 1/176 (Selectable per 1 line)	+18.6	8/16-bit parallel, serial	4 (at 3 V)	1.8 to 3.3	COG/SOF
262 144 colors		★LH15LA		162	132 x 162 x 18	to 1/162 (Selectable per 1 line)	±18		6.25 (at 1.65 to 1.95)	Core : 1.65 to 1.95 Host I/F : 1.65 to 3.6	COG

## ■ Color STN-LCD Controller

Model No.	LCD interface (pixel) MAX.	Display colors MAX.	Function/Feature	CPU interface	Display RAM capacity (bit)	Supply voltage (V) TYP.	Package	
LR38844A	128 x 164	65 536 colors	<ul style="list-style-type: none"> <li>High-speed host access</li> <li>Display colors selectable : 256/4 096/65 536 colors</li> <li>Power saving function reduces the power consumption in standby mode</li> <li>Built-in CPU interface, LCD interface, clock generator, display memory</li> </ul>	Recommended to be used together with LH15H1	68-family/ 80-family (8/16 bits)	128 x 164 x 16	2.5	TFBGA081-0808

## Peripheral ICs for LSIs for LCDs

### Video Interface ICs for TFT-LCDs

Model No.	Input signal				Color decode	LCD panel				Serial data control	Supply voltage (V) TYP.	Power consumption (mW) TYP.	Package
	Composite video	Y/color difference	Analog RGB	OSD (Digital)		± power source	+ power source	Low voltage source	Digital input				
IR3Y18A1	○				NTSC/PAL	○	○				4.5/12 or 4.5/-7.5	130	P-QFP048-0707
IR3Y26A2/A6			○*3		-			○			5/7.5	140	P-QFP048-1010/ P-QFP048-0707
IR3Y29A1/B1	○		○		NTSC/PAL			○				190	P-QFP048-0707
IR3Y31M1	○		○		NTSC/PAL	○	○				4.5/12 or 4.5/-7.5	160	
IR3Y34M1		○	○	○	-		○				3/12	88	P-QFP048-0707
IR3Y37A1		○(Common terminal)		○	-			○			3/6.5	106/88*4	
RB5P0010M2			○*3	○	-	○	○		○		3/12 or 3/4.5/-7.5	92	P-QFP048-0707
RB5P0020M2		○(Common terminal)		○	-			○			3/5	70/57*4	
RB5P0050M2		○(Common terminal)		○	-			○	○		3/5/13	95/80*4	P-QFP048-1010
RB5P0060M2	○		○		NTSC/PAL			○	○			120	
RB5P006AM2	○		○		NTSC/PAL			○	○				P-QFP072-1010
RB5P0070M*1	○		○	○	NTSC/PAL				○	○	3/7	330	
RB5P0090M	○		○*3		NTSC/PAL (automatic identification)			○	○		5/13	250	P-LQFP100-1414
LRS5751*2	○		○		NTSC/PAL			○			3.3/5/7.5	197	
LRS5752*2	○		○*3		NTSC/PAL (automatic identification)			○	○		3.3/5/13	257	

\*1 For digital signal input panels \*2 Built-in timing generator \*3 Two inputs \*4 At analog input for RGB

### Power Supply ICs for TFT-LCDs

Model No.	Application/Function	Oscillation frequency (kHz)	Supply voltage (V)	Package
IR3M16U	For small TFT-LCD panels, charge pump system DC-DC converter (15.3 V, 5.1 V, -10.2 V)	100	2.6 to 3.6	P-HQFN020-0404
IR3M30M/U	For small/medium TFT-LCD panels, PWM switching system DC-DC converter (Output voltage (3ch) : External setting)	70 to 1 000	2.7 to 5.5	P-QFP048-0707/ P-VQFN036-0505
★IR3M58M/U		70 to 500	4.5 to 28	

### Gray-scale ICs for TFT-LCDs

Model No.	Panel type	Function	No. of output circuits	Output current (mA) MAX.	Common output current (mA) MAX.	Supply voltage (V)	Package
IR3E2015	<ul style="list-style-type: none"> <li>• Small panels</li> <li>• Line inversion drive</li> </ul>	γ correction, gray-scale voltage generator for LCD drivers, built-in dividing resistors	10	±1	±1	4.5 to 5.5	P-MFP018
IR3E2045			5			4.6 to 5.5	P-SSOP012-0225/ P-HQFN020-0404
IR3E3XX*							
IR3E11P1	<ul style="list-style-type: none"> <li>• Large panels</li> <li>• Up to 20-inch panels</li> <li>• SXGA/UXGA</li> <li>• Dot inversion drive</li> </ul>	γ correction, gray-scale voltage generator for LCD drivers	10	±15	±150	7 to 14	P-QFP048-0707
IR3E11A1						7 to 15	P-TQFP048-0707
IR3E11M1						7 to 14	
IR3E12M1						7 to 15	
IR3E13N/U						<ul style="list-style-type: none"> <li>• Medium/large panels</li> <li>• Dot inversion drive</li> </ul>	6

\* SHARP can offer semi-custom-made gray-scale ICs in accordance with the characteristics of LCD panels.

# System LSIs

## **Special-function LSIs** 18

### **ARM RISC Core LSIs**

ARM RISC Core ASSPs for Mobile Equipment 19

Startup Kit for ARM Embedded Linux™ 19

Development Environment for  
ARM Microprocessors 19

ARM Universal Microcontroller 20

Development Environment for  
ARM Microprocessors 21

### **IPs**

CPU Cores 22

Peripherals 22

Analog Cells 22

Analog PLL 22

Others 22

 System LSIs

## Special-function LSIs

Model No.	Function	Features	Supply voltage (V)	Package
LR35501/Y	Home & amusement processor	<ul style="list-style-type: none"> <li>Capable of moving picture play/record, thanks to real-time image compression and extension technology</li> <li>Real images, backgrounds and sprites can be superimposed</li> <li>Built-in sprite processor</li> <li>Built-in color object detector</li> <li>Built-in Bluetooth interface</li> <li>Built-in sound generator (ADPCM/PSG)</li> <li>Built-in CMOS camera module interface</li> <li>Built-in video encoder : NTSC/PAL compatible signal output</li> <li>Analog RGB signal output</li> <li>CPU : Z80 compatible</li> <li>PIO, UART, SIO, MMU, NAND flash memory I/F, ADC, etc.</li> </ul>	Core : 1.8 ± 0.18 I/O : 3.3 ± 0.3	P-QFP128-1420/ TFBGA160-1212
★LR38886	Image detection engine	<ul style="list-style-type: none"> <li>High-speed image processing : 960 MOPS (MAX.)</li> <li>Built-in camera interface : 8-bit digital input (UYVY etc.)</li> <li>Built-in SDRAM interface : 512 Mbits (MAX.)</li> <li>Universal I/O : 32 bits (MAX.)</li> <li>Serial interface (SPI)</li> <li>Bus interface (Bus Master/Slave)</li> <li>Built-in PLL</li> <li>Low power consumption : 250 mW (at 15 fps/VGA)</li> </ul>	Core : 1.8 (TYP.) I/O : 3.3 (TYP.)	P-LQFP176-2424
LR38875	RSDS transmitter	<ul style="list-style-type: none"> <li>RSDS<sup>TM*1</sup> spec. V095 compliant</li> <li>Low EMI<sup>*2</sup> generation</li> <li>Low current consumption : 50 mA (MAX. at 85 MHz)</li> <li>High noise rejection</li> <li>Data rate : 50 to 180 Mbps (CLK : at 25 to 90 MHz)</li> <li>Clock delay timing of RSDS<sup>TM*1</sup> output can be controlled by external register</li> <li>RSDS<sup>TM*1</sup> swing output voltage can be controlled by external load resistor</li> </ul>	3.3 ± 0.3	P-TQFP100-1414
LR38888	H. 264 decoding signal processor	<ul style="list-style-type: none"> <li>Built-in video (H. 264) and audio (MP3/AAC/AAC + SBR) decoding functions</li> <li>Low current consumption : 125 mA (at 1.3 V)</li> <li>Fast play</li> <li>Built-in memory (DRAM)</li> <li>Input signal : MPEG2-TS</li> <li>Image size : QVGA</li> <li>Frame rate : 15 frames/s</li> <li>Output signal format : Image UYVY/RGB for video, I<sup>2</sup>S for audio</li> <li>Output interface : CPU bus, camera interface</li> </ul>	Core : 1.3 (TYP.) I/O : 1.8 (TYP.)	TFBGA208-1010
LR38669A	DSP for 1 300-k to 10 000-kpixel-class CCDs	<ul style="list-style-type: none"> <li>Built-in CCD signal processing circuit, ARM core, JPEG (hardware), memory controller, video encoder (NTSC/PAL), USB line driver</li> <li>Supports CompactFlash<sup>TM</sup>/SmartMedia<sup>TM</sup>/SD memory card interfaces</li> <li>Supports several types of LCD digital interfaces</li> <li>Support for CCDs with movie function</li> </ul>	Core : 1.2 (TYP.) I/O : 3.3 (TYP.)	TFBGA260-1313
LR38682	System LSI for digital cameras (for 6 000-kpixel-class CCDs [MAX.])	<p>&lt;DSP&gt;</p> <ul style="list-style-type: none"> <li>Built-in CCD signal processing circuit, ARM core, JPEG (hardware), memory controller, video encoder (NTSC/PAL), USB line driver</li> <li>Supports CompactFlash<sup>TM</sup>/SmartMedia<sup>TM</sup>/SD memory card interfaces</li> <li>Supports several types of LCD digital interfaces</li> <li>Support for CCDs with movie function</li> </ul> <p>&lt;Flash memory&gt;</p> <ul style="list-style-type: none"> <li>Capacity : 32 Mbits</li> <li>Bit configuration : x 16</li> <li>Access time : 100 ns (MAX.)</li> <li>4-Kword reprogramming time (Program + erase) : 0.42 s (Program 0.06 s + Erase 0.35 s)</li> </ul>	<p>&lt;DSP&gt;</p> <p>Core : 1.2 (TYP.) I/O : 3.3 (TYP.)</p> <p>&lt;Flash memory&gt; 3.3 (TYP.)</p>	FBGA424-1414
LR38683	System LSI for digital cameras (for 10 000-kpixel-class CCDs [MAX.])	<p>&lt;SDRAM&gt;</p> <ul style="list-style-type: none"> <li>Capacity : 256 Mbits (LR38682), 256 Mbits x 2 (LR38683)</li> <li>Burst length (BL) : 1, 2, 4, 8, full page</li> <li>CAS latency (CL) : 2, 3</li> <li>Frequency : 100 MHz (MAX.)</li> </ul>	<p>&lt;SDRAM&gt; 3.3 (TYP.)</p>	
LR388733	USB On-The-Go controller	<ul style="list-style-type: none"> <li>USB2.0 supplemental standard OTG1.0 compliant</li> <li>Connectable to a product whose data transfer speed (12 Mbps and 1.5 Mbps) conforms to USB2.0</li> <li>Built-in 2-ch USB line driver (2-port root HUB function)</li> <li>Asynchronous SRAM-compatible interface</li> <li>Supports 4 transfer modes (control, bulk, interrupt and isochronous)</li> </ul>	Core : 3.3 (TYP.) I/O (USB) : 5 (TYP.)	P-QFP072-1010

\*1 RSDS<sup>TM</sup> : Reduced Swing Differential Signaling

\*2 EMI : Electro-Magnetic Interference

## ARM RISC Core LSIs

### ARM RISC Core ASSPs for Mobile Equipment

Model No.	Core CPU	Configuration	Operating frequency (MHz) MAX.	Supply voltage (V)	Power consumption (mW) MAX.	Package	Remarks
LH79532A/Y	ARM7TDMI	Cache memory (4 Kbytes) + UART + PIT + RTC + PWM + INTC + PIO + WDT + RPC + Color LCDC + DMAC + SDRAMC + PLL	50	Core : 2.35 to 2.75 I/O : 3.0 to 3.6	325 (at 50 MHz)	P-LQFP176-2424/ TFBGA180-1212	<ul style="list-style-type: none"> <li>ASSP for color and B/W LCDs</li> <li>LCDC : Supports TFT/CSTN/STN, single/dual scanning, SVGA [800 x 600 pixels] (MAX.)</li> </ul>
LH79533A	ARM7TDMI	UART + PIT + RTC + PWM + INTC + PIO + WDT + RPC + Color LCDC + DMAC + SDRAMC + PLL + SRAM (16 Kbytes)	50	Core : 1.62 to 1.98 I/O : 3.0 to 3.6	200 (at 50 MHz)	P-LQFP144-2020	<ul style="list-style-type: none"> <li>ASSP for color and B/W LCDs</li> <li>LCDC : Supports CSTN/STN, VGA [640 x 480 pixels] (MAX.)</li> </ul>

### Startup Kit for ARM Embedded Linux™\* (LH0E776)

The LH0E776 is a startup kit which facilitates the evaluation and debugging of the ARM RISC core ASSP, LH79532A and ARM embedded Linux™. It incorporates the LH79532A as a CPU, memories (including a flash memory and SDRAMs) and communication ports (including Ethernet and RS-232C), as well as a JTAG port for debugging. SHARP is also able to provide an embedded Linux™ source.

#### Features

##### Simple operability

Simply applying power enables evaluation of Linux™ and LH79532A.

##### Compact board

A7 size

##### Mounting devices

CPU : LH79532A (ARM7TDMI core)

Flash memory : 4 Mbytes (2 Mwords x 16 bits)

SDRAM : 32 Mbytes (8 Mwords x 32 bits)

Ethernet communication port : 1 ch

RS-232C communication port : 2 ch

JTAG connector

\* Joint development with AXE Inc.

#### Board Configuration

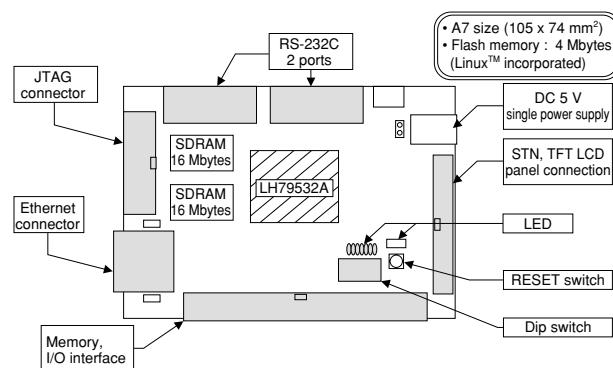

### Development Environment for ARM Microprocessors

In order to ensure the functionality of a system LSI based on a RISC processor and speedy development of the products, an advanced software development environment, a real-time OS and middleware are required.

The required development environment and tools, such as software, real-time OS and middleware can be obtained by customers from third party vendors.

#### Software Environment

RealView v2.0	ARM Ltd.
MULTI-2000 IDE	Green Hills Software Inc.

#### Emulator

RealView, Multi-ICE	ARM Ltd.
MAJIC, JEENI	Embedded Performance Inc.
advicePLUS	Yokogawa Digital Computer Corporation

#### Real Time OS

μITRON 4.0	eSOL Corporation, ACCESS Corporation, Elmic Systems Inc.
Linux™, Embedded Linux™	Lineo Inc., Red Hat Inc., Montavista Software Inc., AXE Inc., ELT Inc.

#### Middleware

TCP/IP, PPP, IPv6	ACCESS Corporation, eSOL Corporation
Graphics, File system	Elmic Systems Inc., AXE Inc.

## ARM Universal Microcontroller

Model No.	Core CPU	Configuration	Operating frequency (MHz) MAX.	Supply voltage (V)	Power consumption (mW) Typical	Power consumption (mW) MAX.	Package	Remarks
LH75400	ARM7TDMI	SRAM (32 Kbytes) + LCDC + CAN + 10-bit ADC + UART + Timer + RTC + PMC + WDT + DMAC	84	Core : 1.7 to 1.98 I/O : 3.0 to 3.6	149 (At 84 MHz)	209 (At 84 MHz)	144LQFP	<ul style="list-style-type: none"> <li>• ASSP for B/W LCDs</li> <li>• LCDC : Supports STN, XGA [1 024 x 768 pixels] (MAX.)</li> <li>• CAN-Ver 2.0B</li> </ul>
LH75401	ARM7TDMI		84	Core : 1.7 to 1.98 I/O : 3.0 to 3.6	149 (At 84 MHz)	209 (At 84 MHz)	144LQFP	<ul style="list-style-type: none"> <li>• ASSP for color and B/W LCDs</li> <li>• LCDC : Supports XGA [1 024 x 768 pixels] (MAX.), 4 K colors (MAX.)</li> <li>• CAN-Ver 2.0B</li> </ul>
LH75410	ARM7TDMI	SRAM (32 Kbytes) + LCDC + 10-bit ADC + UART + DMAC + Timer + RTC + PMC + WDT	84	Core : 1.7 to 1.98 I/O : 3.0 to 3.6	149 (At 84 MHz)	209 (At 84 MHz)	144LQFP	<ul style="list-style-type: none"> <li>• ASSP for B/W LCDs</li> <li>• LCDC : Supports STN, XGA [1 024 x 768 pixels] (MAX.)</li> </ul>
LH75411	ARM7TDMI		84	Core : 1.7 to 1.98 I/O : 3.0 to 3.6	149 (At 84 MHz)	209 (At 84 MHz)	144LQFP	<ul style="list-style-type: none"> <li>• ASSP for color and B/W LCDs</li> <li>• LCDC : Supports XGA [1 024 x 768 pixels] (MAX.), 4 K colors (MAX.)</li> </ul>
LH79520	ARM720T	Cache memory (8 Kbytes) + MMU + SRAM (32 Kbytes) + LCDC + DMAC + UART + Timer + RTC + PWM + PMC + WDT	77.4	Core : 1.62 to 1.98 I/O : 3.0 to 3.6	92 (At 77.4 MHz)	128 (At 77.4 MHz)	176LQFP	<ul style="list-style-type: none"> <li>• ASSP for color and B/W LCDs</li> <li>• LCDC : Supports SVGA [800 x 600 pixels] (MAX.), 64 K colors</li> </ul>
LH79524	ARM720T	Cache memory (8 Kbytes) + MMU + SRAM (16 Kbytes) + LCDC + USB + Ethernet MAC + DMAC + 10-bit ADC + UART + Timer + RTC + PWM + PMC + WDT	76.2	Core : 1.7 to 1.9 I/O : 3.0 to 3.6	181 (At 76.2 MHz)	247 (At 76.2 MHz)	208CABGA	<ul style="list-style-type: none"> <li>• ASSP for color and B/W LCDs</li> <li>• LCDC : Supports SVGA [800 x 600 pixels] (MAX.), 4 K colors (LH79525)/ 64 K colors (LH79524)</li> <li>• USB 2.0 (Device, Full speed)</li> <li>• Ethernet MAC</li> </ul>
LH79525	ARM720T		76.2	Core : 1.7 to 1.9 I/O : 3.0 to 3.6	181 (At 76.2 MHz)	247 (At 76.2 MHz)	176LQFP	
LH7A400	ARM922T	ICache memory (8 Kbytes) + DCache memory (8 Kbytes) + MMU + SRAM (80 Kbytes) + LCDC + RTC + DMAC + USB + UART + Timer + SmartCard + MMC + WDT + PMC	200 250	<At 200 MHz> Core : 1.71 to 1.89 I/O : 3.0 to 3.6 <At 250 MHz> Core : 2.0 to 2.2 I/O : 3.0 to 3.6	247 (At 200 MHz) 561 (At 250 MHz)	417 (At 200 MHz) 728 (At 250 MHz)	256PBGA 256CABGA	<ul style="list-style-type: none"> <li>• ASSP for color multimedia and portable applications.</li> <li>• LCDC : Supports XGA [1 024 x 768 pixels] (MAX.), 64 K colors</li> <li>• USB 2.0 (Device, Full speed)</li> </ul>
LH7A404	ARM922T	ICache memory (8 Kbytes) + DCache memory (8 Kbytes) + MMU + SRAM (80 Kbytes) + LCDC + RTC + DMAC + USB (Device/Host) + UART + Timer + SmartCard + MMC + WDT + PMC + 10-bit ADC	200 266	<At 200 MHz> Core : 1.7 to 1.98 I/O : 3.0 to 3.6 <At 266 MHz> Core : 2.0 to 2.2 I/O : 3.0 to 3.6	287 (At 200 MHz) 443 (At 266 MHz)	565 (At 200 MHz) 1 015 (At 266 MHz)	324CABGA	<ul style="list-style-type: none"> <li>• ASSP for color multimedia and portable applications.</li> <li>• LCDC : Supports XGA [1 024 x 768 pixels] (MAX.), 64 K colors</li> <li>• USB 2.0 (Device, Full speed)</li> <li>• USB 2.0 (Host, Full speed)</li> </ul>

### Sales Contact

#### SHARP MICROELECTRONICS OF THE AMERICAS (SMA)

North American Head Office  
 Address : 5700 NW Pacific Rim Boulevard, Camas, Washington 98607  
 Phone : (1) 360-834-2500  
 Fax : (1) 360-834-8903  
<http://www.sharpmcu.com>

## ■ Development Environment for ARM Microprocessors

### ● Compilers/Assemblers

ARM Developer Suite, ADS v1.2	ARM Ltd.
ARM RealView Developer Suite	ARM Ltd.
MULTI IDE	Green Hills Software Inc.
EWARM	IAR Systems Inc.
GCC	GNU

### ● JTAG Debuggers

Multi-ICE	ARM Ltd.
Slingshot, Probe	Green Hills Software Inc.
BDI 2000	Abatron Inc.
Vitra, Genia, Opella, PathFinder	Ashling Microsystems Ltd.
JTAGjet-ARM	Signum Systems Corporation
TRACE32 In-Circuit Debugger	Lauterbach Inc.
EMUL-ARM	Nohau a DBA of Knowit LLC
MAJIC-ICE	Embedded Performance Inc.

### ● Evaluation Boards/Single Board Computers

Zoom Starter Kits, Integrated	Logic Product Development Inc.
Developers Kit, Card Engines	
Single Board Computers	Revely Microsystems
Single Board Computers	Cogent Computer Systems Inc.
Evaluation Boards	Yokogawa Digital Computer Corporation

### ● RTOS/OS/BSP

Windows CE .NET	Microsoft Corporation
Windows CE .NET 4.2 BSP	BSQUARE Corporation
Windows CE .NET 5.0 BSP, Linux	Logic Product Development Inc.
Windows CE 5.0 BSP	Sharp Microelectronics of the Americas
Linux 2.4 BSP	Metrowerks V2.4
Linux 2.6 BSP	Sharp Microelectronics of the Americas
ThreadX	Express Logic Inc.
Nucleus+	Accelerated Technologies Inc.
VxWorks	Wind River Systems Inc.

### ● Design Services

Full service, Mechanical, Industrial, Electrical, Systems & Software, PCB Design & Layout, FPGA	Logic Product Development Inc.
Full service, Mechanical, Industrial, Electrical, Systems & Software, PCB Design & Layout, FPGA	Wind River Systems Inc.

## IPs

The IPs contribute to shorter development time, effective use of existing software and improvement in reliability. SHARP is promoting a comprehensive range of IPs to provide support for top-down design using logic synthesis.

### CPU Cores

IP	Macro	Function	Data type	
			Hard	Soft
ARM	ARM7TDMI	32-bit RISC ARM7TDMI CPU Core (16-bit Ins. mode supported)	<input type="radio"/>	<input type="radio"/>
	ARM720T	ARM7TDMI + MMU + 8-Kbyte Cache	<input type="radio"/>	
	ARM922T	ARM9TDMI + MMU + 8-Kbyte I-cache + 8-Kbyte D-cache	<input type="radio"/>	
	ARM946E-S	ARM9E + PU + I-cache (configurable) + D-cache (configurable) + TCM (configurable)		<input type="radio"/>
	ARM926EJ-S	ARM9E + MMU + I-cache (configurable) + D-cache (configurable) + TCM (configurable) + Java		<input type="radio"/>

### Peripherals

IP	Macro	Function	Data type	
			Hard	Soft
<b>Bus Interface</b>				
PCMCIA	PCMCIA1	PCMCIA PC card interface		<input type="radio"/>
	82365SL	PCMCIA card interface controller		<input type="radio"/>
IEEE1284	1284	IEEE 1284 host parallel port		<input type="radio"/>
I2C	I2C	I <sup>2</sup> C bus interface		<input type="radio"/>
FDD-cntl	FDC78	High performance PC compatible floppy disk controller system (82078SL)		<input type="radio"/>
	765A78	Extended features floppy disk controller core for FM and MFM formats		<input type="radio"/>
<b>Microcontroller &amp; Microprocessor</b>				
8-bit-cntl	8051	High performance industry compatible 8-bit microcontroller with 2 timers		<input type="radio"/>
<b>Microprocessor Peripheral</b>				
SDRAMC		Synchronous DRAM Controller		<input type="radio"/>
DMA	8237A	General purpose programmable 4-channel DMA controller		<input type="radio"/>
LCDC		Color LCD Controller (TFT, HR-TFT, CSTN, STN, DMTN)		<input type="radio"/>
PIT	8254	Extended feature 3-channel Programmable Interval Timer (PIT)		<input type="radio"/>
RTC	146818	Ultra-low-power real time clock with up to 114 bytes of RAM		<input type="radio"/>
PIC	8259A	8-channel cascadable Programmable Interrupt Controller (PIC)		<input type="radio"/>
PPI	8255	General purpose Programmable Peripheral Interface (PPI)		<input type="radio"/>
INTC		Interrupt Controller		<input type="radio"/>
<b>Serial Communication</b>				
USB-OTG		Universal Serial Bus On The Go Controller Full Speed (12 MHz)/ Low Speed (1.5 MHz)/High Speed (480 MHz)		<input type="radio"/>
USART	8251A	Universal Synchronous/Asynchronous Receiver/Transmitter (USART)		<input type="radio"/>
SSP		Synchronous Serial Port		<input type="radio"/>
SCC	85C30	SCC 2-channel Serial Communications Controller with FIFOs		<input type="radio"/>
UART	16550A	Universal Asynchronous Receiver/Transmitter (UART) with FIFO		<input type="radio"/>
	6402	Compact Universal Asynchronous Receiver/Transmitter (UART)		<input type="radio"/>

### Analog Cells

IP	Macro	Function	Data type	
			Hard	Soft
ADC	High Speed ADC	8-bit AD (80 MHz), 10-bit AD (80 MHz), 6-bit AD (80 MHz)	<input type="radio"/>	
	Voice ADC	12-bit AD/14-bit AD (8 to 32 kHz)	<input type="radio"/>	
	Audio ADC	20-bit AD (44.1 kHz)	<input type="radio"/>	
DAC	High Speed DAC	8-bit DA/9-bit DA (30 MHz)	<input type="radio"/>	
	Voice DAC	10-bit DA (8 to 32 kHz)	<input type="radio"/>	
	Audio DAC	20-bit DA (44.1 kHz)	<input type="radio"/>	

### Analog PLL (Phase Locked Loop)

IP	Macro	Function	Data type	
			Hard	Soft
PLL	PLL	Fout : 100 to 200 MHz	<input type="radio"/>	
		Fout : 200 to 400 MHz	<input type="radio"/>	
		Fout : 400 to 800 MHz	<input type="radio"/>	
		Fin : 32 kHz, Fout : 33 to 134 MHz	<input type="radio"/>	

### Others

IP	Macro	Function	Data type	
			Hard	Soft
LVDS	LVDS Receiver	Input signal : 7-bit 3 ch (6 bits for RGB), 85 MHz (MAX.)	<input type="radio"/>	
		Input signal : 7-bit 4 ch (8 bits for RGB), 85 MHz (MAX.)	<input type="radio"/>	
RSDS	RSDS Transmitter	Input signal : 8 bits for RGB, 90 MHz (MAX.)	<input type="radio"/>	

Contact a SHARP sales office about applicable series. A use-fee and license-fee are required for use of the above IPs.

# Smart Card Systems

<b>Smart Cards/ LSI Modules for Smart Cards</b>	<b>24</b>
<b>Reader/Writer for Smart Cards</b>	<b>25</b>
<b>Software Development Kit for Smart Cards</b>	<b>25</b>

# Smart Card Systems

## Smart Cards/LSI Modules for Smart Cards

Type		Communication standards	Protocol	Transmission speed (kbps) MAX.	Nonvolatile memory capacity	Cycling capability	CPU	Security system
SJCard 211	Contact	ISO/IEC7816	T = 1	19.2	1 Mbyte (Flash memory)	100 000 times	16 bits	RSA, DES, T-DES, etc. high-speed cryptographic authentication with built-in coprocessor, hardware-based random number generator
	Contactless	ISO/IEC14443 Type B	ISO/IEC14443-4	424				
★JCOP*	Contact	ISO/IEC7816	T = 0, 1	76.8	1 Mbyte (Flash memory)	100 000 times	16 bits	(Under development)
	Contactless	ISO/IEC14443 Type B	ISO/IEC14443-4	424				
(Under development)	Contact	ISO/IEC7816	T = 0, 1	76.8	1 Mbyte (Flash memory)	100 000 times	32-bit MIPS	(Under development)
	Contactless	ISO/IEC14443 Type B	ISO/IEC14443-4	424				



SJCard 211

- Java Card™ 2.1.1 compliance
- Capable of developing applications using Java language



★JCOP\* card

- Java Card™ 2.2 compliance
- GP (Global Platform) 2.1.1 compliance
- EMV 2000 compliance
- With built-in USIM interface
- Capable of developing applications using Java language



★32-bit MIPS card

- With built-in 32-bit MIPS on CPU
- High security thanks to incorporation of secure MIPS32™ 4KSd™ controller

\*JCOP : JCOP means IBM's Java Card Open Platform, which was developed by IBM Corporation as an embedded Operating System (OS) for smart cards which conforms to the standards of Java and Global Platform. This platform ensures the security of applications working on various mobile terminals, such as a USB key and a smart card suitable for multiple applications.

CMOS Image Sensors/ CCDs  
LSIs for LCDs  
System LSIs  
Smart Card Systems  
Flash Memories/ Combination Memories  
Power Devices/ Analog ICs  
Packages  
Index (Model No.)

### Reader/Writer for Smart Cards

Type	Model No.	Communication standard	Host interface	Transmission speed between smart card and RW (kbps)	Smart card operation method	Outline dimensions W x H x D (mm)	Mass (g)	Power supply
Contact type	RW4040	ISO/IEC7816 (T = 0, 1)	USB1.1 (Included driver soft)	9.6 to 153.6	Manual insertion/ejection	70.4 x 14.1 x 60.5	Approx. 65	DC 5 V (USB connector)
	LR550R03	ISO/IEC7816 (T = 0, 1)	PC card interface Type II	10.8 to 344.1		54 x 5 x 85.6	Approx. 30	DC 5 V (PC card connector)



Contact type reader/writer (RW4040)  
 • High-speed data communication  
 • Conforms to PC/SC standard  
 • USB interface



Contact type reader/writer (LR550R03)  
 • High-speed data communication  
 • PC card interface Type II

### SDK (Software Development Kit) for Smart Cards

SDK type	Contents
For SJCard 211	Development kit CD for SJCard SJCard simulator Contact type reader/writer (1 set)

CMOS Image Sensors/  
CCDs

LSIs for LCDs

System LSIs

Smart Card Systems

Flash Memories/  
Combination Memories

Power Devices/  
Analog ICs

Packages

Index  
(Model No.)

# Flash Memories/ Combination Memories

## Flash Memories

### [Highly Functional Type]

Boot Block Type 3 V Page Mode **27, 29**

### [Standard Type]

Boot Block Type 3 V **27, 29**

## System-Flash

For PCs **28, 30**

For Digital Equipment **28, 30**

For Amusement Products **28, 30**

## Combination Memories

Boot Block Type Flash Memory +  
Pseudo SRAM **31**



## Flash Memories

## Highly Functional Flash Memories

## Boot Block Type 3 V Page Mode Flash Memories : LH28FXXXBF Series

Capacity (bit)	Bit configuration	Erasable block size		Operating temp. (°C)	Model No.	Remarks
32 M	x 16	4 Kwords x 8, 32 Kwords x 63	Top boot	0 to 70	LH28F320BF-PTTL	<ul style="list-style-type: none"> <li>Built-in dual work function</li> <li>Built-in OTP function [4 words (factory area) + 4 words (user area) ]</li> </ul>
				-40 to 85	LH28F320BFH-PTTL	
			Bottom boot	0 to 70	LH28F320BF-PBTL	
				-40 to 85	LH28F320BFH-PBTL	
64 M	x 16	4 Kwords x 8, 32 Kwords x 127	Top boot	0 to 70	LH28F640BF-PTTL	
				-40 to 85	LH28F640BFH-PTTL	
			Bottom boot	0 to 70	LH28F640BF-PBTL	
				-40 to 85	LH28F640BFH-PBTL	
128 M	x 16	4 Kwords x 8, 32 Kwords x 255	Top boot	0 to 70	LH28F128BF-PTTL	
				-40 to 85	LH28F128BFH-PTTL	
			Bottom boot	0 to 70	LH28F128BF-PBTL	
				-40 to 85	LH28F128BFH-PBTL	

## Standard Flash Memories

## Boot Block Type 3 V Flash Memories : LH28FXXXBJ Series

Capacity (bit)	Bit configuration	Erasable block size		Operating temp. (°C)	Model No.	Remarks
8 M	x 8	8 Kbytes x 8, 64 Kbytes x 15	Top boot	0 to 70	LH28F008BJ-TTL	-
			Bottom boot	0 to 70	LH28F008BJ-BTL	
	x 8/ x 16	4 Kwords x 8, 32 Kwords x 15 (or 8 Kbytes x 8, 64 Kbytes x 15)	Top boot	0 to 70	LH28F800BJ-PTTL	<ul style="list-style-type: none"> <li>Built-in OTP function [4 words (factory area) + 3 963 words (user area) ]</li> </ul>
				-40 to 85	LH28F800BJH-PTTL	
			Bottom boot	0 to 70	LH28F800BJ-PBTL	
				-40 to 85	LH28F800BJH-43	
LH28F800BJH-PBTL						
16 M	x 8/ x 16	4 Kwords x 8, 32 Kwords x 31 (or 8 Kbytes x 8, 64 Kbytes x 31)	Top boot	-40 to 85	LH28F160BJH-PTTL	-
			Bottom boot	-40 to 85	LH28F160BJH-PBTL	

## System-Flash

### FWH\* Interface System-Flash for PCs

Capacity (bit)	Bit configuration	Erasable block size		Operating temp. (°C)	Model No.
8 M	x 8	8 Kbytes x 8, 64 Kbytes x 15	Top boot	0 to 85	LHF00L04
			Symmetrical block	0 to 85	LHF00L21

\* FWH : Firmware Hub

### Fast-Reprogramming System-Flash for Digital Equipment

Capacity (bit)	Bit configuration	Erasable block size		Operating temp. (°C)	Model No.	Remarks
16 M	x 16	4 Kwords x 8 + 32 Kwords x 1, 64 Kwords x 15	Top boot	-40 to 85	LHF00L24	<ul style="list-style-type: none"> <li>Fast-reprogramming (4-Kword blocks)</li> <li>Built-in OTP function [4 words (factory area) + 4 words (user area)]</li> </ul>
			Bottom boot	-40 to 85	LHF00L28	
					LHF00L25	
					LHF00L29	
32 M	x 16	4 Kwords x 8 + 32 Kwords x 1, 64 Kwords x 31	Top boot	-40 to 85	LHF00L08	
					LHF00L10	
					LHF00L14	
			Bottom boot	-40 to 85	LHF00L09	
					LHF00L11	
					LHF00L15	

### System-Flash for Amusement Products

Capacity (bit)	Bit configuration	Erasable block size		Operating temp. (°C)	Model No.	Remarks
256 M	x 16	16 Kwords x 4, 64 Kwords x 255	Top boot	0 to 85	LH28F256BF-PTSL	• 70 SSOP industry standard package
512 M	x 16	(16 Kwords x 4, 64 Kwords x 255) x 2	Top/Top boot	0 to 70	LH28F512BF-PTSL	• Compact FBGA (CSP) package

## Highly Functional Flash Memories

### Boot Block Type 3 V Page Mode Flash Memories : LH28FXXXBF Series

Supply voltage		32 M : $V_{CC} = 2.7$ to $3.6$ V, $V_{PP} = 2.7$ to $3.6$ V or $11.7$ to $12.3$ V 64 M : $V_{CC} = 2.7$ to $3.6$ V, $V_{PP} = 1.65$ to $3.6$ V or $9.0$ to $10.0$ V 128 M : $V_{CC} = 2.7$ to $3.6$ V, $V_{PP} = 2.7$ to $3.6$ V or $9.0$ to $10.0$ V														
Capacity (bit)	Bit configuration	Erasable block size	Model No.	Access time (ns) MAX.	Page mode access time (ns) MAX.	Read current (mA) MAX. $f = 5$ MHz (CMOS)	Standby current ( $\mu$ A) MAX. (CMOS)	Operating temp. ( $^{\circ}$ C)	Package							
32 M	x 16	Parameter : 4 Kwords x 8 Main : 32 Kwords x 63	Top boot	LH28F320BFE/B-PTTL70	70	25	25	20	0 to 70 -40 to 85	P-TSOP048-1220 (Normal bend)/ TFBGA048-0808						
			Bottom boot	LH28F320BFHE/B-PTTL70												
			64 M	x 16	Parameter : 4 Kwords x 8 Main : 32 Kwords x 127	Top boot	LH28F320BFHG-PTTLZK	80	35	25	20	0 to 70 -40 to 85	TFBGA048-0707			
						Bottom boot	LH28F320BFE/B-PBTL70	70	25							
						128 M	x 16	Parameter : 4 Kwords x 8 Main : 32 Kwords x 255	Top boot	LH28F320BFHE/B-PBTL70	70	25	25	20	0 to 70 -40 to 85	P-TSOP048-1220 (Normal bend)/ TFBGA048-0808
									Bottom boot	LH28F320BFHG-PBTLZL	80	35				
64 M	x 16	Parameter : 4 Kwords x 8 Main : 32 Kwords x 127	Top boot	LH28F640BFE-PTTLHDA	70	30	25	20	0 to 70 -40 to 85	P-TSOP048-1220 (Normal bend)/ TFBGA060-0811						
			Bottom boot	LH28F640BFB-PTTL70A												
			Top boot	LH28F640BFHE-PTTLHFA												
			Bottom boot	LH28F640BFHB-PTTL70A												
			128 M	x 16	Parameter : 4 Kwords x 8 Main : 32 Kwords x 255	Top boot	LH28F640BFE-PBTLHEA	70	30	25	20	0 to 70 -40 to 85	P-TSOP048-1220 (Normal bend)/ TFBGA060-0811			
						Bottom boot	LH28F640BFB-PBTL70A									
						Top boot	LH28F640BFHE-PBTLHGA	70	30	25	20	0 to 70 -40 to 85	P-TSOP048-1220 (Normal bend)/ TFBGA060-0811			
						Bottom boot	LH28F640BFHB-PBTL70A									
128 M	x 16	Parameter : 4 Kwords x 8 Main : 32 Kwords x 255	Top boot	LH28F128BFT/B-PTTL75A	75	25	35	40	0 to 70 -40 to 85	P-TSOP056-1420 (Normal bend)/ LFBGA072-0811						
			Bottom boot	LH28F128BFHT/B-PTTL75A												
			Top boot	LH28F128BFT/B-PBTL75A	75	25	35	40	0 to 70 -40 to 85	P-TSOP056-1420 (Normal bend)/ LFBGA072-0811						
			Bottom boot	LH28F128BFHT/B-PBTL75A												

Contact a SHARP sales office for other packages and top boot/bottom boot models other than those listed above.

## Standard Flash Memories

### Boot Block Type 3 V Flash Memories : LH28FXXXBJ Series

Supply voltage		$V_{CC} = 2.7$ to $3.6$ V, $V_{CCW} = 2.7$ to $3.6$ V or $11.7$ to $12.3$ V								
Capacity (bit)	Bit configuration	Erasable block size	Model No.	Access time (ns) MAX.	Read current (mA) MAX. $f = 5$ MHz (CMOS)	Standby current ( $\mu$ A) MAX. (CMOS)	Operating temp. ( $^{\circ}$ C)	Package		
8 M	x 8	Boot : 8 Kbytes x 2 Parameter : 8 Kbytes x 6 Main : 64 Kbytes x 15	Top boot	LH28F008BJT-TTLZ2	100	25	15	0 to 70	P-TSOP040-1020 (Normal bend)	
			Bottom boot	LH28F008BJT-BTLZ1	100	25	15	0 to 70		
	x 8/ x 16	Boot : 4 Kwords (8 Kbytes) x 2 Parameter : 4 Kwords (8 Kbytes) x 6 Main : 32 Kwords (64 Kbytes) x 15	Top boot	LH28F800BJE-PTTL90	90	25	15	0 to 70 -40 to 85	P-TSOP048-1220 (Normal bend)	
			Bottom boot	LH28F800BJE-PTTL90						
			Top boot	LH28F800BJE-PBTL70	70 (At 2.97 to 3.63 V)	25	15	0 to 70		
			Bottom boot	LH28F800BJE-PBTL90						
			Top boot	LH28F800BJHB-43	90	25	15	-40 to 85		TFBGA048-0608
			Bottom boot	LH28F800BJHE-PBTL90						P-TSOP048-1220 (Normal bend)
	16 M	x 8/ x 16	Boot : 4 Kwords (8 Kbytes) x 2 Parameter : 4 Kwords (8 Kbytes) x 6 Main : 32 Kwords (64 Kbytes) x 31	Top boot	LH28F160BJHE-PTTL70	70	25	15	-40 to 85	P-TSOP048-1220 (Normal bend)
				Bottom boot	LH28F160BJHE-PBTL70	70	25	15	-40 to 85	

Contact a SHARP sales office for other packages and top boot/bottom boot models other than those listed above.

## System-Flash

### FWH\* Interface System-Flash for PCs

Supply voltage		V <sub>CC</sub> = 3.0 to 3.6 V							
Capacity (bit)	Bit configuration	Erasable block size		Model No.	Operating frequency (MHz)	Read current (mA) MAX. f = 33 MHz (CMOS)	Standby current (μA) MAX. (CMOS)	Operating temp. (°C)	Package
8 M	x 8	Boot : 8 Kbytes x 8	Top boot	LHF00L04	33	15	15	0 to 85	P-TSOP040-1020 (Normal bend)
		Main : 64 Kbytes x 15	Symmetrical block	LHF00L21	33	15	15	0 to 85	P-TSOP032-0813 (Normal bend)
		64 Kbytes x 16							

\* FWH : Firmware Hub

Contact a SHARP sales office for other packages and top boot/bottom boot models other than those listed above.

### Fast-Reprogramming System-Flash for Digital Equipment

Supply voltage		V <sub>CC</sub> = 2.7 to 3.6 V, V <sub>PP</sub> = 11.7 to 12.3 V								
Capacity (bit)	Bit configuration	Erasable block size		Model No.	Access time (ns) MAX.	4-Keyword reprogramming time (s)	Read current (mA) MAX. f = 5 MHz (CMOS)	Standby current (μA) MAX. (CMOS)	Operating temp. (°C)	Package
16 M	x 16	Parameter : 4 Kwords x 8 + 32 Kwords x 1 Main : 64 Kwords x 15	Top boot	LHF00L24	70	0.31	17	10	-40 to 85	TFBGA048-0608
				LHF00L28						P-TSOP048-1220 (Normal bend)
		Bottom boot	LHF00L25	70	0.31	17	10	-40 to 85	TFBGA048-0608	
			LHF00L29						P-TSOP048-1220 (Normal bend)	
32 M	x 16	Parameter : 4 Kwords x 8 + 32 Kwords x 1 Main : 64 Kwords x 31	Top boot	LHF00L08	90	0.31	17	10	-40 to 85	TFBGA048-0608
				LHF00L10						TFBGA048-0707
				LHF00L14						P-TSOP048-1220 (Normal bend)
			Bottom boot	LHF00L09	90	0.31	17	10	-40 to 85	TFBGA048-0608
				LHF00L11						TFBGA048-0707
				LHF00L15						P-TSOP048-1220 (Normal bend)

Contact a SHARP sales office for other packages and top boot/bottom boot models other than those listed above.

### System-Flash for Amusement Products

Supply voltage		V <sub>CC</sub> = 1.7 to 1.95 V, V <sub>CCQ</sub> = 2.7 to 3.6 V, V <sub>PP</sub> = 0.9 to 1.95 V or 8.5 to 9.5 V								
Capacity (bit)	Bit configuration	Erasable block size		Model No.	Access time (ns) MAX.	Page mode access time (ns) MAX.	Read current (mA) MAX. f = 5 MHz (CMOS)	Standby current (μA) MAX. (CMOS)	Operating temp. (°C)	Package
256 M	x 16	Parameter : 16 Kwords x 4 Main : 64 Kwords x 255	Top boot	LH28F256BFN-PTSLZ2	100	25	22	60	0 to 85	P-SSOP070-0500
512 M	x 16	(Parameter : 16 Kwords x 4 Main : 64 Kwords x 255) x 2	Top/Top boot	LH28F512BFBD-PTSLZ2	90	25	22	120	0 to 70	LFBGA072-0811

Contact a SHARP sales office for other packages and top boot/bottom boot models other than those listed above.



# Combination Memories

## ■ Boot Block Type Flash Memory + Pseudo SRAM

### ● 1.8 V models with 1.8 V I/O voltage

Model No.	Flash memory block configuration	Capacity (bit) [Bit configuration]		Access time (ns) MAX.						Supply voltage (V)			Package
		Flash memory	Pseudo SRAM	Flash memory			Pseudo SRAM			Flash memory core voltage	Pseudo SRAM core voltage	I/O voltage	
				Random mode	Page mode	Synchronous burst mode	Random mode	Page mode	Synchronous burst mode				
LRS18AC	Bottom boot	128 M [x 16]	32 M [x 16]	85	25	54 MHz	70	20	–	1.7 to 1.95	1.7 to 1.95	1.7 to 1.95	LFBGA088-0811
LRS1890A		256 M [x 16]	64 M [x 16]	85	25	–	70	20	–	1.7 to 1.95	1.7 to 1.95	1.7 to 1.95	LFBGA072-0811
LRS1887B			256 M [x 32]			80 MHz			80 MHz				LFBGA107-0912
LRS18A6			128 M [x 16]			–			–				LFBGA072-0811
LRS1897	Bottom/Top boot	512 M [x 16]	128 M [x 16]	85	25	–	70	20	–	1.7 to 1.9	2.7 to 3.1	1.7 to 1.9	LFBGA072-0811
LRS18CC	Bottom/Top/Bottom boot	740 M [x 16]	256 M [x 16]	93	25	52 MHz	70	20	83 MHz	1.7 to 1.95	1.7 to 1.95	1.7 to 1.95	LFBGA088-0912

### ● 1.8 V models with 3 V I/O voltage

Model No.	Flash memory block configuration	Capacity (bit) [Bit configuration]		Access time (ns) MAX.						Supply voltage (V)			Package
		Flash memory	Pseudo SRAM	Flash memory			Pseudo SRAM			Flash memory core voltage	Pseudo SRAM core voltage	I/O voltage	
				Random mode	Page mode	Synchronous burst mode	Random mode	Page mode	Synchronous burst mode				
LRS18BK	Top boot	128 M [x 16]	32 M [x 16]	85	25	54 MHz	65	20	–	1.7 to 1.95	2.7 to 3.1	2.7 to 3.1	LFBGA088-0811
LRS18BL	Bottom boot					–							LFBGA072-0811
LRS18C8A						54 MHz							LFBGA088-0811
LRS18BN	64 M [x 16]		54 MHz	LFBGA088-0811									
LRS18AZ*	Bottom boot	256 M [x 16]	64 M [x 16]	85	25	54 MHz	65	20	–	1.7 to 1.95	2.7 to 3.1	2.7 to 3.1	LFBGA088-0811
LRS18B0*						–							LFBGA072-0811

\* This flash memory is divided into two banks, each including an enable signal.

### ● 3 V models with 3 V I/O voltage

Model No.	Flash memory block configuration	Capacity (bit) [Bit configuration]		Access time (ns) MAX.						Supply voltage (V)			Package									
		Flash memory	Pseudo SRAM	Flash memory			Pseudo SRAM			Flash memory core voltage	Pseudo SRAM core voltage	I/O voltage										
				Random mode	Page mode	Synchronous burst mode	Random mode	Page mode	Synchronous burst mode													
LRS18BT	Bottom boot	32 M [x 16]	8 M [x 16]	85	–	–	85	–	–	2.7 to 3.1	2.7 to 3.1	2.7 to 3.1	LFBGA072-0811									
LRS1871A	Top boot	64 M [x 16]	16 M [x 16]	85	35	–	85	–	–	2.7 to 3.3	2.7 to 3.1	2.7 to 3.1	LFBGA072-0811									
LRS1872A	Bottom boot												LFBGA072-0811									
LRS18BP	Top boot		32 M [x 16]	65	25	–	65	20	–	2.7 to 3.1	2.7 to 3.1	2.7 to 3.1	LFBGA088-0811									
LRS18BR	Bottom boot												LFBGA088-0811									
LRS18831	Top boot												70	35	–	60	–	–	2.7 to 3.1	2.7 to 3.1	–	LFBGA072-0811
LRS18841	Bottom boot																					LFBGA072-0811

# Power Devices/ Analog ICs

## Power Devices

Low Power-loss Voltage Regulators	33
Surface Mount Type Low Power-loss Voltage Regulators	35
Surface Mount Type Chopper Regulators (DC-DC Converters)	38
Chopper Regulators (DC-DC Converters)	39
Power Supply ICs for CCDs/CCD Camera Modules	40
Power Supply ICs for TFT-LCDs	40
LED Drivers	41

## Analog ICs

Video Interface ICs for TFT-LCDs	42
Power Amplifiers for Wireless LAN	43
Power Amplifier for Cordless Phones	43
Laser Diode Drivers	44
IC for Cameras	44
Compandor	44
ICs for Audio Equipment	44



# Power Devices

## Low Power-loss Voltage Regulators

TO-220 type

(Ta = 25°C)

Model No.	Features	Absolute maximum ratings				Electrical characteristics			Built-in functions						Package		
		Output current I <sub>o</sub> (A)	Input voltage V <sub>in</sub> (V)	Power dissipation (W)		Output voltage V <sub>o</sub> *3 (V) TYP.	Output voltage precision (%)	Dropout voltage V <sub>i-o</sub> *5 (V)	Overheat protection	Overcurrent protection	ON/OFF control	Low dissipation current at OFF state	Variable output voltage	Lead forming available		Package shape type*7	
				Pd*1	Pd*2												
PQxxRD08J00H series	ASO protection function	0.8	20	1.25	10	5, 9, 12	±3	0.5	○	○	○	○	○	○	○	A	
PQ3RD083J00H						3.3											
PQ6RD083J00H						6.3											
PQxxRA11J00H series	Low dissipation current at OFF state (I <sub>qs</sub> : 1μA (MAX.))	1	20	1.4	15	5, 9, 12	±2.5	0.5	○	○	○	○	○	○	○	B	
PQxxRD11J00H series	ASO protection function					24											
PQxxxRDA1SZH series	ASO protection function, low dissipation current at OFF state (I <sub>qs</sub> : 5 μA (MAX.))					2											
PQxxxRDA2SZH series	ASO protection function, low dissipation current at OFF state (I <sub>qs</sub> : 5 μA (MAX.))	2	20	-	-	3.3, 5, 9, 12	±2.5	0.5	○	○	○	○	○	○	○	A	
PQ3RD13J000H	ASO protection function					1											
PQxxxEF01SZH series	Minimum operating input voltage : 2.35 V (4 terminals)					2											
PQxxxEF02SZH series	Minimum operating input voltage : 2.35 V (4 terminals)	1	35	1.5	18	5, 9, 12	±2.5	0.5	○	○	○	○	○	○	○	B	
PQxxRF11J00H series	General purpose					1.5											
PQxxRH11J00H series	General purpose					1.5											
PQ3RD23J000H	ASO protection function	2	20	1.4	15	3.3	±3	0.5	○	○	○	○	○	○	○	A	
PQxxRD21J00H series						ASO protection function											35
PQxxRF21J00H series						General purpose											35
PQ3RF23J000H	High output current	3.5	18	1.8	3.3	3.3	±2.5	0.5	○	○	○	○	○	○	○	B	
PQ3RF33J000H						High output current											18
PQ070XF01SZH						Minimum operating input voltage : 2.35 V (4 terminals)											1
PQ070XF02SZH	Minimum operating input voltage : 2.35 V (4 terminals)	2	10	1.4	15	1.5 to 7	±2*4	0.5	○	○	○	○	○	○	○	A	
PQ070VK01FZH	Minimum operating input voltage : 2.35 V (5 terminals)					1											
PQ070VK02FZH	Minimum operating input voltage : 2.35 V (5 terminals)					2											
PQ15RW08J00H	ASO protection function, minimum operating input voltage : 3.5 V	0.8	20	1.25	10	3.0 to 15	±2.5*4	0.5	○	○	○	○	○	○	○	A	
PQ15RW11J00H						ASO protection function, minimum operating input voltage : 3.5 V											1
PQ15RW21J00H						ASO protection function, minimum operating input voltage : 3.5 V											2
PQ150RWA2SZH	ASO protection function	0.5	24	1.25	10	3.0 to 20	±2.5*4	0.5	○	○	○	○	○	○	○	C	
PQ20RX05J00H	Variable output voltage, output ON/OFF control					10											
PQ20RX11J00H	Variable output voltage, output ON/OFF control					10											
PQ150VB01FZH	Overheat shutdown circuit, minimum operating input voltage : 2.35 V (5 terminals)	1	17	12.5	12.5	1.5 to 15	±2*4	0.5	○	○	○	○	○	○	○	E	
PQ150VB02FZH						Overheat shutdown circuit, minimum operating input voltage : 2.35 V (5 terminals)											17
PQ30RV11J00H	Variable output voltage	1	35	1.5	15	1.5 to 30	±2*4	0.5	○	○	△*6	○	○	○	○	B	
PQ30RV21J00H						Variable output voltage											15
PQ30RV31J00H						Variable output voltage											20
PQ7RV4J0000H						Variable output voltage											20
PQ7RV4J0000H	Variable output voltage	4.6	10	1.8	18	1.5 to 7	±2*4	0.5	○	○	△*6	○	○	○	○	B	

\*1 At self-cooling  
 \*2 With infinite heat sink attached  
 \*3 The xx/xxx in the model No. refer to the output voltage values of the model (e.g. 05/050 for 5 V, 12/120 for 12 V, 015 for 1.5 V).  
 \*4 Reference voltage accuracy  
 \*5 Current ratings are defined individually.  
 \*6 △ : Available by adding circuit  
 \*7 Refer to page 55

CMOS Image Sensors/  
CCDs  
LSIs for LCDs  
System LSIs  
Smart Card Systems  
Flash Memories/  
Combination Memories  
Power Devices/  
Analog ICs  
Packages  
Index  
(Model No.)

### ● High output current type [TO-220 high heat radiation type, TO-3P type]

(Ta = 25°C)

Model No.	Features	Absolute maximum ratings				Electrical characteristics			Built-in functions				Package
		Output current I <sub>o</sub> (A)	Input voltage V <sub>in</sub> (V)	Power dissipation (W)		Output voltage V <sub>o</sub> (V)	Output voltage precision (%)	Dropout voltage V <sub>i-o</sub> *4 (V)	Overheat protection	Overcurrent protection	ON/OFF control	Variable output voltage	
				Pd*1	Pd*2								
PQ5EV3J0000H	High output current, minimum operating input voltage : 2.35 V	3.5	7	1.6	45	1.5 to 5	±1*3	0.5	○	○	○	○	TO-220 (heat sink exposure)
PQ5EV5J0000H		5							○	○	○	○	
PQ5EV7J0000H		7.5							○	○	○	○	
PQ7DV5J0000H	High output current, minimum operating input voltage : 3 V	5	10	2.2	60	1.5 to 7	±2*3	○	○	○	○	TO-3P	
PQ7DV10J0000H		10						○	○	○	○		

\*1 At self-cooling

\*2 With infinite heat sink attached

\*3 Reference voltage accuracy

\*4 Current ratings are defined individually.

### ● Low output current type [TO-92 type]

(Ta = 25°C)

Model No.	Features	Absolute maximum ratings			Electrical characteristics			Built-in functions		Package
		Output current I <sub>o</sub> (A)	Input voltage V <sub>in</sub> (V)	Power dissipation Pd*1 (W)	Output voltage V <sub>o</sub> (V) TYP.	Output voltage precision (%)	Dropout voltage V <sub>i-o</sub> (V)	Overheat protection	Overcurrent protection	
PQ033ES1MXPQ	Low output current type with general purpose TO-92 package (for auxiliary power supply)	0.15	16	0.52	3.3	±2	0.4 (I <sub>o</sub> = 150 mA)	○	○	TO-92
PQ050ES1MXPQ					5					
PQ033ES3MXPQ		0.3	9		3.3		0.7 (I <sub>o</sub> = 300 mA)	○	○	
PQ050ES3MXPQ					5					

\*1 At self-cooling

## ■ Surface Mount Type Low Power-loss Voltage Regulators

### ● SOT-23-5 type

(Ta = 25°C)

Model No.	Features	Absolute maximum ratings			Electrical characteristics			Built-in functions				Package
		Input voltage Vin (V)	Power dissipation Pd*1 (W)	Output current Io (A)	Output voltage Vo*2 (V) TYP.	Output voltage precision (%)	Dropout voltage Vi-o (V)	Overheat protection	Overcurrent protection	ON/OFF control	Low dissipation current at OFF state	
<b>PQ1Uxx1M2ZPH series</b>	Compact, low output current	16	0.35	0.18	1.8, 2.5, 2.8, 3.0, 3.3, 3.5, 5.0	± 2.0 (3.0 V output)	0.26 (Io = 60 mA)	○	○	○	○	SOT-23-5
<b>PQ1Xxx1M2ZPH series</b>	Compact, ceramic capacitor compatible	9			*3			○	○	○	○	

\*1 When mounted on a board

\*2 The xx in the model No. refer to the output voltage values of the model (e.g. 50 for 5.0 V, 18 for 1.8 V).

\*3 1.5, 1.8, 2.5, 2.6, 2.7, 2.8, 2.9, 3.0, 3.3, 3.5, 3.7, 4.0, 4.5, 5.0

### ● SOT-23L type

(Ta = 25°C)

Model No.	Features	Absolute maximum ratings			Electrical characteristics				Built-in functions				Package
		Output current Io (A)	Input voltage Vin (V)	Power dissipation Pd*1 (W)	Output current Io (A)	Output voltage Vo*2 (V) TYP.	Output voltage precision (%)	Dropout voltage Vi-o (V)	Overheat protection	Overcurrent protection	ON/OFF control	Low dissipation current at OFF state	
<b>PQ1RxxJ0000H series</b>	Compact, surface mount type, low dissipation current at OFF state (Iqs : 0.1 μA (MAX.))	-	16	0.4	0.18	*3	± 2.7 (3.0 V output)	0.26 (Io = 60 mA)	○	○	○	○	SOT-23L
<b>PQ1Kxx3M2ZPH series</b>	Compact, surface mount type, high ripple rejection, output current of up to 300 mA	0.3	9		-	1.8, 2.5, 3.0, 3.3, 3.6, 5.0	± 2.0 (3.0 V output)	0.7 (Io = 300 mA)	○	○	○	○	
<b>PQ1KAXx3MZPH series</b>	Compact, surface mount type, output current of up to 300 mA, ceramic capacitor compatible		15	-	1.5, 1.8, 2.5, 3.3, 5.0, 9.0	○			○	○	○		

\*1 When mounted on a board

\*2 The xx in the model No. refer to the output voltage values of the model (e.g. 25 for 2.5 V, 47 for 4.7 V, 50 for 5.0 V).

\*3 1.8, 2.0, 2.3, 2.5, 2.7, 2.8, 2.9, 3.0, 3.2, 3.3, 3.4, 3.5, 3.7, 3.8, 4.0, 4.2, 4.4, 4.7, 4.9, 5.0, 5.2

### ● SOT-89 type

(Ta = 25°C)

Model No.	Features	Absolute maximum ratings			Electrical characteristics			Built-in functions					Package
		Output current Io (A)	Input voltage Vin (V)	Power dissipation Pd*1 (W)	Output voltage Vo*2 (V) TYP.	Output voltage precision (%)	Dropout voltage Vi-o*3 (V)	Overheat protection	Overcurrent protection	ON/OFF control	Low dissipation current at OFF state	Variable output voltage	
<b>PQ1Lxx3M2SPQ</b>	Compact, high radiation package, low dissipation current at OFF state (Iqs : 1 μA (MAX.))	0.3	16	0.9	1.5, 1.8, 2.5, 3.0, 3.2, 3.3, 5.0	± 2.0 (3.0 V output)	0.7	○	○	○	○	SOT-89	
<b>PQ1LAXx3MSPQ</b>	Compact, high radiation package, low dissipation current at OFF state (Iqs : 1 μA (MAX.)), ceramic capacitor compatible		15		1.5, 1.8, 2.5, 3.3, 5.0, 9.0			○	○	○	○		
<b>PQ1LAX95MSPQ</b>	Ceramic capacitor compatible, variable output voltage	0.5	1.5 to 9.0	± 2.0*6	○	○	○	○					
<b>PQ1Mxx5M2SPQ</b>	Compact, high output current, ceramic capacitor compatible	0.5	9	1.8, 2.5, 3.3, 5.0	± 2.0 (5.0 V output)	0.7	○	○	○	○			
<b>PQ1MX55M2SPQ</b>	Ceramic capacitor compatible, variable output voltage			1.3 to 5.0	± 2.0*6		○	○	○	○			
<b>PQ1Nxx3MxSPQ</b>	Reset signal output function*4, ceramic capacitor compatible	0.35	2.5, 3.3	± 2.0	○	○	○	○					
<b>PQ2Lxxx2MSPQ</b>	Compact, high radiation package, 2 outputs	0.25/ch	-	0.4	○	○	○	○					

\*1 When mounted on a board

\*2 The xx in the model No. refer to the output voltage values of the model (e.g. 25 for 2.5 V, 50 for 5.0 V). [Except PQ2Lxxx2MSPQ]

\*3 Current ratings are defined individually.

\*4 Reset detection voltage : 4.2 V, 3.8 V

\*5 Output voltage combination : 3.3/3.3 V, 3.3/2.5 V, 3.3/1.8 V, 3.3/1.5 V, 2.5/1.8 V, 2.5/1.5 V

\*6 Reference voltage accuracy

● SC-63 type

(Ta = 25°C)

Model No.	Features	Absolute maximum ratings			Electrical characteristics			Built-in functions						Package Package shape type <sup>*6</sup>		
		Output current I <sub>o</sub> (A)			Input voltage V <sub>in</sub> (V)	Power dissipation P <sub>d</sub> <sup>*1</sup> (W)	Output voltage V <sub>o</sub> <sup>*2</sup> (V) TYP.	Output voltage precision (%)	Dropout voltage V <sub>i-o</sub> <sup>*5</sup> (V)	Overheat protection	Overcurrent protection	ON/OFF control	Low dissipation current at OFF state		Variable output voltage	Taped package
		0.5	1	1.5												
PQ07VR5MAPH series	Reset signal generation function (input voltage drop detection)	○			10	1.5 to 7	±2.0 <sup>*3</sup>			○	○			○	○	F
PQ3DZ53J000H		○				3.3				○	○	○	○		○	F
PQ3DZ13J000H	ASO protection function, low dissipation current at OFF state (I <sub>qs</sub> : 5 μA (MAX.))		○							○	○	○	○		○	F
PQxxDZ51J00H series		○				5, 9, 12				○	○	○	○		○	F
PQxxDZ11J00H series			○		24					○	○	○	○		○	F
PQxxxDNA1ZPH series	Ceramic capacitor compatible, ASO protection function, low dissipation current at OFF state (I <sub>qs</sub> : 5 μA (MAX.)), solder dip compatible lead shape			○		3.3, 5, 8, 9, 12	±3.0	0.5		○	○	○	○		○	G
PQxxxDZ01ZPH series	Low dissipation current at OFF state (I <sub>qs</sub> : 5 μA (MAX.))			○	9, 10	3.3, 5				○	○	○	○		○	F
PQxxxEZ5MZPH series	Minimum operating input voltage : 2.35 V	○								○	○	○	○		○	F
PQxxxEZ01ZPH series			○			1.5, 1.8, 2.5, 3.0, 3.3	±2.5 <sup>*4</sup>			○	○	○	○		○	F
PQxxxEN01ZPH series	Minimum operating input voltage : 2.35 V, solder dip compatible lead shape			○						○	○	○	○		○	G
PQxxxENA1ZPH series	Minimum operating input voltage : 2.35 V, ceramic capacitor compatible, solder dip compatible lead shape			○	10	1.5, 1.8, 2.5, 3.3	±2.5			○	○	○	○		○	G
PQxxxENAHZPH series				○			—	—		○	○	○	○		○	G
PQxxxEZ1HZPH series	Minimum operating input voltage : 2.35 V			○		1.5, 1.8, 2.5, 3.0, 3.3	±2.5 <sup>*4</sup>	1.0		○	○	○	○		○	F
PQxxxEZ02ZPH series				○ (2 A)		1.5, 1.8, 2.5	±2.5 <sup>*4</sup>	0.5		○	○	○	○		○	F
PQxxxFZ5MZPH series	Minimum operating input voltage : 1.7 V	○			3.7	1.0, 1.2	±30 mV			○	○	○	○		○	F
PQxxxFZ01ZPH series	(Dual power supply type)			○						○	○	○	○		○	F
PQxxxGN01ZPH series	Minimum operating input voltage : 1.7 V (Dual power supply type), ceramic capacitor compatible, solder dip compatible lead shape			○	5.5	0.8, 1.0, 1.2	—	—		○	○	○	○		○	G
PQxxxGN1HZPH series				○						○	○	○	○		○	G
PQ070XZ5MZPH series	Minimum operating input voltage : 2.35 V	○								○	○	○	○		○	F
PQ070XZ01ZPH				○						○	○	○	○		○	F
PQ070XN01ZPH	Minimum operating input voltage : 2.35 V, solder dip compatible lead shape			○			±2.0 <sup>*3</sup>	0.5		○	○	○	○		○	G
PQ070XNA1ZPH	Minimum operating input voltage : 2.35 V, ceramic capacitor compatible, solder dip compatible lead shape			○	10	1.5 to 7				○	○	○	○		○	G
PQ070XNAHZPH				○			—	—		○	○	○	○		○	G
PQ070XZ1HZPH	Minimum operating input voltage : 2.35 V			○			±2.0 <sup>*3</sup>	1.0		○	○	○	○		○	F
PQ070XZ02ZPH				○ (2 A)			±2.0 <sup>*3</sup>	0.5		○	○	○	○		○	F
PQ015YZ5MZPH	Reference voltage (V <sub>ref</sub> ) : 1.0 V, minimum operating input voltage : 1.7 V (Dual power supply type)	○			3.7	1.0 to 1.5	±3.0 <sup>*3</sup>			○	○	○	○		○	F
PQ015YZ01ZPH				○						○	○	○	○		○	F
PQ035ZN01ZPH	Reference voltage (V <sub>ref</sub> ) : 0.6 V, minimum operating input voltage : 1.7 V (Dual power supply type), ceramic capacitor compatible, solder dip compatible lead shape			○	5.5	0.8 to 3.5	±30 mV	—		○	○	○	○		○	G
PQ035ZN1HZPH				○						○	○	○	○		○	G
PQ20VZ51J00H	Minimum operating input voltage : 4.5 V	○				1.5 to 20	±2.0 <sup>*3</sup>			○	○	○	○		○	F
PQ20VZ11J00H				○						○	○	○	○		○	F
PQ20WZ51J00H	Minimum operating input voltage : 3.5 V, ASO protection function, low dissipation current at OFF state (I <sub>qs</sub> : 5 μA (MAX.))	○			24					○	○	○	○		○	F
PQ20WZ11J00H				○						○	○	○	○		○	F
PQ200WNA1ZPH	Minimum operating input voltage : 3.5 V, ASO protection function, low dissipation current at OFF state (I <sub>qs</sub> : 5 μA (MAX.)) ceramic capacitor compatible, solder dip compatible lead shape			○		3.0 to 20	±2.5 <sup>*3</sup>			○	○	○	○		○	G

\*1 With infinite heat sink attached

\*2 The xx/xxx in the model No. refer to the output voltage values of the model (e.g. 033 for 3.3 V, 05/050 for 5 V, 12/120 for 12 V).

\*3 Reference voltage accuracy

\*4 The value is defined as ± 50 mV in some models.

\*5 Current ratings are defined individually.

\*6 Refer to page 56

CMOS Image Sensors/  
CCDs

LSIs for LCDs

System LSIs

Smart Card Systems

Flash Memories/  
Combination Memories

Power Devices/  
Analog ICs

Packages

Index  
(Model No.)

● SOT-263 type

(Ta = 25°C)

Model No.	Features	Absolute maximum ratings			Electrical characteristics			Built-in functions					Taped package	Package	
		Output current I <sub>o</sub> (A)	Input voltage V <sub>in</sub> (V)	Power dissipation P <sub>d</sub> * <sup>1</sup> (W)	Output voltage V <sub>o</sub> * <sup>2</sup> (V) TYP.	Output voltage precision (%)	Dropout voltage V <sub>i-o</sub> * <sup>4</sup> (V)	Overheat protection	Overcurrent protection	ON/OFF control	Low dissipation current at OFF state	Variable output voltage			
PQxxxY053ZPH	High output current (minimum operating input voltage : 2.35 V)	5.0	7	35	1.5, 2.5, 3.3	1.0	0.5	○	○	○	○	○	○	TO-263	
PQ05VY053ZPH					1.5 to 5	1.0* <sup>3</sup>		○	○	○	○	○	○		
PQxxxY3H3ZPH		3.5			1.5, 2.5, 3.3	1.0		○	○	○	○	○	○		
PQ05VY3H3ZPH					1.5 to 5	1.0* <sup>3</sup>		○	○	○	○	○	○		
★PQxxxEHS2ZPH	2 A output (minimum operating input voltage : 2.35 V), built-in soft start function	2.0	10		1.2, 1.5, 1.8, 2.5, 3.3	±2.5		○	○	○	○	○	○		○
PQxxxEH02ZPH	2 A output (minimum operating input voltage : 2.35 V)				1.5, 1.8, 2.5	○		○	○	○	○	○	○		
PQ070XH02ZPH	1 A output (minimum operating input voltage : 2.35 V)	1.5 to 7			±2.0* <sup>3</sup>	○		○	○	○	○	○			
PQxxxEH01ZPH		1.0	1.5, 1.8, 2.5		±2.5	○		○	○	○	○	○			
PQ070XH01ZPH			1.5 to 7	±2.0* <sup>3</sup>	○	○	○	○	○	○					

\*1 With infinite heat sink attached

\*2 The xxx in the model No. refer to the output voltage values of the model (e.g. 015 for 1.5 V, 025 for 2.5 V, 033 for 3.3 V).

\*3 Reference voltage accuracy

\*4 Current ratings are defined individually.

● SOP-8 type

(Ta = 25°C)

Model No.	Features	Absolute maximum ratings			Electrical characteristics		Built-in functions			Taped package	Package
		Output current I <sub>o</sub> (A)	Input voltage V <sub>in</sub> (V)	Power dissipation P <sub>d</sub> * <sup>1</sup> (W)	Output voltage V <sub>o</sub> (V) TYP.	Output voltage precision (mV)	Overheat protection	Overcurrent protection			
★PQ1DX095MZPQ	Built-in sink source function (For DDR II memory)	±0.8	6	0.6	V <sub>DD</sub> x 1/2 (V <sub>DDQ</sub> : 1.5 V (MIN.))	—	○	○	○	SOP-8	
PQ1DX125MZPQ	Built-in sink source function (For DDR memory)				V <sub>DD</sub> x 1/2 (V <sub>DDQ</sub> : 2.3 V (MIN.))	± 35	○	○	○		

\*1 When mounted on a board

### ■ Surface Mount Type Chopper Regulators (DC-DC Converters)

(Ta = 25°C)

Model No.	Features	No. of output circuits	Output type			Built-in SW Tr	Input voltage range Vin (V)	Switch current Isw (A)	Output voltage Vo (V)	Oscillation frequency fo (Hz) TYP.	Package	
			Step-down	Step-up	Inverting							
PQ6CU11X1APQ	<ul style="list-style-type: none"> <li>High voltage CMOS output : 30 V (MAX.)</li> <li>White LED driver for back light</li> <li>Output ON/OFF control function</li> <li>Overvoltage/overcurrent protection circuits</li> <li>Soft start function</li> </ul>	1		○		○	up to 5.5	0.25*1	—	SOT-23-6		
PQ6CB11X1AP	<ul style="list-style-type: none"> <li>High voltage CMOS output : 30 V (MAX.)</li> <li>White LED driver for back light (Capable of driving up to 4 LEDs in series connection)</li> <li>Output ON/OFF control function</li> <li>Overvoltage/overcurrent protection circuits</li> <li>Soft start function</li> </ul>			○		○	2.7 to 5.5		up to 30	1.2 M	USB-6	
PQ6CB11X1CP	<ul style="list-style-type: none"> <li>High voltage CMOS output : 30 V (MAX.)</li> <li>White LED driver for back light (Capable of driving up to 6 LEDs in series connection)</li> <li>Output ON/OFF control function</li> <li>Overvoltage/overcurrent protection circuits</li> <li>Soft start function</li> </ul>			○		○						
PQ6CU12X2APQ	<ul style="list-style-type: none"> <li>High switching voltage : 40 V (MAX.)</li> <li>For tuner power supply</li> <li>Output ON/OFF control function</li> </ul>			○		○	3.0 to 5.5			up to 36	300 k to 800 k*6	SOT-23-6W
★PQ7L2010BP	<ul style="list-style-type: none"> <li>Possible to correspond also to operation in the minute lighting mode</li> <li>High frequency PWM control for brightness adjustment</li> <li>Output ON/OFF control function</li> </ul>			○		○	2.7 to 5.5			up to 30	2 M	USB-10
PQ1CZ38M2ZPH series	<ul style="list-style-type: none"> <li>PWM chopper regulator (high oscillation frequency)</li> <li>Output ON/OFF control function</li> <li>Overcurrent/overheat protection circuits</li> <li>For light load</li> </ul>			○	○	○		0.8*1	VREF*2 to 35*4 (step-down type)/ -VREF*2 to -30*4 (inverting type)	300 k	SC-63	
PQ1CZ21H2ZPH	<ul style="list-style-type: none"> <li>PWM chopper regulator</li> <li>Output ON/OFF control function</li> <li>Overcurrent/overheat protection circuits</li> <li>Low dissipation current at OFF state (Standby current &lt;I<sub>SD</sub>&gt; : 1 μA (MAX.))</li> </ul>			○	○	○	up to 40	1.5*1		100 k		
PQ1CZ41H2ZPH	<ul style="list-style-type: none"> <li>PWM chopper regulator (high oscillation frequency)</li> <li>Output ON/OFF control function</li> <li>Overcurrent/overheat protection circuits</li> </ul>			○	○	○				300 k		
PQ1CX12H2ZPQ	<ul style="list-style-type: none"> <li>Bootstrap system for high efficiency (Efficiency 90% (TYP.))</li> <li>Low dissipation current</li> </ul>			○		○		2.5*1	VREF*3 to 24*4 (step-down type)	150 k	SOP-8	
PQ1CX22H2ZPQ	<ul style="list-style-type: none"> <li>Bootstrap system for high efficiency (Efficiency 90% (TYP.))</li> <li>Low dissipation current</li> <li>Low voltage output : 1.2 V (MIN.)</li> </ul>			○		○	up to 33					
PQ1CY1032ZPH	<ul style="list-style-type: none"> <li>PWM chopper regulator</li> <li>Output ON/OFF control function</li> <li>Overheat protection/overcurrent shutdown circuits</li> <li>High output current type</li> </ul>		○		○		3.5*1	VREF*2 to 35*4 (step-down type)/ -VREF*2 to -30*4 (inverting type)	150 k	TO-263		
PQ1CYxx3HZPH series PQ1CYxx3LZPH series	<ul style="list-style-type: none"> <li>PWM chopper regulator</li> <li>Fixed output voltage : 3.3 V or 5 V</li> <li>Output ON/OFF control function</li> <li>Overheat protection circuit</li> </ul>		○		○	up to 40					3.3, 5.0*5 (TYP.)	
IR3M18N	<ul style="list-style-type: none"> <li>Soft start function</li> <li>Undervoltage protection circuit</li> <li>Timer latch short-circuit protection circuit</li> <li>Standby function</li> </ul>			○		2.2 to 6.0		(Determined by external Tr)	100 k to 1 M*6	P-SSOP008-0150		
IR3M19N	<ul style="list-style-type: none"> <li>High transient load characteristics from built-in current control circuit</li> <li>Soft start function</li> <li>Overcurrent/overvoltage/undervoltage protection circuits</li> <li>Internal reference voltage accuracy (±1%)</li> </ul>		○			4.5 to 22	(Determined by external Tr)	1.24 to input voltage	220 k			
★IR3M56N	<ul style="list-style-type: none"> <li>High efficiency synchronous rectified step-down converter</li> <li>Current mode control</li> <li>Soft start function</li> <li>Overcurrent/overvoltage/undervoltage/overheat protection circuits</li> </ul>		○			4.5 to 36		0.8 to 6.3	200 k/300 k/ 400 k/500 k/ external sync.		P-TSSOP16-0225	
IR3M17U	<ul style="list-style-type: none"> <li>Standby function (output ON/OFF control function for each channel)</li> <li>Soft start function</li> <li>Undervoltage protection circuit</li> </ul>	2		○		2.2 to 6.5		(Determined by external Tr)	100 k to 500 k*6 external sync.		P-HQFN020-0404	

\*1 Peak current (absolute maximum ratings) \*2 VREF nearly equal to 1.26 V (TYP.) \*3 VREF nearly equal to 1 V (TYP.) \*4 Output voltage variable range

\*5 The xx in the model No. refer to the output voltage values of the model (e.g. 33 for 3.3 V, 50 for 5.0 V). \*6 Selectable oscillation frequency range

CMOS Image Sensors/ CCDs  
LSIs for LCDs  
System LSIs  
Smart Card Systems  
Flash Memories/ Combination Memories  
Power Devices/ Analog ICs  
Packages  
Index (Model No.)

### ■ Surface Mount Type Chopper Regulators (DC-DC Converters) (cont'd)

(Ta = 25°C)

Model No.	Features	No. of output circuits	Output type			Built-in SW Tr	Input voltage range Vin (V)	Switch current Isw (A)	Output voltage Vo (V)	Oscillation frequency fo (Hz) TYP.	Package
			Step down	Step up	Inversion						
★PQ5CAD1xxxP series	<ul style="list-style-type: none"> <li>2-ch output (Chopper output + Low-loss regulator)</li> <li>CMOS synchronous rectified step-down converter</li> <li>Independent regulator input terminal</li> <li>Reset circuit</li> <li>Ceramic capacitor compatible</li> </ul>	2	○	○	○	2.9 to 5.5 (4.0 to 5.5 <sup>*2</sup> )	0.8 <sup>*3</sup> (Chopper regulator output) Io : 0.2 (MAX.) (Series regulator output)	1.5, 3.3 <sup>*2</sup> (TYP.)	1.2 M	LNC-8	
★IR3M57N	<ul style="list-style-type: none"> <li>High efficiency two channel synchronous rectified step-down converter</li> <li>Current mode control</li> <li>Soft start function</li> <li>Overcurrent/overvoltage/undervoltage/overheat protection circuits</li> </ul>		○	○	○						External
IR3M30M/U	<ul style="list-style-type: none"> <li>ON/OFF sequence setting</li> <li>Timer latch short-circuit protection circuit</li> <li>Soft start function</li> <li>Overcurrent/undervoltage/overheat protection circuits</li> </ul>	○	○	○	External	2.7 to 5.5	1 <sup>*4</sup> (when using internal Tr) External setting	External setting	70 k to 1M <sup>*5</sup>	P-QFP048-0707/ P-VQFN036-0505	
★IR3M58M/U	<ul style="list-style-type: none"> <li>ON/OFF sequence setting without external control</li> <li>Timer latch phase fault protection circuit</li> <li>Soft start function</li> <li>Overcurrent/undervoltage/overheat protection circuits</li> </ul>	○	○	○							External

\*1 Built-in SW Tr can be used in step-up mode ; external SW Tr is required in step-down or inverting mode.  
 \*2 For model PQ5CAD1B3CP (chopper output voltage : 1.5 V, output voltage of series regulator unit : 3.3 V)  
 \*3 Peak current (absolute maximum ratings)  
 \*4 Constant current (MAX.)  
 \*5 Selectable oscillation frequency range

### ■ Chopper Regulators (DC-DC Converters)

● TO-220 type

(Ta = 25°C)

Model No.	Features	Absolute maximum ratings			Electrical characteristics			Package	
		Switch current Isw (A)	Input voltage Vin (V)	Power dissipation Pd <sup>*1</sup> (W)	Output voltage Vo <sup>*2</sup> (V)	Oscillation frequency fo (kHz) TYP.	Output saturation voltage Vsat (V) TYP.	Outline shape type <sup>*5</sup>	
PQ1CG38M2FZH	<ul style="list-style-type: none"> <li>PWM chopper regulator (high oscillation frequency)</li> <li>Built-in overcurrent/overheat protection circuits</li> <li>Output ON/OFF control function</li> <li>For light load</li> </ul>	0.8 <sup>*3</sup>	40	14	VREF <sup>*4</sup> to 35 (step-down type)/ -VREF <sup>*4</sup> to -30 (inverting type)	300	0.9	TO-220	E
PQ1CG38M2RZH									D
PQ1CG21H2FZH	<ul style="list-style-type: none"> <li>PWM chopper regulator</li> <li>Built-in overcurrent/overheat protection circuits</li> <li>Output ON/OFF control function</li> </ul>	1.5 <sup>*3</sup>	40	14	VREF <sup>*4</sup> to 35 (step-down type)/ -VREF <sup>*4</sup> to -30 (inverting type)	100	1.0	TO-220	E
PQ1CG21H2RZH									D
PQ1CG41H2FZH	<ul style="list-style-type: none"> <li>PWM chopper regulator (high oscillation frequency)</li> <li>Built-in overcurrent/overheat protection circuits</li> <li>Output ON/OFF control function</li> </ul>	1.5 <sup>*3</sup>	40	14	VREF <sup>*4</sup> to 35 (step-down type)/ -VREF <sup>*4</sup> to -30 (inverting type)	300	0.9	TO-220	E
PQ1CG41H2RZH									D
PQ1CG2032FZH	<ul style="list-style-type: none"> <li>PWM chopper regulator</li> <li>Built-in overcurrent/overheat protection circuits</li> <li>Output ON/OFF control function</li> </ul>	3.5 <sup>*3</sup>	40	14	VREF <sup>*4</sup> to 35 (step-down type)/ -VREF <sup>*4</sup> to -30 (inverting type)	70	1.4	TO-220	E
PQ1CG2032RZH									D
PQ1CG3032FZH	<ul style="list-style-type: none"> <li>PWM chopper regulator (high oscillation frequency)</li> <li>Built-in overcurrent/overheat protection circuits</li> <li>Output ON/OFF control function</li> </ul>	3.5 <sup>*3</sup>	40	14	VREF <sup>*4</sup> to 35 (step-down type)/ -VREF <sup>*4</sup> to -30 (inverting type)	150	1.4	TO-220	E
PQ1CG3032RZH									D
PQ2CF1J0000H	<ul style="list-style-type: none"> <li>PWM chopper regulator</li> <li>Built-in overcurrent/overheat protection circuits</li> </ul>	2.5 <sup>*3</sup>	35	15	4.5 to 35 (step-up type)	50	0.6	TO-220	E

\*1 With infinite heat sink attached  
 \*2 Output voltage variable range  
 \*3 Peak current  
 \*4 VREF nearly equal to 1.26 V (TYP.)  
 \*5 Refer to page 55

CMOS Image Sensors/  
CCDs

LSIs for LCDs

System LSIs

Smart Card Systems

Flash Memories/  
Combination Memories

Power Devices/  
Analog ICs

Packages

Index  
(Model No.)

## Power Supply ICs for CCDs/CCD Camera Modules

Model No.	No. of output circuits	Input voltage range (V)	Output voltage (V)	System	Switching frequency (Hz)	SW Tr	Switching current (mA) [Built-in SW Tr]	Drive capacity (pF) [External SW Tr]	Package	
IR3M52Y7	5	2.7 to 5.5	15	Step-up type PWM + REG	1 M	Built-in	20 (DC)	–	41WL-CSP*2	
			–8	Inverting type PWM		External	–	1 000		
			2.5 to 3.3	REG	–	–	–	100 (DC)		–
			2.5 to 3.3	REG				100 (DC)		–
			1.8/1.2	REG				100 (DC)		–
IR3M61U*1/63U	4	4.5 to 10	15	Charge pump	200 k	–	1.2 (DC)	–	P-VQFN032-0505	
			–8	Negative charge pump			2.5 (DC)	–		
			3.3	Step-down type PWM + REG	1 M	Built-in	120 (DC)	–		
			1.8	Step-down type PWM + REG			50 (DC)	–		
IR3M49U6	4	2.7 to 5.5	15	Step-up type PWM + REG	1 M	Built-in	600 (DC)	–	P-VQFN036-0505 (*3)	
			External setting				Step-up, step-down, step-up/down type PWM	–		1 000
			External setting		Inverting type PWM	–	1 000			
			External setting		REG	–	170 (DC)	–		
IR3M55U*1/59U	3	4.5 to 16	15/12	Charge pump	200 k	–	10/20 (DC)	–	P-VQFN032-0505	
			–8/–5	Negative charge pump			2/5 (DC)	–		
			3.3	Step-down type PWM + REG	1 M	Built-in	150 (DC)	–		
IR3M48U6	3	2.7 to 3.2	15	Charge pump + REG	300 k	–	6 (DC)	–	P-VQFN032-0505 (*3)	
			–8	Negative charge pump + REG			7 (DC)	–		
			1.8	REG	–	50 (DC)	–			

\*1 For in-vehicle use

\*2 3.97 mm x 3.97 mm x 0.82 mm (TYP.)

\*3 Contact a SHARP sales office regarding a wafer-level CSP.

## Power Supply ICs for TFT-LCDs

Model No.	No. of output circuits	Input voltage range (V)	Output voltage (V)	System	Switching frequency (Hz)	SW Tr	Switching current (mA) [Built-in SW Tr]	Drive capacity (pF) [External SW Tr]	Package	
★IR3M58M/U	3	4.5 to 28	External setting	Step-up (20 V (MAX.) ) / step-down type PWM	70 k to 500 k	Built-in (Step-up type)	400	1 000	P-QFP048-0707/ P-VQFN036-0505	
				Step-down type PWM		External	–			
				Step-up, step-down type PWM		External	–			
IR3M30M/U	3	2.7 to 5.5	External setting	Step-up, step-down, step-up/down type PWM	70 k to 1 M	Built-in (Step-up type)	1 000	–	P-VQFN036-0505	
				Step-up, step-down, step-up/down, inverting type PWM		Built-in (Step-up type)	1 000	–		
				Step-up, step-down, step-up/down, inverting type PWM		External	–	1 000		
IR3M16U	3	2.6 to 3.6	External setting	15.3	100 k	–	0.1 (DC)	–	P-HQFN020-0404	
				5.1		Charge pump + REG	–	5 (DC)		–
				–10.2		Negative charge pump	–	0.1 (DC)		–

## LED drivers

### ● Built-in step up circuit

Model No.	Function	Features	No. of output circuits	Number of LEDs	Booster method	Built-in constant current circuit	Built-in SW Tr	Input voltage range (V)	Output current (mA) MAX.	Oscillation frequency fo (Hz) TYP.	Package
PQ6CU11X1APQ	White LED driver for back light (For small panel)	<ul style="list-style-type: none"> <li>High voltage CMOS output : 30 V (MAX.)</li> <li>Output ON/OFF control function</li> <li>Overcurrent/overvoltage protection circuits</li> <li>Soft start function</li> </ul>	1	3 (Series connection)	PWM	*1	○	Up to 5.5	250*2	1.2 M	SOT-23-6
PQ6CB11X1AP				4 (Series connection)		*1	○	2.7 to 5.5			USB-6
PQ6CB11X1CP				6 (Series connection)		*1	○				USB-10
★PQ7L2010BP				4 (Series connection)		*1	○	2.0 M			USB-10
IR2E46U6*/Y6	RGB LED driver for picture lights and illuminations	<ul style="list-style-type: none"> <li>I<sup>2</sup>C bus control</li> <li>Illumination mode (64 levels/ch)</li> <li>Picture light mode (32 levels/ch)</li> <li>Brightness adjustment</li> <li>Standby function/soft start function</li> <li>Overcurrent/undervoltage/overheat protection circuits</li> </ul>	3	3		○	○	2.7 to 4.5	155/ch*3 (in picture light mode)	1.2 M	33WL-CSP*5
IR2E47U6	White LED driver for back light (for small panels)	<ul style="list-style-type: none"> <li>Independent current control for two systems (4 outputs and 2 outputs)</li> <li>LED non-connected judging function</li> <li>Brightness adjustment</li> <li>Undervoltage/overheat protection circuits</li> </ul>	6	4 + 2	Charge pump	○	—	2.7 to 5.5	20/ch*3	1 M	P-HQFN024-0404
★IR2E49U	White LED driver for back light (for medium panels)	<ul style="list-style-type: none"> <li>Built-in 150 mA driver for each channel</li> <li>Step-up DC-DC output short-circuit protection function</li> <li>Current driver output open detection</li> <li>Capable of external brightness adjustment using PWM input signal</li> <li>Overcurrent/overvoltage/undervoltage/overheat protection circuits</li> </ul>	5	35	PWM	○	External	6 to 28	150/ch*3 (600 mA in total)	100 k to 1 M*4	P-VQFN036-0606
★IR2E50Y6	LED driver for back light and call alert display LED driver (auto brightness adjustment)	<ul style="list-style-type: none"> <li>Capable of direct connection of ambient light sensor</li> <li>Brightness adjustment by ambient illuminance feedback (16-step ambient illuminance/128-level illuminance) (for main LCDs)</li> <li>Non-external coil thanks to charge pump drive</li> <li>Capable of driving 4 main-LEDs, 2 sub-LEDs, and 3 call alert LEDs with a single device.</li> <li>I<sup>2</sup>C interface</li> <li>Standby function/power on reset function/soft start function</li> </ul>	9	4 + 2 + 3	Charge pump	○	—	3.0 to 4.5 (for drive)/ 2.3 to 3.2 (for control)	25/ch*3	500 k	33WL-CSP*5

\*1 LED constant current value can be set by external resistors.

\*2 Peak switch current

\*3 Constant current (MAX.)

\*4 Selectable oscillation frequency range

\*5 3.57 mm x 3.57 mm x 0.82 mm (TYP.)

### ● External power supply for LEDs

Model No.	Function	Features	Supply voltage (V)	Package
IR2D20U	24-dot LED panel driver with constant-current sink outputs	<ul style="list-style-type: none"> <li>Output current (constant current sink output) : 30 mA (MAX.) (setup by external resistor)</li> <li>Gradation function (clock cycle setting or external synchronization)</li> <li>Independent current control for three systems (for RGB LED)</li> <li>LED drive voltage : 15 V</li> <li>Rated output voltage : 20 V (MAX.)</li> <li>f<sub>CLK</sub> : 20 MHz (MAX.)/16.6 MHz (MAX.) (at cascade connection)</li> </ul>	4.5 to 5.5	P-HQFN052-0707
IR2D07N1	16-dot LED panel driver with constant current sink outputs	<ul style="list-style-type: none"> <li>Output current (constant-current sink output) : 60 mA (MAX.) (setup by external resistor)</li> <li>Rated output voltage : 7 V (MAX.)</li> <li>f<sub>CLK</sub> : 20 MHz (MAX.)/16.6 MHz (MAX.) (at cascade connection)</li> </ul>	3.0 to 5.5	P-SSOP040-0300



# Analog ICs

## Video Interface ICs for TFT-LCDs

Model No.	Input signal				Color decode	LCD panel				Serial data control	Supply voltage (V) TYP.	Power consumption (mW) TYP.	Package
	Composite video	Y/color difference	Analog RGB	OSD (Digital)		± power source	+ power source	Low voltage source	Digital input				
IR3Y18A1	○				NTSC/PAL	○	○				4.5/12 or 4.5/-7.5	130	P-QFP048-0707
IR3Y26A2/A6			○*3		-			○			5/7.5	140	P-QFP048-1010/ P-QFP048-0707
IR3Y29A1/B1	○		○		NTSC/PAL			○				190	P-QFP048-0707
IR3Y31M1	○		○		NTSC/PAL	○	○				4.5/12 or 4.5/-7.5	160	
IR3Y34M1		○	○	○	-		○				3/12	88	
IR3Y37A1		○(Common terminal)		○	-			○			3/6.5	106/88*4	
RB5P0010M2			○*3	○	-	○	○		○		3/12 or 3/4.5/-7.5	92	
RB5P0020M2		○(Common terminal)		○	-			○			3/5	70/57*4	P-QFP048-1010
RB5P0050M2		○(Common terminal)		○	-			○	○			95/80*4	
RB5P0060M2	○		○		NTSC/PAL			○	○		3/5/13	120	
RB5P006AM2	○		○		NTSC/PAL			○	○				
RB5P0070M*1	○		○	○	NTSC/PAL				○	○	3/7	330	P-QFP072-1010
RB5P0090M	○		○*3		NTSC/PAL (automatic identification)			○	○		5/13	250	P-QFP048-1010
LRS5751*2	○		○		NTSC/PAL			○			3.3/5/7.5	197	P-LQFP100-1414
LRS5752*2	○		○*3		NTSC/PAL (automatic identification)			○	○		3.3/5/13	257	

\*1 For digital signal input panels

\*2 Built-in timing generator

\*3 Two inputs

\*4 At analog input for RGB

## Power Amplifiers for Wireless LAN

Model No.	Application	Operating frequency (GHz)	Supply voltage (V) TYP.	Output power (dBm) TYP.	Supply current (mA) TYP.	Gain (dB) TYP.	Detection function	Matching circuit	Package	
IRM046U7	For 2.4 GHz wireless LAN (IEEE 802.11b/g)	2.4 to 2.5	3.3	18 (at EVM 3%)	105	30	○	–	P-HQFN024-0404	
	For 5 GHz wireless LAN (IEEE 802.11a)	4.9 to 5.9		18 (at EVM 2%)	140	25	○	–		
IRM046U8	For 2.4 GHz wireless LAN (IEEE 802.11b/g)	2.4 to 2.5		18 (at EVM 3%)	105	30	○	–		P-HQFN024-0305
	For 5 GHz wireless LAN (IEEE 802.11a)	4.9 to 5.9		18 (at EVM 2%)	140		○	–		
IRM054U7	For 2.4 GHz wireless LAN (IEEE 802.11b/g)	2.4 to 2.5		18 (at EVM 3%)	120	29	○	Built-in (IN/OUT)	P-HQFN024-0305	
	For 5 GHz wireless LAN (IEEE 802.11a)	4.9 to 5.9		18 (at EVM 2%)	150	21	○	Built-in (IN/OUT)		
★IRM062U6	For 2.4 GHz wireless LAN (IEEE 802.11b/g)	2.4 to 2.5		16	75	27	○	Built-in (IN/OUT)		P-HQFN024-0404/ P-HQFN016-0303
	For 5 GHz wireless LAN (IEEE 802.11a)	4.9 to 5.9		15	100	30	○	Built-in (IN/OUT)		
IRM047U7/U8*	For 2.4 GHz wireless LAN* (IEEE 802.11b/g)	2.4 to 2.5		18 (at EVM 3%)	105	30	○	–	P-HQFN016-0303	
IRM049U6				16 (at 802.11 b)/ 16 (at 802.11 g)	65 (at 802.11 b)/ 90 (at 802.11 g)	28/31	–	–		
★IRM060U6	For 2.4 GHz wireless LAN (IEEE 802.11b/g)	2.4 to 2.5		16 (at EVM 2%)	75	27	○	Built-in (IN/OUT)		P-HQFN016-0303
IRM052U6				18 (at EVM 3%)	120	29	○	Built-in (IN/OUT)		
IRM048U6	For 5 GHz wireless LAN (IEEE 802.11a)	4.9 to 5.9		18 (at EVM 2%)	140	30	○	–	P-HQFN024-0404	
IRM048U7						25	○	–		
IRM053U6					150	31	○	Built-in (IN/OUT)	P-HQFN016-0303	
★IRM061U6					15 (at EVM 3%)	100	30	○		Built-in (IN/OUT)

\* Can be used as a power amp for PHS and DECT (1.9 GHz band), or as a driver amp for FWA (1.9 to 2.6 GHz band).

## Power Amplifier for Cordless Phones

Model No.	Application	Operating frequency (GHz)	Supply voltage (V) TYP.	Output power (dBm) TYP.	Supply current (mA) TYP.	Gain (dB) TYP.	Operating temp. (°C)	Package
★IRM050U6	For 5.8 GHz cordless phones	5.725 to 5.85	3.3	25	220	20	–25 to 85	P-HQFN016-0303

## ■ Laser Diode Drivers

Model No.	Application	Function	Drive mode	Maximum output current (mA) MIN.	Applicable SHARP diode type	Supply voltage (V)	Package
IR3C14N1	For Mini Disc players	Built-in 100 mA driver, APC function	DC mode	100	—	2.4 to 3.5	P-SSOP008-0150
IR3C22N	For CD/DVD players	Built-in APC function, with inhibit input pin	—	150	P (Single power supply)	4.5 to 5.5	

## ■ IC for Cameras

Model No.	Function	Output/input element	Supply voltage (V)	Package
IR3S881	AF/AE/thermometry/AD (10-bit serial output for each datum), AF lens/shutter/IX magnetic head driver, zoom/film pre-driver, battery check, DC-DC converter	AF : Infrared LED, PSD*1 (active type, 1 beam), AE : SPD*2 (available for 2-part SPD)	2.2 to 6.0	P-QFP048-0707

\*1 PSD : Position Sensitive Detector

\*2 SPD : Silicon Photo Diode

## ■ Compandor

Model No.	Function/Feature	Supply voltage (V)	Operating current (mA) TYP.	Output dynamic range (mVrms) TYP.	Package
IR3N74A1	Compression and expansion of speech signal, small package	2.4 to 5.5	3.4	900	P-SSOP012-0225

## ■ ICs for Audio Equipment

Model No.	Description	Function	Supply voltage (V)	Package
IR3R55M1	RF amp IC for Mini Disc players	Built-in RF amp, ADIP detection circuit, connectable to hologram pickup	2.4 to 3.3	P-TQFP048-0707
IR3R58M1		Built-in 2x speed RF amp, ADIP detection circuit, connectable to hologram pickup		
IR3R61U	Audio amp IC	Built-in serial control input ATT and mike amp	±2.0 to ±3.25	P-HQFN020-0404
IR3R59N1		Built-in serial control input ATT and filter amp	±1.2 to ±3.25	P-SSOP024-0275
IR3M17U	Power supply IC	Two outputs (step-up, step-up/down type PWM, and step-up, step-down, step-up/down, inverting type PWM), switching frequency : 500 kHz (MAX.), external synchronization	2.2 to 6.5	P-HQFN020-0404
IR3C14N1	Laser diode driver for Mini Disc players	Built-in 100 mA driver, APC function	2.4 to 3.5	P-SSOP008-0150

# Packages

## **CSP**

CSP (Chip Size Package)	46
Wafer-level CSP	46

## **LGA**

LGA (Land Grid Array Package)	47
-------------------------------	----

## **SiP (System in Package)**

Chip Stacked CSP	48
Chip Stacked TSOP/QFP/VQFN/HQFN	48
Package Stacked	49

## **SOF**

### **Package Lineup**

Surface-mount Type	51
For CCDs	54
Lead-inserting Type	
[For regulators : PQ series]	55
Surface-mount Type	
[For regulators/LED drivers : PQ series]	56

CSP

**CSP (Chip Size Package)**

The FBGA (commonly known as CSP) has an area array terminal structure with solder balls on the bottom, to give it a near chip-size footprint. This high-density, compact and low-profile package technology will greatly help in the design of compact mobile equipment, such as cellular phones and digital cameras.

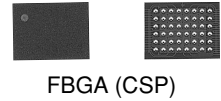

FBGA (CSP)

**Features**

- Compact and lightweight**  
 Ability to create a near-chip size and lighter-weight package in comparison with conventional plastic packages.
- High reliability**  
 Comparable high reliability with that of conventional plastic packages.
- Mountability**  
 Conventional mounting system is available for CSP. SOP and QFP can be mounted together with CSP.

Terminal pitch	0.8 mm	0.65 mm	0.5 mm	0.4 mm
Maximum terminal counts	288 (16 mm x 16 mm)	352 (16 mm x 16 mm)	424 (14 mm x 14 mm)	264 (10 mm x 10 mm)
Nominal dimensions	6 mm x 6 mm to 16 mm x 16 mm			5 mm x 5 mm to 10 mm x 10 mm

**Cross section example**

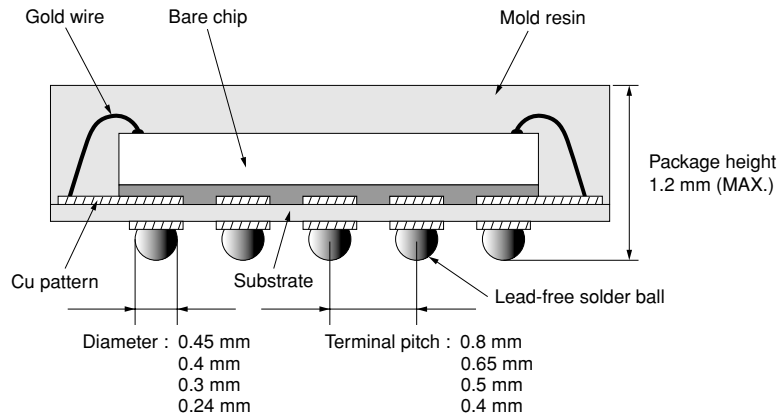

**Wafer-level CSP**

The wafer-level CSP (WL-CSP) is a kind of chip-size package which is manufactured by assembling directly onto the finished wafer.

**Features**

- Compact and thinner size**  
 It makes it possible to create an almost bare-chip-size and lighter-weight package.
- Mountability**  
 The conventional CSP mounting system can be also used in that of wafer-level CSP, which facilitates chip mounting more than bare-chip mounting does. It can be mounted together with other existing packages and passive components. (The use of underfill is recommended to improve the reliability of assembly.)

Chip size*	4 mm x 4 mm		3.5 mm x 3.5 mm		3 mm x 3 mm		2.5 mm x 2.5 mm	
Pad pitch	0.5 mm	0.4 mm	0.5 mm	0.4 mm	0.5 mm	0.4 mm	0.5 mm	0.4 mm
Maximum terminal counts	49 (7 x 7)	81 (9 x 9)	36 (6 x 6)	49 (7 x 7)	25 (5 x 5)	36 (6 x 6)	16 (4 x 4)	25 (5 x 5)

\* Rectangular chip form is also available.

**Cross section example**

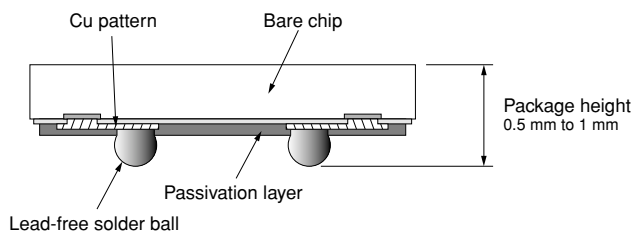

CMOS Image Sensors/ CCDs

LSIs for LCDs

System LSIs

Smart Card Systems

Flash Memories/ Combination Memories

Power Devices/ Analog ICs

Packages

Index (Model No.)

# LGA

## LGA (Land Grid Array Package)

The LGA package has basically the same structure as the CSP, enabling a thin package by removing the solder balls from the bottom of the package. The LGA package contributes to the compact and thinner design of applications, such as cellular phones and digital cameras.



<b>Features</b>	<ul style="list-style-type: none"> <li> <b>Lower package height</b>                      Achieves 0.5 mm Max. in package height.                 </li> <li> <b>High reliability</b>                      Comparable high reliability with that of conventional plastic package.                 </li> <li> <b>Excellent mountability</b>                      Conventional mounting system is available for LGA. SOP and QFP can be mounted together with LGA.                 </li> </ul>						
	<table border="1"> <tr> <td>Terminal pitch</td> <td>0.5 mm</td> </tr> <tr> <td>Maximum terminal count</td> <td>216 (10 mm x 10 mm)</td> </tr> <tr> <td>Nominal dimensions</td> <td>6 mm x 6 mm ~ 10 mm x 10 mm</td> </tr> </table>	Terminal pitch	0.5 mm	Maximum terminal count	216 (10 mm x 10 mm)	Nominal dimensions	6 mm x 6 mm ~ 10 mm x 10 mm
	Terminal pitch	0.5 mm					
Maximum terminal count	216 (10 mm x 10 mm)						
Nominal dimensions	6 mm x 6 mm ~ 10 mm x 10 mm						

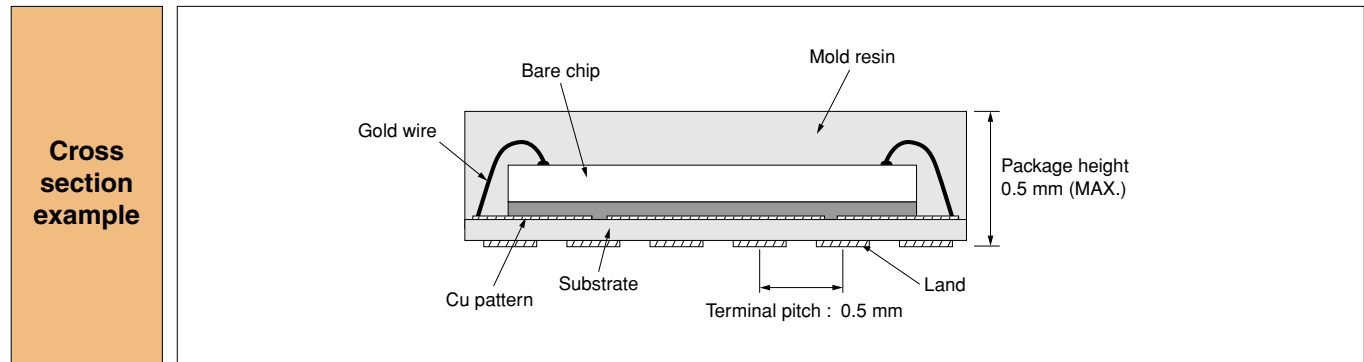

# SiP (System in Package)

System in Package is an original SHARP high-density mounting technology that achieves high-density memory capacity and multiple functions by stacking multiple bare chips or multiple packages. This technology has two major streams. One method refers to a chip-stacked package technology that can achieve up to 5-chip mounting by stacking chips in a single package. The other method refers to a package stack technology with which it is possible to stack a package of over 5 chips, by stacking multiple packages in which 1 to 2 chips are stacked. The System in Package technology contributes to higher functionality of applications, such as cellular phones and digital cameras, as well as to reduction in size and weight.

## Chip Stacked CSP

### Features

- Wide variety of lineup**  
 It is possible to provide a wide lineup of stacked CSPs, including 2-chip, 3-chip, 4-chip and 5-chip stacked CSPs, to respond to customer needs.
  - Compact and thinner size**  
 Encapsulating multiple bare chips into an existing plastic package contributes to decreasing the mounting area. In addition, SHARP's wafer thinning technology makes it possible to achieve 1.4 mm package height.
  - Multiple functions**  
 Multiple bare chips of different sizes and functions, such as logic LSIs and memories, can be incorporated in a single package, making possible multiple functions.
  - Same-size chip stacking technology**  
 SHARP's stacking technology enables stacking of multiple same-size bare chips, contributing to higher memory density.
- (4-chip stacked CSP)**  
 When using a SHARP four-chip stacked CSP, the mounting area and weight of a package can be decreased by half in comparison with using two 2-chip stacked CSPs, or a 3-chip stacked CSP and a conventional CSP.

### Cross section example

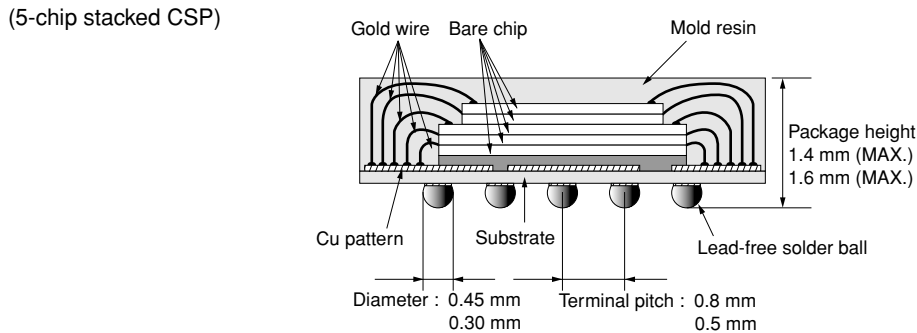

## Chip Stacked TSOP/QFP\*/ VQFN/ HQFN

### Features

- Decreased mounting area**  
 By encapsulating two identical or different types of bare chips into a single conventional plastic package, the mounting area of the package can be decreased.
- Multiple functions**  
 Thanks to the incorporation of different sizes and functions of multiple bare chips, such as logic LSIs and memories, the functionality increases.
- Higher memory density**  
 When incorporating two identical memory bare chips into a single package, memory density doubles on the same mounting area.

### Cross section example

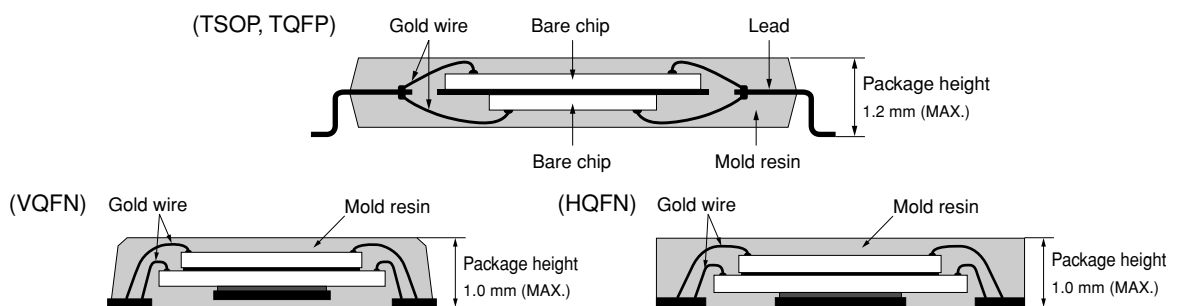

\* Including TQFP and LQFP.

CMOS Image Sensors/ CCDs  
 LSIs for LCDs  
 System LSIs  
 Smart Card Systems  
 Flash Memories/ Combination Memories  
 Power Devices/ Analog ICs  
 Packages  
 Index (Model No.)

## Package Stacked

### Features

- **Multi stacking**

The package stacking technology makes it possible to increase the memory capacity and create a combined system with memory and logic LSI. In the case of combination memories, memory capacity can be increased by stacking multiple 0.5 mm height packages in which 1 to 2 chips are stacked.

- **Decreased mounting area and height**

The package stacked technology makes it possible to decrease the mounting area by stacking multiple packages in which 1 to 2 chips are stacked, also achieving 1.5 mm height when six chips are stacked.

- **Multiple functions**

Thanks to the combination of packages in which various kinds of LSIs are mounted, such as a memory and ASIC, achieving an increase in and enhancement of functionality is easy.

### Cross section example

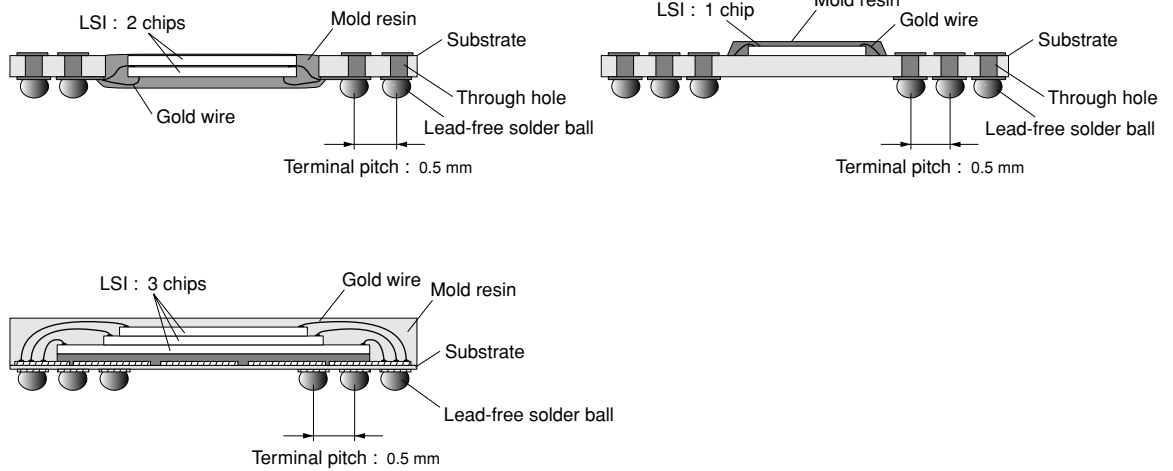

#### Examples of 3D-SiP composition

- High-density combination memory (3-package stacking)

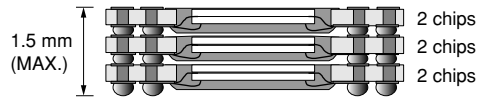
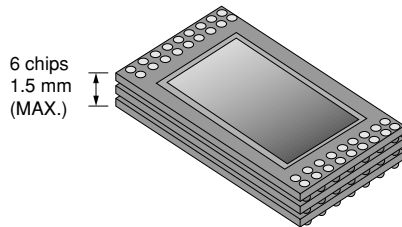

- System LSI (Logic LSI + Memory) (2-package stacking)

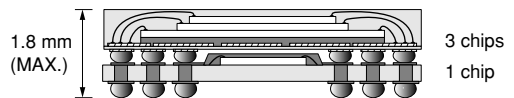
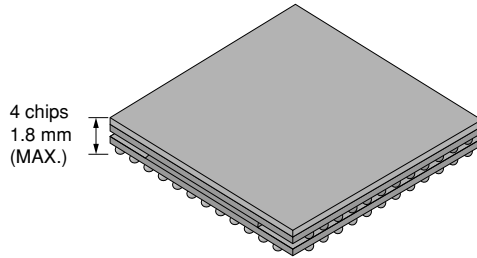

# SOF

## SOF (System On Film)

SOF is a highly flexible thin film package, created from SHARP's TCP technologies. It can be easily bent, and contributes to thin and compact design of products.

Peripheral circuit components can also be mounted.

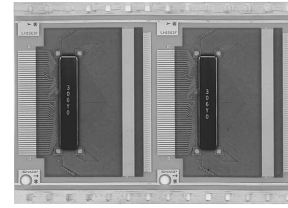

### Features

- Highly flexible and thin film package**

By using highly flexible and thin film, SOF contributes to creating thin and compact products. It can also achieve finer terminal pitches and multiple outputs easily, and pattern layout on a film under the chip makes it possible to improve the flexibility of the pattern layout.

- Multiple chip mounting**

Plural bare chip mounting and incorporation of peripheral components contribute to the higher functionality of products.

### Cross section example

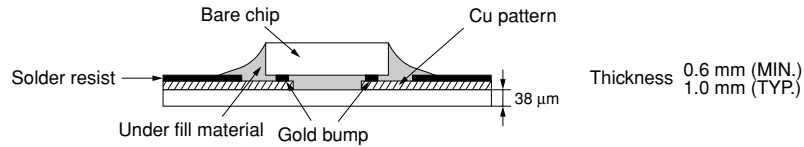

### Film specifications

Film width : $W_1$	35 mm super wide	48 mm super wide	70 mm wide
Maximum pattern layout area : $W_2$	28.6 mm	41.6 mm	59.0 mm
Maximum device pitch : L	15 sprockets		
Copper foil thickness	8 $\mu$ m		
Copper foil type	Rolled or electrolytic		
Copper foil plating	Tin (Sn)		
Minimum pattern pitch	0.029 mm		
Sprocket hole : A	1.981 mm (wide) /1.42 mm (super wide)		
Sprocket hole : B	1.981 mm (wide) /1.42 mm (super wide)		

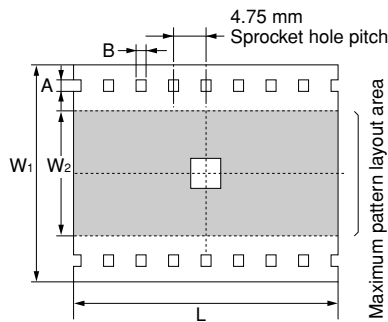

### Other components

Bare chips and peripheral circuit components can be mounted on the film.

\* In addition to the SOF described above, a conventional TCP (Tape Carrier Package) is also available.

CMOS Image Sensors/ CCDs  
LSIs for LCDs  
System LSIs  
Smart Card Systems  
Flash Memories/ Combination Memories  
Power Devices/ Analog ICs  
Packages  
Index (Model No.)



# Package Lineup

## ■ Surface-mount Type

Package type	Appearance (Package material)	Package code	No. of terminals	Terminal pitch mm	Nominal dimensions mm	Package width & length x (seated height [MAX.]) mm		
FBGA (CSP)		TFBGA048-0608	48	0.8	6 x 8	6.0 x 8.0 x (1.2)		
		TFBGA048-0808			8 x 8	8.0 x 8.0 x (1.2)		
		TFBGA060-0811	60 (48)*		8 x 11	8.0 x 11.0 x (1.2)		
		TFBGA064-0811	64			8.0 x 11.0 x (1.4) / (1.6)		
		TFBGA072-0811	72 (64)*		8 x 8	8.0 x 8.0 x (1.2)		
		LFBGA072-0811				8.0 x 11.0 x (1.4) / (1.6)		
		TFBGA081-0808	81		8 x 11	8.0 x 11.0 x (1.4) / (1.6)		
		LFBGA085-0811	85			9.0 x 12.0 x (1.4) / (1.6)		
		LFBGA087-0811	87		8 x 11	8.0 x 11.0 x (1.4) / (1.6)		
		LFBGA088-0811	88			9.0 x 12.0 x (1.4) / (1.6)		
		LFBGA088-0912			90	8 x 11	8.0 x 11.0 x (1.4) / (1.6)	
		LFBGA090-0811	96			10 x 10	10.0 x 10.0 x (1.2)	
		TFBGA096-1010			107	9 x 12	9.0 x 12.0 x (1.4) / (1.6)	
		LFBGA107-0912	112			10 x 10	10.0 x 10.0 x (1.2)	
		TFBGA112-1010			115	9 x 14	9.0 x 14.0 x (1.4) / (1.6)	
		LFBGA115-0914	116			10 x 10	10.0 x 10.0 x (1.4) / (1.6)	
		LFBGA116-1010			130	10 x 10	10.0 x 10.0 x (1.4) / (1.6)	
		LFBGA130-1013	160			10 x 13	10.0 x 13.0 x (1.4) / (1.6)	
		TFBGA160-1212			168	12 x 12	12.0 x 12.0 x (1.2)	
		LFBGA168-1212	12.0 x 12.0 x (1.4) / (1.6)					
		TFBGA180-1212	184		12 x 12	12.0 x 12.0 x (1.2)		
		TFBGA184-1212				12.0 x 12.0 x (1.2)		
		TFBGA240-1414	240		14 x 14	14.0 x 14.0 x (1.2)		
		LFBGA280-1616	280		16 x 16	16.0 x 16.0 x (1.4) / (1.6)		
		TFBGA064-0606	64		0.65	6 x 6	6.0 x 6.0 x (1.2)	
		LFBGA160-1010				10 x 10	10.0 x 10.0 x (1.4) / (1.6)	
		LFBGA192-1010				192	12 x 12	12.0 x 12.0 x (1.4) / (1.6)
		LFBGA208-1212				208		13.0 x 13.0 x (1.4) / (1.6)
		LFBGA224-1313				224	13 x 13	13.0 x 13.0 x (1.2)
		TFBGA260-1313				260		6.0 x 6.0 x (1.2)
		TFBGA068-0606	68		0.5	6 x 6	6.0 x 6.0 x (1.2)	
		TFBGA100-0707	100			7 x 7	7.0 x 7.0 x (1.2)	
		TFBGA108-0707	108				8 x 8	8.0 x 8.0 x (1.4) / (1.6)
TFBGA120-0707	120	8.0 x 8.0 x (1.2)						
LFBGA144-0808	144	8 x 11	8.0 x 11.0 x (1.4) / (1.6)					
TFBGA152-0808	152		9.0 x 9.0 x (1.2)					
LFBGA171-0811	171	0.4	9 x 9	9.0 x 9.0 x (1.2)				
TFBGA176-0909	176		10 x 10	10.0 x 10.0 x (1.2)				
TFBGA180-0909	180			14.0 x 14.0 x (1.8)				
TFBGA188-0909	188		6 x 6	6.0 x 6.0 x (0.75)				
TFBGA208-1010	208			7 x 7	7.0 x 7.0 x (1.2)			
FBGA424-1414	424		8 x 8	8.0 x 8.0 x (1.2)				
WFBGA144-0606	144	(Plastic)	0.4	8 x 8	8.0 x 8.0 x (1.2)			
TFBGA168-0707	168							
TFBGA204-0808	204							

\* Figures in brackets indicate available terminal counts.

CMOS Image Sensors/  
CCDs

LSIs for LCDs

System LSIs

Smart Card Systems

Flash Memories/  
Combination Memories

Power Devices/  
Analog ICs

Packages

Index  
(Model No.)

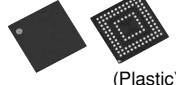

■ Surface-mount Type (cont'd)

Package type	Appearance (Package material)	Package code	No. of terminals	Terminal pitch mm	Nominal dimensions mm	Package width & length x (seated height [MAX.]) mm		
FBGA (CSP)		TFBGA <sup>XXX</sup> -0606	to 36	0.8	6 x 6	6.0 x 6.0 x (1.2)		
		TFBGA <sup>XXX</sup> -0707	to 49		7 x 7	7.0 x 7.0 x (1.2)		
		TFBGA <sup>XXX</sup> -0808	to 81		8 x 8	8.0 x 8.0 x (1.2)		
		TFBGA <sup>XXX</sup> -0909	to 100		9 x 9	9.0 x 9.0 x (1.2)		
		TFBGA <sup>XXX</sup> -1010	to 121		10 x 10	10.0 x 10.0 x (1.2)		
		TFBGA <sup>XXX</sup> -1111	to 144		11 x 11	11.0 x 11.0 x (1.2)		
		TFBGA <sup>XXX</sup> -1212	to 196		12 x 12	12.0 x 12.0 x (1.2)		
		TFBGA <sup>XXX</sup> -1313	to 216		13 x 13	13.0 x 13.0 x (1.2)		
		TFBGA <sup>XXX</sup> -1414	to 240		14 x 14	14.0 x 14.0 x (1.2)		
		TFBGA <sup>XXX</sup> -1515	to 280		15 x 15	15.0 x 15.0 x (1.2)		
		TFBGA <sup>XXX</sup> -1616	to 280	16 x 16	16.0 x 16.0 x (1.2)			
		TFBGA <sup>XXX</sup> -0606	to 49	0.65	6 x 6	6.0 x 6.0 x (1.2)		
		TFBGA <sup>XXX</sup> -0707	to 81		7 x 7	7.0 x 7.0 x (1.2)		
		TFBGA <sup>XXX</sup> -0808	to 121		8 x 8	8.0 x 8.0 x (1.2)		
		TFBGA <sup>XXX</sup> -0909	to 144		9 x 9	9.0 x 9.0 x (1.2)		
		TFBGA <sup>XXX</sup> -1010	to 196		10 x 10	10.0 x 10.0 x (1.2)		
		TFBGA <sup>XXX</sup> -1111	to 224		11 x 11	11.0 x 11.0 x (1.2)		
		TFBGA <sup>XXX</sup> -1212	to 256		12 x 12	12.0 x 12.0 x (1.2)		
		TFBGA <sup>XXX</sup> -1313	to 272		13 x 13	13.0 x 13.0 x (1.2)		
		TFBGA <sup>XXX</sup> -1414	to 304		14 x 14	14.0 x 14.0 x (1.2)		
		TFBGA <sup>XXX</sup> -1515	to 320		15 x 15	15.0 x 15.0 x (1.2)		
		TFBGA <sup>XXX</sup> -1616	to 352	16 x 16	16.0 x 16.0 x (1.2)			
		FLGA (LGA)		TFBGA <sup>XXX</sup> -0606	to 100	0.5	6 x 6	6.0 x 6.0 x (1.2)
				TFBGA <sup>XXX</sup> -0707	to 132		7 x 7	7.0 x 7.0 x (1.2)
				TFBGA <sup>XXX</sup> -0808	to 164		8 x 8	8.0 x 8.0 x (1.2)
				TFBGA <sup>XXX</sup> -0909	to 192		9 x 9	9.0 x 9.0 x (1.2)
				TFBGA <sup>XXX</sup> -1010	to 216		10 x 10	10.0 x 10.0 x (1.2)
				TFBGA <sup>XXX</sup> -1111	to 244		11 x 11	11.0 x 11.0 x (1.2)
				TFBGA <sup>XXX</sup> -1212	to 268		12 x 12	12.0 x 12.0 x (1.2)
				TFBGA <sup>XXX</sup> -1313	to 296		13 x 13	13.0 x 13.0 x (1.2)
				TFBGA <sup>XXX</sup> -1414	to 320		14 x 14	14.0 x 14.0 x (1.2)
				TFBGA <sup>XXX</sup> -1515	to 348		15 x 15	15.0 x 15.0 x (1.2)
				TFBGA <sup>XXX</sup> -1616	to 372	16 x 16	16.0 x 16.0 x (1.2)	
TFBGA <sup>XXX</sup> -0505	to 100			0.4	5 x 5	5.0 x 5.0 x (1.2)		
TFBGA <sup>XXX</sup> -0606	to 144				6 x 6	6.0 x 6.0 x (1.2)		
TFBGA <sup>XXX</sup> -0707	to 168				7 x 7	7.0 x 7.0 x (1.2)		
TFBGA <sup>XXX</sup> -0808	to 204				8 x 8	8.0 x 8.0 x (1.2)		
TFBGA <sup>XXX</sup> -0909	to 228				9 x 9	9.0 x 9.0 x (1.2)		
(Plastic)	TFBGA <sup>XXX</sup> -1010			to 264	10 x 10	10.0 x 10.0 x (1.2)		
FLGA (LGA)		XFLGA100-0707	100	0.5	7 x 7	7.0 x 7.0 x (0.5)		

XXX : Terminal counts

CMOS Image Sensors/ CCDs  
LSIs for LCDs  
System LSIs  
Smart Card Systems  
Flash Memories/ Combination Memories  
Power Devices/ Analog ICs  
Packages  
Index (Model No.)

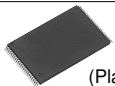
■ Surface-mount Type (cont'd)



Package type	Appearance (Package material)	Package code	No. of terminals	Terminal pitch mm (mil)	Nominal dimensions mm (mil)	Package width & length x (seated height [MAX.]) mm	Lead frame material		
							Alloy42	Copper alloy	
SOP	 (Plastic)	P-SOP044-0600	44	1.27 (50)	15.2 (600)	13.2 x 28.2 x (3.1)	○	○	
SSOP		P-SSOP008-0150	8	0.65	4.5 (150)	3.0 x 3.0 x (1.1)	—	○	
		P-SSOP012-0225	12	0.75	5.7 (225)	4.4 x 5.0 x (1.8)	○	—	
		P-SSOP024-0275	24	0.65	7.0 (275)	6.0 x 7.8 x (1.27)	—	○	
		P-SSOP040-0300	40		7.6 (300)	6.3 x 13.5 x (1.8)	—	○	
		P-SSOP070-0500	70	0.8	12.7 (500)	12.7 x 28.6 x (3.05)	—	○	
MFP		P-MFP018	18	0.8	—	6.0 x 7.5 x (1.8)	○	—	
		P-MFP020	20	0.75	—	6.0 x 7.5 x (1.8)	○	—	
TSOP		 (Plastic)	P-TSOP040-1020	40	0.5	10 x 20	10.0 x 18.4 x (1.2)	○	○
			P-TSOP048-1220	48		12 x 20	12.0 x 18.4 x (1.2)	○	○
	P-TSOP056-1420		56	14 x 20		14.0 x 18.4 x (1.2)	○	○	
QFP	 (Plastic)	P-QFP048-0707	48	0.5	7 x 7	7.0 x 7.0 x (1.65)	○	—	
		P-QFP048-1010		0.75	10 x 10	10.0 x 10.0 x (1.82)	○	—	
		P-QFP064-1010	64	0.5	10 x 10	10.0 x 10.0 x (1.8)	○	—	
		P-QFP072-1010	72				○	—	
		P-QFP128-1420	128	0.4	14 x 20	14.0 x 20.0 x (2.3)	○	—	
		P-QFP156-1420	156				○	—	
LQFP		P-LQFP080-1212	80	0.5	12 x 12	12.0 x 12.0 x (1.7)	○	—	
		P-LQFP100-1414	100		14 x 14	14.0 x 14.0 x (1.7)	○	—	
		P-LQFP144-2020	144		20 x 20	20.0 x 20.0 x (1.7)	—	○	
		P-LQFP176-2424	176	0.4	24 x 24	24.0 x 24.0 x (1.7)	—	○	
		★P-LQFP256-2828	256		28 x 28	28.0 x 28.0 x (1.7)	—	○	
		TQFP	P-TQFP048-0707	48	0.5	7 x 7	7.0 x 7.0 x (1.2)	○	—
P-TQFP100-1414	100		0.4	14 x 14	14.0 x 14.0 x (1.2)	○	—		
P-TQFP128-1414	128					○	—		
VQFN	 (Plastic)	P-VQFN020-0404	20	0.5	4 x 4	4.2 x 4.2 x (1.0)	—	○	
		P-VQFN028-0505	28		5 x 5	5.2 x 5.2 x (1.0)	—	○	
		P-VQFN032-0505	32		6 x 6	6.2 x 6.2 x (1.0)	—	○	
		P-VQFN036-0606	36		7 x 7	7.2 x 7.2 x (1.0)	—	○	
		P-VQFN048-0707	48	0.4	5 x 5	5.2 x 5.2 x (1.0)	—	○	
		P-VQFN036-0505	36		7 x 7	7.2 x 7.2 x (1.0)	—	○	
		P-VQFN052-0707	52		8 x 8	8.2 x 8.2 x (1.0)	—	○	
		P-VQFN064-0808	64		—	○			
HQFN*		P-HQFN016-0303	16	0.5	3 x 3	3.0 x 3.0 x (0.85)	—	○	
		P-HQFN016-0404		0.65	4 x 4	4.0 x 4.0 x (1.0)	—	○	
		P-HQFN020-0404	20	0.5	3 x 5	3.0 x 5.0 x (0.85)	—	○	
		★P-HQFN024-0305			4 x 4	4.0 x 4.0 x (0.85)	—	○	
		P-HQFN024-0404	24	0.5	4 x 4	4.2 x 4.2 x (1.0)	—	○	
		P-HQFN028-0505			5 x 5	5.0 x 5.0 x (1.0)	—	○	
		P-HQFN052-0707	52	0.4	7 x 7	7.2 x 7.2 x (1.0)	—	○	

\* HQFN is a higher heat dissipation package of VQFN.

100 mil = 2.54 mm

CMOS Image Sensors/  
CCDs  
LSIs for LCDs  
System LSIs  
Smart Card Systems  
Flash Memories/  
Combination Memories  
Power Devices/  
Analog ICs  
Packages  
Index  
(Model No.)

■ For CCDs

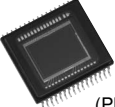
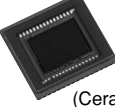
Package type	Appearance (Package material)	Package code	No. of terminals	Terminal pitch mm	Nominal dimensions mm (mil)	Package width & length x (seated height) mm
DIP	 (Plastic)	P-DIP014-0400A	14	1.27	10.16 (400)	10.0 x 10.0
		P-DIP016-0500C	16	1.78	12.7 (500)	12.4 x 14.0
		P-DIP020-0400	20	1.00	10.16 (400)	10.0 x 10.0
	 (Ceramic)	N-DIP016-0450	16	1.27	11.43 (450)	11.4 x 12.2
		N-DIP016-0500C		1.78	12.7 (500)	12.4 x 14.0
SOP	 (Plastic)	P-SOP028-0400	28	0.69	10.16 (400)	10.0 x 10.0 x (3.5)
		P-SOP032-0525	32	0.78	13.3 (525)	12.0 x 13.8 x (3.9)
LCC	 (Ceramic)	N-LCC028-S450B	28	0.80	11.5	11.5 x 11.5 x (1.62)
		N-LCC032-R543	32	0.80	13.8	12.9 x 13.8 x (1.35)

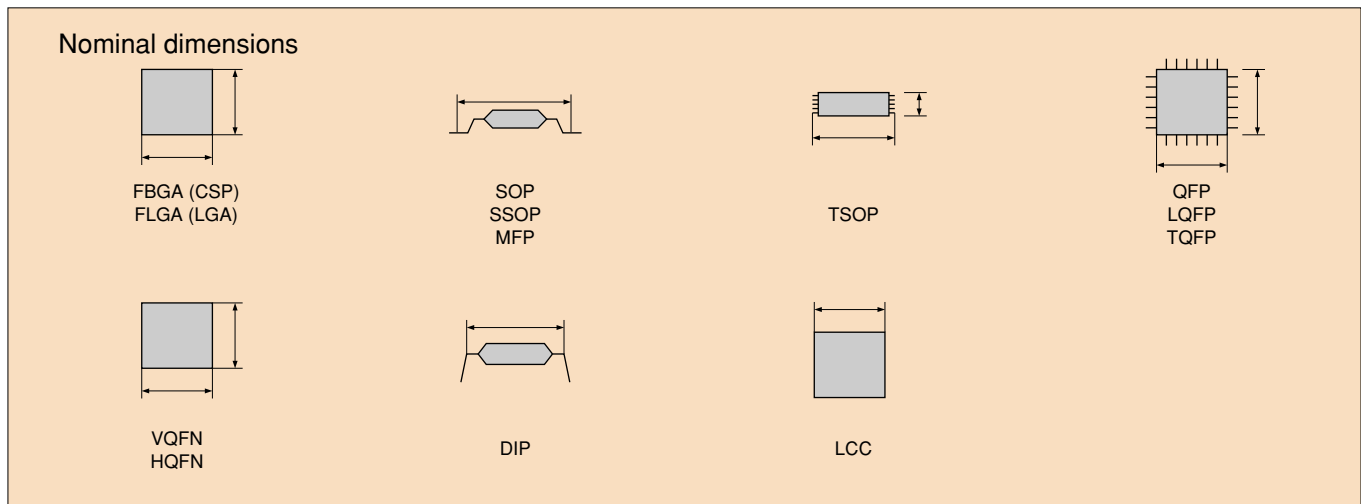

100 mil = 2.54 mm



- FBGA : fine-pitch ball grid array package
- FLGA : fine-pitch land grid array package
- SOP : small outline package
- SSOP : shrink small outline package
- MFP : mini flat package
- TSOP : thin small outline package
- QFP : quad flat package
- LQFP : low profile quad flat package
- TQFP : thin quad flat package
- VQFN : very thin quad flat non-leaded package
- HQFN : heat sink quad flat non-leaded package
- DIP : dual inline package
- LCC : leadless chip carrier

CMOS Image Sensors/ CCDs  
 LSIs for LCDs  
 System LSIs  
 Smart Card Systems  
 Flash Memories/ Combination Memories  
 Power Devices/ Analog ICs  
 Packages  
 Index (Model No.)

■ Lead-inserting Type Packages [For regulators : PQ series]

Package type	Appearance (Package material)	No. of terminals	Terminal pitch mm	Outline dimensions (Width x Thickness x Height) mm	Lead frame material
TO-3P	 (Plastic)	5	2.54	17 (MAX.) x 4.5 x 39 <sup>*2</sup>	Cu
TO-220 (Heat sink exposure) [Lead forming type]	 (Plastic)	5	(1.7) <sup>*1</sup>	10.2 (MAX.) x 3.5 x 25.2 <sup>*2</sup>	Cu
TO-220 <b>A</b>	 (Plastic)	4	2.54	10.2 (MAX.) x 4.5 x 29.1 <sup>*2</sup>	Cu
TO-220 (Full mold) <b>B</b>	 (Plastic)	4	2.54	10.2 (MAX.) x 4.5 x 29.1 <sup>*2</sup>	Cu
TO-220 (Full mold) [Lead forming type] <b>C</b>	 (Plastic)	5	(1.7) <sup>*1</sup>	10.2 (MAX.) x 4.5 x 24.6 <sup>*2</sup>	Cu
TO-220 [Lead forming type] <b>D</b>	 (Plastic)	5	(1.7) <sup>*1</sup>	10.2 (MAX.) x 4.5 x 24.6 <sup>*2</sup>	Cu
TO-220 [Lead forming type] <b>E</b>	 (Plastic)	5	(1.7) <sup>*1</sup>	10.2 (MAX.) x 4.5 x 24.6 <sup>*2</sup>	Cu
TO-92	 (Plastic)	3	2.5	5.2 (MAX.) x 4.2 (MAX.) x 18.2 (MAX.) <sup>*2</sup>	Cu

\*1 The figure in parentheses indicates reference value.

\*2 Including lead length

■ Surface-mount Type Packages [For regulators/LED drivers : PQ series]

Package type	Appearance (Package material)	No. of terminals	Terminal pitch mm	Outline dimensions (Width x Height x Thickness) mm	Lead frame material
TO-263	 (Plastic)	5 (Heat sink not included)	(1.7)* <sup>1</sup>	10.6 (MAX.) x 13.7 (MAX.)* <sup>2</sup> x 3.5	Cu
SC-63	<b>F</b>  (Plastic)	5 (Heat sink not included)	(1.27)* <sup>1</sup>	6.6 (MAX.) x 9.7 (MAX.)* <sup>2</sup> x 2.3	Cu
SC-63	<b>G</b>  (Plastic)	5 (Heat sink included)	(1.27)* <sup>1</sup>	6.6(MAX.) x 9.7 (MAX.)* <sup>2</sup> x 2.1	Cu
SOP-8	 (Plastic)	8	1.27	5 x 6.2* <sup>2</sup> x 1.55* <sup>2</sup>	Cu
SOT-89	 (Plastic)	6	1.5	4.5 x 4.3* <sup>2</sup> x 1.5	Cu
SOT-23-6	 (Plastic)	6	0.95	2.9 x 2.8* <sup>2</sup> x 1.3	Cu
SOT-23-6W	 (Plastic)	6	0.95	2.9 x 2.8* <sup>2</sup> x 1.3	Cu
SOT-23-L	 (Plastic)	6	(0.95)* <sup>1</sup>	(3.4)* <sup>1</sup> x 3.3* <sup>2</sup> x 1.4 (MAX.)	Cu
SOT-23-5	 (Plastic)	5	(0.95)* <sup>1</sup>	(2.9)* <sup>1</sup> x 2.8* <sup>2</sup> x 1.3 (MAX.)	Cu
USB-6		6	0.5	2.0 x 1.8 x 0.8	Cu (Terminal material)/ Au plating (Terminal finish)
USB-10		10	0.5	2.8 x 2.0 x 0.8	—
LNC-8		8	0.65	2.85 x 2.45 x 0.75	Cu (Terminal material)/ Au plating (Terminal finish)

\*1 The figure in parentheses indicates reference value.

\*2 Including lead length

CMOS Image Sensors/ CCDs  
LSIs for LCDs  
System LSIs  
Smart Card Systems  
Flash Memories/ Combination Memories  
Power Devices/ Analog ICs  
Packages  
Index (Model No.)



# Index (Model No.)

CMOS Image Sensors/  
CCDs

A	Page
ARM720T	20, 22
ARM7TDMI	19, 20, 22
ARM922T	20, 22
ARM926EJ-S	22
ARM946E-S	22

LSIs for LCDs

IR2	Page
IR2D07N1	41
IR2D20U	41
IR2E46U6	41
IR2E46Y6	41
IR2E47U6	41
IR2E49U	41
IR2E50Y6	41

IR3C	Page
IR3C14N1	44
IR3C22N	44

System LSIs

IR3E	Page
IR3E11A1	16
IR3E11M1	16
IR3E11P1	16
IR3E12M1	16
IR3E13N	16
IR3E13U	16
IR3E2015	16
IR3E2045	16
IR3EXX	16

Smart Card Systems

IR3M	Page
IR3M16U	16, 40
IR3M17U	38, 44
IR3M18N	38
IR3M19N	38
IR3M30M	16, 39, 40
IR3M30U	16, 39, 40
IR3M48U6	4, 40
IR3M49U6	40
IR3M52Y7	4, 40
IR3M55U	7, 40
IR3M56N	38
IR3M57N	39
IR3M58M	16, 39, 40
IR3M58U	16, 39, 40
IR3M59U	7, 9, 10, 40
IR3M61U	7, 40
IR3M63U	7, 8, 40

Flash Memories/  
Combination Memories

IR3N	Page
IR3N74A1	44

IR3R	Page
IR3R55M1	44
IR3R58M1	44
IR3R59N1	44
IR3R61U	44

Power Devices/  
Analog ICs

IR3S	Page
IR3S881	44

Packages

IR3Y	Page
IR3Y18A1	16, 42
IR3Y26A2	16, 42
IR3Y26A6	16, 42
IR3Y29A1	16, 42
IR3Y29B1	16, 42
IR3Y30M1	6, 10
IR3Y31M2	16, 42
IR3Y34M1	16, 42
IR3Y37A1	16, 42

Index  
(Model No.)

IR3Y48A3	6, 9, 10
IR3Y48A5	6
IR3Y50U6	6
IR3Y60U6	6, 9, 10

IRM	Page
IRM046U7	43
IRM046U8	43
IRM047U7	43
IRM047U8	43
IRM048U6	43
IRM048U7	43
IRM049U6	43
IRM050U6	43
IRM052U6	43
IRM053U6	43
IRM054U7	43
IRM060U6	43
IRM061U6	43
IRM062U6	43

LH0	Page
LH0E776	19

LH15	Page
LH1530	13
LH1537	13
LH1538	13
LH1542	13
LH1548	13
LH1549	13
LH1560	13
LH1562	13
LH1565	13
LH1580	13
LH1583	13
LH15H1	15
LH15JA	15
LH15KA	15
LH15LA	15

LH16	Page
LH1687	13
LH168R	12
LH168V	12
LH168Y	13
LH1691	12, 13
LH1694	12
LH169C	14
LH169G	12
LH169H	13
LH16A1	12
LH16AD	12
LH16AE	12
LH16AF	12
LH16AM	12
LH16AP	14
LH16AR	13
LH16AV	13
LH16AW	12
LH16B0	12
LH16B1	12
LH16B2	12
LH16B3	12
LH16B5	12
LH16B6	12

LH2	Page
LH28F008BJ-BTL	27, 29
LH28F008BJ-TTL	27, 29
LH28F128BFH-PBTL	27, 29
LH28F128BFH-PTTL	27, 29
LH28F128BF-PBTL	27, 29

LH28F128BF-PTTL	27, 29
LH28F160BJH-PBTL	27, 29
LH28F160BJH-PTTL	27, 29
LH28F256BF-PTSL	28, 30
LH28F320BFH-PBTL	27, 29
LH28F320BFH-PTTL	27, 29
LH28F320BF-PBTL	27, 29
LH28F320BF-PTTL	27, 29
LH28F512BF-PTSL	28, 30
LH28F640BFH-PBTL	27, 29
LH28F640BFH-PTTL	27, 29
LH28F640BF-PBTL	27, 29
LH28F640BF-PTTL	27, 29
LH28F800BJH-43	27, 29
LH28F800BJH-PBTL	27, 29
LH28F800BJH-PTTL	27, 29
LH28F800BJ-PBTL	27, 29
LH28F800BJ-PTTL	27, 29

LH7	Page
-----	------

LH75400	20
LH75401	20
LH75410	20
LH75411	20
LH79520	20
LH79524	20
LH79525	20
LH79532A	19
LH79532Y	19
LH79533A	19
LH7A400	20
LH7A404	20

LHF	Page
-----	------

LHF00L04	28, 30
LHF00L08	28, 30
LHF00L09	28, 30
LHF00L10	28, 30
LHF00L11	28, 30
LHF00L14	28, 30
LHF00L15	28, 30
LHF00L21	28, 30
LHF00L24	28, 30
LHF00L25	28, 30
LHF00L28	28, 30
LHF00L29	28, 30

LR3	Page
-----	------

LR35501	18
LR35501Y	18
LR366851	6, 10
LR36687U	6
LR36687Y	6
LR36689U	6
LR3697A	13
LR385851	6, 10
LR386032	7, 10
LR386071	7, 10
LR386431	6, 9
LR386433	6, 9
LR38653	6, 8
LR38667	6, 8
LR38669A	7, 8, 18
LR38671	4
LR38674	6, 8
LR38675	6, 8
LR38677	6, 8
LR38678	6, 8
LR38682	7, 18
LR38683	7, 18
LR38822A	14
LR38825	14
LR38826	14

LR38844A	15
LR38869A	14
LR388733	18
LR38875	18
LR38886	18
LR38888	18

LR5	Page
-----	------

LR550R03	25
----------	----

LRS	Page
-----	------

LRS1871A	31
LRS1872A	31
LRS18831	31
LRS18841	31
LRS1887B	31
LRS1890A	31
LRS1897	31
LRS18A6	31
LRS18AC	31
LRS18AZ	31
LRS18B0	31
LRS18BK	31
LRS18BL	31
LRS18BN	31
LRS18BP	31
LRS18BR	31
LRS18BT	31
LRS18C8A	31
LRS18CC	31
LRS5751	16, 42
LRS5752	16, 42
LRS5753	6, 9

LZ0	Page
-----	------

LZ0P371K	4
LZ0P371L	4
LZ0P374H	4
LZ0P374P	4
LZ0P374R	4
LZ0P3758	4
LZ0P375D	4
LZ0P392L	3
LZ0P392N	3
LZ0P3936	3
LZ0P393D	3
LZ0P393E	3
LZ0P393M	3
LZ0P394K	3
LZ0P394U	3
LZ0P3954	3
LZ0P3955	3
LZ0P396D	3

LZ2	Page
-----	------

LZ2316A3	5, 10
LZ2326A3	5, 10

PQ0	Page
-----	------

PQ015YZ01ZPH	36
PQ015YZ5MZPH	36
PQ033ES1MXPQ	34
PQ033ES3MXPQ	34
PQ035ZN01ZPH	36
PQ035ZN1HZPH	36
PQ050ES1MXPQ	34
PQ050ES3MXPQ	34
PQ05VY053ZPH	37
PQ05VY3H3ZPH	37
PQ070VK01FZH	33
PQ070VK02FZH	33
PQ070XF01SZH	33
PQ070XF02SZH	33

# Index (Model No.)

PQ070XH01ZPH	37
PQ070XH02ZPH	37
PQ070XN01ZPH	36
PQ070XNA1ZPH	36
PQ070XNAHZPH	36
PQ070XZ01ZPH	36
PQ070XZ02ZPH	36
PQ070XZ1HZPH	36
PQ070XZ5MZPH series	36
PQ07VR5MAPH series	36

## PQ1 Page

PQ150RWA2SZH	33
PQ150VB01FZH	33
PQ150VB02FZH	33
PQ15RW08J00H	33
PQ15RW11J00H	33
PQ15RW21J00H	33
PQ1CG2032FZH	39
PQ1CG2032RZH	39
PQ1CG21H2FZH	39
PQ1CG21H2RZH	39
PQ1CG3032FZH	39
PQ1CG3032RZH	39
PQ1CG38M2FZH	39
PQ1CG38M2RZH	39
PQ1CG41H2FZH	39
PQ1CG41H2RZH	39
PQ1CX12H2ZPQ	38
PQ1CX22H2ZPQ	38
PQ1CY1032ZPH	38
PQ1CYxx3HZPH series	38
PQ1CYxx3LZPH series	38
PQ1CZ21H2ZPH	38
PQ1CZ38M2ZPH series	38
PQ1CZ41H2ZPH	38
PQ1DX095MZPQ	37
PQ1DX125MZPQ	37
PQ1KAxx3MZPH series	35
PQ1Kxx3M2ZPH series	35
PQ1LAX95MSPQ	35
PQ1LAXx3MSPQ	35
PQ1Lxx3M2SPQ	35
PQ1MX55M2SPQ	35
PQ1Mxx5M2SPQ	35
PQ1Nxx3MxSPQ	35
PQ1RxxJ0000H series	35
PQ1Uxx1M2ZPH series	35
PQ1Xxx1M2ZPH series	35

## PQ2 Page

PQ200WNA1ZPH	36
PQ20RX05J00H	33
PQ20RX11J00H	33
PQ20VZ11J00H	36
PQ20VZ51J00H	36
PQ20WZ11J00H	36
PQ20WZ51J00H	36
PQ2CF1J0000H	39
PQ2Lxxx2MSPQ	35

## PQ3 Page

PQ30RV11J00H	33
PQ30RV21J00H	33
PQ30RV31J00H	33
PQ3DZ13J000H	36
PQ3DZ53J000H	36
PQ3RD083J00H	33
PQ3RD13J000H	33
PQ3RD23J000H	33
PQ3RF23J000H	33
PQ3RF33J000H	33

## PQ5 Page

PQ5CAD1xxxP series	39
PQ5EV3J0000H	34
PQ5EV5J0000H	34
PQ5EV7J0000H	34

## PQ6 Page

PQ6CB11X1AP	38, 41
PQ6CB11X1CP	38, 41
PQ6CU11X1APQ	38, 41
PQ6CU12X2APQ	38
PQ6RD083J00H	33

## PQ7 Page

PQ7DV10J000H	34
PQ7DV5J0000H	34
PQ7L2010BP	38, 41
PQ7RV4J0000H	33

## PQxx Page

PQxxDZ11J00H series	36
PQxxDZ51J00H series	36
PQxxRA11J00H series	33
PQxxRD08J00H series	33
PQxxRD11J00H series	33
PQxxRD21J00H series	33
PQxxRF11J00H series	33
PQxxRF21J00H series	33
PQxxRH11J00H series	33

## PQxxx Page

PQxxxDNA1ZPH series	36
PQxxxDZ01ZPH series	36
PQxxxEF01SZH series	33
PQxxxEF02SZH series	33
PQxxxEH01ZPH	37
PQxxxEH02ZPH	37
PQxxxEHS2ZPH	37
PQxxxEN01ZPH series	36
PQxxxENA1ZPH series	36
PQxxxENAHZPH series	36
PQxxxEZ01ZPH series	36
PQxxxEZ02ZPH series	36
PQxxxEZ1HZPH series	36
PQxxxEZ5MZPH series	36
PQxxxFZ01ZPH series	36
PQxxxFZ5MZPH series	36
PQxxxGN01ZPH series	36
PQxxxGN1HZPH series	36
PQxxxRDA1SZH series	33
PQxxxRDA2SZH series	33
PQxxxY053ZPH	37
PQxxxY3H3ZPH	37

## RB Page

RB5P0010M2	16, 42
RB5P0020M2	16, 42
RB5P0050M2	16, 42
RB5P0060M2	16, 42
RB5P006AM2	16, 42
RB5P0070M	16, 42
RB5P0090M	16, 42

## RJ21 Page

RJ21V3BC0ET	5, 8
RJ21V3CC0ET	5, 8
RJ21W3BA0ET	5, 8
RJ21W3CA0ET	5, 8

## RJ23 Page

RJ2311AA0PB	5, 8, 9, 10
RJ2321AA0PB	5, 8, 9, 10
RJ2351AA0BB	5, 8, 9, 10
RJ2351BA0AB	5, 8, 9, 10
RJ2361AA0BB	5, 8, 9, 10
RJ2361BA0AB	5, 8, 9, 10
RJ23S3BC0ET	5, 8
RJ23S3CC0ET	5, 8
RJ23T3BA0ET	5, 8
RJ23T3BB0ET	5, 8
RJ23T3CA0ET	5, 8
RJ23T3CB0ET	5, 8
RJ23U3BA0ET	5, 8
RJ23U3CA0ET	5, 8

## RJ24 Page

RJ2411AA0PB	5, 8, 9
RJ2411AB0PB	5, 8, 9, 10
RJ2411BA0PB	5, 8, 9
RJ2411BB0PB	5, 8, 9, 10
RJ2421AB0PB	5, 8, 9, 10
RJ2421BB0PB	5, 8, 9, 10
RJ2451AA0PB	5, 8, 9, 10
RJ2461AA0PB	5, 8, 9, 10

## RW Page

RW4040	25
--------	----

# SHARP

## SHARP CORPORATION

SALES & MARKETING GROUP  
-ELECTRONIC COMPONENTS & DEVICES  
22-22, NAGAIKE-CHO, ABENO-KU, OSAKA 545-8522, JAPAN  
PHONE : (81) 6-6621-1221  
FAX : (81) 6117-725300, (81) 6117-725301, (81) 6117-725302  
<http://sharp-world.com/products/device/>

## COUNTRIES and AREAS

### U.S.A.

#### SHARP MICROELECTRONICS OF THE AMERICAS

**North American Head Office**  
5700 NW Pacific Rim Boulevard  
Camas, WA 98607 USA  
PHONE : (1) 360-834-2500  
FAX : (1) 360-834-8903  
<http://www.sharpsma.com>

**Western area**  
1980 Zanker Road, San Jose, CA 95112  
PHONE : (1) 408-436-4900  
FAX : (1) 408-436-0924

5901 Bolsa Ave.  
Huntington Beach, CA 92647-2053  
PHONE : (1) 714-903-4600  
FAX : (1) 714-903-0295

6390 Greenwich Drive, Suite 175  
San Diego, CA 92122  
PHONE : (1) 858-597-0982  
FAX : (1) 858-597-8701

**Eastern area**  
85 W. Algonquin Road, Suite 280  
Arlington Heights, IL 60005  
PHONE : (1) 847-258-2750  
FAX : (1) 847-439-2479

6303 Commerce Drive, Suite 175  
Irving, TX 75063  
PHONE : (1) 972-582-1710  
FAX : (1) 972-580-7537

8911 Capitol of Texas Hwy, Suite 3130  
Austin, TX 78759  
PHONE : (1) 512-349-7262  
FAX : (1) 512-349-7002

3001 West Big Beaver Road, Suite 722  
Troy, MI 48064  
PHONE : (1) 248-458-1527  
FAX : (1) 248-458-6255

200 Wheeler Rd., Burlington, MA 01803  
PHONE : (1) 781-270-7979  
FAX : (1) 781-229-9117

8000 Regency Parkway, Suite 280  
Cary, NC 27511  
PHONE : (1) 919-460-0695  
FAX : (1) 919-460-0795

### EUROPE

#### SHARP MICROELECTRONICS EUROPE a division of Sharp Electronics (Europe) GmbH

**Head Office**  
Sonninstrasse 3, 20097, Hamburg,  
Germany  
PHONE : (49) 1805-073507  
FAX : (49) 40-2376-2232  
<http://www.sharpsme.com/>

**Germany :**  
**SME Munich Office**  
Landsberger Strasse 398,  
81241 Munich, Germany  
PHONE : (49) 89-54 6842 0  
FAX : (49) 89-54 6842 50

**France :**  
**SME Paris Office**  
1 Rue Raoul Follereau  
Bussy Saint Georges  
77608 Marne la Vallée Cedex 3  
PHONE : (33) 1 6476 22 22  
FAX : (33) 1 6476 22 23

**Italy :**  
**SME Milano Office**  
Centro Direzionale Colleoni  
Palazzo Taurus Ingresso 2  
20041 Agrate Brianza, Milano, Italy  
PHONE : (390) 39-68 99 946  
FAX : (390) 39-68 99 948

**U.K. :**  
**SME London Office**  
Centennial Court, Eastthampstead Road,  
Bracknell, Berkshire RG12 1YQ,  
United Kingdom  
PHONE : (44) 1344-86 99 22  
FAX : (44) 1344-36 09 03

**Ireland :**  
**SME Dublin Office**  
7 Chetnut Road Donnyrne  
Co meath Ireland  
PHONE : (353) 1-842 87 05  
FAX : (353) 1-842 84 85

### ASIA

#### SHARP ELECTRONICS (SHANGHAI) CO., LTD.

**Microelectronics Sales & Marketing Division**  
16F, King Tower, 28 Xin Jin Qiao Road,  
Pudong DIST, Shanghai 201206 P.R. China  
PHONE : (86) 21-5854-7710/21-5834-6056  
FAX : (86) 21-5854-4340/21-5834-6057  
<http://sharp-world.com/products/device-china/index.html>

**Registered Address**  
No. 273, De Bao Road, Xin Development  
BLDG 58 Wai Gao Qiao Free Trade Zone,  
Shanghai 200131, P.R. China

**Beijing office**  
Room 1062, Beijing Jing An Center No. 8  
East Bei San Huan Road, Chao Yang  
DIST., Beijing 100028 P.R. China  
PHONE : (86) 10-6466-7543/10-6466-6561  
FAX : (86) 10-6468-8920

#### SHARP-ROXY (HONG KONG) LTD.

Device Sales Division, 17/F, Admiralty Centre, Tower 1,  
18 Harcourt Road, Hong Kong  
PHONE : (852) 28229311  
FAX : (852) 28660779  
<http://www.sharp.com.hk>

**Shenzhen Representative Office**  
Room 13B1, Tower C,  
Electronics Science & Technology Building,  
Shen Nan Zhong Road, Shenzhen, P.R. China  
PHONE : (86) 755-83273731  
FAX : (86) 755-83273735

#### SHARP ELECTRONIC COMPONENTS (TAIWAN) CORPORATION

8F-A, No. 16, Sec. 4, Nanking E. Rd., Taipei, Taiwan  
PHONE : (886) 2-2577-7341  
FAX : (886) 2-2577-7326/2-2577-7328

#### SHARP ELECTRONICS (SINGAPORE) PTE., LTD.

396 Alexandra Road, UOB  
Alexandra Building, #07-00, Singapore 119954  
PHONE : (65) 6271-3566  
FAX : (65) 6271-3855  
<http://www.sesl-sharp.com>

#### SHARP MICROELECTRONICS TECHNOLOGY (M) SDN BHD.

1A Persiaran Kuala Longat, Section 27  
40400 Shah Alam, Selangor Darul Ehsan, Malaysia  
PHONE : (60) 3-5192-5692  
FAX : (60) 3-5192-9971

#### SHARP ELECTRONIC COMPONENTS (KOREA) CORPORATION

5F, Jeil Pharm B/D, 745-5,  
Banpo1-dong, Seocho-ku, Seoul 137-810 Korea  
PHONE : (82) 2-711-5813  
FAX : (82) 2-711-5819

The circuit application examples in this publication are provided to explain representative applications of SHARP devices and are not intended to guarantee any circuit design or license any intellectual property right. SHARP takes no responsibility for any problems related to any intellectual property right of a third party resulting from the use of SHARP devices.

SHARP reserves the right to make changes in the specifications, characteristics, data, materials, structures and other contents described herein at any time without notice in order to improve design or reliability.

Contact SHARP in order to obtain the latest device specification sheets before using any SHARP device. Manufacturing locations are also subject to change without notice.

In the absence of confirmation by device specification sheets, SHARP takes no responsibility for any defects that occur in equipment using any SHARP devices shown in catalogs, data books, etc.

Observe the following points when using any device in this publication. SHARP takes no responsibility for change caused by improper use of the devices, which does not meet the conditions and absolute maximum ratings for use specified in the relevant specification sheet nor meet the following conditions :

- The devices in this publication are designed for use in general electronic equipment designs such as :
  - Personal computers
  - Office automation equipment
  - Telecommunication equipment (except for trunk lines)
  - Test and measurement equipment
  - Industrial control
  - Audio visual equipment
  - Consumer electronics

- Measures such as fail-safe function and redundant design should be taken to ensure reliability and safety when SHARP devices are used for or in connection with equipment that requires higher reliability such as :

- Main frame computers
- Transportation control and safety equipment (i.e. aircraft, trains, automobiles, etc.)
- Traffic signals
- Gas leakage sensor breakers
- Alarm equipment
- Various safety devices, etc.

- SHARP devices shall not be used for or in connection with equipment that requires an extremely high level of reliability and safety such as :

- Military and aerospace applications
- Telecommunication equipment (trunk lines)
- Nuclear power control equipment
- Medical and other life support equipment (e.g., scuba)



If the SHARP devices listed in the publication fall within the scope of strategic products described in the Foreign Exchange and Foreign Trade Law of Japan, it is necessary to obtain approval to export such SHARP devices.

This publication is the proprietary product of SHARP and is copyrighted, with all rights reserved. Under the copyright laws, no part of this publication may be reproduced or transmitted in any form or by any means, electronic or mechanical for any purpose, in whole or in part, without the express written permission of SHARP. Express written permission is also required before any use of this publication may be made by a third party.

Contact and consult with a SHARP representative if there are any questions about the contents of this publication.

## Looking for pricing, stock, or lifecycle information?

Click below to explore more details on WIN SOURCE:

-  [View LR36689U on WIN SOURCE](#)
-  [Sharp Microelectronics Information](#)

## Optimize Your Supply Chain with WIN SOURCE Solutions

-  Global Sourcing Solution
-  Obsolete Management
-  Cost Control Management
-  Shortage Management
-  Alternative Solution
-  Excess Inventory Management