



**THE DATASHEET OF
LT1034IS8-1.2#PBF**



FEATURES

- **Guaranteed 20 ppm/°C Drift**
- **Guaranteed 40 ppm/°C Drift (SO-8 Package)**
- **20 μ A to 20mA Operation (1.2V)**
- Dynamic Impedance: 1 Ω
- 7V, 100 μ A Reference

APPLICATIONS

- Portable Meters
- Precision Regulators
- Calibrators

DESCRIPTION

The LT[®]1034 is a micropower, precision 1.2V/2.5V reference combined with a 7V auxiliary reference. The 1.2V/2.5V reference is a trimmed, thin-film, band-gap, voltage reference with 1% initial tolerance and guaranteed 20ppm/°C temperature drift. Operating on only 20 μ A, the LT1034 offers guaranteed drift, low temperature cycling hysteresis and good long-term stability. The low dynamic impedance makes the LT1034 easy to use from unregulated supplies. The 7V reference is a subsurface zener device for less demanding applications.

The LT1034 reference can be used as a high performance upgrade of the LM385 or LT1004, where guaranteed temperature drift is desired.

 LTC and LT are registered trademarks of Linear Technology Corporation.

TYPICAL APPLICATION

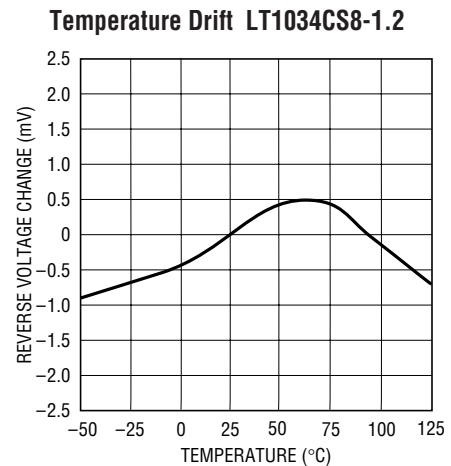
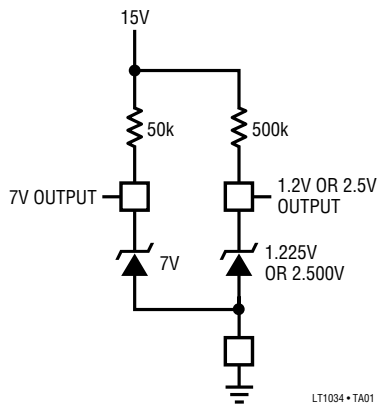

LT1034-1.2/LT1034-2.5

ABSOLUTE MAXIMUM RATINGS (Note 1)

Operating Current 20mA
 Forward Current (Note 2) 20mA
 Storage Temperature Range -65°C to 150°C
 Lead Temperature (Soldering, 10 sec)..... 300°C

Operating Temperature
 Commercial 0° to 70°C
 Industrial -40°C to 85°C
 Military (**OBSOLETE**) -55°C to 125°C

PACKAGE/ORDER INFORMATION

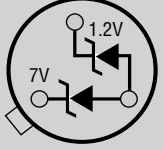
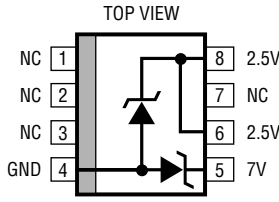
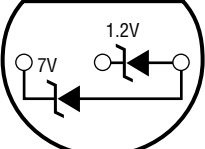
<p>BOTTOM VIEW</p>  <p>H PACKAGE 3-LEAD TO-46 METAL CAN $T_{JMAX} = 150^{\circ}\text{C}$, $\theta_{JA} = 440^{\circ}\text{C/W}$, $\theta_{JC} = 80^{\circ}\text{C/W}$</p> <p>OBSOLETE PACKAGE Consider the Z Package for Alternate Source</p>	<p>ORDER PART NUMBER</p> <p>LT1034BCH-1.2 LT1034BCH-2.5 LT1034BMH-1.2 LT1034BMH-2.5 LT1034CH-1.2 LT1034CH-2.5 LT1034MH-1.2 LT1034MH-2.5</p>	<p>TOP VIEW</p>  <p>S8 PACKAGE 8-LEAD PLASTIC SO</p> <p>$T_{JMAX} = 175^{\circ}\text{C}$, $\theta_{JA} = 150^{\circ}\text{C/W}$</p>	<p>ORDER PART NUMBER</p> <p>LT1034CS8-1.2 LT1034CS8-2.5 LT1034IS8-1.2 LT1034IS8-2.5</p>
<p>BOTTOM VIEW</p>  <p>Z PACKAGE 3-LEAD TO-92 PLASTIC $T_{JMAX} = 100^{\circ}\text{C}$, $\theta_{JA} = 160^{\circ}\text{C/W}$</p>	<p>ORDER PART NUMBER</p> <p>LT1034BCZ-1.2 LT1034BCZ-2.5 LT1034BIZ-1.2 LT1034BIZ-2.5 LT1034CZ-1.2 LT1034CZ-2.5 LT1034IZ-1.2 LT1034IZ-2.5</p>		<p>PART MARKING</p> <p>3401 3402 1034I12 34I02</p>

Consult LTC Marketing for parts specified with wider operating temperature ranges.

ELECTRICAL CHARACTERISTICS The ● denotes the specifications which apply over the full operating temperature range, otherwise specifications are at $T_A = 25^\circ\text{C}$.

PARAMETER	CONDITIONS		LT1034-1.2			LT1034-2.5			UNITS
			MIN	TYP	MAX	MIN	TYP	MAX	
Reverse Breakdown Voltage	$I_R = 100\mu\text{A}$	●	1.210	1.225	1.240	2.46	2.5	2.54	V
			1.205	1.225	1.245	2.43	2.5	2.57	V
Reverse Breakdown Change with Current	(Note 4) $2\text{mA} \leq I_R \leq 20\text{mA}$	●		0.5	2.0		1.0	3.0	mV
				1.0	4.0		1.5	6.0	mV
				4.0	8.0		6.0	16.0	mV
				6.0	15.0		10.0	20.0	mV
Minimum Operating Current		●	10	20		15	30	μA	
Temperature Coefficient	$I_R = 100\mu\text{A}$ LT1034B LT1034	●		10	20		10	20	ppm/ $^\circ\text{C}$
				20	40		20	40	ppm/ $^\circ\text{C}$
Reverse Dynamic Impedance (Note 3)	$I_R = 100\mu\text{A}$	●		0.25	1.0		0.5	1.5	Ω
				0.50	2.0		1.0	2.5	Ω
Low Frequency Noise	$I_R = 100\mu\text{A}$, $0.1\text{Hz} \leq F \leq 10\text{Hz}$	●		4			6	$\mu\text{V}_{\text{P-P}}$	
Long-Term Stability	$I_R = 100\mu\text{A}$			20			20	ppm/ $\sqrt{\text{kh}}$	

The ● denotes the specifications which apply over the full operating temperature range, otherwise specifications are at $T_A = 25^\circ\text{C}$.
7V Reference.

PARAMETER	CONDITIONS		MIN	TYP	MAX	UNITS
Reverse Breakdown Voltage	$I_R = 100\mu\text{A}$	●	6.80	7.0	7.3	V
			6.75	7.0	7.4	V
Reverse Breakdown Change with Current	$100\mu\text{A} \leq I_R \leq 1\text{mA}$	●		90	140	mV
	$100\mu\text{A} \leq I_R \leq 1\text{mA}$			100	190	mV
	$1\text{mA} \leq I_R \leq 20\text{mA}$			160	250	mV
	$1\text{mA} \leq I_R \leq 20\text{mA}$			200	350	mV
Temperature Coefficient	$I_R = 100\mu\text{A}$	●		40		ppm/ $^\circ\text{C}$
Long-Term Stability	$I_R = 100\mu\text{A}$			20		ppm/ $\sqrt{\text{kh}}$

Note 1: Absolute Maximum Ratings are those values beyond which the life of a device may be impaired.

Note 2: Forward biasing either diode will affect the operation of the other diode.

Note 3: This parameter guaranteed by “reverse breakdown change with current” test.

Note 4: For the LT1034-1.2: $20\mu\text{A} \leq I_R \leq 2\text{mA}$. For the LT1034-2.5: $30\mu\text{A} \leq I_R \leq 2\text{mA}$.

TYPICAL PERFORMANCE CHARACTERISTICS

Reverse Voltage Change 1.2V

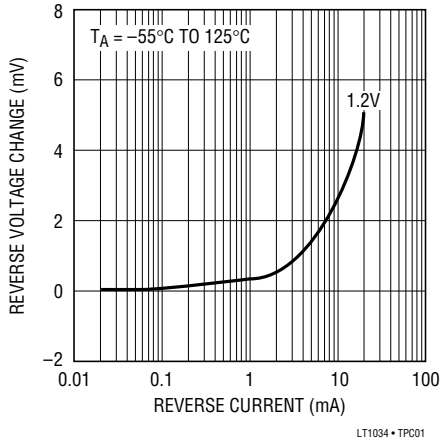

LT1034 • TPC01

Reverse Voltage Change 7V

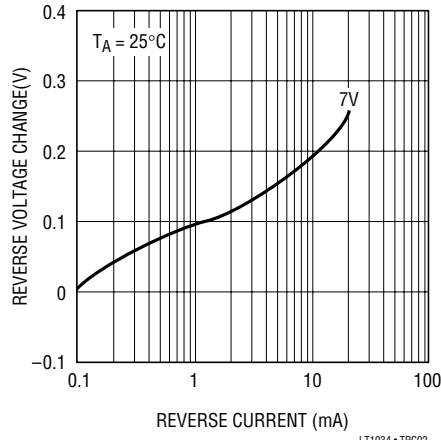

LT1034 • TPC02

0.1Hz to 10Hz Noise 1.2V

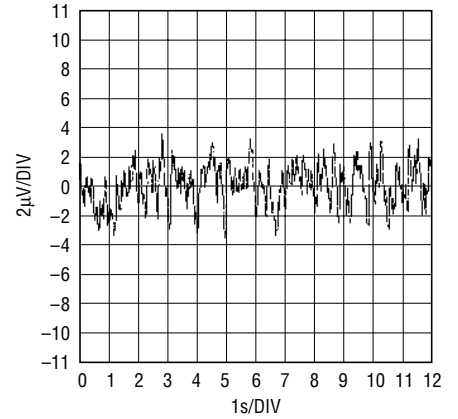

LT1034 • TPC03

Reverse Dynamic Impedance 1.2V

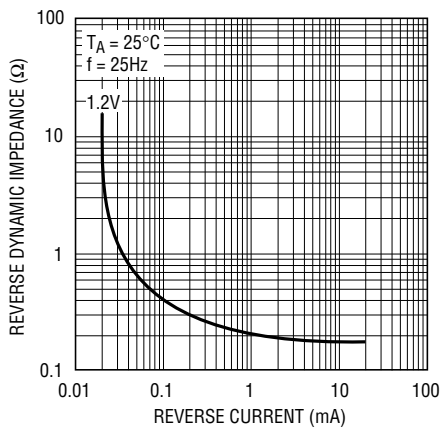

LT1034 • TPC04

Reverse Dynamic Impedance 2.5V

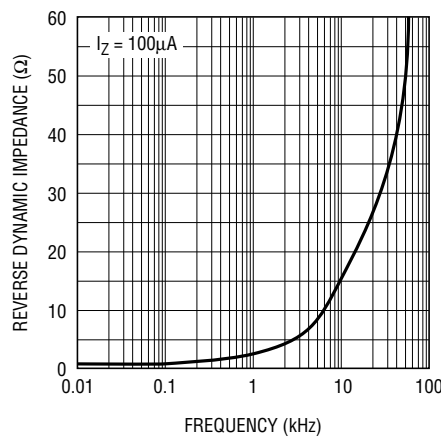

LT1034 • TPC05

Reverse Dynamic Impedance 7V

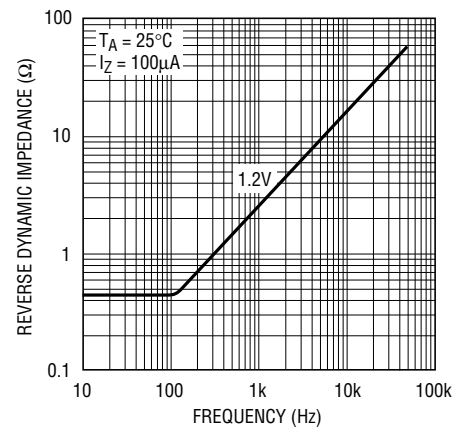

LT1034 • TPC06

TYPICAL PERFORMANCE CHARACTERISTICS

Reverse Characteristics 1.2V

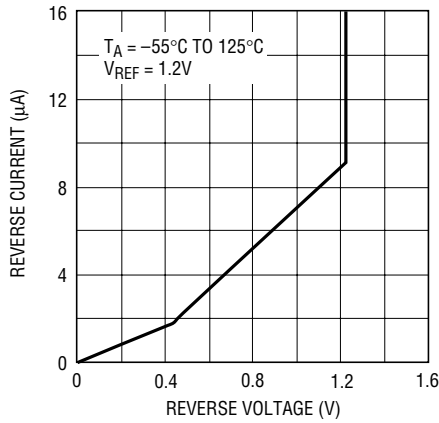

LT1034 • TPC07

Reverse Characteristics 2.5V

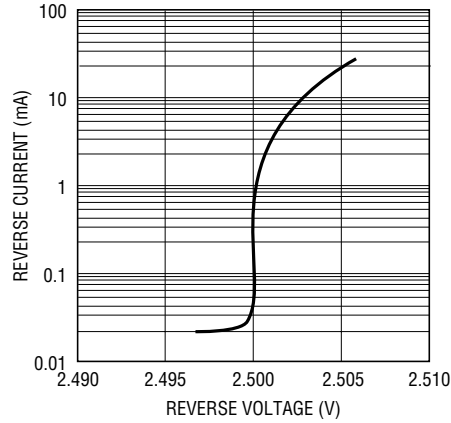

LT1034 • TPC02

Reverse Characteristics 7V

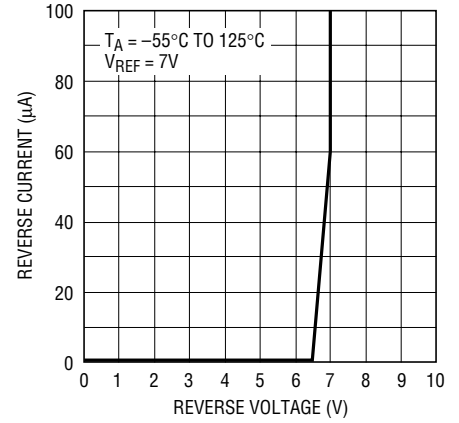

LT1034 • TPC09

Forward Characteristics

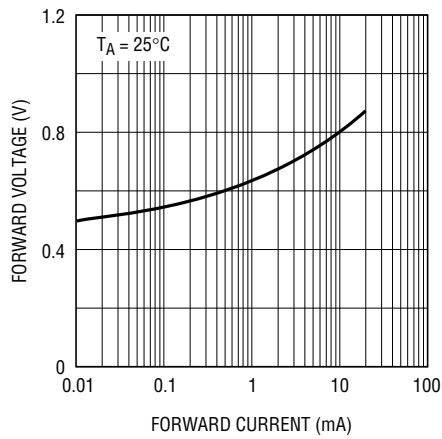

LT1034 • TPC10

Response Time

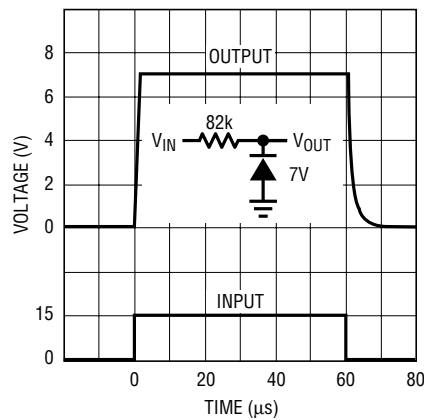

LT1180A • TPC11

Response Time

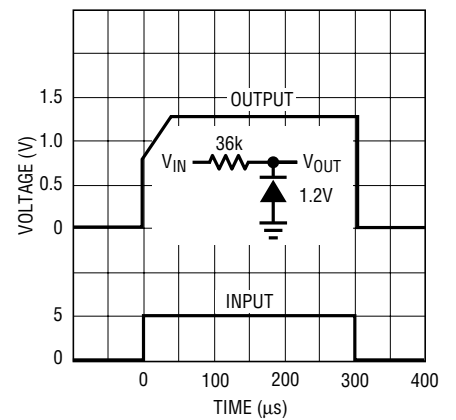

LT1180A • TPC12

PACKAGE DESCRIPTION

H Package
8-Lead TO-5 Metal Can (.200 Inch PCD)
 (Reference LTC DWG # 05-08-1320)

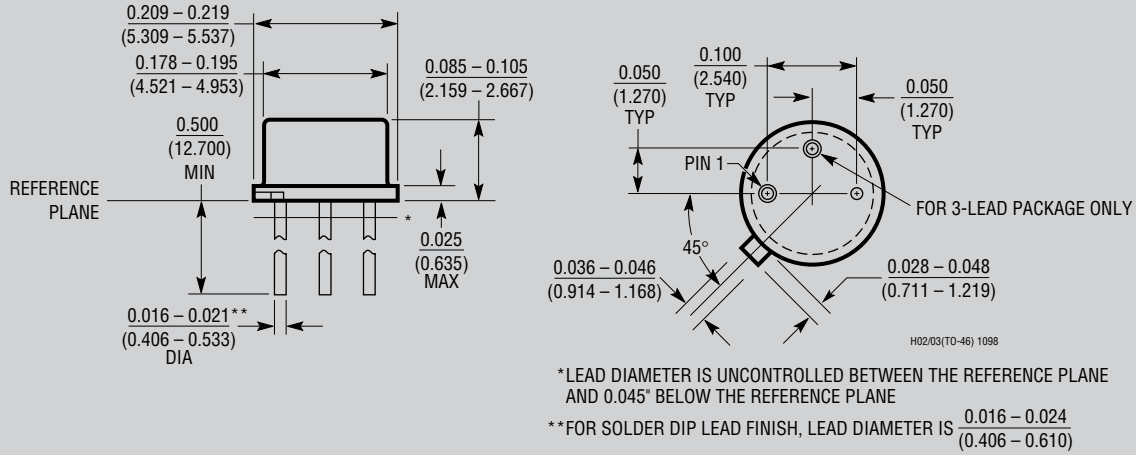

OBsolete PACKAGE

S8 Package
8-Lead Plastic Small Outline (Narrow .150 Inch)
 (Reference LTC DWG # 05-08-1610)

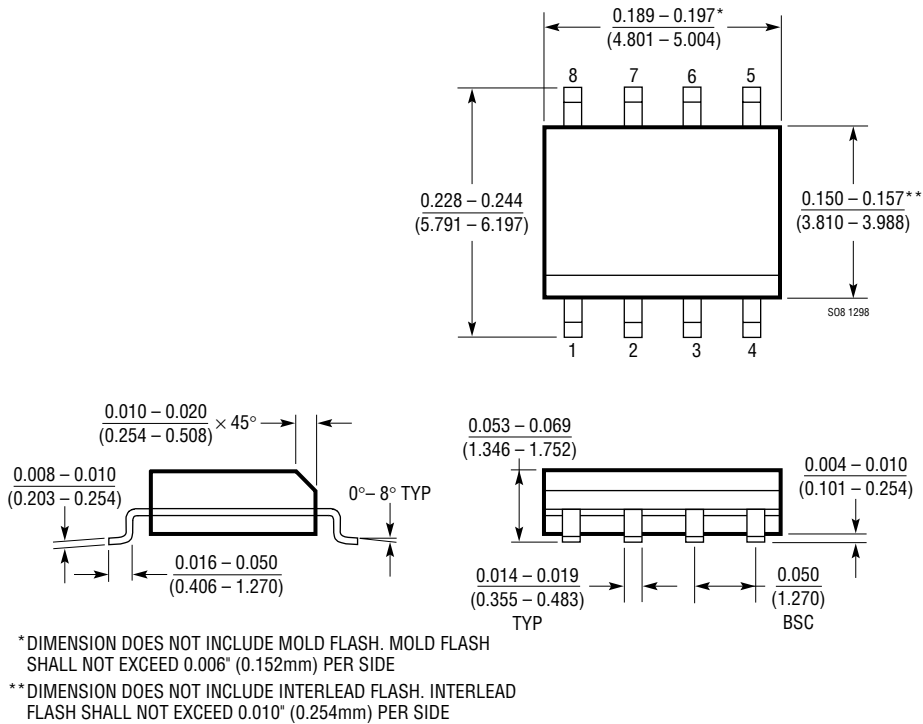

PACKAGE DESCRIPTION

Z Package
3-Lead Plastic TO-92 (Similar to TO-226)
 (Reference LTC DWG # 05-08-1410)

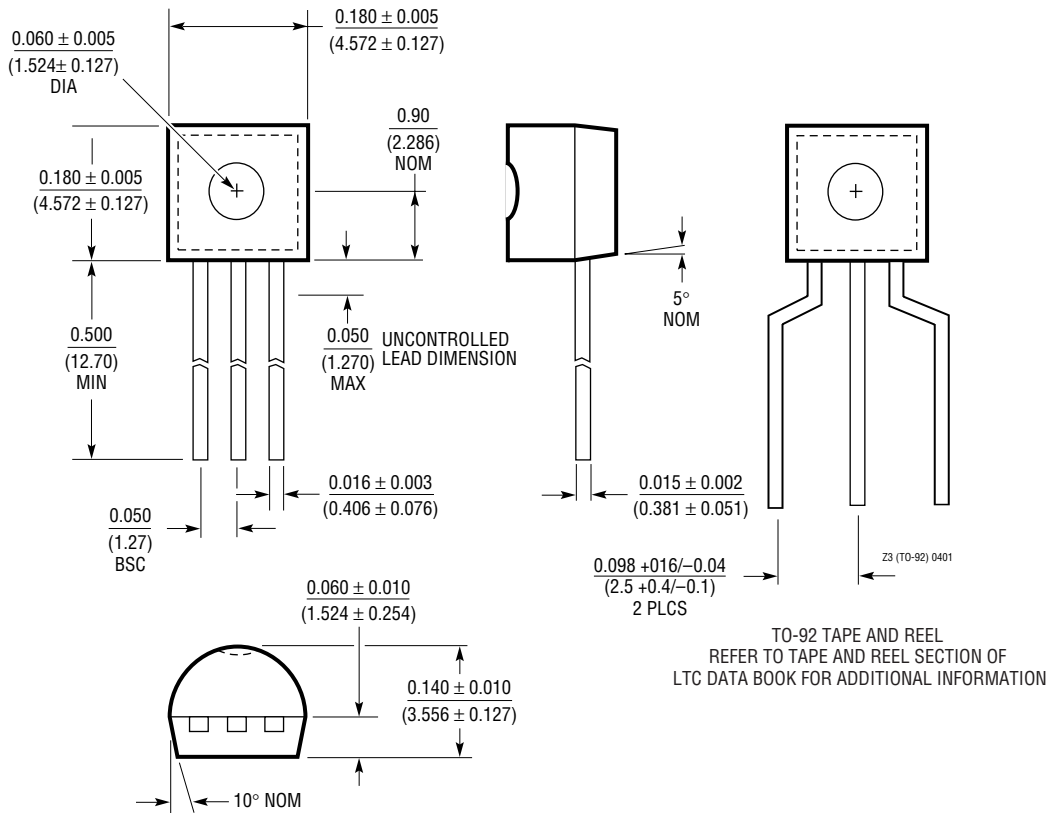

LT1034-1.2/LT1034-2.5

RELATED PARTS

PART NUMBER	DESCRIPTION	COMMENTS
LT1004	Low Cost Precision Band-Gap	Micropower, SO-8, Industrial Temperature Options
LT1019	Precision Series or Shunt Band-Gap	Low Dropout, Multiple Output Options
LT1236	Precision Series or Shunt Buried Zener	Low Noise, Low Power, Multiple Output Options

Looking for pricing, stock, or lifecycle information?

Click below to explore more details on WIN SOURCE:

 [View LT1034IS8-1.2#PBF on WIN SOURCE](#)

 [Linear Technology](#) Information

Optimize Your Supply Chain with WIN SOURCE Solutions

-  Global Sourcing Solution
-  Obsolete Management
-  Cost Control Management
-  Shortage Management
-  Alternative Solution
-  Excess Inventory Management