



**THE DATASHEET OF  
LT1036CT#PBF**



**OBSOLETE:**
**FOR INFORMATION PURPOSES ONLY**

Contact Linear Technology for Potential Replacement

## FEATURES

- Two Regulated Outputs:
  - 12V at 3A
  - 5V at 75mA
- 2% Output Voltage Tolerance
- 60dB Ripple Rejection
- 0.7% Load Regulation
- TTL and CMOS Compatible Logic Control
- 100% Thermal Burn-In on All Devices

## APPLICATIONS

- Power Supply Sequencing
- Remote On/Off Power Control
- Selective System Power During Emergency Power Operation
- Memory Power Supply with Back-Up

## DESCRIPTION

The LT<sup>®</sup>1036 features two positive regulators in the same package. The 12V main regulator offers excellent performance while supplying load currents up to 3A, and the 5V auxiliary regulator provides similar performance while supplying lighter loads of 75mA. The main regulator has the additional feature of being under the shutdown control of a logic signal. When the enable pin is taken to a low logic level, the main regulator shuts down and its output voltage goes to near 0V. During this command, the auxiliary output is unaffected by the main regulator's condition and continues to provide a 5V output.

The main output has current and power limiting combined with thermal shutdown to make it virtually blowout proof. The auxiliary output is not affected by the thermal shut down mechanism or the state of the main output, allowing it to be used as a back-up in case of overloads or shorts on the main supply.

The logic input of the LT1036 (enable pin) has a 1.6V threshold and can be driven from a high source impedance. This allows it to be driven by most logic families, including TTL and CMOS.

For a dual 5V version of the LT1036, please see the LT1035 data sheet.

 LTC and LT are registered trademarks of Linear Technology Corporation.

## TYPICAL APPLICATION

Functional Diagram

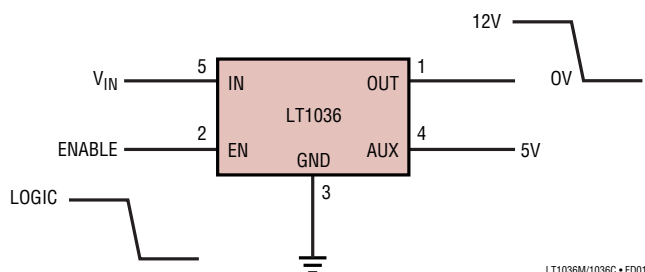
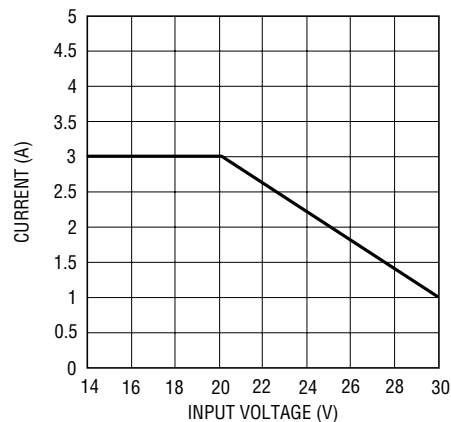
 Guaranteed Load Current,  
 12V Output

1036fb

# LT1036

## ABSOLUTE MAXIMUM RATINGS (Note 1)

Power Dissipation	Operating Junction Temperature
Continuous (Note 6) ..... 24W	LT1036M ..... -55°C to 150°C
Fault Conditions ..... Internally Limited	LT1036C ..... 0°C to 125°C
Input Voltage ( $V_{IN}$ ) ..... 30V	Storage Temperature Range ..... -65°C to 150°C
Enable Voltage ( $V_{EN}$ ) ..... 30V	Lead Temperature (Soldering, 10 sec) ..... 300°C

## PRECONDITIONING 100% Burn-In in Thermal Limit

## PACKAGE/ORDER INFORMATION

<p>BOTTOM VIEW</p> <p>K PACKAGE 4-LEAD TO-3 METAL CAN <math>T_{JMAX} = 125^{\circ}\text{C}</math>, <math>\theta_{JC} = 3^{\circ}\text{C/W}</math></p>	ORDER PART NUMBER	<p>FRONT VIEW</p> <p>T PACKAGE 5-LEAD PLASTIC TO-220 <math>T_{JMAX} = 150^{\circ}\text{C}</math>, <math>\theta_{JC} = 2.5^{\circ}\text{C/W}</math> <math>T_{JMAX} = 125^{\circ}\text{C}</math>, <math>\theta_{JC} = 2.5^{\circ}\text{C/W}</math></p>	ORDER PART NUMBER
	LT1036MK LT1036CK		LT1036CT

Consult LTC Marketing for parts specified with wider operating temperature ranges.

## ELECTRICAL CHARACTERISTICS

The ● denotes the specifications which apply over the full operating temperature range. Main regulator (Note 2)  $V_{IN} = 15\text{V}$  unless otherwise noted.

SYMBOL	PARAMETER	CONDITIONS	MIN	TYP	MAX	UNITS
$V_O$	Output Voltage	$T_J = 25^{\circ}\text{C}$	11.76	12	12.24	V
	High	$15\text{V} \leq V_{IN} \leq 30\text{V}$ , $I_{OUT} \leq I_{MAX}$ (Note 7)	● 11.52		12.48	V
	Low	$7\text{V} \leq V_{IN} \leq 30\text{V}$	●	0.1	0.3	V
$\frac{\Delta V_O}{\Delta I_O}$	Load Regulation (Note 7)	$V_{IN} = 16\text{V}$ $0 \leq I_O \leq 3\text{A}$ (Note 3)	●	10	80	mV
$\frac{\Delta V_O}{\Delta V_{IN}}$	Line Regulation	$15\text{V} \leq V_{IN} \leq 30\text{V}$ (Note 3)		1	4	mV/V
	Ripple Rejection	$50\text{Hz} \leq f \leq 500\text{Hz}$ (Note 9)	50	60		dB
	Thermal Regulation	$\Delta P_D = 20\text{W}$ (Note 5)		0.003	0.012	%/W
$I_O$	Available Load Current (Note 7)	$15\text{V} \leq V_{IN} \leq 20\text{V}$	● 3	4		A
		$V_{IN} = 25\text{V}$	● 2	2.7		A
$I_{SC}$	Short Circuit Current	$V_{IN} = 15\text{V}$		2.3	4	A
		$V_{IN} = 25\text{V}$		1	2	A
$V_{IN}$	Input Voltage to Maintain Regulation (Dropout Voltage)	(Note 6)	●	13.8	14.5	V
		$I_O = 1\text{A}$ $I_O = 3\text{A}$	●	14.4	15	V

1036fb

**ELECTRICAL CHARACTERISTICS** The ● denotes the specifications which apply over the full operating temperature range. Main Regulator (Note 2)  $V_{IN} = 15V$  unless otherwise noted.

SYMBOL	PARAMETER	CONDITIONS	MIN	TYP	MAX	UNITS
$I_Q$	Quiescent Current	Output High		4	5.5	mA
		Output Low		3	4.5	mA
$\theta_{JC}$	Thermal Resistance, Junction to Case	T0-220		2	3	°C/W

**Auxiliary Regulator (Note 2)**

SYMBOL	PARAMETER	CONDITIONS	MIN	TYP	MAX	UNITS
$V_O$	Output Voltage	$T_J = 25^\circ C$	4.9	5.0	5.1	V
		$7.2V \leq V_{IN} \leq 30V$ $0mA \leq I_O \leq 75mA$	● 4.8	5.0	5.2	V
$\frac{\Delta V_O}{\Delta I_O}$	Load Regulation	$7.2V \leq V_{IN} \leq 30V$ $0mA \leq I_O \leq 75mA$ (Note 3)	●	5	15	mV
$\frac{\Delta V_O}{\Delta V_{IN}}$	Line Regulation	$7.2V \leq V_{IN} \leq 30V$ (Note 3)		0.2	1	mV/V
					2	mV/V
	Ripple Rejection	$50Hz \leq f \leq 500Hz$		74		dB
$I_{SC}$	Short Circuit Current (Note 8)	$7.0V \leq V_{IN} \leq 30V$		140	250	mA
$V_{IN}$	Input Voltage to Maintain Regulation (Dropout Voltage)	(Note 6) $I_O \leq 10mA$	● 6.2	6.5		V
		$I_O = 75mA$	● 6.8	7.2		V

**Logic Control (Note 2)**

SYMBOL	PARAMETER	CONDITIONS	MIN	TYP	MAX	UNITS	
$V_{EN}$	Enable Threshold Voltage	$7.0V \leq V_{IN} \leq 30V$		1.45	1.6	1.7	V
		$T_J = 25^\circ C$	●	1.3	1.6	1.8	V
	Enable Pin Current	$V_{EN} \leq 1V$ (Note 4)	●	0	1.5	12	μA
		$V_{EN} \leq 2.4V$	●		0	6	μA

**Note 1:** Absolute Maximum Ratings are those values beyond which the life of a device may be impaired.

**Note 2:** Unless otherwise indicated, these specifications apply for  $V_{IN} = 15V$ ,  $I_O = 0mA$ , and  $T_J = 25^\circ C$ .

**Note 3:** Line and load regulation is measured using a low duty cycle pulse, causing little change in the junction temperature. Effects due to thermal gradients and device heating must be taken into account separately.

**Note 4:** When the enable pin is at a low logic level, current flows out of the enable pin.

**Note 5:** Pulse length for this measurement is 20ms.

**Note 6:** Input voltage is reduced until output drops by 100mV from its initial value.

**Note 7:** See "Guaranteed Load Current" graph.

**Note 8:** Continuous shorts on the auxiliary output are not allowed unless adequate heat sinking is used to maintain junction temperature below 150°C.

**Note 9:** Guaranteed but not tested.

# TYPICAL PERFORMANCE CHARACTERISTICS

**Minimum Input-Output Differential of Main Output**

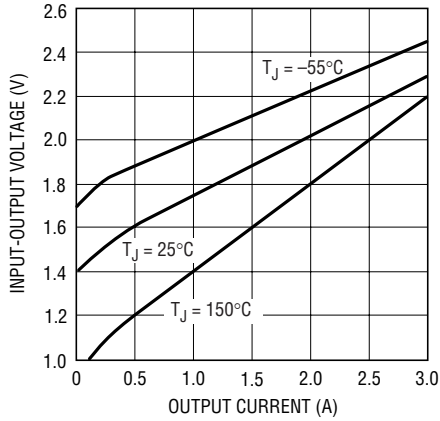

LT1036M/1036C • TPC01

**Minimum Input-Output Differential of Auxiliary Output**

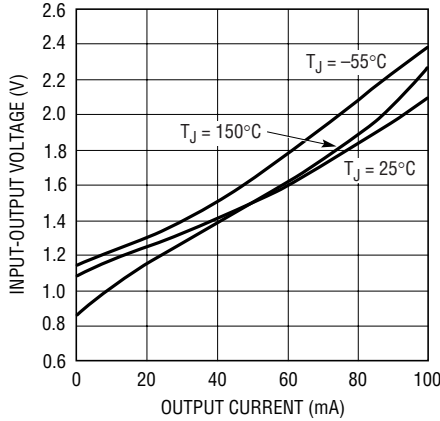

LT1036M/1036C • TPC02

**Line Transient Response, 12V Output**

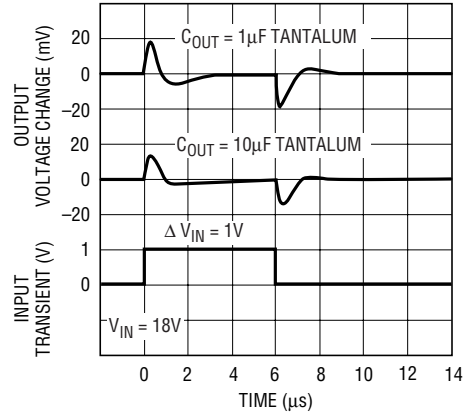

LT1036M/1036C • TPC03

**Maximum Available Load Current, 12V Output**

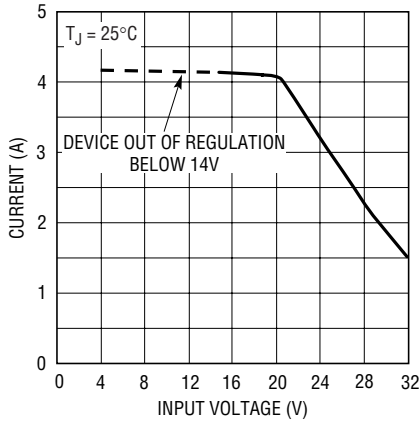

LT1036M/1036C • TPC04

**Quiescent Current**

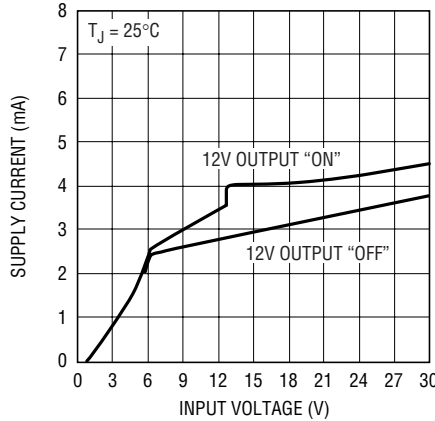

LT1036M/1036C • TPC05

**Output Voltage vs Temperature**

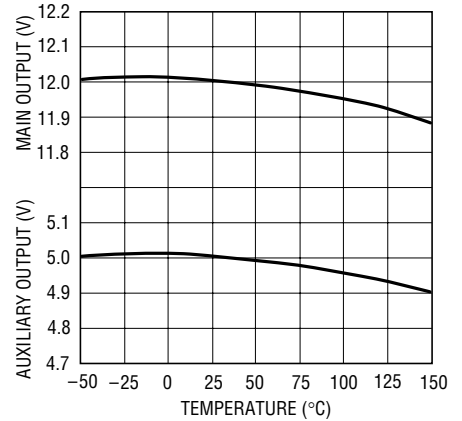

LT1036M/1036C • TPC06

**Load Transient Response, 12V Output**

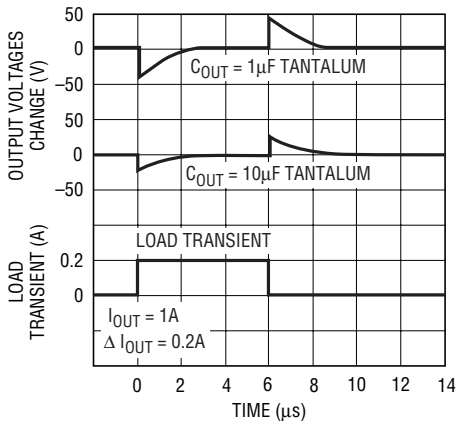

LT1036M/1036C • TPC07

**Enable Pin Characteristics**

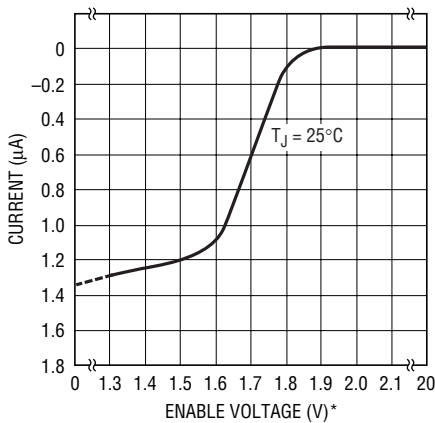

\*NOTE SCALE CHANGE

LT1036M/1036C • TPC08

**Enable Threshold**

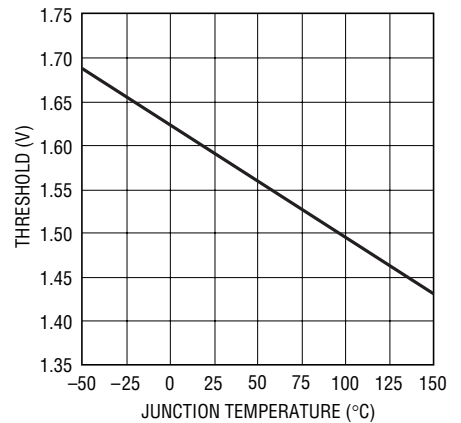

LT1036M/1036C • TPC09

## TYPICAL PERFORMANCE CHARACTERISTICS

### Short-Circuit Current, 12V Output

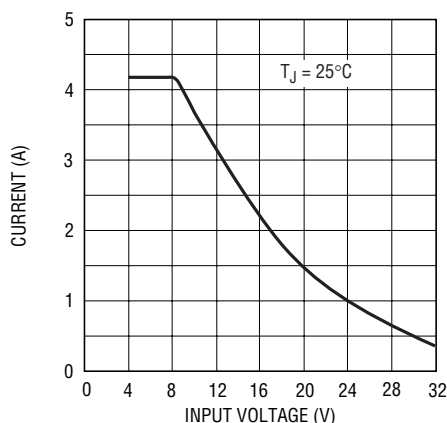

LT1036M/1036C • TPC10

### Output Switching Characteristics

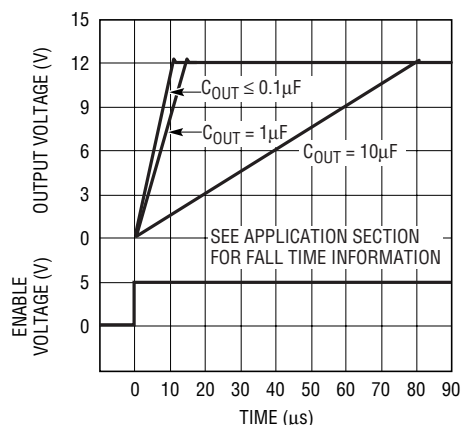

LT1036M/1036C • TPC11

### Output Voltage Noise

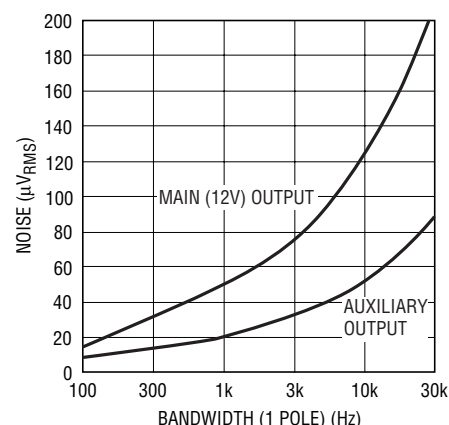

LT1036M/1036C • TPC12

## APPLICATIONS INFORMATION

### General Information

The LT1036 is a dual output regulator. The main 12V output is capable of delivering up to 3A of load current and can be shut down with a logic signal. The auxiliary 5V output supplies a minimum of 75mA and is unaffected by the logic signal. The outputs are trimmed to  $\pm 2\%$  initial tolerance and exhibit excellent line and load regulation.

The logic control feature makes the LT1036 ideal for many system applications where it is desirable to power-up a portion of the system for a period of time, and then power the system down during a standby operation. Applications such as multiple power supply sequencing, elimination of expensive AC and DC power switches, delayed start applications, switching 12V DC loads, and many others are now easily accomplished.

Timing functions, such as delayed power-up or power-down, can also be performed directly at the enable pin.

Because a logic low on the enable pin shuts down the main regulator, feedback from output to enable can be used to generate hysteresis or latching functions.

The low quiescent current drain of the LT1036 makes it useful in battery-powered or battery back-up applications. The enable pin can be used as a "low battery" detector or to shut down major portions of system power, allowing memory portions to continue to operate from the auxiliary output. At low output currents, the auxiliary output will regulate with input voltage typically as low as 6.2V, giving maximum battery life.

Good design practice with all regulators is to bypass the input and output terminals. A  $2\mu\text{F}$  solid tantalum at the input and at both outputs is suggested. For the applications which follow, the bypass capacitors are still recommended, but for simplicity are not shown on the diagram. It is also recommended that for maximum noise immunity the voltage enable pin be tied high if it is unused. It can be tied directly to  $V_{\text{IN}}$ , as shown in Figure 1, or to the auxiliary Output. If the enable pin is left open, it will float to a high logic level of approximately 1.6V and the main output regulator will be at 12V.

The enable pin is fully protected against input voltages up to 30V, even if the power input voltage is zero.

## APPLICATIONS INFORMATION

The basic shutdown control circuit uses a direct gate drive or an open collector driver and a pull-up resistor which are tied to  $V_{AUX}$ , as shown in Figure 2.

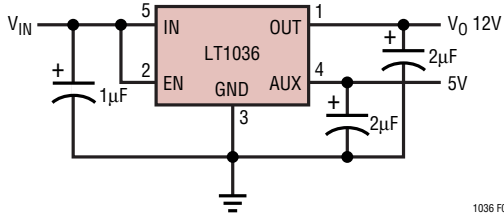

Figure 1

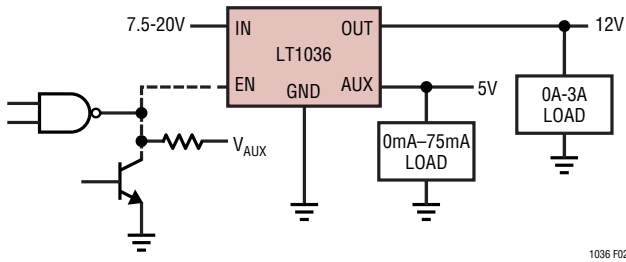

Figure 2

### Driving the Enable Pin

The enable pin equivalent schematic is shown in Figure 3. Basically, enable pin current is zero above the threshold and about  $1.5\mu\text{A}$  below the threshold, flowing out of the pin. Standard logic, such as TTL and CMOS, will interface directly to the enable pin, even if the logic output swing is higher than the input voltage ( $V_{IN}$ ) to the regulator. 15V CMOS can be used to drive the enable pin, even if the regulator is not powered up, without loading the CMOS output.

Timing functions, such as delayed power-up or power-down can be implemented with an RC network. The current flowing out of the enable pin should not

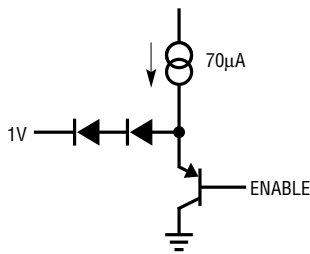

Figure 3

be used as the timing current in delayed power-up applications as it is temperature sensitive and varies somewhat from device to device. Instead, a resistor tied to the auxiliary output, the input, or to a logic signal should be used. The timing resistor chosen should provide at least  $25\mu\text{A}$  of current to “swamp out” the effects of the internal current.

### Main Output Current Voltage Characteristics

Following a high to low transition at the enable pin, the main regulator output will begin to drop after a delay of approximately  $0.4\mu\text{s}$ . With no capacitive load, the output will fall to zero in approximately  $0.8\mu\text{s}$  ( $R_L = 4\Omega$  to  $100\Omega$ ). With a capacitive load, fall time is limited by the RC product of the load and the output capacitance. For light loads ( $R_L > 400\Omega$ ), the discharge time is controlled by an internal current pull-down of 15mA for output voltages down to 1.5V. Below 1.5V, the pull-down current drops to  $\approx 4\text{mA}$ . The DC output voltage in the shutdown mode is approximately 0.12V due to an internal current path in the regulator. (See Figure 4.)

The user should note that the output in the low state can only sink about 3mA. If current is forced into the output, the output voltage will rise to 1V at 5mA and about 1.5V at 10mA. With no output capacitor, the rise time of the main output is about  $12\mu\text{s}$ . With an output capacitor, rise time is limited by the short circuit current of the LT1036 and the load capacitance. A  $10\mu\text{F}$  output capacitor slows the output rise time to approximately  $80\mu\text{s}$ .

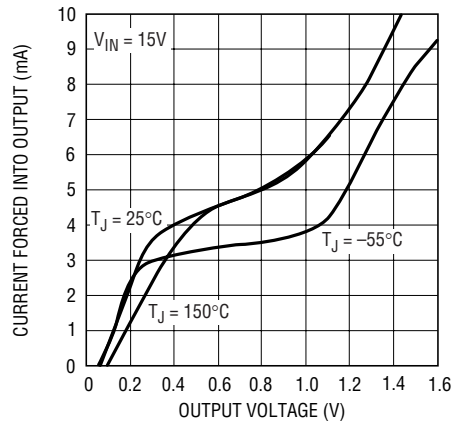

Figure 4

## APPLICATIONS INFORMATION

### Output Current

The main output current limits at about 4A for input voltages below 20V. Internal foldback, or “power limiting”, circuitry detects the input-output voltage differential and reduces current limit for input to output voltages exceeding 8V. With 25V input, for instance, short circuit current is reduced to  $\approx 0.9A$ .

An additional feature of the LT1036 is that the auxiliary supply does not incorporate, nor is it affected by, thermal shutdown. Any fault condition of the main regulator will not affect the auxiliary output voltage.

The following applications circuits will serve to indicate the versatility of the LT1036.

## TYPICAL APPLICATIONS

Fast Turn-Off, Delayed Turn-On

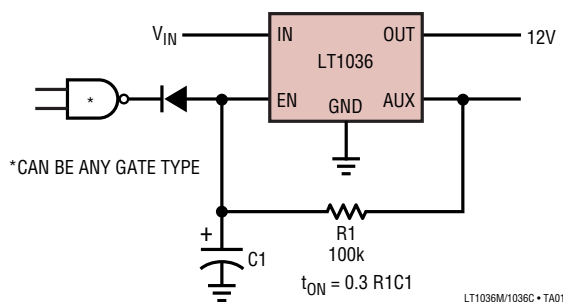

Latch-Off with Output Short

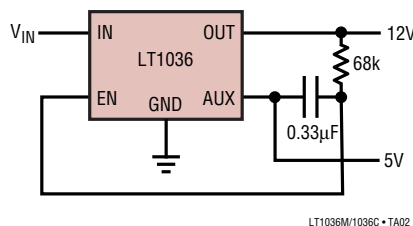

Delayed Power-Up

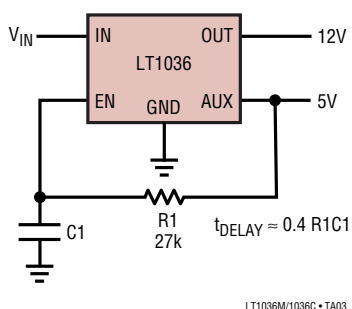

Thermal Cutoff at High Ambient Temperature

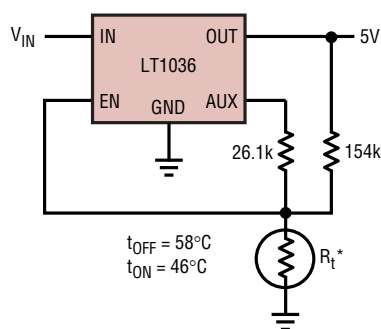

Power Supply Turn-On Sequencing

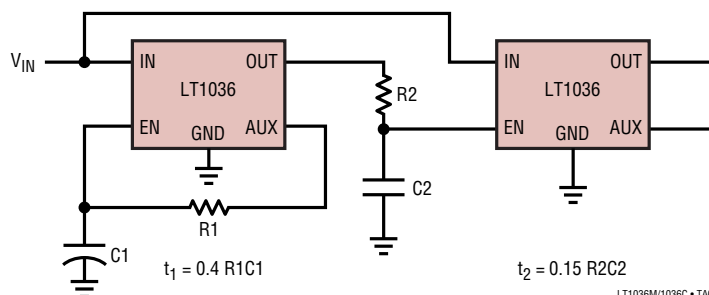

## TYPICAL APPLICATIONS

### First-On, Last-Off Sequencing

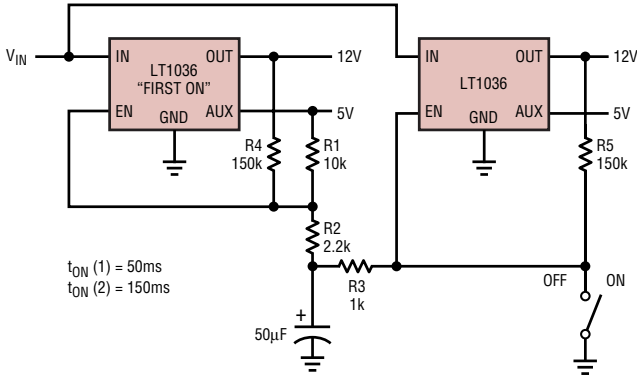

LT1036M/1036C • TA06

### First-On, First-Off Sequencing

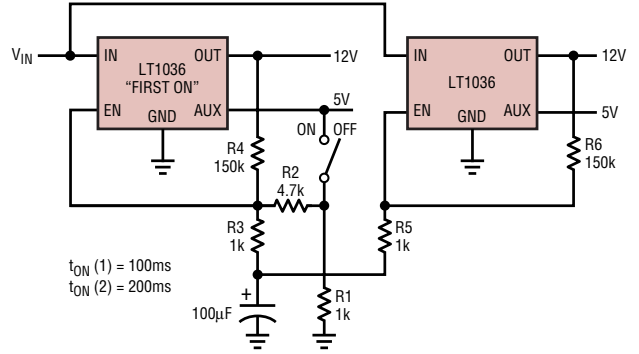

LT1036M/1036C • TA07

### Line Dropout Detector

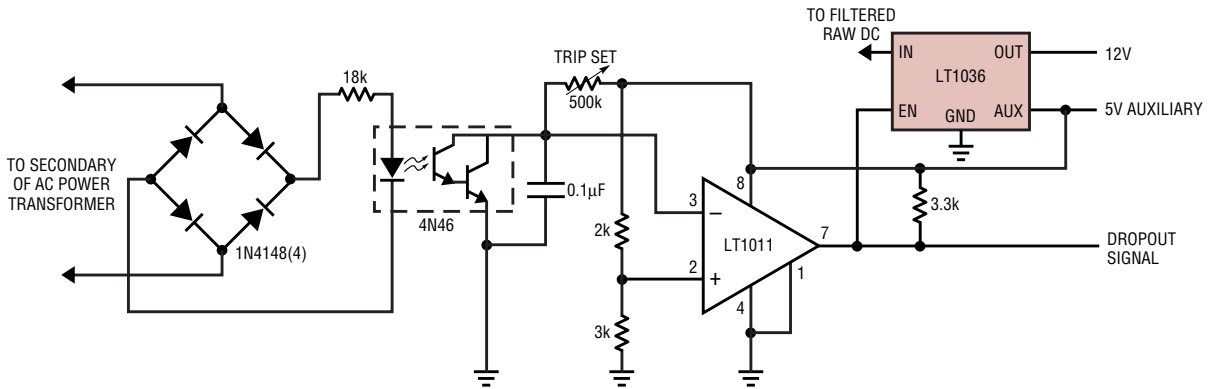

LT1036M/1036C • TA08

### Low Dissipation Regulator

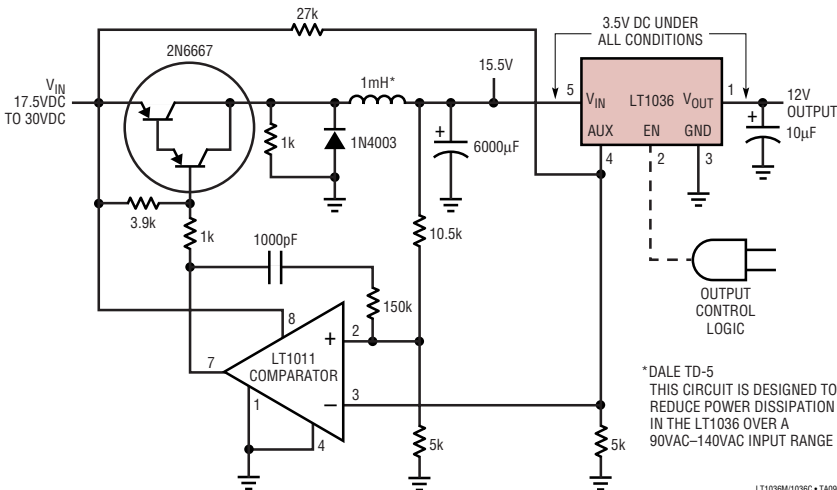

LT1036M/1036C • TA09

### Optocoupled Output Control

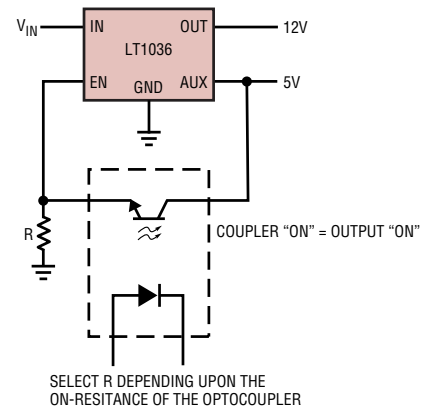

LT1036M/1036C • TA10



**PACKAGE DESCRIPTION**

**T Package**  
**5-Lead Plastic TO-220 (Standard)**  
 (Reference LTC DWG # 05-08-1421)

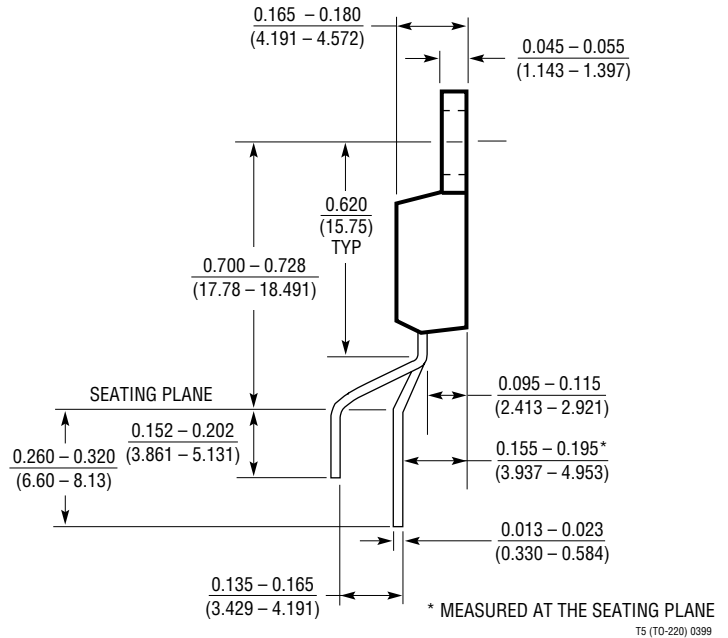
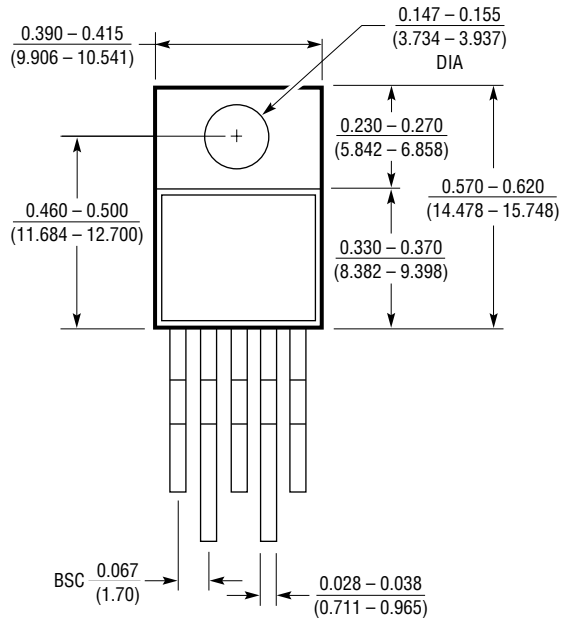

**PACKAGE DESCRIPTION**

**K Package**  
**4-Lead TO-3 Metal Can**  
 (Reference LTC DWG # 05-08-1311)

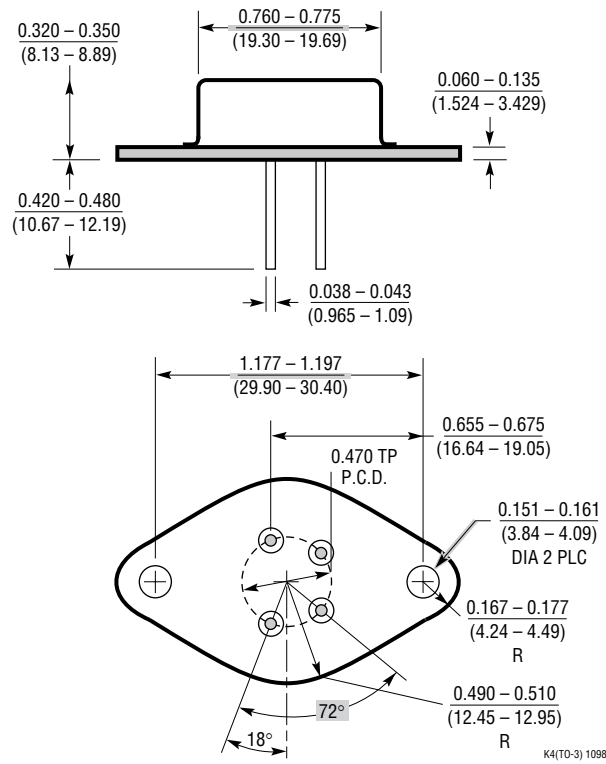

## RELATED PARTS

PART NUMBER	DESCRIPTION	COMMENTS
LT1573	UltraFast Transient Response Low Dropout Regulator PNP Driver, Up to 5A	$V_{IN}=2.8$ to 10V, $V_{OUT} = 1.265$ V, Dropout Voltage = 350mV-Ext PNP $V@I_{OUT}$ , $I_Q = 1.7$ mA, Shutdown Current = 200 $\mu$ A, S8 Package. Requires External PNP Transistor.
LT1764/A	3A, Low Noise, Fast Transient Response, LDO	$V_{IN} = 2.7$ to 20V, $V_{OUT} = 1.21$ V, Dropout Voltage = .34V@ $I_{OUT}$ , $I_Q = 1$ mA, Shutdown Current < 1 $\mu$ A, DD, TO220-5 Packages. Low Noise < 40 $\mu$ V <sub>RMS</sub> PK-PK. "A" Version Stable with Ceramic Capacitors.
LT3150	Fast Transient Response Low Dropout Regulator MOSFET Driver, Up to 10A	$V_{IN} = 1.4$ to 10V, $V_{OUT} = 1.23$ V, Dropout Voltage = 150mV Ext FET @ $I_{OUT}$ , $I_Q = 12$ mA, GN-16 Package. Intgr LT1613 Boost, Drives Low Cost N-Channel MOSFETs, Fast Transient Response.

## Looking for pricing, stock, or lifecycle information?

Click below to explore more details on WIN SOURCE:

 [View LT1036CT#PBF on WIN SOURCE](#)

 [Linear Technology](#) Information

## Optimize Your Supply Chain with WIN SOURCE Solutions

-  Global Sourcing Solution
-  Obsolete Management
-  Cost Control Management
-  Shortage Management
-  Alternative Solution
-  Excess Inventory Management