



**THE DATASHEET OF  
LT1120CN8#PBF**



# Micropower Regulator with Comparator and Shutdown

## FEATURES

- 40 $\mu$ A Supply Current
- 125mA Output Current
- 2.5V Reference Voltage
- Reference Output Sources 2mA and Sinks 2mA
- Open Collector Comparator Sinks 10mA
- Logic Shutdown
- 0.2V Dropout Voltage
- Thermal Limiting
- Available in 8-Lead DIP and SO Packages

## APPLICATIONS

- Battery Systems
- Battery-Backup System
- Portable Terminals
- Portable Instruments
- Memory Keep-Alive

## DESCRIPTION

The LT<sup>®</sup>1120 is a combination micropower positive regulator and free collector comparator on a single monolithic chip. With only 40 $\mu$ A supply current, the LT1120 can supply over 125mA of output current. Input voltage range is from 4.5V to 36V and dropout voltage is 0.6V at 125mA. Dropout voltage decreases with lower load currents. Also included on the chip is a class B output 2.5V reference that can either source or sink current. A shutdown pin allows logic shutdown of the output.

The comparator can be used for system or battery monitoring. For example, the comparator can be used to warn of low system voltage. Frequency compensation of the comparator for amplifier applications can be obtained by adding external output capacitance.

The 2.5V reference will source or sink current. This allows it to be used as a supply splitter or auxiliary output.

LT, LT, LTC and LTM are registered trademarks of Linear Technology Corporation. All other trademarks are the property of their respective owners.

## TYPICAL APPLICATION

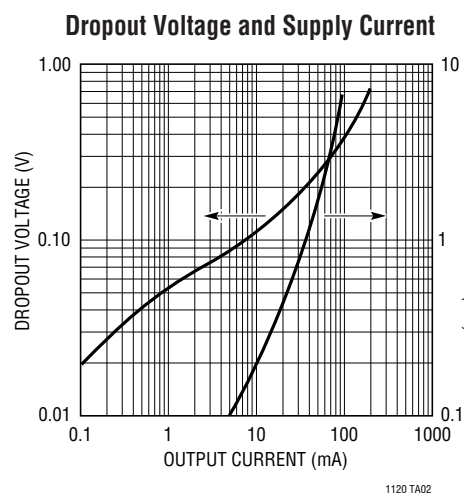
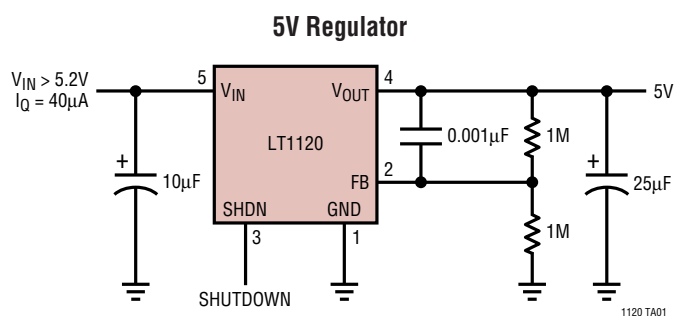

# LT1120

## ABSOLUTE MAXIMUM RATINGS (Note 1)

Input Voltage .....	36V	Operating Temperature Range	
NPN Collector Voltage .....	36V	LT1120C .....	0°C to 100°C
Output Short-Circuit Duration .....	Indefinite	LT1120I .....	-40 to 100°C
Power Dissipation .....	Internally Limited	Storage Temperature Range .....	-65°C to 150°C

## PACKAGE/ORDER INFORMATION

<p>N8 PACKAGE 8-LEAD PDIP S8 PACKAGE 8-LEAD PLASTIC SO T<sub>JMAX</sub> = 110°C, θ<sub>JA</sub> = 130°C/W (N) T<sub>JMAX</sub> = 110°C, θ<sub>JA</sub> = 150°C/W (S)</p>	ORDER PART NUMBER	<p>H PACKAGE 8-LEAD TO-5 METAL CAN T<sub>JMAX</sub> = 150°C, θ<sub>JA</sub> = 150°C/W, θ<sub>JC</sub> = 45°C/W</p>	ORDER PART NUMBER
	LT1120CN8 LT1120CS8 LT1120IN8 LT1120IS8		LT1120CH
	S8 PART MARKING		
	1120 1120I		
J8 PACKAGE 8-LEAD CERDIP T <sub>JMAX</sub> = 150°C, θ <sub>JA</sub> = 100°C/W (J)	ORDER PART NUMBER		
	LT1120CJ8		

**OBSOLETE PACKAGES**  
Consider the N8 and S8 Packages for Alternate Source

Consult LTC Marketing for parts specified with wider operating temperature ranges.

## ELECTRICAL CHARACTERISTICS

The ● denotes the specifications which apply over the full operating temperature range, otherwise specifications are at T<sub>A</sub> = 25°C. T<sub>J</sub> = 25°C.

PARAMETER	CONDITIONS	MIN	TYP	MAX	UNITS
<b>Reference</b>					
Reference Voltage	4.5V ≤ V <sub>IN</sub> ≤ 36V	2.46	2.50	2.54	V
Line Regulation	4.5V ≤ V <sub>IN</sub> ≤ 36V		0.01	0.015	%/V
Load Regulation	-2mA ≤ I <sub>REF</sub> ≤ 2mA, V <sub>IN</sub> = 12V		0.3	0.6	%
Output Source Current	V <sub>IN</sub> = 5V	2	4		mA
Output Sink Current	V <sub>IN</sub> = 5V	2	4		mA
Temperature Stability			1		%
<b>Regulator</b>					
Supply Current	V <sub>IN</sub> = 6V, I <sub>OUT</sub> ≤ 100μA V <sub>IN</sub> = 36V, I <sub>OUT</sub> ≤ 100μA V <sub>IN</sub> = 12V, I <sub>OUT</sub> = 125mA		45 75 11	80 100 20	μA μA mA
Output Current	(V <sub>IN</sub> - V <sub>OUT</sub> ) ≥ 1V, V <sub>IN</sub> ≥ 6V	125			mA
Load Regulation	(V <sub>IN</sub> - V <sub>OUT</sub> ) ≥ 1V, V <sub>IN</sub> ≥ 6V		0.2	0.5	%
Line Regulation	6V ≤ V <sub>IN</sub> ≤ 36V		0.01	0.015	%/V
Dropout Voltage	I <sub>OUT</sub> = 100μA I <sub>OUT</sub> = 125mA		0.02 0.4	0.05 0.65	V V

1120fd

**ELECTRICAL CHARACTERISTICS** The ● denotes the specifications which apply over the full operating temperature range, otherwise specifications are at  $T_A = 25^\circ\text{C}$ .  $T_j = 25^\circ\text{C}$ .

PARAMETER	CONDITIONS	MIN	TYP	MAX	UNITS
Feedback Sense Voltage	$V_{IN} = 12\text{V}$	2.44	2.5	2.56	V
Shutdown Pin Voltage	$V_{OUT} \leq 0.5\text{V}$	Normal		0.4	V
		Shutdown		2.2	1.4
Shutdown Pin Current	$V_{IN} = 1.4\text{V}$		25		$\mu\text{A}$
Feedback Bias Current			15	40	nA
Minimum Load Current	$V_{IN} = 36\text{V}$		1	5	$\mu\text{A}$
Short-Circuit Current	$V_{IN} = 36\text{V}$		300	400	mA

**Comparator**

Offset Voltage	$V_{IN} = 36\text{V}$		3	7	mV
Bias Current	$V_{IN} = 36\text{V}$ (Note 2)		15	40	nA
Gain	$\Delta V_{OUT} = 29\text{V}$ , $R_L = 20\text{k}$	2000	10000		V/V
Power Supply Rejection	$4.5\text{V} \leq V_S \leq 36\text{V}$	80	96		dB
Output Sink Current	$V_{IN} = 4.5\text{V}$	10	18		mA
Saturation Voltage	$I_{OUT} = 1\text{mA}$		0.4	0.6	V
Input Voltage Range		0		$V_{IN} - 1$	V
Response Time			5		$\mu\text{s}$
Leakage Current				2	$\mu\text{A}$

The ● denotes the specifications which apply over the full operating temperature range, otherwise specifications are at  $T_A = 25^\circ\text{C}$ .

PARAMETER	CONDITIONS		MIN	TYP	MAX	UNITS
<b>Reference</b>						
Reference Voltage	$4.5\text{V} \leq V_{IN} \leq 36\text{V}$	●	2.40	2.50	2.55	V
Line Regulation	$4.5\text{V} \leq V_{IN} \leq 36\text{V}$	●		0.01	0.02	%/V
Load Regulation	$-2\text{mA} \leq I_{REF} \leq 2\text{mA}$ , $V_{IN} = 12\text{V}$	●		0.4	0.8	%
Output Source Current	$V_{IN} = 5\text{V}$	●	2			mA
Output Sink Current	$V_{IN} = 5\text{V}$	●	2			mA

**Regulator**

Supply Current	$V_{IN} = 6\text{V}$ , $I_{OUT} \leq 100\mu\text{A}$	●		65	95	$\mu\text{A}$
	$V_{IN} = 36\text{V}$ , $I_{OUT} \leq 100\mu\text{A}$	●		85	100	$\mu\text{A}$
	$V_{IN} = 12\text{V}$ , $I_{OUT} = 125\text{mA}$	●		11	20	mA
Output Current	$(V_{IN} - V_{OUT}) \geq 1\text{V}$ , $V_{IN} \geq 6\text{V}$	●	125			mA
Load Regulation	$(V_{IN} - V_{OUT}) \geq 1\text{V}$ , $V_{IN} \geq 6\text{V}$	●			1	%
Line Regulation	$6\text{V} \leq V_{IN} \leq 36\text{V}$	●			0.02	%/V
Dropout Voltage	$I_{OUT} = 100\mu\text{A}$	●			0.06	V
	$I_{OUT} = 125\text{mA}$	●			0.85	V
Feedback Sense Voltage	$V_{IN} = 12\text{V}$	●	2.38	2.5	2.57	V
Feedback Bias Current		●			50	nA
Minimum Load Current	$V_{IN} = 36\text{V}$	●			50	$\mu\text{A}$
Short-Circuit Current	$V_{IN} = 36\text{V}$	●		300	400	mA

## ELECTRICAL CHARACTERISTICS

The ● denotes the specifications which apply over the full operating temperature range, otherwise specifications are at  $T_A = 25^\circ\text{C}$ .

PARAMETER	CONDITIONS	MIN	TYP	MAX	UNITS
<b>Comparator</b>					
Offset Voltage		●		10	mV
Bias Current	$V_{IN} = 36\text{V}$ (Note 2)	●	15	60	nA
Gain	$\Delta V_{OUT} = 29\text{V}$ , $R_L = 20\text{k}$	●	1000		V/V
Output Sink Current	$V_{IN} = 4.5\text{V}$ (Note 3)	●	5	10	mA
Leakage Current	$V_{IN} = 36\text{V}$	●		8	$\mu\text{A}$

**Note 1:** Stresses beyond those listed under Absolute Maximum Ratings may cause permanent damage to the device. Exposure to any Absolute Maximum Rating condition for extended periods may affect device reliability and lifetime.

**Note 2:**  $T_A > 85^\circ\text{C}$ , I bias maximum is 100nA.

**Note 3:** For  $T_A \leq -40^\circ\text{C}$  output current sink drops to 2.5mA.

## TYPICAL PERFORMANCE CHARACTERISTICS

**Regulator Load Regulation**

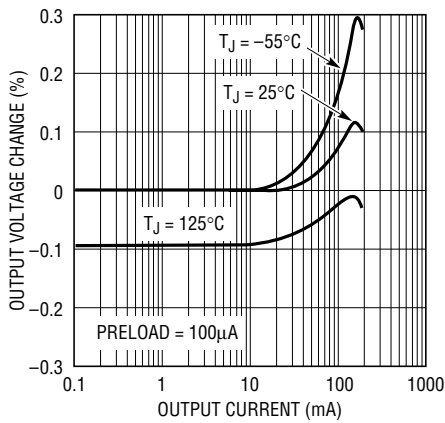

**Supply Current**

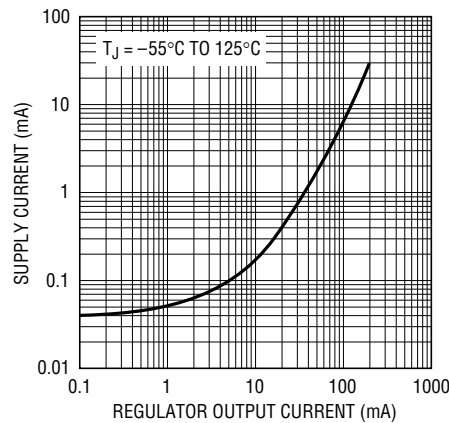

**Regulator Short-Circuit Current**

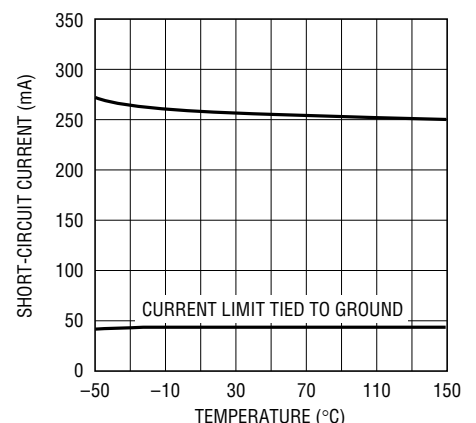

**Dropout Voltage**

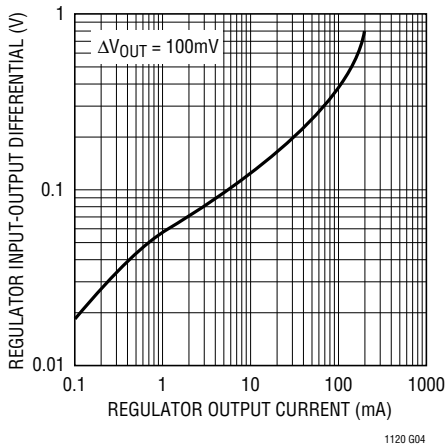

**Regulator Minimum Load Current**

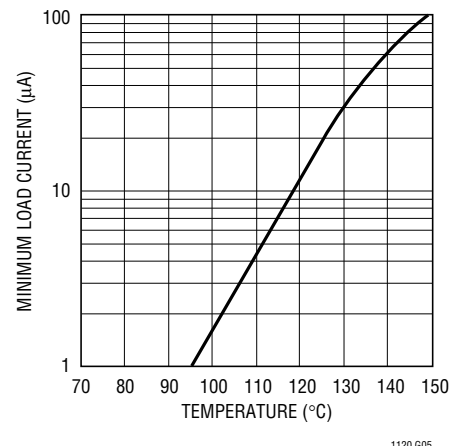

**Regulator Ripple Rejection**

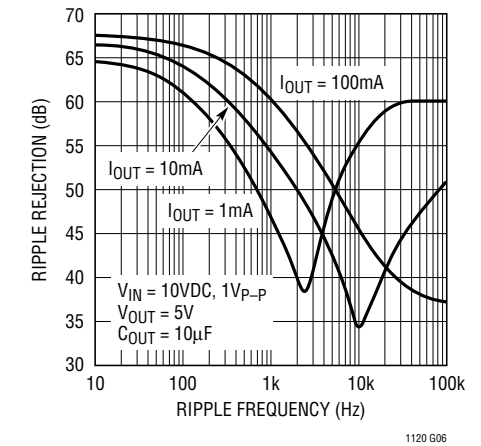

# TYPICAL PERFORMANCE CHARACTERISTICS

**Supply Current**

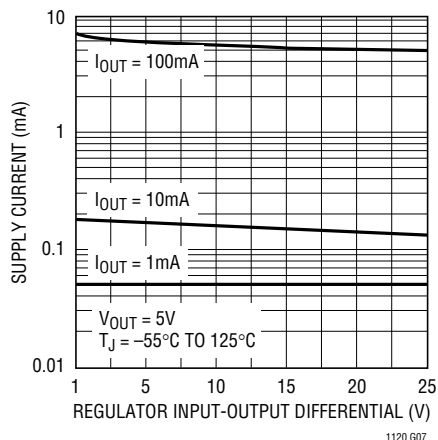

**Supply Current at Dropout**

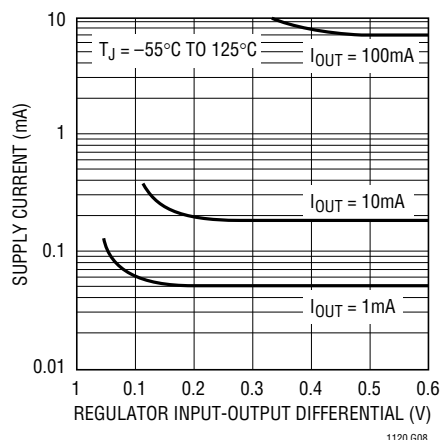

**Reference Regulation**

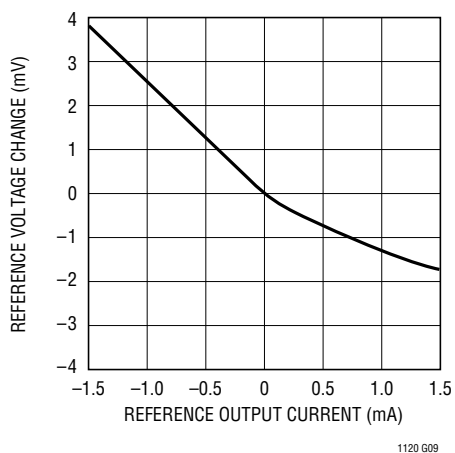

**Feedback Pin Current**

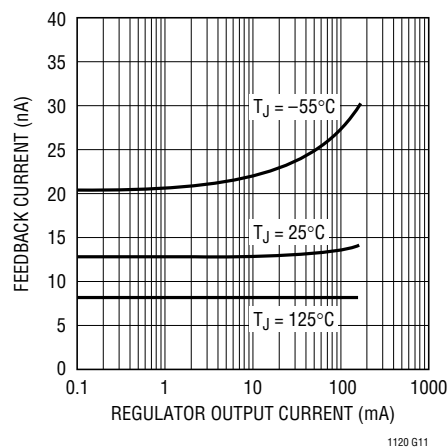

**Regulator Thermal Regulation**

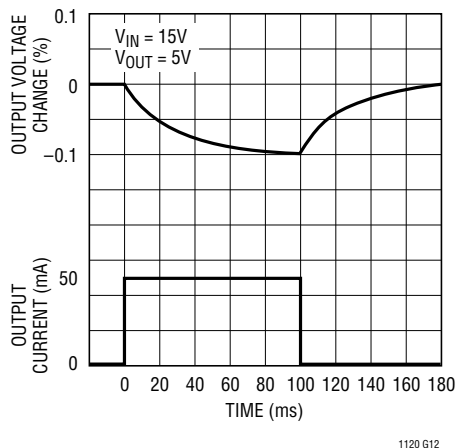

**LT1120 Turn-On Characteristic**

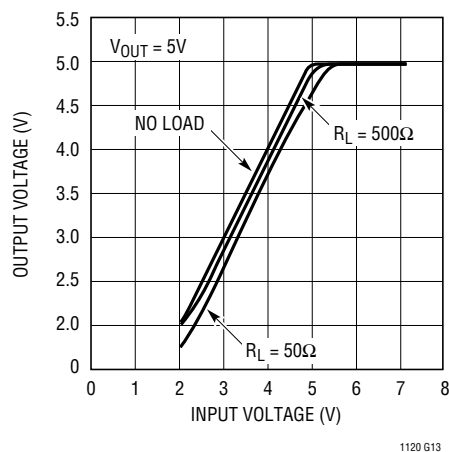

## PIN FUNCTIONS

**GND (Pin 1):** Ground.

**FB (Pin 2):** Feedback. This is the feedback point of the regulator. When operating, it is nominally at 2.5V. Optimum source resistance is 200k to 500k. The feedback pin should not be driven below ground or more positive than 5V.

**SHDN (Pin 3):** Shutdown. A logic 1 shuts off the main regulator. Caution: noise or leakage into the shutdown pin can affect output voltage.

**V<sub>OUT</sub> (Pin 4):** Regulator Output. Main output, requires a 10 $\mu$ F output capacitor. Can be shorted to V<sub>IN</sub> or ground without damaging the device.

**V<sub>IN</sub> (Pin 5):** Input Supply. Bypass with a 10 $\mu$ F capacitor. Must always be more positive than ground.

**REF (Pin 6):** Reference. 2.5V can source or sink current. May be shorted to ground or up to 5V. Voltages in excess of 5V can damage the device.

**COMPOUT (Pin 7):** Comparator Output. Open Collector NPN Output. May be connected to any voltage from ground to 36V more positive than ground (operates above V<sub>IN</sub>). Short-circuit protected.

**–INPUT (Pin 8):** Comparator Input. Inverting comparator input.

## BLOCK DIAGRAM

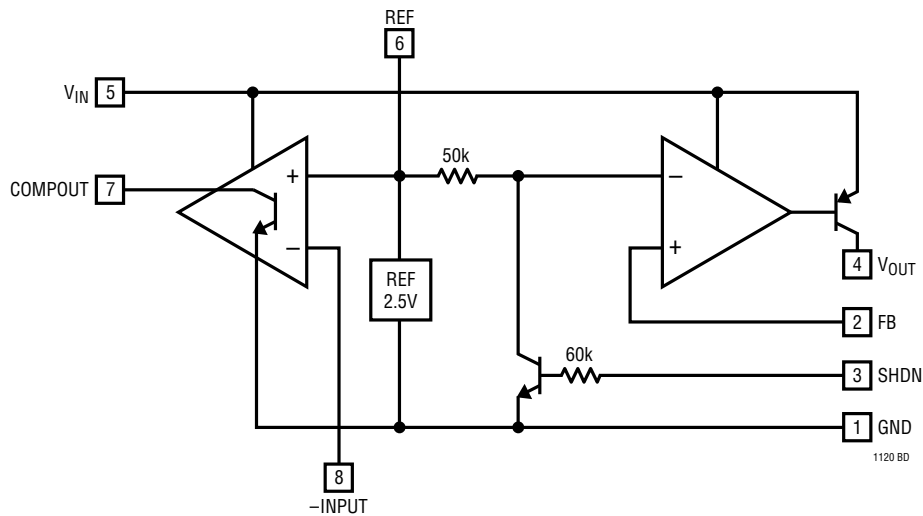

## APPLICATIONS INFORMATION

The LT1120 is especially suited for micropower system applications. For example, the comparator section of the LT1120 may be used as a battery checker to provide an indication of low battery. Another type of system application for the LT1120 would be to generate the equivalent of split supplies off of a single power input. The regulator section provides regulated output voltage and the reference, which can both source and sink current, is then an artificial system ground providing a split supply for the system.

For many applications the comparator can be frequency compensated to operate as an amplifier. Compensation values for various gains are given in the data sheet. The comparator gain is purposely low to make it easier to frequency compensate as an amplifier. The NPN output is capable of sinking 10mA and can drive loads connected to voltages in excess of the positive power supply. This is useful for driving switches or linear regulators off of a higher input voltage.

## APPLICATIONS INFORMATION

### Reference

Internal to the LT1120 is a 2.5V trimmed class B output reference. The reference was designed to be able to source or sink current so it could be used in supply splitting applications as well as a general purpose reference for external circuitry. The design of the reference allows it to source typically 4mA or 5mA and sink 2mA. The available source and sink current decreases as temperature increases. It is sometimes desirable to decrease the AC output impedance by placing an output capacitor on them. The reference in the LT1120 becomes unstable with large capacitive loads placed directly on it. When using an output capacitor, about  $20\Omega$  should be used to isolate the capacitor from the reference pin. This  $20\Omega$  resistor can be placed directly in series with the capacitor or alternatively the reference line can have  $20\Omega$  placed in series with it and then a capacitor to ground. This is shown in Figure 1. Other than placing large capacitive loads on the reference, no other precautions are necessary and the reference is stable with nominal stray capacitances.

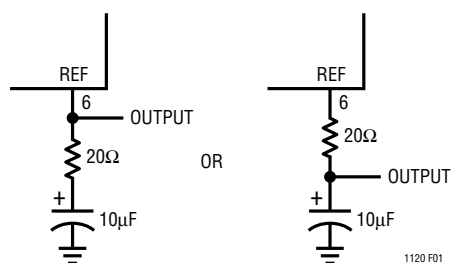

Figure 1. Bypassing Reference

### Overload Protection

The main regulator in the LT1120 is current limited at approximately 250mA. The current limit is stable with both input voltage and temperature.

Like most other IC regulators, a minimum load is required on the output of the LT1120 to maintain regulation. For most standard regulators this is normally specified at 5mA. Of course, for a micropower regulator this would be a tremendously large current. The output must be large enough to absorb all the leakage current of the pass transistor at the maximum operating temperature. It also affects the transient response; low output currents have long recovery times from load transients. At high operating temperatures the minimum load current increases and having too low of a load current may cause the output to go unregulated. Devices are tested for minimum load current at high temperature. The output voltage setting resistors to the feedback terminal can usually be used to provide the minimum load current.

### Frequency Compensation

The LT1120 is frequency compensated by a dominant pole on the output. An output capacitor of  $10\mu\text{F}$  is usually large enough to provide good stability. Increasing the output capacitor above  $10\mu\text{F}$  further improves stability. In order to ensure stability, a feedback capacitor is needed between the output pin and the feedback pin. This is because stray capacitance can form another pole with the large value of feedback resistors used with the LT1120. Also, a feedback capacitor minimizes noise pickup and improves ripple rejection.

With the large dynamic operating range of the output current, 10000:1, frequency response changes widely. Low AC impedance capacitors are needed to insure stability. While solid tantalum are best, aluminum electrolytics can be used but larger capacitor values may be needed.

## TYPICAL APPLICATIONS

### Regulator with Output Voltage Monitor

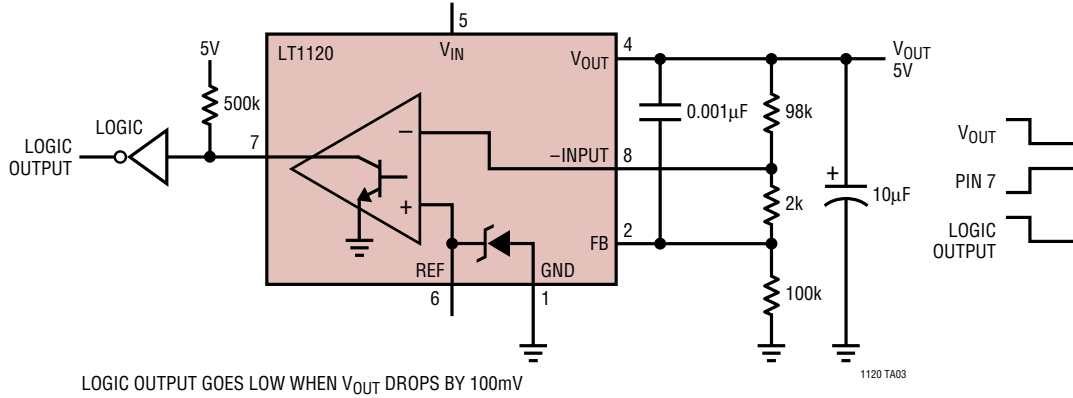

### Compensating the Comparator as an Op Amp

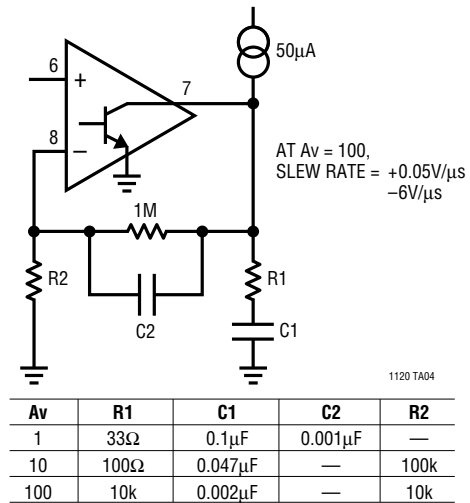

### 1A Low Dropout Regulator

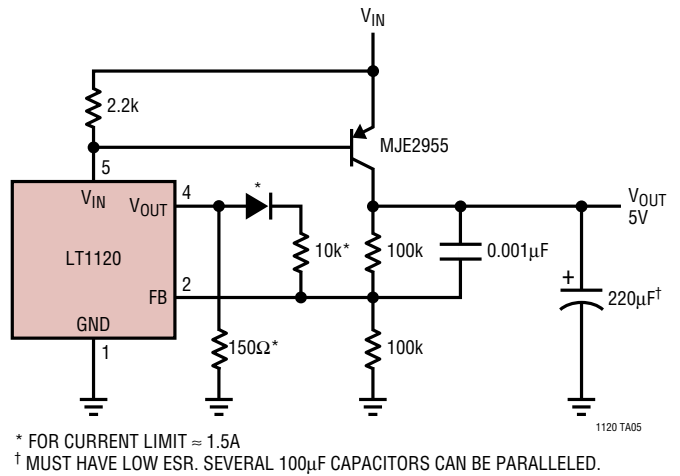

# TYPICAL APPLICATIONS

5V Regulator

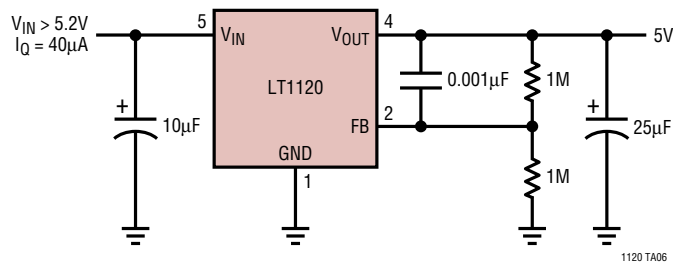

Regulator with Improved Transient Response

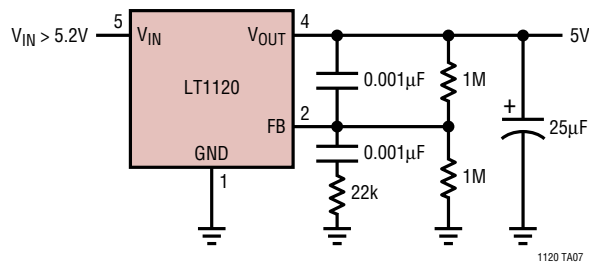

Battery-Backup Regulator

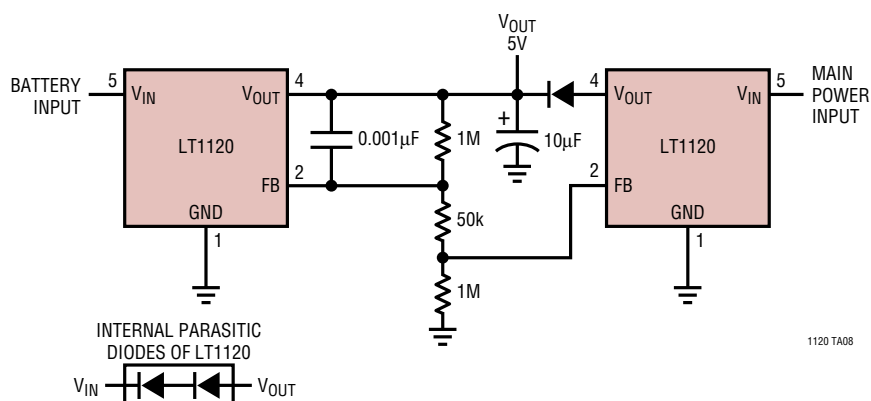

5V Regulator with Feedback Shutdown

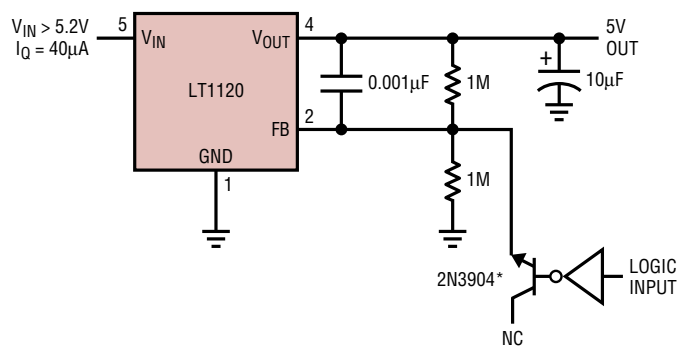

\* TRANSISTOR USED BECAUSE OF LOW LEAKAGE CHARACTERISTICS. TO TURN OFF THE OUTPUT OF THE LT1120 FORCE FB (PIN 2) > 2.5V.

1120 TA09

**SCHEMATIC DIAGRAM**

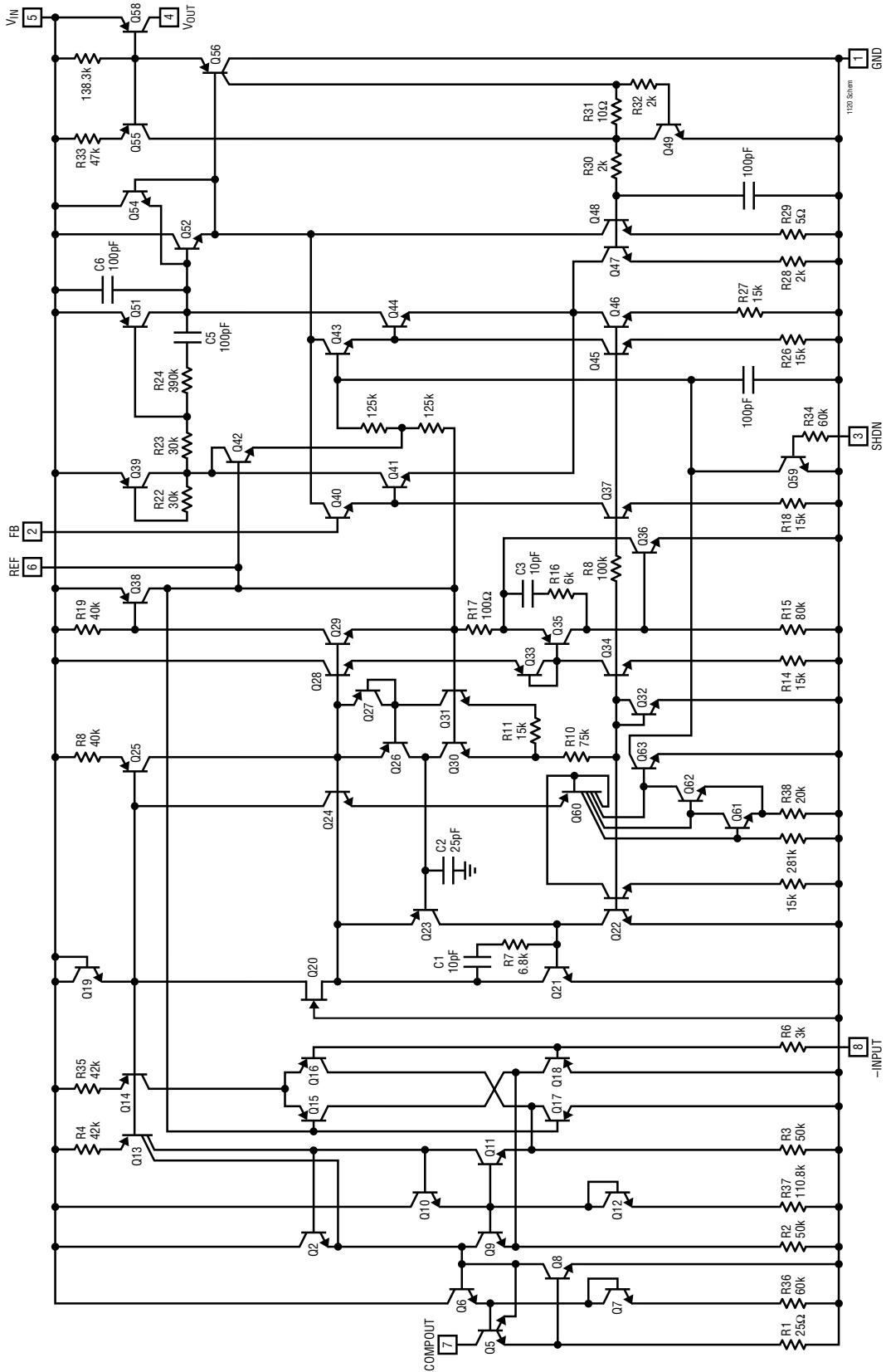

# PACKAGE DESCRIPTION

## H Package 8-Lead TO-5 Metal Can (.230 Inch PCD) (Reference LTC DWG # 05-08-1321)

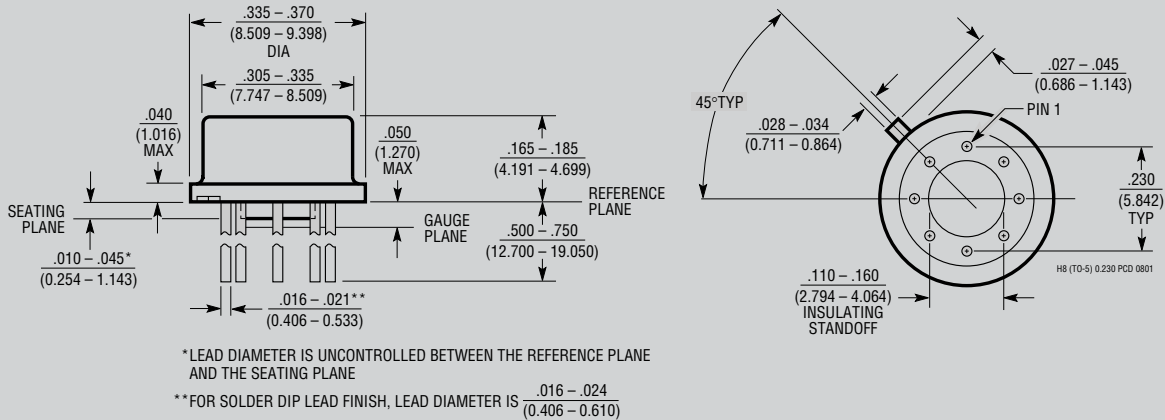

## J8 Package 8-Lead CERDIP (Narrow .300 Inch, Hermetic) (Reference LTC DWG # 05-08-1110)

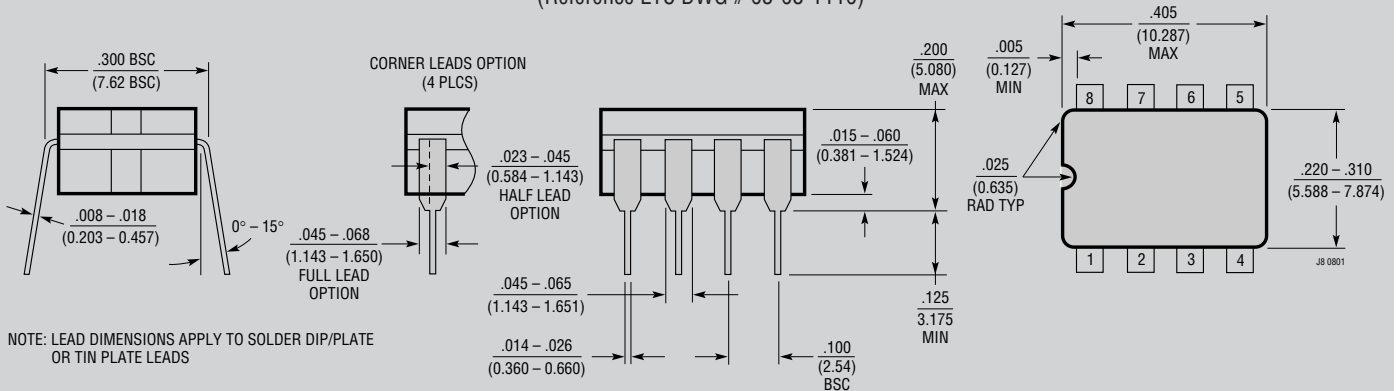

# OBSOLETE PACKAGES

## N8 Package 8-Lead PDIP (Narrow .300 Inch) (Reference LTC DWG # 05-08-1510)

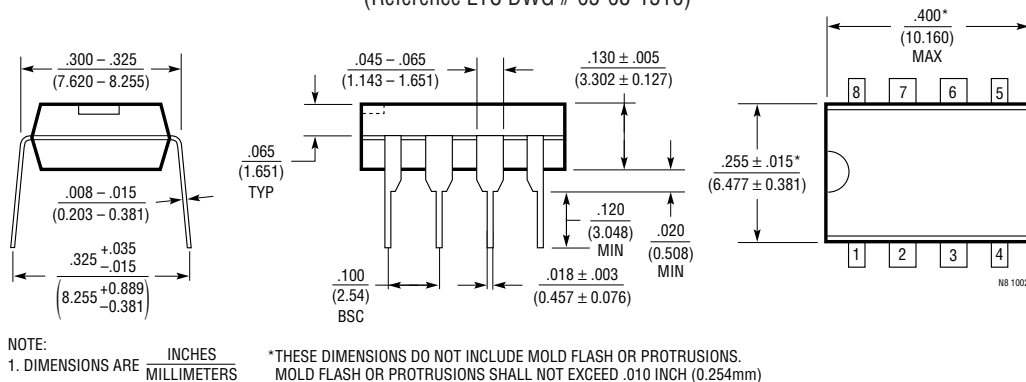

## TYPICAL APPLICATION

### Current Limited 1A Regulator

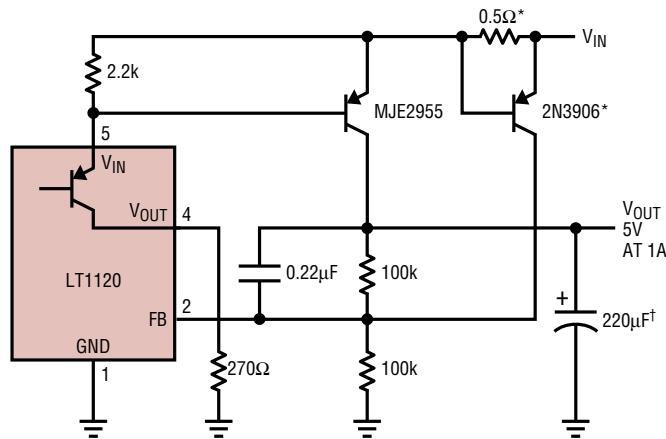

\* SETS CURRENT LIMIT BUT INCREASES DROPOUT VOLTAGE BY 0.5V  
 † MUST HAVE LOW ESR. SEVERAL 100μF CAPACITORS CAN BE PARALLELED

1120 TA10

## PACKAGE DESCRIPTION

**S8 Package**  
**8-Lead Plastic Small Outline (Narrow .150 Inch)**  
 (Reference LTC DWG # 05-08-1610)

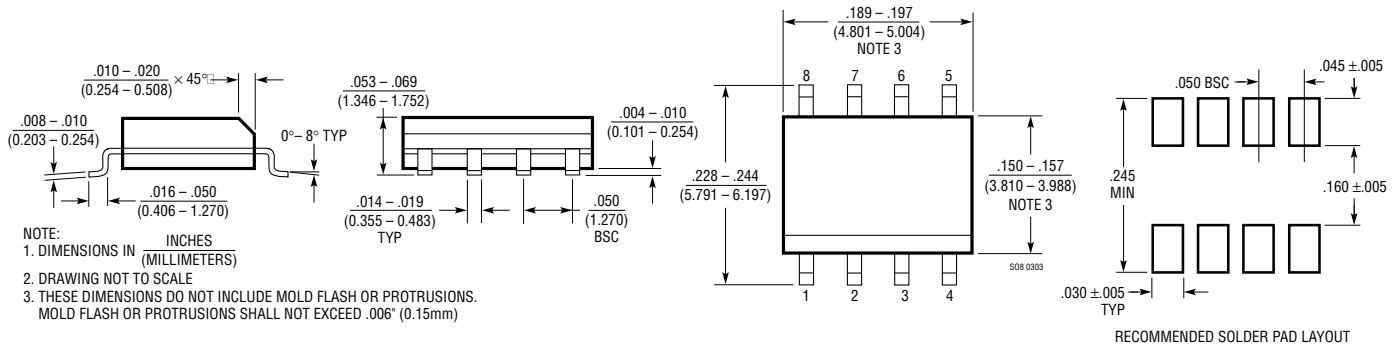

## RELATED PARTS

PART NUMBER	DESCRIPTION	COMMENTS
LT1121	150mA Micropower Low Dropout Regulator	0.4V Dropout Voltage, Includes Shutdown, SOT-223, S8 Packages
LT1521	300mA Micropower Low Dropout Regulator	Lowest I <sub>Q</sub> Low Dropout Regulator, SOT-223, S8, MS8 Packages
LT1761	100mA Micropower Low Noise, Low Dropout Regulator	SOT-23, 20μV <sub>RMS</sub> Noise, 20μA I <sub>Q</sub> , ThinSOT Package

## Looking for pricing, stock, or lifecycle information?

Click below to explore more details on WIN SOURCE:

 [View LT1120CN8#PBF on WIN SOURCE](#)

 [Linear Technology](#) Information

## Optimize Your Supply Chain with WIN SOURCE Solutions

-  Global Sourcing Solution
-  Obsolete Management
-  Cost Control Management
-  Shortage Management
-  Alternative Solution
-  Excess Inventory Management