



**THE DATASHEET OF  
LT1236BIS8-10#PBF**



## FEATURES

- **Ultra-Low Drift: 5ppm/°C Max**
- **Trimmed to High Accuracy: 0.05% Max**
- **Industrial Temperature Range SO Package**
- Operates in Series or Shunt Mode
- Pin Compatible with AD586, AD587
- Output Sinks and Sources in Series Mode
- Very Low Noise < 1ppm p-p (0.1Hz to 10Hz)
- 100% Noise Tested
- > 100dB Ripple Rejection
- Minimum Input/Output Differential of 1V

## APPLICATIONS

- A/D and D/A Converters
- Precision Regulators
- Precision Scales
- Inertial Navigation Systems
- Digital Voltmeters

## DESCRIPTION

The LT<sup>®</sup>1236 is a precision reference that combines ultra-low drift and noise with excellent long-term stability and high output accuracy. The reference output will both source and sink up to 10mA and is almost totally immune to input voltage variations. Two voltages are available: 5V and 10V. The 10V version can be used as a shunt regulator (two-terminal zener) with the same precision characteristics as the three-terminal connection. Special care has been taken to minimize thermal regulation effects and temperature induced hysteresis.

The LT1236 combines both superior accuracy and temperature coefficient specifications without the use of high power, on-chip heaters. The LT1236 references are based on a buried zener diode structure which eliminates noise and stability problems with surface breakdown devices. Further, a subsurface zener exhibits better temperature drift and time stability than even the best band-gap references.

LT, LTC and LT are registered trademarks of Linear Technology Corporation.

## TYPICAL APPLICATION

Basic Positive and Negative Connections

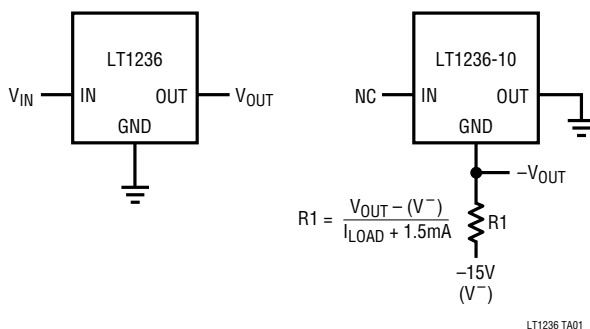

Typical Distribution of Temperature Drift

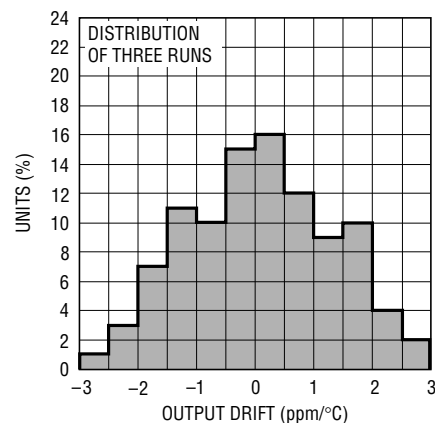

## ABSOLUTE MAXIMUM RATINGS

Input Voltage .....	40V	Output Short-Circuit Duration	
Input/Output Voltage Differential .....	35V	$V_{IN} = 35V$ .....	10 sec
Output-to-Ground Voltage (Shunt Mode Current Limit)		$V_{IN} \leq 20V$ .....	Indefinite
LT1236-5 .....	10V	Operating Temperature Range	
LT1236-10 .....	16V	LT1236AC, BC, CC .....	0°C to 70°C
Trim Pin-to-Ground Voltage		LT1236AI, BI, CI .....	-40°C to 85°C
Positive .....	Equal to $V_{OUT}$	Storage Temperature Range .....	-65°C to 150°C
Negative .....	-20V	Lead Temperature (Soldering, 10 sec) .....	300°C

## PACKAGE/ORDER INFORMATION

 <p>TOP VIEW</p> <p>NC* [1] [8] NC*</p> <p><math>V_{IN}</math> [2] [7] NC*</p> <p>NC* [3] [6] <math>V_{OUT}</math></p> <p>GND [4] [5] TRIM**</p> <p>N8 PACKAGE 8-LEAD PDIP</p> <p>*CONNECTED INTERNALLY. DO NOT CONNECT EXTERNAL CIRCUITRY TO THESE PINS</p> <p>**SEE APPLICATIONS INFORMATION SECTION</p> <p><math>T_{JMAX} = 125^{\circ}C, \theta_{JA} = 130^{\circ}C/W</math></p>	ORDER PART NUMBER	 <p>TOP VIEW</p> <p>NC* [1] [8] NC*</p> <p><math>V_{IN}</math> [2] [7] NC*</p> <p>NC* [3] [6] <math>V_{OUT}</math></p> <p>GND [4] [5] TRIM**</p> <p>S8 PACKAGE 8-LEAD PLASTIC SO</p> <p>*CONNECTED INTERNALLY. DO NOT CONNECT EXTERNAL CIRCUITRY TO THESE PINS</p> <p>**SEE APPLICATIONS INFORMATION SECTION</p> <p><math>T_{JMAX} = 125^{\circ}C, \theta_{JA} = 190^{\circ}C/W</math></p>	ORDER PART NUMBER
			LT1236ACN8-5 LT1236BCN8-5 LT1236CCN8-5 LT1236ACN8-10 LT1236BCN8-10 LT1236CCN8-10 LT1236AIN8-5 LT1236BIN8-5 LT1236CIN8-5 LT1236AIN8-10 LT1236BIN8-10 LT1236CIN8-10
			S8 PART MARKING
			236AC5    236AI5 236BC5    236BI5 236CC5    236CI5 236AC1    236AI1 236BC1    236BI1 236CC1    236CI1

Consult factory for Military grade parts.

## ELECTRICAL CHARACTERISTICS

$V_{IN} = 10V, I_{OUT} = 0, T_A = 25^{\circ}C$ , unless otherwise noted.

PARAMETER	CONDITIONS	LT1236-5			UNITS
		MIN	TYP	MAX	
Output Voltage (Note 1)	LT1236A-5	4.9975	5.000	5.0025	V
	LT1236B-5/LT1236C-5	4.9950	5.000	5.0050	V
Output Voltage Temperature Coefficient (Note 2)	$T_{MIN} \leq T_J \leq T_{MAX}$				
	LT1236A-5		2	5	ppm/°C
	LT1236B-5		5	10	ppm/°C
	LT1236C-5		10	15	ppm/°C
Line Regulation (Note 3)	$7.2V \leq V_{IN} \leq 10V$		4	12	ppm/V
		●		20	ppm/V
	$10V \leq V_{IN} \leq 40V$		2	6	ppm/V
		●		10	ppm/V
Load Regulation (Sourcing Current) (Note 3)	$0 \leq I_{OUT} \leq 10mA$	●	10	20	ppm/mA
		●		35	ppm/mA

**ELECTRICAL CHARACTERISTICS**  $V_{IN} = 10V, I_{OUT} = 0, T_A = 25^{\circ}C$ , unless otherwise noted.

PARAMETER	CONDITIONS	LT1236-5			UNITS
		MIN	TYP	MAX	
Load Regulation (Sinking Current) (Note 3)	$0 \leq I_{OUT} \leq 10mA$	●	60	100 150	ppm/mA ppm/mA
Supply Current		●	0.8	1.2 1.5	mA mA
Output Voltage Noise (Note 5)	$0.1Hz \leq f \leq 10Hz$ $10Hz \leq f \leq 1kHz$		3.0 2.2	3.5	$\mu V_{P-P}$ $\mu V_{RMS}$
Long-Term Stability of Output Voltage (Note 6)	$\Delta t = 1000Hrs$ Non-Cumulative		20		ppm
Temperature Hysteresis of Output (Note 7)	$\Delta T = \pm 25^{\circ}C$		10		ppm

$V_{IN} = 15V, I_{OUT} = 0, T_A = 25^{\circ}C$ , unless otherwise noted.

PARAMETER	CONDITIONS	LT1236-10			UNITS	
		MIN	TYP	MAX		
Output Voltage (Note 1)	LT1236A-10 LT1236B-10/LT1236C-10		9.995 9.990	10.000 10.000	10.005 10.010	V V
Output Voltage Temperature Coefficient (Note 2)	$T_{MIN} \leq T_J \leq T_{MAX}$ LT1236A-10 LT1236B-10 LT1236C-10		2 5 10	5 10 15	ppm/ $^{\circ}C$ ppm/ $^{\circ}C$ ppm/ $^{\circ}C$	
Line Regulation (Note 3)	$11.5V \leq V_{IN} \leq 14.5V$  $14.5V \leq V_{IN} \leq 40V$	● ●	1.0 0.5	4 6 2 4	ppm/V ppm/V ppm/V ppm/V	
Load Regulation (Sourcing Current) (Note 3)	$0 \leq I_{OUT} \leq 10mA$	●	12	25 40	ppm/mA ppm/mA	
Load Regulation (Shunt Mode) (Notes 3, 4)	$1.7mA \leq I_{SHUNT} \leq 10mA$	●	50	100 150	ppm/mA ppm/mA	
Series Mode Supply Current		●	1.2	1.7 2.0	mA mA	
Shunt Mode Minimum Current	$V_{IN}$ is Open	●	1.1	1.5 1.7	mA mA	
Output Voltage Noise (Note 5)	$0.1Hz \leq f \leq 10Hz$ $10Hz \leq f \leq 1kHz$		6.0 3.5	6	$\mu V_{P-P}$ $\mu V_{RMS}$	
Long-Term Stability of Output Voltage (Note 6)	$\Delta t = 1000Hrs$ Non-Cumulative		30		ppm	
Temperature Hysteresis of Output (Note 7)	$\Delta T = \pm 25^{\circ}C$		5		ppm	

The ● denotes specifications which apply over the specified temperature range.

**Note 1:** Output voltage is measured immediately after turn-on. Changes due to chip warm-up are typically less than 0.005%.

**Note 2:** Temperature coefficient is measured by dividing the change in output voltage over the temperature range by the change in temperature. **Incremental slope is also measured at 25°C.**

**Note 3:** Line and load regulation are measured on a pulse basis. Output changes due to die temperature change must be taken into account separately.

**Note 4:** Shunt mode regulation is measured with the input open. With the input connected, shunt mode current can be reduced to 0mA. Load regulation will remain the same.

**Note 5:** RMS noise is measured with a 2-pole highpass filter at 10Hz and a 2-pole lowpass filter at 1kHz. The resulting output is full-wave rectified and then integrated for a fixed period, making the final reading an average as opposed to RMS. Correction factors are used to convert from average to RMS, and 0.88 is used to correct for the non-ideal bandwidth of the filters. Peak-to-peak noise is measured with a single highpass filter at 0.1Hz and a 2-pole lowpass filter at 10Hz. The unit is enclosed in a still-air environment to eliminate thermocouple effects on the leads. Test time is 10 seconds.

**Note 6:** Long-term stability typically has a logarithmic characteristic and therefore, changes after 1000 hours tend to be much smaller than before that time. Total drift in the second thousand hours is normally less than one third that of the first thousand hours, with a continuing trend toward reduced drift with time. Significant improvement in long-term drift can be

## ELECTRICAL CHARACTERISTICS

$V_{IN} = 15V$ ,  $I_{OUT} = 0$ ,  $T_A = 25^\circ C$ , unless otherwise noted.

realized by preconditioning the IC with a 100-200 hour, 125°C burn in. Long term stability will also be affected by differential stresses between the IC and the board material created during board assembly. Temperature cycling and baking of completed boards is often used to reduce these stresses in critical applications.

**Note 7:** Hysteresis in output voltage is created by package stress that differs depending on whether the IC was previously at a higher or lower

temperature. Output voltage is always measured at 25°C, but the IC is cycled to 50°C or 0°C before successive measurements. Hysteresis is roughly proportional to the square of temperature change. Hysteresis is not normally a problem for operational temperature excursions, but can be significant in critical narrow temperature range applications where the instrument might be stored at high or low temperatures.

## TYPICAL PERFORMANCE CHARACTERISTICS

**Ripple Rejection**

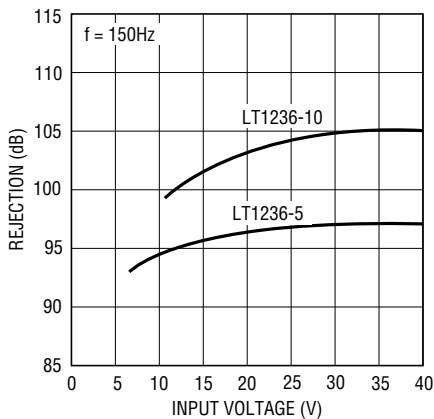

LT1236 G01

**Ripple Rejection**



LT1236 G02

**Minimum Input/Output Differential, LT1236-10**

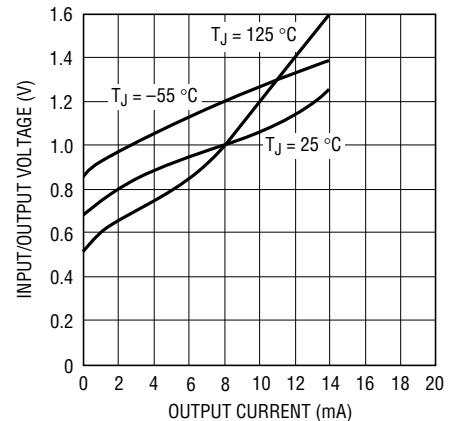

LT1236 G03

**Start-Up (Series Mode)**

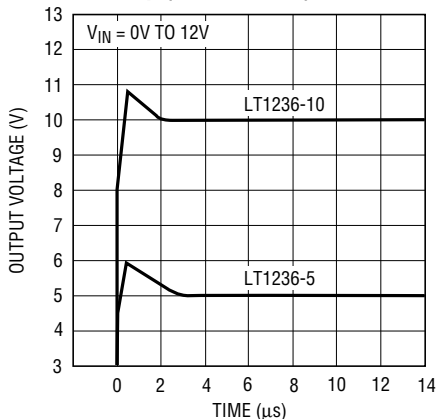

LT1236 G04

**Start-Up (Shunt Mode), LT1236-10**



LT1236 G05

**Output Voltage Noise Spectrum**

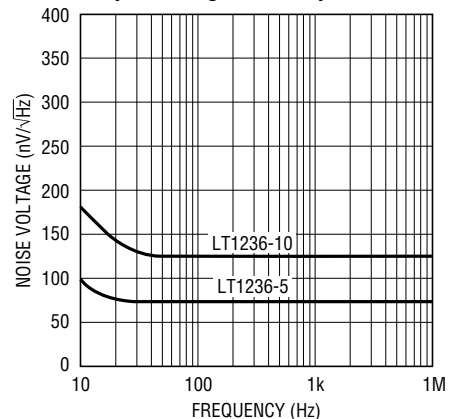

LT1236 G06

# TYPICAL PERFORMANCE CHARACTERISTICS

**Output Voltage Noise**



LT1236 G07

**Output Voltage Temperature Drift  
LT1236-5**



LT1236 G08

**Load Regulation LT1236-5**



LT1236 G09

**Quiescent Current, LT1236-5**

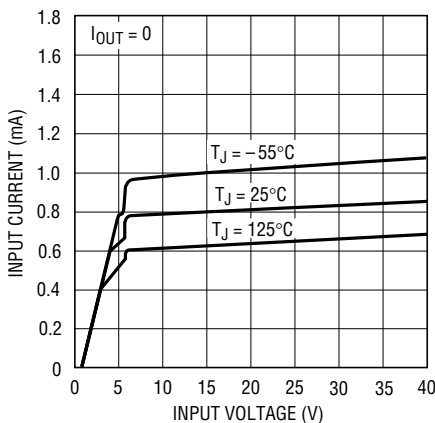

LT1236 G10

**Sink Mode\* Current Limit,  
LT1236-5**

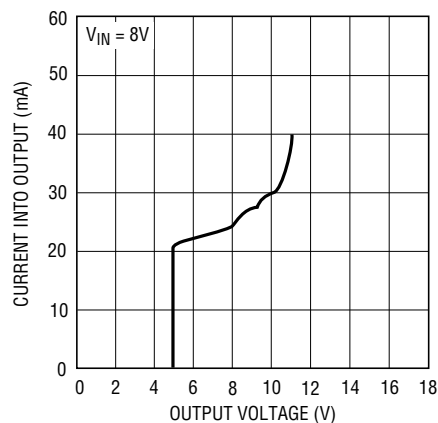

LT1236 G11

\*NOTE THAT AN INPUT VOLTAGE IS REQUIRED FOR 5V UNITS.

**Thermal Regulation, LT1236-5**

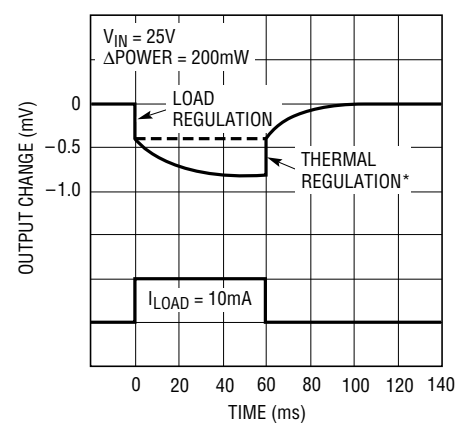

LT1236 G12

\*INDEPENDENT OF TEMPERATURE COEFFICIENT

**Load Transient Response,  
LT1236-5, CLOAD = 0**

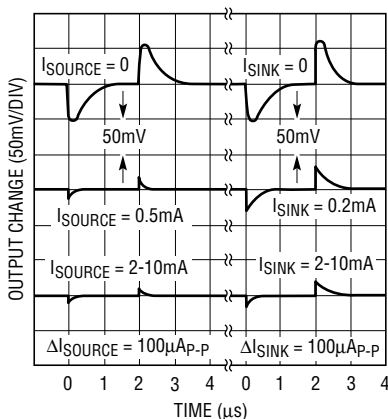

LT1236 G13

**Load Transient Response,  
LT1236-5, CLOAD = 1000pF**

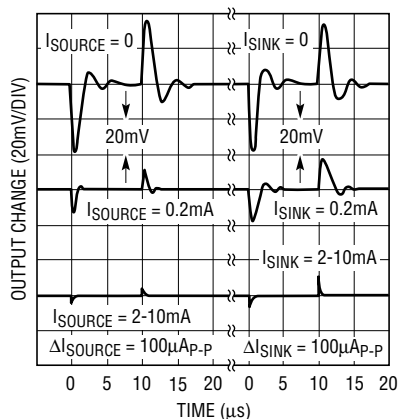

LT1236 G14

**Output Noise 0.1Hz to 10Hz,  
LT1236-5**

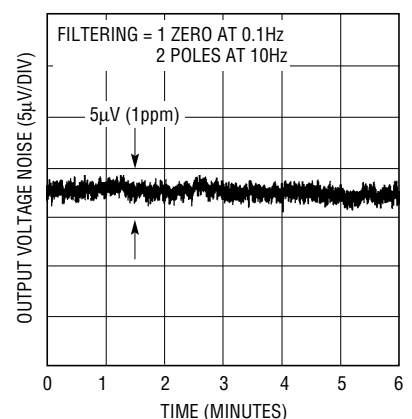

LT1236 G15

## TYPICAL PERFORMANCE CHARACTERISTICS

**Output Voltage Temperature Drift, LT1236-10**



LT1236 G16

**Load Regulation, LT1236-10**



LT1236 G17

**Input Supply Current, LT1236-10**



LT1236 G18

**Shunt Characteristics, LT1236-10**



LT1236 G19

**Shunt Mode Current Limit, LT1236-10**



LT1236 G20

**Thermal Regulation, LT1236-10**



\*INDEPENDENT OF TEMPERATURE COEFFICIENT  
LT1236 G21

**Load Transient Response, LT1236-10, C\_LOAD = 0**

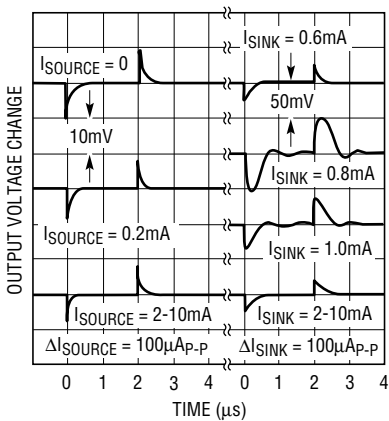

NOTE VERTICAL SCALE CHANGE BETWEEN SOURCING AND SINKING

LT1236 G22

**Load Transient Response, LT1236-10, C\_LOAD = 1000pF**

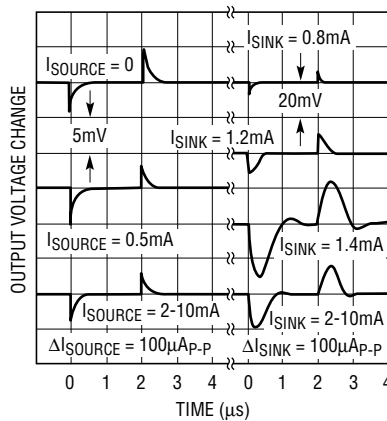

NOTE VERTICAL SCALE CHANGE BETWEEN SOURCING AND SINKING

LT1236 G23

**Output Noise 0.1Hz to 10Hz, LT1236-10**

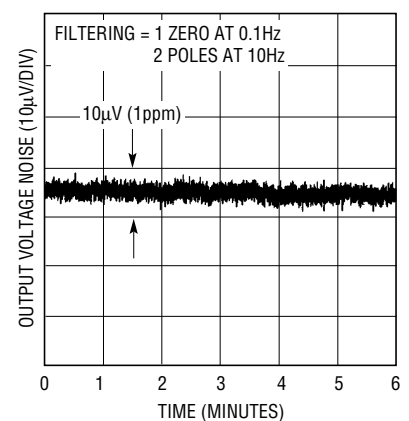

LT1236 G24

## APPLICATIONS INFORMATION

### Effect of Reference Drift on System Accuracy

A large portion of the temperature drift error budget in many systems is the system reference voltage. This graph indicates the maximum temperature coefficient allowable if the reference is to contribute no more than 0.5LSB error to the overall system performance. The example shown is a 12-bit system designed to operate over a temperature range from 25°C to 65°C. Assuming the system calibration is performed at 25°C, the temperature span is 40°C. It can be seen from the graph that the temperature coefficient of the reference must be no worse than 3ppm/°C if it is to contribute less than 0.5LSB error. For this reason, the LT1236 family has been optimized for low drift.

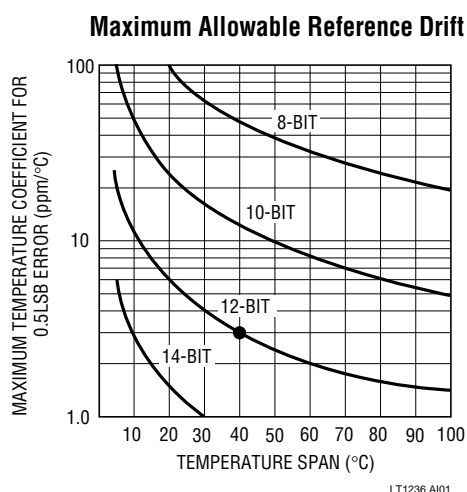

### Trimming Output Voltage

The LT1236-10 has a trim pin for adjusting output voltage. The impedance of the trim pin is about 12kΩ with a nominal open circuit voltage of 5V. It is designed to be driven from a source impedance of 3kΩ or less to minimize changes in the LT1236 TC with output trimming. Attenuation between the trim pin and the output is 70:1. This allows ±70mV trim range when the trim pin is tied to the wiper of a potentiometer connected between the output and ground. A 10kΩ potentiometer is recommended, preferably a 20 turn cermet type with stable characteristics over time and temperature.

The LT1236-10 “A” version is pre-trimmed to ±5mV and therefore can utilize a restricted trim range. A 75k resistor

in series with a 20kΩ potentiometer will give ±10mV trim range. Effect on the output TC will be only 1ppm/°C for the ±5mV trim needed to set the “A” device to 10.000V.

### LT1236-5

The LT1236-5 does have an output voltage trim pin, but the TC of the nominal 4V open circuit voltage at pin 5 is about -1.7mV/°C. For the voltage trimming not to affect reference output TC, the external trim voltage must track the voltage on the trim pin. Input impedance of the trim pin is about 100kΩ and attenuation to the output is 13:1. The technique shown below is suggested for trimming the output of the LT1236-5 while maintaining minimum shift in output temperature coefficient. The R1/R2 ratio is chosen to minimize interaction of trimming and TC shifts, so the exact values shown should be used.

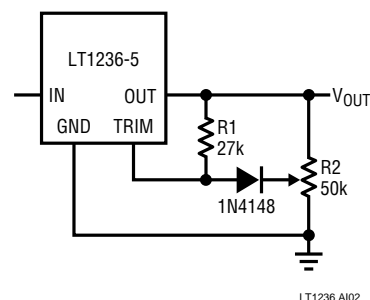

### Capacitive Loading and Transient Response

The LT1236 is stable with all capacitive loads, but for optimum settling with load transients, output capacitance should be under 1000pF. The output stage of the reference is class AB with a fairly low idling current. This makes transient response worse-case at light load currents. Because of internal current drain on the output, actual worst-case occurs at  $I_{LOAD} = 0$  on LT1236-5 and  $I_{LOAD} = 1.4\text{mA}$  (sinking) on LT1236-10. Significantly better load transient response is obtained by moving slightly away from these points. See Load Transient Response curves for details. In general, best transient response is obtained when the output is sourcing current. In critical applications, a 10μF solid tantalum capacitor with several ohms in series provides optimum output bypass.

## APPLICATIONS INFORMATION

### Kelvin Connections

Although the LT1236 does not have true force/sense capability at its outputs, significant improvements in ground loop and line loss problems can be achieved with proper hook-up. In series mode operation, the ground pin of the LT1236 carries only  $\approx 1\text{mA}$  and can be used as a sense line, greatly reducing ground loop and loss problems on the low side of the reference. The high side supplies load current so line resistance must be kept low. Twelve feet of #22 gauge hook-up wire or 1 foot of 0.025 inch printed circuit trace will create 2mV loss at 10mA output current. This is equivalent to 1LSB in a 10V, 12-bit system.

The following circuits show proper hook-up to minimize errors due to ground loops and line losses. Losses in the output lead can be greatly reduced by adding a PNP boost transistor if load currents are 5mA or higher. R2 can be added to further reduce current in the output sense lead.

### Effects of Air Movement on Low Frequency Noise

The LT1236 has very low noise because of the buried zener used in its design. In the 0.1Hz to 10Hz band, peak-to-peak noise is about 0.5ppm of the DC output. To achieve this low noise, however, care must be taken to shield the reference from ambient air turbulence. Air movement can create noise because of thermoelectric differences between IC package leads and printed circuit board materials and/or sockets. Power dissipation in the reference, even though it rarely exceeds 20mW, is enough to cause small

temperature gradients in the package leads. Variations in thermal resistance, caused by uneven air flow, create differential lead temperatures, thereby causing thermoelectric voltage noise at the output of the reference.

#### Standard Series Mode



#### Series Mode with Boost Transistor

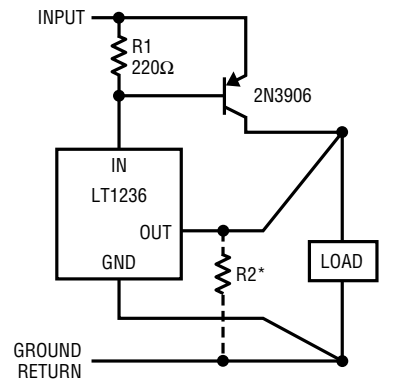

\*OPTIONAL—REDUCES CURRENT IN OUTPUT SENSE LEAD: R2 = 2.4k (LT1236-5), 5.6k (LT1236-10)

LT1236 AI04

## TYPICAL APPLICATIONS

### Restricted Trim Range for Improved Resolution, 10V, "A" Version Only

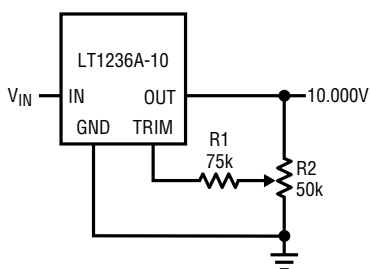

TRIM RANGE  $\approx \pm 10\text{mV}$

LT1236 TA10

### LT1236-10 Full Trim Range ( $\pm 0.7\%$ )

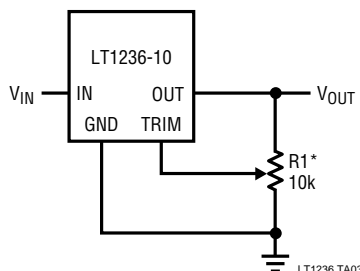

\*CAN BE RAISED TO 20k FOR LESS CRITICAL APPLICATIONS

LT1236 TA03

### Negative Series Reference

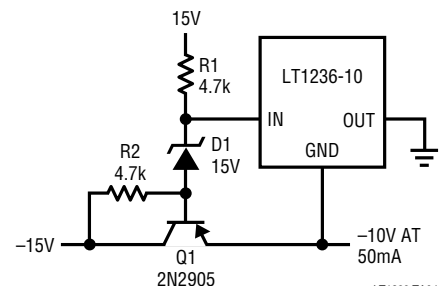

LT1236 TA04

# TYPICAL APPLICATIONS

**Boosted Output Current with No Current Limit**

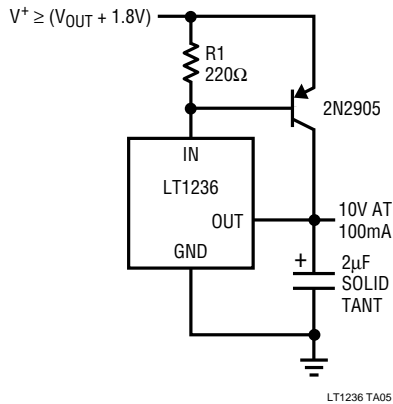

LT1236 TA05

**Boosted Output Current with Current Limit**

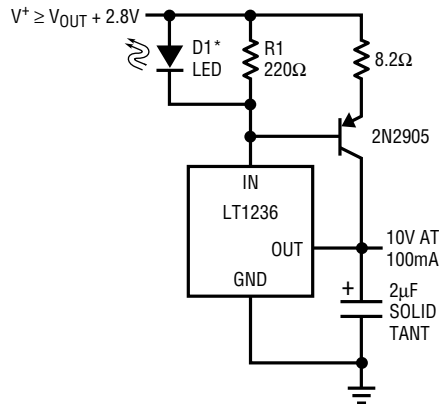

\*GLOWS IN CURRENT LIMIT, DO NOT OMIT

LT1236 TA06

**±10V Output Reference**

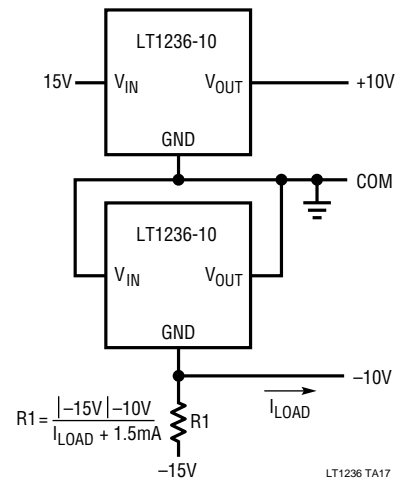

LT1236 TA17

**Handling Higher Load Currents**

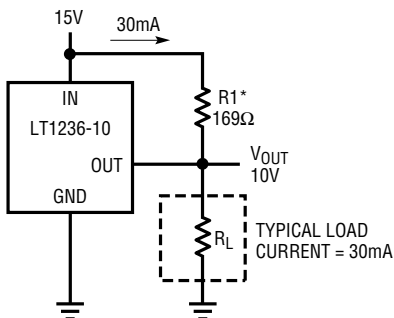

\*SELECT R1 TO DELIVER TYPICAL LOAD CURRENT. LT1236 WILL THEN SOURCE OR SINK AS NECESSARY TO MAINTAIN PROPER OUTPUT. DO NOT REMOVE LOAD AS OUTPUT WILL BE DRIVEN UNREGULATED HIGH. LINE REGULATION IS DEGRADED IN THIS APPLICATION

LT1236 TA07

**Operating 5V Reference from 5V Supply**

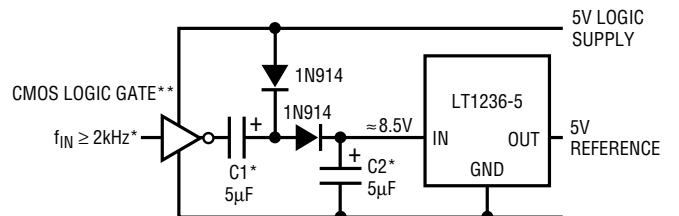

\*FOR HIGHER FREQUENCIES C1 AND C2 MAY BE DECREASED  
\*\*PARALLEL GATES FOR HIGHER REFERENCE CURRENT LOADING

LT1236 TA15

**CMOS DAC with Low Drift Full-Scale Trimming\*\***

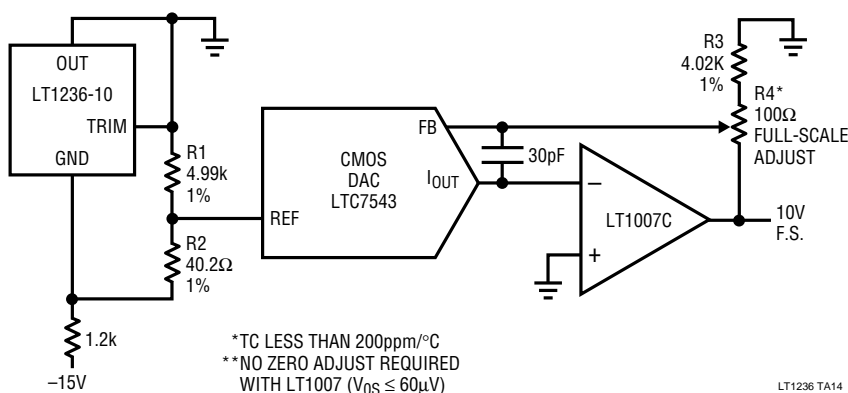

\*TC LESS THAN 200ppm/°C  
\*\*NO ZERO ADJUST REQUIRED WITH LT1007 (V<sub>OS</sub> ≤ 60μV)

LT1236 TA14

**Trimming 10V Units to 10.24V**

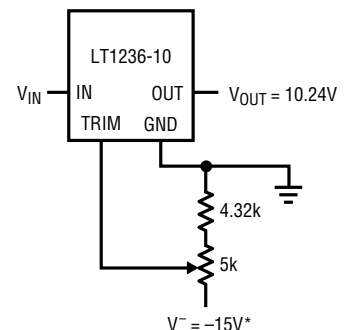

\*MUST BE WELL REGULATED  
 $\frac{dV_{OUT}}{dV^-} = \frac{15mV}{V}$

LT1236 TA11

TYPICAL APPLICATIONS

Strain Gauge Conditioner for 350Ω Bridge



\*THIS RESISTOR PROVIDES POSITIVE FEEDBACK TO THE BRIDGE TO ELIMINATE LOADING EFFECT OF THE AMPLIFIER. EFFECTIVE  $Z_{IN}$  OF AMPLIFIER STAGE IS  $\geq 1M\Omega$ . IF R2 TO R5 ARE CHANGED, SET R6 = R3

\*\*BRIDGE IS ULTRA-LINEAR WHEN ALL LEGS ARE ACTIVE, TWO IN COMPRESSION AND TWO IN TENSION, OR WHEN ONE SIDE IS ACTIVE WITH ONE COMPRESSED AND ONE TENSIONED LEG  
 †OFFSET AND DRIFT OF LM301A ARE VIRTUALLY ELIMINATED BY DIFFERENTIAL CONNECTION OF LT1012C

LT1236 TA08

Negative Shunt Reference Driven by Current Source

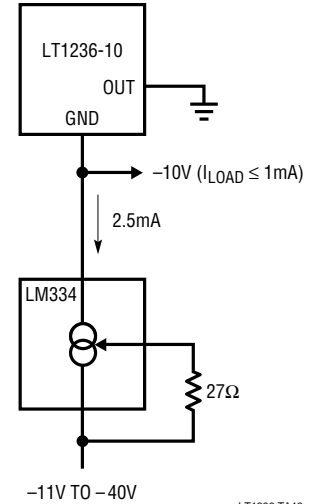

LT1236 TA13

Precision DAC Reference with System TC Trim



\*TRIMS 1mA REFERENCE CURRENT TC BY  $\pm 40ppm/^\circ C$ . THIS TRIM SCHEME HAS VERY LITTLE EFFECT ON ROOM TEMPERATURE CURRENT TO MINIMIZE ITERATIVE TRIMMING

LT1236 TA16

2-Pole Lowpass Filtered Reference

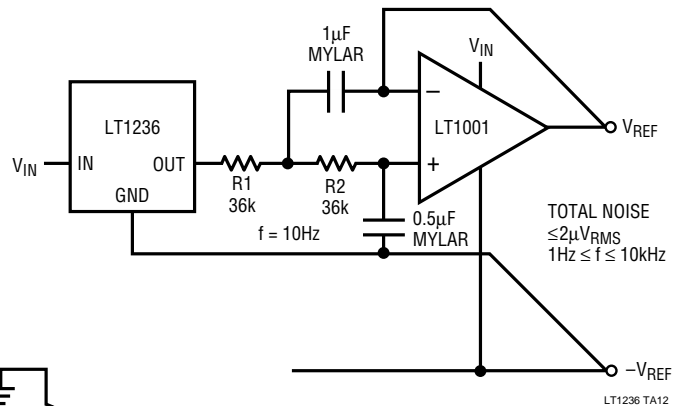

LT1236 TA12

# TYPICAL APPLICATIONS

Ultra-Linear Platinum Temperature Sensor\*

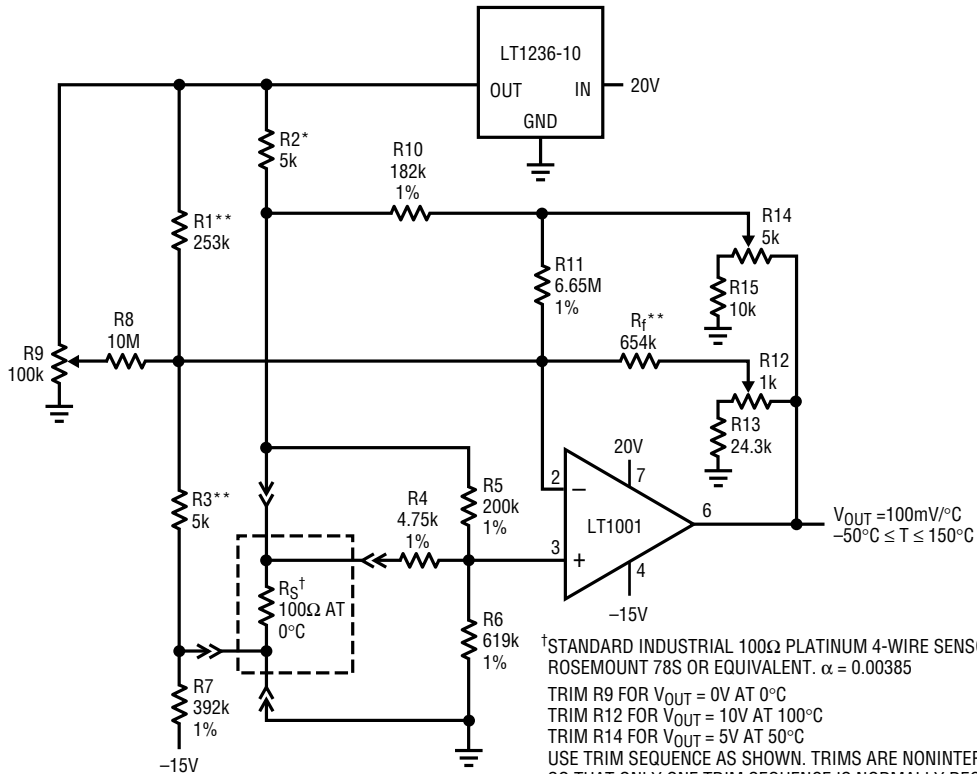

†STANDARD INDUSTRIAL 100Ω PLATINUM 4-WIRE SENSOR, ROSEMOUNT 78S OR EQUIVALENT.  $\alpha = 0.00385$   
 TRIM R9 FOR  $V_{OUT} = 0V$  AT  $0^{\circ}C$   
 TRIM R12 FOR  $V_{OUT} = 10V$  AT  $100^{\circ}C$   
 TRIM R14 FOR  $V_{OUT} = 5V$  AT  $50^{\circ}C$   
 USE TRIM SEQUENCE AS SHOWN. TRIMS ARE NONINTERACTIVE SO THAT ONLY ONE TRIM SEQUENCE IS NORMALLY REQUIRED.  
 \*FEEDBACK LINEARIZES OUTPUT TO  $\pm 0.005^{\circ}C$  FROM  $-50^{\circ}C$  TO  $150^{\circ}C$   
 \*\*WIREWOUND RESISTORS WITH LOW TC

LT1236 TA09

# EQUIVALENT SCHEMATIC



LT1236 ES

**PACKAGE DESCRIPTION** Dimensions in inches (millimeters) unless otherwise noted.

**N8 Package  
8-Lead Plastic DIP**

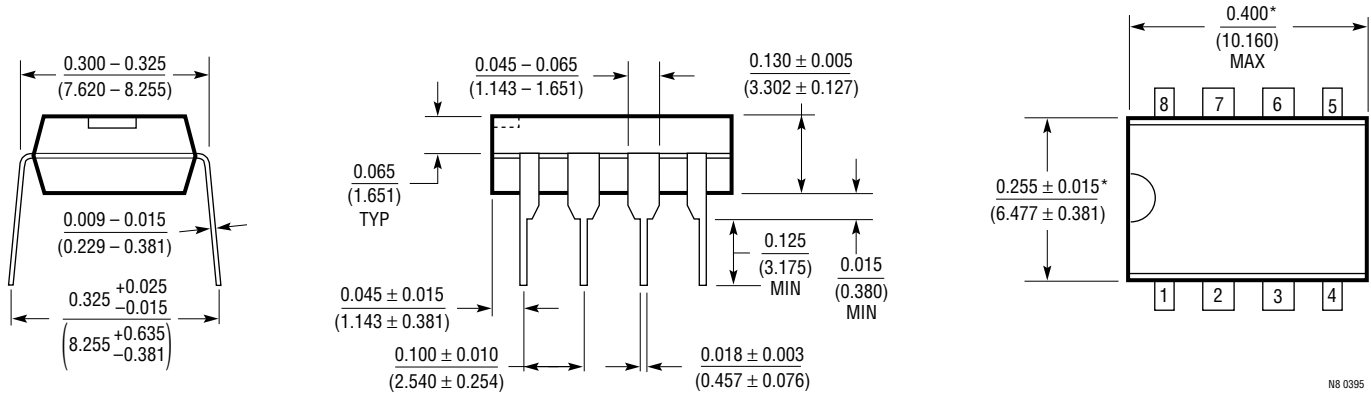

\*THESE DIMENSIONS DO NOT INCLUDE MOLD FLASH OR PROTRUSIONS.  
MOLD FLASH OR PROTRUSIONS SHALL NOT EXCEED 0.010 INCH (0.254mm).

**S8 Package  
8-Lead Plastic SOIC**

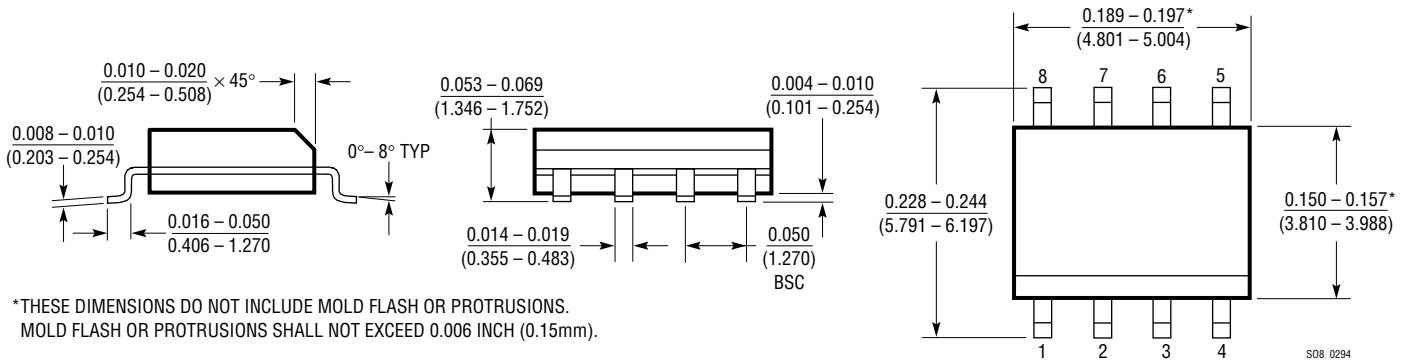

\*THESE DIMENSIONS DO NOT INCLUDE MOLD FLASH OR PROTRUSIONS.  
MOLD FLASH OR PROTRUSIONS SHALL NOT EXCEED 0.006 INCH (0.15mm).

**RELATED PARTS**

PART NUMBER	DESCRIPTION	COMMENTS
LT1019	Precision Bandgap Reference	0.05%, 5ppm/°C
LT1027	Precision 5V Reference	0.02%, 2ppm/°C

## Looking for pricing, stock, or lifecycle information?

Click below to explore more details on WIN SOURCE:

 [View LT1236BIS8-10#PBF on WIN SOURCE](#)

 [Linear Technology](#) Information

## Optimize Your Supply Chain with WIN SOURCE Solutions

-  Global Sourcing Solution
-  Obsolete Management
-  Cost Control Management
-  Shortage Management
-  Alternative Solution
-  Excess Inventory Management