



**THE DATASHEET OF
LT1769CFE#PBF**



Constant-Current/ Constant-Voltage 2A Battery Charger with Input Current Limiting

FEATURES

- Simple Solution to Charge NiCd, NiMH and Lithium Rechargeable Batteries—Charging Current Programmed by Resistors or DAC
- Adapter Current Limit Allows Maximum Possible Charging Current During System Use*
- Precision 0.5% Accuracy for Voltage Mode Charging
- Available in 20-Lead Exposed Pad TSSOP and 28-Lead Narrow SSOP Packages
- High Efficiency Current Mode PWM with 3A Internal Switch
- 5% Charge Current Accuracy
- Adjustable Undervoltage Lockout
- Automatic Shutdown When AC Adapter is Removed
- Low Reverse Battery Drain Current: 3 μ A
- Current Sensing Can Be at Either Terminal of the Battery
- Charging Current Soft Start
- Shutdown Control

APPLICATIONS

- Chargers for NiCd, NiMH, Lead-Acid, Lithium Rechargeable Batteries
- Switching Regulators with Precision Current Limit

LT, LTC and LT are registered trademarks of Linear Technology Corporation.

*US patent number 5,723,970

**See LT1510 for 1.5A charger; see LT1511 for 3A charger

DESCRIPTION

The LT[®]1769 current mode PWM battery charger is a simple, efficient solution to fast charge modern rechargeable batteries including lithium-ion (Li-Ion), nickel-metal-hydride (NiMH) and nickel-cadmium (NiCd) that require constant-current and/or constant-voltage charging. The internal switch is capable of delivering 2A** DC current (3A peak current). Charge current can be programmed by resistors or a DAC to within 5%. With 0.5% reference voltage accuracy, the LT1769 meets the critical constant-voltage charging requirement for Li-Ion cells.

A third control loop is provided to regulate the current drawn from the input AC adapter. This allows simultaneous operation of the equipment and battery charging without overloading the adapter. Charge current is reduced to keep the adapter current below specified levels.

The LT1769 can charge batteries ranging from 1V to 20V. Ground sensing of current is not required and the battery's negative terminal can be tied directly to ground. A saturating switch running at 200kHz gives high charging efficiency and small inductor size. A blocking diode is not required between the chip and the battery because the chip goes into sleep mode and drains only 3 μ A when the wall adapter is unplugged.

TYPICAL APPLICATION

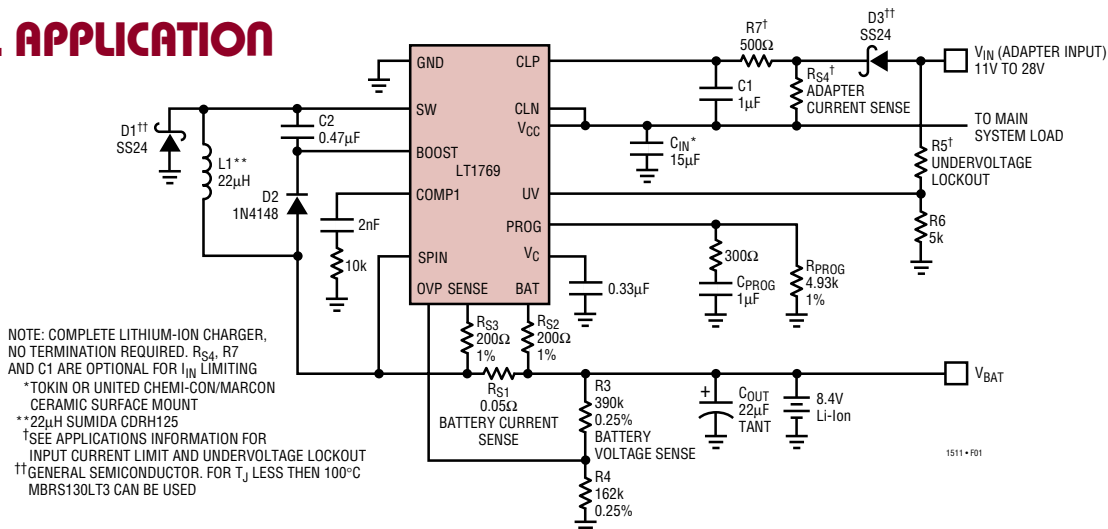

Figure 1. 2A Lithium-Ion Battery Charger

ABSOLUTE MAXIMUM RATINGS (Note 1)

Supply Voltage

(V _{CC} , CLP and CLN Pin Voltage)	30V
BOOST Pin Voltage with Respect to V _{CC}	25V
I _{BAT} (Average)	2A
Operating Junction Temperature Range	
Commercial	0°C to 125°C
Industrial	-40°C to 125°C

Operating Ambient Temperature

Commercial	0°C to 70°C
Industrial	-40°C to 85°C
Storage Temperature Range	-65°C to 150°C
Lead Temperature (Soldering, 10 sec)	300°C

PACKAGE/ORDER INFORMATION

<p>TOP VIEW</p> <p>GN PACKAGE 28-LEAD PLASTIC SSOP T_{JMAX} = 125°C, θ_{JA} = 35°C/W**</p>	<p>ORDER PART NUMBER</p> <p>LT1769CGN LT1769IGN</p> <p>* ALL V_{CC} PINS SHOULD BE CONNECTED TOGETHER CLOSE TO THE PINS ** ALL GND PINS ARE FUSED TO INTERNAL DIE ATTACH PADDLE FOR HEAT SINKING. CONNECT THESE PINS TO EXPANDED PC LANDS FOR PROPER HEAT SINKING. 35°C/W THERMAL RESISTANCE ASSUMES AN INTERNAL GROUND PLANE DOUBLING AS A HEAT SPREADER</p>	<p>TOP VIEW</p> <p>FE PACKAGE 20-LEAD PLASTIC TSSOP T_{JMAX} = 125°C, θ_{JA} = 35°C/W† EXPOSED PAD IS GROUND (MUST BE SOLDERED TO PCB) EXPOSED PAD SIZE: $\frac{3.0}{(.188)} \times \frac{4.1}{(.162)}$</p>	<p>ORDER PART NUMBER</p> <p>LT1769CFE LT1769IFE</p> <p>† THE BOTTOM METAL PLATE OF THIS PACKAGE IS FUSED TO INTERNAL GROUND AND IS FOR HEAT SINKING. SOLDER THE BOTTOM METAL PLATE ONTO PCB GROUND PLANE FOR HEAT SINKING.</p>
--	---	--	--

Consult LTC Marketing for parts specified with wider operating temperature ranges.

ELECTRICAL CHARACTERISTICS

The ● denotes specifications which apply over the full operating temperature range, otherwise specifications are at T_A = 25°C. V_{CC} = 16V, V_{BAT} = 8V, R_{S2} = R_{S3} = 200Ω (see Block Diagram), V_{CLN} = V_{CC}. No load on any outputs unless otherwise noted.

PARAMETER	CONDITIONS	MIN	TYP	MAX	UNITS	
Overall						
Supply Current	V _{PROG} = 2.7V, V _{CC} ≤ 20V	●	4.5	6.8	mA	
	V _{PROG} = 2.7V, 20V < V _{CC} ≤ 25V	●	4.6	7.0	mA	
Sense Amplifier CA1 Gain and Input Offset Voltage (With R _{S2} = 200Ω, R _{S3} = 200Ω) (Measured across R _{S1})(Note 2)	8V ≤ V _{CC} ≤ 25V, 0V ≤ V _{BAT} ≤ 20V					
	R _{PROG} = 4.93k	●	93	100	107	mV
	R _{PROG} = 49.3k	●	8	10	12	mV
	T _A < 0°C		7		13	mV
	V _{CC} = 28V, V _{BAT} = 20V					
	R _{PROG} = 4.93k	●	90		110	mV
R _{PROG} = 49.3k	●	7		13	mV	
T _A < 0°C		6		14	mV	

ELECTRICAL CHARACTERISTICS The ● denotes specifications which apply over the full operating temperature range, otherwise specifications are at $T_A = 25^\circ\text{C}$. $V_{CC} = 16\text{V}$, $V_{BAT} = 8\text{V}$, $R_{S2} = R_{S3} = 200\Omega$ (see Block Diagram), $V_{CLN} = V_{CC}$. No load on any outputs unless otherwise noted.

PARAMETER	CONDITIONS		MIN	TYP	MAX	UNITS
Overall						
V_{CC} Undervoltage Lockout (Switch OFF) Threshold	Measured at UV Pin	●	6	7	8	V
UV Pin Input Current	$0.2\text{V} \leq V_{UV} \leq 8\text{V}$	●		0.1	5	μA
UV Output Voltage at UV_{OUT} Pin	In Undervoltage State, $I_{UVOUT} = 70\mu\text{A}$	●		0.1	0.5	V
UV Output Leakage Current at UV_{OUT} Pin	$8\text{V} \leq V_{UV}$, $V_{UVOUT} = 5\text{V}$	●		0.1	3	μA
Reverse Current from Battery (When V_{CC} Is Not Connected, V_{SW} Is Floating)	$V_{BAT} \leq 20\text{V}$, $V_{UV} \leq 0.4\text{V}$			3	15	μA
Boost Pin Current	$V_{CC} = 20\text{V}$, $V_{BOOST} = 0\text{V}$ $V_{CC} = 28\text{V}$, $V_{BOOST} = 0\text{V}$ $2\text{V} \leq V_{BOOST} - V_{CC} < 8\text{V}$ (Switch ON) $8\text{V} \leq V_{BOOST} - V_{CC} \leq 25\text{V}$ (Switch ON)			0.1 0.25 6 8	10 20 9 12	μA μA mA mA
Switch						
Switch ON Resistance	$8\text{V} \leq V_{CC} \leq V_{MAX}$, $I_{SW} = 2\text{A}$, $V_{BOOST} - V_{SW} \geq 2\text{V}$	●		0.15	0.25	Ω
$\Delta I_{BOOST}/\Delta I_{SW}$ During Switch ON	$V_{BOOST} = 24\text{V}$, $I_{SW} \leq 2\text{A}$			25	35	mA/A
Switch OFF Leakage Current	$V_{SW} = 0\text{V}$, $V_{CC} \leq 20\text{V}$ $20\text{V} < V_{CC} \leq 28\text{V}$	● ●		2 4	100 200	μA μA
Minimum I_{PROG} for Switch ON			2	4	20	μA
Minimum I_{PROG} for Switch OFF		●	1	2.4		mA
Maximum V_{BAT} for Switch ON		●			$V_{CC} - 2$	V
Current Sense Amplifier CA1 Inputs (Sense, BAT)						
Input Bias Current		●		-50	-125	μA
Input Common Mode Low		●	-0.25			V
Input Common Mode High		●			$V_{CC} - 2$	V
SPIN Input Current				-100	-200	μA
Reference						
Reference Voltage (Note 3)	$R_{PROG} = 4.93\text{k}$, Measured at OVP with VA Supplying I_{PROG} and Switch OFF		2.448	2.465	2.477	V
Reference Voltage	All Conditions of V_{CC} , $T_A \geq 0^\circ\text{C}$ $T_A < 0^\circ\text{C}$ (Note 4)	● ●	2.441 2.43		2.489 2.489	V V
Oscillator						
Switching Frequency			180	200	220	kHz
Switching Frequency	All Conditions of V_{CC} , $T_A \geq 0^\circ\text{C}$ $T_A < 0^\circ\text{C}$	● ●	170 160	200	230 230	kHz kHz
Maximum Duty Cycle		●	90 85	93		% %
Current Amplifier CA2						
Transconductance	$V_C = 1\text{V}$, $I_{VC} = \pm 1\mu\text{A}$		150	250	550	μmho
Maximum V_C for Switch OFF		●			0.6	V
I_{VC} Current (Out of Pin)	$V_C \geq 0.6\text{V}$ $V_C < 0.45\text{V}$				100 3	μA mA

ELECTRICAL CHARACTERISTICS The ● denotes specifications which apply over the full operating temperature range, otherwise specifications are at $T_A = 25^\circ\text{C}$. $V_{CC} = 16\text{V}$, $V_{BAT} = 8\text{V}$. No load on any outputs unless otherwise noted.

PARAMETER	CONDITIONS	MIN	TYP	MAX	UNITS
Voltage Amplifier VA					
Transconductance (Note 3)	Output Current from 50 μA to 500 μA	0.25	0.6	1.3	mho
Output Source Current	$V_{OVP} = V_{REF} + 10\text{mV}$, $V_{PROG} = V_{REF} + 10\text{mV}$	1.1			mA
OVP Input Bias Current	VA Output Current at 0.5mA	●	±3	±10	nA
	VA Output Current at 0.5mA, $T_A > 90^\circ\text{C}$	●	-15	25	nA
	VA Output Current at 0.5mA, $T_A < 0^\circ\text{C}$			±15	nA
Current Limit Amplifier CL1, $8\text{V} \leq \text{Input Common Mode}$					
Turn-On Threshold	0.5mA Output Current	93	100	110	mV
Transconductance	Output Current from 50 μA to 500 μA	0.5	1	2	mho
CLP Input Current	0.5mA Output Current, $V_{UV} \geq 0.4\text{V}$		0.3	1	μA
CLN Input Current	0.5mA Output Current $V_{UV} \geq 0.4\text{V}$		0.8	2	mA

Note 1: Absolute Maximum Ratings are those values beyond which the life of a device may be impaired.

Note 2: Tested with Test Circuit 1.

Note 3: Tested with Test Circuit 2.

Note 4: A linear interpolation can be used for reference voltage specification between 0°C and -40°C .

TYPICAL PERFORMANCE CHARACTERISTICS

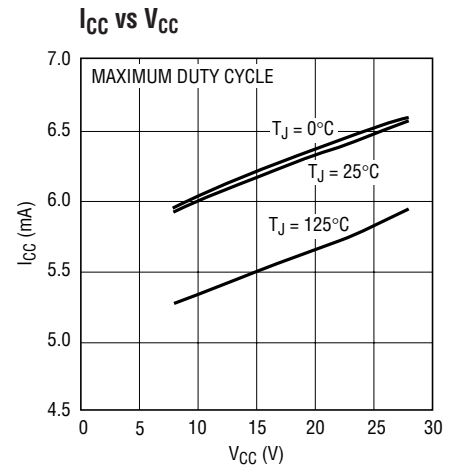
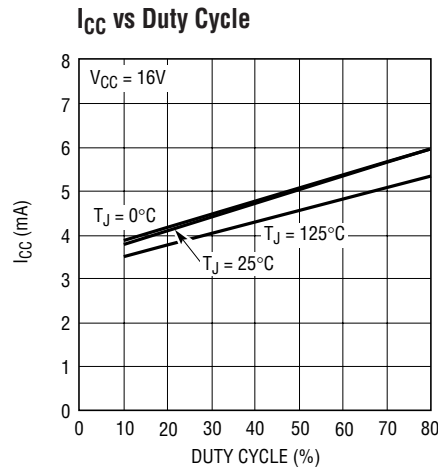
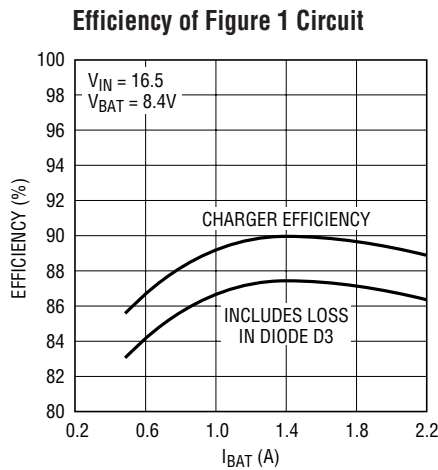

TYPICAL PERFORMANCE CHARACTERISTICS

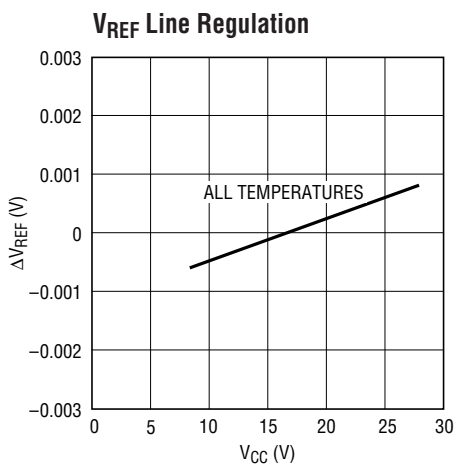

1769 G04

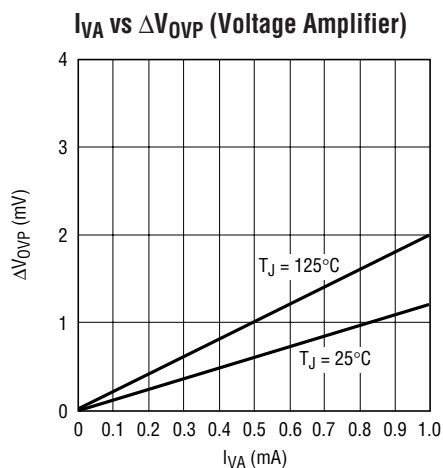

1769 G05

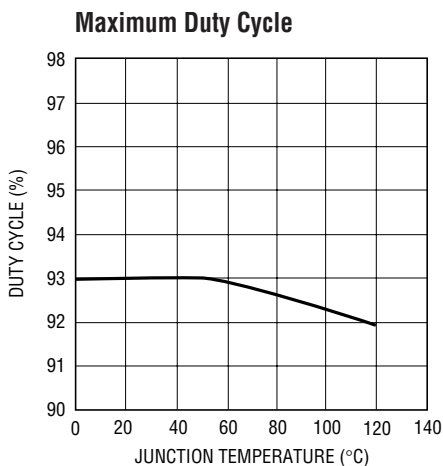

1769 G06

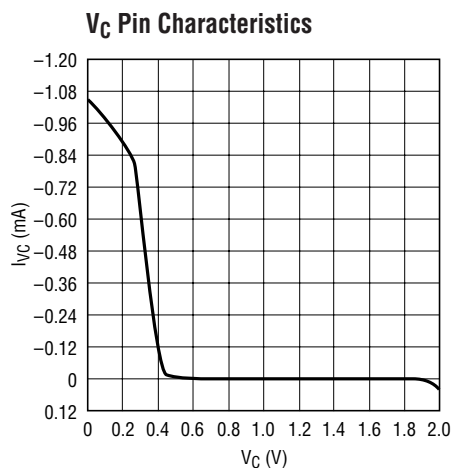

1769 G07

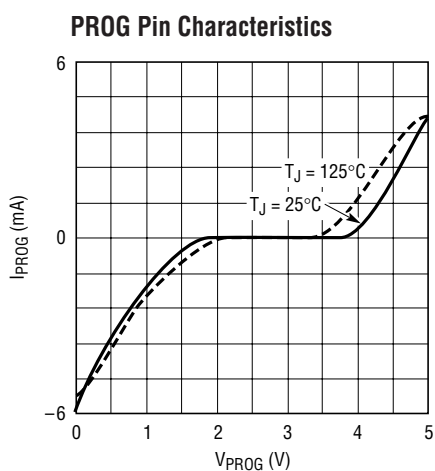

1769 G08

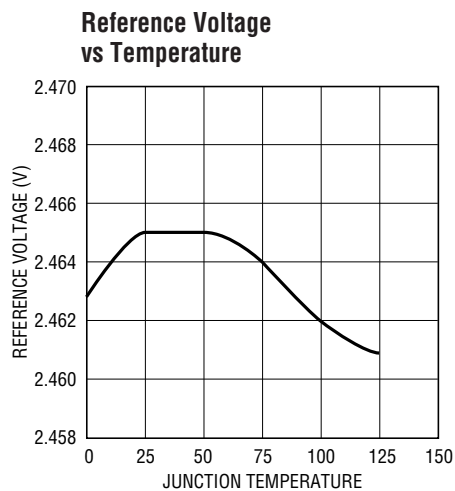

1769 G09

PIN FUNCTIONS (GN/FE Pin Numbers)

GND (Pins 1 to 3, 7, 8, 14, 15, 22, 26 to 28/Pins 4, 5, 14, 20): Ground Pins. Must be connected to expanded PC lands for proper heat sinking. See Applications Information section for details.

SW (Pin 4/Pin 1): Switch Output. The Schottky catch diode must be placed with very short lead length in close proximity to SW pin and GND.

BOOST (Pin 5/Pin 2): This pin is used to bootstrap and drive the switch power NPN transistor to a low on-voltage for low power dissipation. In Figure 1, $V_{BOOST} = V_{CC} + V_{BAT}$ when switch is on. For lowest IC power dissipation, connect boost diode D1 to a 3V to 6V at 30mA voltage source (see Figure 10).

UV (Pin 6/Pin 3): Undervoltage Lockout Input. The rising threshold is at 6.7V with a hysteresis of 0.5V. Switching stops in undervoltage lockout. When the input supply (normally the wall adapter output) to the IC is removed, the UV pin must be pulled down to below 0.7V (a 5k resistor from adapter output to GND is required) otherwise the reverse battery current drained by the IC will be approximately 200 μ A instead of 3 μ A. Do not leave the UV pin floating. When connected to V_{IN} with no resistor divider, the built-in 6.7V undervoltage lockout will be effective.

OVP (Pin 9/Pin 6): This is the input to amplifier VA with a threshold of 2.465V. Typical bias current is about 3nA out of this pin. For charging lithium-ion batteries, VA monitors the battery voltage and reduces charging when battery voltage reaches the preset value. If it is not used, the OVP pin should be grounded.

CLP (Pin 10/Pin 8): This is the positive input to the input current limit amplifier CL1. The threshold is set at 100mV. When used to limit supply current, a filter is needed to filter out the 200kHz switching noise.

CLN (Pin 11/Pin 7): This is the negative input to the input current limit amplifier CL1.

COMP1 (Pin 12/Pin 9): This is the compensation node for the input current limit amplifier CL1. At input adapter current limit, this node rises to 1V. By forcing COMP1 low with an external transistor, amplifier CL1 will be defeated (no adapter current limit). COMP1 can source 200 μ A. If

this function is not used, the resistor and capacitor on COMP1 pin, shown on the Figure 1 circuit, are not needed.

SENSE (Pin 13/Pin 10): Current Amplifier CA1 Input. Sensing can be at either terminal of the battery.

SPIN (Pin 16/Pin 11): This pin is for the current amplifier CA1 bias. It must be connected to R_{S1} as shown in the 2A Lithium Battery Charger (Figure 1).

BAT (Pin 17/Pin 12): Current Amplifier CA1 Input.

COMP2 (Pin 18): This is also a compensation node for amplifier CL1. Voltage on this pin rises to 2.8V at input adapter current limit and/or at constant-voltage charging.

UV_{OUT} (Pin 19/Pin 13): This is an open-collector output for undervoltage lockout status. It stays low in undervoltage state. With an external pull-up resistor, it goes high at valid V_{CC} . Note that the base drive of the open-collector NPN comes from CLN pin. UV_{OUT} stays low only when CLN is higher than 2V. Pull-up current should be kept under 100 μ A.

V_C (Pin 20/Pin 15): This is the inner loop control signal for the current mode PWM. Switching starts at 0.7V. In normal operation, a higher V_C corresponds to higher charge current. A capacitor of at least 0.33 μ F to GND filters out noise and controls the rate of soft start. To stop switching, pull this pin low. Typical output current is 30 μ A.

PROG (Pin 21/Pin 16): This pin is for programming the charge current and for system loop compensation. During normal operation, V_{PROG} stays close to 2.465V. If it is shorted to GND switching will stop. When a microprocessor controlled DAC is used to program charge current, it must be capable of sinking current at a compliance up to 2.465V.

V_{CC1}, V_{CC2}, V_{CC3} (Pins 23 to 25/Pins 17 to 19): Input Supply. For good bypass, a low ESR capacitor of 15 μ F or higher is required, with the lead length kept to a minimum. V_{CC} should be between 8V and 28V and at least 3V higher than V_{BAT} . Undervoltage lockout starts and switching stops when V_{CC} goes below 7V typical. Note that there is an internal parasitic diode from SW pin to V_{CC} pin. Do not force V_{CC} below SW by more than 0.7V with battery present. All three V_{CC} pins should be shorted together close to the pins.

BLOCK DIAGRAM

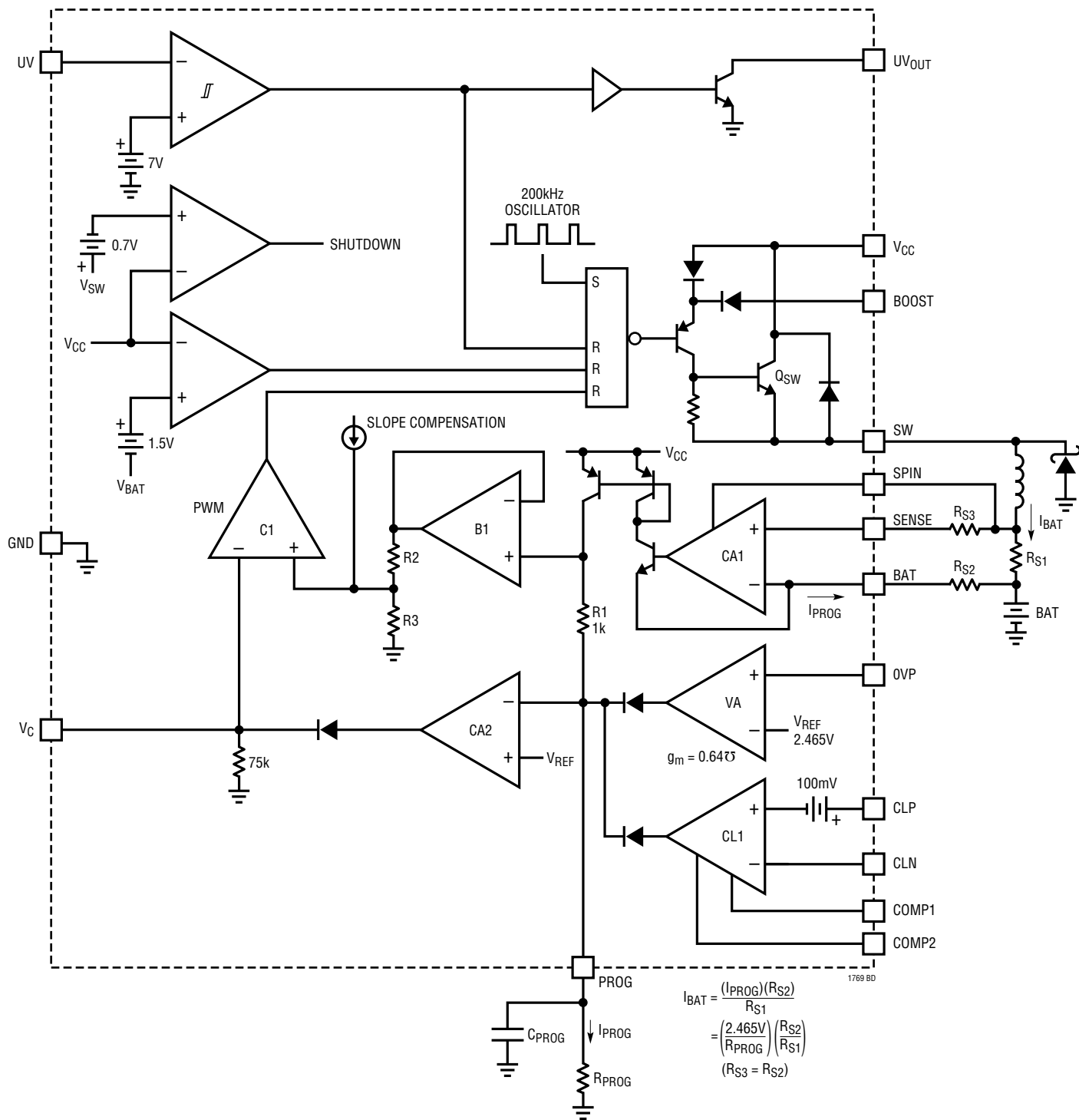

TEST CIRCUITS

Test Circuit 1

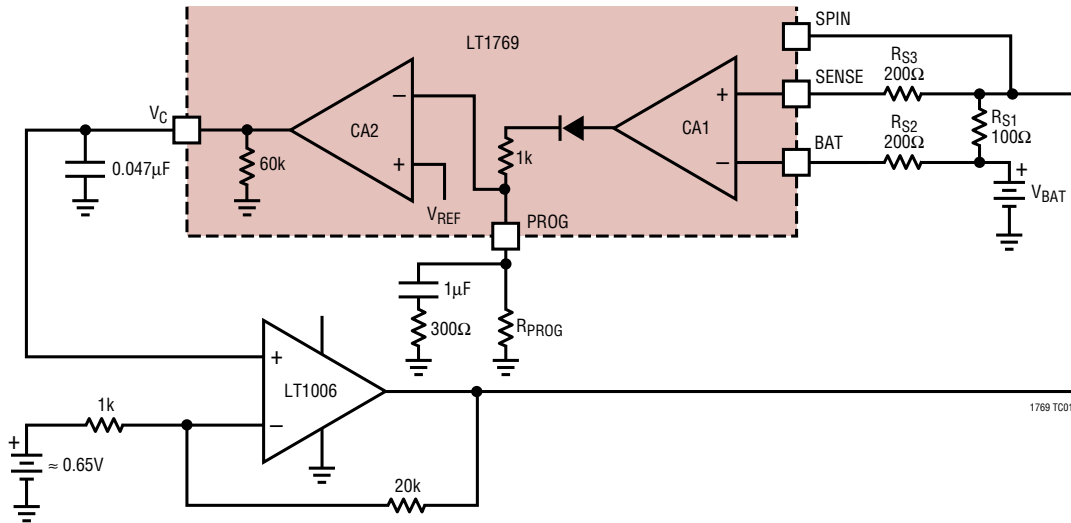

Test Circuit 2

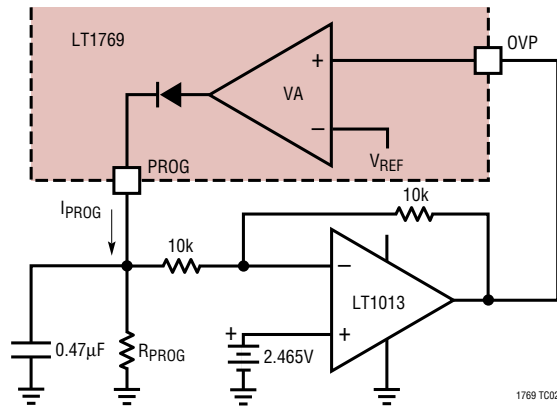

OPERATION

The LT1769 is a current mode PWM step-down (buck) switcher. The battery DC charge current is programmed by a resistor R_{PROG} (or a DAC output current) at the PROG pin (see Block Diagram). Amplifier CA1 converts the charge current through R_{S1} to a much lower current I_{PROG} fed into the PROG pin. Amplifier CA2 compares the output of CA1 with the programmed current and drives the PWM control loop to force them to be equal. High DC accuracy is achieved with averaging capacitor C_{PROG} . Note that I_{PROG} has both AC and DC components. I_{PROG} goes through R1 and generates a ramp signal that is fed to the PWM control comparator C1 through buffer B1 and level

shift resistors R2 and R3, forming the current mode inner loop. The BOOST pin drives the switch NPN Q_{SW} into saturation and reduces power loss. For batteries like lithium-ion that require both constant-current and constant-voltage charging, the 0.5%, 2.465V reference and the amplifier VA reduce the charge current when battery voltage reaches the preset level. For NiMH and NiCd, VA can be used for overvoltage protection. When the input voltage is removed, the V_{CC} pin drops to 0.7V below the battery voltage, forcing the charger into a low battery drain ($3\mu A$ typical) sleep mode. To shut down the charger, simply pull the V_C pin low with a transistor.

APPLICATIONS INFORMATION

Input and Output Capacitors

In the 2A Lithium-Ion Battery Charger (Figure 1), the input capacitor (C_{IN}) is assumed to absorb all input switching ripple current in the converter, so it must have adequate ripple current rating. Worst-case RMS ripple current will be equal to one half of the output charge current. Actual capacitance value is not critical. Solid tantalum capacitors such as the AVX TPS and Sprague 593D series have high ripple current rating in a relatively small surface mount package, but *caution must be used when tantalum capacitors are used for input bypass*. High input surge currents are possible when the adapter is hot-plugged to the charger and solid tantalum capacitors have a known failure mechanism when subjected to very high turn-on surge currents. Selecting a high voltage rating on the capacitor will minimize problems. Consult with the manufacturer before use. Alternatives include new high capacity ceramic ($5\mu\text{F}$ to $20\mu\text{F}$) from Tokin or United Chemi-Con/Marcon, et al. Sanyo OS-CON can also be used.

The output capacitor (C_{OUT}) is also assumed to absorb output switching ripple current. The general formula for capacitor ripple current is:

$$I_{RMS} = \frac{0.29 (V_{BAT}) \left(1 - \frac{V_{BAT}}{V_{CC}}\right)}{(L1)(f)}$$

For example, $V_{CC} = 16\text{V}$, $V_{BAT} = 8.4\text{V}$, $L1 = 20\mu\text{H}$, and $f = 200\text{kHz}$, $I_{RMS} = 0.3\text{A}$.

EMI considerations usually make it desirable to minimize ripple current in the battery leads. Beads or inductors can be added to increase battery impedance at the 200kHz switching frequency. Switching ripple current splits between the battery and the output capacitor depending on the ESR of the output capacitor and the battery impedance. If the ESR of C_{OUT} is 0.2Ω and the battery impedance is raised to 4Ω with a bead or inductor, only 5% of the ripple current will flow into the battery.

Soft-Start and Undervoltage Lockout

The LT1769 is soft-started by the $0.33\mu\text{F}$ capacitor on the V_C pin. On start-up, the V_C pin voltage will quickly rise to 0.5V , then ramp at a rate set by the internal $45\mu\text{A}$ pull-up current and the external capacitor. Charge current starts

ramping up when V_C pin voltage reaches 0.7V and full current is achieved with V_C at 1.1V . With a $0.33\mu\text{F}$ capacitor, the time to reach full charge current is about 10ms and it is assumed that input voltage to the charger will reach full value in less than 10ms . The capacitor can be increased up to $1\mu\text{F}$ if longer input start-up times are needed.

In any switching regulator, conventional time-based soft-starting can be defeated if the input voltage rises much slower than the time out period. This happens because the switching regulators in the battery charger and the computer power supply are typically supplying a fixed amount of power to the load. If the input voltage comes up slowly compared to the soft-start time, the regulators will try to deliver full power to the load when the input voltage is still well below its final value. If the adapter is current limited, it cannot deliver full power at reduced output voltages and the possibility exists for a quasi “latch” state where the adapter output stays in a current limited state at reduced output voltage. For instance, if maximum charger plus computer load power is 25W , a 15V adapter might be current limited at 2A . If adapter voltage is less than ($25\text{W}/2\text{A} = 12.5\text{V}$) when full power is drawn, the adapter voltage will be pulled down by the constant 25W load until it reaches a lower stable state where the switching regulators can no longer supply full load. This situation can be prevented by utilizing *undervoltage lockout*, set higher than the minimum adapter voltage where full power can be achieved.

A fixed undervoltage lockout of 7V is built into the LT1769. This 7V threshold can be increased by adding a resistive divider to the UV pin as shown in Figure 2. Internal lockout is performed by clamping the V_C pin low. The V_C pin is released from its clamped state when the UV pin rises above 7V and is pulled low when the UV pin drops below 6.5V (0.5V hysteresis). At the same time UV_{OUT} goes high with an external pull-up resistor. This signal can be used to alert the system that charging is about to start. The charger will start delivering current about 4ms after V_C is released, as set by the $0.33\mu\text{F}$ capacitor. A resistor divider is used to set the desired V_{CC} lockout voltage as shown in Figure 2. A typical value for $R6$ is 5k and $R5$ is found from:

$$R5 = \frac{R6(V_{IN} - V_{UV})}{V_{UV}}$$

APPLICATIONS INFORMATION

V_{UV} = Rising lockout threshold on the UV pin

V_{IN} = Charger input voltage that will sustain full load power

Example: With $R_6 = 5k$, $V_{UV} = 6.7V$ and setting V_{IN} at 12V;

$$R_5 = 5k (12V - 6.7V)/6.7V = 4k$$

The resistor divider should be connected directly to the adapter output as shown, not to the V_{CC} pin, to prevent battery drain with no adapter voltage. If the UV pin is not used, connect it to the adapter output (not V_{CC}) and connect a resistor no greater than 5k to ground. Floating this pin will cause reverse battery current to increase from $3\mu A$ to $200\mu A$.

If connecting the unused UV pin to the adapter output is not possible, it can be grounded. Although it would seem that grounding the pin creates a permanent lockout state, the UV circuitry is arranged for phase reversal with low voltages on the UV pin to allow the grounding technique to work.

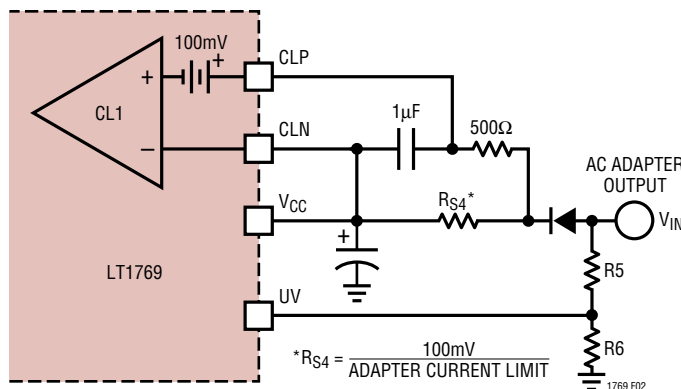

Figure 2. Adapter Input Current Limiting

Adapter Current Limiting

An important feature of the LT1769 is the ability to automatically adjust charge current to a level which avoids overloading the wall adapter. This allows the product to operate at the same time the batteries are being charged without complex load management algorithms. Additionally, batteries will automatically be charged at the maximum possible rate of which the adapter is capable.

This is accomplished by sensing total adapter output current and adjusting the charge current downward if a preset adapter current limit is exceeded. True analog control is used, with closed-loop feedback ensuring that

adapter load current remains below the limit. Amplifier CL1 in Figure 2 senses the voltage across R_{S4} , connected between the CLP and CLN pins. When this voltage exceeds 100mV, the amplifier will override the programmed charge current to limit adapter current to $100mV/R_{S4}$. A lowpass filter formed by 500Ω and $1\mu F$ is required to eliminate switching noise. If the input current limit is not used, both CLP and CLN pins should be connected to V_{CC} .

Charge Current Programming

The basic formula for charge current is (see Block Diagram):

$$I_{BAT} = I_{PROG} \left(\frac{R_{S2}}{R_{S1}} \right) = \left(\frac{2.465V}{R_{PROG}} \right) \left(\frac{R_{S2}}{R_{S1}} \right)$$

where R_{PROG} is the total resistance from PROG pin to ground.

For the sense amplifier CA1 biasing purpose, R_{S3} should have the same value as R_{S2} and SPIN should be connected directly to the sense resistor (R_{S1}) as shown in the Block Diagram.

For example, 2A charge current is needed. For low power dissipation on R_{S1} and enough signal to drive the amplifier CA1, let $R_{S1} = 100mV/2A = 0.05\Omega$. This limits R_{S1} power to 0.2W. Let $R_{PROG} = 5k$, then:

$$\begin{aligned} R_{S2} = R_{S3} &= \frac{(I_{BAT})(R_{PROG})(R_{S1})}{2.465V} \\ &= \frac{(2A)(5k)(0.05)}{2.465V} = 200\Omega \end{aligned}$$

Charge current can also be programmed by pulse width modulating I_{PROG} with a switch Q1 to R_{PROG} at a frequency higher than a few kHz (Figure 3). Charge current will be proportional to the duty cycle of the switch with full current at 100% duty cycle.

Lithium-Ion Charging

The 2A Lithium-Ion Battery Charger (Figure 1) charges at a constant 2A until battery voltage reaches a limit set by R_3 and R_4 . The charger will then automatically go into a constant-voltage mode with current decreasing to near zero over time as the battery reaches full charge. This is the normal regimen for lithium-ion charging, with the charger

APPLICATIONS INFORMATION

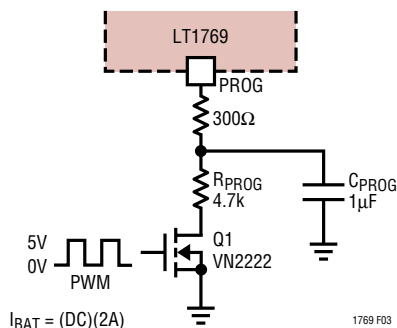

Figure 3. PWM Current Programming

holding the battery at “float” voltage indefinitely. In this case no external sensing of full charge is needed.

Battery Voltage Sense Resistors Selection

To minimize battery drain when the charger is off, current through the R3/R4 divider is set at 15μA. The input current to the OVP pin is 3nA and the error can be neglected.

With divider current set at 15μA, $V_{BAT} = 8.4V$, $R4 = 2.465/15\mu A = 162k$ and,

$$R3 = \frac{(R4)(V_{BAT} - 2.465)}{2.465} = \frac{162k(8.4 - 2.465)}{2.465} = 390k$$

Li-Ion batteries typically require float voltage accuracy of 1%. Accuracy of the LT1769 OVP voltage is ±0.5% at 25°C and ±1% over full temperature. This leads to the possibility that very accurate (0.1%) resistors might be needed for R3 and R4. Actually, the temperature of the LT1769 will rarely exceed 50°C in float mode because charging currents have tapered off to a low level, so 0.25% resistors will normally provide the required level of overall accuracy.

When power is on, there is about 200μA of current flowing out of the BAT and SENSE pins. If the battery is removed during charging, and total load including R3 and R4 is less than 200μA, V_{BAT} could float up to V_{CC} even though the loop has turned switching off. To keep V_{BAT} regulated to the battery voltage in this condition, R3 and R4 can be chosen to draw 0.5mA and Q3 can be added to disconnect them when power is off (Figure 4). R5 isolates the OVP pin from any high frequency noise on V_{IN} . An alternative method

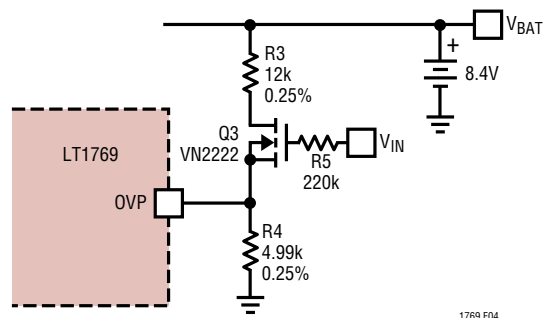

Figure 4. Disconnecting Voltage Divider

is to use a Zener diode with a breakdown voltage two or three volts higher than battery voltage to clamp the V_{BAT} voltage.

Battery manufacturers recommend terminating the constant-voltage float mode after charge current has dropped below a specified level (typically around 10% of the full current) and a further time out period of 30 to 90 minutes has elapsed. This may extend battery life, so check with the manufacturer for details. The circuit in Figure 5 will detect when charge current has dropped below 270mA. This logic signal is used to initiate a timeout period, after which the LT1769 can be shut down by pulling the V_C pin low with an open collector or drain. Some external means must be used to detect the need for additional charging or the

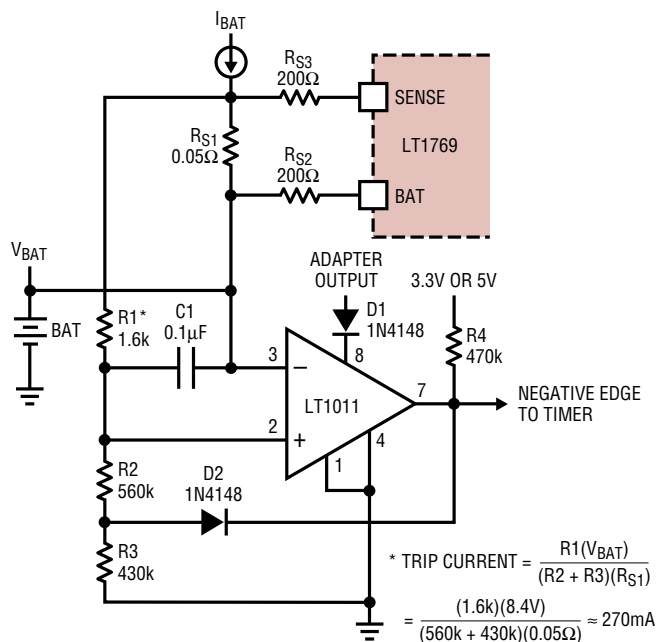

Figure 5. Current Comparator for Initiating Float Time Out

APPLICATIONS INFORMATION

charger may be turned on periodically to complete a short float-voltage cycle.

Current trip level is determined by the battery voltage, R1 through R3 and the sense resistor (R_{S1}). D2 generates hysteresis in the trip level to avoid multiple comparator transitions.

Nickel-Cadmium and Nickel-Metal-Hydrate Charging

The 2A Lithium-Ion Battery Charger shown in Figure 1 can be modified to charge NiCd or NiMH batteries. For example, if a 2-level charge is needed; 1A when Q1 is on and 100mA when Q1 is off.

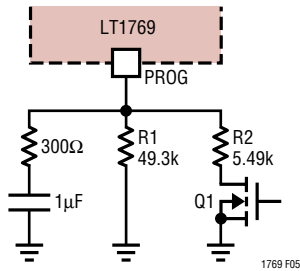

Figure 6. 2-Level Charging

For 1A full current, the current sense resistor (R_{S1}) should be increased to 0.1Ω so that enough signal (10mV) will be across R_{S1} at 0.1A trickle charge to keep charging current accurate.

For a 2-level charger, R1 and R2 are found from:

$$R1 = \frac{(2.465)(2000)}{I_{LOW}} \quad R2 = \frac{(2.465)(2000)}{I_{HI} - I_{LOW}}$$

All battery chargers with fast charge rates require some means to detect full charge in the battery and terminate the high charge current. NiCd batteries are typically charged at high current until a temperature rise or battery voltage decrease is detected as an indication of near full charge. The charging current is then reduced to a much lower value and maintained as a constant trickle charge. An intermediate “top off” current may also be used for a fixed time period to reduce total charge time.

NiMH batteries are similar in chemistry to NiCd but have two differences related to charging. First, the inflection characteristic in battery voltage as full charge is approached

is not nearly as pronounced. This makes it more difficult to use $-dV/dt$ as an indicator of full charge, and an increase in battery temperature is more often used with a temperature sensor in the battery pack. Secondly, constant trickle charge may not be recommended. Instead, a moderate level of current is used on a pulse basis ($\approx 1\%$ to 5% duty cycle) with the time-averaged value substituting for a constant low trickle. Please contact the Linear Technology Applications department about charge termination circuits.

If overvoltage protection is needed, R3 and R4 can be calculated according to the procedure described in Lithium-Ion Charging section. The OVP pin should be grounded if not used.

When a microprocessor DAC output is used to control charge current, it must be capable of sinking current at a compliance up to 2.5V if connected directly to the PROG pin.

Thermal Calculations

If the LT1769 is used for charging currents above 1A, a thermal calculation should be done to ensure that junction temperature will not exceed 125°C . Power dissipation in the IC is caused by bias and driver current, switch resistance and switch transition losses. The GN package, with a thermal resistance of 35°C/W , can provide a full 2A charging current in many situations. A graph is shown in the Typical Performance Characteristics section.

$$P_{BIAS} = (3.5\text{mA})(V_{IN}) + 1.5\text{mA}(V_{BAT}) + \frac{(V_{BAT})^2}{V_{IN}} [7.5\text{mA} + (0.012)(I_{BAT})]$$

$$P_{DRIVER} = \frac{(I_{BAT})(V_{BAT})^2 \left(1 + \frac{V_{BAT}}{30}\right)}{55(V_{IN})}$$

$$P_{SW} = \frac{(I_{BAT})^2 (R_{SW})(V_{BAT})}{V_{IN}} + (t_{OL})(V_{IN})(I_{BAT})(f)$$

R_{SW} = Switch ON resistance $\approx 0.16\Omega$

t_{OL} = Effective switch overlap time $\approx 10\text{ns}$

f = 200kHz

APPLICATIONS INFORMATION

Example: $V_{IN} = 19V$, $V_{BAT} = 12.6V$, $I_{BAT} = 2A$:

$$P_{BIAS} = (3.5mA)(19) + 1.5mA(12.6) + \frac{(12.6)^2}{19} [7.5mA + (0.012)(2000mA)] = 0.35W$$

$$P_{DRIVER} = \frac{(2)(12.6)^2 \left(1 + \frac{12.6}{30}\right)}{55(19)} = 0.43W$$

$$P_{SW} = \frac{(2)^2(0.16)(12.6)}{19} + 10^{-9}(19)(2)(200kHz) = 0.42 + 0.08 = 0.5W$$

Total Power in the IC is: $0.35 + 0.43 + 0.5 = 1.3W$
 Temperature rise will be $(1.3W)(35^{\circ}C/W) = 46^{\circ}C$. This assumes that the LT1769 is properly heat sunk by connecting the eleven fused ground pins to expanded traces and that the PC board has a backside or internal plane for heat spreading.

The P_{DRIVER} term can be reduced by connecting the boost diode D2 (see Figure 7) to a lower system voltage (lower than V_{BAT}) instead of V_{BAT} .

$$\text{Then } P_{DRIVER} = \frac{(I_{BAT})(V_{BAT})(V_X) \left(1 + \frac{V_X}{30}\right)}{55(V_{IN})}$$

For example, $V_X = 3.3V$ then:

$$P_{DRIVER} = \frac{(2A)(12.6V)(3.3V) \left(1 + \frac{3.3V}{30}\right)}{55(19V)} = 0.09W$$

The average I_{VX} required is:

$$\frac{P_{DRIVER}}{V_X} = \frac{0.09W}{3.3V} = 28mA$$

The previous example shows the dramatic drop in driver power dissipation when the boost diode (D2) is connected to an external 3.3V source instead of the 12.6V battery. P_{DRIVER} drops from 0.43W to 0.09W resulting in an approximately $12^{\circ}C$ drop in junction temperature.

Fused-lead packages conduct most of their heat out the leads. This makes it very important to provide as much PC board copper around the leads as is practical. Total

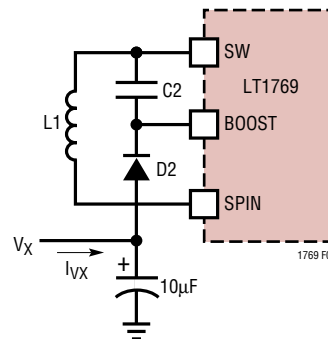

Figure 7. Lower V_{BOOST}

thermal resistance of the package-board combination is dominated by the characteristics of the board in the immediate area of the package. This means both lateral thermal resistance across the board and vertical thermal resistance through the board to other copper layers. Each layer acts as a thermal heat spreader that increases the heat sinking effectiveness of extended areas of the board.

Total board area becomes an important factor when the area of the board drops below about 20 square inches. The graph in Figure 8 shows thermal resistance vs board area for 2-layer and 4-layer boards with continuous copper planes. Note that 4-layer boards have significantly lower thermal resistance, but both types show a rapid increase for reduced board areas. Figure 9 shows actual measured lead temperatures for chargers operating at full current. Battery voltage and input voltage will affect device power dissipation, so the data sheet power calculations must be used to extrapolate these readings to other situations.

Vias should be used to connect board layers together. Planes under the charger area can be cut away from the rest of the board and connected with vias to form both a low thermal resistance system and to act as a ground plane for reduced EMI.

Glue-on, chip-mounted heat sinks are effective only in moderate power applications where the PC board copper cannot be used, or where the board size is small. They offer very little improvement in a properly laid out multilayer board of reasonable size.

Higher Duty Cycle for the LT1769 Battery Charger

Maximum duty cycle for the LT1769 is typically 90%, but this may be too low for some applications. For example, if

APPLICATIONS INFORMATION

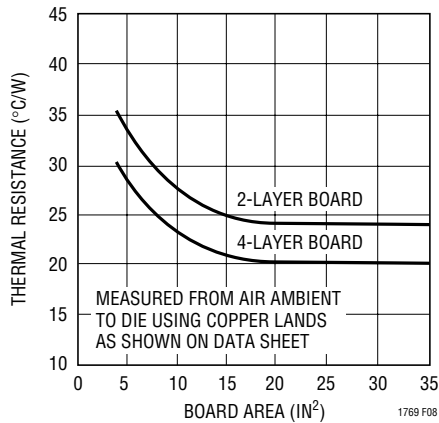

Figure 8. LT1769 Thermal Resistance

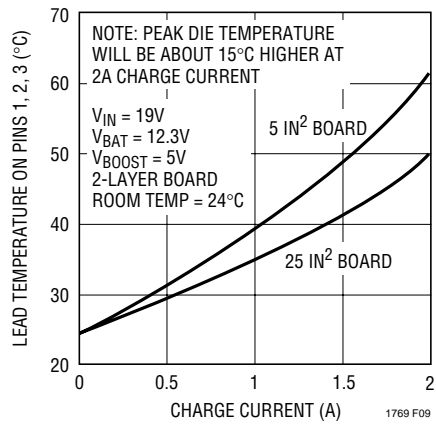

Figure 9. LT1769 Lead Temperature

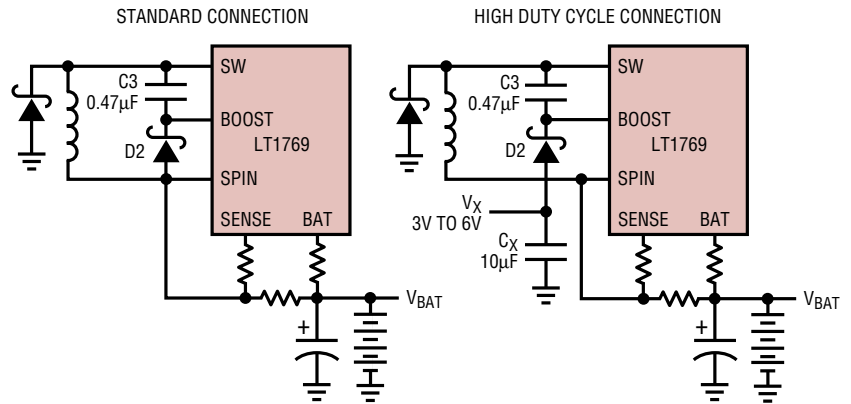

Figure 10. High Duty Cycle

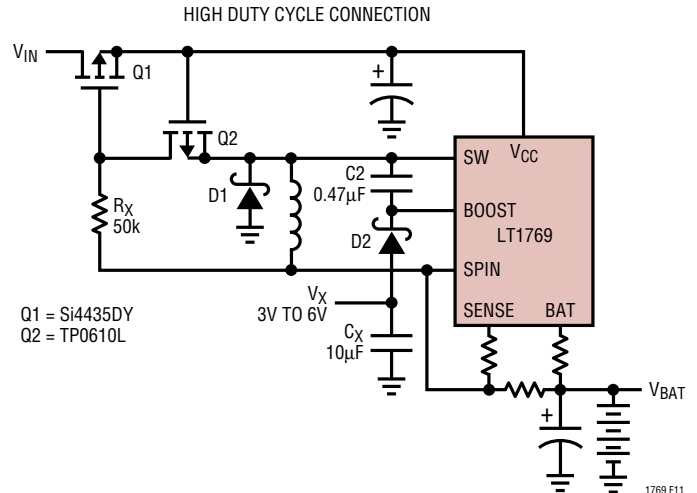

Figure 11. Replacing the Input Diode

an $18V \pm 3\%$ adapter is used to charge ten NiMH cells, the charger must put out approximately 15V. A total of 1.6V is lost in the input diode, switch resistance, inductor resistance and parasitics, so the required duty cycle is $15/16.4 = 91.4\%$. The duty cycle can be extended to 93% by restricting boost voltage to 5V instead of using V_{BAT} as is normally done. This lower boost voltage also reduces power dissipation in the LT1769, so it is a win-win decision. Connect an external source of 3V to 6V at V_X node in Figure 10 with a $10\mu F$ C_X bypass capacitor.

Lower Dropout Voltage

For even lower dropout and/or reducing heat on the board, the input diode D3 can be replaced with a FET (see Figure 11). Connect a P-channel FET in place of the input diode

with its gate connected to the battery causing the FET to turn off when the input voltage goes low. The problem is that the gate must be pumped low so that the FET is fully turned on even when the input is only a volt or two above the battery voltage. Also there is a turn-off speed issue. The FET should turn off instantly when the input is dead shorted to avoid large current surges from the battery back through the charger into the FET. Gate capacitance slows turn-off, so a small P-channel (Q2) is added to discharge the gate capacitance quickly in the event of an input short. The Q2 body diode creates the necessary pumping action to keep the gate of Q1 low during normal operation. Note that Q1 and Q2 have a V_{GS} spec limit of 20V. This restricts V_{IN} to a maximum of 20V. For low dropout operation with $V_{IN} > 20V$ consult factory.

APPLICATIONS INFORMATION

Optional Diode Connections

The typical application in Figure 1 shows a single diode (D3) to isolate the V_{CC} pin from the adaptor input and to block reverse input voltage (both steady state and transient). This simple connection may be unacceptable in situations where the system load must be powered from the battery when the adaptor input power is removed. As shown in Figure 12, a parasitic diode exists from the SW pin to the V_{CC} pin in the LT1769. When the input power is removed, this diode will become forward biased and will provide a current path from the battery to the system load. Because of diode power limitations, it is not recommended to power the system load through the internal parasitic diode. To safely power the system load from the battery, an additional Schottky diode (D4) is needed. For minimum losses, D4 could be replaced by a low $R_{DS(ON)}$ MOSFET which is turned on when the adaptor power is removed.

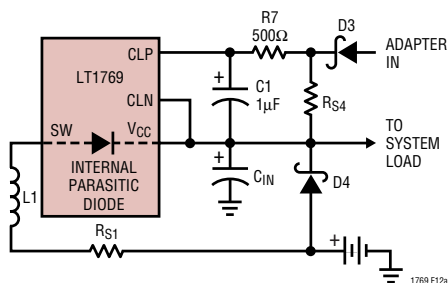

Figure 12. Modified Diode Connection

Layout Considerations

Switch rise and fall times are under 10ns for maximum efficiency. To minimize radiation, the catch diode, SW pin and input bypass capacitor leads should be kept as short as possible. A ground plane should be used under the switching circuitry to prevent interplane coupling and to act as a thermal spreading path. All ground pins should be connected to expanded traces for low thermal resistance. The fast-switching high current ground path, including the switch, catch diode and input capacitor, should be kept very short. Catch diode and input capacitor should be close to the chip and terminated to the same point. This path contains nanosecond rise and fall times with several amps of current. The other paths contain only DC and/or 200kHz tri-wave and are less critical. Figure 13 indicates the high speed, high current switching path. Figure 14 shows critical path layout. Contact Linear Technology for the LT1769 circuit PCB layout or Gerber file.

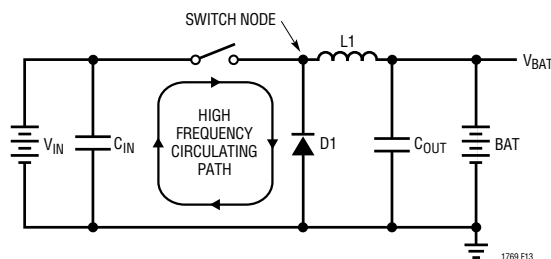
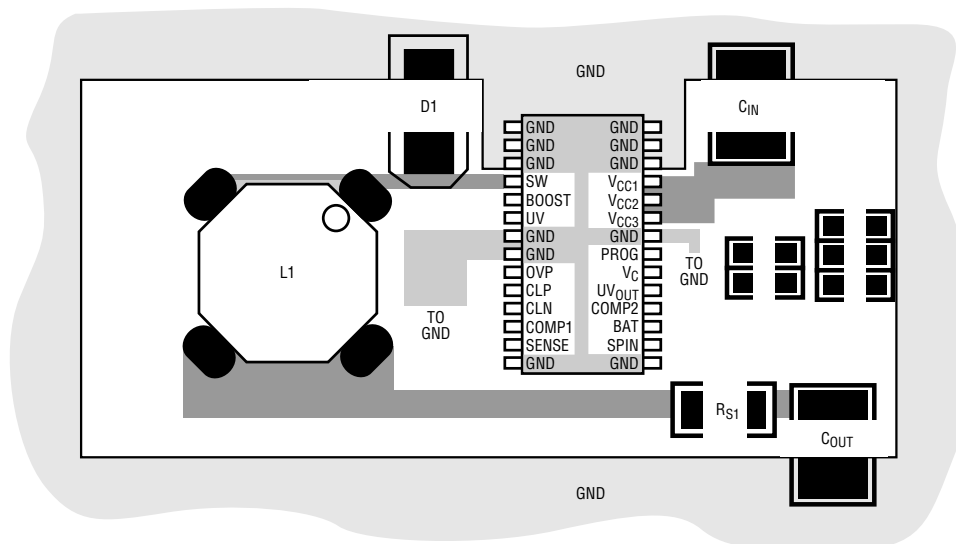

Figure 13. High Speed Switching Path



NOTE: CONNECT ALL GND PINS TO EXPANDED PC LANDS FOR PROPER HEAT SINKING

Figure 14. Critical Electrical and Thermal Path Layout

PACKAGE DESCRIPTION

FE Package 20-Lead Plastic TSSOP (4.4mm) (Reference LTC DWG # 05-08-1663) Exposed Pad Variation CB

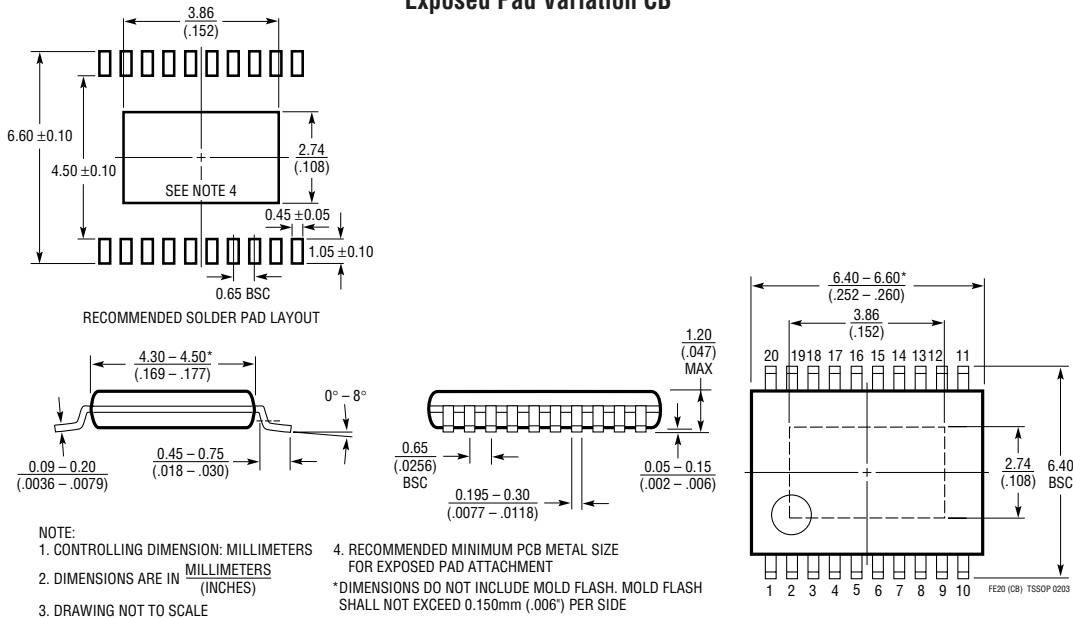

GN Package 28-Lead Plastic SSOP (Narrow .150 Inch) (Reference LTC DWG # 05-08-1641)

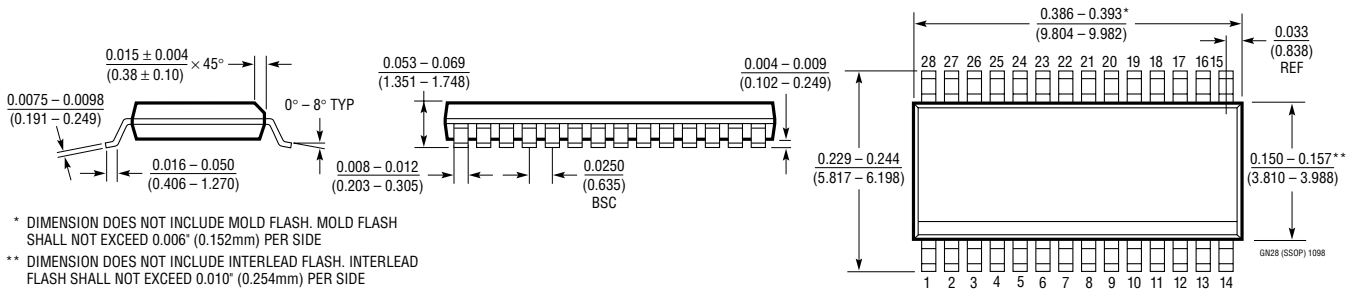

RELATED PARTS

PART NUMBER	DESCRIPTION	COMMENTS
LT1372/LT1377	500kHz/1MHz Step-Up Switching Regulators	High Frequency, Small Inductor, High Efficiency Switchers, 1.5A Switch
LT1376	500kHz Step-Down Switching Regulator	High Frequency, Small Inductor, High Efficiency Switcher, 1.5A Switch
LT1505	High Current, High Efficiency Battery Charger	94% Efficiency, Synchronous Current Mode PWM
LT1510	Constant-Voltage/Constant-Current Battery Charger	Up to 1.5A Charge Current for Lithium-Ion, NiCd and NiMH Batteries
LT1511	Constant-Voltage/Constant-Current Battery Charger	Up to 3A Charge Current for Lithium-Ion, NiCd and NiMH Batteries
LT1512/LT1513	SEPIC Battery Chargers	V _{IN} Can Be Higher or Lower Than Battery Voltage
LTC1729	Li-Ion Battery Charger Termination Controller	Preconditioning If Cell < 2.7V, 3hr Time-Out, C/10 Detection, Temp Sensor Pin, Charger and Battery Detection
LTC1759	SMBus Smart Battery Charger	94% Efficiency with Input Current Limiting, Up to 8A I _{CHG}
LTC1960	Dual Battery Charger and Selector with SPI Interface	I _{CHARGE} Up to 6A, Fast Charge, Longer Battery Life, Crisis Management

Looking for pricing, stock, or lifecycle information?

Click below to explore more details on WIN SOURCE:

 [View LT1769CFE#PBF on WIN SOURCE](#)

 [Linear Technology](#) Information

Optimize Your Supply Chain with WIN SOURCE Solutions

-  Global Sourcing Solution
-  Obsolete Management
-  Cost Control Management
-  Shortage Management
-  Alternative Solution
-  Excess Inventory Management