



**THE DATASHEET OF  
LT1913EDD#PBF**



## FEATURES

- **Wide Input Range: 3.6V to 25V**
- **3.5A Maximum Output Current**
- **Adjustable Switching Frequency: 200kHz to 2.4MHz**
- **Low Shutdown Current:  $I_Q < 1\mu\text{A}$**
- **Integrated Boost Diode**
- **Synchronizable Between 250kHz to 2MHz**
- Power Good Flag
- Saturating Switch Design:  $95\text{m}\Omega$  On-Resistance
- 0.790V Feedback Reference Voltage
- Output Voltage: 0.79V to 25V
- Thermal Protection
- Soft-Start Capability
- Small 10-Pin (3mm × 3mm) DFN Packages

## DESCRIPTION

The LT<sup>®</sup>1913 is an adjustable frequency (200kHz to 2.4MHz) monolithic buck switching regulator that accepts input voltages up to 25V. A high efficiency  $95\text{m}\Omega$  switch is included on the die along with a boost Schottky diode and the necessary oscillator, control, and logic circuitry. Current mode topology is used for fast transient response and good loop stability. Shutdown reduces input supply current to less than  $1\mu\text{A}$  while a resistor and capacitor on the RUN/SS pin provide a controlled output voltage ramp (soft-start). A power good flag signals when  $V_{\text{OUT}}$  reaches 91% of the programmed output voltage. The LT1913 is available in 10-Pin 3mm × 3mm DFN packages with exposed pads for low thermal resistance.

 LT, LTC and LTM are registered trademarks of Linear Technology Corporation. All other trademarks are the property of their respective owners.

## APPLICATIONS

- Automotive Battery Regulation
- Power for Portable Products
- Distributed Supply Regulation
- Industrial Supplies
- Wall Transformer Regulation

## TYPICAL APPLICATION

**5V Step-Down Converter**

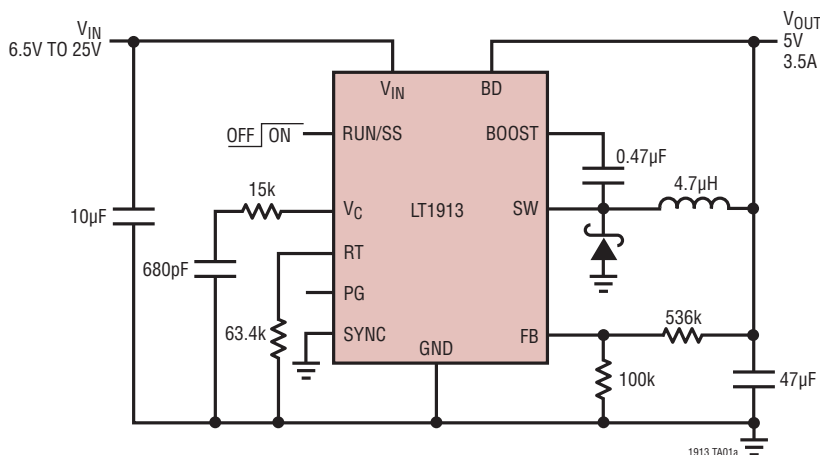

**Efficiency**

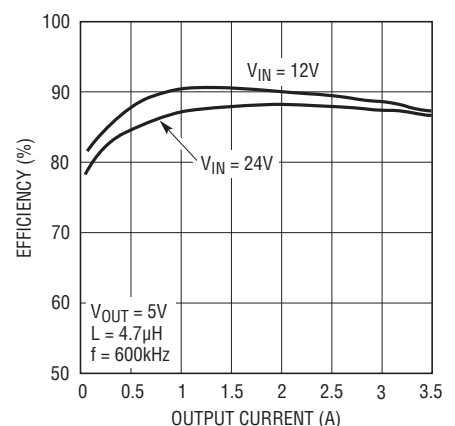

1913 TA012

1913 G01

1913f

# LT1913

## ABSOLUTE MAXIMUM RATINGS (Note 1)

$V_{IN}$ , RUN/SS Voltage.....	25V	SYNC Voltage.....	20V
BOOST Pin Voltage.....	50V	Operating Junction Temperature Range (Note 2)	
BOOST Pin Above SW Pin.....	25V	LT1913E.....	-40°C to 125°C
FB, RT, $V_C$ Voltage.....	5V	LT1913I.....	-40°C to 125°C
PG, BD Voltage.....	25V	Storage Temperature Range.....	-65°C to 150°C

## PIN CONFIGURATION

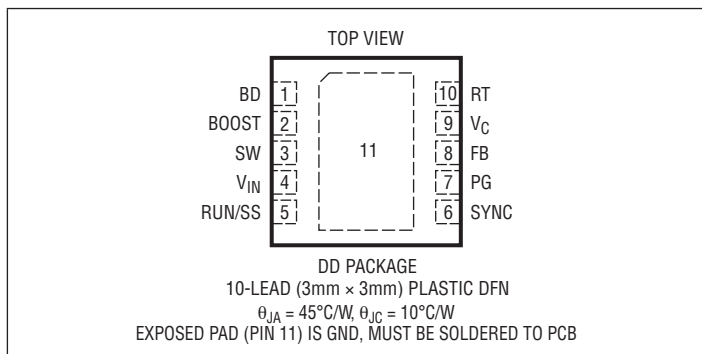

## ORDER INFORMATION

LEAD FREE FINISH	TAPE AND REEL	PART MARKING*	PACKAGE DESCRIPTION	TEMPERATURE RANGE
LT1913EDD#PBF	LT1913EDD#TRPBF	LDJW	10-Lead (3mm × 3mm) Plastic DFN	-40°C to 125°C
LT1913IDD#PBF	LT1913IDD#TRPBF	LDJW	10-Lead (3mm × 3mm) Plastic DFN	-40°C to 125°C

Consult LTC Marketing for parts specified with wider operating temperature ranges. \*The temperature grade is identified by a label on the shipping container. Consult LTC Marketing for information on non-standard lead based finish parts.

For more information on lead free part marking, go to: <http://www.linear.com/leadfree/>

For more information on tape and reel specifications, go to: <http://www.linear.com/tapeandreel/>

## ELECTRICAL CHARACTERISTICS

The ● denotes the specifications which apply over the full operating temperature range, otherwise specifications are at  $T_A = 25^{\circ}\text{C}$ .  $V_{IN} = 10\text{V}$ ,  $V_{RUN/SS} = 10\text{V}$ ,  $V_{BOOST} = 15\text{V}$ ,  $V_{BD} = 3.3\text{V}$  unless otherwise noted. (Note 2)

PARAMETER	CONDITIONS	MIN	TYP	MAX	UNITS
Minimum Input Voltage		●	3	3.6	V
Quiescent Current from $V_{IN}$	$V_{RUN/SS} = 0.2\text{V}$		0.01	0.5	$\mu\text{A}$
	$V_{BD} = 3\text{V}$ , Not Switching	●	0.45	1.2	$\text{mA}$
	$V_{BD} = 0$ , Not Switching		1.3	2.3	$\text{mA}$
Quiescent Current from BD	$V_{RUN/SS} = 0.2\text{V}$		0.01	0.5	$\mu\text{A}$
	$V_{BD} = 3\text{V}$ , Not Switching	●	0.9	1.8	$\text{mA}$
	$V_{BD} = 0$ , Not Switching		1	10	$\mu\text{A}$
Minimum Bias Voltage (BD Pin)			2.7	3	V

1913f

**ELECTRICAL CHARACTERISTICS** The ● denotes the specifications which apply over the full operating temperature range, otherwise specifications are at  $T_A = 25^\circ\text{C}$ .  $V_{IN} = 10\text{V}$ ,  $V_{RUN/SS} = 10\text{V}$ ,  $V_{BOOST} = 15\text{V}$ ,  $V_{BD} = 3.3\text{V}$  unless otherwise noted. (Note 2)

PARAMETER	CONDITIONS	MIN	TYP	MAX	UNITS	
Feedback Voltage		780 775	790 790	800 805	mV mV	
FB Pin Bias Current (Note 3)	$V_{FB} = 0.8\text{V}$ , $V_C = 0.4\text{V}$	●	10	40	nA	
FB Voltage Line Regulation	$4\text{V} < V_{IN} < 25\text{V}$		0.002	0.01	%/V	
Error Amp $g_m$			525		$\mu\text{Mho}$	
Error Amp Gain			2000			
$V_C$ Source Current			60		$\mu\text{A}$	
$V_C$ Sink Current			60		$\mu\text{A}$	
$V_C$ Pin to Switch Current Gain			5.3		A/V	
$V_C$ Clamp Voltage			2.0		V	
Switching Frequency	$R_T = 8.66\text{k}$ $R_T = 29.4\text{k}$ $R_T = 187\text{k}$	2.2 1.0 200	2.45 1.1 230	2.7 1.25 260	MHz MHz kHz	
Minimum Switch Off-Time		●	60	150	nS	
Switch Current Limit	Duty Cycle = 5%		4.6	5.4	6.0	A
Switch $V_{CESAT}$	$I_{SW} = 3.5\text{A}$		335		mV	
Boost Schottky Reverse Leakage	$V_{SW} = 10\text{V}$ , $V_{BD} = 0\text{V}$		0.02	2	$\mu\text{A}$	
Minimum Boost Voltage (Note 4)		●	1.5	2.0	V	
BOOST Pin Current	$I_{SW} = 1\text{A}$		35	60	mA	
RUN/SS Pin Current	$V_{RUN/SS} = 2.5\text{V}$		5	8	$\mu\text{A}$	
RUN/SS Input Voltage High				2.5	V	
RUN/SS Input Voltage Low		0.2			V	
PG Threshold Offset from Feedback Voltage	$V_{FB}$ Rising		65		mV	
PG Hysteresis			10		mV	
PG Leakage	$V_{PG} = 5\text{V}$		0.1	1	$\mu\text{A}$	
PG Sink Current	$V_{PG} = 0.4\text{V}$	●	200	800	$\mu\text{A}$	
SYNC Low Threshold		0.5			V	
SYNC High Threshold				0.8	V	
SYNC Pin Bias Current	$V_{SYNC} = 0\text{V}$		0.1		$\mu\text{A}$	

**Note 1:** Stresses beyond those listed under Absolute Maximum Ratings may cause permanent damage to the device. Exposure to any Absolute Maximum Rating condition for extended periods may affect device reliability and lifetime.

**Note 2:** The LT1913E is guaranteed to meet performance specifications from  $0^\circ\text{C}$  to  $125^\circ\text{C}$ . Specifications over the  $-40^\circ\text{C}$  to  $125^\circ\text{C}$  operating temperature range are assured by design, characterization and correlation with statistical process controls. The LT1913I specifications are guaranteed over the  $-40^\circ\text{C}$  to  $125^\circ\text{C}$  temperature range.

**Note 3:** Bias current flows out of the FB pin.

**Note 4:** This is the minimum voltage across the boost capacitor needed to guarantee full saturation of the switch.

**TYPICAL PERFORMANCE CHARACTERISTICS**  $T_A = 25^\circ\text{C}$  unless otherwise noted.

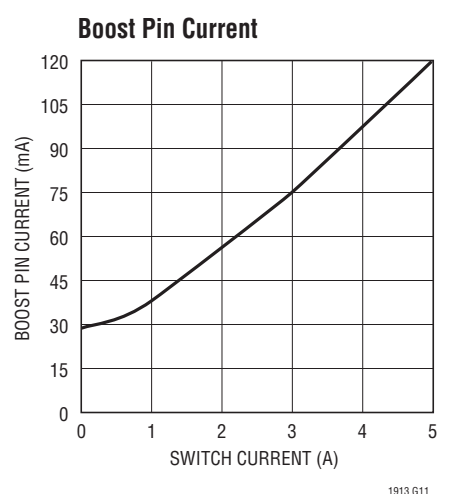
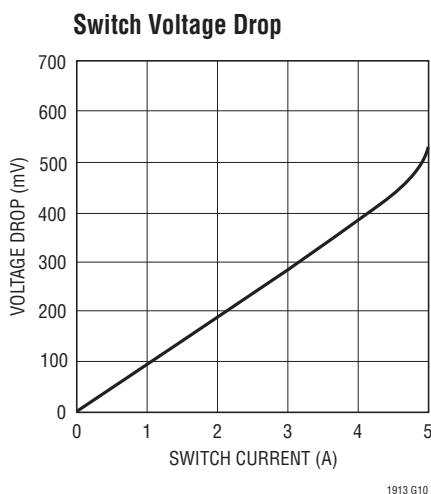
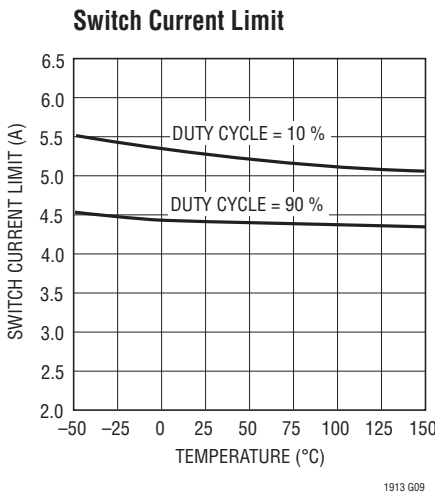
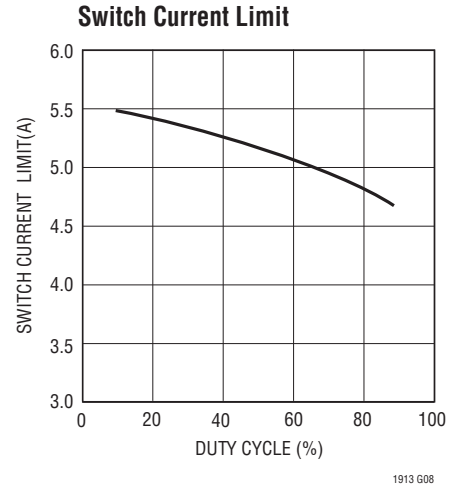
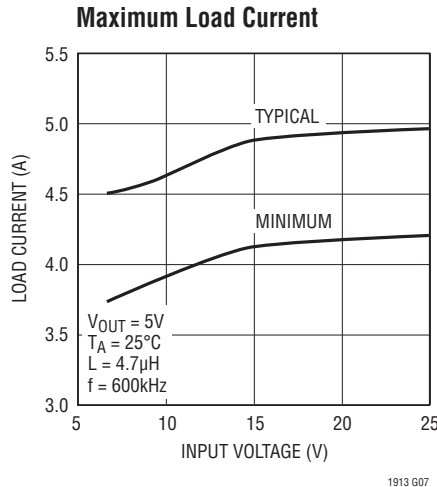
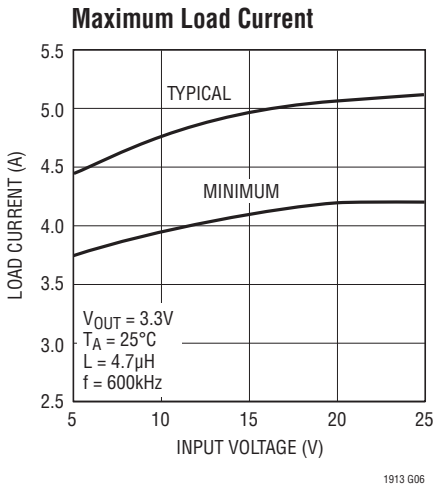
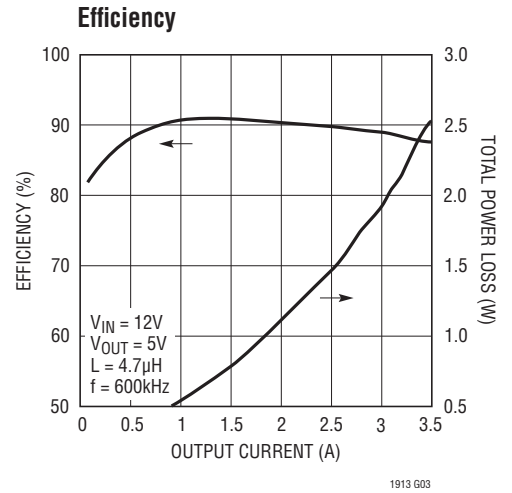
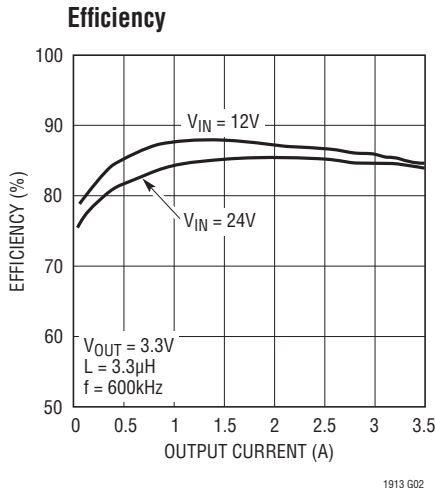
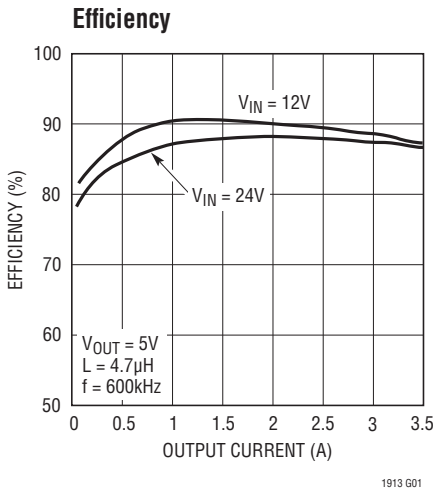

**TYPICAL PERFORMANCE CHARACTERISTICS**  $T_A = 25^\circ\text{C}$  unless otherwise noted.

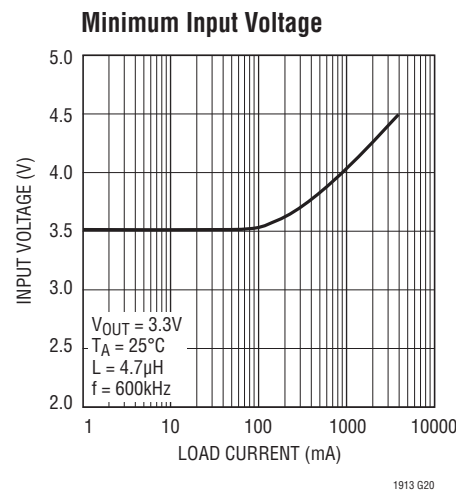
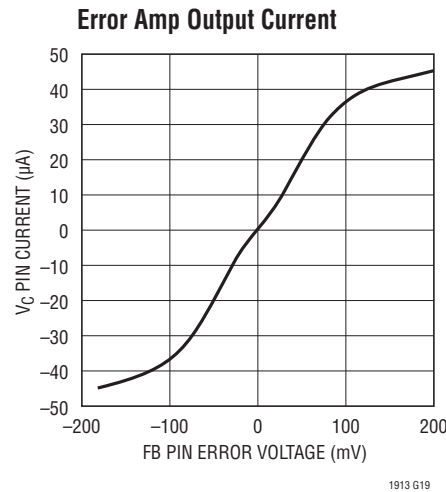
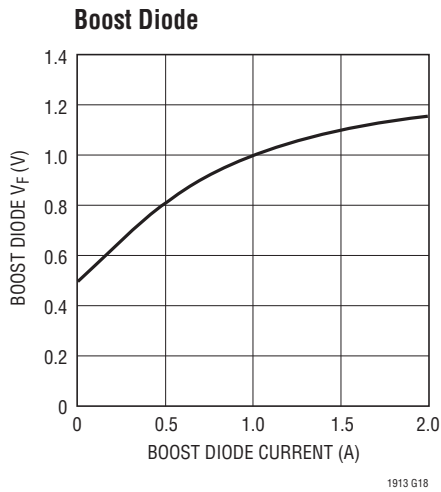
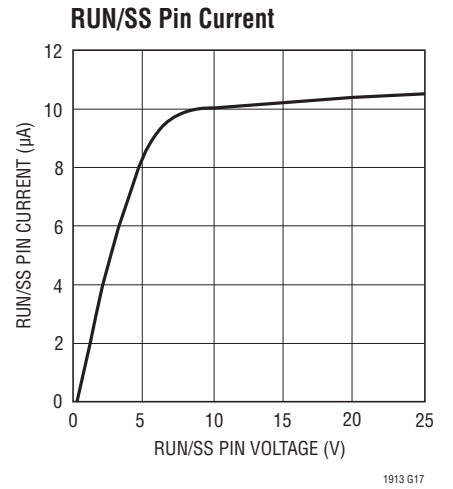
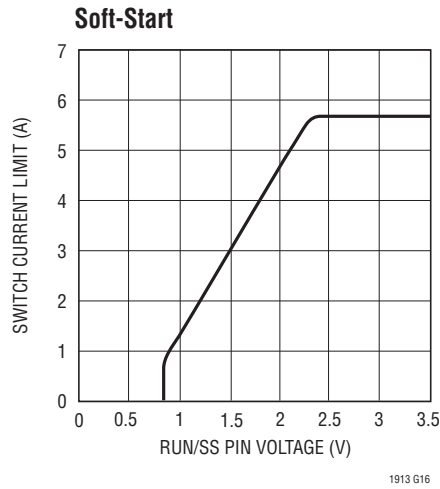
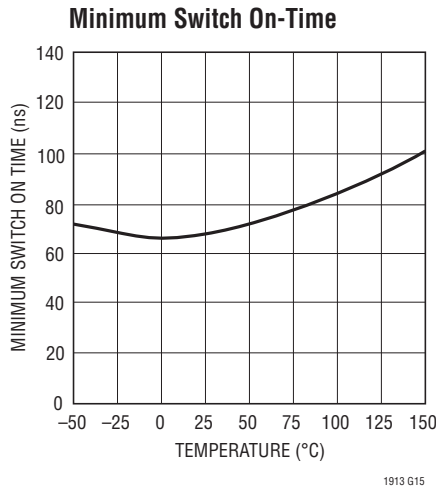
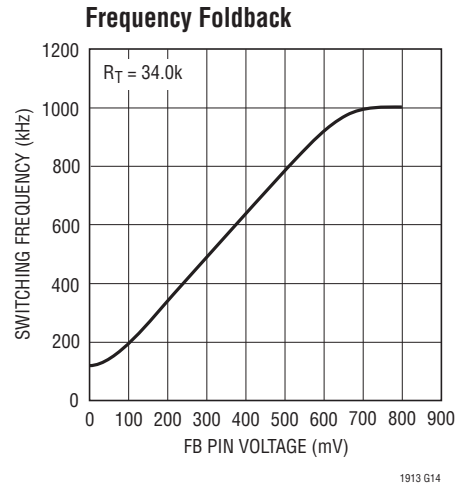
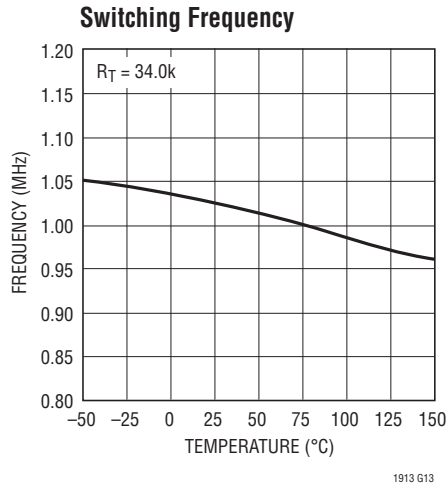
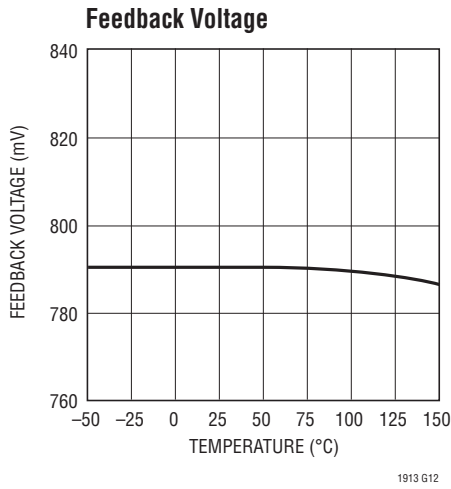

**TYPICAL PERFORMANCE CHARACTERISTICS**  $T_A = 25^\circ\text{C}$  unless otherwise noted.

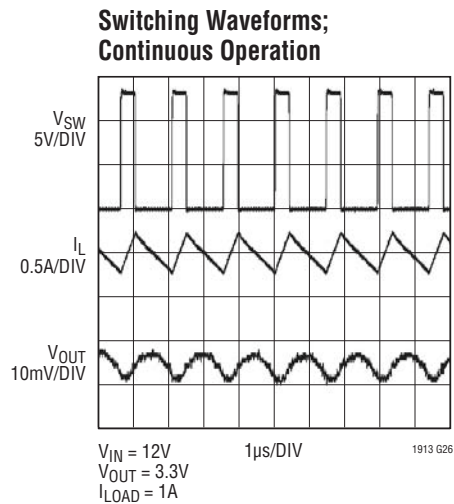
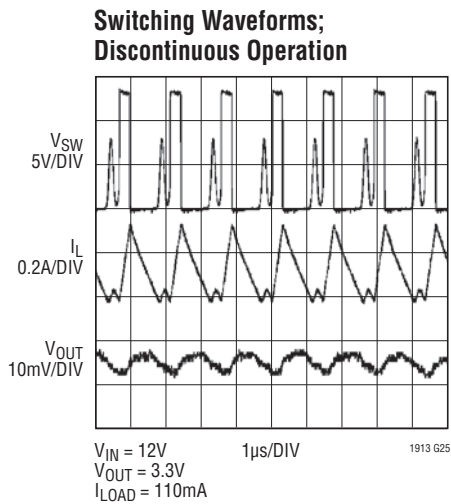
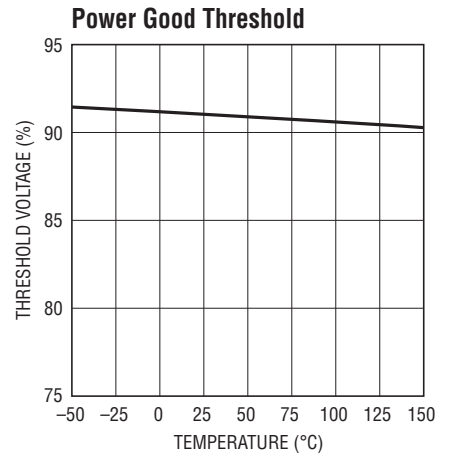
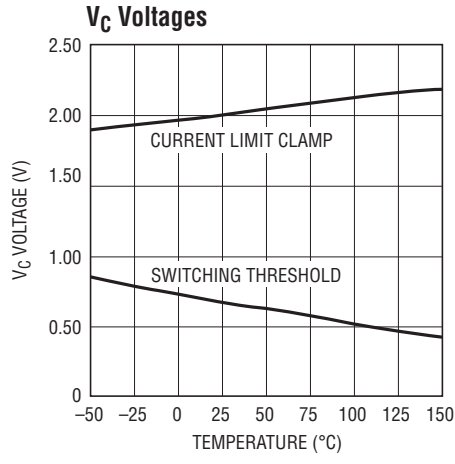
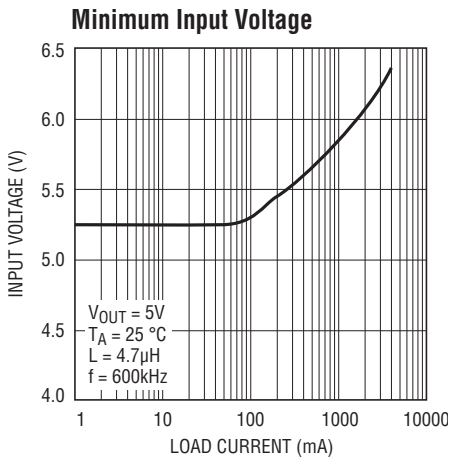

## PIN FUNCTIONS

**BD (Pin 1):** This pin connects to the anode of the boost Schottky diode. BD also supplies current to the internal regulator.

**BOOST (Pin 2):** This pin is used to provide a drive voltage, higher than the input voltage, to the internal bipolar NPN power switch.

**SW (Pin 3):** The SW pin is the output of the internal power switch. Connect this pin to the inductor, catch diode and boost capacitor.

**V<sub>IN</sub> (Pin 4):** The V<sub>IN</sub> pin supplies current to the LT1913's internal regulator and to the internal power switch. This pin must be locally bypassed.

**RUN/SS (Pin 5):** The RUN/SS pin is used to put the LT1913 in shutdown mode. Tie to ground to shut down the LT1913. Tie to 2.5V or more for normal operation. If the shutdown feature is not used, tie this pin to the V<sub>IN</sub> pin. RUN/SS also provides a soft-start function; see the Applications Information section.

**SYNC (Pin 6):** This is the external clock synchronization input. Ground this pin when not used. Tie to a clock source for synchronization. Clock edges should have rise and fall times faster than 1 $\mu$ s. Do not leave pin floating. See synchronizing section in Applications Information.

**PG (Pin 7):** The PG pin is the open collector output of an internal comparator. PG remains low until the FB pin is within 9% of the final regulation voltage. PG output is valid when V<sub>IN</sub> is above 3.6V and RUN/SS is high.

**FB (Pin 8):** The LT1913 regulates the FB pin to 0.790V. Connect the feedback resistor divider tap to this pin.

**V<sub>C</sub> (Pin 9):** The V<sub>C</sub> pin is the output of the internal error amplifier. The voltage on this pin controls the peak switch current. Tie an RC network from this pin to ground to compensate the control loop.

**RT (Pin 10):** Oscillator Resistor Input. Connecting a resistor to ground from this pin sets the switching frequency.

**Exposed Pad (Pin 11):** Ground. The Exposed Pad must be soldered to PCB.

**BLOCK DIAGRAM**

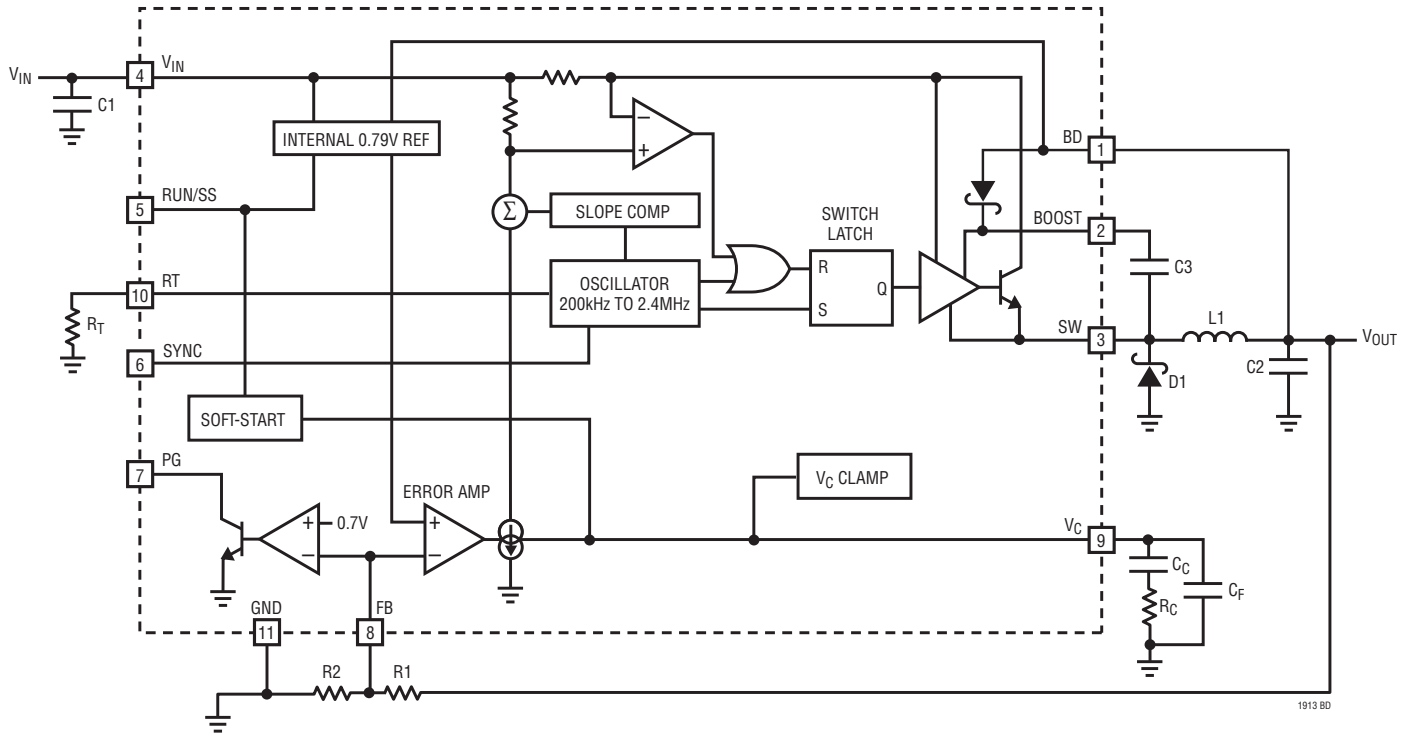

## OPERATION

The LT1913 is a constant frequency, current mode step-down regulator. An oscillator, with frequency set by  $R_T$ , enables an RS flip-flop, turning on the internal power switch. An amplifier and comparator monitor the current flowing between the  $V_{IN}$  and SW pins, turning the switch off when this current reaches a level determined by the voltage at  $V_C$ . An error amplifier measures the output voltage through an external resistor divider tied to the FB pin and servos the  $V_C$  pin. If the error amplifier's output increases, more current is delivered to the output; if it decreases, less current is delivered. An active clamp on the  $V_C$  pin provides current limit. The  $V_C$  pin is also clamped to the voltage on the RUN/SS pin; soft-start is implemented by generating a voltage ramp at the RUN/SS pin using an external resistor and capacitor.

An internal regulator provides power to the control circuitry. The bias regulator normally draws power from the  $V_{IN}$  pin, but if the BD pin is connected to an external voltage higher than 3V bias power will be drawn from the external source (typically the regulated output voltage). This improves

efficiency. The RUN/SS pin is used to place the LT1913 in shutdown, disconnecting the output and reducing the input current to less than  $0.5\mu\text{A}$ .

The switch driver operates from either the input or from the BOOST pin. An external capacitor and diode are used to generate a voltage at the BOOST pin that is higher than the input supply. This allows the driver to fully saturate the internal bipolar NPN power switch for efficient operation.

The oscillator reduces the LT1913's operating frequency when the voltage at the FB pin is low. This frequency foldback helps to control the output current during startup and overload.

The LT1913 contains a power good comparator which trips when the FB pin is at 91% of its regulated value. The PG output is an open-collector transistor that is off when the output is in regulation, allowing an external resistor to pull the PG pin high. Power good is valid when the LT1913 is enabled and  $V_{IN}$  is above 3.6V.

## APPLICATIONS INFORMATION

### FB Resistor Network

The output voltage is programmed with a resistor divider between the output and the FB pin. Choose the 1% resistors according to:

$$R1 = R2 \left( \frac{V_{OUT}}{0.79V} - 1 \right)$$

Reference designators refer to the Block Diagram.

### Setting the Switching Frequency

The LT1913 uses a constant frequency PWM architecture that can be programmed to switch from 200kHz to 2.4MHz by using a resistor tied from the RT pin to ground. A table showing the necessary RT value for a desired switching frequency is in Figure 1.

SWITCHING FREQUENCY (MHz)	RT VALUE (kΩ)
0.2	215
0.3	140
0.4	100
0.5	78.7
0.6	63.4
0.7	53.6
0.8	45.3
0.9	39.2
1.0	34
1.2	26.7
1.4	22.1
1.6	18.2
1.8	15
2.0	12.7
2.2	10.7
2.4	9.09

Figure 1. Switching Frequency vs. RT Value

### Operating Frequency Tradeoffs

Selection of the operating frequency is a tradeoff between efficiency, component size, minimum dropout voltage, and maximum input voltage. The advantage of high frequency operation is that smaller inductor and capacitor values may be used. The disadvantages are lower efficiency, lower maximum input voltage, and higher dropout voltage. The highest acceptable switching frequency ( $f_{SW(MAX)}$ ) for a given application can be calculated as follows:

$$f_{SW(MAX)} = \frac{V_D + V_{OUT}}{t_{ON(MIN)} (V_D + V_{IN} - V_{SW})}$$

where  $V_{IN}$  is the typical input voltage,  $V_{OUT}$  is the output voltage,  $V_D$  is the catch diode drop (~0.5V) and  $V_{SW}$  is the internal switch drop (~0.5V at max load). This equation shows that slower switching frequency is necessary to safely accommodate high  $V_{IN}/V_{OUT}$  ratio. Also, as shown in the next section, lower frequency allows a lower dropout voltage. The reason input voltage range depends on the switching frequency is because the LT1913 switch has finite minimum on and off times. The switch can turn on for a minimum of ~150ns and turn off for a minimum of ~150ns. Typical minimum on time at 25°C is 80ns. This means that the minimum and maximum duty cycles are:

$$DC_{MIN} = f_{SW} t_{ON(MIN)}$$

$$DC_{MAX} = 1 - f_{SW} t_{OFF(MIN)}$$

where  $f_{SW}$  is the switching frequency, the  $t_{ON(MIN)}$  is the minimum switch on time (~150ns), and the  $t_{OFF(MIN)}$  is the minimum switch off time (~150ns). These equations show that duty cycle range increases when switching frequency is decreased.

A good choice of switching frequency should allow adequate input voltage range (see next section) and keep the inductor and capacitor values small.

### Input Voltage Range

The maximum input voltage for LT1913 applications depends on switching frequency and Absolute Maximum Ratings of the  $V_{IN}$  and BOOST pins (25V and 50V respectively).

While the output is in start-up, short-circuit, or other overload conditions, the switching frequency should be chosen according to the following equation:

$$V_{IN(MAX)} = \frac{V_{OUT} + V_D}{f_{SW} t_{ON(MIN)}} - V_D + V_{SW}$$

where  $V_{IN(MAX)}$  is the maximum operating input voltage,  $V_{OUT}$  is the output voltage,  $V_D$  is the catch diode drop (~0.5V),  $V_{SW}$  is the internal switch drop (~0.5V at max load),  $f_{SW}$  is the switching frequency (set by  $R_T$ ), and  $t_{ON(MIN)}$  is the minimum switch on time (~100ns). Note that a higher switching frequency will depress the maximum

## APPLICATIONS INFORMATION

operating input voltage. Conversely, a lower switching frequency will be necessary to achieve safe operation at high input voltages.

If the output is in regulation and no short-circuit, start-up, or overload events are expected, then input voltage transients of up to 25V are acceptable regardless of the switching frequency. In this mode, the LT1913 may enter pulse skipping operation where some switching pulses are skipped to maintain output regulation. In this mode the output voltage ripple and inductor current ripple will be higher than in normal operation.

The minimum input voltage is determined by either the LT1913's minimum operating voltage of ~3.6V or by its maximum duty cycle (see equation in previous section). The minimum input voltage due to duty cycle is:

$$V_{IN(MIN)} = \frac{V_{OUT} + V_D}{1 - f_{SW} t_{OFF(MIN)}} - V_D + V_{SW}$$

where  $V_{IN(MIN)}$  is the minimum input voltage, and  $t_{OFF(MIN)}$  is the minimum switch off time (150ns). Note that higher switching frequency will increase the minimum input voltage. If a lower dropout voltage is desired, a lower switching frequency should be used.

### Inductor Selection

For a given input and output voltage, the inductor value and switching frequency will determine the ripple current. The ripple current  $\Delta I_L$  increases with higher  $V_{IN}$  or  $V_{OUT}$  and decreases with higher inductance and faster switching frequency. A reasonable starting point for selecting the ripple current is:

$$\Delta I_L = 0.4(I_{OUT(MAX)})$$

where  $I_{OUT(MAX)}$  is the maximum output load current. To guarantee sufficient output current, peak inductor current must be lower than the LT1913's switch current limit ( $I_{LIM}$ ). The peak inductor current is:

$$I_{L(PEAK)} = I_{OUT(MAX)} + \Delta I_L/2$$

where  $I_{L(PEAK)}$  is the peak inductor current,  $I_{OUT(MAX)}$  is the maximum output load current, and  $\Delta I_L$  is the inductor

ripple current. The LT1913's switch current limit ( $I_{LIM}$ ) is 5.5A at low duty cycles and decreases linearly to 4.5A at DC = 0.8. The maximum output current is a function of the inductor ripple current:

$$I_{OUT(MAX)} = I_{LIM} - \Delta I_L/2$$

Be sure to pick an inductor ripple current that provides sufficient maximum output current ( $I_{OUT(MAX)}$ ).

The largest inductor ripple current occurs at the highest  $V_{IN}$ . To guarantee that the ripple current stays below the specified maximum, the inductor value should be chosen according to the following equation:

$$L = \left( \frac{V_{OUT} + V_D}{f_{SW} \Delta I_L} \right) \left( 1 - \frac{V_{OUT} + V_D}{V_{IN(MAX)}} \right)$$

where  $V_D$  is the voltage drop of the catch diode (~0.4V),  $V_{IN(MAX)}$  is the maximum input voltage,  $V_{OUT}$  is the output voltage,  $f_{SW}$  is the switching frequency (set by RT), and L is in the inductor value.

The inductor's RMS current rating must be greater than the maximum load current and its saturation current should be about 30% higher. To keep the efficiency high, the series resistance (DCR) should be less than 0.05Ω, and the core material should be intended for high frequency applications. Table 1 lists several vendors and suitable types.

**Table 1. Inductor Vendors**

VENDOR	URL	PART SERIES	TYPE
Murata	<a href="http://www.murata.com">www.murata.com</a>	LQH55D	Open
TDK	<a href="http://www.componenttdk.com">www.componenttdk.com</a>	SLF10145	Shielded
Toko	<a href="http://www.toko.com">www.toko.com</a>	D75C D75F	Shielded Open
Sumida	<a href="http://www.sumida.com">www.sumida.com</a>	CDRH74 CR75 CDRH8D43	Shielded Open Shielded
NEC	<a href="http://www.nec.com">www.nec.com</a>	MPLC073 MPBI0755	Shielded Shielded

Of course, such a simple design guide will not always result in the optimum inductor for your application. A larger value inductor provides a slightly higher maximum load current and will reduce the output voltage ripple. If your

## APPLICATIONS INFORMATION

load is lower than 3.5A, then you can decrease the value of the inductor and operate with higher ripple current. This allows you to use a physically smaller inductor, or one with a lower DCR resulting in higher efficiency. There are several graphs in the Typical Performance Characteristics section of this data sheet that show the maximum load current as a function of input voltage and inductor value for several popular output voltages. Low inductance may result in discontinuous mode operation, which is okay but further reduces maximum load current. For details of maximum output current and discontinuous mode operation, see Linear Technology Application Note 44. Finally, for duty cycles greater than 50% ( $V_{OUT}/V_{IN} > 0.5$ ), there is a minimum inductance required to avoid subharmonic oscillations. See AN19.

### Input Capacitor

Bypass the input of the LT1913 circuit with a ceramic capacitor of X7R or X5R type. Y5V types have poor performance over temperature and applied voltage, and should not be used. A 10 $\mu$ F to 22 $\mu$ F ceramic capacitor is adequate to bypass the LT1913 and will easily handle the ripple current. Note that larger input capacitance is required when a lower switching frequency is used. If the input power source has high impedance, or there is significant inductance due to long wires or cables, additional bulk capacitance may be necessary. This can be provided with a lower performance electrolytic capacitor.

Step-down regulators draw current from the input supply in pulses with very fast rise and fall times. The input capacitor is required to reduce the resulting voltage ripple at the LT1913 and to force this very high frequency switching current into a tight local loop, minimizing EMI. A 10 $\mu$ F capacitor is capable of this task, but only if it is placed close to the LT1913 and the catch diode (see the PCB Layout section). A second precaution regarding the ceramic input capacitor concerns the maximum input voltage rating of the LT1913. A ceramic input capacitor combined with trace or cable inductance forms a high quality (under damped) tank circuit. If the LT1913 circuit

is plugged into a live supply, the input voltage can ring to twice its nominal value, possibly exceeding the LT1913's voltage rating. This situation is easily avoided (see the Hot Plugging Safety section).

For space sensitive applications, a 4.7 $\mu$ F ceramic capacitor can be used for local bypassing of the LT1913 input. However, the lower input capacitance will result in increased input current ripple and input voltage ripple, and may couple noise into other circuitry. Also, the increased voltage ripple will raise the minimum operating voltage of the LT1913 to ~3.7V.

### Output Capacitor and Output Ripple

The output capacitor has two essential functions. Along with the inductor, it filters the square wave generated by the LT1913 to produce the DC output. In this role it determines the output ripple, and low impedance at the switching frequency is important. The second function is to store energy in order to satisfy transient loads and stabilize the LT1913's control loop. Ceramic capacitors have very low equivalent series resistance (ESR) and provide the best ripple performance. A good starting value is:

$$C_{OUT} = \frac{100}{V_{OUT} f_{SW}}$$

where  $f_{SW}$  is in MHz, and  $C_{OUT}$  is the recommended output capacitance in  $\mu$ F. Use X5R or X7R types. This choice will provide low output ripple and good transient response. Transient performance can be improved with a higher value capacitor if the compensation network is also adjusted to maintain the loop bandwidth. A lower value of output capacitor can be used to save space and cost but transient performance will suffer. See the Frequency Compensation section to choose an appropriate compensation network.

When choosing a capacitor, look carefully through the data sheet to find out what the actual capacitance is under operating conditions (applied voltage and temperature). A physically larger capacitor, or one with a higher voltage

## APPLICATIONS INFORMATION

**Table 2. Capacitor Vendors**

VENDOR	PHONE	URL	PART SERIES	COMMANDS
Panasonic	(714) 373-7366	www.panasonic.com	Ceramic, Polymer, Tantalum	EEF Series
Kemet	(864) 963-6300	www.kemet.com	Ceramic, Tantalum	T494, T495
Sanyo	(408) 749-9714	www.sanyovideo.com	Ceramic, Polymer, Tantalum	POSCAP
Murata	(408) 436-1300	www.murata.com	Ceramic	
AVX		www.avxcorp.com	Ceramic, Tantalum	TPS Series
Taiyo Yuden	(864) 963-6300	www.taiyo-yuden.com	Ceramic	

rating, may be required. High performance tantalum or electrolytic capacitors can be used for the output capacitor. Low ESR is important, so choose one that is intended for use in switching regulators. The ESR should be specified by the supplier, and should be 0.05Ω or less. Such a capacitor will be larger than a ceramic capacitor and will have a larger capacitance, because the capacitor must be large to achieve low ESR. Table 2 lists several capacitor vendors.

### Catch Diode

The catch diode conducts current only during switch off time. Average forward current in normal operation can be calculated from:

$$I_{D(AVG)} = I_{OUT} (V_{IN} - V_{OUT})/V_{IN}$$

where  $I_{OUT}$  is the output load current. The only reason to consider a diode with a larger current rating than necessary for nominal operation is for the worst-case condition of shorted output. The diode current will then increase to the

typical peak switch current. Peak reverse voltage is equal to the regulator input voltage. Use a schottky diode with a reverse voltage rating greater than the input voltage. Table 3 lists several Schottky diodes and their manufacturers.

**Table 3. Diode Vendors**

PART NUMBER	$V_R$ (V)	$I_{AVE}$ (A)	$V_F$ AT 3A (mV)
On Semiconductor MBRA340	40	3	500
Diodes Inc. B330	30	3	500
B320	20	3	450

### Frequency Compensation

The LT1913 uses current mode control to regulate the output. This simplifies loop compensation. In particular, the LT1913 does not require the ESR of the output capacitor for stability, so you are free to use ceramic capacitors to achieve low output ripple and small circuit size. Frequency compensation is provided by the components tied to the

## APPLICATIONS INFORMATION

$V_C$  pin, as shown in Figure 2. Generally a capacitor ( $C_C$ ) and a resistor ( $R_C$ ) in series to ground are used. In addition, there may be lower value capacitor in parallel. This capacitor ( $C_F$ ) is not part of the loop compensation but is used to filter noise at the switching frequency, and is required only if a phase-lead capacitor is used or if the output capacitor has high ESR.

Loop compensation determines the stability and transient performance. Designing the compensation network is a bit complicated and the best values depend on the application and in particular the type of output capacitor. A practical approach is to start with one of the circuits in this data sheet that is similar to your application and tune the compensation network to optimize the performance. Stability should then be checked across all operating conditions, including load current, input voltage and temperature. The LT1375 data sheet contains a more thorough discussion of loop compensation and describes how to test the stability using a transient load. Figure 2 shows an equivalent circuit for the LT1913 control loop. The error amplifier is a transconductance amplifier with finite output impedance. The power section, consisting of the modulator, power switch and inductor, is modeled as a transconductance amplifier generating an output current proportional to the voltage at the  $V_C$  pin. Note that the output capacitor integrates this current, and that the capacitor on the  $V_C$  pin ( $C_C$ ) integrates the error amplifier output current, resulting in two poles in the loop. In most cases a zero is required and comes from either the output capacitor ESR or from a resistor  $R_C$  in series with  $C_C$ . This simple model works well as long as the value of the inductor is not too high and the loop crossover frequency is much lower than the switching frequency. A phase lead capacitor ( $C_{PL}$ ) across the feedback divider may improve the transient response. Figure 3 shows the transient response when the load current is stepped from 1A to 3A and back to 1A.

### BOOST and BIAS Pin Considerations

Capacitor C3 and the internal boost Schottky diode (see the Block Diagram) are used to generate a boost voltage that is higher than the input voltage. In most cases a  $0.47\mu\text{F}$  capacitor will work well. Figure 2 shows three ways to arrange the boost circuit. The BOOST pin must be

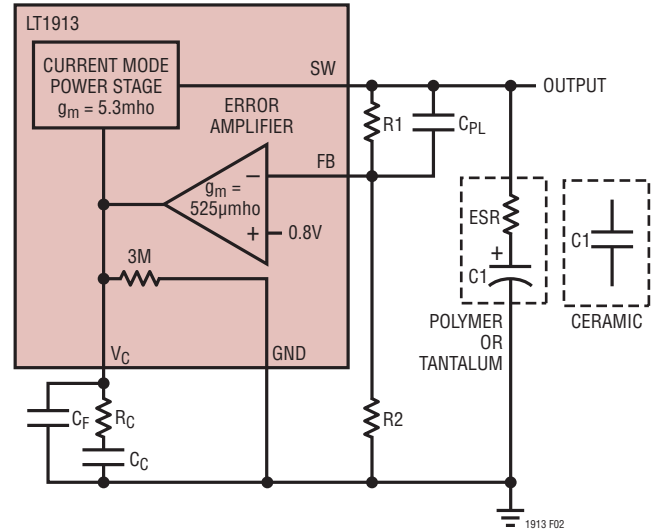

Figure 2. Model for Loop Response

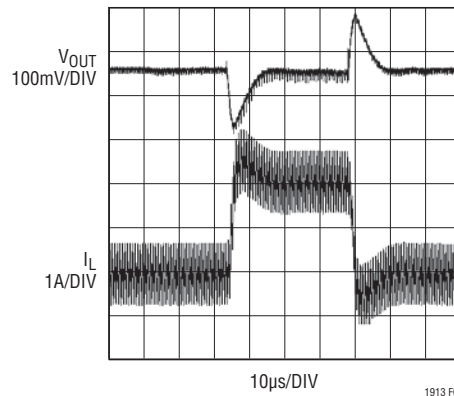
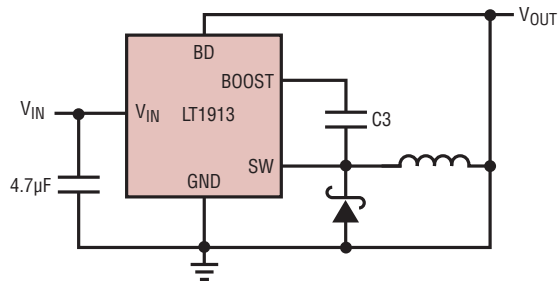
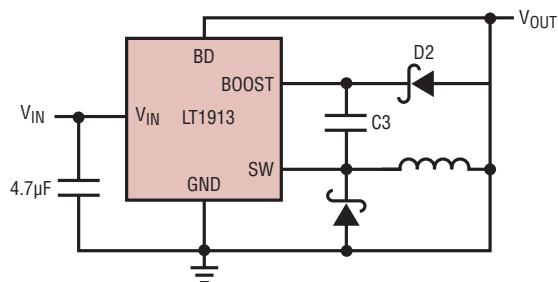

Figure 3. Transient Load Response of the LT1913 Front Page Application as the Load Current is Stepped from 1A to 3A.  $V_{OUT} = 5V$

## APPLICATIONS INFORMATION



(4a) For  $V_{OUT} > 2.8V$



(4b) For  $2.5V < V_{OUT} < 2.8V$

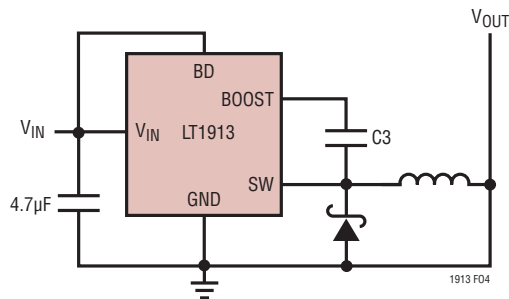

(4c) For  $V_{OUT} < 2.5V$

Figure 4. Three Circuits For Generating The Boost Voltage

more than 2.3V above the SW pin for best efficiency. For outputs of 3V and above, the standard circuit (Figure 4a) is best. For outputs between 2.8V and 3V, use a 1µF boost capacitor. A 2.5V output presents a special case because it is marginally adequate to support the boosted drive stage while using the internal boost diode. For reliable BOOST pin operation with 2.5V outputs use a good external Schottky diode (such as the ON Semi MBR0540), and a 1µF boost capacitor (see Figure 4b). For lower output voltages the boost diode can be tied to the input (Figure 4c), or to another supply greater than 2.8V. The circuit in Figure 4a

is more efficient because the BOOST pin current and BD pin quiescent current comes from a lower voltage source. You must also be sure that the maximum voltage ratings of the BOOST and BD pins are not exceeded.

The minimum operating voltage of an LT1913 application is limited by the minimum input voltage (3.6V) and by the maximum duty cycle as outlined in a previous section. For proper startup, the minimum input voltage is also limited by the boost circuit. If the input voltage is ramped slowly, or the LT1913 is turned on with its RUN/SS pin when the output is already in regulation, then the boost capacitor may not be fully charged. Because the boost capacitor is

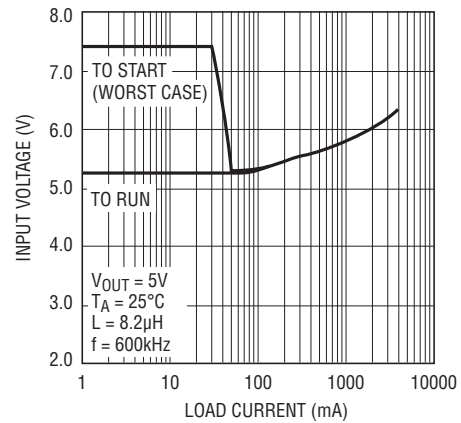
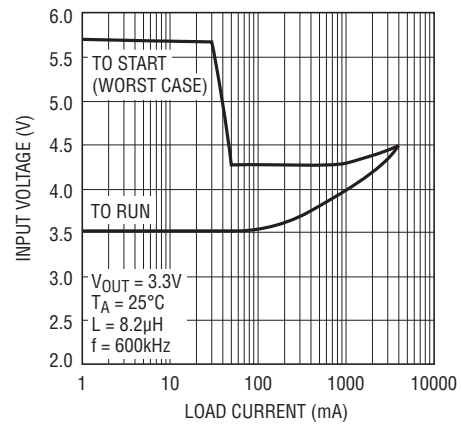

Figure 5. The Minimum Input Voltage Depends on Output Voltage, Load Current and Boost Circuit

## APPLICATIONS INFORMATION

charged with the energy stored in the inductor, the circuit will rely on some minimum load current to get the boost circuit running properly. This minimum load will depend on input and output voltages, and on the arrangement of the boost circuit. The minimum load generally goes to zero once the circuit has started. Figure 5 shows a plot of minimum load to start and to run as a function of input voltage. In many cases the discharged output capacitor will present a load to the switcher, which will allow it to start. The plots show the worst-case situation where  $V_{IN}$  is ramping very slowly. For lower start-up voltage, the boost diode can be tied to  $V_{IN}$ .

At light loads, the inductor current becomes discontinuous and the effective duty cycle can be very high. This reduces the minimum input voltage to approximately 300mV above  $V_{OUT}$ . At higher load currents, the inductor current is continuous and the duty cycle is limited by the maximum duty cycle of the LT1913, requiring a higher input voltage to maintain regulation.

### Soft-Start

The RUN/SS pin can be used to soft-start the LT1913, reducing the maximum input current during start-up. The RUN/SS pin is driven through an external RC filter to create a voltage ramp at this pin. Figure 6 shows the start-up and shut-down waveforms with the soft-start circuit. By choosing a large RC time constant, the peak start-up current can be reduced to the current that is required to regulate the output, with no overshoot. Choose the value of the resistor so that it can supply 20 $\mu$ A when the RUN/SS pin reaches 2.5V.

### Synchronization

Synchronizing the LT1913 oscillator to an external frequency can be done by connecting a square wave (with 20% to 80% duty cycle) to the SYNC pin. The square wave amplitude should have valleys that are below 0.3V and peaks that are above 0.8V (up to 6V).

The LT1913 may be synchronized over a 250kHz to 2MHz range. The  $R_T$  resistor should be chosen to set the LT1913 switching frequency 20% below the lowest synchronization

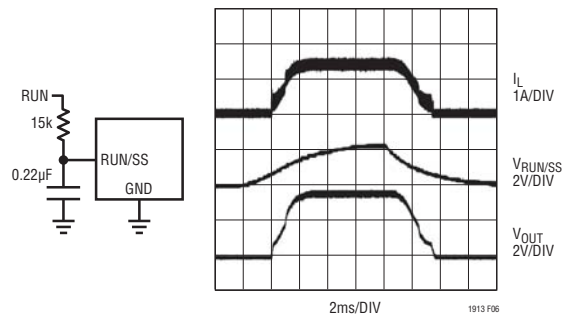

**Figure 6. To Soft-Start the LT1913, Add a Resistor and Capacitor to the RUN/SS Pin**

input. For example, if the synchronization signal will be 250kHz and higher, the  $R_T$  should be chosen for 200kHz. To assure reliable and safe operation the LT1913 will only synchronize when the output voltage is near regulation as indicated by the PG flag. It is therefore necessary to choose a large enough inductor value to supply the required output current at the frequency set by the  $R_T$  resistor. See Inductor Selection section. It is also important to note that slope compensation is set by the  $R_T$  value: When the sync frequency is much higher than the one set by  $R_T$ , the slope compensation will be significantly reduced which may require a larger inductor value to prevent subharmonic oscillation.

### Shorted and Reversed Input Protection

If the inductor is chosen so that it won't saturate excessively, an LT1913 buck regulator will tolerate a shorted output. There is another situation to consider in systems where the output will be held high when the input to the LT1913 is absent. This may occur in battery charging applications or in battery backup systems where a battery or some other supply is diode OR-ed with the LT1913's output. If the  $V_{IN}$  pin is allowed to float and the RUN/SS pin is held high (either by a logic signal or because it is tied to  $V_{IN}$ ), then the LT1913's internal circuitry will pull its quiescent current through its SW pin. This is fine if your system can tolerate a few mA in this state. If you ground the RUN/SS pin, the SW pin current will drop to essentially zero. However, if the  $V_{IN}$  pin is grounded while

## APPLICATIONS INFORMATION

the output is held high, then parasitic diodes inside the LT1913 can pull large currents from the output through the SW pin and the  $V_{IN}$  pin. Figure 7 shows a circuit that will run only when the input voltage is present and that protects against a shorted or reversed input.

### PCB Layout

For proper operation and minimum EMI, care must be taken during printed circuit board layout. Figure 8 shows the recommended component placement with trace, ground plane and via locations. Note that large, switched currents flow in the LT1913's  $V_{IN}$  and SW pins, the catch diode (D1) and the input capacitor (C1). The loop formed by these components should be as small as possible. These components, along with the inductor and output capacitor, should be placed on the same side of the circuit board, and their connections should be made on that layer. Place a local, unbroken ground plane below these components. The SW and BOOST nodes should be as small as possible. Finally, keep the FB and  $V_C$  nodes small so that the ground traces will shield them from the SW and BOOST nodes.

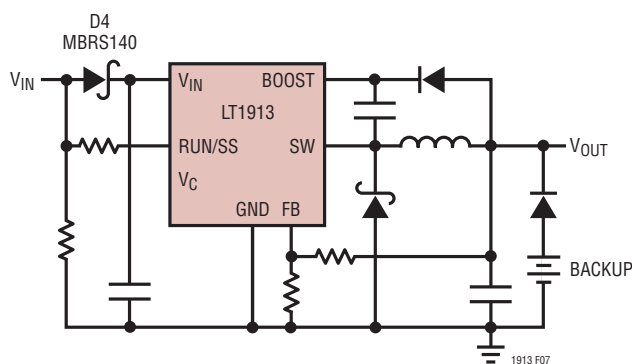
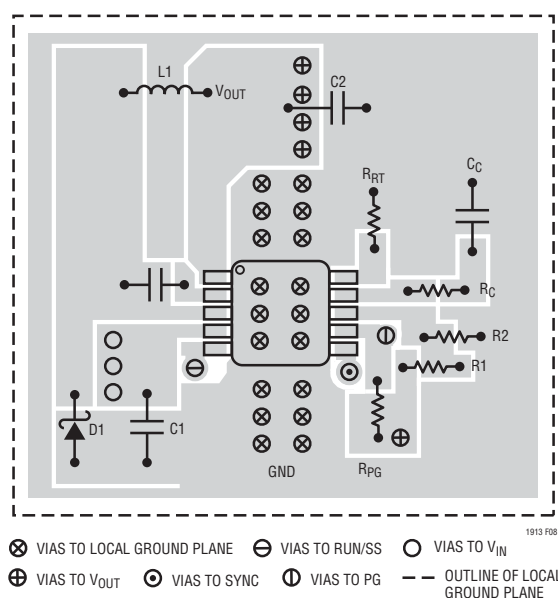

**Figure 7. Diode D4 Prevents a Shorted Input from Discharging a Backup Battery Tied to the Output. It Also Protects the Circuit from a Reversed Input. The LT1913 Runs Only When the Input is Present**

The Exposed Pad on the bottom of the package must be soldered to ground so that the pad acts as a heat sink. To keep thermal resistance low, extend the ground plane as much as possible, and add thermal vias under and near the LT1913 to additional ground planes within the circuit board and on the bottom side.

### Hot Plugging Safely

The small size, robustness and low impedance of ceramic capacitors make them an attractive option for the input bypass capacitor of LT1913 circuits. However, these capacitors can cause problems if the LT1913 is plugged into a live supply (see Linear Technology Application Note 88 for a complete discussion). The low loss ceramic capacitor, combined with stray inductance in series with the power source, forms an under damped tank circuit, and the voltage at the  $V_{IN}$  pin of the LT1913 can ring to twice the nominal input voltage, possibly exceeding the LT1913's rating and damaging the part. If the input supply is poorly controlled or the user will be plugging the LT1913 into an energized supply, the input network should be designed



⊗ VIAS TO LOCAL GROUND PLANE ⊖ VIAS TO RUN/SS ○ VIAS TO  $V_{IN}$   
 ⊕ VIAS TO  $V_{OUT}$  ⊙ VIAS TO SYNC ⊕ VIAS TO PG - - - OUTLINE OF LOCAL GROUND PLANE

**Figure 8. A Good PCB Layout Ensures Proper, Low EMI Operation**

## APPLICATIONS INFORMATION

to prevent this overshoot. Figure 9 shows the waveforms that result when an LT1913 circuit is connected to a 24V supply through six feet of 24-gauge twisted pair. The first plot is the response with a 4.7μF ceramic capacitor at the input. The input voltage rings as high as 50V and the input current peaks at 26A. A good solution is shown in Figure 9b. A 0.7Ω resistor is added in series with the input to eliminate the voltage overshoot (it also reduces the peak input current). A 0.1μF capacitor improves high frequency filtering. For high input voltages its impact on efficiency is minor, reducing efficiency by 1.5 percent for a 5V output at full load operating from 24V.

### High Temperature Considerations

The PCB must provide heat sinking to keep the LT1913 cool. The Exposed Pad on the bottom of the package must be soldered to a ground plane. This ground should be tied to large copper layers below with thermal vias; these layers will spread the heat dissipated by the LT1913. Place additional vias can reduce thermal resistance further. With these steps, the thermal resistance from die (or junction) to ambient can be reduced to  $\theta_{JA} = 35^{\circ}\text{C}/\text{W}$  or less. With 100 LFPM airflow, this resistance can fall by another 25%. Further increases in airflow will lead to lower thermal re-

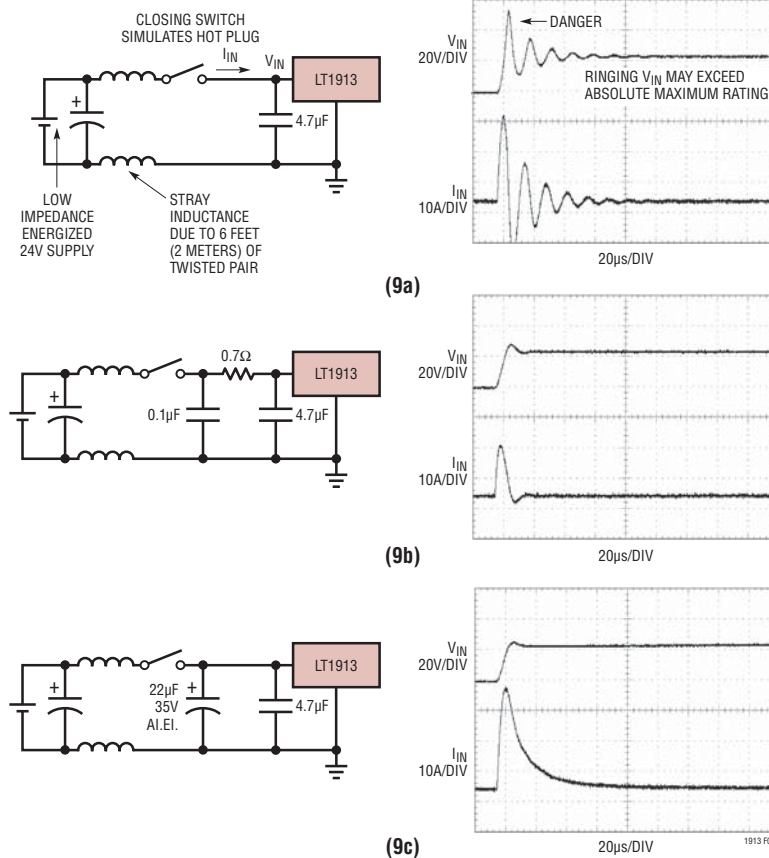

Figure 9. A Well Chosen Input Network Prevents Input Voltage Overshoot and Ensures Reliable Operation when the LT1913 is Connected to a Live Supply

## APPLICATIONS INFORMATION

sistance. Because of the large output current capability of the LT1913, it is possible to dissipate enough heat to raise the junction temperature beyond the absolute maximum of 125°C. When operating at high ambient temperatures, the maximum load current should be derated as the ambient temperature approaches 125°C.

Power dissipation within the LT1913 can be estimated by calculating the total power loss from an efficiency measurement and subtracting the catch diode loss and inductor loss. The die temperature is calculated by multiplying the LT1913 power dissipation by the thermal resistance from junction to ambient.

### Other Linear Technology Publications

Application Notes 19, 35 and 44 contain more detailed descriptions and design information for buck regulators and other switching regulators. The LT1376 data sheet has a more extensive discussion of output ripple, loop compensation and stability testing. Design Note 100 shows how to generate a bipolar output supply using a buck regulator.

## TYPICAL APPLICATIONS

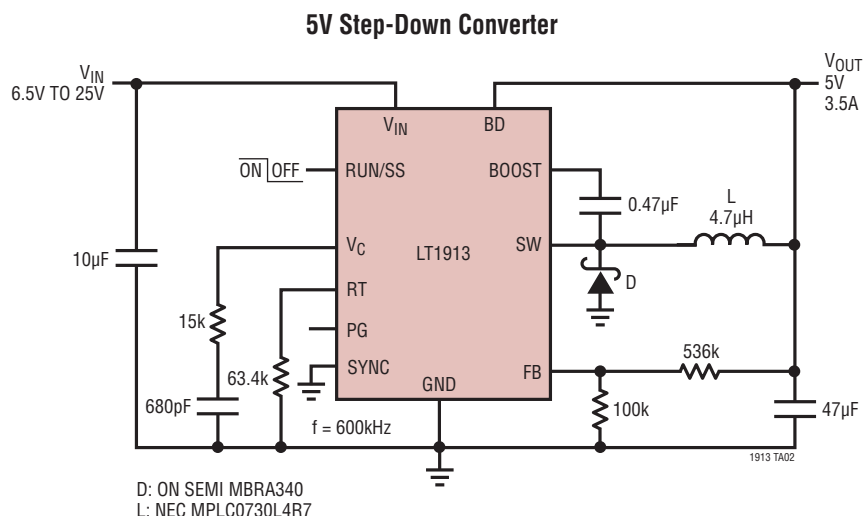

## TYPICAL APPLICATIONS

### 3.3V Step-Down Converter

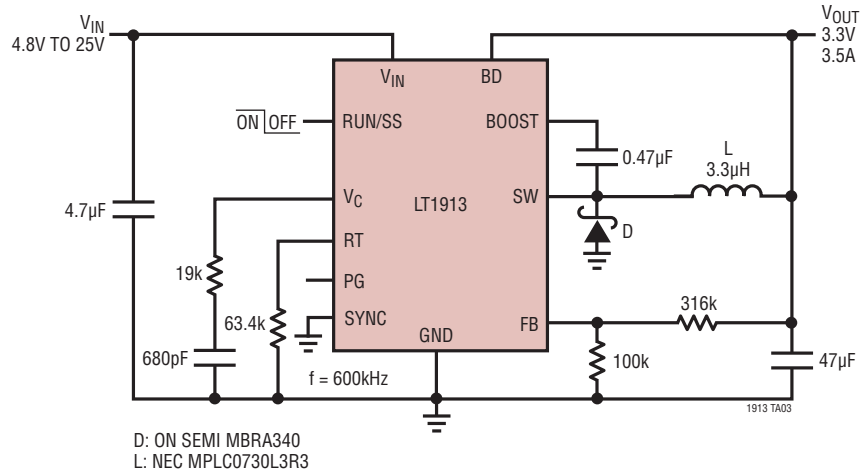

### 2.5V Step-Down Converter

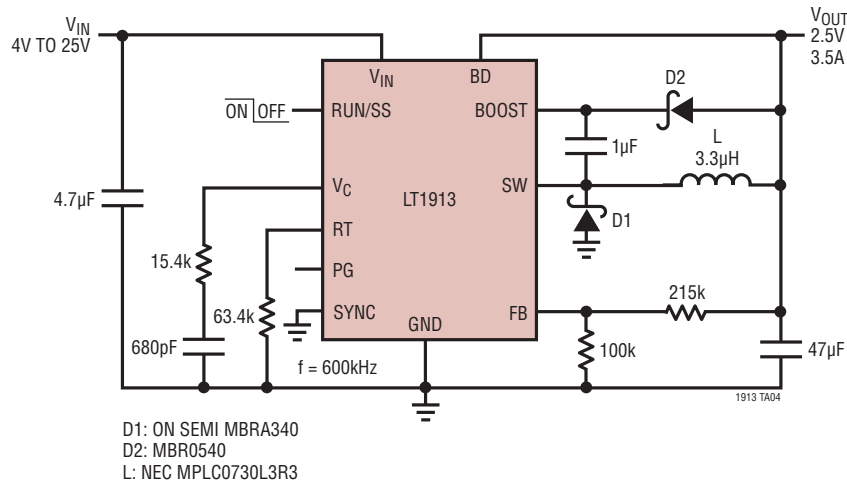

TYPICAL APPLICATIONS

5V, 2MHz Step-Down Converter

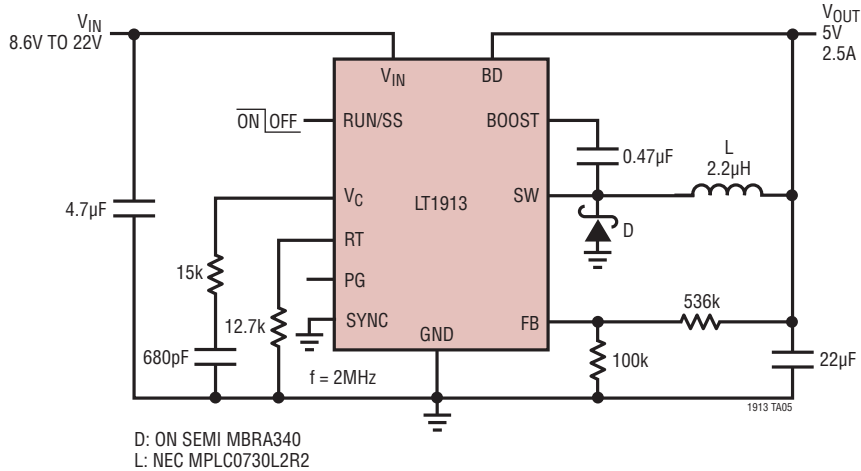

12V Step-Down Converter

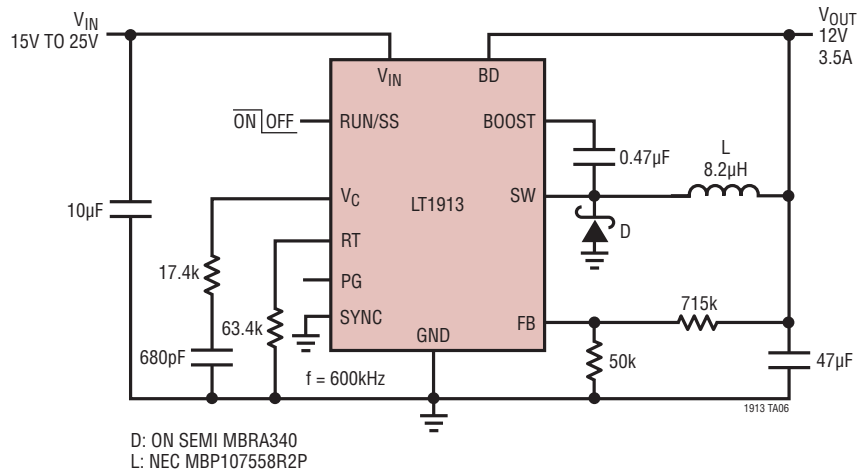

TYPICAL APPLICATIONS

1.8V Step-Down Converter

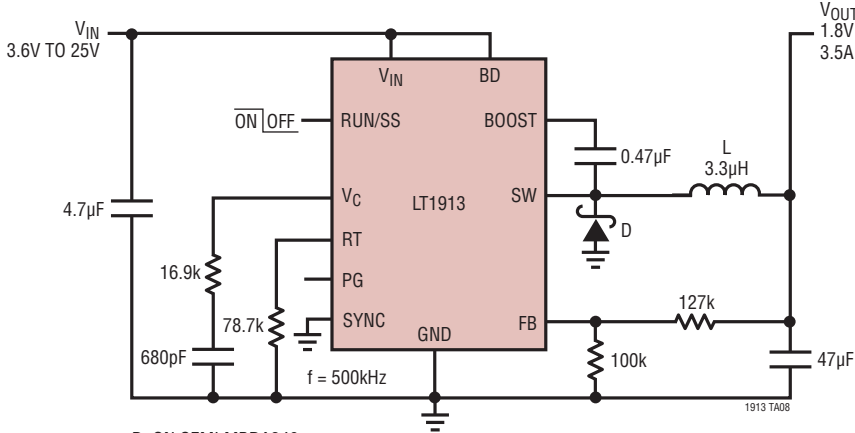

D: ON SEMI MBRA340  
L: NEC MPLC0730L3R3

# PACKAGE DESCRIPTION

**DD Package**  
**10-Lead Plastic DFN (3mm × 3mm)**  
 (Reference LTC DWG # 05-08-1699)

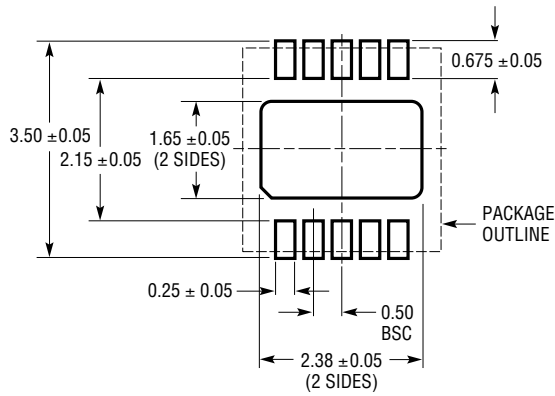

**RECOMMENDED SOLDER PAD PITCH AND DIMENSIONS**

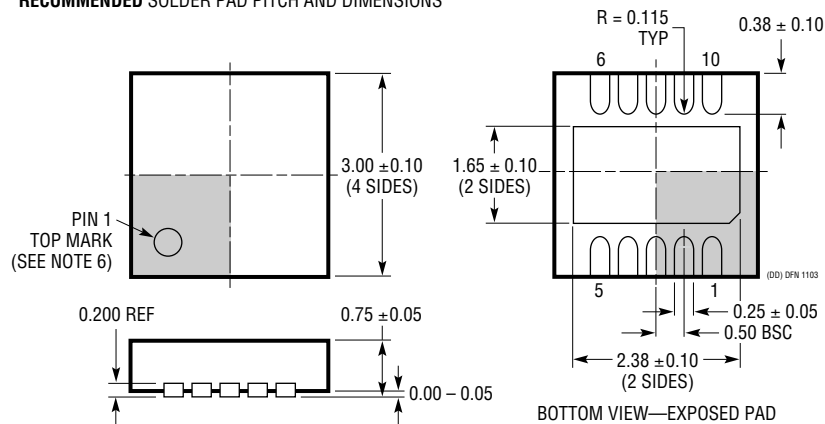

**NOTE:**

1. DRAWING TO BE MADE A JEDEC PACKAGE OUTLINE M0-229 VARIATION OF (WEED-2). CHECK THE LTC WEBSITE DATA SHEET FOR CURRENT STATUS OF VARIATION ASSIGNMENT
2. DRAWING NOT TO SCALE
3. ALL DIMENSIONS ARE IN MILLIMETERS
4. DIMENSIONS OF EXPOSED PAD ON BOTTOM OF PACKAGE DO NOT INCLUDE MOLD FLASH. MOLD FLASH, IF PRESENT, SHALL NOT EXCEED 0.15mm ON ANY SIDE
5. EXPOSED PAD SHALL BE SOLDER PLATED
6. SHADED AREA IS ONLY A REFERENCE FOR PIN 1 LOCATION ON THE TOP AND BOTTOM OF PACKAGE

## TYPICAL APPLICATION

### 1.2V Step-Down Converter

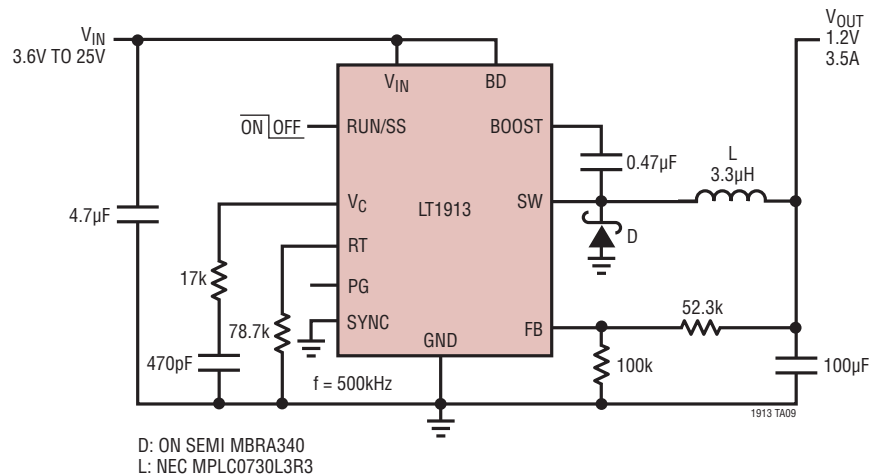

## RELATED PARTS

PART NUMBER	DESCRIPTION	COMMENTS
LT1766	60V, 1.2A ( $I_{OUT}$ ), 200kHz, High Efficiency Step-Down DC/DC Converter	$V_{IN}$ : 5.5V to 60V, $V_{OUT(MIN)}$ = 1.2V, $I_Q$ = 2.5mA, $I_{SD}$ = 25µA, TSSOP16/E Package
LT1933	500mA ( $I_{OUT}$ ), 500kHz Step-Down Switching Regulator in SOT-23	$V_{IN}$ : 3.6V to 36V, $V_{OUT(MIN)}$ = 1.2V, $I_Q$ = 1.6mA, $I_{SD}$ < 1µA, ThinSOT™ Package
LT1936	36V, 1.4A ( $I_{OUT}$ ), 500kHz, High Efficiency Step-Down DC/DC Converter	$V_{IN}$ : 3.6V to 36V, $V_{OUT(MIN)}$ = 1.2V, $I_Q$ = 1.9mA, $I_{SD}$ < 1µA, MS8E Package
LT1940	Dual 25V, 1.4A ( $I_{OUT}$ ), 1.1MHz, High Efficiency Step-Down DC/DC Converter	$V_{IN}$ : 3.6V to 25V, $V_{OUT(MIN)}$ = 1.2V, $I_Q$ = 3.8mA, $I_{SD}$ < 30µA, TSSOP16E Package
LT1976/LT1967	60V, 1.2A ( $I_{OUT}$ ), 200kHz/500kHz, High Efficiency Step-Down DC/DC Converters with Burst Mode Operation	$V_{IN}$ : 3.3V to 60V, $V_{OUT(MIN)}$ = 1.2V, $I_Q$ = 100µA, $I_{SD}$ < 1µA, TSSOP16E Package
LT3434/LT3435	60V, 2.4A ( $I_{OUT}$ ), 200kHz/500kHz, High Efficiency Step-Down DC/DC Converters with Burst Mode Operation	$V_{IN}$ : 3.3V to 60V, $V_{OUT(MIN)}$ = 1.2V, $I_Q$ = 100µA, $I_{SD}$ < 1µA, TSSOP16 Package
LT3437	60V, 400mA ( $I_{OUT}$ ), Micropower Step-Down DC/DC Converter with Burst Mode Operation	$V_{IN}$ : 3.3V to 60V, $V_{OUT(MIN)}$ = 1.25V, $I_Q$ = 100µA, $I_{SD}$ < 1µA, 3mm × 3mm DFN10 and TSSOP16E Packages
LT3480	36V with Transient Protection to 60V, 2A ( $I_{OUT}$ ), 2.4MHz, High Efficiency Step-Down DC/DC Converter with Burst Mode Operation	$V_{IN}$ : 3.6V to 38V, $V_{OUT(MIN)}$ = 0.78V, $I_Q$ = 70µA, $I_{SD}$ < 1µA, 3mm × 3mm DFN10 and MSOP10E Packages
LT3481	34V with Transient Protection to 36V, 2A ( $I_{OUT}$ ), 2.8MHz, High Efficiency Step-Down DC/DC Converter with Burst Mode Operation	$V_{IN}$ : 3.6V to 34V, $V_{OUT(MIN)}$ = 1.26V, $I_Q$ = 50µA, $I_{SD}$ < 1µA, 3mm × 3mm DFN10 and MSOP10E Packages
LT3493	36V, 1.4A ( $I_{OUT}$ ), 750kHz High Efficiency Step-Down DC/DC Converter	$V_{IN}$ : 3.6V to 36V, $V_{OUT(MIN)}$ = 0.8V, $I_Q$ = 1.9mA, $I_{SD}$ < 1µA, 2mm × 3mm DFN6 Package
LT3505	36V with Transient Protection to 40V, 1.4A ( $I_{OUT}$ ), 3MHz, High Efficiency Step-Down DC/DC Converter	$V_{IN}$ : 3.6V to 34V, $V_{OUT(MIN)}$ = 0.78V, $I_Q$ = 2mA, $I_{SD}$ = 2µA, 3mm × 3mm DFN8 and MSOP8E Packages
LT3508	36V with Transient Protection to 40V, Dual 1.4A ( $I_{OUT}$ ), 3MHz, High Efficiency Step-Down DC/DC Converter	$V_{IN}$ : 3.7V to 37V, $V_{OUT(MIN)}$ = 0.8V, $I_Q$ = 4.6mA, $I_{SD}$ = 1µA, 4mm × 4mm QFN24 and TSSOP16E Packages
LT3680	36V, 3.5A ( $I_{OUT}$ ), 2.4MHz High Efficiency Step-Down DC/DC Converter	$V_{IN}$ : 3.6V to 36V, $V_{OUT(MIN)}$ = 0.79V, $I_Q$ = 75µA, $I_{SD}$ < 1µA, 3mm × 3mm DFN, MSOP10E
LT3684	34V with Transient Protection to 36V, 2A ( $I_{OUT}$ ), 2.8MHz, High Efficiency Step-Down DC/DC Converter	$V_{IN}$ : 3.6V to 34V, $V_{OUT(MIN)}$ = 1.26V, $I_Q$ = 850µA, $I_{SD}$ < 1µA, 3mm × 3mm DFN10 and MSOP10E Packages
LT3685	36V with Transient Protection to 60V, Dual 2A ( $I_{OUT}$ ), 2.4MHz, High Efficiency Step-Down DC/DC Converter	$V_{IN}$ : 3.6V to 38V, $V_{OUT(MIN)}$ = 0.78V, $I_Q$ = 70µA, $I_{SD}$ < 1µA, 3mm × 3mm DFN10 and MSOP10E Packages

## Looking for pricing, stock, or lifecycle information?

Click below to explore more details on WIN SOURCE:

 [View LT1913EDD#PBF on WIN SOURCE](#)

 [Linear Technology](#) Information

## Optimize Your Supply Chain with WIN SOURCE Solutions

-  Global Sourcing Solution
-  Obsolete Management
-  Cost Control Management
-  Shortage Management
-  Alternative Solution
-  Excess Inventory Management