



**THE DATASHEET OF  
LT3462ES6#TRMPBF**



# Inverting 1.2MHz/2.7MHz DC/DC Converters with Integrated Schottky

## FEATURES

- **Integrated Schottky Rectifier**
- **Fixed Frequency 1.2MHz/2.7MHz Operation**
- **Very Low Noise: 1mV<sub>P-P</sub> Output Ripple**
- Low  $V_{CESAT}$  Switch: 270mV at 250mA
- -5V at 100mA from 5V Input
- -12V at 30mA from 3.3V Input
- Low Input Bias Current GND Based FB Input
- Low Impedance (40Ω) 1.265V Reference Output
- High Output Voltage: Up to -38V
- Wide Input Range: 2.5V to 16V
- Uses Tiny Surface Mount Components
- Low Shutdown Current: <10μA
- Low Profile (1mm) SOT-23 (ThinSOT™) Package
- 8-Lead DFN (2mm × 2mm × 0.75mm) Package, LT3462A Only

## APPLICATIONS

- CCD Bias
- LCD Bias
- GaAs FET Bias
- General Purpose Negative Voltage Supply

## DESCRIPTION

The **LT<sup>®</sup>3462/LT3462A** are general purpose fixed frequency current mode inverting DC/DC converters. Both devices feature an integrated Schottky and a low  $V_{CESAT}$  switch allowing a small converter footprint and lower parts cost. The LT3462 switches at 1.2MHz while the LT3462A switches at 2.7MHz. These high speeds enable the use of tiny, low cost and low height capacitors and inductors.

The LT3462/LT3462A operate in a dual inductor inverting topology that filters both the input and output currents. Very low output voltage ripple approaching 1mV<sub>P-P</sub> can be achieved when ceramic capacitors are used. Fixed frequency switching ensures a clean output free from low frequency noise typically present with charge pump solutions. The 40V switch allows a  $V_{IN}$  to  $V_{OUT}$  differential of up to 38V for dual inductor topologies.

Both devices provide a low impedance 1.265V reference output to supply the feedback resistor network. A ground referenced, high impedance FB input allows high feedback resistor values without compromising output accuracy.

All registered trademarks and trademarks are the property of their respective owners.

## TYPICAL APPLICATION

5V to -5V, 100mA Inverting DC/DC Converter

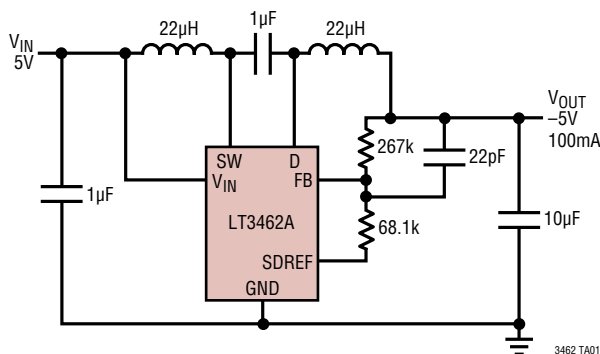

Efficiency

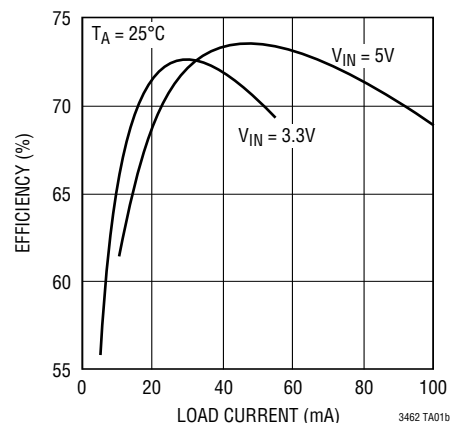

# LT3462/LT3462A

## ABSOLUTE MAXIMUM RATINGS

(Note 1)

Input Voltage ( $V_{IN}$ ).....	16V	Maximum Junction Temperature .....	125°C
SW Voltage .....	40V	Storage Temperature Range .....	-65°C to 150°C
D Voltage .....	-40V	Lead Temperature (Soldering, 10sec)	
SDREF, FB Voltage .....	2.5V	(TSOT-23 Package Only).....	300°C
Operating Ambient			
Temperature Range (Note 3).....	-40°C to 85°C		

## PIN CONFIGURATION

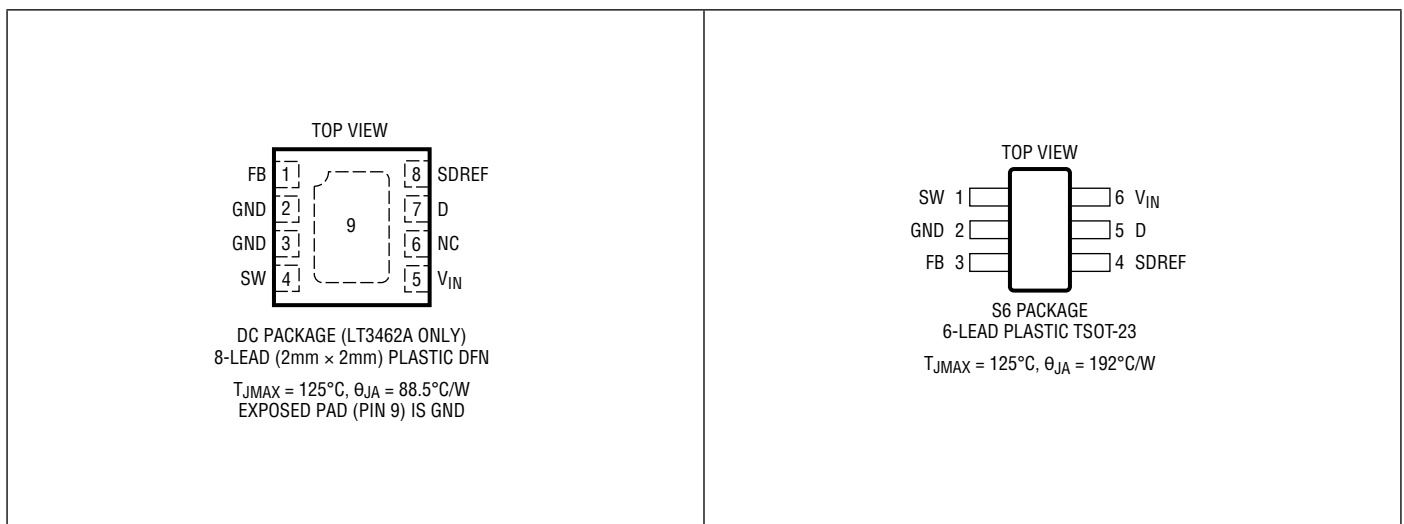

## ORDER INFORMATION

<http://www.linear.com/product/LT3462#orderinfo>

LEAD FREE FINISH	TAPE AND REEL	PART MARKING	PACKAGE DESCRIPTION	TEMPERATURE RANGE
LT3462ES6#PBF	LT3462ES6#TRPBF	LTBBV	6-Lead Plastic TSOT-23	-40°C to 85°C
LT3462AES6#PBF	LT3462AES6#TRPBF	LTBGB	6-Lead Plastic TSOT-23	-40°C to 85°C
LT3462AEDC#PBF	LT3462AEDC#TRPBF	LHGH	8-Lead (2mm × 2mm) Plastic DFN	-40°C to 85°C

Consult ADI Marketing for parts specified with wider operating temperature ranges.

For more information on lead free part marking, go to: <http://www.linear.com/leadfree/>

For more information on tape and reel specifications, go to: <http://www.linear.com/tapeandree/>. Some packages are available in 500 unit reels through designated sales channels with #TRMPBF suffix.

**ELECTRICAL CHARACTERISTICS** The ● denotes the specifications which apply over the full operating temperature range, otherwise specifications are at  $T_A = 25^\circ\text{C}$ ,  $V_{IN} = 3\text{V}$ , unless otherwise noted.

PARAMETER	CONDITIONS		MIN	TYP	MAX	UNITS
Minimum Operating Voltage			2.5			V
Maximum Operating Voltage					16	V
SDREF Voltage	$10\mu\text{A} > I_{SDREF} \geq -80\mu\text{A}$	●	1.245	1.265	1.285	V
FB Pin Bias Current (Note 2)				15	50	nA
SDREF Minus FB Voltage	$10\mu\text{A} > I_{SDREF} \geq -80\mu\text{A}$	●	1.235	1.263	1.285	V
Error Amp Offset Voltage			-12		12	mV
SDREF Reference Source Current	SDREF > 1.2V	●	120	180		$\mu\text{A}$
Supply Current	FB = -0.05V, Not Switching SDREF = 0V, FB = Open, $V_{IN} = 5\text{V}$			2.9 6.5	3.6 10	mA $\mu\text{A}$
SDREF Line Regulation				0.007		%/V
Switching Frequency (LT3462)		●	0.8	1.2	1.6	MHz
Switching Frequency (LT3462A)		●	2.0	2.7	3.5	MHz
Maximum Duty Cycle (LT3462)		●	90			%
Maximum Duty Cycle (LT3462A)		●	77			%
Switch Current Limit			300	420		mA
Switch $V_{CESAT}$	$I_{SW} = 250\text{mA}$			270	350	mV
Switch Leakage Current	$V_{SW} = 5\text{V}$			0.01	1	$\mu\text{A}$
Rectifier Leakage Current	$V_D = -40\text{V}$			0.03	4	$\mu\text{A}$
Rectifier Forward Drop	$I_{SCHOTTKY} = 250\text{mA}$			800	1100	mV
SDREF Voltage Low		●			0.20	V
SDREF Off-State Pull-Up Current			1	2	3	$\mu\text{A}$
SDREF Turn-Off Current			-300	-200		$\mu\text{A}$

**Note 1:** Stresses beyond those listed under Absolute Maximum Ratings may cause permanent damage to the device. Exposure to any Absolute Maximum Rating condition for extended periods may affect device reliability and lifetime.

**Note 2:** Current flows out of the pin.

**Note 3:** The LT3462E is guaranteed to meet specifications from  $0^\circ\text{C}$  to  $70^\circ\text{C}$ . Specifications over the  $-40^\circ\text{C}$  to  $85^\circ\text{C}$  operating temperature range are assured by design, characterization and correlation with statistical process controls.

## TYPICAL PERFORMANCE CHARACTERISTICS

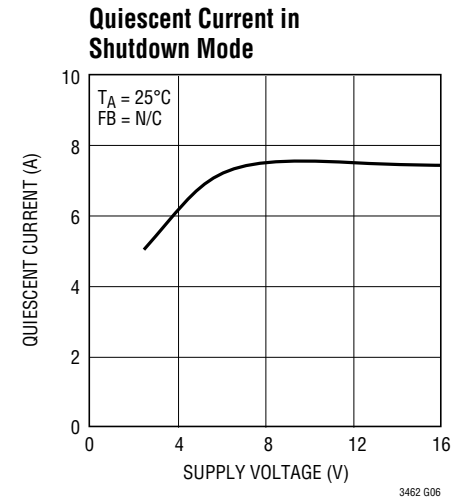
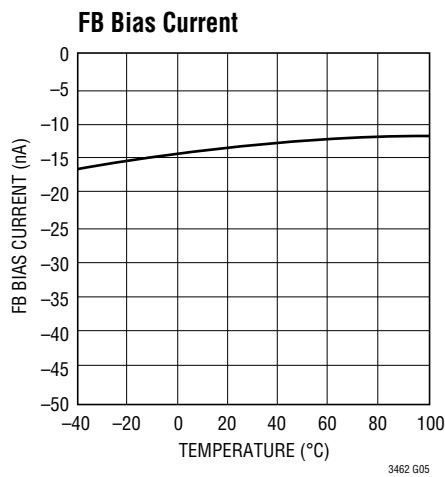
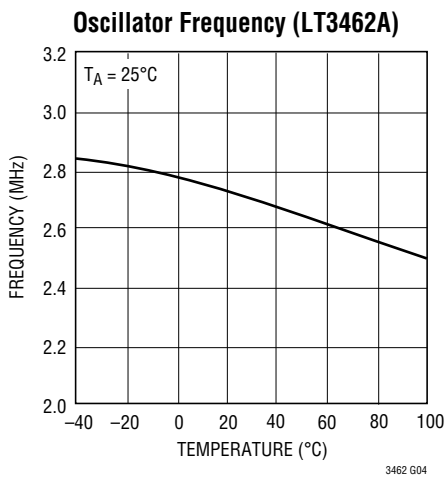
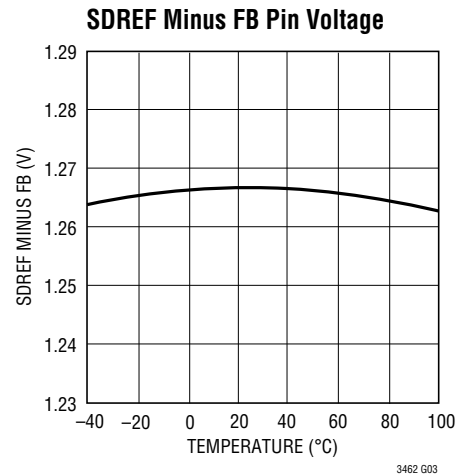
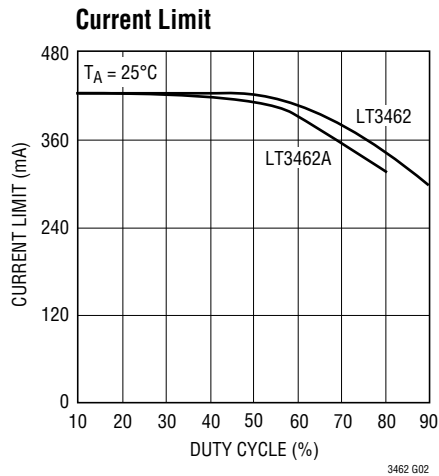
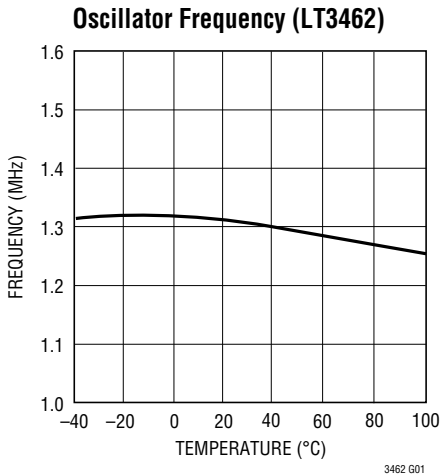

## PIN FUNCTIONS (TSOT-23/DFN)

**SW (Pin 1/Pin 4):** Switch Pin. Connect to external inductor L1 and positive terminal of transfer cap.

**GND (Pin 2/Pins 2, 3):** Ground. Tie directly to local ground plane.

**FB (Pin 3/Pin 1):** Feedback Pin. Connect resistive divider tap here. Set R1 according to  $R1 = R2 \cdot (V_{OUT}/1.265V)$ . In shutdown, a proprietary shutdown bias current cancellation circuit allows the internal  $3\mu A$  source to pull up the SDREF pin, even with residual negative voltage on  $V_{OUT}$ .

**SDREF (Pin 4/Pin 8):** Dual Function Shutdown and 1.265V Reference Output Pin. Pull to GND with external N-FET to turn regulator off. Turn-off pull-down and a  $2\mu A$  internal source will pull SDREF up to turn-on the

regulator. At turn-on, a  $180\mu A$  internal source pulls the pin to the regulation voltage. The SDREF pin can supply up to  $80\mu A$  at 1.265V to bias the feedback resistor divider. An optional soft-start circuit capacitor connects from this pin to  $-V_{OUT}$ .

**D (Pin 5/Pin 7):** Anode Terminal of Integrated Schottky Diode. Connect to negative terminal of transfer cap and external inductor L2.

**$V_{IN}$  (Pin 6/Pin 5):** Input Supply Pin. Must be locally bypassed.

**Exposed Pad (NA/Pin 9):** GND. The exposed pad should be soldered to the PCB ground to achieve the rated thermal performance.

## BLOCK DIAGRAM

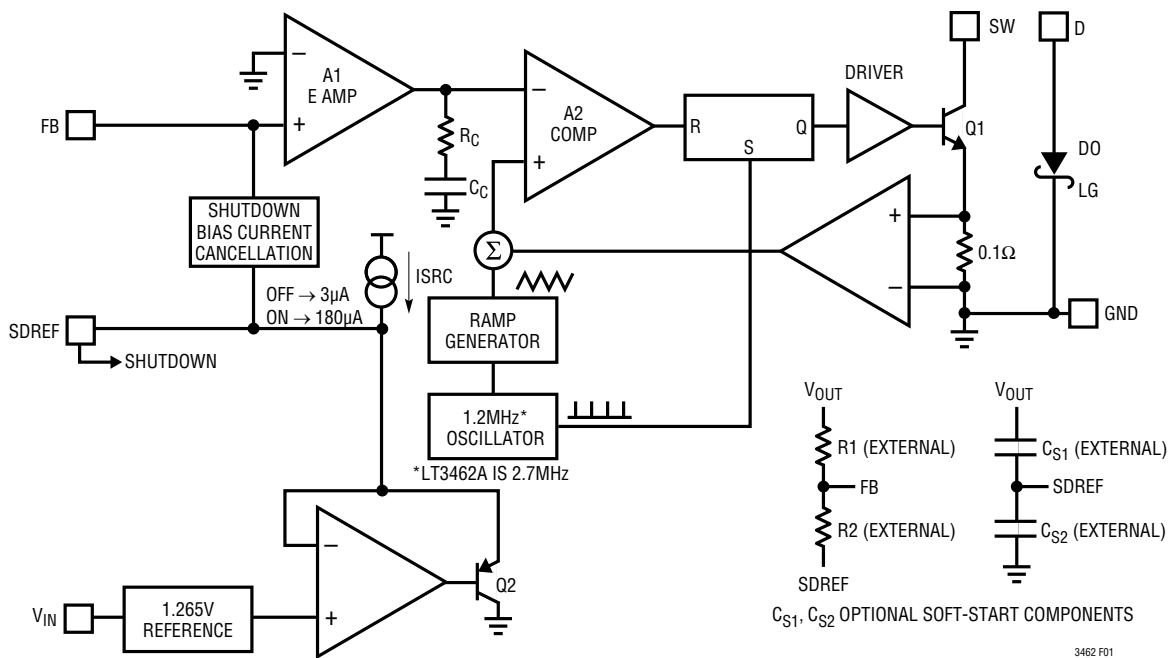

Figure 1. Block Diagram

## OPERATION

The LT3462 uses a constant frequency, current mode control scheme to provide excellent line and load regulation. Operation can be best understood by referring to the Block Diagram in Figure 1. At the start of each oscillator cycle, the SR latch is set, turning on the power switch Q1. A voltage proportional to the switch current is added to a stabilizing ramp and the resulting sum is fed into the positive terminal of the PWM comparator. When this voltage exceeds the voltage at the output of the EAMP, the SR latch is reset, turning off the power switch. The level at the output of the EAMP is simply an amplified version of the difference between the feedback voltage and GND. In this manner, the error amplifier sets the correct peak current level to keep the output in regulation. If the error amplifier's output increases, more current is taken from the output; if it decreases, less current is taken. One function not shown in Figure 1 is the current limit. The switch current is constantly monitored and not allowed to exceed the nominal value of 400mA. If the switch current reaches 400mA, the SR latch is reset regardless of the output state

of the PWM comparator. This current limit cell protects the power switch as well as various external components connected to the LT3462.

SDREF is a dual function input pin. When driven low it shuts the part down, reducing quiescent supply current to less than 10 $\mu$ A. When not driven low, the SDREF pin has an internal pull-up current that turns the regulator on. Once the part is enabled, the SDREF pin sources up to 180 $\mu$ A nominally at a fixed voltage of 1.265V through external resistor R2 to FB. If there is no fault condition present, FB will regulate to 0V, and  $V_{OUT}$  will regulate to  $1.265V \cdot (-R1/R2)$ . An optional soft-start circuit uses the fixed SDREF pull-up current and a capacitor from SDREF to  $V_{OUT}$  to set the dV/dt on  $V_{OUT}$ . In shutdown, an FB bias current cancellation circuit supplies up to 150 $\mu$ A biasing current to external resistor R1 while  $V_{OUT}$  is lower than FB. This function eliminates R2 loading of SDREF during shutdown. As a result, supply current in shutdown may exceed 10 $\mu$ A by the amount of current flowing in R1.

## APPLICATIONS INFORMATION

### Inrush Current

The LT3462 has a built-in Schottky diode. When supply voltage is applied to the  $V_{IN}$  pin, the voltage difference between  $V_{IN}$  and  $V_D$  generates inrush current flowing from input through the inductor and the Schottky diode to charge the flying capacitor to  $V_{IN}$ . The maximum non-repetitive surge current the Schottky diode in the LT3462 can sustain is 1.5A. The selection of inductor and capacitor value should ensure the peak of the inrush current to be below 1.5A. The peak inrush current can be calculated as follows:

$$I_P = \frac{V_{IN} - 0.6}{\sqrt{\frac{L}{C}} - 1} \exp\left(-\frac{\pi}{2\sqrt{\frac{L}{C}} - 1}\right)$$

where L is the inductance between supply and SW, and C is the capacitance between SW and D.

Table 3 gives inrush peak currents for some component selections.

**Table 3. Inrush Peak Current**

$V_{IN}$ (V)	L ( $\mu$ H)	C ( $\mu$ F)	$I_P$ (A)
5	22	1	0.70
5	33	1	0.60
12	47	1	1.40

### Inductor Selection

Each of the two inductors used with LT3462 should have a saturation current rating (where inductance is approximately 70% of zero current inductance) of approximately 0.25A or greater. If the device is used in the charge pump mode, where there is only one inductor, then its rating should be 0.35A or greater. DCR of the inductors should be less than 1 $\Omega$ . For LT3462, a value of 22 $\mu$ H is suitable if using a coupled inductor such as Sumida CLS62-220. If using two separate inductors, increasing the value to 47 $\mu$ H will result in the same ripple current. For LT3462A, a value of 10 $\mu$ H for the coupled inductor and 22 $\mu$ H for two inductors will be acceptable for most applications.

### Capacitor Selection

Ceramic capacitors are recommended. An X7R or X5R dielectric should be used to avoid capacitance decreasing severely with applied voltage and at temperature limits. The “flying” capacitor between the SW and D pins should be a ceramic type of value 1 $\mu$ F or more. When used in the dual inductor or coupled inductor topologies the flying capacitor should have a voltage rating that is more than the difference between the input and output voltages. For the charge pump inverter topology, the voltage rating should be more than the output voltage. The output capacitor should be a ceramic type. Acceptable output capacitance varies from 1 $\mu$ F for high  $V_{OUT}$  (–36V), to 10 $\mu$ F for low  $V_{OUT}$  (–5V). The input capacitor should be a 1 $\mu$ F ceramic type and be placed as close as possible to the LT3462/LT3462A.

### Layout Hints

The high speed operation of the LT3462 demands careful attention to board layout. You will not get advertised performance with careless layout. Figure 2 shows the recommended component placement. A ceramic capacitor of 1 $\mu$ F or more must be placed close to the IC for input supply bypassing.

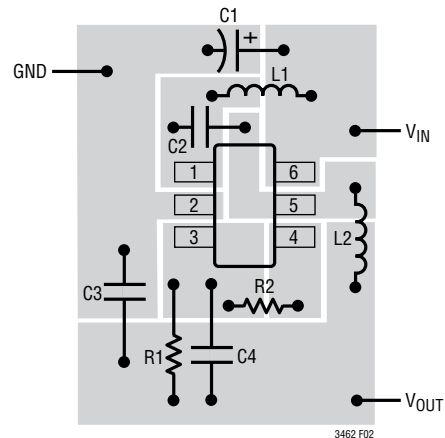

**Figure 2. Suggested Layout**

# TYPICAL APPLICATIONS

## 3.3V to -12V with Soft-Start Circuit

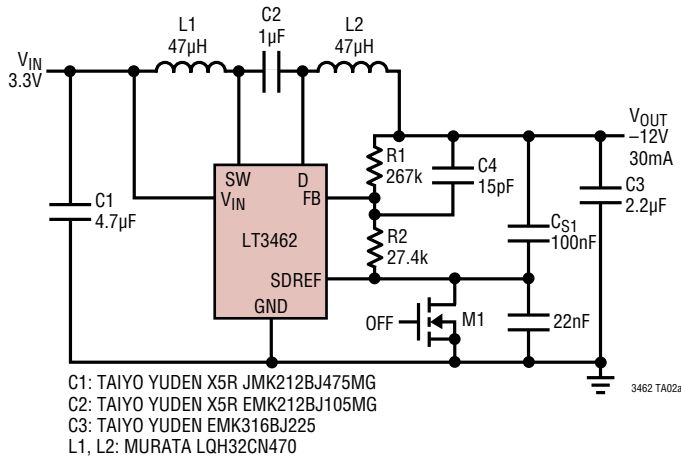

## -12V Efficiency

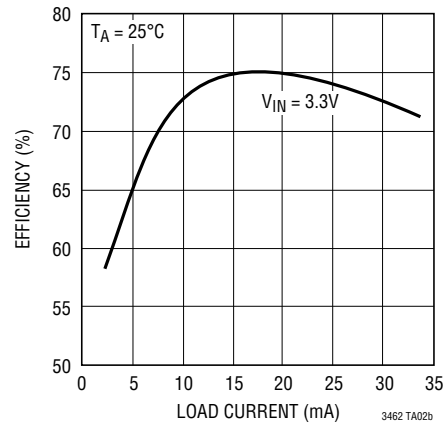

## V<sub>OUT</sub> Reaches -12V in 750µs; Input Current Peaks at 300mA without C<sub>S1</sub>

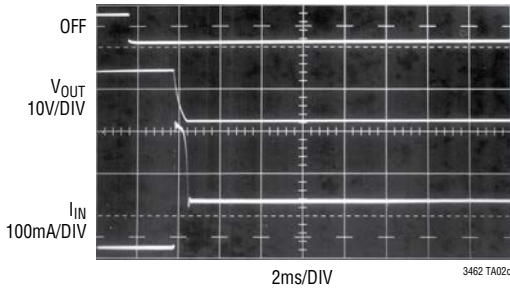

## V<sub>OUT</sub> Reaches -12V in 7.5ms; Input Current Peaks at 125mA with C<sub>S1</sub> = 100nF

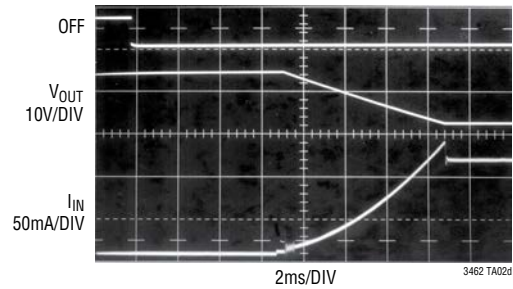

## Li<sup>+</sup> to -8V Supply

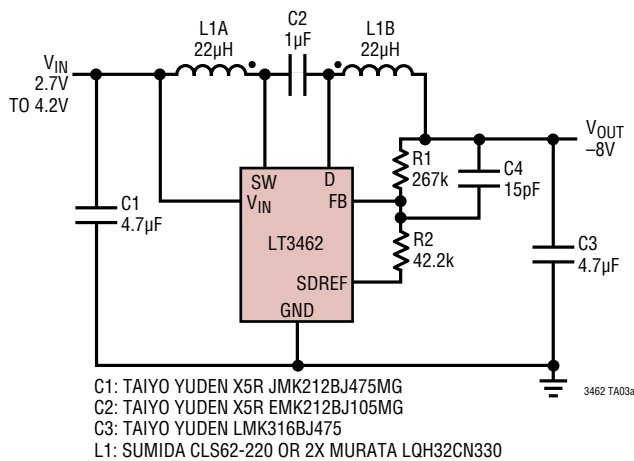

## -8V Efficiency

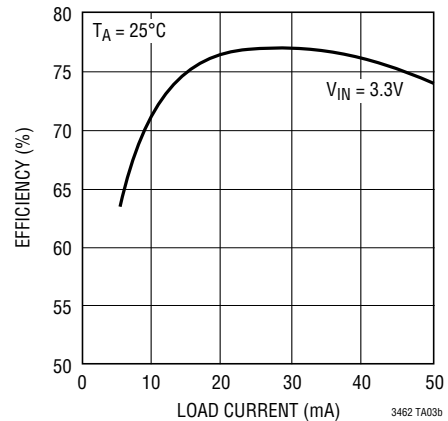

# LT3462/LT3462A

## TYPICAL APPLICATIONS

**3.3V to -8V (LT3462A)**

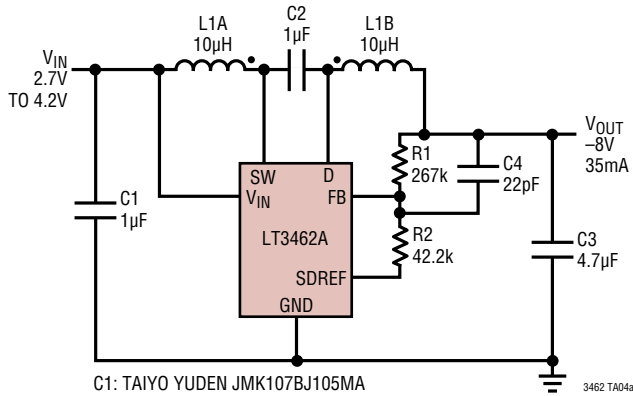

C1: TAIYO YUDEN JMK107BJ105MA  
 C2: TAIYO YUDEN EMK212BJ105MA  
 C3: TAIYO YUDEN LMK316BJ475  
 L1: WURTH 50310057-100

3462 TA04a

**5V to -5V Supply (LT3462A)**

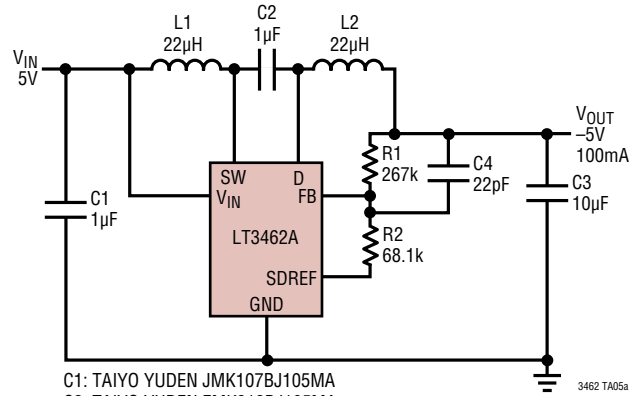

C1: TAIYO YUDEN JMK107BJ105MA  
 C2: TAIYO YUDEN EMK212BJ105MA  
 C3: MURATA GRM219R60J106KE19B  
 L1, L2: MURATA LQH32CN220

3462 TA05a

**Switching Waveform**

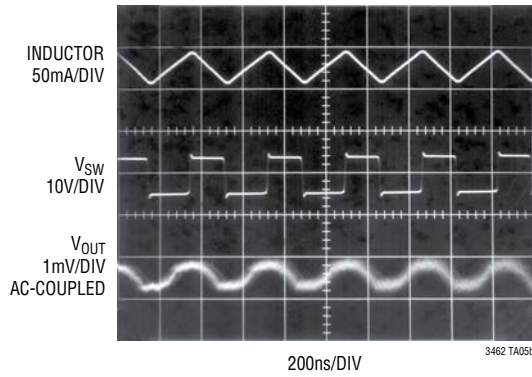

3462 TA05b

# PACKAGE DESCRIPTION

Please refer to <http://www.linear.com/product/LT3462#packaging> for the most recent package drawings.

**DC8 Package**  
**8-Lead Plastic DFN (2mm × 2mm)**  
 (Reference LTC DWG # 05-08-1719 Rev A)

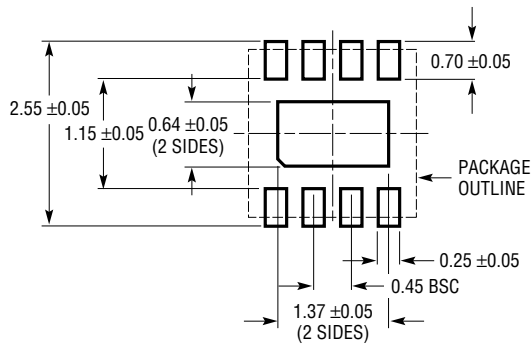

RECOMMENDED SOLDER PAD PITCH AND DIMENSIONS  
 APPLY SOLDER MASK TO AREAS THAT ARE NOT SOLDERED

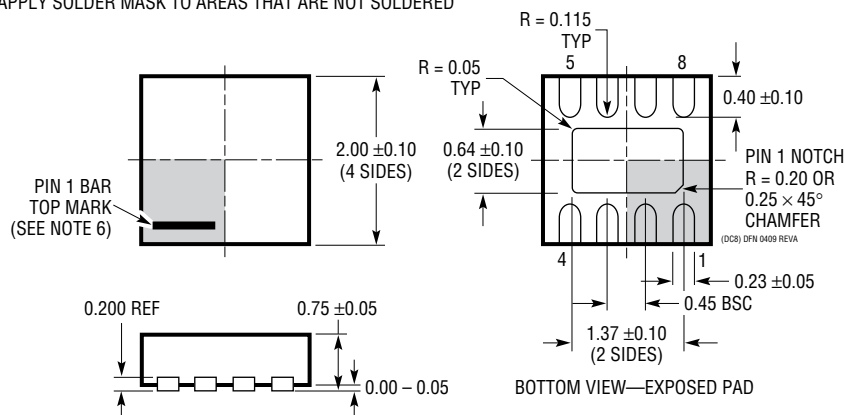

**NOTE:**

1. DRAWING IS NOT A JEDEC PACKAGE OUTLINE
2. DRAWING NOT TO SCALE
3. ALL DIMENSIONS ARE IN MILLIMETERS
4. DIMENSIONS OF EXPOSED PAD ON BOTTOM OF PACKAGE DO NOT INCLUDE MOLD FLASH. MOLD FLASH, IF PRESENT, SHALL NOT EXCEED 0.15mm ON ANY SIDE
5. EXPOSED PAD SHALL BE SOLDER PLATED
6. SHADED AREA IS ONLY A REFERENCE FOR PIN 1 LOCATION ON THE TOP AND BOTTOM OF PACKAGE

## PACKAGE DESCRIPTION

Please refer to <http://www.linear.com/product/LT3462#packaging> for the most recent package drawings.

### S6 Package 6-Lead Plastic TSOT-23 (Reference LTC DWG # 05-08-1636)

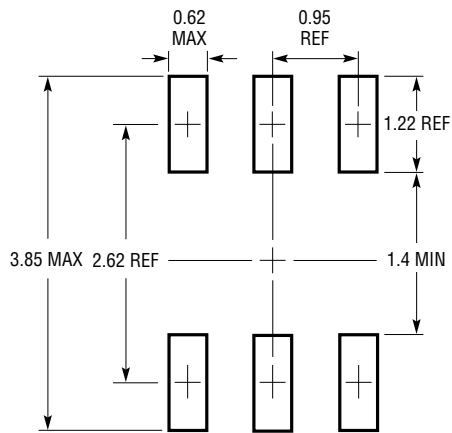

RECOMMENDED SOLDER PAD LAYOUT  
PER IPC CALCULATOR

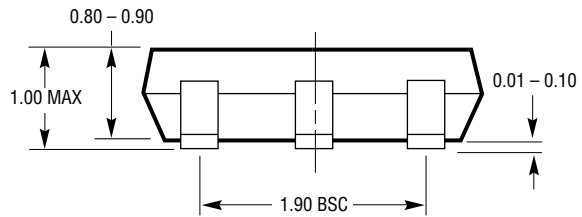
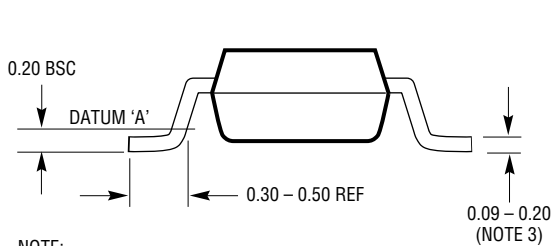
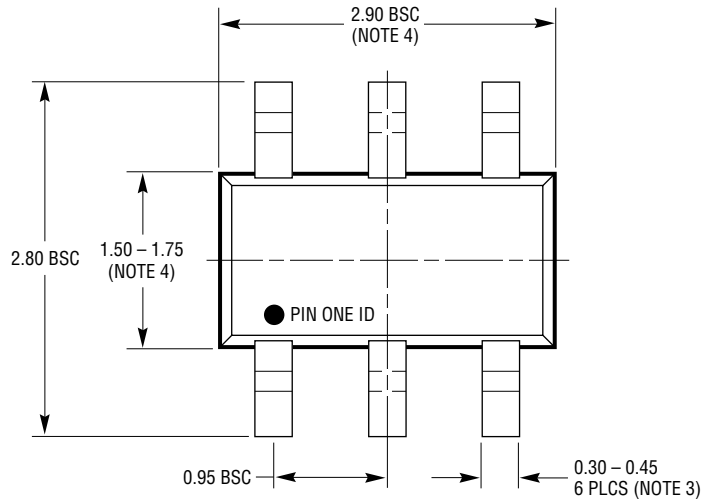

S6 TSOT-23 0302

- NOTE:
1. DIMENSIONS ARE IN MILLIMETERS
  2. DRAWING NOT TO SCALE
  3. DIMENSIONS ARE INCLUSIVE OF PLATING
  4. DIMENSIONS ARE EXCLUSIVE OF MOLD FLASH AND METAL BURR
  5. MOLD FLASH SHALL NOT EXCEED 0.254mm
  6. JEDEC PACKAGE REFERENCE IS MO-193

---

**REVISION HISTORY**

REV	DATE	DESCRIPTION	PAGE NUMBER
A	05/18	Add 2mm × 2mm 8-lead DFN package information (A-grade version only) to data sheet	1, 2, 4, 9

# LT3462/LT3462A

## TYPICAL APPLICATION

12V to -36V DC/DC Converter

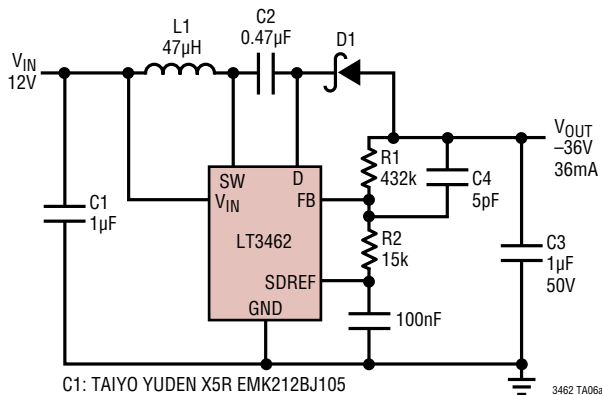

C1: TAIYO YUDEN X5R EMK212BJ105  
 C2: MURATA GRM42-6X7R474K50  
 C3: MURATA GRM42-6X7R474K50 ×2  
 D1: CENTRAL CMSH5-4-LTN  
 L1: MURATA LQH32CN470

3462 TA06a

-36V Efficiency

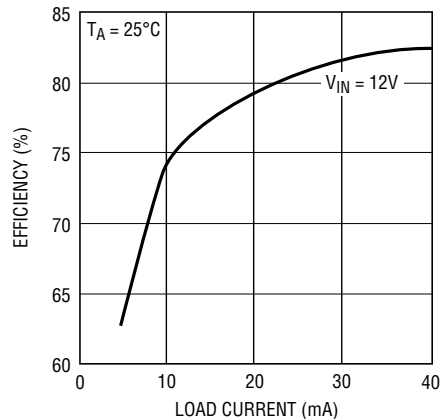

3462 TA06b

## RELATED PARTS

PART NUMBER	DESCRIPTION	COMMENTS
<a href="#">LT1617/LT1617-1</a>	350mA/100mA ( $I_{SW}$ ) High Efficiency Micropower Inverting DC/DC Converter	$V_{IN}$ : 1.2V to 15V, $V_{OUT(MAX)}$ = -34V, $I_Q$ = 20µA, $I_{SD}$ <1µA ThinSOT Package
<a href="#">LT1931/LT1931A</a>	1A ( $I_{SW}$ ), 1.2MHz/2.2MHz, High Efficiency Micropower Inverting DC/DC Converter	$V_{IN}$ : 2.6V to 16V, $V_{OUT(MAX)}$ = -34V, $I_Q$ = 5.8mA, $I_{SD}$ <1µA ThinSOT Package
<a href="#">LT1945</a>	Dual Output, Boost/Inverter, 350mA ( $I_{SW}$ ), Constant Off-Time, High Efficiency Step-Up DC/DC Converter	$V_{IN}$ : 1.2V to 15V, $V_{OUT(MAX)}$ = ±34V, $I_Q$ = 40µA, $I_{SD}$ <1µA, MS10 Package
<a href="#">LT1946/LT1946A</a>	1.5A ( $I_{SW}$ ), 1.2MHz/2.7MHz, High Efficiency Step-Up DC/DC Converter	$V_{IN}$ : 2.45V to 16V, $V_{OUT(MAX)}$ = 34V, $I_Q$ = 3.2mA, $I_{SD}$ <1µA MS8 Package
<a href="#">LT3463</a>	Dual Output, Boost/Inverter, 250mA ( $I_{SW}$ ), Constant Off-Time, High Efficiency Step-Up DC/DC Converter with Integrated Schottky Diodes	$V_{IN}$ : 2.3V to 15V, $V_{OUT(MAX)}$ = ±40V, $I_Q$ = 40µA, $I_{SD}$ <1µA DFN Package
<a href="#">LT3464</a>	85mA ( $I_{SW}$ ), High Efficiency Step-Up DC/DC Converter with Integrated Schottky and PNP Disconnect	$V_{IN}$ : 2.3V to 10V, $V_{OUT(MAX)}$ = 34V, $I_Q$ = 25µA, $I_{SD}$ <1µA ThinSOT Package

Rev A

## Looking for pricing, stock, or lifecycle information?

Click below to explore more details on WIN SOURCE:

- ⊖ [View LT3462ES6#TRMPBF on WIN SOURCE](#)
- ⊖ [Linear Technology Information](#)

## Optimize Your Supply Chain with WIN SOURCE Solutions

- ✓ Global Sourcing Solution
- ✓ Obsolete Management
- ✓ Cost Control Management
- ✓ Shortage Management
- ✓ Alternative Solution
- ✓ Excess Inventory Management