



**THE DATASHEET OF
LT3482EUD#PBF**



90V Boost DC/DC Converter with APD Current Monitor

FEATURES

- **High Output Voltage: Up to 90V**
- **Integrated Schottky Diodes**
- **48V, 280mA Internal Switch**
- **High Side APD Current Monitor**
- Adjustable Switching Frequency: 650kHz or 1.1MHz
- Wide V_{IN} Range: 2.5V to 16V
- Surface Mount Components
- Low Shutdown Current: $<1\mu A$
- Soft-Start
- Internal Compensation
- CTRL Pin Allows Output Adjustment with No Polarity Inversion
- 3mm \times 3mm 16-Lead QFN Package

APPLICATIONS

- APD Bias
- PIN Diode Bias
- Optical Receivers and Modules
- Fiber Optic Network Equipment

DESCRIPTION

The LT[®]3482 is a fixed frequency current mode step-up DC/DC converter with voltage doubler designed to bias avalanche photodiodes (APDs) in optical receivers. It can provide up to 90V output. The LT3482 features high side APD current monitoring with better than 10% relative accuracy over the entire temperature range. The integrated power switch, Schottky diodes and APD current monitor allow a small converter footprint and low solution cost. Constant switching frequency results in predictable output noise that is easy to filter. The inductor-based topology ensures an input free from switching noise. An integrated high side current monitor produces a current proportional to APD current with better than 10% relative accuracy over four decades of dynamic range in the input range of 250nA to 2.5mA. This current can be used as a reference to provide a digitally programmed output voltage via the CTRL pin. The LT3482 is available in the tiny footprint (3mm \times 3mm) 16-lead QFN package.

LT, LT, LTC and LTM are registered trademarks of Linear Technology Corporation. All other trademarks are the property of their respective owners.

TYPICAL APPLICATION

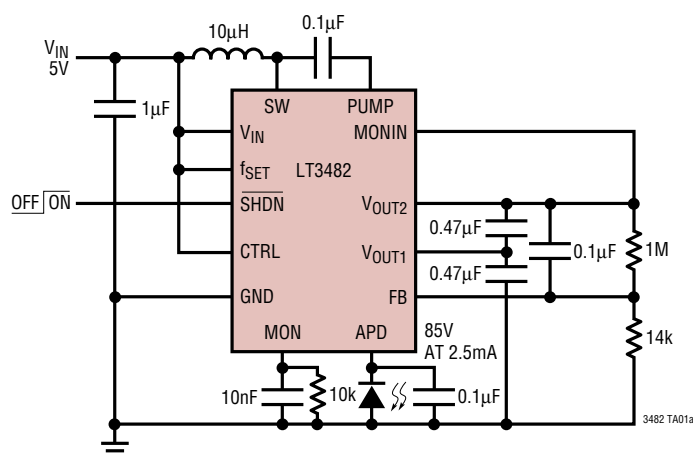

Output Voltage Ripple

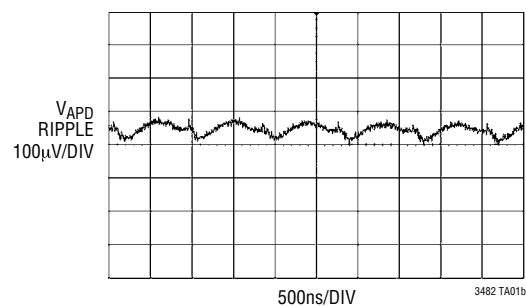

LT3482

ABSOLUTE MAXIMUM RATINGS

(Note 1)

Input Voltage (V_{IN})	16V
V_{OUT1} , SW Voltage	48V
V_{OUT2} , PUMP, MONIN, APD Voltage	90V
FB Voltage	5V
SHDN, f_{SET} , CTRL Voltage	16V
MON Voltage	12V
Operating Temperature Range	
(Note 2)	-40°C to 85°C
Maximum Junction Temperature	125°C
Storage Temperature Range	-65°C to 125°C

PIN CONFIGURATION

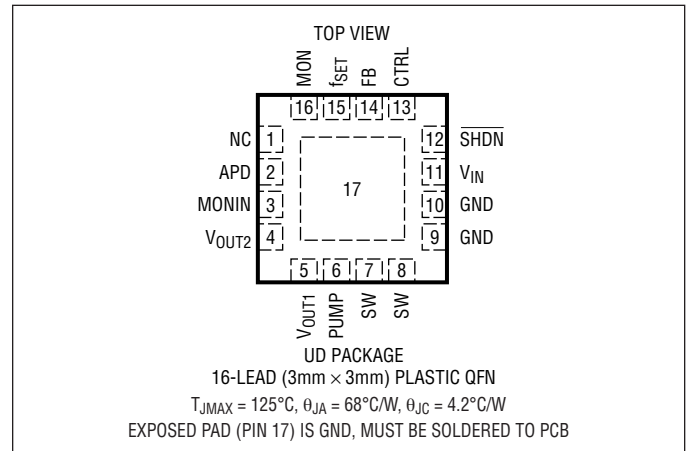

ORDER INFORMATION

LEAD FREE FINISH	TAPE AND REEL	PART MARKING*	PACKAGE DESCRIPTION	TEMPERATURE RANGE
LT3482EUD#PBF	LT3482EUD#TRPBF	LCFG	16-Lead (3mm x 3mm) Plastic QFN	0°C to 85°C
LT3482IUD#PBF	LT3482IUD#TRPBF	LCFG	16-Lead (3mm x 3mm) Plastic QFN	-40°C to 125°C

Consult LTC Marketing for parts specified with wider operating temperature ranges. *The temperature grade is identified by a label on the shipping container.

For more information on lead free parts, go to: <http://www.linear.com/leadfree/>

For more information on tape and reel specifications, go to: <http://www.linear.com/tapeandreeel/>

ELECTRICAL CHARACTERISTICS

The ● denotes the specifications which apply over the full operating temperature range, otherwise specifications are at $T_A = 25^{\circ}\text{C}$. $V_{IN} = 3\text{V}$, $V_{SHDN} = 3\text{V}$ unless otherwise noted.

PARAMETER	CONDITIONS	MIN	TYP	MAX	UNITS
Minimum Operating Voltage		2.5			V
Maximum Operating Voltage				16	V
Feedback Voltage	CTRL = 1.5V	1.215 1.200	1.235	1.255 1.260	V V
Feedback Line Regulation			0.025	0.07	%/V
FB Pin Bias Current			30	100	nA
Supply Current	FB = 1.3V, Not Switching $V_{SHDN} = 0$		3.3 0.1	4.0 0.5	mA μA
Switching Frequency	$f_{SET} = 0\text{V}$ $f_{SET} = 2\text{V}$	580 1.0	650 1.1	750 1.3	kHz MHz
Maximum Duty Cycle	$f_{SET} = 0\text{V}$	95			%
Switch Current Limit		280	360	420	mA
Switch V_{CESAT}	$I_{SW} = 150\text{mA}$		130	220	mV
Switch Leakage Current	SW = 5V			2	μA
Schottky Forward Voltage	$I_{SCHOTTKY} = 150\text{mA}$		880		mV
Schottky Reverse Leakage	$V_{OUT1} - \text{SW} = 50\text{V}$			5	μA
SHDN Voltage High		1.5			V

3482fa

ELECTRICAL CHARACTERISTICS The ● denotes the specifications which apply over the full operating temperature range, otherwise specifications are at $T_A = 25^\circ\text{C}$. $V_{IN} = 3\text{V}$, $V_{SHDN} = 3\text{V}$ unless otherwise noted.

PARAMETER	CONDITIONS		MIN	TYP	MAX	UNITS
SHDN Voltage Low					0.4	V
SHDN Pin Bias Current				35	50	μA
f_{SET} Voltage High			1.5			V
f_{SET} Voltage Low					0.4	V
f_{SET} Bias Current	$f_{SET} = 2\text{V}$			22	40	μA
CTRL to FB Offset	CTRL = 0.5V	●	-5 -10	2 2	10 15	mV mV
APD Current Monitor Gain	$I_{APD} = 250\text{nA}$, $10\text{V} \leq \text{MONIN} \leq 90\text{V}$ $I_{APD} = 2.5\text{mA}$, $20\text{V} \leq \text{MONIN} \leq 90\text{V}$	● ●	0.180 0.185	0.20 0.20	0.215 0.215	
Monitor Output Voltage Clamp				11.5		V
APD Monitor Voltage Drop	MONIN – APD at $I_{APD} = 1\text{mA}$, MONIN = 90V				5	V
MONIN Pin Current Limit	APD = 0V, MONIN = 40V			15		mA

Note 1: Stresses beyond those listed under Absolute Maximum Ratings may cause permanent damage to the device. Exposure to any Absolute Maximum Rating condition for extended periods may affect device reliability and lifetime.

Note 2: The LT3482E is guaranteed to meet specified performance from 0°C to 85°C . Specifications over the -40°C to 85°C operating temperature range are assured by design, characterization and correlation with statistical process controls. The LT3482I is guaranteed to meet performance specifications over the -40°C to 125°C operating temperature range.

TYPICAL PERFORMANCE CHARACTERISTICS ($T_A = 25^\circ\text{C}$ unless otherwise specified)

Oscillator Frequency vs Temperature

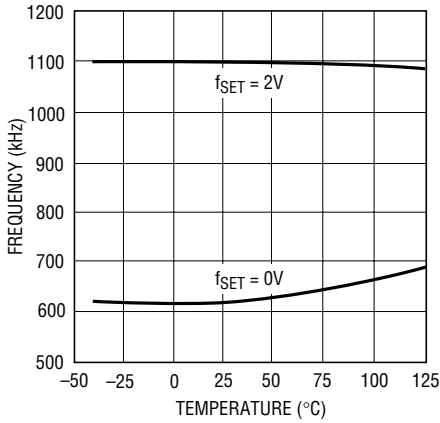

3482 G01

Switch Current Limit vs Duty Cycle

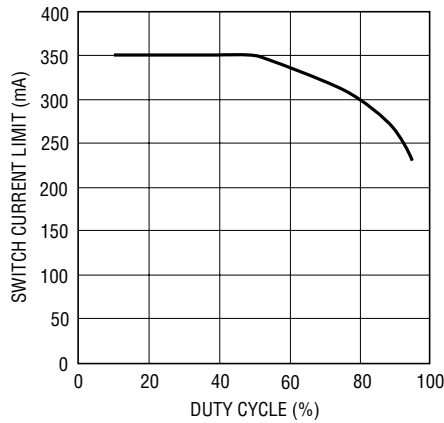

3482 G02

Switch Current Limit vs Temperature

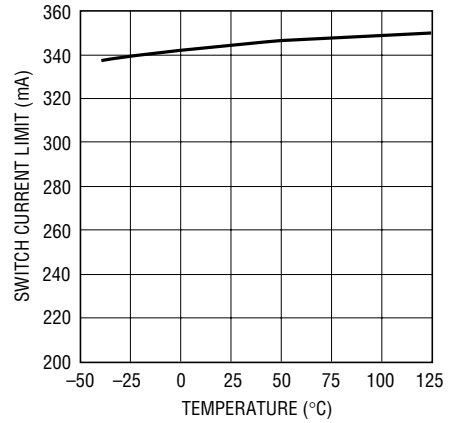

3482 G03

Current Monitor Output vs MONIN

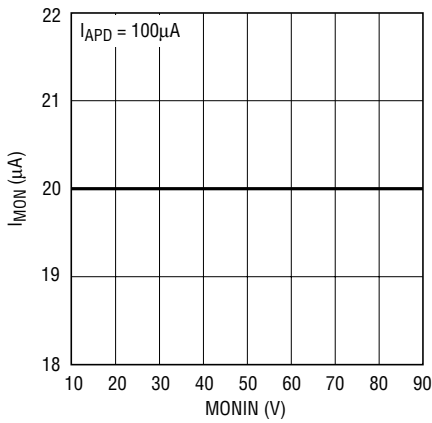

3482 G04

APD Current Monitor Accuracy

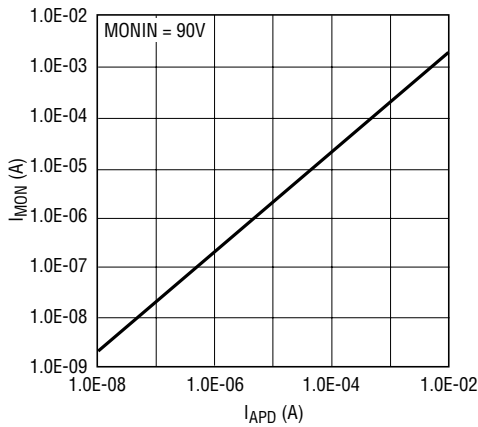

3482 G05

APD Current Monitor Accuracy vs Temperature

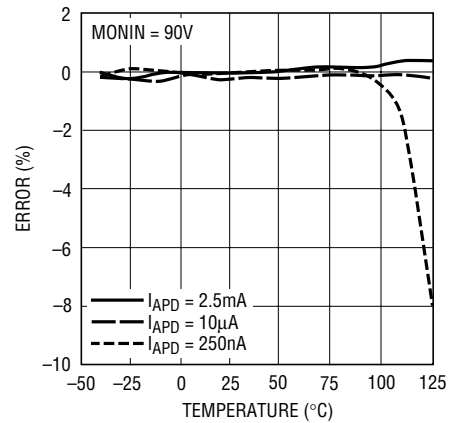

3482 G06

Current Monitor Voltage Drop vs Reference Current

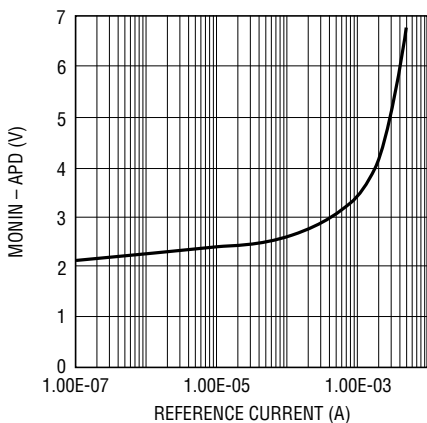

3482 G07

Switch Saturation Voltage (V_{CESAT})

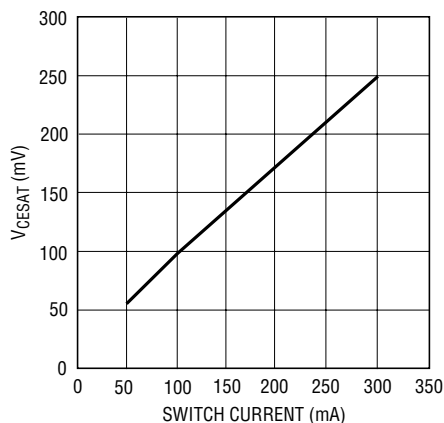

3482 G08

FB Pin Voltage vs Temperature

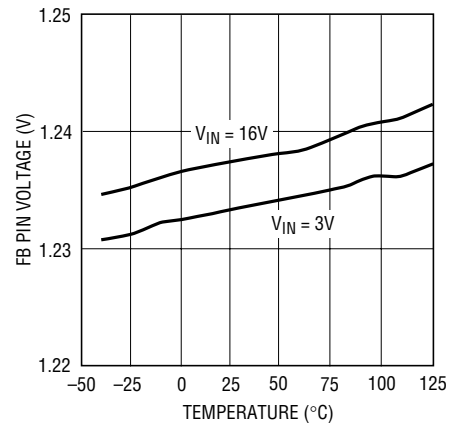

3482 G09

PIN FUNCTIONS

APD (Pin 2): Connect APD cathode to this pin.

MONIN (Pin 3): Current Monitor Power Supply Pin. An external lowpass filter can be included here to further reduce supply voltage ripple.

V_{OUT2} (Pin 4): Voltage Doubler Output Pin. Put a 50V rated capacitor between this pin and V_{OUT1}. Tie a resistor divider to the FB pin and GND.

V_{OUT1} (Pin 5): Boost Output Pin. Put a capacitor between this pin and the GND plane. Minimize the length of the trace to the capacitor.

PUMP (Pin 6): Charge Pump Pin. Put a 50V rating bypass capacitor between SW and PUMP to form a complete voltage doubler with the internal integrated Schottky diodes. Minimize trace length to the capacitor.

SW (Pins 7, 8): Switch Pin. Minimize the trace length on this pin to reduce EMI.

GND (Pins 9, 10): Ground. Pins connected internally. For best performance, connect both pins to board ground.

V_{IN} (Pin 11): Input Supply Pin. This pin must be locally bypassed.

SHDN (Pin 12): Shutdown Pin. Tie to 1.5V or higher to enable device; 0.4V or less to disable device. This pin also functions as soft-start between 1.5V and 2V.

CTRL (Pin 13): Internal Reference Override Pin. This allows the FB voltage to be externally set between 0V and 1.2V. Tie this pin higher than 1.5V to use the internal reference of 1.235V.

FB (Pin 14): Feedback Pin. Connect the output resistor divider tap here.

f_{SET} (Pin 15): Oscillator Frequency Selection Pin. Tie this pin to above 1.5V or higher to select the higher switching frequency of 1.1MHz. For lower switching frequency, tie to GND.

MON (Pin 16): Current Monitor Output Pin. It sources a current equal to 20% of the APD current and converts to a reference voltage through an external resistor.

Exposed Pad (Pin 17): GND. This pin must be soldered to the PCB.

FUNCTIONAL DIAGRAM

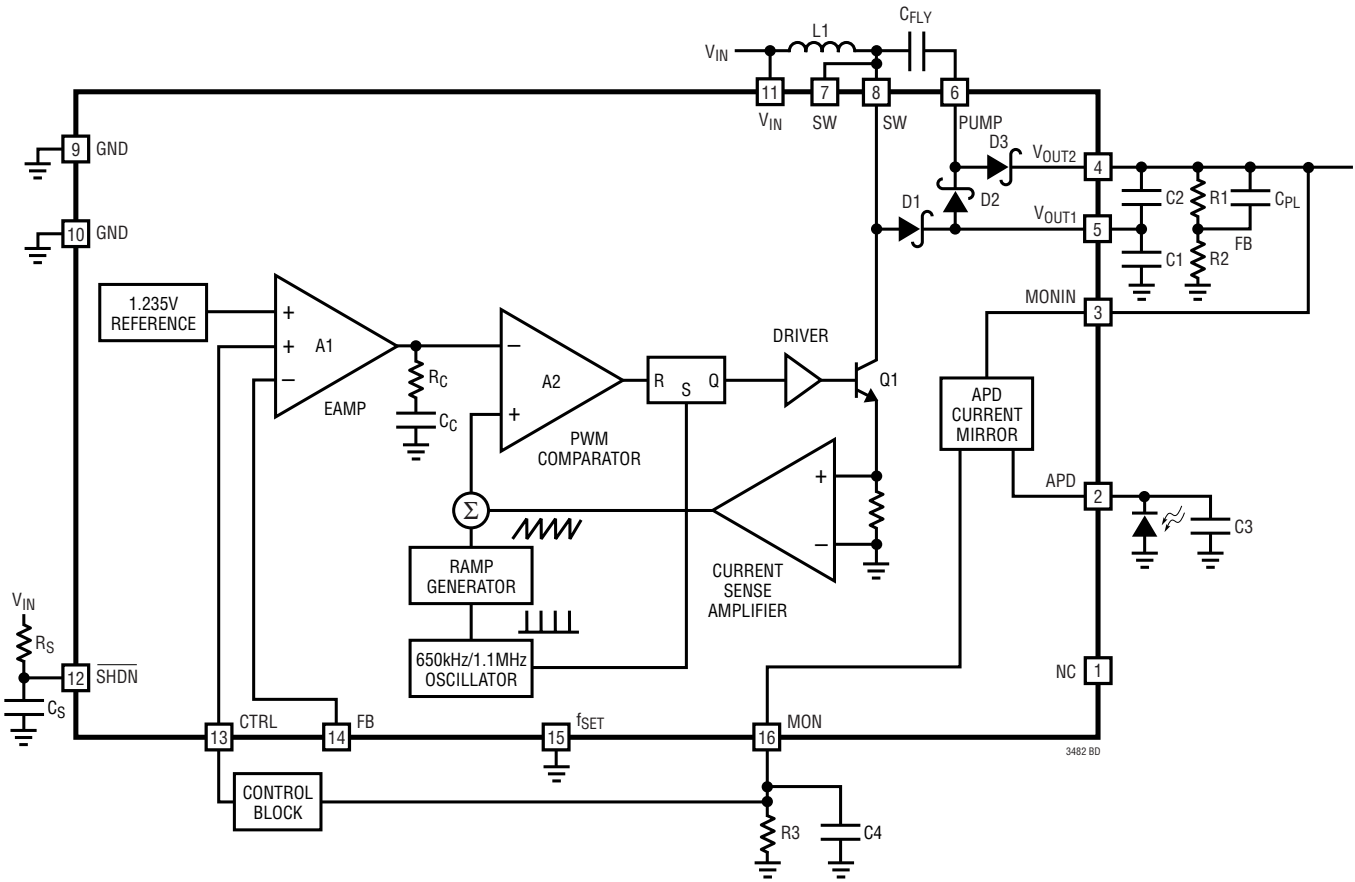

OPERATION

The LT3482 boost converter uses a constant frequency current mode control scheme to provide excellent line and load regulation. Operation can be best understood by referring to the Functional Diagram. At the start of each oscillator cycle, the SR latch is set, which turns on the power switch, Q1. A voltage proportional to the switch current is added to a stabilizing ramp and the resulting sum is fed into the positive terminal of the PWM comparator, A2. When this voltage exceeds the level at the negative input of A2, the SR latch is reset turning off the power switch. The level at the negative input of A2 is set by the error amplifier A1, and is simply an amplified version of the difference between the feedback voltage and the reference voltage of 1.235V, or externally provided CTRL voltage. In this manner, the error amplifier sets the correct peak

current level to keep the output in regulation. If the error amplifier's output increases, more current is delivered to the output; if it decreases, less current is delivered.

The LT3482 has an integrated high side APD current monitor with a 5:1 ratio. The MONIN pin can accept a supply voltage up to 90V, which is suitable for APD photodiode applications. The MON pin has an open-circuit protection feature and is internally clamped to 11.5V.

If an APD is tied to the APD pin, the current will be mirrored to the MON pin and converted to a voltage signal by the resistor R3. This voltage signal can be used to drive an external control block to adjust the APD voltage by adjusting the feedback threshold of EAMP A1 through the CTRL input.

APPLICATIONS INFORMATION

Switching Frequency

The LT3482 can operate at either 650kHz nominal or 1.1MHz nominal; the voltage at the f_{SET} pin selects which frequency is used. At 1.1MHz, a physically smaller inductor and capacitor can be used in a given application, but higher frequencies will slightly decrease efficiency and maximum duty cycle. Generally if efficiency and maximum duty cycle are crucial, the lower switching frequency should be selected by connecting f_{SET} to GND. If application size and cost are more important, connect f_{SET} to V_{IN} to select the higher switching frequency.

Inrush Current

The LT3482 has built-in Schottky diodes for the boost and charge pump. When supply voltage is applied to the V_{IN} pin, the voltage difference between V_{IN} and V_{OUT1} generates inrush current flowing from input through the inductor and the Schottky diode (D1 in the Functional Diagram) to charge the output capacitor. The selection of inductor and capacitor value should ensure the peak of the inrush current to be below 1A. In addition, the LT3482 turn-on should be delayed until the inrush current is less than the maximum current limit. The peak inrush current can be estimated as follows:

$$I_P = \frac{V_{IN} - 0.6}{\sqrt{\frac{L}{C}} - 1} \cdot \exp\left(-\frac{\pi}{2\sqrt{\frac{L}{C}} - 1}\right)$$

where L is the inductance and C is the output capacitance. Table 1 gives inrush peak currents for some component selections.

Table 1. Inrush Peak Current

V_{IN} (V)	L (μ H)	C (μ F)	I_P (A)
5	10	1	0.87
5	22	1	0.68

Setting Output Voltage

The LT3482 is equipped with both an internal 1.235V reference and an auxiliary reference input (the CTRL pin). This allows users to select between using the built-in reference and supplying an external reference voltage. The voltage at the CTRL pin can be adjusted while the chip is operating to alter the output voltage of LT3482 for purposes such as APD's bias voltage adjustment. To use the internal 1.235V reference, the CTRL pin should be held higher than 1.5V, which can be done by tying it to V_{IN} . When the CTRL pin is between 0V and 1.2V, the LT3482 will regulate the output such that the FB pin voltage is equal to the CTRL pin voltage.

To set the output voltage, select the values of R1 and R2 (see Figure 1) according to the following equation:

$$R1 = R2 \left(\frac{V_{OUT2} - 1}{V_{REF}} \right)$$

where $V_{REF} = 1.235V$ if the internal reference is used or $V_{REF} = CTRL$ if CTRL is between 0V and 1.2V. R2 can be selected to load the output to maintain a constant switching frequency when the APD load is very low. Preventing entry into pulse skipping mode is an important consideration for post filtering the regulator output.

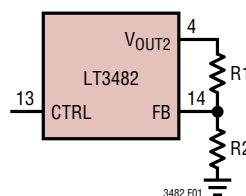

Figure 1. Output Voltage Feedback Connection

APPLICATIONS INFORMATION

Inductor Selection

The inductors used with the LT3482 should have a saturation current rating of 0.3A or greater. If the device is used in an application where the input supply will be hot-plugged, the saturation current rating should be equal to or greater than the peak inrush current. For best loop stability, the inductor value selected should provide a ripple current of 60mA or more. For a given V_{IN} and V_{OUT1} , the inductor value to use in continuous conduction mode (CCM) is estimated by the formula:

$$L = \frac{D \cdot V_{IN}}{f \cdot 60\text{mA}}$$

where:

$$D = \frac{V_{OUT1} + 1 - V_{IN}}{V_{OUT1} + 1}$$

and f is the switching frequency.

To achieve low output voltage ripple, a small value inductor should be selected to force the LT3482 work in discontinuous conduction mode (DCM). The inequality is true when the LT3482 is operating in discontinuous condition mode.

$$L < \frac{D \cdot V_{IN}}{f \cdot I_{LIMIT}}$$

where I_{LIMIT} is the switch current limit. Operating in DCM reduces the maximum load current and the conversion efficiency.

Capacitor Selection

Low ESR capacitors should be used at the output to minimize the output voltage ripple. Use only X5R and X7R types because they retain their capacitance over wider voltage and temperature ranges than other types. High output voltages typically require less capacitance for loop stability. For applications with out voltage less than 45V, intermediate output pin V_{OUT1} can directly serve as the output pin. Typically use a 2 μ F capacitor for output voltage less than 25V and 1 μ F capacitor for output voltage between 25V and 45V. When output voltage goes beyond 45V, a charge pump must be formed with cascaded 0.47 μ F

capacitors C1 and C2 at the output nodes. A typical 0.1 μ F capacitor is used as the flying capacitor C_{FLY} to form the charge pump. Always use a capacitor with sufficient voltage rating.

Either ceramic or solid tantalum capacitors may be used for the input decoupling capacitor, which should be placed as close as possible to the LT3482. A 1 μ F capacitor is sufficient for most applications.

Phase Lead Capacitor

A small value capacitor (i.e., 10pF to 22pF) can be added in parallel with the resistor between the output and the FB pin to reduce output perturbation due to a load step and to improve transient response. This phase lead capacitor introduces a pole-zero pair to the feedback that boosts phase margin near the crossover frequency.

The APD is very sensitive to a noisy bias supply. To lowpass filter noise from the internal reference and error amplifier, a 0.1 μ F phase lead capacitor can be used. The corner frequency of the noise filter is $R1 \cdot C_{PL}$.

APD Current Monitor

The power supply switching noise associated with a switching power supply can interfere with the photodiode DC measurement. To suppress this noise, a 0.1 μ F capacitor is recommended at APD pin. An additional output lowpass filter, a 10k resistor and a 10nF capacitor in parallel at MON pin, can further reduce the power supply noise and other wide band noise, which might limit the measurement accuracy of low level signals. For applications requiring fast current monitor response time, a RC lowpass filter at MONIN pin is used to replace the 0.1 μ F capacitor at APD pin, as illustrated in Figure 2.

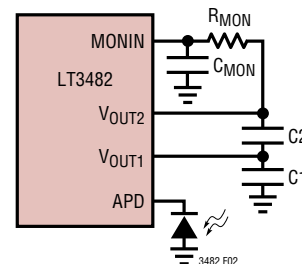

Figure 2

APPLICATIONS INFORMATION

In some applications, a long cable or wire is used to connect the LT3482 to APD. When APD is shorted to GND, APD pin voltage might ring below ground and damage the internal circuitry. To prevent damage during short-circuit event, a 20Ω resistor must be added in series with the APD.

Layout Hints

The high speed operation of the LT3482 demands careful attention to board layout. You will not get advertised performance with careless layout. Figure 3 shows the recommended component placement.

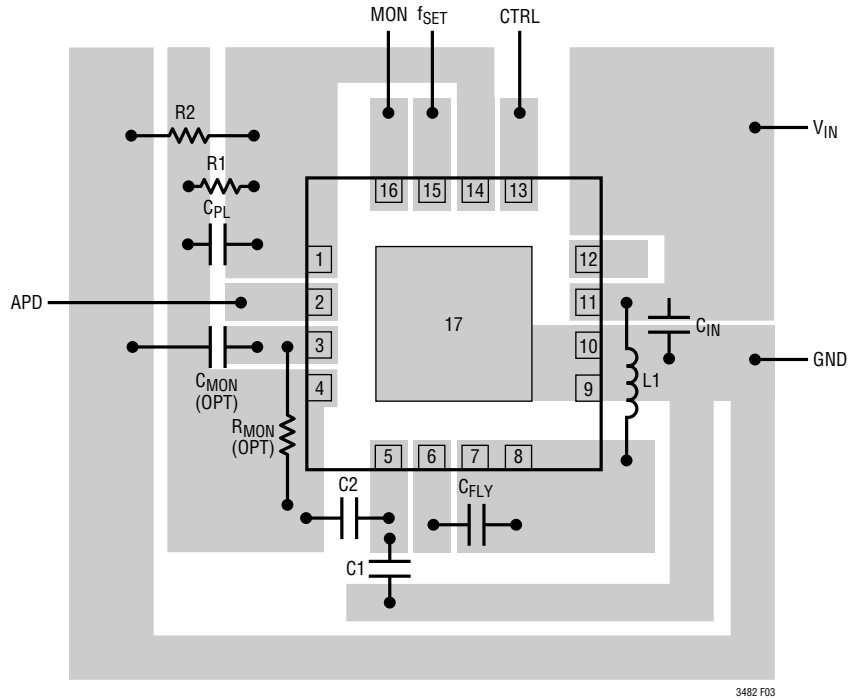
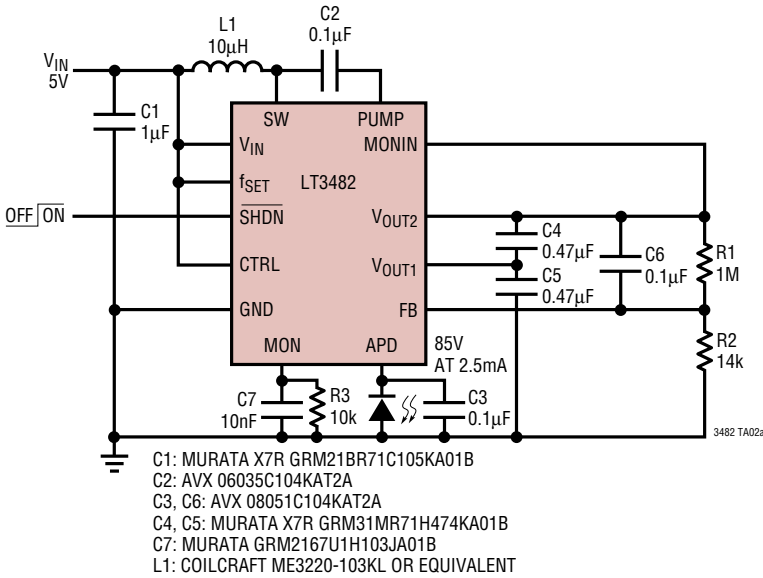

Figure 3. Suggested Layout

TYPICAL APPLICATIONS

5V to 85V APD Bias Power Supply



Efficiency

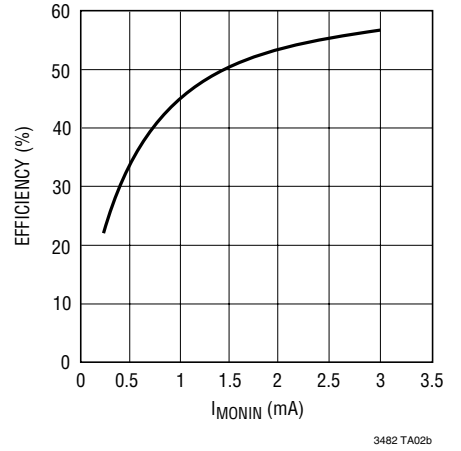

3.3V to 70V APD Bias Power Supply with Fast Current Monitor Response

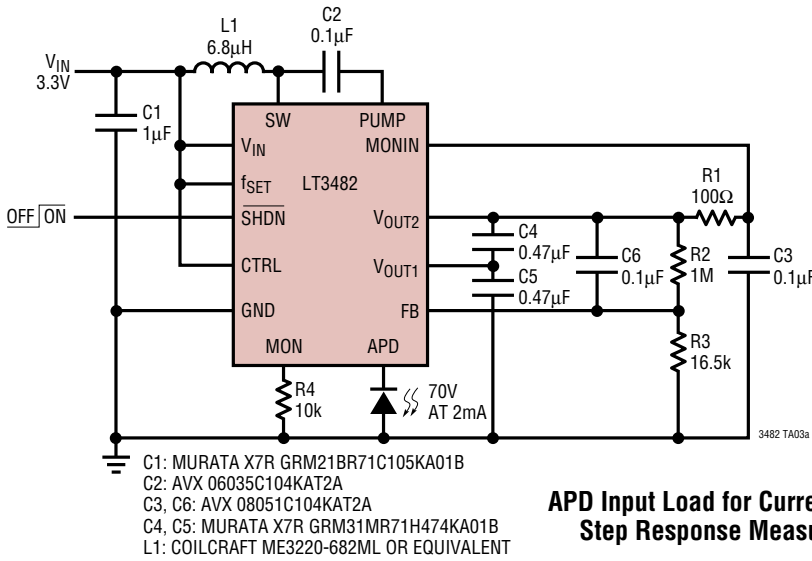

Efficiency

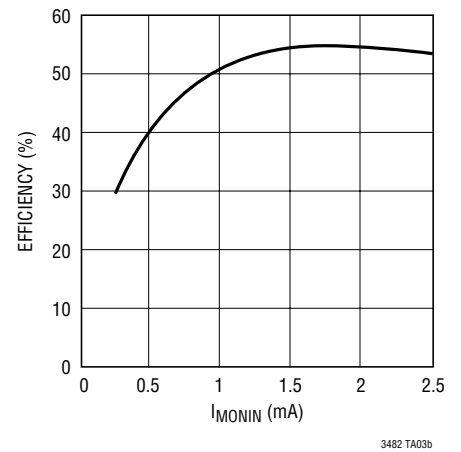

APD Input Load for Current Monitor Step Response Measurement

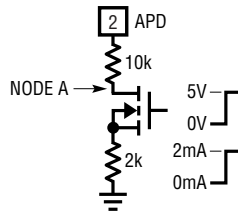

Current Monitor Step Response

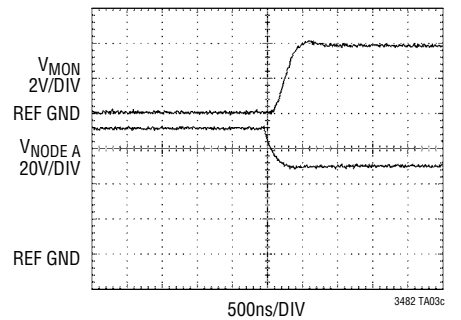

PACKAGE DESCRIPTION

UD Package
16-Lead Plastic QFN (3mm × 3mm)
 (Reference LTC DWG # 05-08-1691)

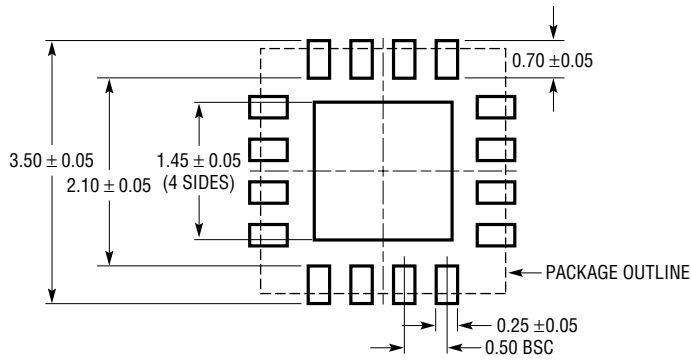

RECOMMENDED SOLDER PAD PITCH AND DIMENSIONS

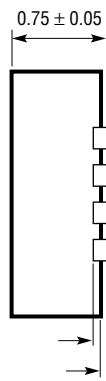
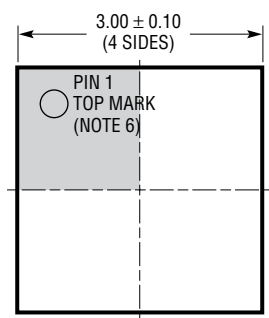

BOTTOM VIEW—EXPOSED PAD

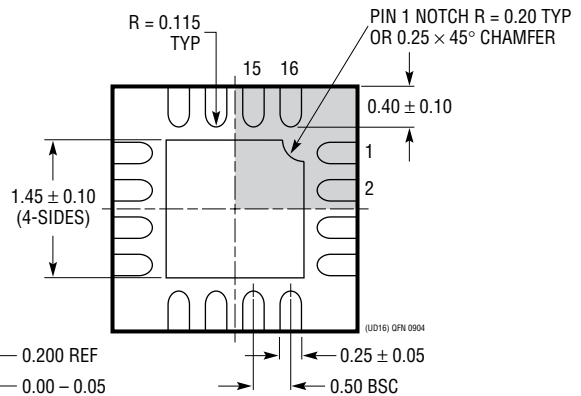

NOTE:

1. DRAWING CONFORMS TO JEDEC PACKAGE OUTLINE MO-220 VARIATION (WEED-2)
2. DRAWING NOT TO SCALE
3. ALL DIMENSIONS ARE IN MILLIMETERS
4. DIMENSIONS OF EXPOSED PAD ON BOTTOM OF PACKAGE DO NOT INCLUDE MOLD FLASH. MOLD FLASH, IF PRESENT, SHALL NOT EXCEED 0.15mm ON ANY SIDE
5. EXPOSED PAD SHALL BE SOLDER PLATED
6. SHADED AREA IS ONLY A REFERENCE FOR PIN 1 LOCATION ON THE TOP AND BOTTOM OF PACKAGE

TYPICAL APPLICATION

3.3V to 40V APD Bias Power Supply

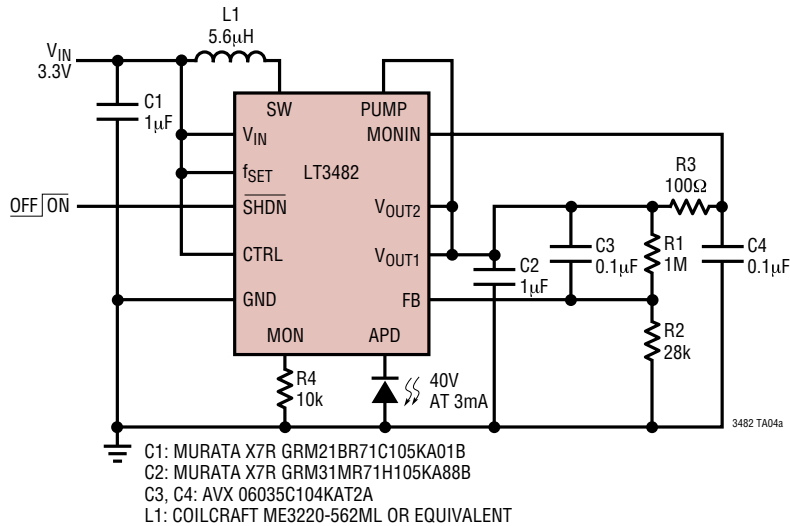

Efficiency

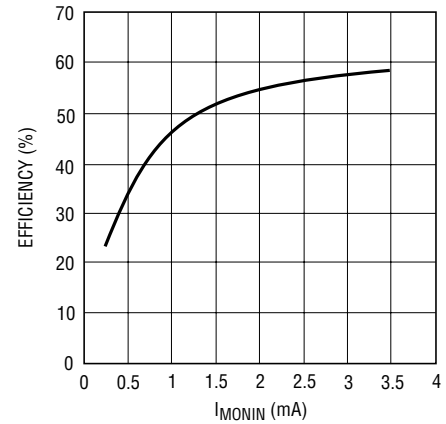

3482 TA04b

RELATED PARTS

PART NUMBER	DESCRIPTION	COMMENTS
LT1930/LT1930A	1A (I_{SW}), 1.2MHz/2.2MHz High Efficiency Step-Up DC/DC Converters	V_{IN} : 2.6V to 16V, $V_{OUT(MAX)}$ = 34V, I_Q = 4.2mA/5.5mA, I_{SD} < 1µA, ThinSOT™ Package
LT3460	0.3A (I_{SW}), 1.3MHz High Efficiency Step-Up DC/DC Converter	V_{IN} : 2.5V to 16V, $V_{OUT(MAX)}$ = 38V, I_Q = 2mA, I_{SD} < 1µA, ThinSOT Package
LT3461/LT3461A	0.3A (I_{SW}), 1.3MHz/3MHz High Efficiency Step-Up DC/DC Converters with Integrated Schottky	V_{IN} : 2.5V to 16V, $V_{OUT(MAX)}$ = 38V, I_Q = 2.8mA, I_{SD} < 1µA, SC70 and ThinSOT Package
LT3465/LT3465A	Constant Current, 1.2MHz/2.7MHz High Efficiency White LED Boost Regulator with Integrated Schottky	V_{IN} : 2.7V to 16V, $V_{OUT(MAX)}$ = 34V, I_Q = 1.9mA, I_{SD} < 1µA, ThinSOT Package

ThinSOT is a trademark on Linear Technology Corporation.

Looking for pricing, stock, or lifecycle information?

Click below to explore more details on WIN SOURCE:

 [View LT3482EUD#PBF on WIN SOURCE](#)

 [Linear Technology](#) Information

Optimize Your Supply Chain with WIN SOURCE Solutions

-  Global Sourcing Solution
-  Obsolete Management
-  Cost Control Management
-  Shortage Management
-  Alternative Solution
-  Excess Inventory Management