



**THE DATASHEET OF  
LT3493EDCB-3#TRMPBF**



# 1.2A, 750kHz Step-Down Switching Regulator in 2mm × 3mm DFN

## FEATURES

- **Wide Input Range: 6.8V to 36V Operating, 40V Maximum**
- **1.2A Output Current**
- **Fixed Frequency Operation: 750kHz**
- Output Adjustable Down to 780mV
- Short-Circuit Robust
- Uses Tiny Capacitors and Inductors
- Soft-Start
- Internally Compensated
- Low Shutdown Current: <2 $\mu$ A
- Low  $V_{CESAT}$  Switch: 330mV at 1A
- Thermally Enhanced, Low Profile 2mm × 3mm DFN-6 Package

## APPLICATIONS

- Automotive Battery Regulation
- Industrial Control Supplies
- Wall Transformer Regulation
- Distributed Supply Regulation
- Battery-Powered Equipment

## DESCRIPTION

The LT<sup>®</sup>3493-3 is a current mode PWM step-down DC/DC converter with an internal 1.75A power switch. The wide operating input range of 6.8V to 36V (40V maximum) makes the LT3493-3 ideal for regulating power from a wide variety of sources, including unregulated wall transformers, 24V industrial supplies and automotive batteries. Its high operating frequency allows the use of tiny, low cost inductors and ceramic capacitors, resulting in low, predictable output ripple.

Cycle-by-cycle current limit provides protection against shorted outputs and soft-start eliminates input current surge during start-up. The low current (<2 $\mu$ A) shutdown mode provides output disconnect, enabling easy power management in battery-powered systems.

LT, LTG and LTM are registered trademarks of Linear Technology Corporation. ThinSOT is a trademark of Linear Technology Corporation. All other trademarks are the property of their respective owners.

## TYPICAL APPLICATION

3.3V Step-Down Converter

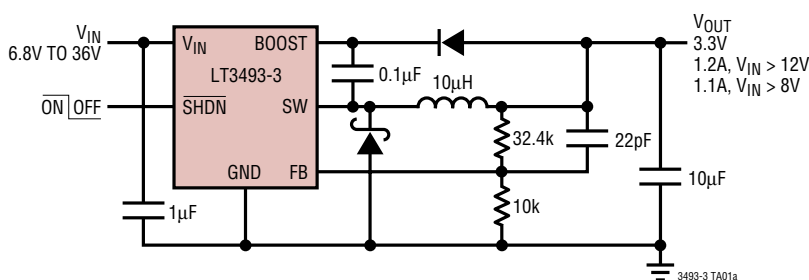

Efficiency

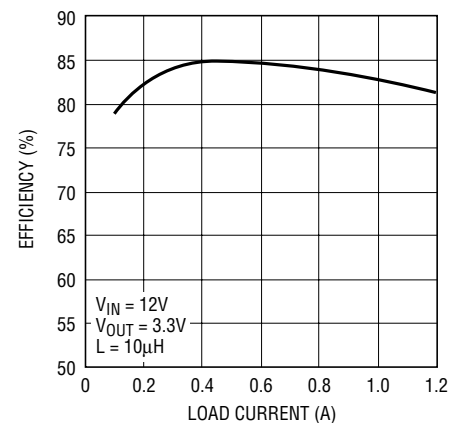

3493-3 TA01b

## ABSOLUTE MAXIMUM RATINGS

(Note 1)

Input Voltage ( $V_{IN}$ ) .....	40V
BOOST Pin Voltage .....	50V
BOOST Pin Above SW Pin .....	25V
SHDN Pin .....	40V
FB Voltage .....	6V
Operating Temperature Range (Note 2)	
LT3493E-3 .....	-40°C to 85°C
Maximum Junction Temperature .....	125°C
Storage Temperature Range .....	-65°C to 150°C

## PACKAGE/ORDER INFORMATION

TOP VIEW

DCB PACKAGE  
6-LEAD (2mm × 3mm) PLASTIC DFN

$T_{JMAX} = 125^{\circ}C$ ,  $\theta_{JA} = 64^{\circ}C/W$   
EXPOSED PAD (PIN 7) IS GND, MUST BE SOLDERED TO PCB

ORDER PART NUMBER	DCB PART MARKING
LT3493EDCB-3	LCGJ

**Order Options** Tape and Reel: Add #TR    Lead Free: Add #PBF  
Lead Free Tape and Reel: Add #TRPBF  
Lead Free Part Marking: <http://www.linear.com/leadfree/>

Consult LTC Marketing for parts specified with wider operating temperature ranges.

## ELECTRICAL CHARACTERISTICS

The ● denotes specifications which apply over the full operating temperature range, otherwise specifications are at  $T_A = 25^{\circ}C$ .  
 $V_{IN} = 12V$ ,  $V_{BOOST} = 17V$ , unless otherwise noted. (Note 2)

PARAMETER	CONDITIONS	MIN	TYP	MAX	UNITS
$V_{IN}$ Operating Range		6.8		36	V
Undervoltage Lockout		6.2	6.5	6.8	V
Feedback Voltage		● 765	780	795	mV
FB Pin Bias Current	$V_{FB} = \text{Measured } V_{REF}$ (Note 4)		● 50	150	nA
Quiescent Current	Not Switching		1.9	2.5	mA
Quiescent Current in Shutdown	$V_{SHDN} = 0V$		0.01	2	$\mu A$
Reference Line Regulation	$V_{IN} = 6.8V$ to 36V		0.007		%/V
Switching Frequency	$V_{FB} = 0.7V$	685	750	815	kHz
	$V_{FB} = 0V$		36		
Maximum Duty Cycle	$T_A = 25^{\circ}C$	● 88	95		%
		91	95		

## ELECTRICAL CHARACTERISTICS

The ● denotes specifications which apply over the full operating temperature range, otherwise specifications are at  $T_A = 25^\circ\text{C}$ .  $V_{IN} = 12\text{V}$ ,  $V_{BOOST} = 17\text{V}$ , unless otherwise noted. (Note 2)

PARAMETER	CONDITIONS	MIN	TYP	MAX	UNITS
Switch Current Limit	(Note 3)	1.4	1.75	2.2	A
Switch $V_{CESAT}$	$I_{SW} = 1\text{A}$		330		mV
Switch Leakage Current				2	$\mu\text{A}$
Minimum Boost Voltage Above Switch	$I_{SW} = 1\text{A}$		1.85	2.2	V
BOOST Pin Current	$I_{SW} = 1\text{A}$		30	50	mA
SHDN Input Voltage High		2.3			V
SHDN Input Voltage Low				0.3	V
SHDN Bias Current	$V_{SHDN} = 2.3\text{V}$ (Note 5) $V_{SHDN} = 0\text{V}$		6 0.01	15 0.1	$\mu\text{A}$ $\mu\text{A}$

**Note 1:** Stresses beyond those listed under Absolute Maximum Ratings may cause permanent damage to the device. Exposure to any Absolute Maximum Rating condition for extended periods may affect device reliability and lifetime.

**Note 2:** The LT3493E-3 is guaranteed to meet performance specifications from  $0^\circ\text{C}$  to  $85^\circ\text{C}$ . Specifications over the  $-40^\circ\text{C}$  to  $85^\circ\text{C}$  operating temperature range are assured by design, characterization and correlation with statistical process controls.

**Note 3:** Current limit guaranteed by design and/or correlation to static test. Slope compensation reduces current limit at higher duty cycle.

**Note 4:** Current flows out of pin.

**Note 5:** Current flows into pin.

## TYPICAL PERFORMANCE CHARACTERISTICS $T_A = 25^\circ\text{C}$ unless otherwise noted.

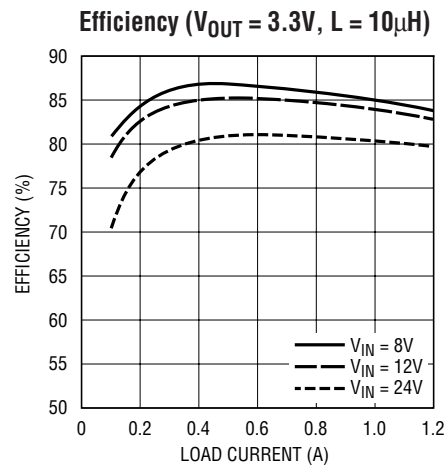
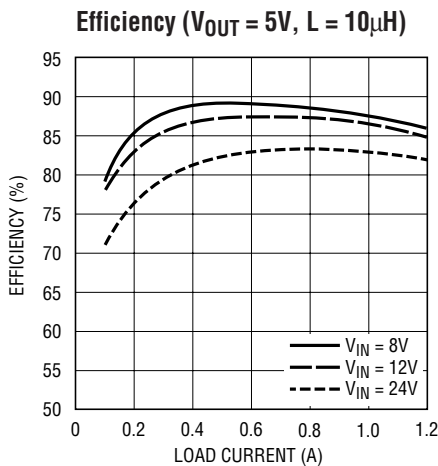

**TYPICAL PERFORMANCE CHARACTERISTICS**  $T_A = 25^\circ\text{C}$  unless otherwise noted.

Maximum Load Current,  
 $V_{OUT} = 5V, L = 8.2\mu\text{H}$

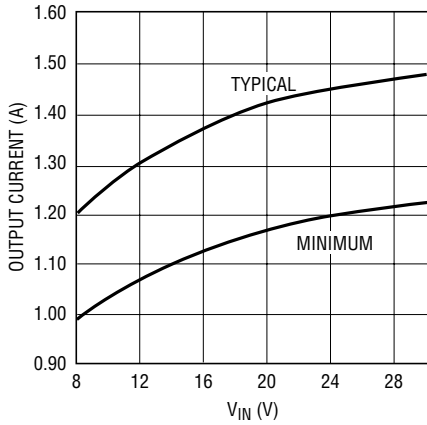

3493-3 G04

Maximum Load Current,  
 $V_{OUT} = 5V, L = 33\mu\text{H}$

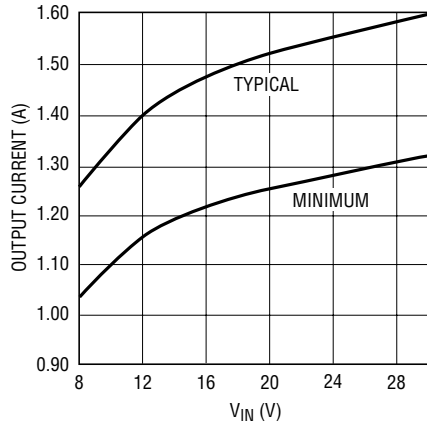

3493-3 G22

Maximum Load Current,  
 $V_{OUT} = 3.3V, L = 4.7\mu\text{H}$

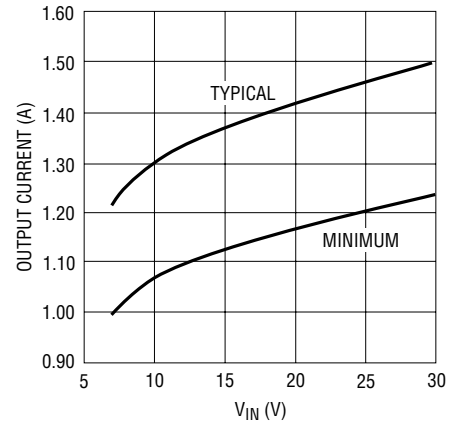

3493-3 G05

Maximum Load Current,  
 $V_{OUT} = 3.3V, L = 10\mu\text{H}$

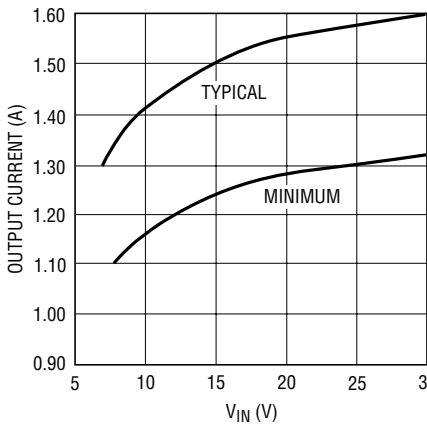

3493-3 G21

Switch Voltage Drop

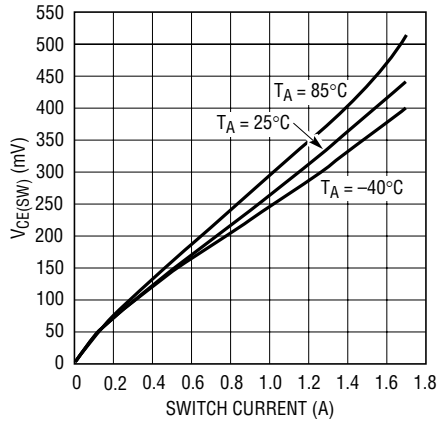

3493-3 G06

Undervoltage Lockout

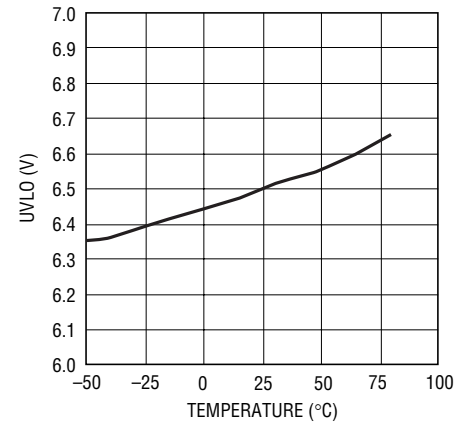

3493-3 G07

Switching Frequency

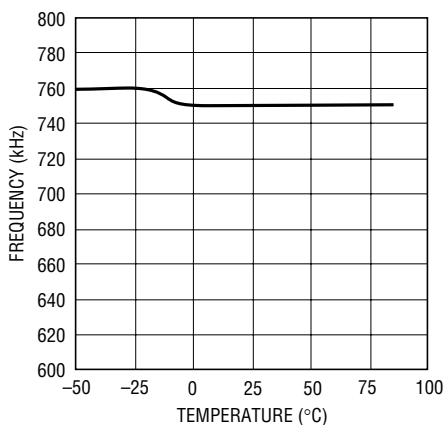

3493-3 G09

Frequency Foldback

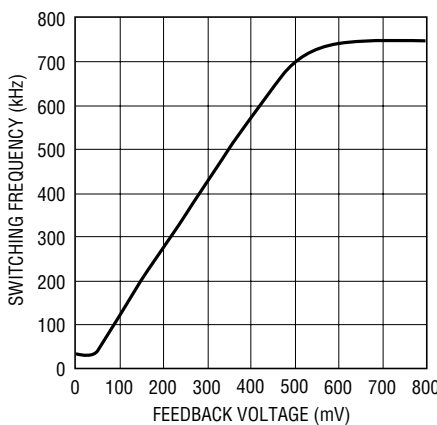

3493-3 G11

Soft-Start

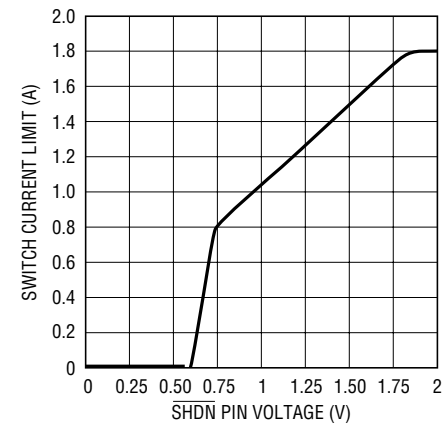

3493-3 G13

**TYPICAL PERFORMANCE CHARACTERISTICS**  $T_A = 25^\circ\text{C}$  unless otherwise noted.

**SHDN Pin Current**

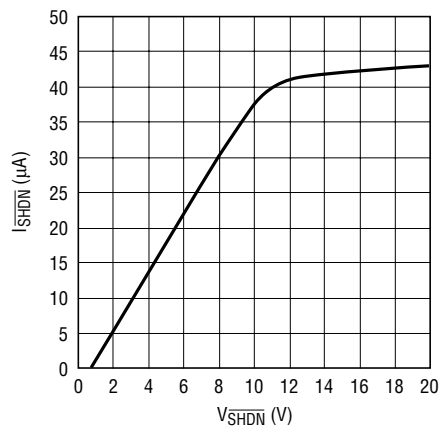

3493-3 G14

**Switch Current Limit**

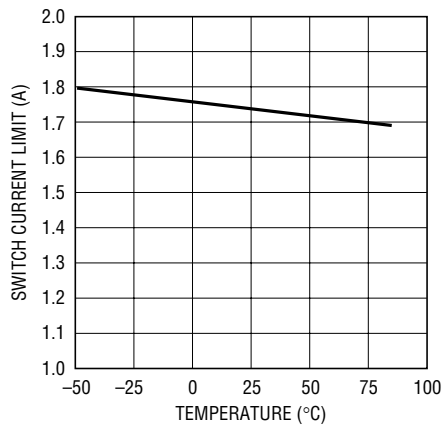

3493-3 G17

**Switch Current Limit**

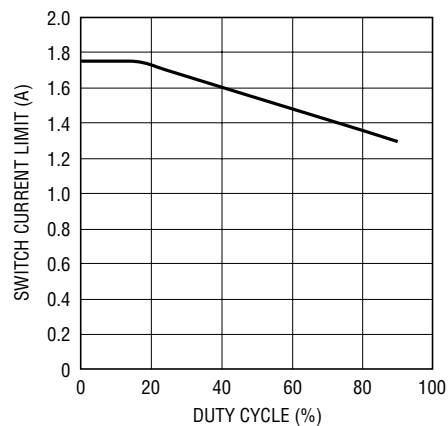

3493-3 G18

**Operating Waveforms**

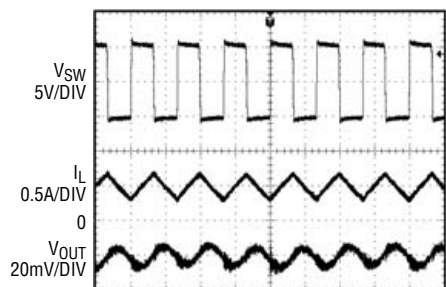

$V_{IN} = 12\text{V}$   
 $V_{OUT} = 3.3\text{V}$   
 $I_{OUT} = 0.5\text{A}$   
 $L = 10\mu\text{H}$   
 $C_{OUT} = 10\mu\text{F}$

3493-3 G19

**Operating Waveforms, Discontinuous Mode**

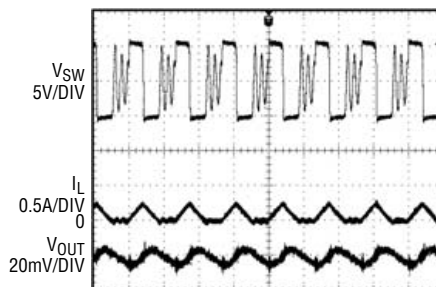

$V_{IN} = 12\text{V}$   
 $V_{OUT} = 3.3\text{V}$   
 $I_{OUT} = 50\text{mA}$   
 $L = 10\mu\text{H}$   
 $C_{OUT} = 10\mu\text{F}$

3493-3 G20

## PIN FUNCTIONS

**FB (Pin 1):** The LT3493-3 regulates its feedback pin to 780mV. Connect the feedback resistor divider tap to this pin. Set the output voltage according to  $V_{OUT} = 0.78V \cdot (1 + R1/R2)$ . A good value for R2 is 10k.

**GND (Pin 2):** Tie the GND pin to a local ground plane below the LT3493-3 and the circuit components. Return the feedback divider to this pin.

**BOOST (Pin 3):** The BOOST pin is used to provide a drive voltage, higher than the input voltage, to the internal bipolar NPN power switch.

**SW (Pin 4):** The SW pin is the output of the internal power switch. Connect this pin to the inductor, catch diode and boost capacitor.

**V<sub>IN</sub> (Pin 5):** The V<sub>IN</sub> pin supplies current to the LT3493-3's internal regulator and to the internal power switch. This pin must be locally bypassed.

**SHDN (Pin 6):** The SHDN pin is used to put the LT3493-3 in shutdown mode. Tie to ground to shut down the LT3493-3. Tie to 2.3V or more for normal operation. If the shutdown feature is not used, tie this pin to the V<sub>IN</sub> pin. SHDN also provides a soft-start function; see the Applications Information section.

**Exposed Pad (Pin 7):** The Exposed Pad must be soldered to the PCB and electrically connected to ground. Use a large ground plane and thermal vias to optimize thermal performance.

## BLOCK DIAGRAM

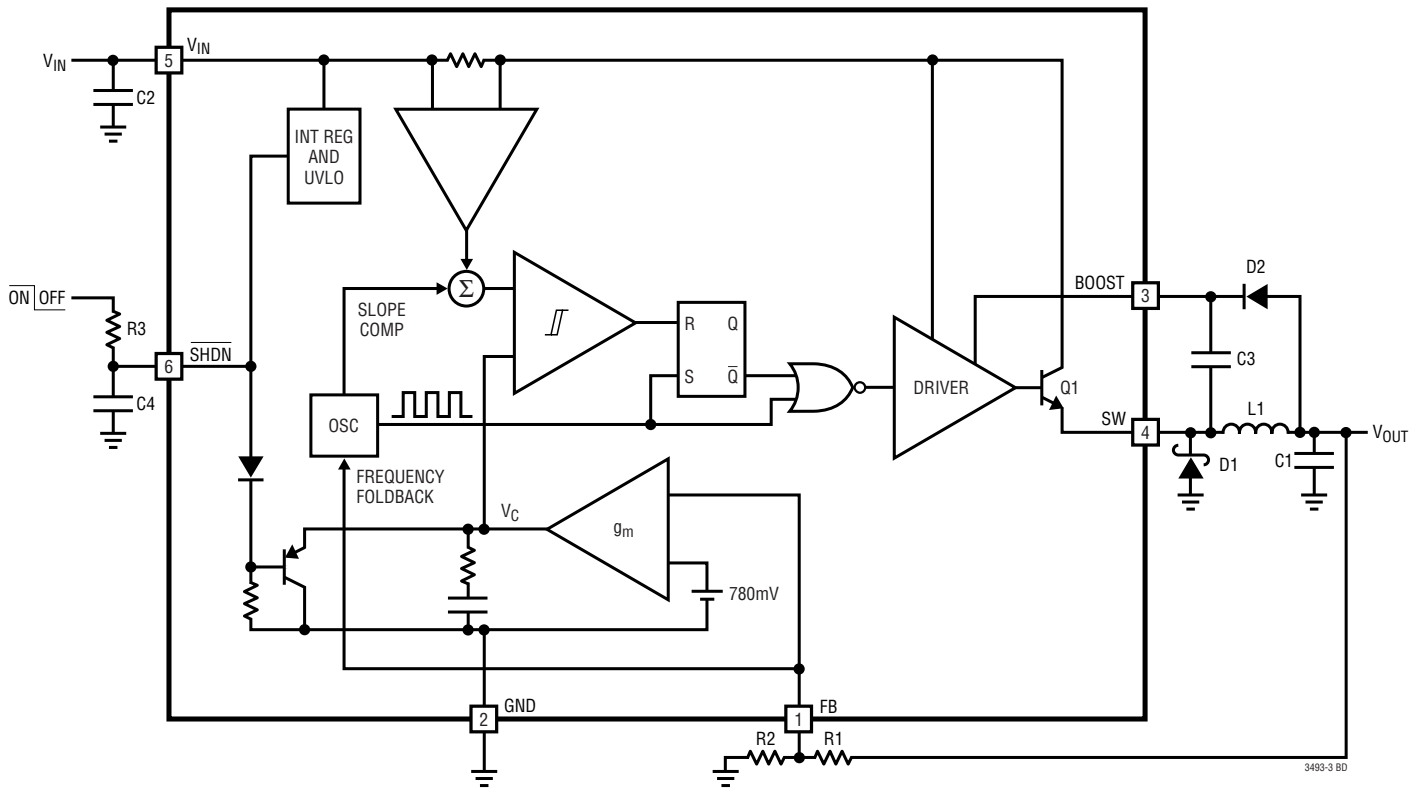

## OPERATION (Refer to Block Diagram)

The LT3493-3 is a constant frequency, current mode step-down regulator. A 750kHz oscillator enables an RS flip-flop, turning on the internal 1.75A power switch Q1. An amplifier and comparator monitor the current flowing between the  $V_{IN}$  and SW pins, turning the switch off when this current reaches a level determined by the voltage at  $V_C$ . An error amplifier measures the output voltage through an external resistor divider tied to the FB pin and servos the  $V_C$  node. If the error amplifier's output increases, more current is delivered to the output; if it decreases, less current is delivered. An active clamp (not shown) on the  $V_C$  node provides current limit. The  $V_C$  node is also clamped to the voltage on the SHDN pin; soft-start is implemented by generating a voltage ramp at the SHDN pin using an external resistor and capacitor.

An internal regulator provides power to the control circuitry. This regulator includes an undervoltage lockout to prevent switching when  $V_{IN}$  is less than 6.8V. The SHDN pin is used to place the LT3493-3 in shutdown, disconnecting the output and reducing the input current to less than 2 $\mu$ A.

The switch driver operates from either the input or from the BOOST pin. An external capacitor and diode are used to generate a voltage at the BOOST pin that is higher than the input supply. This allows the driver to fully saturate the internal bipolar NPN power switch for efficient operation.

The oscillator reduces the LT3493-3's operating frequency when the voltage at the FB pin is low. This frequency foldback helps to control the output current during start-up and overload.

## APPLICATIONS INFORMATION

### FB Resistor Network

The output voltage is programmed with a resistor divider between the output and the FB pin. Choose the 1% resistors according to:

$$R1 = R2 \left( \frac{V_{OUT}}{0.78V} - 1 \right)$$

R2 should be 20k or less to avoid bias current errors. Reference designators refer to the Block Diagram.

An optional phase lead capacitor of 22pF between V<sub>OUT</sub> and FB reduces light-load output ripple.

### Input Voltage Range

The input voltage range for LT3493-3 applications depends on the output voltage and on the absolute maximum ratings of the V<sub>IN</sub> and BOOST pins.

The minimum input voltage is determined by either the LT3493-3's minimum operating voltage of 6.8V, or by its maximum duty cycle. The duty cycle is the fraction of time that the internal switch is on and is determined by the input and output voltages:

$$DC = \frac{V_{OUT} + V_D}{V_{IN} - V_{SW} + V_D}$$

where V<sub>D</sub> is the forward voltage drop of the catch diode (~0.4V) and V<sub>SW</sub> is the voltage drop of the internal switch (~0.4V at maximum load). This leads to a minimum input voltage of:

$$V_{IN(MIN)} = \frac{V_{OUT} + V_D}{DC_{MAX}} - V_D + V_{SW}$$

with DC<sub>MAX</sub> = 0.91 (0.88 over temperature).

The maximum input voltage is determined by the absolute maximum ratings of the V<sub>IN</sub> and BOOST pins. For constant-frequency operation, the maximum input voltage is determined by the minimum duty cycle, DC<sub>MIN</sub> = 0.10. If the duty cycle requirement is less than DC<sub>MIN</sub>, the part will enter pulse-skipping mode. The onset of pulse-skipping occurs at:

$$V_{IN(PS)} = \frac{V_{OUT} + V_D}{DC_{MIN}} - V_D + V_{SW}$$

In pulse-skipping mode, the part skips pulses to control the inductor current and regulate the output voltage, possibly producing a spectrum of frequencies below 750kHz.

Note that this is a restriction on the operating input voltage to remain in constant-frequency operation; the circuit will tolerate transient inputs up to the absolute maximum ratings of the V<sub>IN</sub> and BOOST pins when the output is in regulation. The input voltage should be limited to V<sub>IN(PS)</sub> during overload conditions (short-circuit or start-up).

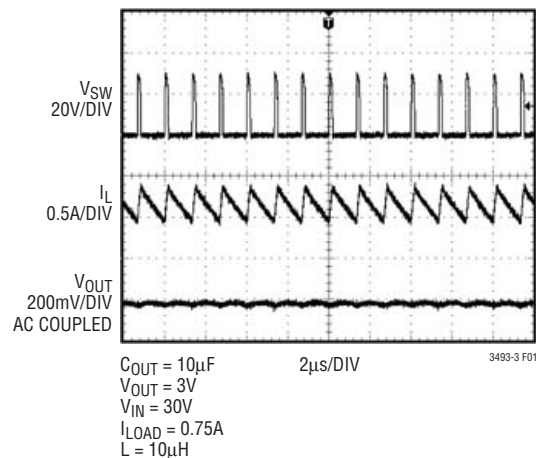

Figure 1

## APPLICATIONS INFORMATION

### Minimum On Time

The part will still regulate the output at input voltages that exceed  $V_{IN(PS)}$  (up to 40V), however, the output voltage ripple increases as the input voltage is increased. Figure 1 illustrates switching waveforms in continuous mode for a 3V output application near  $V_{IN(PS)} = 33V$ .

As the input voltage is increased, the part is required to switch for shorter periods of time. Delays associated with turning off the power switch dictate the minimum on time of the part. The minimum on time for the LT3493-3 is 130ns. Figure 2 illustrates the switching waveforms when the input voltage is increased to  $V_{IN} = 35V$ .

Now the required on time has decreased below the minimum on time of 130ns. Instead of the switch pulse width becoming narrower to accommodate the lower duty cycle requirement, the switch pulse width remains fixed at 130ns. In Figure 2 the inductor current ramps up to a value exceeding the load current and the output ripple increases to ~200mV. The part then remains off until the output voltage dips below 100% of the programmed value before it begins switching again.

Provided that the output remains in regulation and that the inductor does not saturate, operation above  $V_{IN(PS)}$  is safe and will not damage the part. Figure 3 illustrates the switching waveforms when the input voltage is increased to its absolute maximum rating of 40V.

As the input voltage increases, the inductor current ramps up quicker, the number of skipped pulses increases and the output voltage ripple increases. For operation above  $V_{IN(MAX)}$  the only component requirement is that the components be adequately rated for operation at the intended voltage levels.

The part is robust enough to survive prolonged operation under these conditions as long as the peak inductor current does not exceed 2.2A. Inductor current saturation may further limit performance in this operating regime.

### Inductor Selection and Maximum Output Current

A good first choice for the inductor value is:

$$L = 1.6 (V_{OUT} + V_D)$$

where  $V_D$  is the voltage drop of the catch diode (~0.4V) and  $L$  is in  $\mu H$ . With this value there will be no subharmonic oscillation for applications with 50% or greater duty cycle. The inductor's RMS current rating must be greater than your maximum load current and its saturation current should be about 30% higher. For robust operation in fault conditions, the saturation current should be above 2.2A. To keep efficiency high, the series resistance (DCR) should be less than  $0.1\Omega$ . Table 1 lists several vendors and types that are suitable.

Of course, such a simple design guide will not always result in the optimum inductor for your application. A

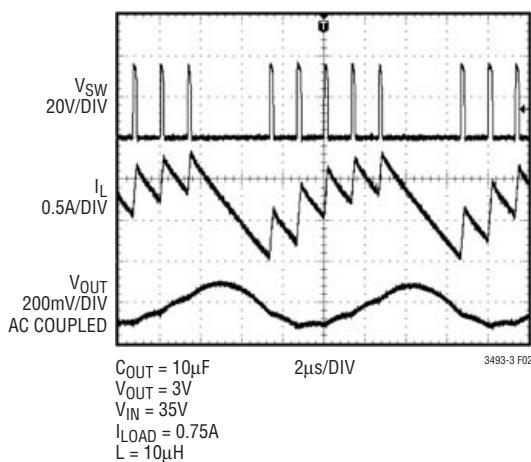

Figure 2

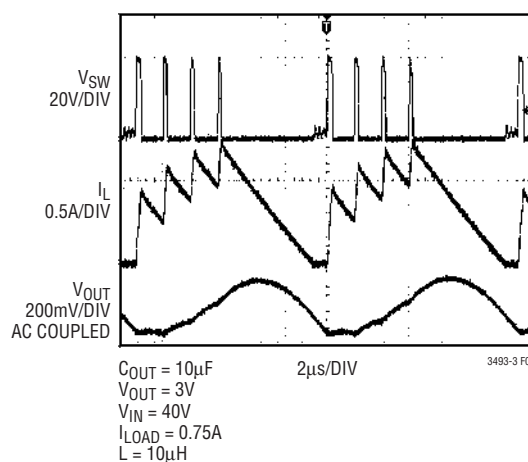

Figure 3

## APPLICATIONS INFORMATION

**Table 1. Inductor Vendors**

Vendor	URL	Part Series	Inductance Range ( $\mu\text{H}$ )	Size (mm)
Sumida	www.sumida.com	CDRH4D28	1.2 to 4.7	4.5 × 4.5
		CDRH5D28	2.5 to 10	5.5 × 5.5
		CDRH8D28	2.5 to 33	8.3 × 8.3
Toko	www.toko.com	A916CY	2 to 12	6.3 × 6.2
		D585LC	1.1 to 39	8.1 × 8.0
Würth Elektronik	www.we-online.com	WE-TPC(M)	1 to 10	4.8 × 4.8
		WE-PD2(M)	2.2 to 22	5.2 × 5.8
		WE-PD(S)	1 to 27	7.3 × 7.3

larger value provides a higher maximum load current and reduces output voltage ripple at the expense of slower transient response. If your load is lower than 1.2A, then you can decrease the value of the inductor and operate with higher ripple current. This allows you to use a physically smaller inductor, or one with a lower DCR resulting in higher efficiency. There are several graphs in the Typical Performance Characteristics section of this data sheet that show the maximum load current as a function of input voltage and inductor value for several popular output voltages. Low inductance may result in discontinuous mode operation, which is okay, but further reduces maximum load current. For details of the maximum output current and discontinuous mode operation, see Linear Technology Application Note 44.

### Catch Diode

Depending on load current, a 1A to 2A Schottky diode is recommended for the catch diode, D1. The diode must have a reverse voltage rating equal to or greater than the maximum input voltage. The ON Semiconductor MBRM140 is a good choice; it is rated for 1A continuous forward current and a maximum reverse voltage of 40V.

### Input Capacitor

Bypass the input of the LT3493-3 circuit with a  $1\mu\text{F}$  or higher value ceramic capacitor of X7R or X5R type. Y5V types have poor performance over temperature and applied voltage and should not be used. A  $1\mu\text{F}$  ceramic is adequate to bypass the LT3493-3 and will easily handle the ripple current. However, if the input power source has high impedance, or there is significant inductance due to long wires or cables, additional bulk capacitance may be

necessary. This can be provided with a low performance electrolytic capacitor.

Step-down regulators draw current from the input supply in pulses with very fast rise and fall times. The input capacitor is required to reduce the resulting voltage ripple at the LT3493-3 and to force this very high frequency switching current into a tight local loop, minimizing EMI. A  $1\mu\text{F}$  capacitor is capable of this task, but only if it is placed close to the LT3493-3 and the catch diode; see the PCB Layout section. A second precaution regarding the ceramic input capacitor concerns the maximum input voltage rating of the LT3493-3. A ceramic input capacitor combined with trace or cable inductance forms a high quality (underdamped) tank circuit. If the LT3493-3 circuit is plugged into a live supply, the input voltage can ring to twice its nominal value, possibly exceeding the LT3493-3's voltage rating. This situation is easily avoided; see the Hot Plugging Safely section.

### Output Capacitor

The output capacitor has two essential functions. Along with the inductor, it filters the square wave generated by the LT3493-3 to produce the DC output. In this role it determines the output ripple so low impedance at the switching frequency is important. The second function is to store energy in order to satisfy transient loads and stabilize the LT3493-3's control loop.

Ceramic capacitors have very low equivalent series resistance (ESR) and provide the best ripple performance. A good value is:

$$C_{\text{OUT}} = 65/V_{\text{OUT}}$$

## APPLICATIONS INFORMATION

**Table 2. Capacitor Vendors**

Vendor	Phone	URL	Part Series	Comments
Panasonic	(714) 373-7366	www.panasonic.com	Ceramic, Polymer, Tantalum	EEF Series
Kemet	(864) 963-6300	www.kemet.com	Ceramic, Tantalum	T494, T495
Sanyo	(408) 749-9714	www.sanyovideo.com	Ceramic, Polymer, Tantalum	POSCAP
Murata	(404) 436-1300	www.murata.com	Ceramic	
AVX		www.avxcorp.com	Ceramic, Tantalum	TPS Series
Taiyo Yuden	(864) 963-6300	www.taiyo-yuden.com	Ceramic	

where  $C_{OUT}$  is in  $\mu\text{F}$ . Use X5R or X7R types and keep in mind that a ceramic capacitor biased with  $V_{OUT}$  will have less than its nominal capacitance. This choice will provide low output ripple and good transient response. Transient performance can be improved with a high value capacitor, but a phase lead capacitor across the feedback resistor R1 may be required to get the full benefit (see the Compensation section).

For small size, the output capacitor can be chosen according to:

$$C_{OUT} = 25/V_{OUT}$$

where  $C_{OUT}$  is in  $\mu\text{F}$ . However, using an output capacitor this small results in an increased loop crossover frequency and increased sensitivity to noise. A 22pF capacitor connected between  $V_{OUT}$  and the FB pin is required to filter noise at the FB pin and ensure stability.

High performance electrolytic capacitors can be used for the output capacitor. Low ESR is important, so choose one that is intended for use in switching regulators. The ESR should be specified by the supplier and should be  $0.1\Omega$  or less. Such a capacitor will be larger than a ceramic capacitor and will have a larger capacitance, because the capacitor must be large to achieve low ESR. Table 2 lists several capacitor vendors.

Figure 4 shows the transient response of the LT3493-3 with several output capacitor choices. The output is 3.3V. The load current is stepped from 250mA to 1A and back to 250mA, and the oscilloscope traces show the output

voltage. The upper photo shows the recommended value. The second photo shows the improved response (less voltage drop) resulting from a larger output capacitor and a phase lead capacitor. The last photo shows the response to a high performance electrolytic capacitor. Transient performance is improved due to the large output capacitance.

### BOOST Pin Considerations

Capacitor C3 and diode D2 are used to generate a boost voltage that is higher than the input voltage. In most cases a  $0.1\mu\text{F}$  capacitor and fast switching diode (such as the 1N4148 or 1N914) will work well. Figure 5 shows two ways to arrange the boost circuit. The BOOST pin must be at least 2.3V above the SW pin for best efficiency. For outputs of 3.3V and above, the standard circuit (Figure 5a) is best. For outputs between 3V and 3.3V, use a  $0.22\mu\text{F}$  capacitor. For outputs between 2.5V and 3V, use a  $0.47\mu\text{F}$  capacitor and a small Schottky diode (such as the BAT-54). For lower output voltages the boost diode can be tied to the input (Figure 5b). The circuit in Figure 5a is more efficient because the BOOST pin current comes from a lower voltage source. You must also be sure that the maximum voltage rating of the BOOST pin is not exceeded.

The minimum operating voltage of an LT3493-3 application is limited by the undervoltage lockout (6.8V) and by the maximum duty cycle as outlined above. For proper start-up, the minimum input voltage is also limited by the boost circuit. If the input voltage is ramped slowly, or the LT3493-3 is turned on with its  $\overline{\text{SHDN}}$  pin when the output

APPLICATIONS INFORMATION

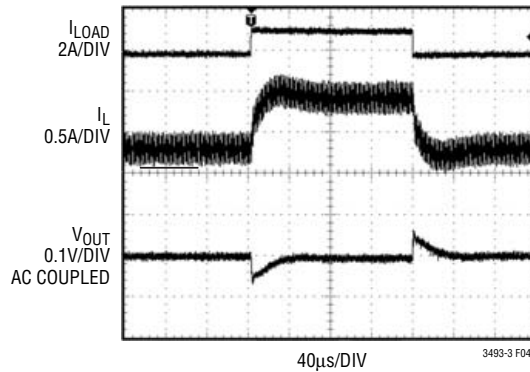
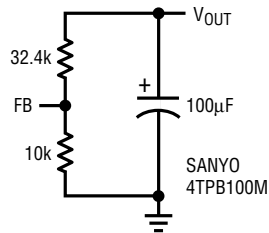
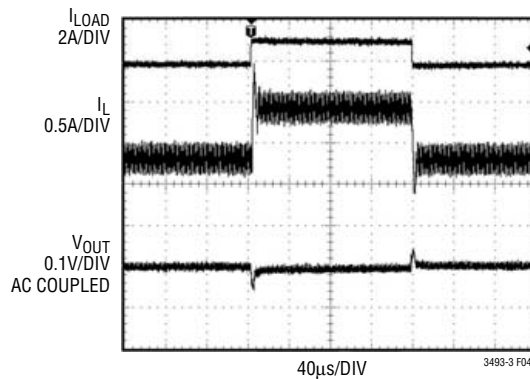
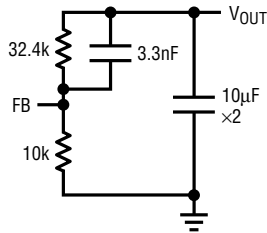
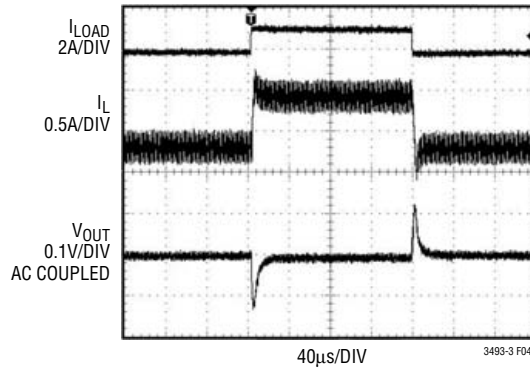
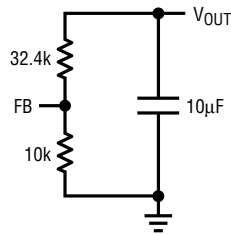

Figure 4. Transient Load Response of the LT3493-3 with Different Output Capacitors as the Load Current is Stepped from 250mA to 1A.  $V_{IN} = 12V$ ,  $V_{OUT} = 3.3V$ ,  $L = 10\mu H$

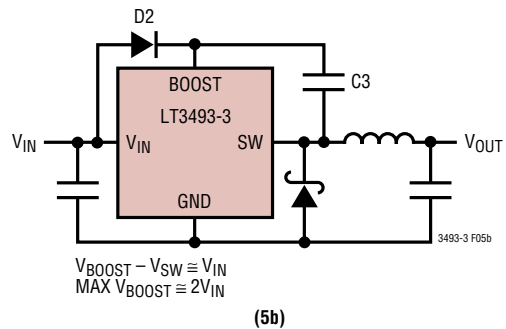
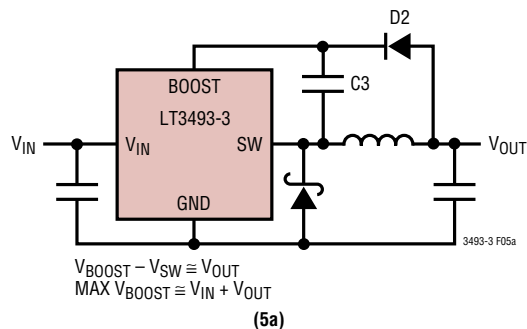

Figure 5. Two Circuits for Generating the Boost Voltage

## APPLICATIONS INFORMATION

is already in regulation, then the boost capacitor may not be fully charged. Because the boost capacitor is charged with the energy stored in the inductor, the circuit will rely on some minimum load current to get the boost circuit running properly. This minimum load will depend on the input and output voltages, and on the arrangement of the boost circuit. The minimum load generally goes to zero once the circuit has started. In many cases the discharged output capacitor will present a load to the switcher which will allow it to start. For 3.3V applications, the undervoltage lockout is high enough (6.8V) that the boost capacitor always gets charged. For 5V applications with output loads less than 20mA, the minimum input voltage required to charge the boost capacitor is 6.8V. Note this higher input voltage requirements is only in worst-case situation where  $V_{IN}$  is being ramped very slowly. For lower start-up voltage, the boost diode can be tied to  $V_{IN}$ ; however this

restricts the input range to one-half of the absolute maximum rating of the BOOST pin.

At light loads, the inductor current becomes discontinuous and the effective duty cycle can be very high. This reduces the minimum input voltage to approximately 400mV above  $V_{OUT}$ . At higher load currents, the inductor current is continuous and the duty cycle is limited by the maximum duty cycle of the LT3493-3, requiring a higher input voltage to maintain regulation.

### Soft-Start

The  $\overline{\text{SHDN}}$  pin can be used to soft-start the LT3493-3, reducing the maximum input current during start-up. The  $\overline{\text{SHDN}}$  pin is driven through an external RC filter to create a voltage ramp at this pin. Figure 6 shows the start-up waveforms with and without the soft-start circuit. By

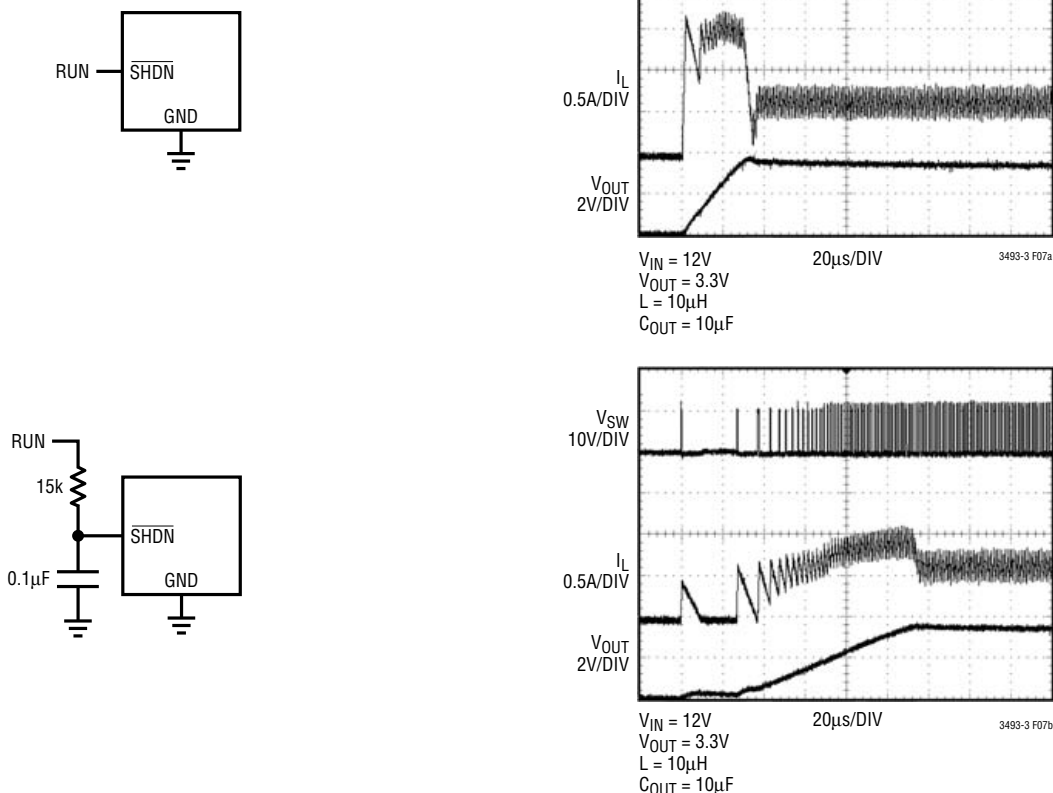

Figure 6. To Soft-Start the LT3493-3, Add a Resistor and Capacitor to the  $\overline{\text{SHDN}}$  pin.  $V_{IN} = 12V$ ,  $V_{OUT} = 3.3V$ ,  $C_{OUT} = 10\mu F$ ,  $R_{LOAD} = 5\Omega$

## APPLICATIONS INFORMATION

choosing a large RC time constant, the peak start up current can be reduced to the current that is required to regulate the output, with no overshoot. Choose the value of the resistor so that it can supply 20 $\mu$ A when the SHDN pin reaches 2.3V.

### Shorted and Reversed Input Protection

If the inductor is chosen so that it won't saturate excessively, an LT3493-3 buck regulator will tolerate a shorted output. There is another situation to consider in systems where the output will be held high when the input to the LT3493-3 is absent. This may occur in battery charging applications or in battery backup systems where a battery or some other supply is diode OR-ed with the LT3493-3's output. If the  $V_{IN}$  pin is allowed to float and the SHDN pin is held high (either by a logic signal or because it is tied to  $V_{IN}$ ), then the LT3493-3's internal circuitry will pull its quiescent current through its SW pin. This is fine if your system can tolerate a few mA in this state. If you ground the SHDN pin, the SW pin current will drop to essentially zero. However, if the  $V_{IN}$  pin is grounded while the output is held high, then parasitic diodes inside the LT3493-3 can pull large currents from the output through the SW pin and the  $V_{IN}$  pin. Figure 7 shows a circuit that will run only when the input voltage is present and that protects against a shorted or reversed input.

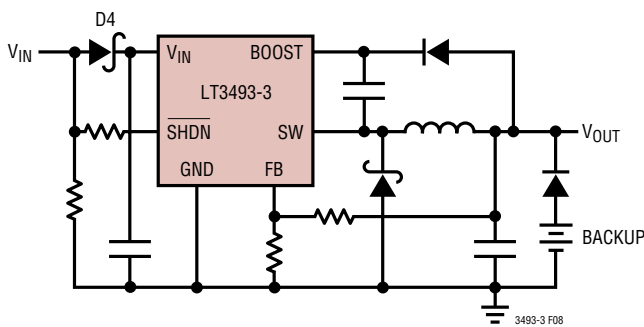

**Figure 7. Diode D4 Prevents a Shorted Input from Discharging a Backup Battery Tied to the Output; It Also Protects the Circuit from a Reversed Input. The LT3493-3 Runs Only When the Input is Present**

### Hot Plugging Safely

The small size, robustness and low impedance of ceramic capacitors make them an attractive option for the input bypass capacitor of LT3493-3 circuits. However, these capacitors can cause problems if the LT3493-3 is plugged into a live supply (see Linear Technology Application Note 88 for a complete discussion). The low loss ceramic capacitor combined with stray inductance in series with the power source forms an underdamped tank circuit, and the voltage at the  $V_{IN}$  pin of the LT3493-3 can ring to twice the nominal input voltage, possibly exceeding the LT3493-3's rating and damaging the part. If the input supply is poorly controlled or the user will be plugging the LT3493-3 into an energized supply, the input network should be designed to prevent this overshoot.

Figure 8 shows the waveforms that result when an LT3493-3 circuit is connected to a 24V supply through six feet of 24-gauge twisted pair. The first plot is the response with a 2.2 $\mu$ F ceramic capacitor at the input. The input voltage rings as high as 35V and the input current peaks at 20A. One method of damping the tank circuit is to add another capacitor with a series resistor to the circuit. In Figure 8b an aluminum electrolytic capacitor has been added. This capacitor's high equivalent series resistance damps the circuit and eliminates the voltage overshoot. The extra capacitor improves low frequency ripple filtering and can slightly improve the efficiency of the circuit, though it is likely to be the largest component in the circuit. An alternative solution is shown in Figure 8c. A 1 $\Omega$  resistor is added in series with the input to eliminate the voltage overshoot (it also reduces the peak input current). A 0.1 $\mu$ F capacitor improves high frequency filtering. This solution is smaller and less expensive than the electrolytic capacitor. For high input voltages its impact on efficiency is minor, reducing efficiency less than one half percent for a 5V output at full load operating from 24V.

## APPLICATIONS INFORMATION

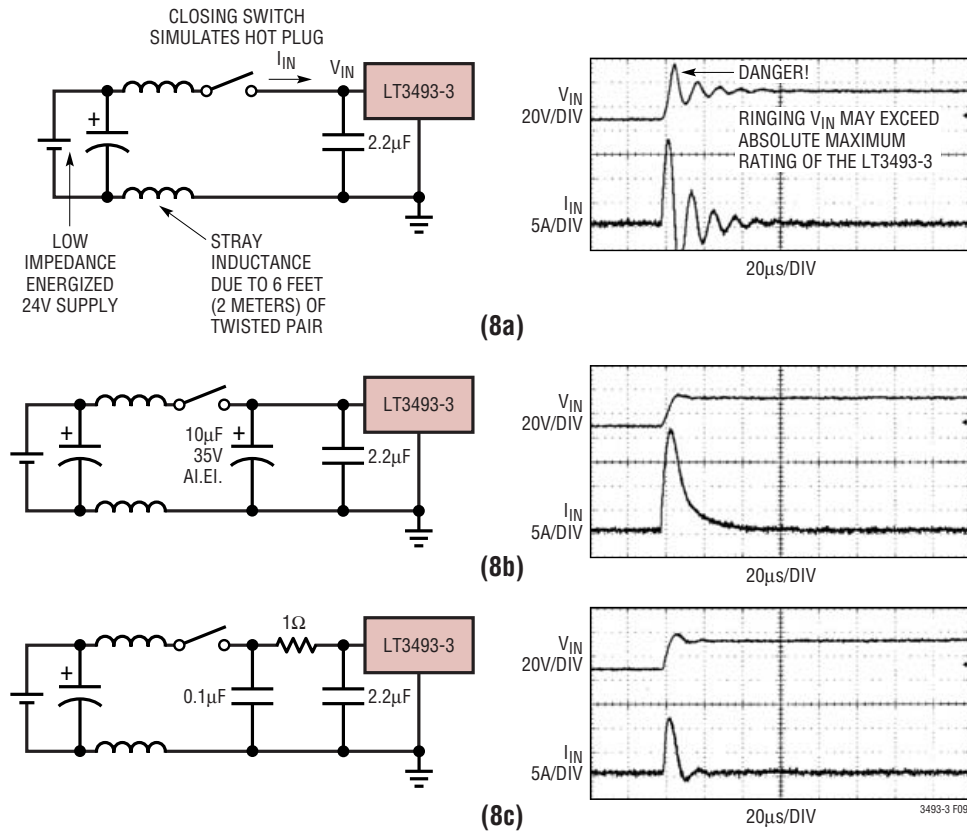

**Figure 8. A Well Chosen Input Network Prevents Input Voltage Overshoot and Ensures Reliable Operation When the LT3493-3 is Connected to a Live Supply**

### Frequency Compensation

The LT3493-3 uses current mode control to regulate the output. This simplifies loop compensation. In particular, the LT3493-3 does not require the ESR of the output capacitor for stability allowing the use of ceramic capacitors to achieve low output ripple and small circuit size.

Figure 9 shows an equivalent circuit for the LT3493-3 control loop. The error amp is a transconductance amplifier with finite output impedance. The power section, consisting of the modulator, power switch and inductor, is modeled as a transconductance amplifier generating an output current proportional to the voltage at the  $V_C$  node. Note that the output capacitor integrates this current, and that the capacitor on the  $V_C$  node ( $C_C$ ) integrates the error amplifier output current, resulting in two poles in the loop.  $R_C$  provides a zero. With the recommended output capacitor, the loop crossover occurs above the  $R_C C_C$  zero. This simple model works well as long as the value of the

inductor is not too high and the loop crossover frequency is much lower than the switching frequency. With a larger ceramic capacitor (very low ESR), crossover may be lower and a phase lead capacitor ( $C_{PL}$ ) across the feedback divider may improve the phase margin and transient

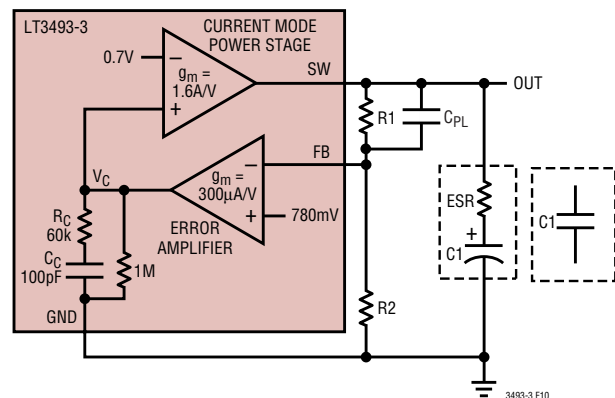

**Figure 9. Model for Loop Response**

## APPLICATIONS INFORMATION

response. Large electrolytic capacitors may have an ESR large enough to create an additional zero, and the phase lead may not be necessary.

If the output capacitor is different than the recommended capacitor, stability should be checked across all operating conditions, including load current, input voltage and temperature. The LT1375 data sheet contains a more thorough discussion of loop compensation and describes how to test the stability using a transient load.

### PCB Layout

For proper operation and minimum EMI, care must be taken during printed circuit board layout. Figure 11 shows the recommended component placement with trace, ground plane and via locations. Note that large, switched currents flow in the LT3493-3's  $V_{IN}$  and SW pins, the catch diode (D1) and the input capacitor (C2). The loop formed by these components should be as small as possible and tied to system ground in only one place. These components, along with the inductor and output capacitor, should be placed on the same side of the circuit board, and their connections should be made on that layer. Place a

local, unbroken ground plane below these components, and tie this ground plane to system ground at one location, ideally at the ground terminal of the output capacitor C1. The SW and BOOST nodes should be as small as possible. Finally, keep the FB node small so that the ground pin and ground traces will shield it from the SW and BOOST nodes. Include vias near the exposed GND pad of the LT3493-3 to help remove heat from the LT3493-3 to the ground plane.

### High Temperature Considerations

The die temperature of the LT3493-3 must be lower than the maximum rating of 125°C. This is generally not a concern unless the ambient temperature is above 85°C. For higher temperatures, care should be taken in the layout of the circuit to ensure good heat sinking of the LT3493-3. The maximum load current should be derated as the ambient temperature approaches 125°C. The die temperature is calculated by multiplying the LT3493-3 power dissipation by the thermal resistance from junction to ambient. Power dissipation within the LT3493-3 can be estimated by calculating the total power loss from an efficiency measurement and subtracting the catch diode

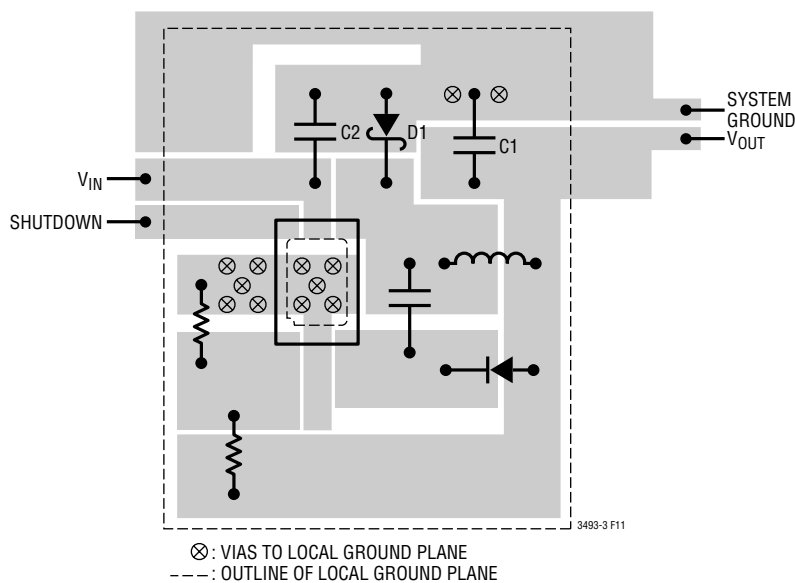

Figure 10. A Good PCB Layout Ensures Proper, Low EMI Operation

## APPLICATIONS INFORMATION

loss. The resulting temperature rise at full load is nearly independent of input voltage. Thermal resistance depends on the layout of the circuit board, but 64°C/W is typical for the (2mm × 3mm) DFN (DCB) package.

### Outputs Greater Than 6V

For outputs greater than 6V, add a resistor of 1k to 2.5k across the inductor to damp the discontinuous ringing of the SW node, preventing unintended SW current. The 12V Step-Down Converter circuit in the Typical Applications section shows the location of this resistor. Also note that for outputs above 6V, the input voltage range will be

limited by the maximum rating of the BOOST pin. The 12V circuit shows how to overcome this limitation using an additional zener diode.

### Other Linear Technology Publications

Application notes AN19, AN35 and AN44 contain more detailed descriptions and design information for Buck regulators and other switching regulators. The LT1376 data sheet has a more extensive discussion of output ripple, loop compensation and stability testing. Design Note DN100 shows how to generate a bipolar output supply using a Buck regulator.

## TYPICAL APPLICATIONS

0.78V Step-Down Converter

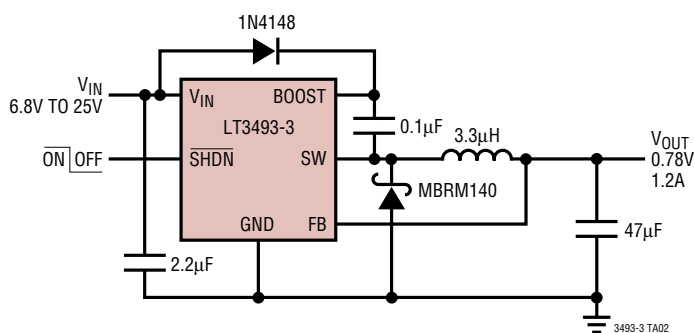

1.8V Step-Down Converter

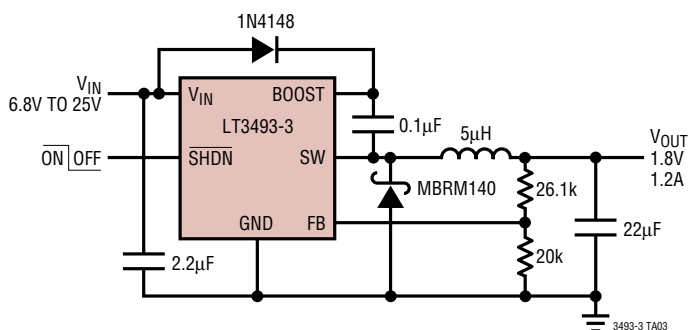

**TYPICAL APPLICATIONS**

**2.5V Step-Down Converter**

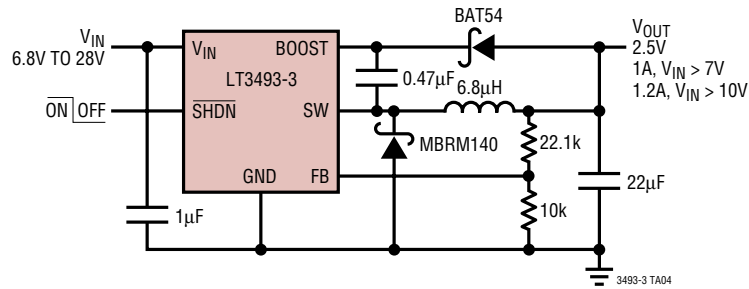

**3.3V Step-Down Converter**

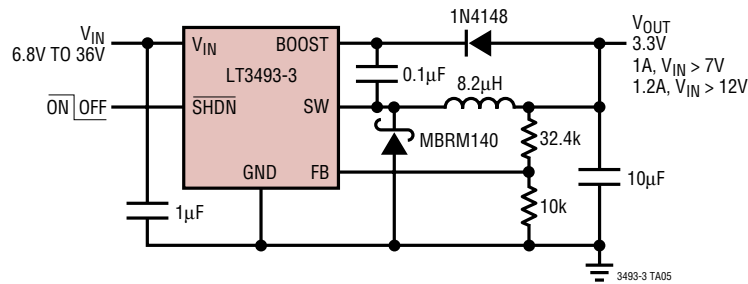

**5V Step-Down Converter**

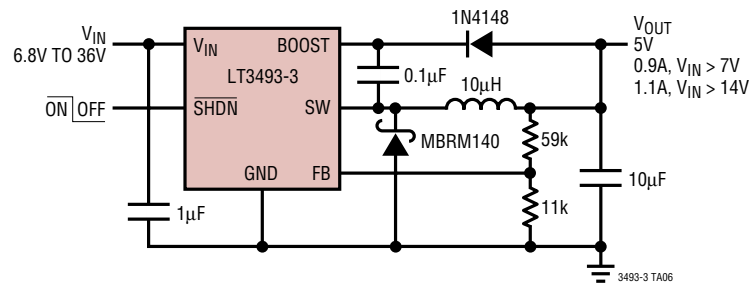

# PACKAGE DESCRIPTION

## DCB Package 6-Lead Plastic DFN (2mm × 3mm) (Reference LTC DWG # 05-08-1715)

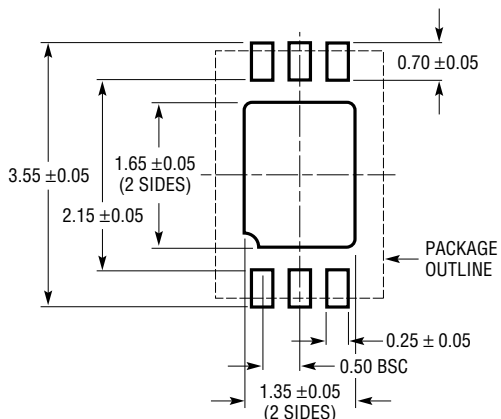

RECOMMENDED SOLDER PAD PITCH AND DIMENSIONS

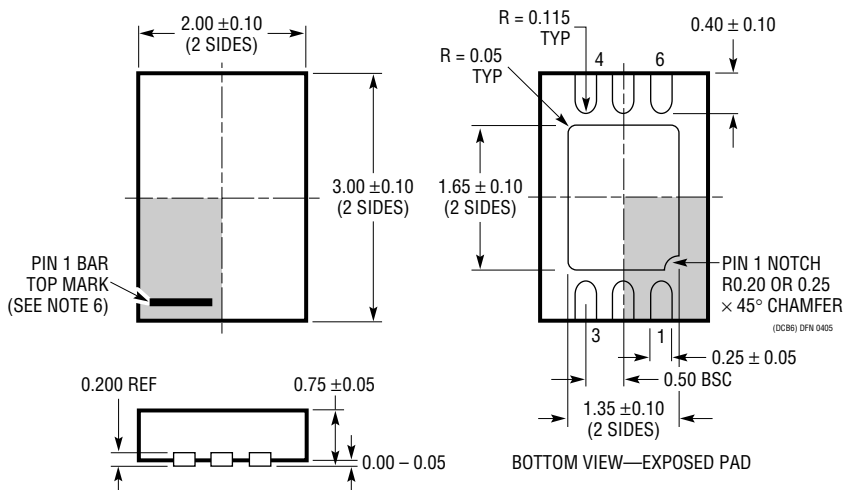

NOTE:

1. DRAWING TO BE MADE A JEDEC PACKAGE OUTLINE M0-229 VARIATION OF (TBD)
2. DRAWING NOT TO SCALE
3. ALL DIMENSIONS ARE IN MILLIMETERS
4. DIMENSIONS OF EXPOSED PAD ON BOTTOM OF PACKAGE DO NOT INCLUDE MOLD FLASH. MOLD FLASH, IF PRESENT, SHALL NOT EXCEED 0.15mm ON ANY SIDE
5. EXPOSED PAD SHALL BE SOLDER PLATED
6. SHADED AREA IS ONLY A REFERENCE FOR PIN 1 LOCATION ON THE TOP AND BOTTOM OF PACKAGE

Information furnished by Linear Technology Corporation is believed to be accurate and reliable. However, no responsibility is assumed for its use. Linear Technology Corporation makes no representation that the interconnection of its circuits as described herein will not infringe on existing patent rights.

## TYPICAL APPLICATION

### 12V Step-Down Converter

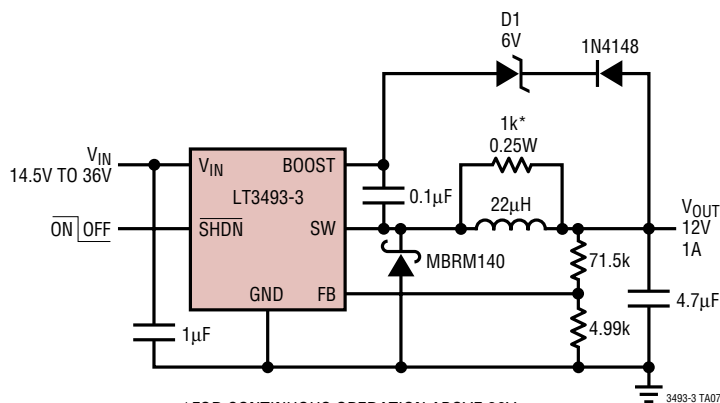

\* FOR CONTINUOUS OPERATION ABOVE 30V  
USE TWO 2k, 0.25W RESISTORS IN PARALLEL.  
D1: CMDZ5235B

## RELATED PARTS

PART NUMBER	DESCRIPTION	COMMENTS
LT1766	60V, 1.2A I <sub>OUT</sub> , 200kHz, High Efficiency Step-Down DC/DC Converter	V <sub>IN</sub> : 5.5V to 60V, V <sub>OUT(MIN)</sub> = 1.2V, I <sub>Q</sub> = 2.5mA, I <sub>SD</sub> = 25µA, TSSOP16 and TSSOP16E Packages
LT1767	25V, 1.2A I <sub>OUT</sub> , 1.2MHz, High Efficiency Step-Down DC/DC Converter	V <sub>IN</sub> : 3V to 25V, V <sub>OUT(MIN)</sub> = 1.2V, I <sub>Q</sub> = 1mA, I <sub>SD</sub> = 6µA, MS8E Package
LT1933	500mA I <sub>OUT</sub> , 500kHz Step-Down Switching Regulator in SOT-23	V <sub>IN</sub> : 3.6V to 36V, V <sub>OUT(MIN)</sub> = 1.2V, I <sub>Q</sub> = 1.6mA, I <sub>SD</sub> = 1µA, ThinSOT Package
LT1936	36V, 1.4A I <sub>OUT</sub> , 500kHz, High Efficiency Step-Down DC/DC Converter	V <sub>IN</sub> : 3.6V to 36V, V <sub>OUT(MIN)</sub> = 1.2V, I <sub>Q</sub> = 1.9mA, I <sub>SD</sub> = 1µA, MS8E Package
LT1940	Dual 25V, 1.4A I <sub>OUT</sub> , 1.1MHz, High Efficiency Step-Down DC/DC Converter	V <sub>IN</sub> : 3.6V to 25V, V <sub>OUT(MIN)</sub> = 1.2V, I <sub>Q</sub> = 3.5mA, I <sub>SD</sub> = <30µA, TSSOP16E Package
LT1976/LT1977	60V, 1.2A I <sub>OUT</sub> , 200kHz to 500kHz, High Efficiency Step-Down DC/DC Converter with Burst Mode® Operation	V <sub>IN</sub> : 3.3V to 60V, V <sub>OUT(MIN)</sub> = 1.2V, I <sub>Q</sub> = 100µA, I <sub>SD</sub> = <1µA, TSSOP16E Package
LT3434/LT3435	60V, 2.4A I <sub>OUT</sub> , 200kHz to 500kHz, High Efficiency Step-Down DC/DC Converter with Burst Mode Operation	V <sub>IN</sub> : 3.3V to 60V, V <sub>OUT(MIN)</sub> = 1.2V, I <sub>Q</sub> = 100µA, I <sub>SD</sub> = <1µA, TSSOP16E Package
LT3437	60V, 400mA I <sub>OUT</sub> , MicroPower Step-Down DC/DC Converter with Burst Mode Operation	V <sub>IN</sub> : 3.3V to 60V, V <sub>OUT(MIN)</sub> = 1.25V, I <sub>Q</sub> = 100µA, I <sub>SD</sub> = <1µA, 3mm × 3mm DFN-10 and TSSOP16E Packages
LT3481	34V, 2A I <sub>OUT</sub> , 3MHz, MicroPower Step-Down DC/DC Converter with I <sub>Q</sub> = 50µA	V <sub>IN</sub> : 3.3V to 34V, V <sub>OUT(MIN)</sub> = 1.265V, I <sub>Q</sub> = 50µA, I <sub>SD</sub> = 1µA, 3mm × 3mm DFN-10 and MS10E Packages
LT3493	36V, 1.4A I <sub>OUT</sub> , 750MHz, High Efficiency Step-Down DC/DC Converter	V <sub>IN</sub> : 3.6V to 36V, V <sub>OUT(MIN)</sub> = 0.8V, I <sub>Q</sub> = 1.9mA, I <sub>SD</sub> = 1µA, 2mm × 3mm DFN Package
LT3505	36V, 1.2A I <sub>OUT</sub> , 750kHz, High Efficiency Step-Down DC/DC Converter	V <sub>IN</sub> : 3.6V to 36V, V <sub>OUT(MIN)</sub> = 0.8V, I <sub>Q</sub> = 1.9mA, I <sub>SD</sub> = 1µA, 3mm × 3mm DFN-8 and MS8E Packages
LT3506/LT3506A	Dual 25V, 1.6A I <sub>OUT</sub> , 575kHz to 1.1MHz, High Efficiency Step-Down DC/DC Converter	V <sub>IN</sub> : 3.6V to 25V, V <sub>OUT(MIN)</sub> = 0.8V, I <sub>Q</sub> = 3.8mA, I <sub>SD</sub> = <30µA, 4mm × 5mm DFN-16 Package

Burst Mode is a registered trademark of Linear Technology Corporation.

## Looking for pricing, stock, or lifecycle information?

Click below to explore more details on WIN SOURCE:

 [View LT3493EDCB-3#TRMPBF on WIN SOURCE](#)

 [Linear Technology](#) Information

## Optimize Your Supply Chain with WIN SOURCE Solutions

-  Global Sourcing Solution
-  Obsolete Management
-  Cost Control Management
-  Shortage Management
-  Alternative Solution
-  Excess Inventory Management