



**THE DATASHEET OF
LT3502IMS#PBF**



1.1MHz/2.2MHz, 500mA Step-Down Regulators in 2mm × 2mm DFN and MS10

FEATURES

- 3V to 40V Input Voltage Range
- 500mA Output Current
- Switching Frequency: 2.2MHz (LT3502A), 1.1MHz (LT3502)
- 800mV Feedback Voltage
- Short-Circuit Robust
- Soft-Start
- Low Shutdown Current: <math><2\mu\text{A}</math>
- Internally Compensated
- Internal Boost Diode
- Thermally Enhanced 2mm × 2mm 8-Lead DFN and 10-Lead MS10 Package

APPLICATIONS

- Automotive Systems
- Battery-Powered Equipment
- Wall Transformer Regulation
- Distributed Supply Regulation

DESCRIPTION

The LT[®]3502/LT3502A are current mode PWM step-down DC/DC converters with an internal 500mA power switch, in tiny 8-lead 2mm × 2mm DFN and 10-lead MS10 packages. The wide input voltage range of 3V to 40V makes the LT3502/LT3502A suitable for regulating power from a wide variety of sources, including 24V industrial supplies and automotive batteries. Its high operating frequency allows the use of tiny, low cost inductors and capacitors, resulting in a very small solution. Constant frequency above the AM band avoids interfering with radio reception, making the LT3502A particularly suitable for automotive applications.

Cycle-by-cycle current limit and frequency foldback provide protection against shorted outputs. Soft-start and frequency foldback eliminates input current surge during start-up. DA current sense provides further protection in fault conditions. An internal boost diode reduces component count.

LT, LT, LTC, LTM, Linear Technology and the Linear logo are registered trademarks of Linear Technology Corporation. All other trademarks are the property of their respective owners.

TYPICAL APPLICATION

3.3V Step-Down Converter

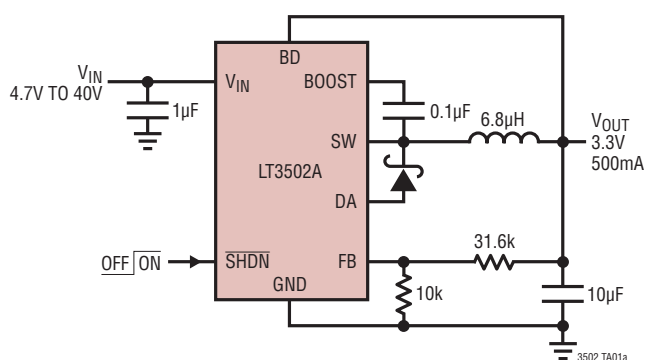

LT3502A 12VIN Efficiency

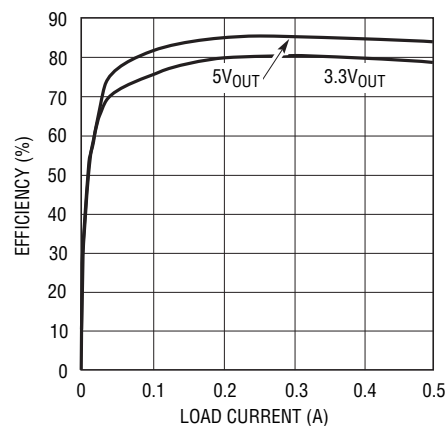

LT3502/LT3502A

ABSOLUTE MAXIMUM RATINGS (Note 1)

Input Voltage (V_{IN}).....	40V	BD Voltage	7V
BOOST Voltage	50V	Operating Junction Temperature Range (Note 2)	
BOOST Pin Above SW Pin.....	7V	LT3502AE, LT3502E	-40°C to 125°C
FB Voltage.....	6V	LT3502AI, LT3502I	-40°C to 125°C
SHDN Voltage	40V	Storage Temperature Range	-65°C to 150°C

PIN CONFIGURATION

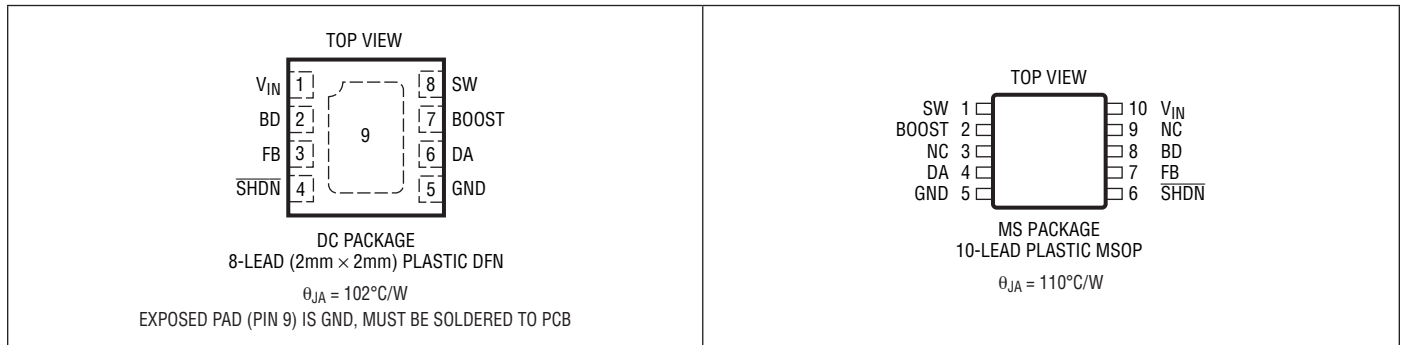

ORDER INFORMATION

LEAD FREE FINISH	TAPE AND REEL	PART MARKING*	PACKAGE DESCRIPTION	TEMPERATURE RANGE
LT3502EDC#PBF	LT3502EDC#TRPBF	LCLV	8-Lead 2mm × 2mm Plastic DFN	-40°C to 125°C
LT3502IDC#PBF	LT3502IDC#TRPBF	LCLV	8-Lead 2mm × 2mm Plastic DFN	-40°C to 125°C
LT3502AEDC#PBF	LT3502AEDC#TRPBF	LCLT	8-Lead 2mm × 2mm Plastic DFN	-40°C to 125°C
LT3502AIDC#PBF	LT3502AIDC#TRPBF	LCLT	8-Lead 2mm × 2mm Plastic DFN	-40°C to 125°C
LT3502EMS#PBF	LT3502EMS#TRPBF	LTDTR	10-Lead Plastic MSOP	-40°C to 125°C
LT3502IMS#PBF	LT3502IMS#TRPBF	LTDTR	10-Lead Plastic MSOP	-40°C to 125°C
LT3502AEMS#PBF	LT3502AEMS#TRPBF	LTDTS	10-Lead Plastic MSOP	-40°C to 125°C
LT3502AIMS#PBF	LT3502AIMS#TRPBF	LTDTS	10-Lead Plastic MSOP	-40°C to 125°C

Consult LTC Marketing for parts specified with wider operating temperature ranges. *The temperature grade is identified by a label on the shipping container. Consult LTC Marketing for information on non-standard lead based finish parts.

For more information on lead free part marking, go to: <http://www.linear.com/leadfree/>

For more information on tape and reel specifications, go to: <http://www.linear.com/tapeandreeel/>

ELECTRICAL CHARACTERISTICS

The ● denotes the specifications which apply over the full operating temperature range, otherwise specifications are at $T_A = 25^\circ\text{C}$. $V_{IN} = 10\text{V}$, $V_{SHDN} = 5\text{V}$, $V_{BOOST} = 15\text{V}$.

PARAMETER	CONDITIONS	MIN	TYP	MAX	UNITS	
Undervoltage Lockout		2.6	2.8	3	V	
Quiescent Current at Shutdown	$V_{SHDN} = 0\text{V}$		0.5	2	μA	
Quiescent Current	Not Switching		1.5	2	mA	
Feedback Voltage	2mm × 2mm DFN	● 0.785	0.8	0.813	V	
	2mm × 2mm DFN	● 0.79	0.8	0.81	V	
	MS10	● 0.780	0.8	0.816	V	
	MS10	● 0.786	0.8	0.813	V	
Reference Voltage Line Regulation			0.005		%/V	
FB Pin Bias Current	(Note 5)	●	15	50	nA	
Switching Frequency	$I_{DA} < 500\text{mA}$ (LT3502A)	●	1.9	2.25	2.7	MHz
	$I_{DA} < 500\text{mA}$ (LT3502A)	●	1.8	2.25	2.8	MHz
	$I_{DA} < 500\text{mA}$ (LT3502)	●	0.9	1.1	1.3	MHz
	$I_{DA} < 500\text{mA}$ (LT3502)	●	0.8	1.1	1.4	MHz
Maximum Duty Cycle	100mA Load (LT3502A)		70	80	%	
	100mA Load (LT3502)		80	90	%	
Switch V_{CESAT}	$I_{SW} = 500\text{mA}$		450		mV	
Switch Current Limit	(Note 3)	0.75	0.9	1.1	A	
Switch Active Current	SW = 10V (Note 4)		95	130	μA	
	SW = 0V (Note 5)		8	30	μA	
BOOST Pin Current	$I_{SW} = 500\text{mA}$		10	13	mA	
Minimum BOOST Voltage Above Switch	$I_{SW} = 500\text{mA}$		1.9	2.2	V	
BOOST Schottky Forward Drop	$I_{OUT} = 100\text{mA}$		0.8	1	V	
DA Pin Current to Stop OSC		500	650		mA	
SHDN Bias Current	$V_{SHDN} = 5\text{V}$		55	80	μA	
	$V_{SHDN} = 0\text{V}$			1	μA	
SHDN Input Voltage High		2			V	
SHDN Input Voltage Low				0.3	V	

Note 1: Stresses beyond those listed under Absolute Maximum Ratings may cause permanent damage to the device. Exposure to any Absolute Maximum Rating condition for extended periods may affect device reliability and lifetime.

Note 2: The LT3502EDC and LT3502AEDC are guaranteed to meet performance specifications from 0°C to 125°C junction temperature range. Specifications over the -40°C to 125°C operating junction temperature range are assured by design, characterization and correlation

with statistical process controls. The LT3502IDC and LT3502AIDC are guaranteed over the -40°C to 125°C operating junction temperature range.

Note 3: Current limit guaranteed by design and/or correlation to static test. Slope compensation reduces current limit at higher duty cycle.

Note 4: Current flows into pin.

Note 5: Current flows out of pin.

TYPICAL PERFORMANCE CHARACTERISTICS ($T_A = 25^\circ\text{C}$ unless otherwise noted)

LT3502A 3.3V_{OUT} Efficiency

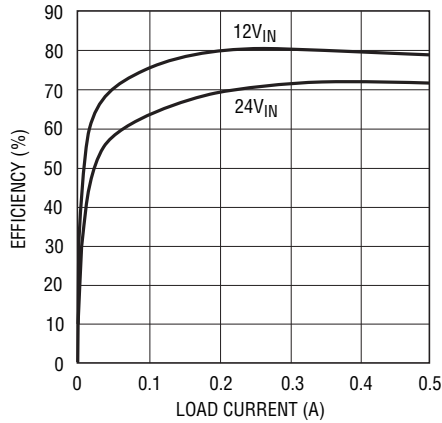

LT3502A 5V_{OUT} Efficiency

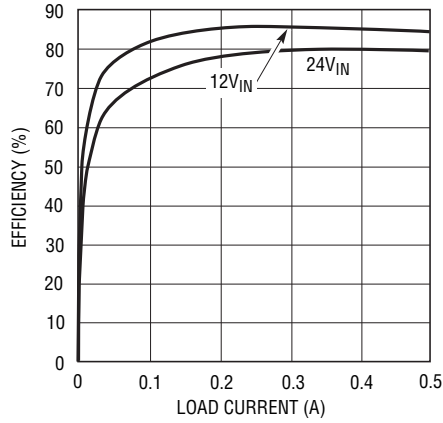

LT3502 3.3V_{OUT} Efficiency

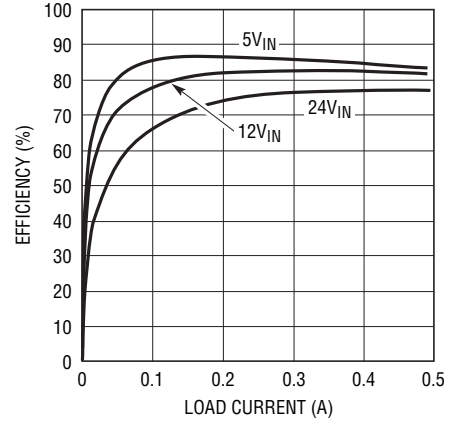

LT3502 5V_{OUT} Efficiency

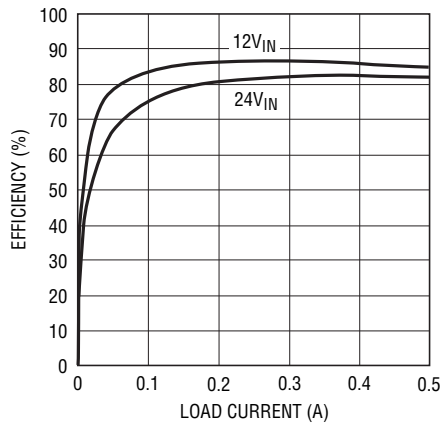

**LT3502A Maximum Load Current
V_{OUT} = 3.3V, L = 6.8μH**

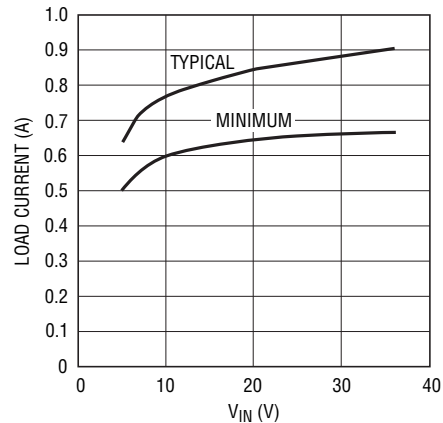

**LT3502A Maximum Load Current
V_{OUT} = 5V, L = 10μH**

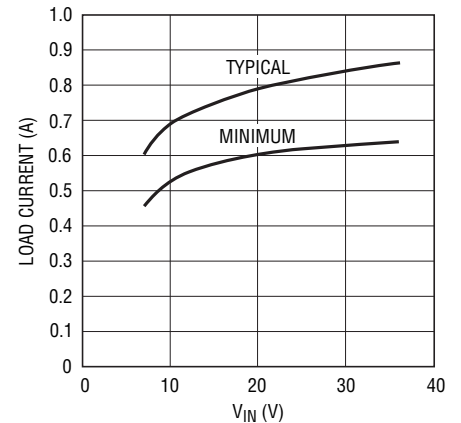

**LT3502 Maximum Load Current
V_{OUT} = 3.3V, L = 15μH**

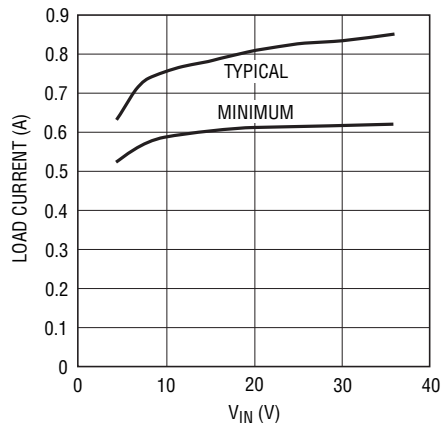

**LT3502 Maximum Load Current
V_{OUT} = 5V, L = 22μH**

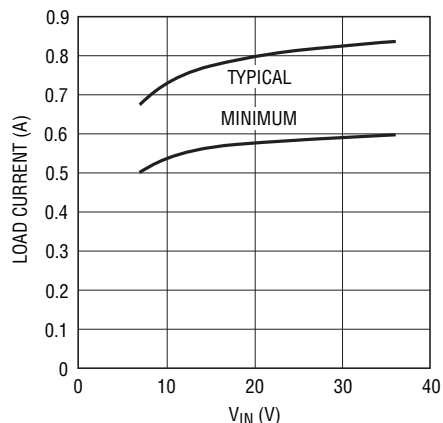

Switch Voltage Drop

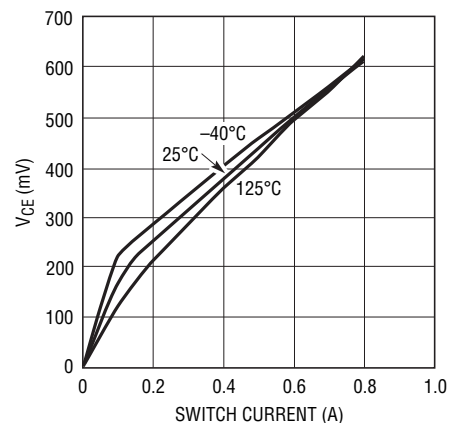

TYPICAL PERFORMANCE CHARACTERISTICS ($T_A = 25^\circ\text{C}$ unless otherwise noted)

UVLO

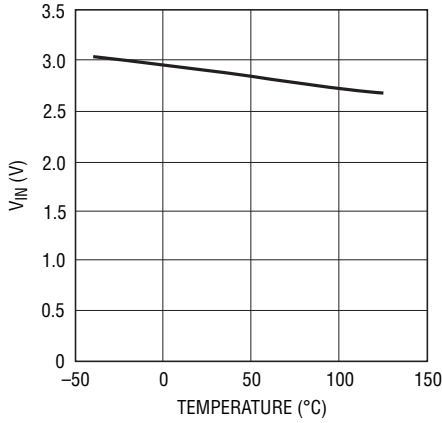

3502 G10

Switching Frequency

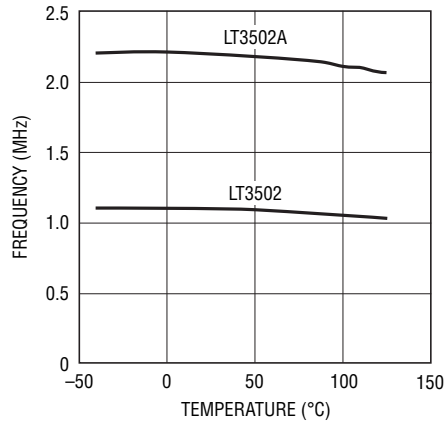

3502 G11

Soft-Start ($\overline{\text{SHDN}}$)

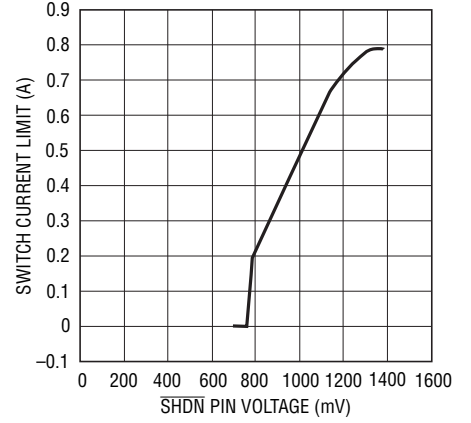

3502 G12

$\overline{\text{SHDN}}$ Pin Current

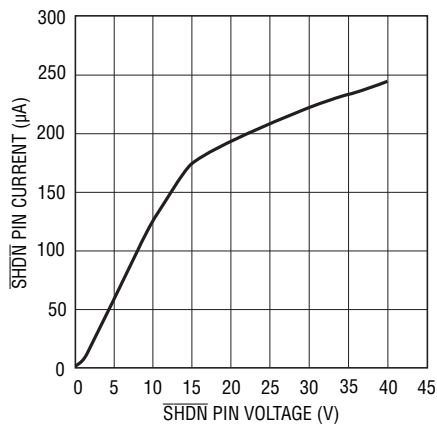

3502 G13

Switch Current Limit

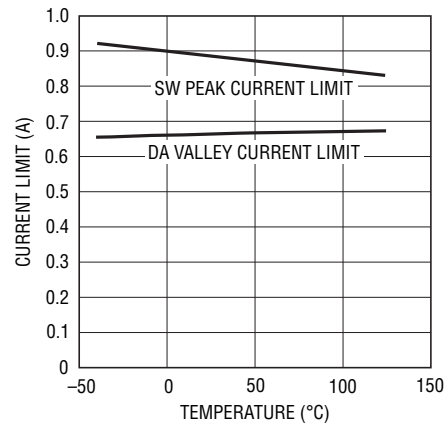

3502 G14

Switch Current Limit

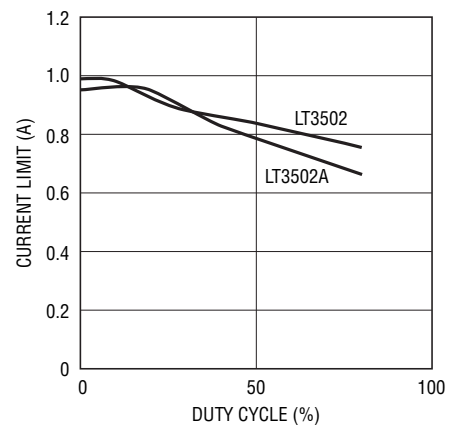

3502 G15

LT3502A Maximum V_{IN} for Full Frequency ($V_{OUT} = 3.3\text{V}$)

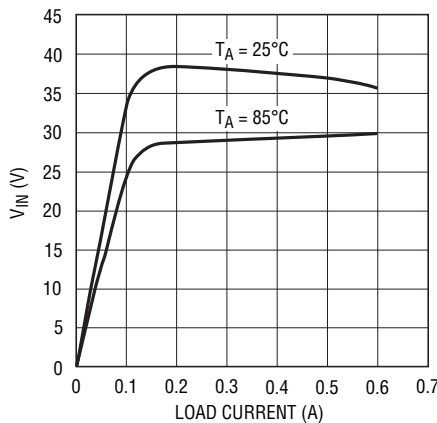

3502 G16

LT3502A Maximum V_{IN} for Full Frequency ($V_{OUT} = 5\text{V}$)

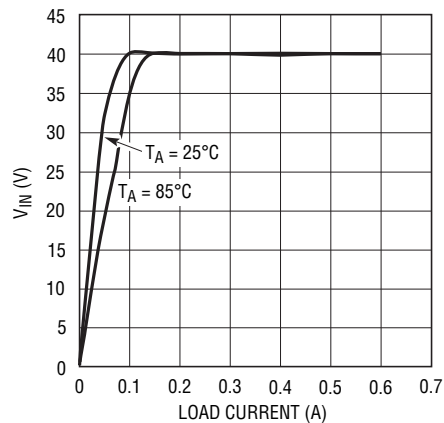

3502 G17

LT3502 Maximum V_{IN} for Full Frequency ($V_{OUT} = 3.3\text{V}$)

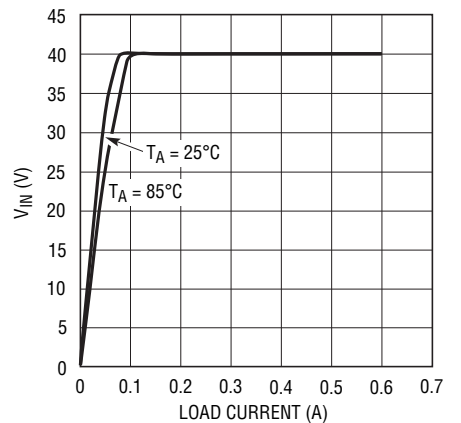

3502 G18

TYPICAL PERFORMANCE CHARACTERISTICS ($T_A = 25^\circ\text{C}$ unless otherwise noted)

LT3502A Typical Minimum Input Voltage ($V_{OUT} = 3.3\text{V}$)

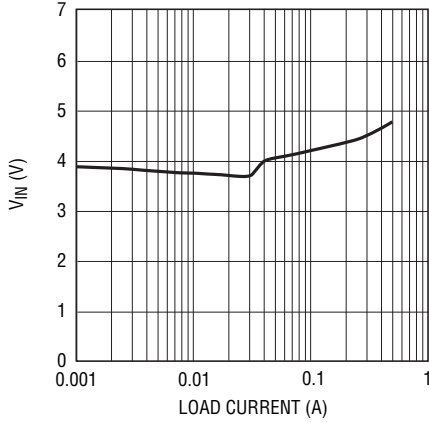

3502 G19

LT3502A Typical Minimum Input Voltage ($V_{OUT} = 5\text{V}$)

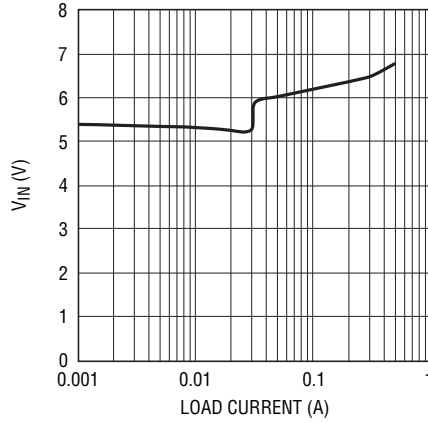

3502 G20

LT3502 Typical Minimum Input Voltage ($V_{OUT} = 3.3\text{V}$)

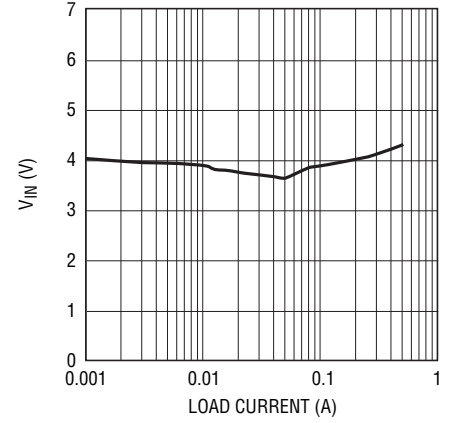

3502 G21

LT3502 Typical Minimum Input Voltage ($V_{OUT} = 5\text{V}$)

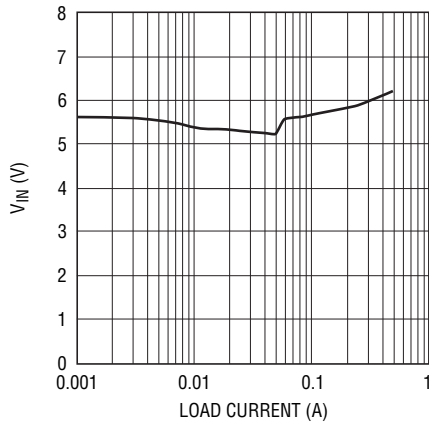

3502 G22

Continuous Mode Waveform

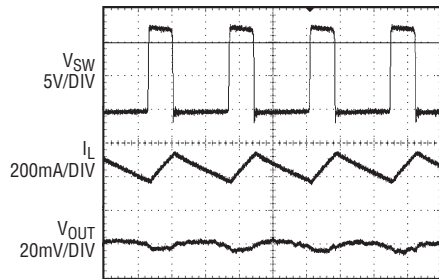

$V_{IN} = 12\text{V}$
 $V_{OUT} = 3.3\text{V}$
 $L = 6.8\mu\text{H}$
 $C_{OUT} = 10\mu\text{F}$
 $I_{OUT} = 250\text{mA}$

3502 G23

Discontinuous Mode Waveform

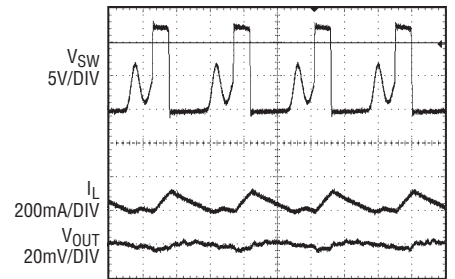

$V_{IN} = 12\text{V}$
 $V_{OUT} = 3.3\text{V}$
 $L = 6.8\mu\text{H}$
 $C_{OUT} = 10\mu\text{F}$
 $I_{OUT} = 30\text{mA}$

3502 G24

PIN FUNCTIONS (DFN/MS)

V_{IN} (Pin 1/Pin 10): The V_{IN} pin supplies current to the LT3502/LT3502A's internal regulator and to the internal power switch. This pin must be locally bypassed.

BD (Pin 2/Pin 8): The BD pin is used to provide current to the internal boost Schottky diode.

FB (Pin 3/Pin 7): The LT3502/LT3502A regulate their feedback pin to 0.8V. Connect the feedback resistor divider tap to this pin. Set the output voltage according to $V_{OUT} = 0.8 (1 + R1/R2)$. A good value for R2 is 10k.

SHDN (Pin 4/Pin 6): The SHDN pin is used to put the LT3502 in shutdown mode. Tie to ground to shut down the LT3502/LT3502A. Tie to 2V or more for normal operation. If the shutdown feature is not used, tie this pin to the V_{IN} pin. The SHDN pin also provides soft-start and frequency foldback. To use the soft-start feature, connect R3 and C4 to the SHDN pin. SHDN Pin voltage should not be higher than V_{IN}.

GND (Pin 5/Pin 5): Ground Pin.

DA (Pin 6/Pin 4): Connect the catch diode (D1) anode to this pin. This pin is used to provide frequency foldback in extreme situations.

BOOST (Pin 7/Pin 2): The BOOST pin is used to provide a drive voltage, higher than the input voltage, to the internal bipolar NPN power switch. Connect a boost capacitor from this pin to SW Pin.

SW (Pin 8/Pin 1): The SW pin is the output of the internal power switch. Connect this pin to the inductor, catch diode and boost capacitor.

BLOCK DIAGRAM

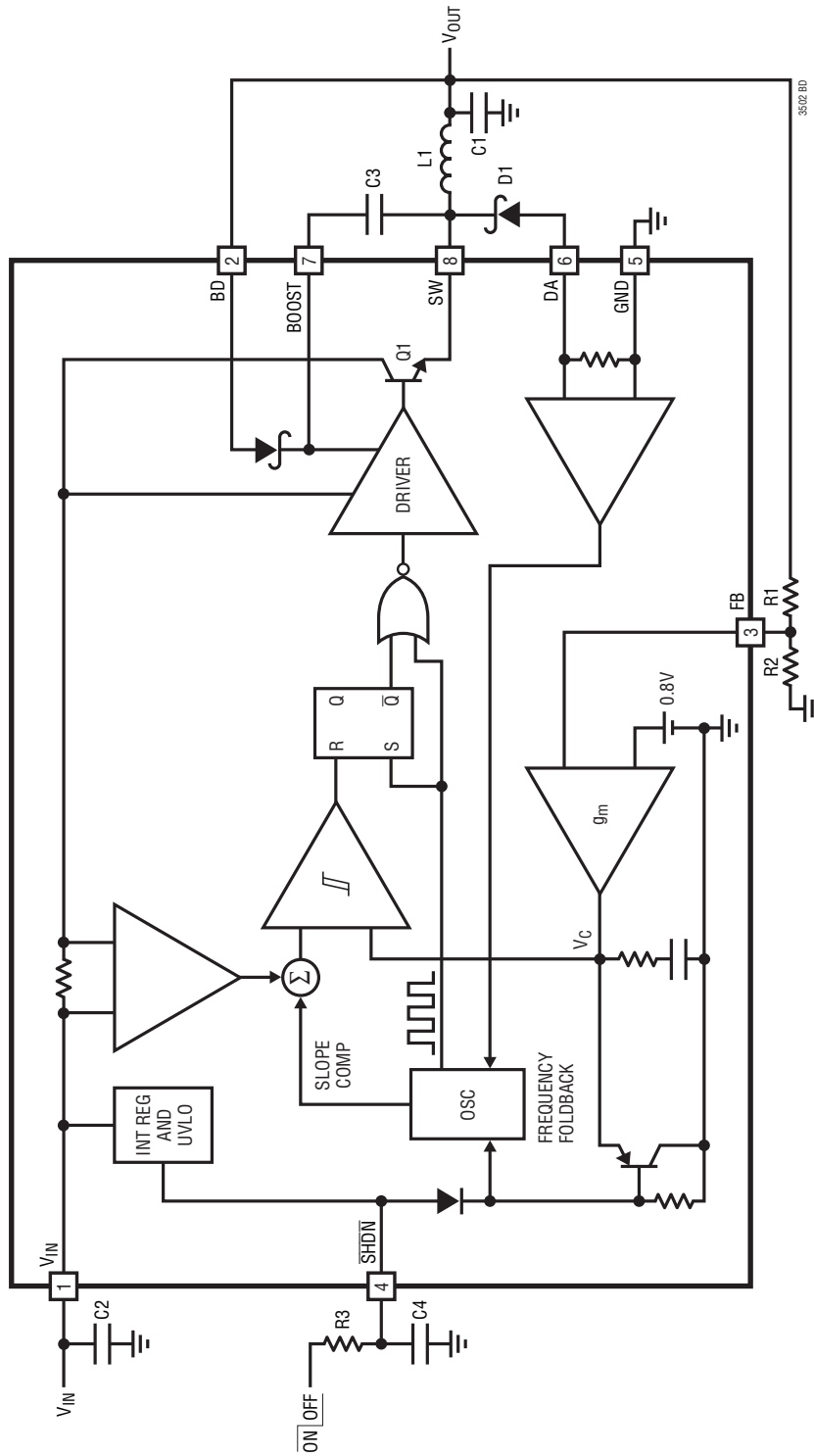

OPERATION

The LT3502/LT3502A are constant frequency, current mode step-down regulators. An oscillator enables an RS flip-flop, turning on the internal 500mA power switch Q1. An amplifier and comparator monitor the current flowing between the V_{IN} and SW pins, turning the switch off when this current reaches a level determined by the voltage at V_C . An error amplifier measures the output voltage through an external resistor divider tied to the FB pin and servos the V_C node. If the error amplifier's output increases, more current is delivered to the output; if it decreases, less current is delivered. An active clamp (not shown) on the V_C node provides current limit. The V_C node is also clamped to the voltage on the SHDN pin; soft-start is implemented by generating a voltage ramp at the $\overline{\text{SHDN}}$ pin using an external resistor and capacitor. The $\overline{\text{SHDN}}$ pin voltage during soft-start also reduces the oscillator frequency to avoid hitting current limit during start-up.

An internal regulator provides power to the control circuitry. This regulator includes an undervoltage lockout to prevent switching when V_{IN} is less than ~3V. The $\overline{\text{SHDN}}$ pin is used to place the LT3502/LT3502A in shutdown, disconnecting the output and reducing the input current to less than 2 μ A.

The switch driver operates from either V_{IN} or from the BOOST pin. An external capacitor and the internal diode are used to generate a voltage at the BOOST pin that is higher than the input supply. This allows the driver to fully saturate the internal bipolar NPN power switch for efficient operation.

A comparator monitors the current flowing through the catch diode via the DA pin and reduces the LT3502/LT3502A's operating frequency when the DA pin current exceeds the 650mA valley current limit. This frequency foldback helps to control the output current in fault conditions such as shorted output with high input voltage. The DA comparator works in conjunction with the switch peak current limit comparator to determine the maximum deliverable current of the LT3502/LT3502A. The peak current limit comparator is used in normal current mode operations and is used to turn off the switch. The DA valley current comparator monitors the catch diode current and will delay switching until the catch diode current is below the 650mA limit. Maximum deliverable current to the output is therefore limited by both switch peak current limit and DA valley current limit.

APPLICATIONS INFORMATION

FB Resistor Network

The output voltage is programmed with a resistor divider between the output and the FB pin. Choose the 1% resistors according to:

$$R1 = R2 \left(\frac{V_{OUT}}{0.8V} - 1 \right)$$

R2 should be 20k or less to avoid bias current errors. Reference designators refer to the Block Diagram.

Input Voltage Range

The input voltage range for the LT3502/LT3502A applications depends on the output voltage and on the absolute maximum ratings of the V_{IN} and BOOST pins.

The minimum input voltage is determined by either the LT3502/LT3502A's minimum operating voltage of 3V, or by its maximum duty cycle. The duty cycle is the fraction of time that the internal switch is on and is determined by the input and output voltages:

$$DC = \frac{V_{OUT} + V_D}{V_{IN} - V_{SW} + V_D}$$

where V_D is the forward voltage drop of the catch diode (~0.4V) and V_{SW} is the voltage drop of the internal switch (~0.45V at maximum load). This leads to a minimum input voltage of:

$$V_{IN(MIN)} = \frac{V_{OUT} + V_D}{DC_{MAX}} - V_D + V_{SW}$$

with $DC_{MAX} = 0.80$ for the LT3502A and 0.90 for the LT3502.

The maximum input voltage is determined by the absolute maximum ratings of the V_{IN} and BOOST pins. For fixed frequency operation, the maximum input voltage is determined by the minimum duty cycle DC_{MIN} :

$$V_{IN(MAX)} = \frac{V_{OUT} + V_D}{DC_{MIN}} - V_D + V_{SW}$$

$DC_{MIN} = 0.15$ for the LT3502A and 0.08 for the LT3502.

Note that this is a restriction on the operating input voltage for fixed frequency operation; the circuit will tolerate transient inputs up to the absolute maximum ratings of the V_{IN} and BOOST pins. The input voltage should be limited to the V_{IN} operating range (40V) during overload conditions.

Minimum On-Time

The LT3502/LT3502A will still regulate the output at input voltages that exceed $V_{IN(MAX)}$ (up to 40V), however, the output voltage ripple increases as the input voltage is increased.

As the input voltage is increased, the part is required to switch for shorter periods of time. Delays associated with turning off the power switch dictate the minimum on-time of the part. The minimum on-time for the LT3502/LT3502A is 60ns (Figure 1).

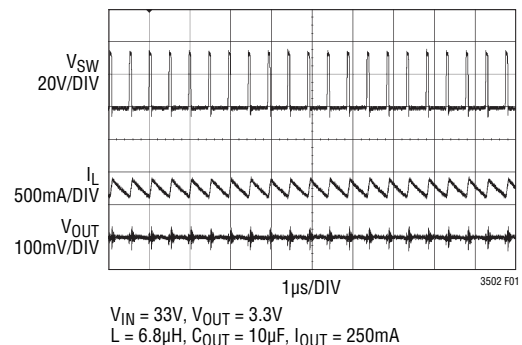

Figure 1. Continuous Mode Operation Near Minimum On-Time of 60ns

When the required on-time decreases below the minimum on-time of 60ns, instead of the switch pulse width becoming narrower to accommodate the lower duty cycle requirement, the switch pulse width remains fixed at 60ns. The inductor current ramps up to a value exceeding the load current and the output ripple increases. The part then remains off until the output voltage dips below the programmed value before it begins switching again (Figure 2).

Provided that the load can tolerate the increased output voltage ripple and that the components have been properly selected, operation above $V_{IN(MAX)}$ is safe and will not damage the part.

APPLICATIONS INFORMATION

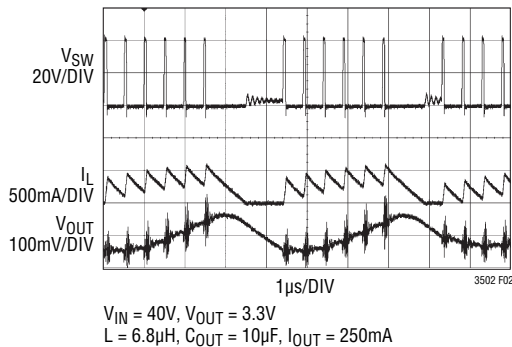

Figure 2. Pulse-Skipping Occurs when Required On-Time is Below 60ns

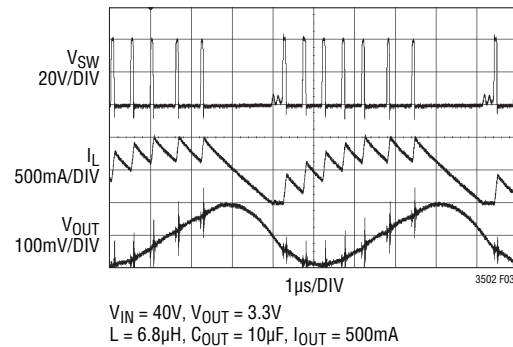

Figure 3. Pulse-Skipping with Large Load Current Will be Limited by the DA Valley Current Limit. Notice the Flat Inductor Valley Current and Reduced Switching Frequency

As the input voltage increases, the inductor current ramps up quicker, the number of skipped pulses increases and the output voltage ripple increases. For operation above $V_{IN(MAX)}$ the only component requirement is that the components be adequately rated for operation at the intended voltage levels.

Inductor current may reach current limit when operating in pulse-skipping mode with small valued inductors. In this case, the LT3502/LT3502A will periodically reduce its frequency to keep the inductor valley current to 650mA (Figure 3). Peak inductor current is therefore peak current plus minimum switch delay:

$$900mA + \frac{V_{IN} - V_{OUT}}{L} \cdot 60ns$$

The part is robust enough to survive prolonged operation under these conditions as long as the peak inductor current does not exceed 1.2A. Inductor current saturation and junction temperature may further limit performance during this operating regime.

Inductor Selection and Maximum Output Current

A good first choice for the inductor value is:

$$L = 1.6(V_{OUT} + V_D) \text{ for the LT3502A}$$

$$L = 4.6(V_{OUT} + V_D) \text{ for the LT3502}$$

where V_D is the voltage drop of the catch diode (~0.4V) and L is in μH . With this value there will be no subharmonic oscillation for applications with 50% or greater duty cycle. The inductor's RMS current rating must be greater than the maximum load current and its saturation current should be about 30% higher. For robust operation during fault conditions, the saturation current should be above 1.2A. To keep efficiency high, the series resistance (DCR) should be less than 0.1 Ω . Table 1 lists several vendors and types that are suitable.

There are several graphs in the Typical Performance Characteristics section of this data sheet that show the maximum load current as a function of input voltage and inductor value for several popular output voltages. Low inductance may result in discontinuous mode opera-

Table 1

VENDOR	URL	PART SERIES	INDUCTANCE RATE (μH)	SIZE (mm)
Sumida	www.sumida.com	CDRH4D28	1.2 to 4.7	4.5 x 4.5
		CDRH5D28	2.5 to 10	5.5 x 5.5
		CDRH8D28	2.5 to 33	8.3 x 8.3
Toko	www.toko.com	A916CY	2 to 12	6.3 x 6.2
		D585LC	1.1 to 39	8.1 x 8
Würth Elektronik	www.we-online.com	WE-TPC(M)	1 to 10	4.8 x 4.8
		WE-PD2(M)	2.2 to 22	5.2 x 5.8
		WE-PD(S)	1 to 27	7.3 x 7.3

APPLICATIONS INFORMATION

tion, which is okay, but further reduces maximum load current. For details of the maximum output current and discontinuous mode operation, see Linear Technology Application Note 44.

Catch Diode

A low capacitance 500mA Schottky diode is recommended for the catch diode, D1. The diode must have a reverse voltage rating equal to or greater than the maximum input voltage. The Diodes Inc. SBR1U40LP, ON Semi MBRM140, and Diodes Inc. DFSL140 are good choices for the catch diode.

Input Capacitor

Bypass the input of the LT3502/LT3502A circuit with a 1 μ F or higher value ceramic capacitor of X7R or X5R type. Y5V types have poor performance over temperature and applied voltage and should not be used. A 1 μ F ceramic is adequate to bypass the LT3502/LT3502A and will easily handle the ripple current. However, if the input power source has high impedance, or there is significant inductance due to long wires or cables, additional bulk capacitance may be necessary. This can be provided with a low performance electrolytic capacitor.

Step-down regulators draw current from the input supply in pulses with very fast rise and fall times. The input capacitor is required to reduce the resulting voltage ripple at the LT3502/LT3502A and to force this very high frequency switching current into a tight local loop, minimizing EMI. A 1 μ F capacitor is capable of this task, but only if it is placed close to the LT3502/LT3502A and the catch diode (see the PCB Layout section). A second precaution regarding the ceramic input capacitor concerns the maximum input voltage rating of the LT3502/LT3502A. A ceramic input capacitor combined with trace or cable inductance forms a high quality (underdamped) tank circuit. If the LT3502/LT3502A circuit is plugged into a live supply, the input voltage can ring to twice its nominal value, possibly exceeding the LT3502/LT3502A's voltage rating. This situation is easily avoided; see the Hot Plugging Safely section.

Output Capacitor

The output capacitor has two essential functions. Along with the inductor, it filters the square wave generated by the LT3502/LT3502A to produce the DC output. In this role it determines the output ripple so low impedance at the switching frequency is important. The second function is to store energy in order to satisfy transient loads and stabilize the LT3502/LT3502A's control loop. Ceramic capacitors have very low equivalent series resistance (ESR) and provide the best ripple performance. A good value is:

$$C_{OUT} = \frac{33}{V_{OUT}} \text{ for the LT3502A}$$

$$C_{OUT} = \frac{66}{V_{OUT}} \text{ for the LT3502}$$

where C_{OUT} is in μ F. Use an X5R or X7R type and keep in mind that a ceramic capacitor biased with V_{OUT} will have less than its nominal capacitance. This choice will provide low output ripple and good transient response. Transient performance can be improved with a high value capacitor, but a phase lead capacitor across the feedback resistor, R1, may be required to get the full benefit (see the Compensation section).

For small size, the output capacitor can be chosen according to:

$$C_{OUT} = \frac{25}{V_{OUT}}$$

where C_{OUT} is in μ F. However, using an output capacitor this small results in an increased loop crossover frequency and increased sensitivity to noise.

High performance electrolytic capacitors can be used for the output capacitor. Low ESR is important, so choose one that is intended for use in switching regulators. The ESR should be specified by the supplier and should be 0.1 Ω or less. Such a capacitor will be larger than a ceramic capacitor and will have a larger capacitance, because the capacitor must be large to achieve low ESR. Table 2 lists several capacitor vendors.

APPLICATIONS INFORMATION

Table 2

VENDOR	PHONE	URL	PART SERIES	COMMENTS
Panasonic	(714) 373-7366	www.panasonic.com	Ceramic Polymer, Tantalum	EEF Series
Kemet	(864) 963-6300	www.kemet.com	Ceramic, Tantalum	T494, T495
Sanyo	(408) 794-9714	www.sanyovideo.com	Ceramic Polymer, Tantalum	POSCAP
Murata	(404) 436-1300	www.murata.com	Ceramic	
AVX		www.avxcorp.com	Ceramic, Tantalum	TPS Series
Taiyo Yuden	(864) 963-6300	www.taiyo-yuden.com	Ceramic	

Figure 4 shows the transient response of the LT3502A with several output capacitor choices. The output is 3.3V. The load current is stepped from 150mA to 400mA and back to 150mA, and the oscilloscope traces show the output voltage. The upper photo shows the recommended value. The second photo shows the improved response (less voltage drop) resulting from a larger output capacitor and a phase lead capacitor. The last photo shows the response to a high performance electrolytic capacitor. Transient performance is improved due to the large output capacitance.

BOOST Pin Considerations

Capacitor C3 and the internal boost diode are used to generate a boost voltage that is higher than the input voltage. In most cases a 0.1µF capacitor will work well. Figure 5 shows two ways to arrange the boost circuit. The BOOST pin must be at least 2.2V above the SW pin for best efficiency. For outputs of 3V and above, the standard circuit (Figure 5a) is best. For outputs less than 3V and above 2.5V, place a discrete Schottky diode (such as the BAT54) in parallel with the internal diode to reduce V_D . The following equations can be used to calculate and minimize boost capacitance in µF:

$$0.012 / (V_{BD} + V_{CATCH} - V_D - 2.2) \text{ for the LT3502A}$$

$$0.030 / (V_{BD} + V_{CATCH} - V_D - 2.2) \text{ for the LT3502}$$

V_D is the forward drop of the boost diode, and V_{CATCH} is the forward drop of the catch diode (D1).

For lower output voltages the BD pin can be tied to an external voltage source with adequate local bypassing

(Figure 5b). The above equations still apply for calculating the optimal boost capacitor for the chosen BD voltage. The absence of BD voltage during start-up will increase minimum voltage to start and reduce efficiency. You must also be sure that the maximum voltage rating of BOOST pin is not exceeded.

The minimum operating voltage of an LT3502/LT3502A application is limited by the undervoltage lockout (3V) and by the maximum duty cycle as outlined above. For proper start-up, the minimum input voltage is also limited by the boost circuit. If the input voltage is ramped slowly, or the LT3502/LT3502A is turned on with its SHDN pin when the output is already in regulation, then the boost capacitor may not be fully charged. Because the boost capacitor is charged with the energy stored in the inductor, the circuit will rely on some minimum load current to get the boost circuit running properly. This minimum load will depend on the input and output voltages, and on the arrangement of the boost circuit. The minimum load generally goes to zero once the circuit has started. Figure 6 shows plots of minimum load to start and to run as a function of input voltage. In many cases the discharged output capacitor will present a load to the switcher which will allow it to start. The plots show the worst-case situation where V_{IN} is ramping very slowly. At light loads, the inductor current becomes discontinuous and the effective duty cycle can be very high. This reduces the minimum input voltage to approximately 400mV above V_{OUT} . At higher load currents, the inductor current is continuous and the duty cycle is limited by the maximum duty cycle of the LT3502/LT3502A, requiring a higher input voltage to maintain regulation.

APPLICATIONS INFORMATION

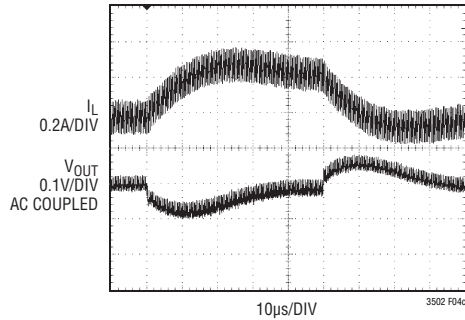
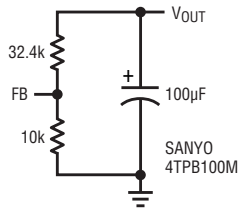
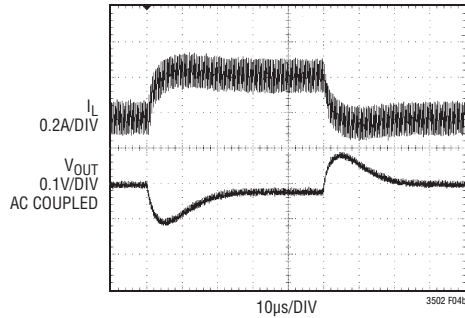
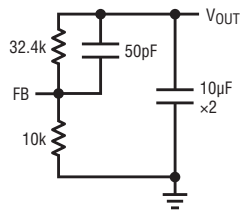
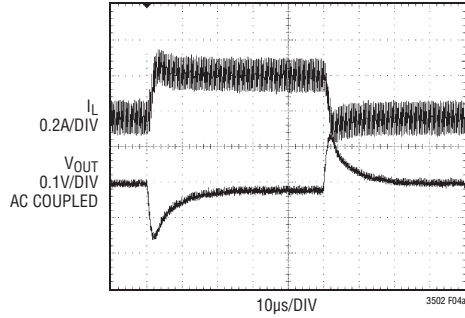
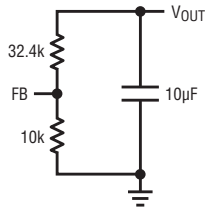
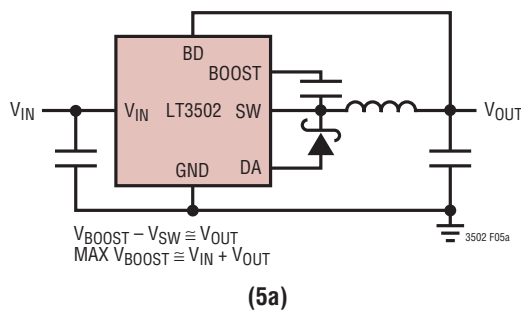
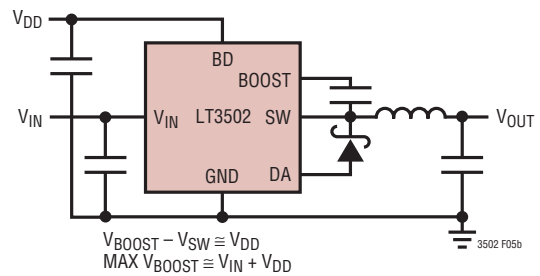

Figure 4. Transient Load Response of the LT3502A with Different Output Capacitors as the Load Current is Stepped from 150mA to 400mA. V_{IN} = 12V, V_{OUT} = 3.3V, L = 6.8µH



(5a)



(5b)

Figure 5

APPLICATIONS INFORMATION

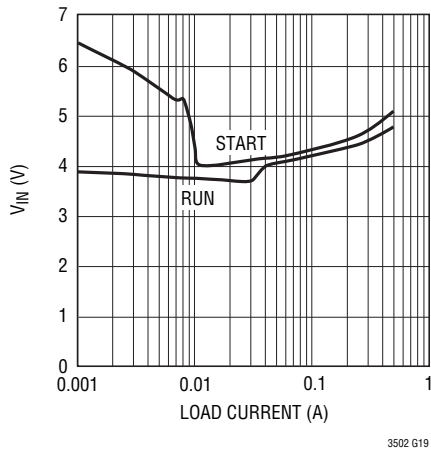

(6a) LT3502A Typical Minimum Input Voltage, $V_{OUT} = 3.3V$

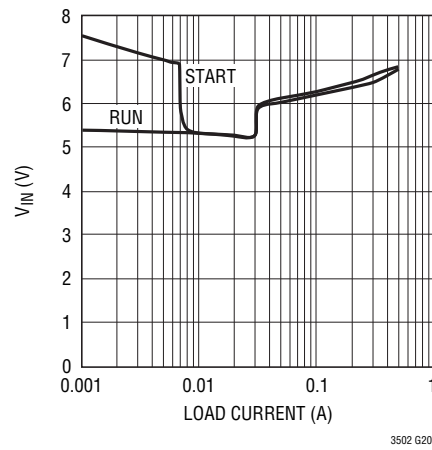

(6b) LT3502A Typical Minimum Input Voltage, $V_{OUT} = 5V$

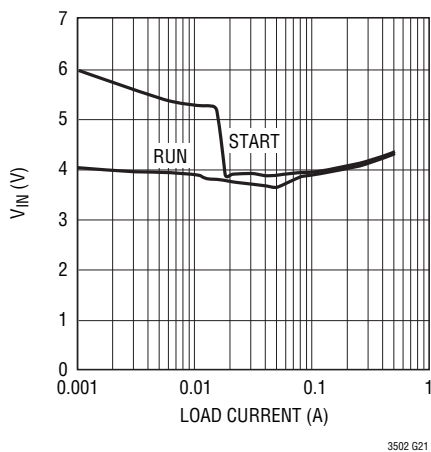

(6c) LT3502 Typical Minimum Input Voltage, $V_{OUT} = 3.3V$

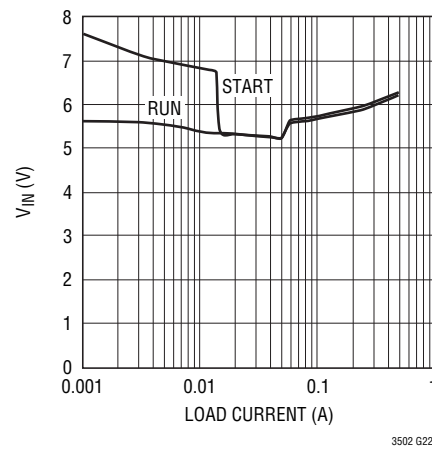

(6d) LT3502 Typical Minimum Input Voltage, $V_{OUT} = 5V$

Figure 6

Soft-Start

The \overline{SHDN} pin can be used to soft start the LT3502/LT3502A, reducing the maximum input current during start-up. The \overline{SHDN} pin is driven through an external RC filter to create a voltage ramp at this pin. Figure 7 shows the start-up waveforms with and without the soft-start circuit. By choosing a large RC time constant, the peak start-up current can be reduced to the current that is required to regulate the output, with no overshoot. Choose the value of the resistor so that it can supply $80\mu A$ when the \overline{SHDN} pin reaches 2V.

Short and Reverse Protection

If the inductor is chosen so that it won't saturate excessively, the LT3502/LT3502A will tolerate a shorted output. When operating in short-circuit condition, the LT3502/LT3502A will reduce their frequency until the valley current is 650mA (Figure 8a). There is another situation to consider in systems where the output will be held high when the input to the LT3502/LT3502A is absent. This may occur in battery charging applications or in battery backup systems where a battery or some other supply is diode OR-ed with the LT3502/LT3502A's output. If the V_{IN} pin is allowed to float and the \overline{SHDN} pin is held high (either by a logic signal

APPLICATIONS INFORMATION

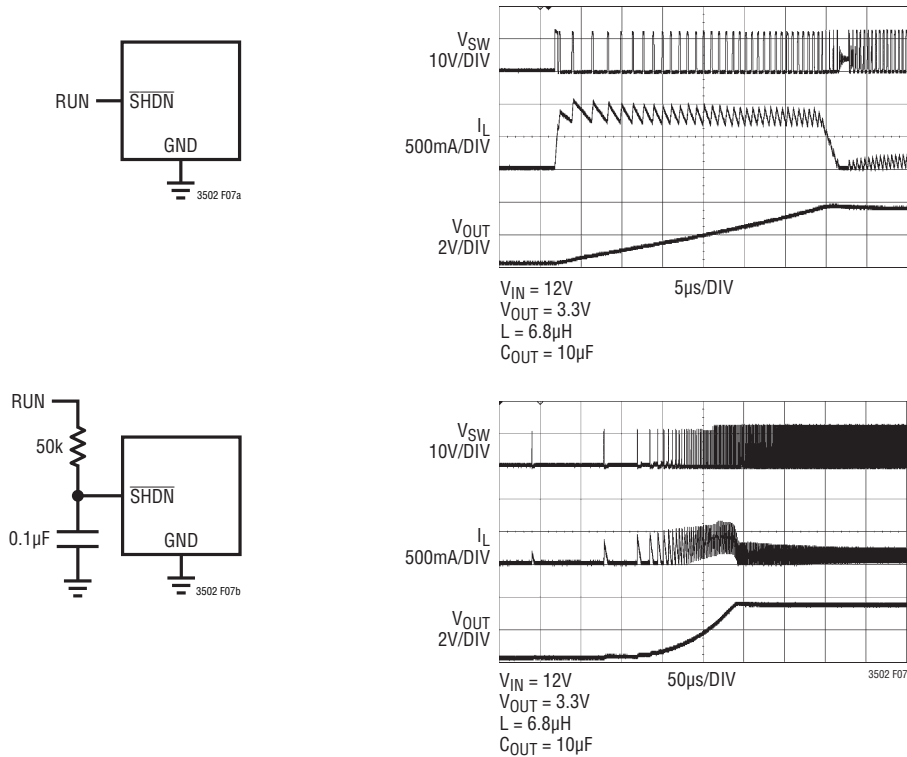

Figure 7. To Soft-Start the LT3502A, Add a Resistor and Capacitor to the $\overline{\text{SHDN}}$ Pin

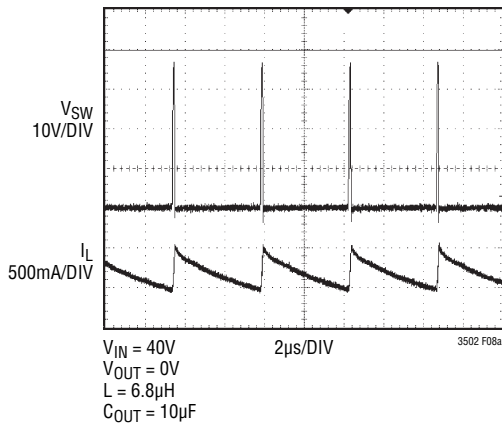

Figure 8a. The LT3502A Reduces its Frequency to Below 500kHz to Protect Against Shorted Output with 40V Input

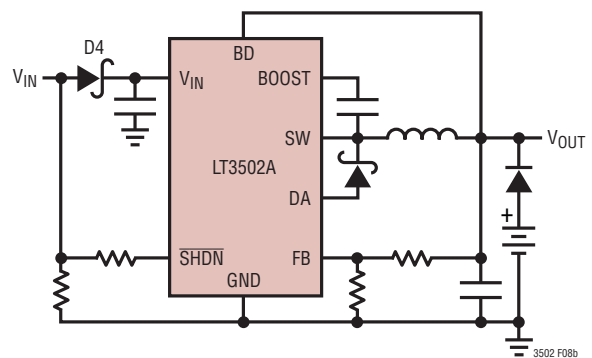

Figure 8b. Diode D4 Prevents a Shorted Input from Discharging a Backup Battery Tied to the Output; it Also Protects the Circuit from a Reversed Input. The LT3502/LT3502A Runs Only When the Input is Present

APPLICATIONS INFORMATION

or because it is tied to V_{IN}), then the LT3502/LT3502A's internal circuitry will pull its quiescent current through its SW pin. This is fine if your system can tolerate a few mA in this state. If you ground the SHDN pin, the SW pin current will drop to essentially zero. However, if the V_{IN} pin is grounded while the output is held high, then parasitic diodes inside the LT3502/LT3502A can pull large currents from the output through the SW pin and the V_{IN} pin. Figure 8b shows a circuit that will run only when the input voltage is present and that protects against a shorted or reversed input.

Hot Plugging Safely

The small size, robustness and low impedance of ceramic capacitors make them an attractive option for the input bypass capacitor of LT3502/LT3502A circuits. However, these capacitors can cause problems if the LT3502/LT3502A

are plugged into a live supply (see Linear Technology Application Note 88 for a complete discussion). The low loss ceramic capacitor combined with stray inductance in series with the power source forms an underdamped tank circuit, and the voltage at the V_{IN} pin of the LT3502/LT3502A can ring to twice the nominal input voltage, possibly exceeding the LT3502/LT3502A's rating and damaging the part. If the input supply is poorly controlled or the user will be plugging the LT3502/LT3502A into an energized supply, the input network should be designed to prevent this overshoot. Figure 9 shows the waveforms that result when an LT3502/LT3502A circuit is connected to a 24V supply through six feet of 24-gauge twisted pair. The first plot is the response with a 2.2 μ F ceramic capacitor at the input. The input voltage rings as high as 35V and the input current peaks at 20A. One method of damping the tank circuit is to add another capacitor with a series resistor to

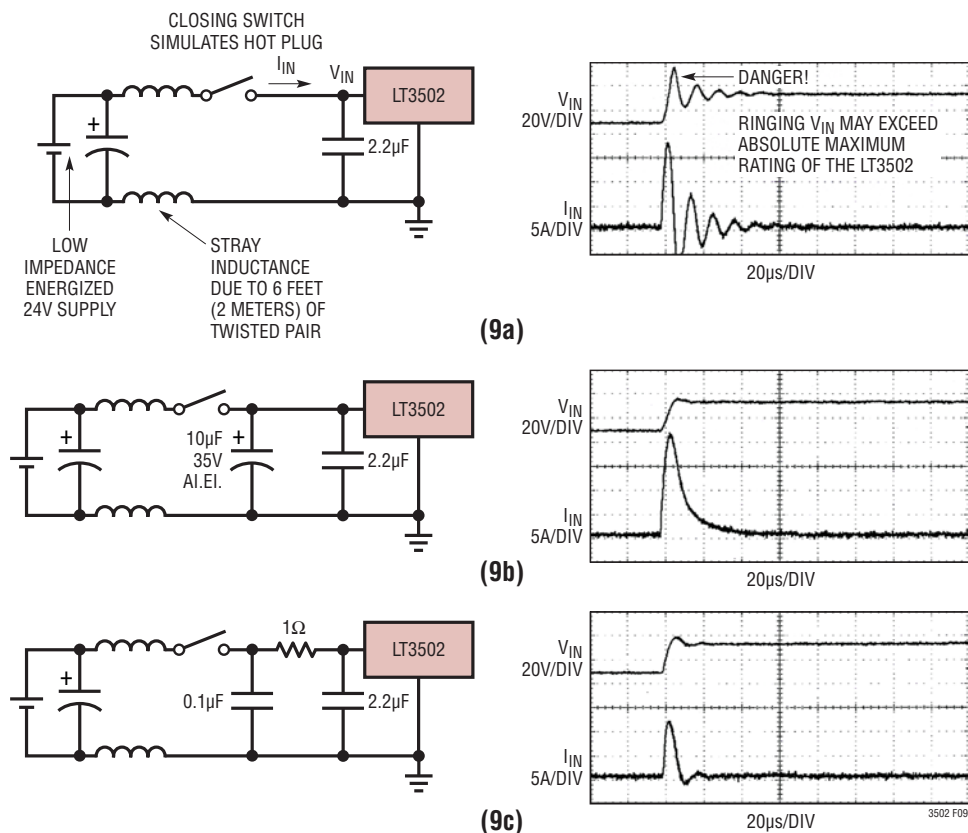

Figure 9. A Well Chosen Input Network Prevents Input Voltage Overshoot and Ensures Reliable Operation When the LT3502 is Connected to a Live Supply

APPLICATIONS INFORMATION

the circuit. In Figure 9b an aluminum electrolytic capacitor has been added. This capacitor's high equivalent series resistance damps the circuit and eliminates the voltage overshoot. The extra capacitor improves low frequency ripple filtering and can slightly improve the efficiency of the circuit, though it is likely to be the largest component in the circuit. An alternative solution is shown in Figure 9c. A 1Ω resistor is added in series with the input to eliminate the voltage overshoot (it also reduces the peak input current). A 0.1μF capacitor improves high frequency filtering. This solution is smaller and less expensive than the electrolytic capacitor. For high input voltages its impact on efficiency is minor, reducing efficiency less than one half percent for a 5V output at full load operating from 24V.

Frequency Compensation

The LT3502/LT3502A use current mode control to regulate the output. This simplifies loop compensation. In particular, the LT3502/LT3502A does not require the ESR of the output capacitor for stability allowing the use of ceramic capacitors to achieve low output ripple and small circuit size.

Figure 10 shows an equivalent circuit for the LT3502/LT3502A control loop. The error amp is a transconductance amplifier with finite output impedance. The power section, consisting of the modulator, power switch and inductor, is modeled as a transconductance amplifier generating an output current proportional to the voltage at the V_C node. Note that the output capacitor integrates this current,

and that the capacitor on the V_C node (C_C) integrates the error amplifier output current, resulting in two poles in the loop. R_C provides a zero. With the recommended output capacitor, the loop crossover occurs above the $R_C C_C$ zero. This simple model works well as long as the value of the inductor is not too high and the loop crossover frequency is much lower than the switching frequency. With a larger ceramic capacitor (very low ESR), crossover may be lower and a phase lead capacitor (C_{PL}) across the feedback divider may improve the phase margin and transient response. Large electrolytic capacitors may have an ESR large enough to create an additional zero, and the phase lead may not be necessary.

If the output capacitor is different than the recommended capacitor, stability should be checked across all operating conditions, including load current, input voltage and temperature. The LT1375 data sheet contains a more thorough discussion of loop compensation and describes how to test the stability using a transient load.

PCB Layout

For proper operation and minimum EMI, care must be taken during printed circuit board layout. Figure 11 shows the recommended component placement with trace, ground plane and via locations. Note that large, switched currents flow in the LT3502/LT3502A's V_{IN} and SW pins, the catch diode (D1) and the input capacitor (C2).

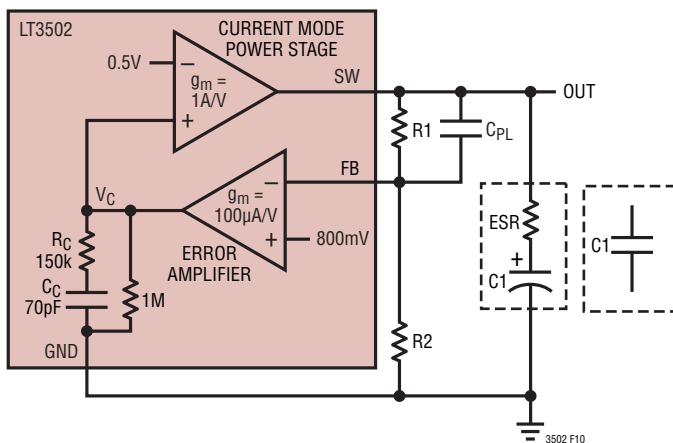

Figure 10. Model for Loop Response

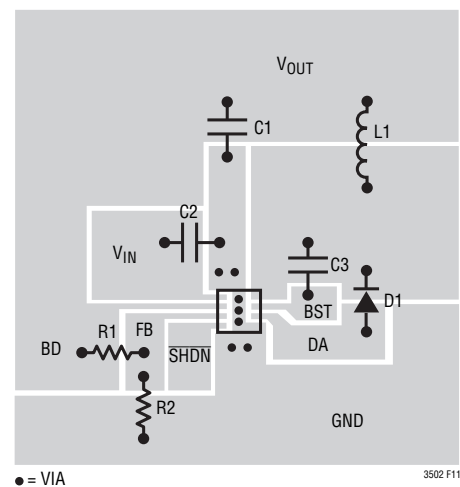

Figure 11

APPLICATIONS INFORMATION

The loop formed by these components should be as small as possible and tied to system ground in only one place. These components, along with the inductor and output capacitor, should be placed on the same side of the circuit board, and their connections should be made on that layer. Place a local, unbroken ground plane below these components, and tie this ground plane to system ground at one location, ideally at the ground terminal of the output capacitor C1. The SW and BOOST nodes should be as small as possible. Finally, keep the FB node small so that the ground pin and ground traces will shield it from the SW and BOOST nodes. Include vias near the exposed GND pad of the LT3502/LT3502A to help remove heat from the LT3502/LT3502A to the ground plane.

High Temperature Considerations

The die temperature of the LT3502/LT3502A must be lower than the maximum rating of 125°C. This is generally not a concern unless the ambient temperature is above 85°C. For higher temperatures, care should be taken in the layout of the circuit to ensure good heat sinking of the LT3502/LT3502A. The maximum load current should be derated as the ambient temperature approaches 125°C. The die temperature is calculated by multiplying the LT3502/LT3502A power dissipation by the thermal resistance from junction to ambient. Power dissipation within the LT3502/LT3502A can be estimated by calculating the total power loss from an efficiency measurement and subtracting the catch diode loss. Thermal resistance depends on the layout of the circuit board, but 102°C/W and 110°C/W are typical for the (2mm × 2mm) DFN and MS10 packages respectively.

Outputs Greater Than 7V

Note that for outputs above 7V, the input voltage range will be limited by the maximum rating of the BOOST pin. The sum of input and output voltages cannot exceed the BOOST pin's 50V rating. The 15V circuit (Figure 12) shows how to overcome this limitation using an additional Zener diode.

Other Linear Technology Publications

Application Notes AN19, AN35 and AN44 contain more detailed descriptions and design information for Buck regulators and other switching regulators. The LT1376 data sheet has a more extensive discussion of output ripple, loop compensation and stability testing. Design Note 100 shows how to generate a bipolar output supply using a buck regulator.

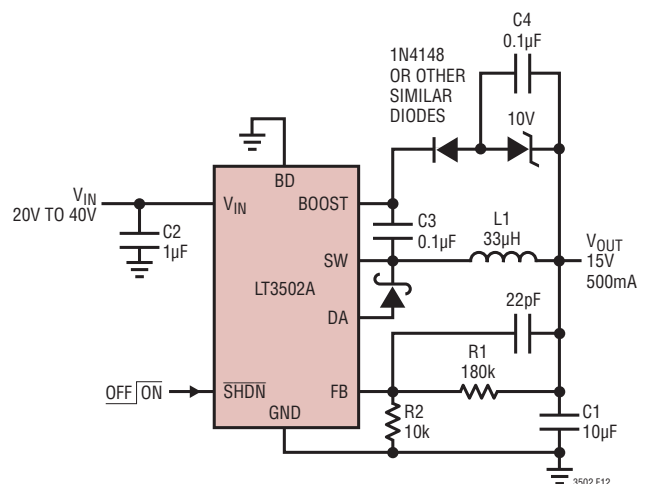
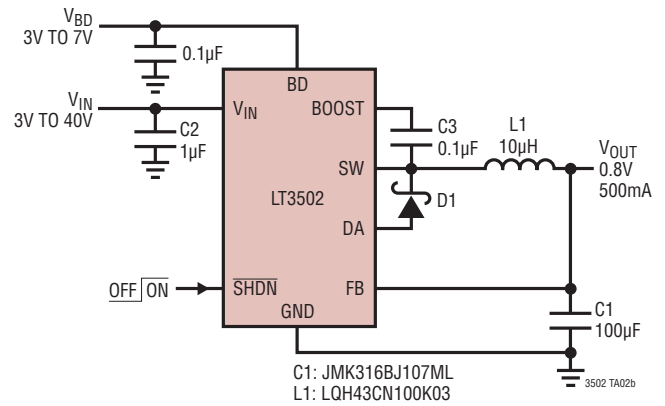
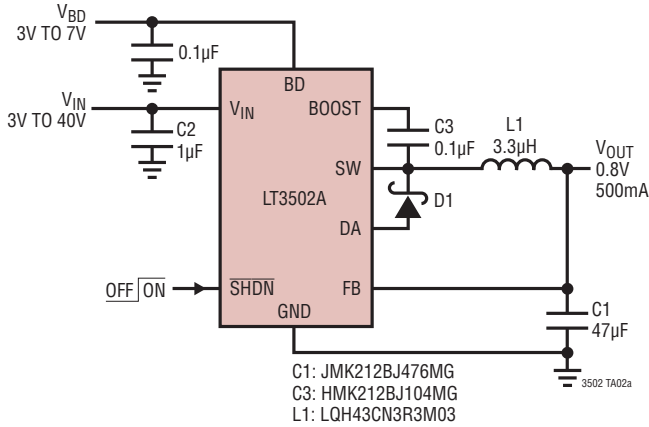

Figure 12. 15V Step-Down Converter

TYPICAL APPLICATIONS

0.8V Step-Down Converter



1.8V Step-Down Converter

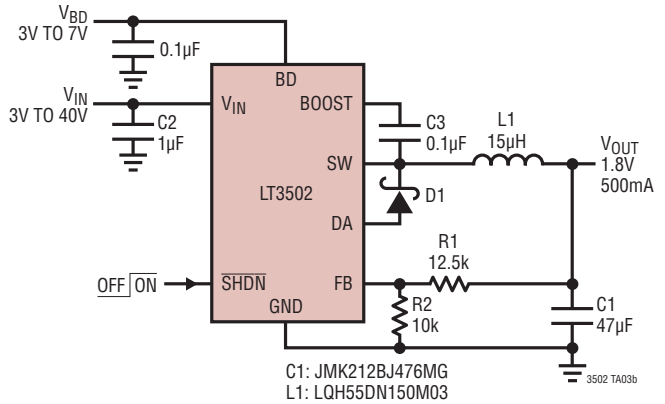
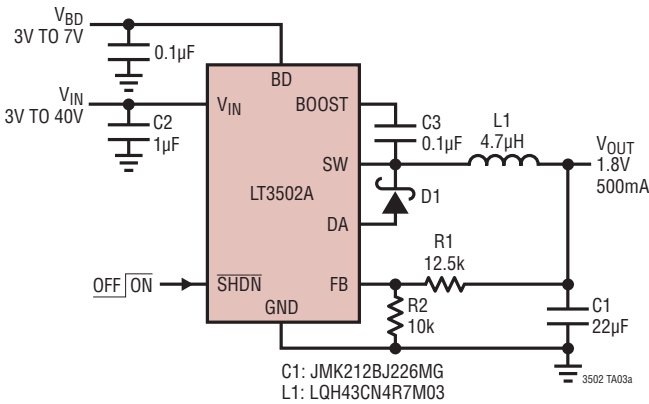

TYPICAL APPLICATIONS

2.5V Step-Down Converter

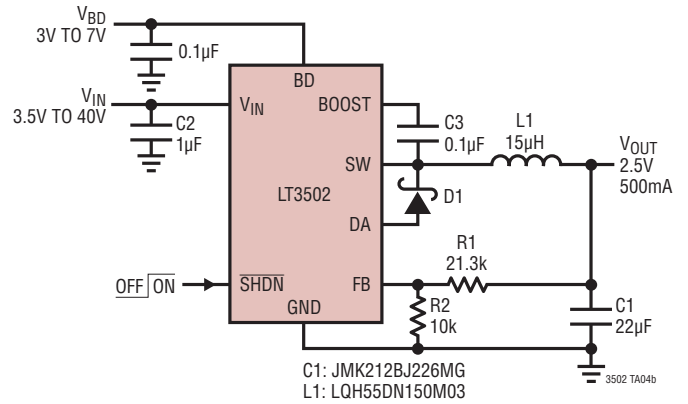
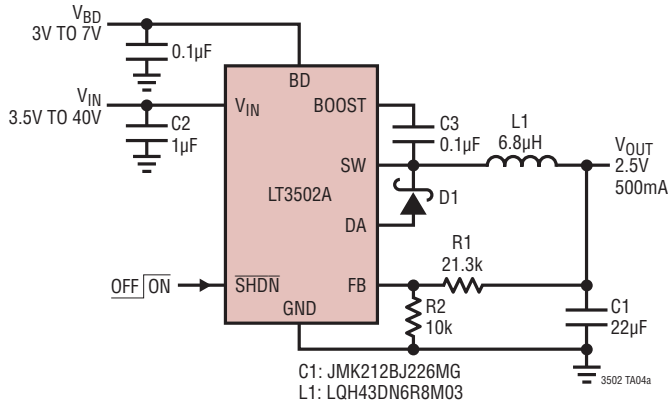

3.3V Step-Down Converter

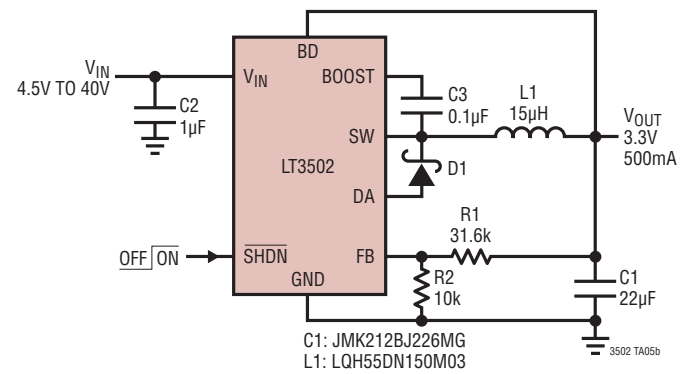
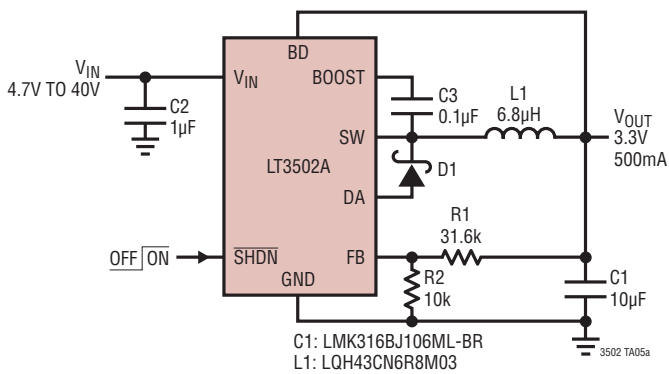

PACKAGE DESCRIPTION

DC8 Package
8-Lead Plastic DFN (2mm × 2mm)
 (Reference LTC DWG # 05-08-1719 Rev A)

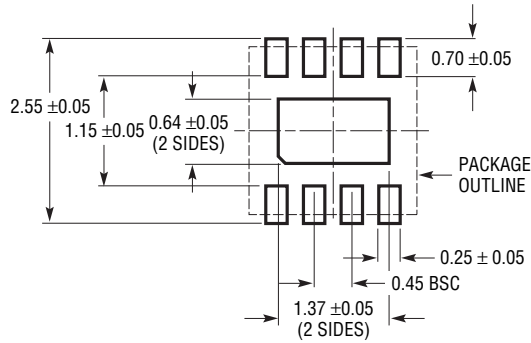

RECOMMENDED SOLDER PAD PITCH AND DIMENSIONS
 APPLY SOLDER MASK TO AREAS THAT ARE NOT SOLDERED

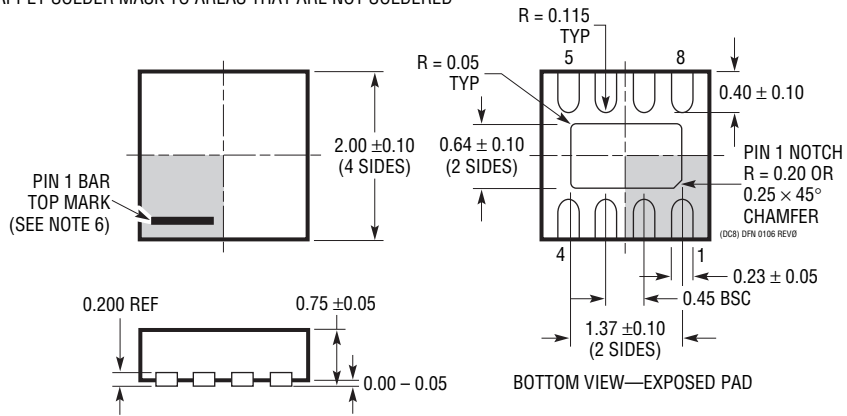

- NOTE:
1. DRAWING IS NOT A JEDEC PACKAGE OUTLINE
 2. DRAWING NOT TO SCALE
 3. ALL DIMENSIONS ARE IN MILLIMETERS
 4. DIMENSIONS OF EXPOSED PAD ON BOTTOM OF PACKAGE DO NOT INCLUDE MOLD FLASH. MOLD FLASH, IF PRESENT, SHALL NOT EXCEED 0.15mm ON ANY SIDE
 5. EXPOSED PAD SHALL BE SOLDER PLATED
 6. SHADED AREA IS ONLY A REFERENCE FOR PIN 1 LOCATION ON THE TOP AND BOTTOM OF PACKAGE

PACKAGE DESCRIPTION

MS Package 10-Lead Plastic MSOP

(Reference LTC DWG # 05-08-1661 Rev E)

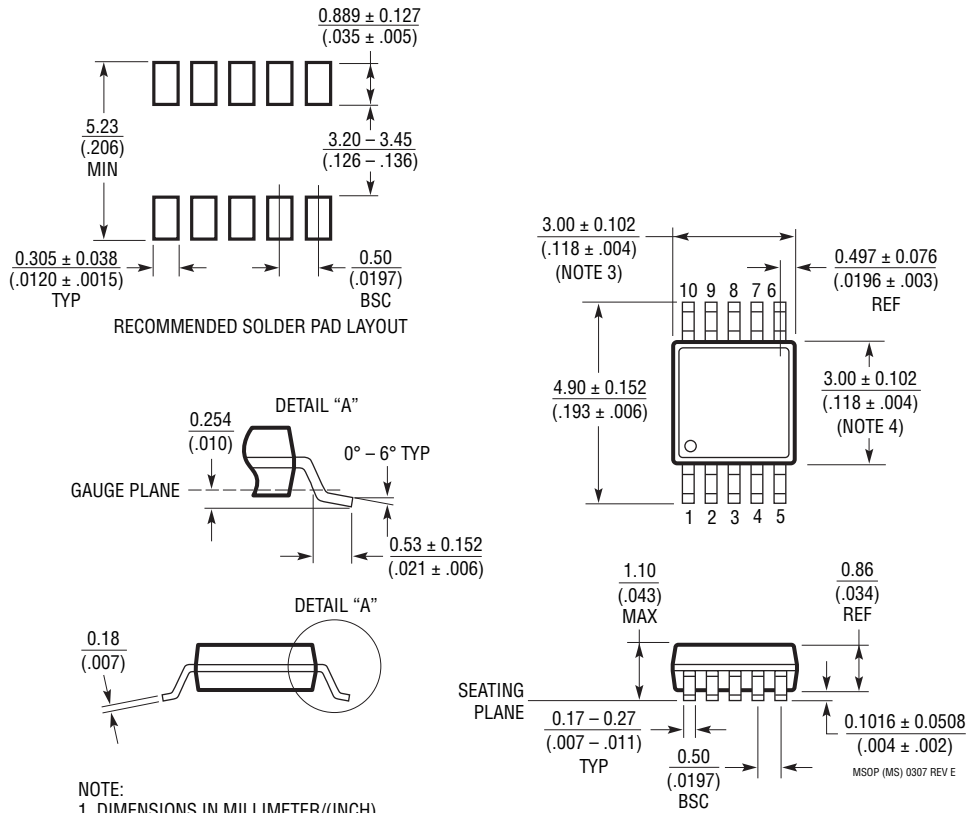

- NOTE:
1. DIMENSIONS IN MILLIMETER/(INCH)
 2. DRAWING NOT TO SCALE
 3. DIMENSION DOES NOT INCLUDE MOLD FLASH, PROTRUSIONS OR GATE BURRS.
MOLD FLASH, PROTRUSIONS OR GATE BURRS SHALL NOT EXCEED 0.152mm (.006") PER SIDE
 4. DIMENSION DOES NOT INCLUDE INTERLEAD FLASH OR PROTRUSIONS.
INTERLEAD FLASH OR PROTRUSIONS SHALL NOT EXCEED 0.152mm (.006") PER SIDE
 5. LEAD COPLANARITY (BOTTOM OF LEADS AFTER FORMING) SHALL BE 0.102mm (.004") MAX

LT3502/LT3502A

TYPICAL APPLICATION

5V Step-Down Converter

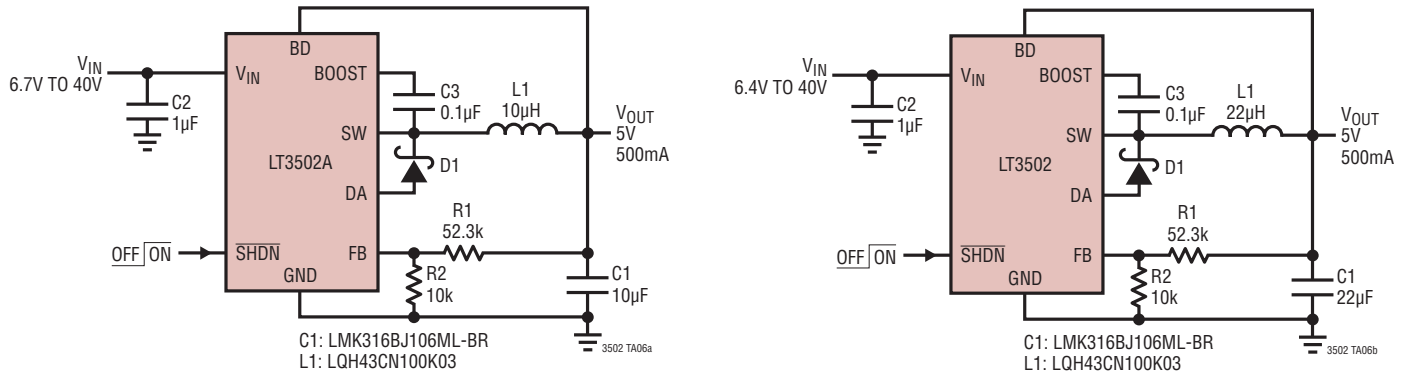

RELATED PARTS

PART NUMBER	DESCRIPTION	COMMENTS
LT1766	60V, 1.2A (I_{OUT}), 200kHz, High Efficiency Step-Down DC/DC Converter	V_{IN} : 5.5V to 60V, $V_{OUT(MIN)}$ = 1.2V, I_Q = 2.5mA, I_{SD} = 25µA, TSSOP16/TSSOP16E Packages
LT1933	500mA (I_{OUT}), 500kHz, Step-Down Switching Regulator in SOT-23	V_{IN} : 3.6V to 36V, $V_{OUT(MIN)}$ = 1.2V, I_Q = 1.6mA, I_{SD} < 1µA, ThinSOT™ Package
LT1936	36V, 1.4A (I_{OUT}), 500kHz, High Efficiency Step-Down DC/DC Converter	V_{IN} : 3.6V to 36V, $V_{OUT(MIN)}$ = 1.2V, I_Q = 1.9mA, I_{SD} < 1µA, MS8E Package
LT1940	Dual 25V, 1.4A (I_{OUT}), 1.1MHz, High Efficiency Step-Down DC/DC Converter	V_{IN} : 3.6V to 25V, $V_{OUT(MIN)}$ = 1.20V, I_Q = 3.8mA, I_{SD} < 30µA, TSSOP16E Package
LT1976/ LT1977	60V, 1.2A (I_{OUT}), 200kHz/500kHz High Efficiency Step-Down DC/DC Converters with Burst Mode® Operation	V_{IN} : 3.3V to 60V, $V_{OUT(MIN)}$ = 1.20V, I_Q = 100µA, I_{SD} < 1µA, TSSOP16E Package
LTC3407/ LTC3407-2	Dual 600mA/800mA, 1.5MHz/2.25MHz, Synchronous Step-Down DC/DC Converters	V_{IN} : 2.5V to 5.5V, $V_{OUT(MIN)}$ = 0.6V, I_Q = 40µA, I_{SD} < 1µA, 3mm × 3mm DFN, MS10E Package
LT3434/ LT3435	60V, 1.2A (I_{OUT}), 200kHz/500kHz High Efficiency Step-Down DC/DC Converters with Burst Mode Operation	V_{IN} : 3.3V to 60V, $V_{OUT(MIN)}$ = 1.20V, I_Q = 100µA, I_{SD} < 1µA, TSSOP16E Package
LT3437	60V, 400mA (I_{OUT}), Micropower Step-Down DC/DC Converter with Burst Mode Operation	V_{IN} : 3.3V to 60V, $V_{OUT(MIN)}$ = 1.25V, I_Q = 100µA, I_{SD} < 1µA, DFN Package
LT3493	36V, 1.4A (I_{OUT}), 750kHz, High Efficiency Step-Down DC/DC Converter	V_{IN} : 3.6V to 36V, $V_{OUT(MIN)}$ = 0.8V, I_Q = 1.9mA, I_{SD} < 1µA, DFN Package
LT3501	Dual 25V, 3A (I_{OUT}), 1.5MHz, High Efficiency Step-Down DC/DC Converter	V_{IN} : 3.3V to 25V, $V_{OUT(MIN)}$ = 0.8V, I_Q = 3.7mA, I_{SD} < 10µA, TSSOP20E Package
LT3503	20V, 1A (I_{OUT}), 2.2MHz, High Efficiency Step-Down DC/DC Converter	V_{IN} : 3.6V to 20V, $V_{OUT(MIN)}$ = 0.78V, I_Q = 1.9mA, I_{SD} < 1µA, 2mm × 3mm DFN Package
LT3505	36V, 1.2A (I_{OUT}), 3MHz, High Efficiency Step-Down DC/DC Converter	V_{IN} : 3.6V to 36V, $V_{OUT(MIN)}$ = 0.78V, I_Q = 2mA, I_{SD} < 2µA, 3mm × 3mm DFN, MS8E Packages
LT3506/ LT3506A	Dual 25V, 1.6A (I_{OUT}), 575kHz/1.1MHz, High Efficiency Step-Down DC/DC Converters	V_{IN} : 3.6V to 25V, $V_{OUT(MIN)}$ = 0.8V, I_Q = 3.8mA, I_{SD} < 30µA, 4mm × 5mm DFN Package
LT3508	Dual 36V, 1.4A (I_{OUT}), 2.5MHz, High Efficiency Step-Down DC/DC Converter	V_{IN} : 3.6V to 36V, $V_{OUT(MIN)}$ = 0.8V, I_Q = 4.3mA, I_{SD} < 1µA, 4mm × 4mm QFN, TSSOP16E Packages
LT3510	Dual 25V, 2A (I_{OUT}), 1.5MHz, High Efficiency Step-Down DC/DC Converter	V_{IN} : 3.3V to 25V, $V_{OUT(MIN)}$ = 0.8V, I_Q = 3.7mA, I_{SD} < 10µA, TSSOP20E Package
LTC3548	Dual 400mA + 800mA, 2.25MHz Synchronous Step-Down DC/DC Converter	V_{IN} : 2.5V to 5.5V, $V_{OUT(MIN)}$ = 0.6V, I_Q = 40µA, I_{SD} < 1µA, 3mm × 3mm DFN, MS10E Packages

Burst Mode is a registered trademark of Linear Technology Corporation. ThinSOT is a trademark of Linear Technology Corporation.

3502fd

Looking for pricing, stock, or lifecycle information?

Click below to explore more details on WIN SOURCE:

 [View LT3502IMS#PBF on WIN SOURCE](#)

 [Linear Technology](#) Information

Optimize Your Supply Chain with WIN SOURCE Solutions

-  Global Sourcing Solution
-  Obsolete Management
-  Cost Control Management
-  Shortage Management
-  Alternative Solution
-  Excess Inventory Management