



**THE DATASHEET OF
LT3599EUH#PBF**



4-String 120mA LED Driver with $\pm 1.5\%$ Current Matching

FEATURES

- True Color PWM™ Dimming Ratio Up to 3000:1
- Drives Four Strings of LEDs at Up to 120mA
- $\pm 1.5\%$ Accurate LED Current Matching
- Wide Input Voltage Range: 3.1V to 30V
- Output Voltage Up to 44V
- Regulates LED Current Even When $V_{IN} > V_{OUT}$
- Disconnects LEDs in Shutdown
- Programmable Maximum V_{OUT} (Regulated)
- Open/Short LED Protection and Fault Flags
- Programmable LED Current Derating
- Adjustable Frequency: 200kHz to 2.1MHz
- Synchronizable to an External Clock
- Analog Dimming Up to 20:1
- Programmable Input UVLO with Hysteresis
- Thermally Enhanced 32-Pin (5mm \times 5mm) QFN and 28-Pin TSSOP Packages

APPLICATIONS

- Automotive Navigation TFT LCD Displays
- Desktop and Notebook TFT LCD Displays

DESCRIPTION

The **LT[®]3599** is a fixed frequency 2A step-up DC/DC converter designed to drive four strings of 120mA LEDs up to a 44V output voltage. The switching frequency is programmable from 200kHz to 2.1MHz through an external resistor.

LED dimming can be achieved with analog dimming on the CTRL pin, and with pulse width modulation dimming on the PWM pin. The LT3599 accurately regulates LED current even when the input voltage is higher than the LED output voltage.

Additional features include programmable LED current derating, switching frequency synchronization to an external clock, LED string disable control, $\overline{\text{OPENLED}}$ alert pin, $\overline{\text{SHORTLED}}$ alert pins and programmable maximum output voltage when all LED strings are disconnected. The LT3599 is available in the thermally enhanced 32-pin (5mm \times 5mm) QFN and 28-pin TSSOP packages.

LT, LT, LTC, LTM, Linear Technology and the Linear logo are registered trademarks of Linear Technology Corporation. True Color PWM is a trademark of Linear Technology Corporation. All other trademarks are the property of their respective owners. Protected by U.S. Patents, including 7199560.

TYPICAL APPLICATION

90% Efficient 12W LED Driver

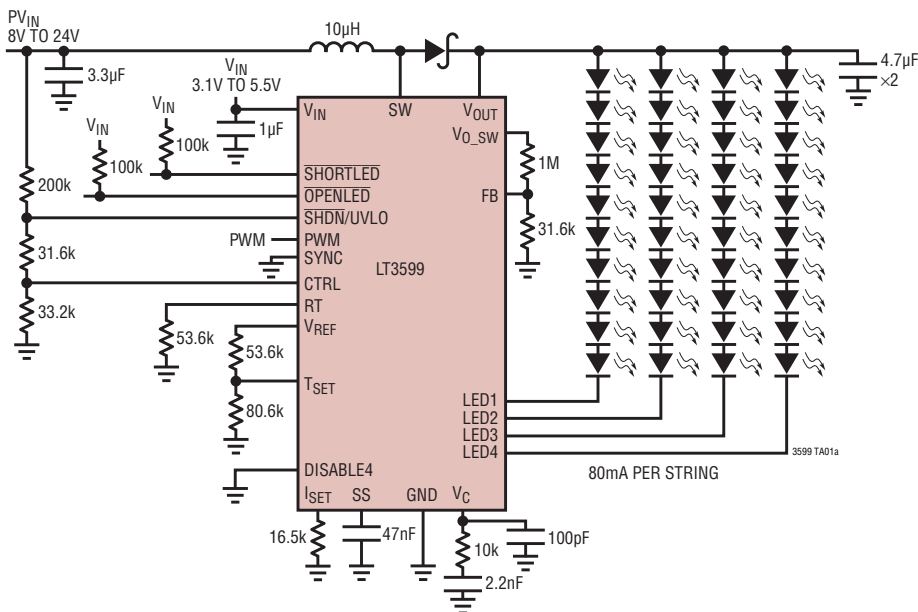

LED Current Matching

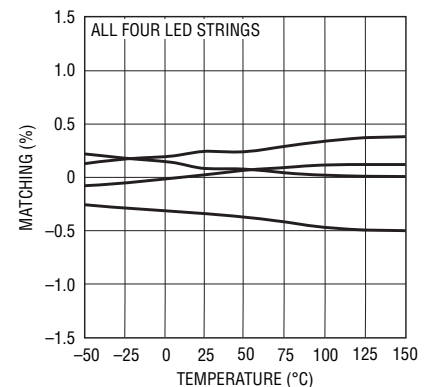

3599ff

LT3599

ABSOLUTE MAXIMUM RATINGS (Note 1)

V_{IN} , $\overline{SHDN}/\overline{UVLO}$, $\overline{OPENLED}$, $\overline{SHORTLED}$	30V
$\overline{SHDN}/\overline{UVLO}$ Pin Above V_{IN}	3V
SW	45V
V_{OUT} , V_{O_SW}	45V
LED1, LED2, LED3, LED4	45V
PWM, SYNC, CTRL, FB, T_{SET} , DISABLE4	6V
V_C , SS	3V
V_{REF} , RT, I_{SET}	2V

Operating Junction Temperature Range (Note 2)	
LT3599E/LT3599I	-40°C to 125°C
LT3599H	-40°C to 150°C
Maximum Junction Temperature	
LT3599E/LT3599I	125°C
LT3599H	150°C
Storage Temperature Range	
	-65°C to 150°C
Lead Temperature (Soldering, sec) (Note 5)	
	300°C

PIN CONFIGURATION

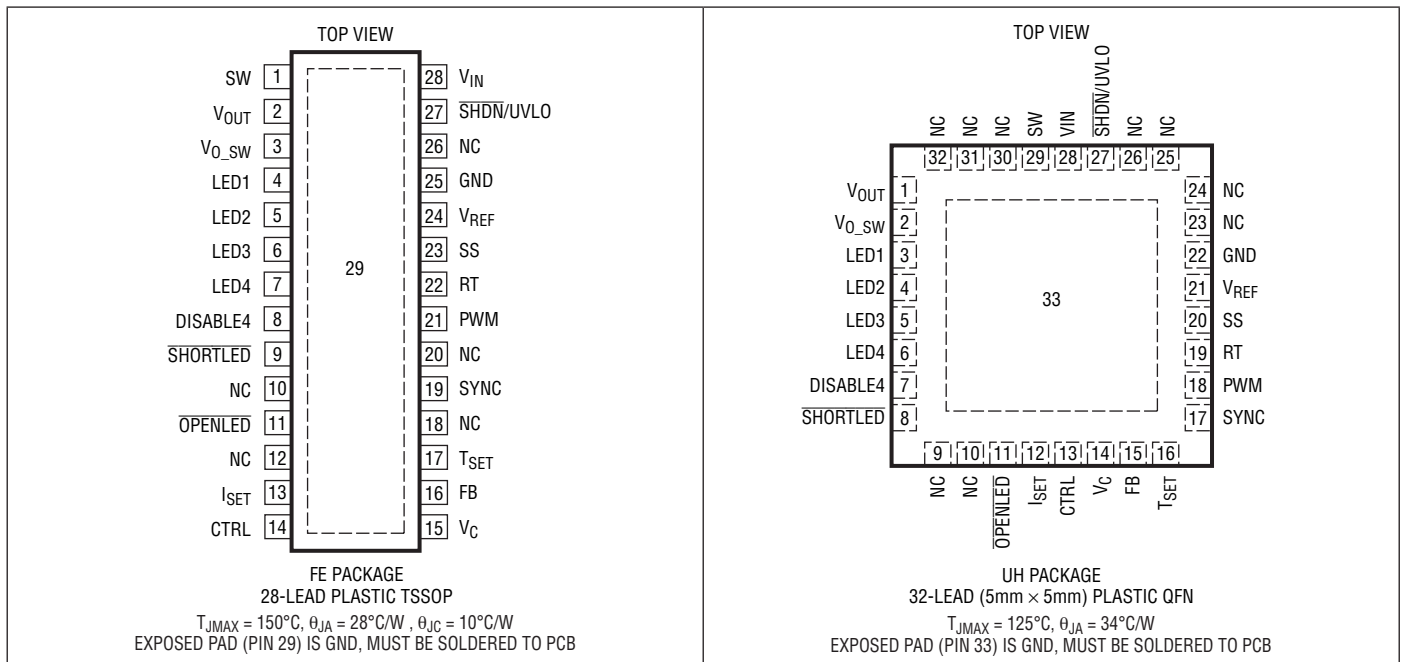

ORDER INFORMATION

LEAD FREE FINISH	TAPE AND REEL	PART MARKING*	PACKAGE DESCRIPTION	TEMPERATURE RANGE
LT3599EFE#PBF	LT3599EFE#TRPBF	LT3599FE	28-Lead Plastic TSSOP	-40°C to 125°C
LT3599IFE#PBF	LT3599IFE#TRPBF	LT3599FE	28-Lead Plastic TSSOP	-40°C to 125°C
LT3599HFE#PBF	LT3599HFE#TRPBF	LT3599FE	28-Lead Plastic TSSOP	-40°C to 150°C
LT3599EUH#PBF	LT3599EUH#TRPBF	3599	32-Lead (5mm x 5mm) Plastic QFN	-40°C to 125°C
LT3599IUH#PBF	LT3599IUH#TRPBF	3599	32-Lead (5mm x 5mm) Plastic QFN	-40°C to 125°C

Consult LTC Marketing for parts specified with wider operating temperature ranges. *The temperature grade is identified by a label on the shipping container. Consult LTC Marketing for information on non-standard lead based finish parts.

For more information on lead free part marking, go to: <http://www.linear.com/leadfree/>

For more information on tape and reel specifications, go to: <http://www.linear.com/tapeandreeel/>. Some packages are available in 500 unit reels through designated sales channels with #TRMPBF suffix.

ELECTRICAL CHARACTERISTICS The ● denotes the specifications which apply over the full operating temperature range, otherwise specifications are at $T_A = 25^\circ\text{C}$. $V_{IN} = 5\text{V}$, $V_{SHDN} = 5\text{V}$, unless otherwise noted. (Note 2)

PARAMETER	CONDITIONS		MIN	TYP	MAX	UNITS
Minimum Operating Voltage		●		2.7	3.1	V
Maximum Operating Voltage		●			30	V
Reference Voltage V_{REF}	$I(V_{REF}) = 0\mu\text{A}$	●	1.21	1.227	1.24	V
			1.20		1.25	V
Reference Voltage Line Regulation	$I(V_{REF}) = 0\mu\text{A}$, $3.1\text{V} < V_{IN} < 30\text{V}$			0.01	0.03	%/V
Maximum V_{REF} Pin Current	(Note 3)				100	μA
V_{REF} Load Regulation	$0 < I(V_{REF}) \leq 100\mu\text{A}$ (Max)			1		mV
Feedback Voltage		●	1.196	1.223	1.250	V
FB Pin Bias Current	(Note 3)			100	250	nA
FB Error Amp Transconductance	$\Delta I = 5\mu\text{A}$			200		μmhos
FB Error Amp Voltage Gain				210		V/V
Current Loop Amp Transconductance				50		μmhos
Current Loop Amp Voltage Gain				50		V/V
V_C Source Current (Out of Pin)	LED1-4 = 0.4V, FB = 1V, $V_C = 1.5\text{V}$			8		μA
V_C Sink Current (OVP Mode)	LED1-4 = 0.4V, FB = 1.5V, $V_C = 1.5\text{V}$			15		μA
Quiescent Current	$V_{SHDN} = 5\text{V}$, PWM = 0V, Not Switching, $V_C = 0.7\text{V}$			3	4.8	mA
Quiescent Current in Shutdown	$V_{SHDN} = 0\text{V}$			0	1	μA
LED Current	$R_{ISET} = 13.3\text{k}$		96	99	102	mA
LED String Current Matching	100mA LED Current	●		± 0.25	± 1.5	%
LED Open Detection Threshold ($V_{LED-GND}$)	FB > 1.25V			0.3	0.4	V
LED Short Detection Threshold ($V_{OUT}-V_{LED}$)			0.8	1.5	2.2	V
LED Regulation Voltage				0.77		V
LED1-4 Leakage Current	$V_{LED1-4} = 45\text{V}$			0.1	1	μA
CTRL Pin Bias Current	$V_{CTRL} = 0.8\text{V}$ (Note 3)			100	200	nA
Switching Frequency	$R_T = 324\text{k}$ $R_T = 53.6\text{k}$ $R_T = 20\text{k}$		176	198	220	kHz
			0.9	1	1.1	MHz
			1.82	2.06	2.3	MHz
T_{SET} Voltage				595		mV
Maximum Switch Duty Cycle	$R_T = 324\text{k}$ $R_T = 53.6\text{k}$ $R_T = 20\text{k}$	● ● ●	97.7 88.5 77	98.6 93 86		%
Switch Current Limit	(Note 4)		2	2.5	3	A
Switch V_{CESAT}	$I_{SW} = 0.5\text{A}$			0.10		V
Switch Leakage Current	$V_{SW} = 45\text{V}$, FB = 1.3V			0.2	5	μA
$\overline{\text{SHDN}}/\text{UVLO}$ Pin Threshold (V_{SD_SHDN})	Shutdown		0.3	0.7	0.95	V
$\overline{\text{SHDN}}/\text{UVLO}$ Pin Threshold (V_{SD_UVLO})	Rising		1.28	1.36	1.44	V
$\overline{\text{SHDN}}/\text{UVLO}$ Pin Hysteresis Current	$\overline{\text{SHDN}} = V_{SD_UVLO} - 50\text{mV}$ $\overline{\text{SHDN}} = V_{SD_UVLO} + 50\text{mV}$		2.5	4	5.5	μA
				0		μA
Soft-Start Current	SS = 1V (Note 3)			11		μA
PWM Input High Threshold					1	V
PWM Input Low Threshold			0.4			V

ELECTRICAL CHARACTERISTICS

The ● denotes the specifications which apply over the full operating temperature range, otherwise specifications are at $T_A = 25^\circ\text{C}$. $V_{IN} = 5\text{V}$, $V_{SHDN} = 5\text{V}$, unless otherwise noted. (Note 2)

PARAMETER	CONDITIONS	MIN	TYP	MAX	UNITS
PWM Pin Bias Current	PWM = 3.3V		0.1	2	μA
SYNC Input High Threshold				2	V
SYNC Input Low Threshold		0.8			V
SYNC Pin Bias Current	SYNC = 0V SYNC = 3.3V		0.1 0.1	1 1	μA μA
V_{O_SW} Switch Resistance				1000	Ω
$\overline{\text{OPENLED}}$ Pull-Down Current	PWM = 5V; LEDx < 0.2V, $\overline{\text{OPENLED}} = 0.3\text{V}$		1		mA
$\overline{\text{SHORTLED}}$ Pull-Down Current	PWM = 5V, $\overline{\text{SHORTLED}} = 0.3\text{V}$		1		mA
DISABLE4 Input High Threshold				1.15	V
DISABLE4 Input Low Threshold		0.4			V

Note 1: Stresses beyond those listed under Absolute Maximum Ratings may cause permanent damage to the device. Exposure to any Absolute Maximum Rating condition for extended periods may affect device reliability and lifetime.

Note 2: The LT3599E is guaranteed to meet performance specifications from 0°C to 125°C junction temperature. Specifications over the -40°C to 125°C operating junction temperature range are assured by design, characterization and correlation with statistical process controls. The LT3599I is guaranteed over the full -40°C to 125°C operating junction

temperature range. The LT3599HFE is guaranteed over the full -40°C to 150°C operating temperature range. High junction temperatures degrade operating lifetimes. Operating lifetime is derated at junction temperatures greater than 125°C .

Note 3: Current flows out of pin.

Note 4: Current limit guaranteed by design and/or correlation to static test. Current limit is independent of duty cycle and is guaranteed by design.

Note 5: TSSOP package only.

TYPICAL PERFORMANCE CHARACTERISTICS $T_A = 25^\circ\text{C}$ unless otherwise specified

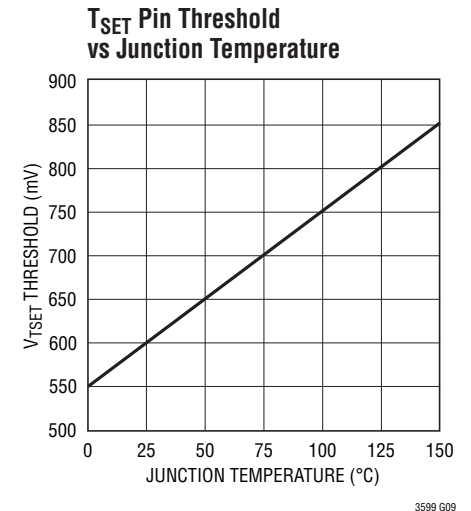
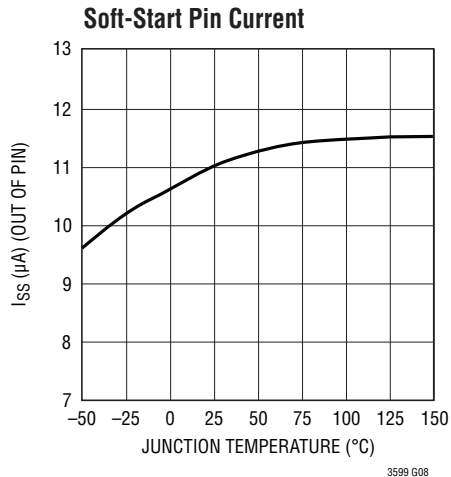
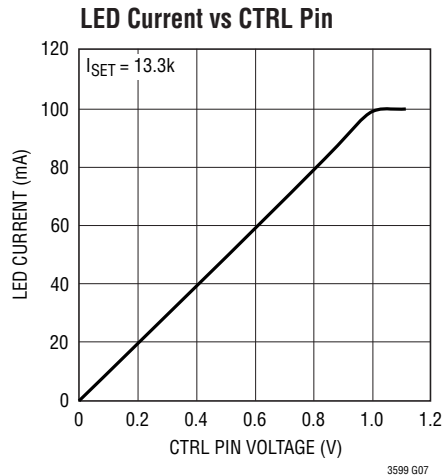
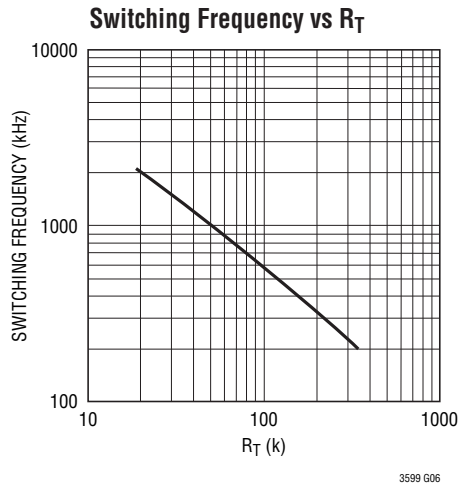
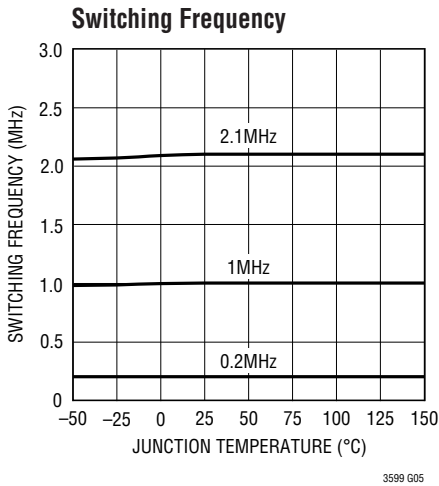
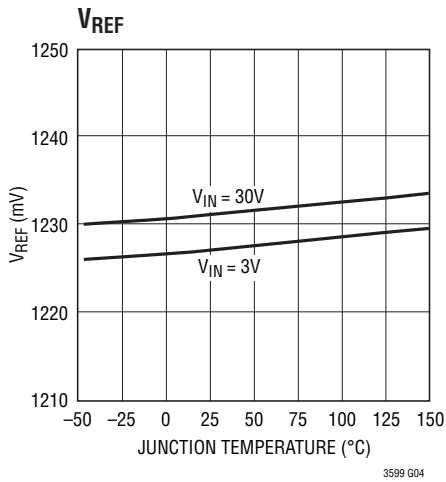
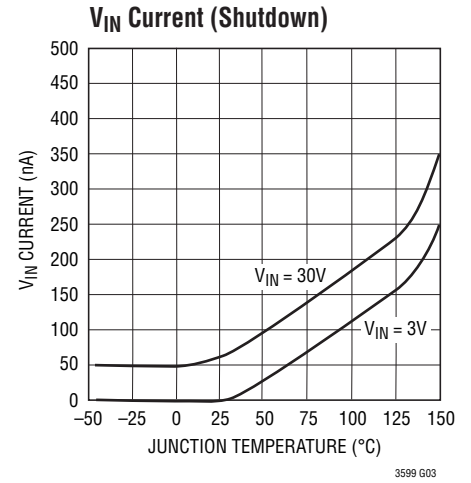
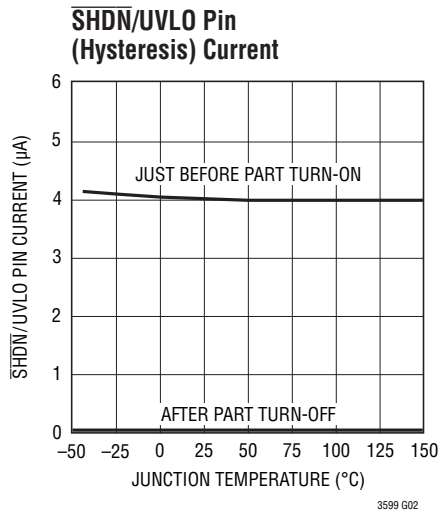
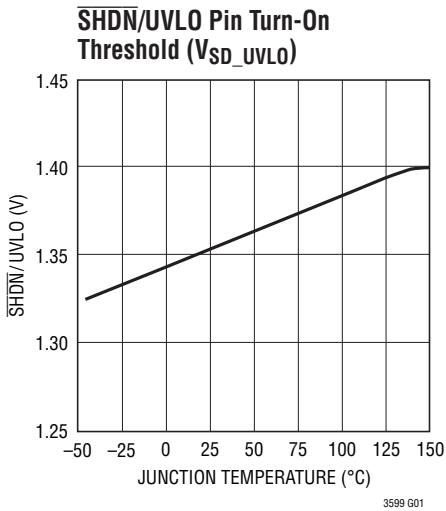

TYPICAL PERFORMANCE CHARACTERISTICS $T_A = 25^\circ\text{C}$ unless otherwise specified

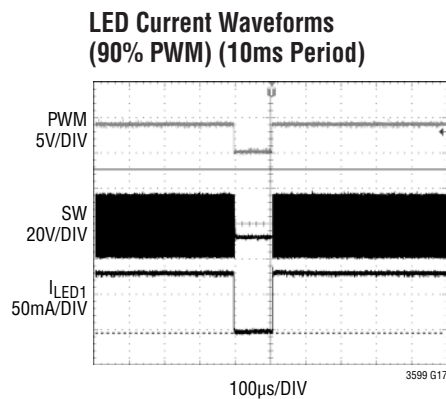
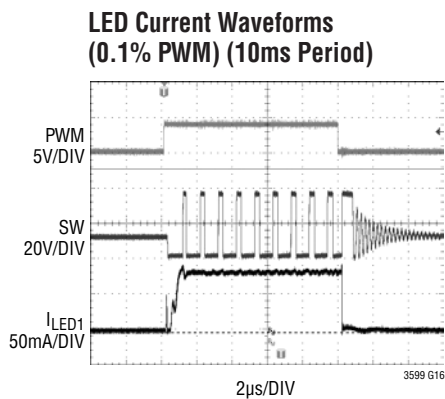
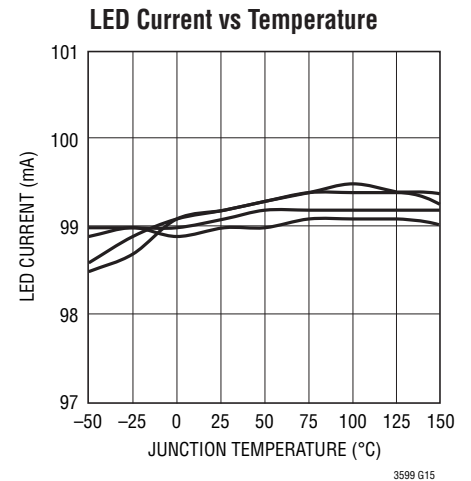
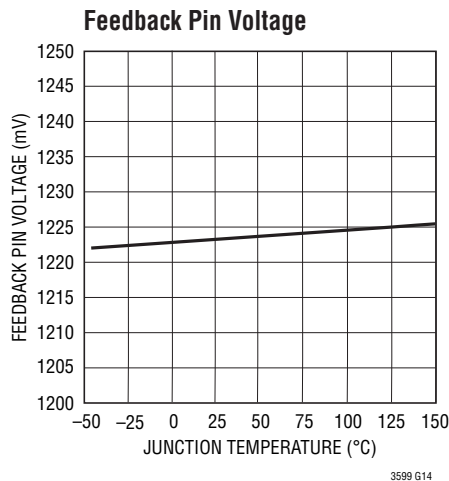
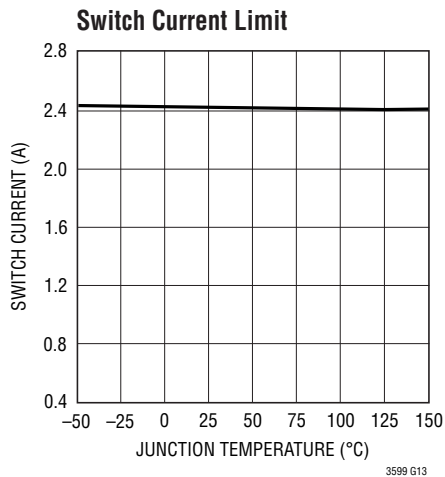
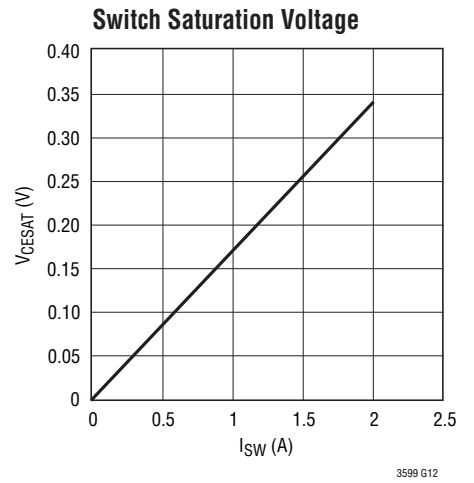
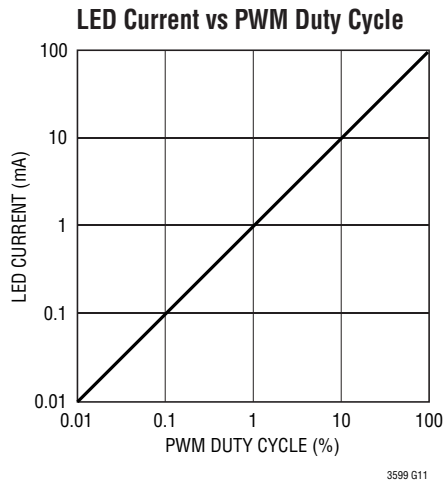
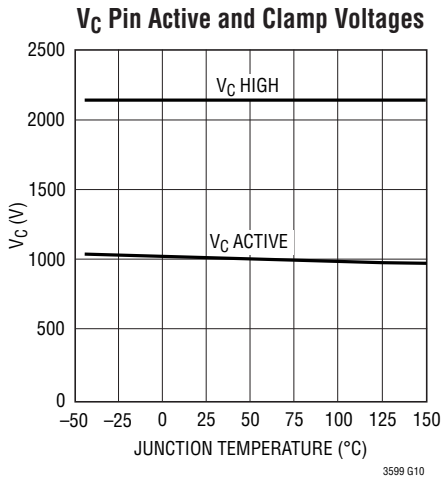

PIN FUNCTIONS

CTRL: LED Current Control. If the CTRL pin is not used, tie this pin to V_{REF} .

DISABLE4: Allows Disabling of LED4. Connect DISABLE4 to V_{REF} to disable LED4. If LED4 is disabled, the LED4 pin should be connected to the LED3 pin. Connect DISABLE4 to ground to allow operation of LED4.

Exposed Pad: Ground. The ground for the IC should be soldered to a continuous copper ground plane under the LT3599 die.

FB: Feedback Pin for Overvoltage Protection. Reference voltage is 1.223V. Connect the resistive divider tap here. Minimize trace area at FB. Set V_{OUT} according to $V_{OUT} = 1.223(1 + R2/R1)$ when overvoltage protection occurs.

GND: Analog Ground. Tie directly to local ground plane. Connect R_T , I_{SET} and T_{SET} resistors between this local ground plane and their respective pins.

I_{SET} : Programs Led Current for Each String. A resistor to ground programs LED currents between 30mA and 120mA.

LED1-4: LED String Output. Connect the bottom cathode of each LED string to these pins.

OPENLED: Open LED Flag. An open-collector output when any LED string opens.

NC: No Connect Pins. Can be left open or connected to any ground plane.

PWM: Input Pin for PWM Dimming Control. Above 1V allows converter switching, and below 0.4V disables switching with V_C pin level maintained. A PWM signal driving the PWM pin provides accurate dimming control. The PWM signal can be driven from 0V to 5V. If unused, the pin should be connected to V_{REF} .

RT: A Resistor to Ground Which Programs Switching Frequency Between 200kHz and 2.1MHz. For SYNC function, choose the resistor to program a frequency 20% slower than the SYNC pulse frequency. Do not leave this pin open.

SHDN/UVLO: The SHDN/UVLO pin has an accurate 1.36V threshold and can be used to program an undervoltage

lockout (UVLO) threshold for system input supply using a resistor divider from supply to ground. A 4 μ A pin current hysteresis allows programming of undervoltage lockout (UVLO) hysteresis. 1.36V turns the part on and removes a 4 μ A sink current from the pin. $\overline{SHDN}/UVLO = 0V$ reduces V_{IN} current < 0.1 μ A. $\overline{SHDN}/UVLO$ can be directly connected to V_{IN} . Do not leave this pin open.

SHORTLED: Indicates a high side short (LED pin shorted to V_{OUT}). This is an open-collector output.

SS: Soft-Start Pin. Place a soft-start capacitor here. Upon start-up, a 11 μ A current charges the capacitor. Use a larger capacitor for a slower start-up.

SW: Switch Pin. This is the collector of the internal NPN power switch. Minimize the metal trace area connected to this pin to minimize EMI.

SYNC: Frequency Synchronization Pin. This input allows for synchronizing the operating frequency to an external clock. The R_T resistor should be chosen to program a switching frequency 20% slower than SYNC pulse frequency. This pin should be grounded if this feature is not used.

T_{SET} : Programs LT3599 junction temperature breakpoint, beyond which LED currents will begin to decrease. An internal V_{PTAT} threshold (see Block Diagram) increases with junction temperature. When V_{PTAT} exceeds T_{SET} pin voltage, LED currents are decreased. If the function is not required, connect T_{SET} pin to V_{REF} pin. If the T_{SET} pin is not used, tie this pin to V_{REF} .

V_C : Error Amplifier Output Pin. Tie the external compensation network to this pin.

V_{IN} : Input Supply Pin. Must be locally bypassed with a capacitor to ground.

V_{O_sw} : Drain of an Internal PMOS. The internal PMOS disconnects the feedback resistors from the V_{OUT} pin during shutdown and when the PWM pin is low.

V_{OUT} : Output Pin. This pin provides power to all LEDs.

V_{REF} : Bandgap Voltage Reference. Internally set to 1.227V. This pin can supply up to 100 μ A. Can be used to program the CTRL pin voltage using resistor dividers to ground.

BLOCK DIAGRAM

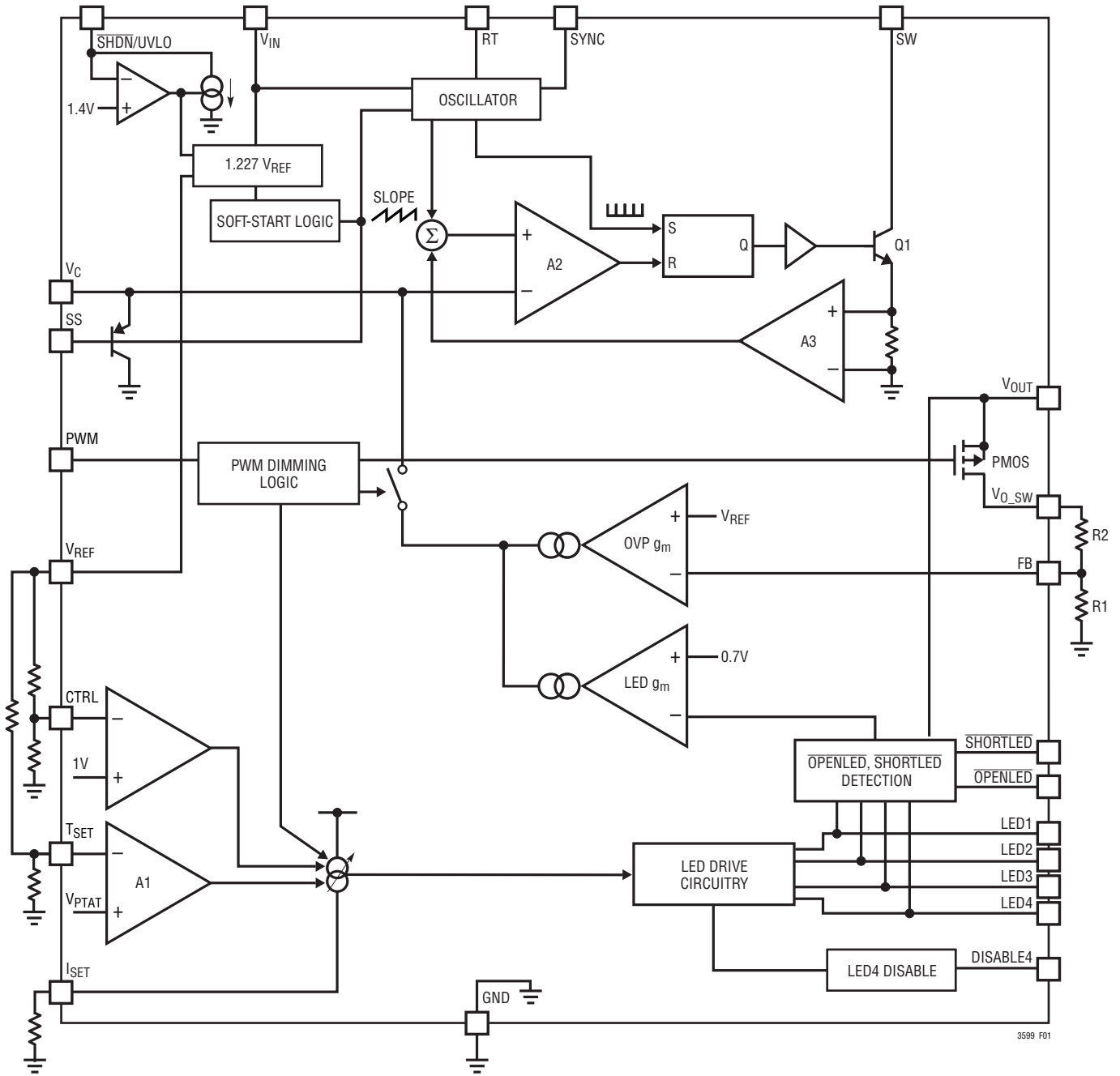

Figure 1. Block Diagram

OPERATION

The LT3599 uses a constant-frequency, peak current mode control scheme to provide excellent line and load regulation. Operation can be best understood by referring to the Block Diagram in Figure 1.

To turn on the LT3599, the V_{IN} pin must exceed 3.1V and the $\overline{SHDN}/UVLO$ pin must exceed 1.4V. The $\overline{SHDN}/UVLO$ pin threshold allows programming of an undervoltage lockout (UVLO) threshold for the system input supply using a simple resistor divider. A $4\mu A$ current flows into the $\overline{SHDN}/UVLO$ pin before the part turns on and is removed after the part turns on. This current hysteresis allows the programming of hysteresis for the UVLO threshold. See “Shutdown Pin and Programming Undervoltage Lockout” in the Applications Information section. For part switching, the PWM pin must exceed 1V (typical). For micropower shutdown, the $\overline{SHDN}/UVLO$ pin at 0V reduces V_{IN} supply current to approximately $\sim 0\mu A$.

LT3599 has a built-in boost converter which converts the input voltage to a higher output voltage for driving LEDs. The LED strings are connected to current sources where the current level is set with an external resistor on the I_{SET} pin. The LED1 to LED4 voltages are monitored for output voltage regulation. During normal operation, when all LEDs are used, the lowest LED pin voltage (LED1 to LED4) is used to regulate the output voltage to ensure all LED strings have enough voltage to run the programmed current.

If the user prefers only three strings, then LED string 4 can be disabled through the DISABLE4 pin and by connecting LED4 to any other LED pin. If the user prefers only two strings, then two pins are connected in parallel (i.e., LED1, 2 and LED3, 4 can be connected together in operation).

The basic loop uses a pulse from an internal oscillator to set the SR latch and turn on the internal power NPN switch Q1. The signal at the noninverting input of the PWM comparator (A2) is proportional to the sum of the switch current and oscillator ramp. When this signal exceeds the V_C voltage, the PWM comparator resets the latch. The switch is then turned off, causing the inductor current to lift the SW pin and turn on an external Schottky diode connected to the output. Inductor current flows via the Schottky diode charging the output capacitor. The switch is turned on again at the next reset cycle of the internal oscillator. During normal operation, the V_C voltage controls

the peak switch current limit and, hence, the inductor current available to the output LEDs.

Dimming of the LEDs is accomplished by either PWM dimming or analog dimming. PWM dimming is achieved by pulsing the LED current using the PWM pin. For constant color LED dimming, the LT3599 provides up to a 3000:1 wide PWM dimming range by allowing the duty cycle of the PWM pin to be reduced from 100% to as low as 0.033%. When the PWM pin is low, switching is disabled and the error amplifier is turned off so that it does not drive the V_C pin. Also, all internal loads on the V_C pin are disabled so that the state of the V_C pin is maintained on the external compensation capacitor. This feature reduces transient recovery time. When the PWM input again transitions high, the peak switch current returns to the correct value. In applications where the user can sacrifice $\overline{OPENLED}$, $\overline{SHORTLED}$ fault flag diagnostics, the dimming ratios can be as high as 3000:1. Analog dimming of LED currents is accomplished by varying the level of CTRL pin voltage. This method, however, changes LED color since dimming is achieved by changing LED current. For CTRL pin voltage less than 1V, LED current is defined as:

$$I_{LED} = V_{CTRL} \cdot \left(\frac{1330}{R_{ISET}} \right) \text{ (Amps)}$$

The LT3599 uses the FB pin to provide overvoltage protection when all LED strings are open. There is an internal PMOS switch between V_{OUT} and V_{O_SW} that is controlled by the PWM signal. During the PWM off-period, this PMOS is turned off, allowing for higher dimming range and lower current during shutdown. A resistor divider is connected between the V_{O_SW} pin and ground, which sets the overvoltage protection voltage.

If the LED1-4 pin voltage is below 0.3V, the string is treated as an open LED string. As a result, an $\overline{OPENLED}$ flag is set. If a LED string is opened during regular operation, the output voltage will regulate to the optimum voltage for the remaining connected strings.

If a short occurs between V_{OUT} and any LED pin during operation, the LT3599 immediately turns off the LED pin current of the shorted string and sets a $\overline{SHORTLED}$ flag. Disabling the LED pin current protects the LT3599 from high power thermal dissipation and ensures reliable operation.

3599ff

OPERATION

SHORTLED and OPENLED detection are disabled during the start-up phase to avoid false flag generation. If an LED string is open during normal operation, it will no longer be used to regulate the output voltage. The output voltage will regulate itself to find the LED string with the lowest LED pin voltage. Fault detection (SHORTLED, OPENLED) is updated when the PWM pin is high and latched when the PWM pin is low.

During start-up, 11 μ A of current charges the external soft-start capacitor. The SS pin directly limits the rate of voltage rise on the V_C pin, which in turn, limits the peak switch current. Soft-start also enables switching frequency foldback to provide a clean start-up for the LT3599. Switch current limit protects the power switch and external components.

APPLICATIONS INFORMATION

Inductor Selection

Table 1 lists several inductors that work well with the LT3599, however, there are many other manufacturers and devices that can be used. Consult each manufacturer for detailed information on their entire range of parts. Ferrite core inductors should be used to obtain the best efficiency. Choose an inductor that can handle the necessary peak current without saturating. Also, ensure that the inductor has a low DCR (copper wire resistance) to minimize I²R power losses. Values between 4.7 μ H and 22 μ H will suffice for most applications.

Inductor manufacturers specify the maximum current rating as the current where inductance falls by a given percentage of its nominal value. An inductor can pass a current greater than its rated value without damaging it. Consult each manufacturer to determine how the maximum inductor current is measured and how much more current the inductor can reliably conduct.

Table 1. Recommended Inductors

PART	L (μ H)	MAX DCR (Ω)	CURRENT RATING (A)	VENDOR
B1015AS-100M	10	0.07	2.2	TOKO
817FY-4R7M	4.7	0.06	2.26	www.toko.com
744065100	10	0.04	3	Würth Electronics
74454068	6.8	0.055	2.2	www.we-online.com
74454010	10	0.065	2	
CDH115-100	10	0.028	3	Sumida
CDH74NP-120L	12	0.065	2.45	www.sumida.com
CDH74NP-150L	15	0.083	2.10	
IHLP2020-BZ	10	0.184	2.3	Vishay
IHLP2525-BD	10	0.116	2.5	www.vishay.com

Capacitor Selection

Low ESR (equivalent series resistance) ceramic capacitors should be used at the output to minimize the output ripple voltage. Use only X5R or X7R dielectrics, as these materials retain their capacitance over wider voltage and temperature ranges than other dielectrics. A 4.7 μ F to 10 μ F output capacitor is sufficient for most high output current designs. Table 2 lists some suggested manufacturers. Consult the manufacturers for detailed information on their entire selection of ceramic parts.

Table 2. Recommended Ceramic Capacitor Manufacturers

Taiyo Yuden	(408) 573-4150 www.t-yuden.com
AVX	(843) 448-9411 www.avxcorp.com
Murata	(770) 436-1300 www.murata.com
Kemet	(408) 986-0424 www.kemet.com

Diode Selection

Schottky diodes, with their low forward voltage drop and fast switching speed, should be used for all LT3599 applications. Table 3 lists several Schottky diodes that work well. The diode's average current rating must exceed the application's average output current. The diode's maximum reverse voltage must exceed the application's output voltage. A 2A diode is sufficient for most designs. For PWM dimming applications, be aware of the reverse leakage current of the diode. Lower leakage current will drain the output capacitor less, allowing for higher dimming range.

APPLICATIONS INFORMATION

The companies below offer Schottky diodes with high voltage and current ratings. Standard silicon diodes (PN junction diodes) should not be used.

Table 3. Suggested Diodes

PART	MAX CURRENT (A)	MAX REVERSE VOLTAGE (V)	MANUFACTURER
B250A	2	50	Diodes, Inc. www.diodes.com
DFLS240	2	40	
B240A	2	40	
B350A	3	50	
B340A	3	40	
HSM150G	1	50	Microsemi www.microsemi.com
HSM150J	1	50	
HSM350G	3	50	

Overvoltage Protection

The LT3599 uses the FB pin to provide overvoltage protection. A resistor divider is connected between the V_{O_SW} pin and ground (Figure 2). There is an internal PMOS switch between V_{OUT} and V_{O_SW} , which is controlled by the PWM signal. The PMOS switch addition prevents the feedback resistor divider from draining the output capacitor during PWM off-period, allowing for a higher dimming range without falsely tripping the $\overline{OPENLED}$ flag. It also reduces the system current in shutdown. This PMOS has about 1k resistance, so select FB resistor values taking this resistance into account.

To set the maximum output voltage, select the values of R1 and R2 (see Figure 2) according to the following equation:

$$V_{OUT(MAX)} = 1.223V \left(1 + \frac{R2}{R1} \right)$$

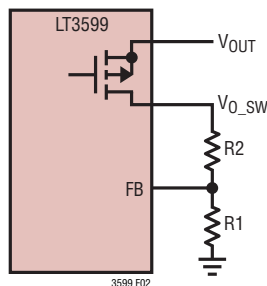

Figure 2. Overvoltage Protection Voltage Feedback Connections

The output voltage should be set 10% higher than the normal LED string operating voltage. Under normal operation, LED1 to LED4 pin voltages are monitored and provide feedback information to the converter for output voltage regulation given the programmed LED current. The output voltage regulation loop is activated only when all LEDs are open.

Programming Maximum LED Current

Maximum LED current can be programmed by placing a resistor between the I_{SET} pin and ground (R_{ISET}). The I_{SET} pin resistor can be selected from 11k to 44.2k.

The LED current can be programmed according to the following equation:

$$I_{LED} \approx \frac{1330}{R_{ISET}} \text{ (Amps) (CTRL > 1V)}$$

See Table 4 and Figure 3 for resistor values and corresponding programmed LED current.

LED current can also be adjusted by programming the CTRL pin voltage.

Table 4. R_{ISET} Value Selection for LED Current

LED CURRENT (mA)	RESISTOR ON I_{SET} PIN (k)
30mA	44.2
50mA	26.7
99mA	13.3
120mA	11

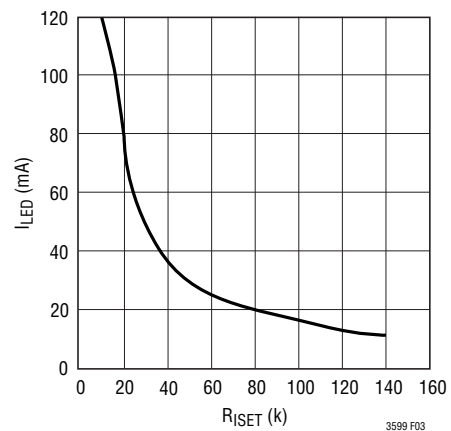

Figure 3. R_{ISET} Value Selection for LED Current

APPLICATIONS INFORMATION

LED Current Dimming

Two different types of dimming control can be used with the LT3599. The LED brightness can be set either by analog dimming (CTRL pin voltage adjustment between 0V and 1V) or PWM dimming (PWM pin duty cycle adjustment).

For some applications, the preferred method of brightness control is to use a variable DC input voltage. The CTRL pin voltage can be adjusted to set the dimming of the LED string (see Figures 4 and 5). As the voltage on the CTRL pin increases from 0V to 1V, the LED current increases from 0 to the programmed LED current level. Once the CTRL pin voltage increases beyond 1V, it has no effect on the LED current.

For True Color PWM dimming, the LT3599 provides up to a 3000:1 PWM dimming range by allowing the duty cycle of the PWM pin to be reduced from 100% to as low

as 0.033% at a PWM frequency of 100Hz (Figure 6). Dimming by PWM duty cycle, allows for constant LED color to be maintained over the entire dimming range.

For LT3599 PWM dimming control during startup and normal operation, observe the following guidelines:

(1) STARTUP

LT3599 V_{OUT} start-up requires the $\overline{SHDN}/UVLO$ and PWM pins to be asserted from off to on and the PWM on-time to be above a minimum value. The lowest PWM on-time allowed for fault detection is $\approx 4\mu s$. The lowest PWM on-time allowed for reaching V_{OUT} regulation is typically $4\mu s$ but might be greater depending on external circuit parameters. Once LED current is in regulation, PWM on-time can be reduced as low as $3\mu s$ depending on external component selection.

(2) V_{OUT} Collapse

If during normal operation V_{OUT} collapses due to a fault or because PWM on-time is too low, a re-start is required (see STARTUP in item (1)).

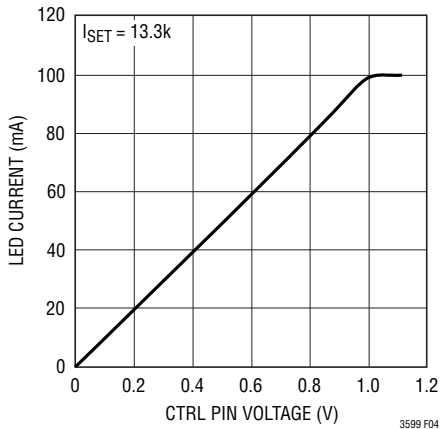

Figure 4. LED Current vs CTRL Voltage

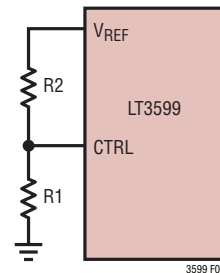

Figure 5. LED Current vs CTRL

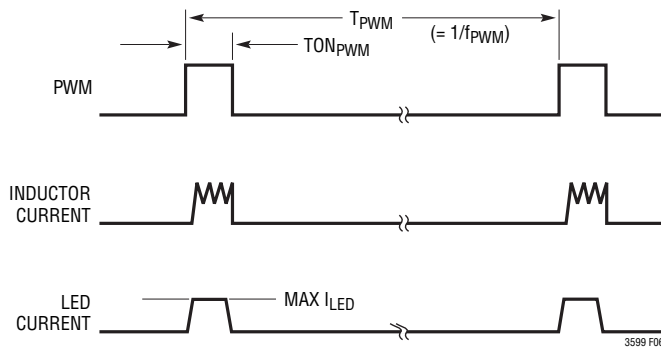

Figure 6. LED Current Using PWM Dimming

APPLICATIONS INFORMATION

PROGRAMMING LED CURRENT DERATING vs TEMPERATURE

Programming LED Current Derating Using the CTRL Pin

A useful feature of the LT3599 is its ability to program a derating curve for maximum LED current versus temperature. LED data sheets provide curves of maximum-allowable LED current versus temperature to warn against exceeding this current limit and damaging the LED. The LT3599 allows the output LEDs to be programmed for maximum allowable current while still protecting the LEDs from excessive currents at high temperature. This is achieved by programming a voltage at the CTRL pin with a negative temperature coefficient using a resistor divider with temperature dependent resistance (Figure 7). As the temperature increases, the CTRL voltage will fall below the internal 1V voltage reference, causing LED currents to be controlled by the CTRL pin voltage. The LED current curve breakpoint and slope versus temperature is defined by the choice of resistor ratios and use of temperature-dependent resistance in the divider for the CTRL pin.

A variety of resistor networks and NTC resistors with different temperature coefficients can be used for programming CTRL to achieve the desired CTRL curve vs temperature.

Table 5 shows a list of manufacturers/distributors of NTC resistors. There are several other manufacturers available and the chosen supplier should be contacted for more detailed information. If an NTC resistor is used to indicate LED temperature, it is effective only if the resistor is connected as closely as possible to the LED strings. LED derating curves shown by manufacturers are listed for ambient temperature. The NTC resistor should have the same ambient temperature as the LEDs. Since the temperature dependency of an NTC resistor can be non-

linear over a wide range of temperatures, it is important to obtain a resistor's exact values over temperature from the manufacturer. Hand calculations of CTRL voltage can then be performed at each given temperature, resulting in the CTRL versus temperature plotted curve. Several iterations of resistor value calculations may be required to achieve the desired breakpoint and slope of the LED current derating curve.

Table 5. NTC Resistor Manufacturers/Distributors

Murata Electronics North America	(770) 436-1300 www.murata.com
TDK Corporation	(516) 535-2600 www.tdk.com
Digi-Key	(800) 344-4539 www.digikey.com

If calculating the CTRL voltage at various temperatures gives a downward slope that is too strong, alternative resistor networks can be chosen (B, C, D in Figure 7) which use temperature-independent resistance to reduce the effects of the NTC resistor overtemperature.

Murata Electronics provides a selection of NTC resistors with complete data over a wide range of temperatures. In addition, a software tool is available which allows the user to select from different resistor networks and NTC resistor values, and then simulate the exact output voltage curve (CTRL behavior) over temperature. Referred to as the "Murata Chip NTC Thermistor Output Voltage Simulator," users can log onto www.murata.com/designlib and download the software followed by instructions for creating an output voltage V_{OUT} (CTRL) from a specified V_{CC} supply (V_{REF}). At any time during the selection of circuit parameters, the user can access data on the chosen NTC resistor by clicking on a link to the Murata catalog.

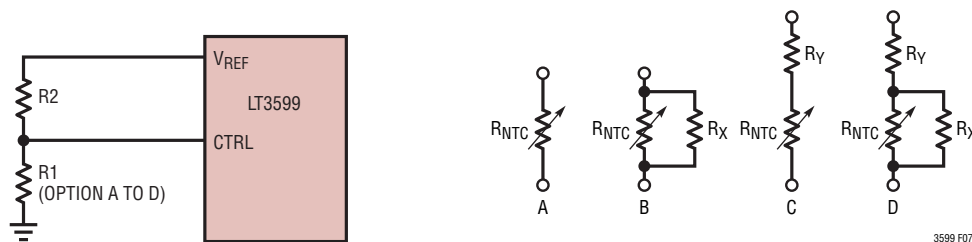

Figure 7 . LED Current Derating vs Temperature Using NTC Resistor

APPLICATIONS INFORMATION

Using the T_{SET} Pin for Thermal Protection

The LT3599 contains a special programmable thermal regulation loop that limits the internal junction temperature of the part. Since the LT3599 topology consists of a single boost converter with four linear current sources, any LED string voltage mismatch will cause additional power to be dissipated in the package. This topology provides excellent current matching between LED strings and allows a single power stage to drive a large number of LEDs, but at the price of additional power dissipation inside the part (which means a higher junction temperature). Being able to limit the maximum junction temperature allows the benefits of this topology to be fully realized. This thermal regulation feature provides important protection at high ambient temperatures, and allows a given application to be optimized for typical, not worst case, ambient temperatures with the assurance that the LT3599 will automatically protect itself and the LED strings under worst-case conditions.

The operation of the thermal loop is simple. As the ambient temperature increases, so does the internal junction temperature of the part. Once the programmed maximum junction temperature is reached, the LT3599 begins to linearly reduce the LED current, as needed, to try and maintain this temperature. This can only be achieved when the ambient temperature stays below the desired maximum junction temperature. If the ambient temperature continues to rise past the programmed maximum junction temperature, the LEDs' current will be reduced to approximately 5% of the full LED current.

While this feature is intended to directly protect the LT3599, it can also be used to derate the LED current at high temperatures. Since there is a direct relationship between the LED temperature and LT3599 junction temperature, the T_{SET} function also provides some LED current derating at high temperatures.

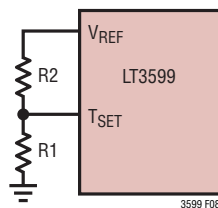

Figure 8. Programming the T_{SET} Pin

Two external resistors program the maximum IC junction temperature using a resistor divider from the V_{REF} pin, as shown in Figure 8. Choose the ratio of R1 and R2 for the desired junction temperature. Table 6 shows commonly used values for R1 and R2 (see T_{SET} graph).

Table 6. Resistor Values to Program Maximum IC Junction Temperature

T _J (°C)	R1 (k)	R2 (k)
100	80.6	53.6
105	82.5	53.6
110	82.5	51.1
115	84.5	51.1
120	84.5	49.9
135	84.5	44.2
145	90.9	44.2

Programming Switching Frequency

The switching frequency of the LT3599 is set between 200kHz and 2.1MHz by an external resistor connected between the RT pin and ground (see Table 7). Do not leave this pin open.

Selecting the optimum switching frequency depends on several factors. Inductor size is reduced with higher frequency, but efficiency drops due to higher switching losses. In addition, some applications require very high duty cycles to drive a large number of LEDs from a low supply. Low switching frequency allows a greater operational duty cycle and, hence, a greater number of LEDs to be driven. In each case, the switching frequency can be tailored to provide the optimum solution. When programming the switching frequency, the total power losses within the IC should be considered.

Table 7. Switching Frequency

SWITCHING FREQUENCY (MHz)	R _T (k)
2.1	20
2.0	21.5
1.5	31.6
1.0	53.6
0.5	121
0.4	154
0.3	210
0.2	324

3599ff

APPLICATIONS INFORMATION

Switching Frequency Synchronization

The nominal operating frequency of the LT3599 is programmed using a resistor from the RT pin to ground and can be controlled over a 200kHz to 2.1MHz range. In addition, the internal oscillator can be synchronized to an external clock applied to the SYNC pin. The synchronizing clock signal input to the LT3599 must have a frequency between 240kHz and 2MHz, a pulse on-time of at least 50ns, a pulse off-time of at least 300ns, a low state below 0.8V and a high state above 2V. Synchronization signals outside of these parameters will cause erratic switching behavior. For proper operation, an R_T resistor should be chosen to program a switching frequency 20% slower than the SYNC pulse frequency. Synchronization occurs at a fixed delay after the rising edge of SYNC.

The SYNC pin should be grounded if the clock synchronization feature is not used. When the SYNC pin is grounded, the internal oscillator generates switching frequency to the converter.

Shutdown and Programming Undervoltage Lockout

The LT3599 has an accurate 1.4V shutdown threshold at the $\overline{\text{SHDN}}/\text{UVLO}$ pin. This threshold can be used in conjunction with a resistor divider from the system input supply to define an accurate undervoltage lockout (UVLO) threshold for the system (Figure 10). A pin current hysteresis allows programming of the hysteresis voltage for this UVLO threshold. Just before the part turns on, $4\mu\text{A}$

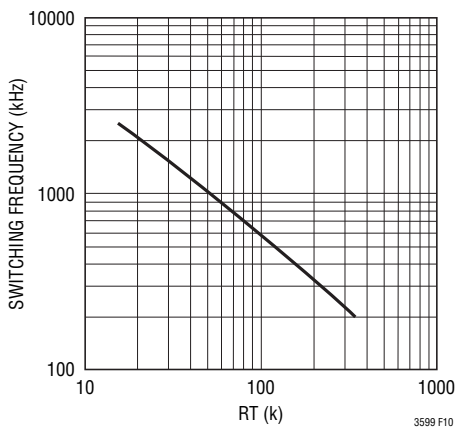

Figure 9. Switching Frequency

flows into the $\overline{\text{SHDN}}/\text{UVLO}$ pin. After the part turns on, $0\mu\text{A}$ flows from the $\overline{\text{SHDN}}/\text{UVLO}$ pin. Calculation of the on/off thresholds for a system input supply using the LT3599 $\overline{\text{SHDN}}/\text{UVLO}$ pin can be made as follows :

$$V_{S(\text{OFF})} = 1.4 \left(1 + \frac{R1}{R2} \right)$$

$$V_{S(\text{ON})} = V_{S(\text{OFF})} + (4\mu\text{A} \cdot R1)$$

A simple open drain transistor can be added to the resistor divider network at the $\overline{\text{SHDN}}/\text{UVLO}$ pin to independently control the turn off of the LT3599.

With the $\overline{\text{SHDN}}/\text{UVLO}$ pin connected directly to the V_{IN} pin, an internal undervoltage lockout threshold of approximately 2.7V exists for the V_{IN} pin. This prevents the converter from operating in an erratic mode when supply voltage is too low. The LT3599 provides a soft-start function when recovering from such faults as $\overline{\text{SHDN}} < 1.4\text{V}$ and/or $V_{\text{IN}} < 2.7\text{V}$. See “Soft-Start” in the Applications Information section for details.

Soft-Start and Switching Frequency Foldback

To limit inrush current and output voltage overshoot during start-up/recovery from a fault condition, the LT3599 provides a soft-start pin, SS. The SS pin is used to program switch current ramp-up timing using a capacitor to ground. The LT3599 monitors system parameters for the following faults: $V_{\text{IN}} < 2.7\text{V}$ or $\overline{\text{SHDN}} < 1.4$. On detection of any of these faults, the LT3599 stops switching im-

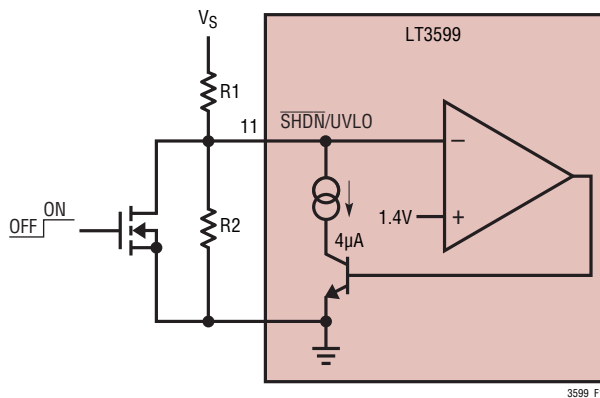

Figure 10. Programming Undervoltage Lockout (UVLO) with Hysteresis

APPLICATIONS INFORMATION

mediately and a soft-start latch is set causing the SS pin to be discharged (see the Soft-Start Pin Timing Diagram in Figure 11). All faults are detected internally and do not require external components. When all faults no longer exist and the SS pin has been discharged to at least 0.25V, the soft-start latch is reset and an internal 11µA supply charges the SS pin. During start-up or recovery from a fault, the SS pin ramp up controls the ramp up of switch current limit. Soft-start ramp rate is given by:

$$\frac{\Delta V_{SS}}{\Delta T} = \frac{I_{SS}}{C_{SS}} \quad (I_{SS} = 11\mu\text{A typ})$$

A 10nF capacitor from the SS pin to ground will therefore provide a 1V/ms ramp rate on the SS pin.

In addition, during soft-start, switching frequency is reduced to protect the inductor from high currents.

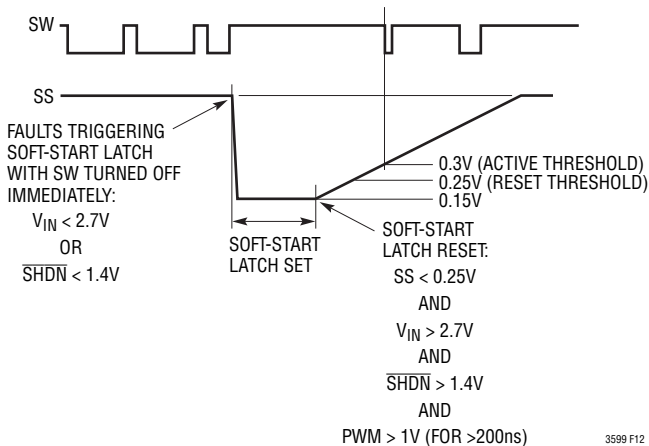

Figure 11. Soft-Start Pin Timing Diagram

A useful feature of the LT3599 is that it waits for the first PWM pin active high (minimum 200ns pulse width) before it allows the soft-start of V_C pin to begin. This feature ensures that during start-up of the LT3599 the soft-start ramp has not timed out before PWM is asserted high. Without this ‘wait for PWM high’ feature, systems which apply PWM after V_{IN} and $\overline{\text{SHDN}}$ are valid, can potentially turn on without soft-start and experience high inductor currents during wake up of the converter’s output voltage. It is important to note that when PWM subsequently goes low, the soft-start ramp is not held at its present voltage but continues to ramp upwards. If the soft-start ramp voltage was held every time PWM goes low, this would

cause very slow start-up of LED displays for applications using very high PWM dimming ratios.

OPENLED FLAG

The $\overline{\text{OPENLED}}$ pin is an open-collector output and needs an external resistor tied to a supply (see Figure 12). If any LED string is open during normal operation, the $\overline{\text{OPENLED}}$ pin will be pulled down.

The open LED detection is enabled only when the PWM signal is enabled. There is a delay for $\overline{\text{OPENLED}}$ flag generation when the PWM signal is enabled to avoid generating a spurious flag signal.

During start-up (see the Operation section), the open LED detection is disabled.

SHORTLED FLAG

The $\overline{\text{SHORTLED}}$ pin is an open-collector output, and needs an external resistor tied to a supply (see Figure 12). If any LED pin is shorted to V_{OUT} during normal operation, the $\overline{\text{SHORTLED}}$ pin will be pulled down. In addition, the shorted LED string is immediately disabled, thereby protecting the LT3599. During the short circuit fault, cable inductance can cause the LED pin voltage to overshoot past V_{OUT} voltage. To avoid LED pin voltage exceeding it’s absolute maximum rated voltage, the anode of a 1N4148WS diode should be connected to the LED pin and the cathode of the diode connected to the V_{OUT} pin. Keep the traces as short as possible. A Schottky diode should not be used due to high reverse bias leakage currents.

The short LED detection is enabled only when the PWM signal is enabled. There is a delay for $\overline{\text{SHORTLED}}$ flag generation when the PWM signal is enabled to avoid spurious signal being generated.

During start-up, the $\overline{\text{SHORTLED}}$ flag is disabled (see the Operation section).

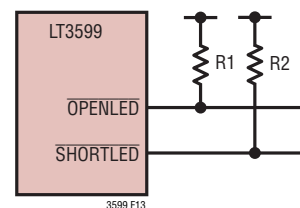

Figure 12. $\overline{\text{OPENLED}}$ and $\overline{\text{SHORTLED}}$ Connection

APPLICATIONS INFORMATION

Loop Compensation

The LT3599 has an internal transconductance error amplifier for LED current regulation whose V_C output compensates the control loop. During overvoltage, the V_C node also compensates the control loop. The external inductor, output capacitor, and the compensation resistor and capacitor determine the loop stability. The inductor and output capacitor are chosen based on performance, size and cost. The compensation resistor and capacitor at V_C are selected to optimize control loop stability. For typical LED applications, a 2.2nF compensation capacitor in series with a 10k resistor at V_C is adequate.

Thermal Consideration

The LT3599 provides current for four LED strings with internal NPN devices serving as constant-current sources. When LED strings are regulated, the lowest LED pin voltage is 0.7V. The higher the programmed LED current, the more power dissipation in the LT3599. For 100mA LED

programming current with a 100% PWM dimming ratio, at least 280mW is dissipated within the IC due to current sources. Thermal calculations shall include the power dissipation on current sources in addition to conventional switch DC loss, switch AC loss and input quiescent loss. For best efficiency, it is recommended that all strings have the same number of LEDs, and each string has a similar voltage drop across the LEDs.

Board Layout Considerations

As with all switching regulators, careful attention must be paid to the PCB board layout and component placement. To prevent electromagnetic interference (EMI) problems, proper layout of high frequency switching paths is essential. Minimize the length and area of all traces connected to the switching node pin (SW). Always use a ground plane under the switching regulator to minimize interplane coupling. Good grounding is essential in LED fault detection. Recommended component placement is shown in Figure 13.

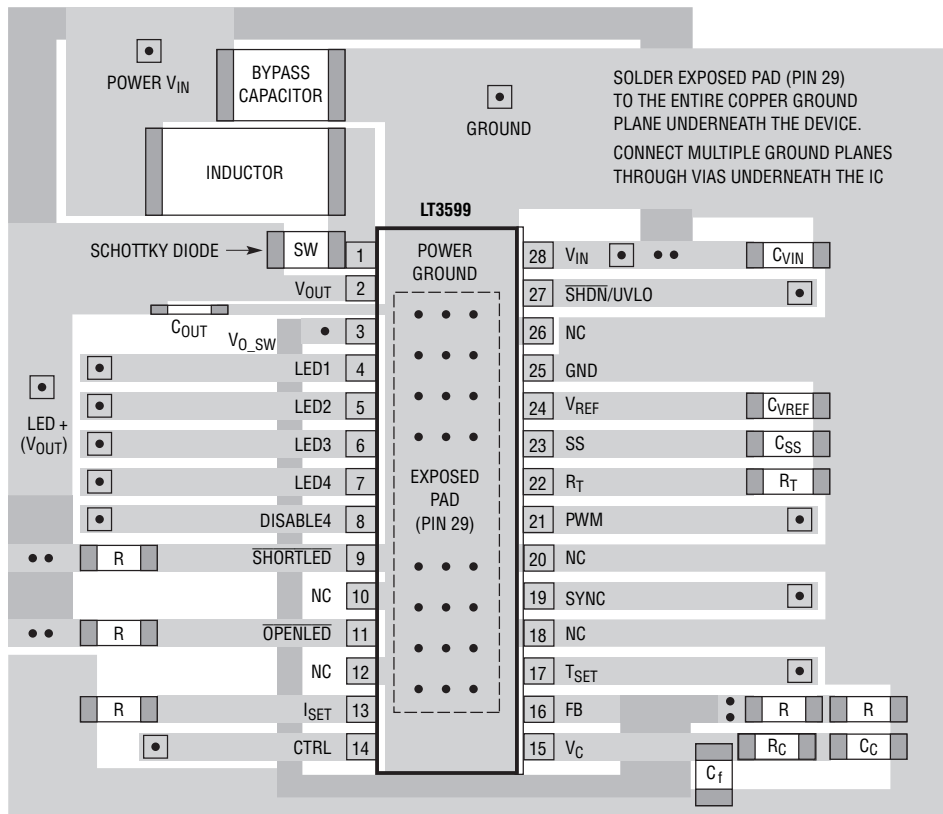
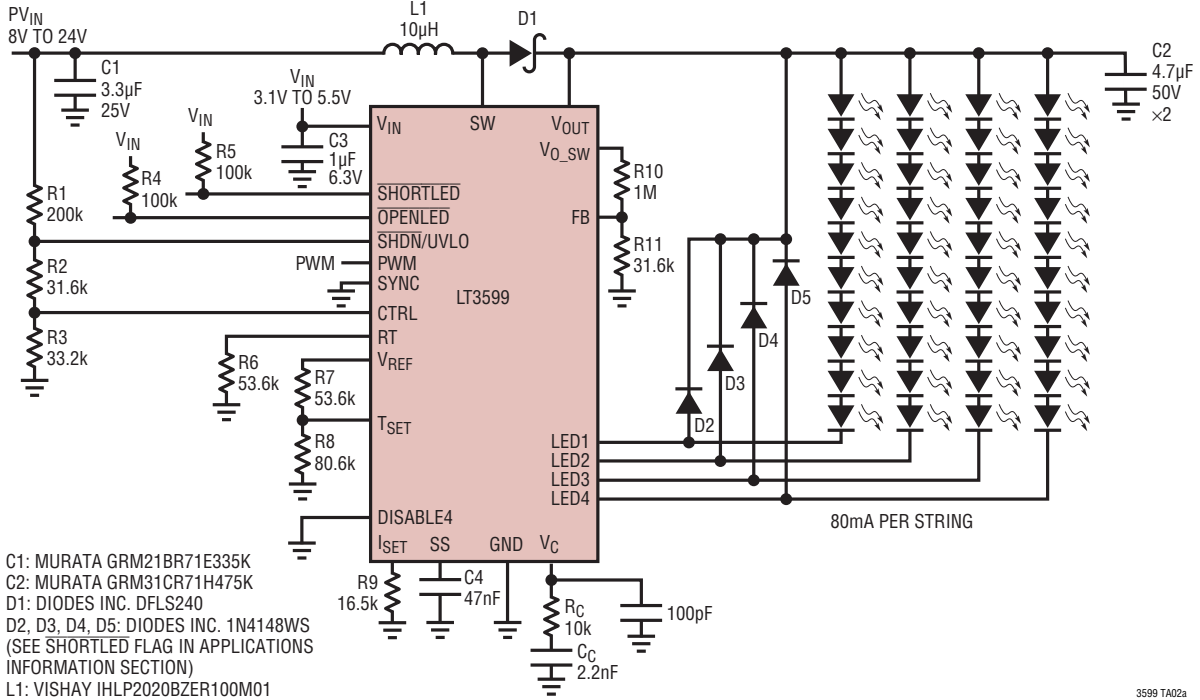

Figure 13. Recommended Component Placement

3599 F13

TYPICAL APPLICATIONS

12W LED Driver
1MHz Boost, 80mA per String, 10 LEDs per String



3599 TA02a

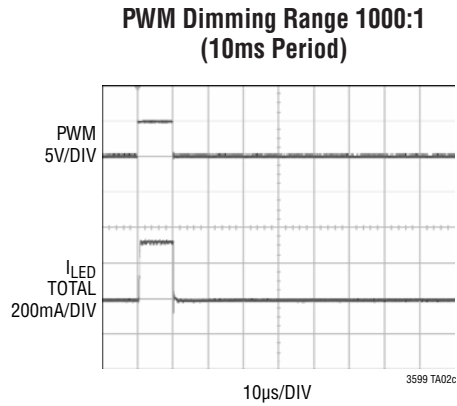
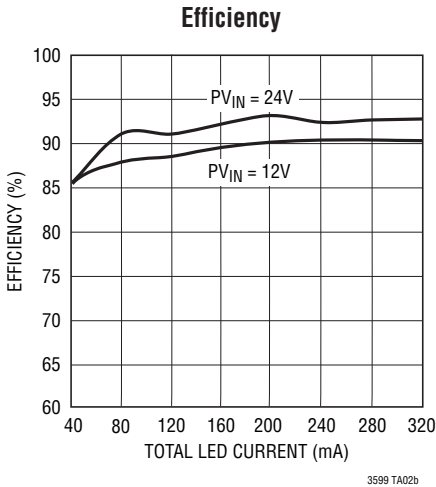

TYPICAL APPLICATIONS

12W LED Driver 400kHz Boost, Two LED Strings, 200mA per String, 8 LEDs per String

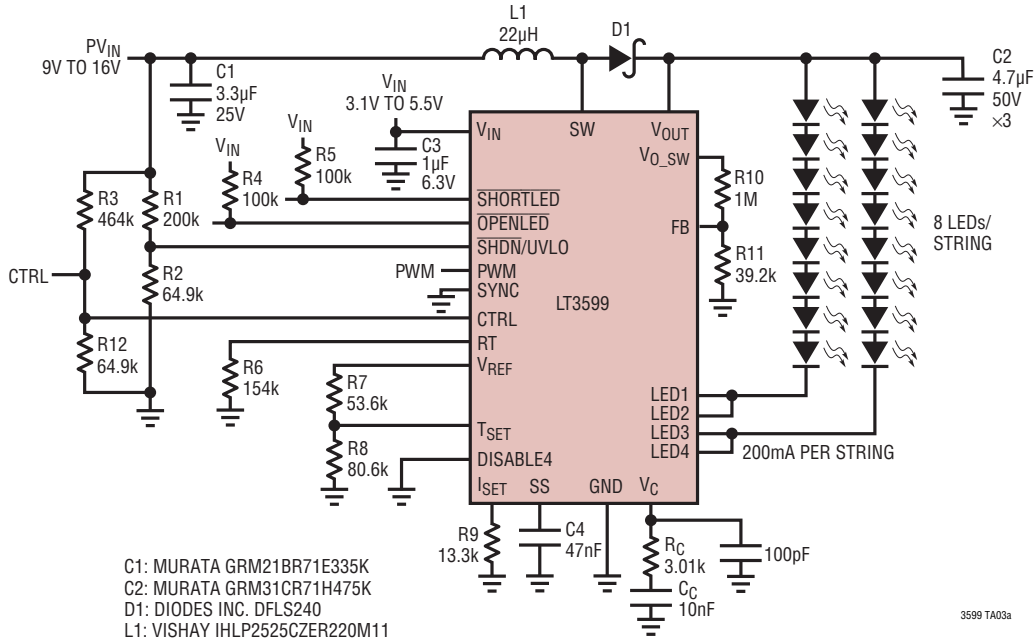

3599 TA03a

TYPICAL APPLICATIONS

7W LED Driver
SEPIC (Survives Output Short to Ground)
300kHz, Three Strings, 100mA per String, 6 LEDs per String

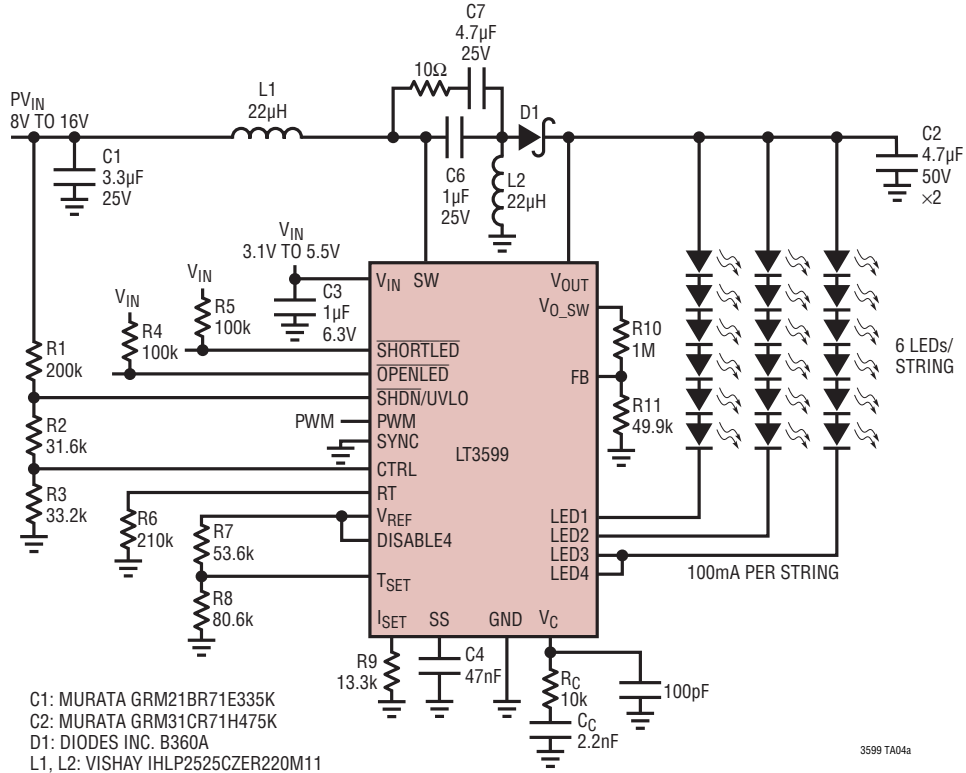

TYPICAL APPLICATIONS

8W LED Driver
2MHz Boost, Three Strings, 100mA per String, 7 LEDs per String

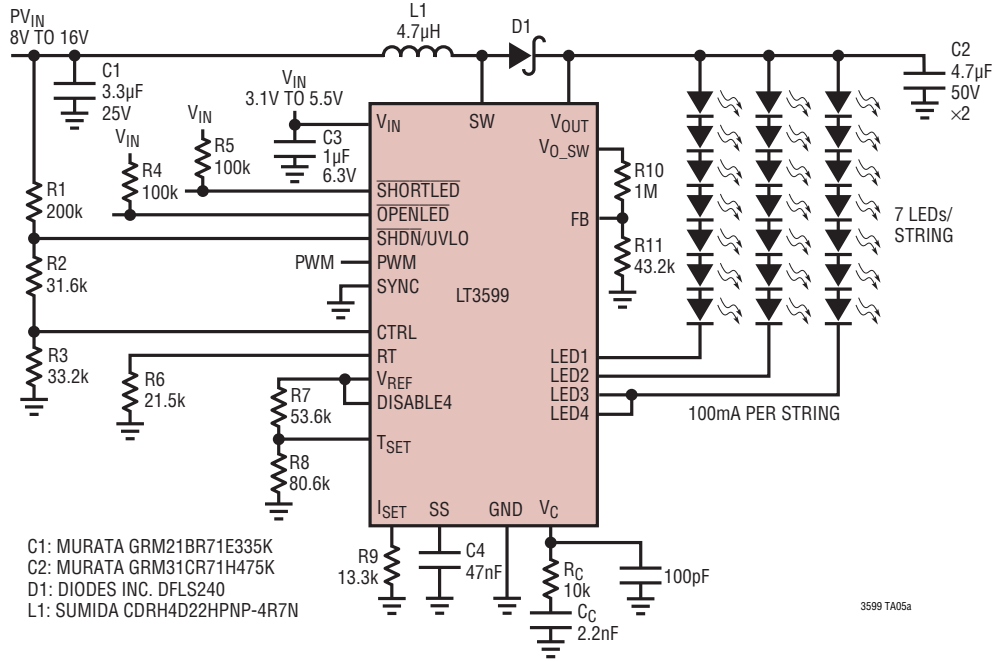

3599 TA05a

TYPICAL APPLICATIONS

2.1 MHz Boost, Four Strings, 80mA per String, 7 LEDs per String

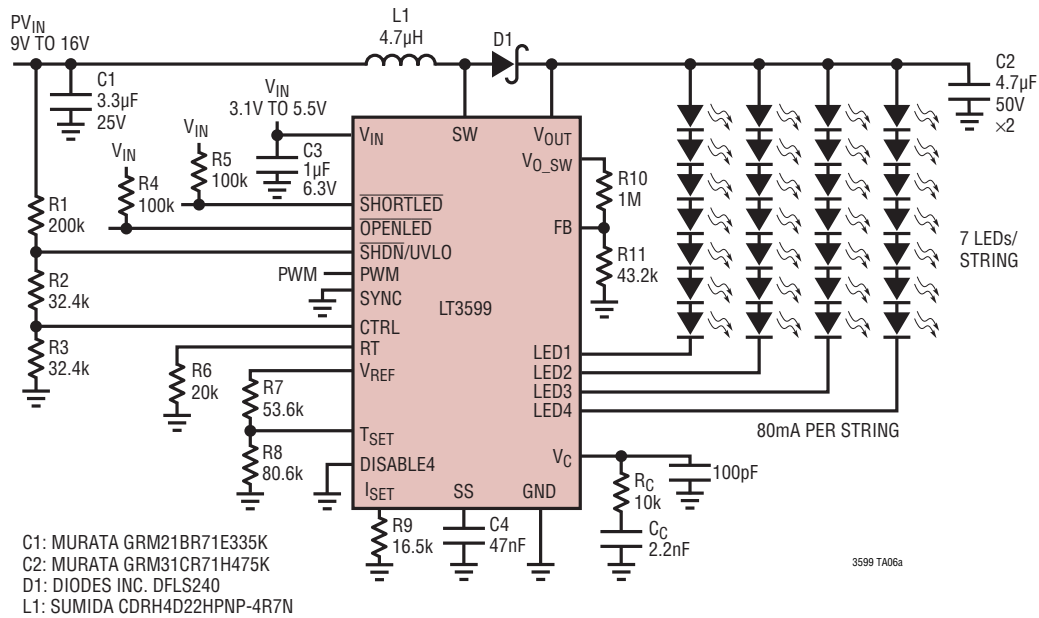

PWM Dimming 3000:1 (10ms Period)

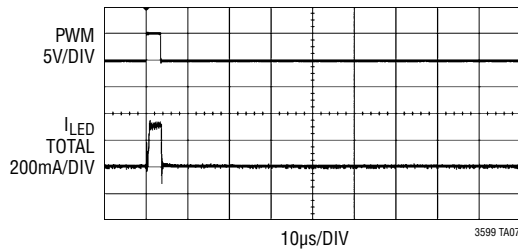

PACKAGE DESCRIPTION

Please refer to <http://www.linear.com/product/LT3599#packaging> for the most recent package drawings.

FE Package
28-Lead Plastic TSSOP (4.4mm)
 (Reference LTC DWG # 05-08-1663 Rev K)
Exposed Pad Variation EB

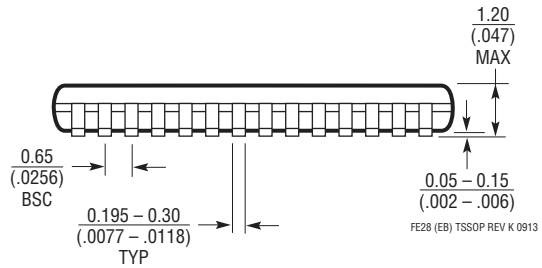
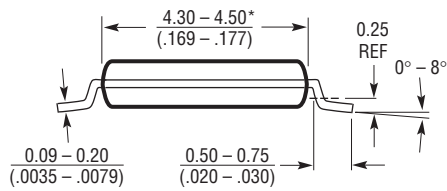
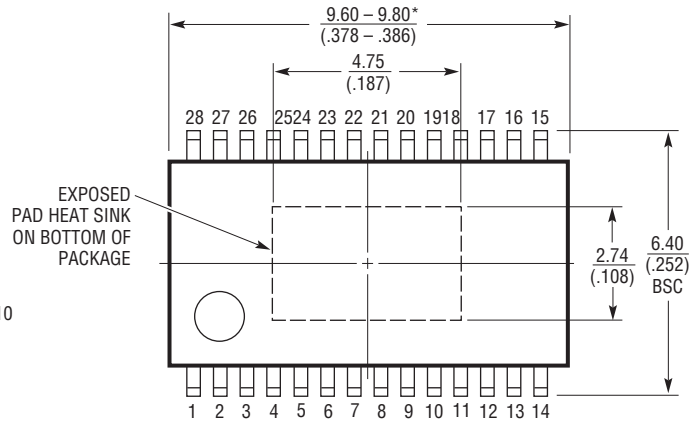
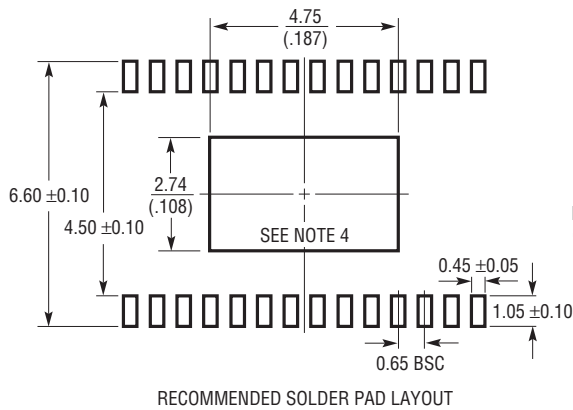

- NOTE:
1. CONTROLLING DIMENSION: MILLIMETERS
 2. DIMENSIONS ARE IN MILLIMETERS (INCHES)
 3. DRAWING NOT TO SCALE
 4. RECOMMENDED MINIMUM PCB METAL SIZE FOR EXPOSED PAD ATTACHMENT
- *DIMENSIONS DO NOT INCLUDE MOLD FLASH. MOLD FLASH SHALL NOT EXCEED 0.150mm (.006") PER SIDE

PACKAGE DESCRIPTION

Please refer to <http://www.linear.com/product/LT3599#packaging> for the most recent package drawings.

UH Package
32-Lead Plastic QFN (5mm × 5mm)
 (Reference LTC DWG # 05-08-1693 Rev D)

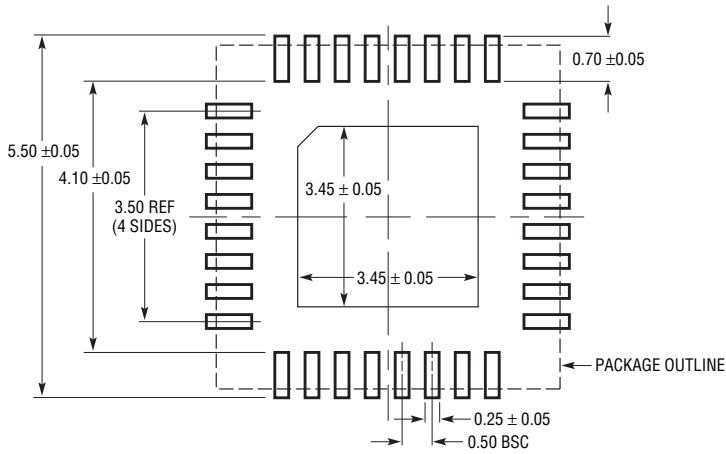

RECOMMENDED SOLDER PAD LAYOUT
 APPLY SOLDER MASK TO AREAS THAT ARE NOT SOLDERED

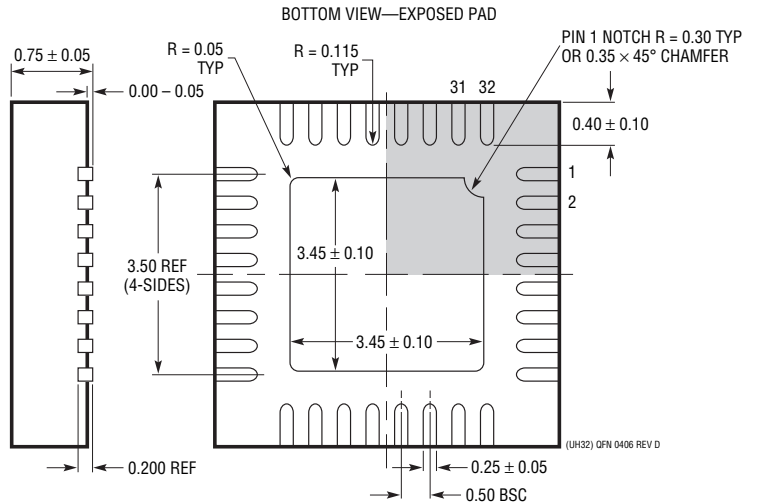
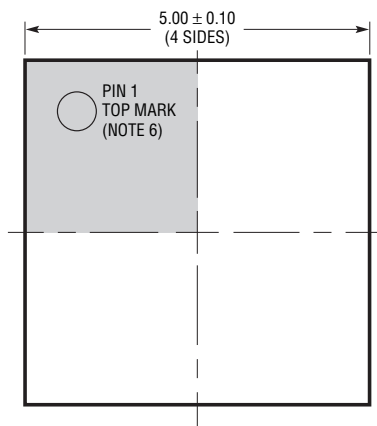

- NOTE:
1. DRAWING PROPOSED TO BE A JEDEC PACKAGE OUTLINE M0-220 VARIATION WHHD-(X) (TO BE APPROVED)
 2. DRAWING NOT TO SCALE
 3. ALL DIMENSIONS ARE IN MILLIMETERS
 4. DIMENSIONS OF EXPOSED PAD ON BOTTOM OF PACKAGE DO NOT INCLUDE MOLD FLASH. MOLD FLASH, IF PRESENT, SHALL NOT EXCEED 0.20mm ON ANY SIDE
 5. EXPOSED PAD SHALL BE SOLDER PLATED
 6. SHADED AREA IS ONLY A REFERENCE FOR PIN 1 LOCATION ON THE TOP AND BOTTOM OF PACKAGE

REVISION HISTORY (Revision history begins at Rev D)

REV	DATE	DESCRIPTION	PAGE NUMBER
D	01/10	Updated Typical Applications	1, 18, 19, 20, 21, 22
		Added H-Grade to Abs Max Ratings and Order Information	2
		Updated Typical Performance Characteristics	5, 6
		Revised Pin Functions	7
		Updated Table 6 and Deleted Text in Programming Switching Frequency Section	14
		Added to Related Parts Table	26
E	08/10	Updated FE package T_{JMAX}	2
		Updated Maximum Switch Duty Cycle Electrical Specifications	3
		Updated SYNC pin Electrical Specifications and Added H-grade information to Note 2	4
		Updated PWM Dimming Guidelines	12
		Updated SYNC timing description	15
		Updated $\overline{SHORTLED}$ FLAG description (clamp diodes)	16
		Updated Typical Application (clamp diodes example)	18
F	02/16	Changed the data sheet title from "4-Channel" to "4-String"	1
		Clarified the DISABLE4 pin function	7
		Clarified the Operations section	9
		Clarified the $\overline{SHORTLED}$ Flag section	16
		Clarified the Loop Compensation section	17
		Clarified the Related Parts Table	26

RELATED PARTS

PART NUMBER	DESCRIPTION	COMMENTS
LT3463/ LT3463A	Dual Output, Boost/Inverter, 250mA I_{SW} , Constant Off-Time, High Efficiency Step-Up DC/DC Converter with Integrated Schottkys	V_{IN} : 2.3V to 15V, $V_{OUT(MAX)} = \pm 40V$, $I_Q = 40\mu A$, $I_{SD} < 1\mu A$, 3mm \times 3mm DFN-10 Package
LT3466/ LT3466-1	Dual Constant Current, 2MHz, High Efficiency White LED Boost Regulator with Integrated Schottky Diode	V_{IN} : 2.7V to 24V, $V_{OUT(MAX)} = 40V$, $I_Q = 5\mu A$, $I_{SD} < 16\mu A$, 3mm \times 3mm DFN-10 Package
LT3474	36V, 1A (I_{LED}), 2MHz, Step-Down LED Driver	V_{IN} : 4V to 36V, $V_{OUT(MAX)} = 13.5V$, True Color PWM Dimming = 400:1, $I_{SD} < 1\mu A$, TSSOP-16E Package
LT3475	Dual 1.5A (I_{LED}), 36V, 2MHz, Step-Down LED Driver	V_{IN} : 4V to 36V, $V_{OUT(MAX)} = 13.5V$, True Color PWM Dimming = 3000:1, $I_{SD} < 1\mu A$, TSSOP-20E Package
LT3476	Quad Output 1.5A, 2MHz High Current LED Driver with 1000:1 Dimming	V_{IN} : 2.8V to 16V, $V_{OUT(MAX)} = 36V$, True Color PWM Dimming = 1000:1, $I_{SD} < 3\mu A$, 5mm \times 7mm QFN-10 Package
LT3477	3A, 42V, 3MHz Boost, Buck-Boost, Buck LED Driver	V_{IN} : 2.5V to 25V, $V_{OUT(MAX)} = 40V$, Dimming = Analog/PWM, $I_{SD} < 1\mu A$, QFN and TSSOP-20E Packages
LT3478/ LT3478-1	High Current LED Driver	V_{IN} : 2.8V to 36V, $V_{OUT(MAX)} = 42V$, True Color PWM Dimming = 3000:1, $I_{SD} < 10\mu A$, TSSOP-16E Package
LT3486	Dual 1.3A, 2MHz High Current LED Driver	V_{IN} : 2.5V to 24V, $V_{OUT(MAX)} = 36V$, True Color PWM Dimming = 1000:1, $I_{SD} < 1\mu A$, 5mm \times 3mm DFN and TSSOP-16E Packages
LT3496	45V, 2.1MHz 3-Channel ($I_{LED} = 1A$) Full Featured LED Driver	V_{IN} : 3V to 30V (40V $_{MAX}$), $V_{OUT(MAX)} = 45V$, True Color PWM Dimming = 3000:1, $I_{SD} < 1\mu A$, 4mm \times 5mm QFN-28 Package
LT3497	Dual 2.3MHz, Full Function LED Driver with Integrated Schottkys and 250:1 True Color PWM Dimming	V_{IN} : 2.5V to 10V, $V_{OUT(MAX)} = 32V$, $I_Q = 6mA$, $I_{SD} < 12\mu A$, 2mm \times 3mm DFN-10 Package
LT3498	2.3MHz, 20mA LED Driver and OLED Driver with Integrated Schottkys	V_{IN} : 2.5V to 12V, $V_{OUT(MAX)} = 32V$, $I_Q = 1.65mA$, $I_{SD} < 9\mu A$, 2mm \times 3mm DFN-12 Package
LT3518/ LT3517	2.3A/1.3A 45V, 2.5MHz Full Featured LED Driver with True Color PWM Dimming	V_{IN} : 3V to 30V (40V $_{MAX}$), $V_{OUT(MAX)} = 42V$, True Color PWM Dimming = 3000:1, $I_{SD} < 5\mu A$, 4mm \times 4mm QFN-16 Package
LT3590	48V Buck Mode LED Driver	V_{IN} : 4.5V to 55V, $V_{OUT(MAX)} = 5V$, $I_Q = 700\mu A$, $I_{SD} < 15\mu A$, 2mm \times 2mm DFN-6 and SC70 Packages
LT3591	Constant Current, 1MHz, High Efficiency White LED Boost Regulator with Integrated Schottky Diode and 80:1 True Color PWM Dimming	V_{IN} : 2.5V to 12V, $V_{OUT(MAX)} = 40V$, $I_Q = 4mA$, $I_{SD} < 9\mu A$, 2mm \times 3mm DFN-8 Package
LT3595	45V, 2.5MHz 16-Channel Full Featured LED Driver	V_{IN} : 4.5V to 45V, $V_{OUT(MAX)} = 45V$, True Color PWM Dimming = 5000:1, $I_{SD} < 1\mu A$, 5mm \times 9mm QFN-56 Package
LT3598	44V, 1.5A, 2.5MHz Boost 6-String LED Driver	V_{IN} : 3V to 30V, $V_{OUT(MAX)} = 44V$, True Color PWM Dimming = 3000:1, $I_{SD} < 1\mu A$, 4mm \times 4mm QFN-24 Package
LT3754	16-String \times 50mA LED Driver	V_{IN} : 6V to 40V, $V_{OUT(MAX)} = 60V$, 3,000:1 True Color PWM Dimming, $I_{SD} < 2\mu A$, 5mm \times 5mm QFN-32 Package
LT3760	8-String \times 100mA LED Driver	V_{IN} : 6V to 40V, $V_{OUT(MAX)} = 60V$, 3,000:1 True Color PWM Dimming, $I_{SD} < 2\mu A$, TSSOP-28E Package

Looking for pricing, stock, or lifecycle information?

Click below to explore more details on WIN SOURCE:

 [View LT3599EUH#PBF on WIN SOURCE](#)

 [Linear Technology](#) Information

Optimize Your Supply Chain with WIN SOURCE Solutions

-  Global Sourcing Solution
-  Obsolete Management
-  Cost Control Management
-  Shortage Management
-  Alternative Solution
-  Excess Inventory Management