



**THE DATASHEET OF
LT3909EMSE#PBF**



2-String × 60mA, 2MHz Step-Up LED Driver with ±2% Current Matching

FEATURES

- Up to 36V of LEDs, 2-String × 60mA LED Driver
- Wide Input Range: 2.9V to 40V
- Up to 40,000:1 PWM Dimming (250ns LED On-Time) (Independent of Leakage at V_{OUT})
- ±2% LED Current Matching (Typ ±0.3%)
- Integrated Schottky Diode
- Internal 400mΩ, 40V, 1A Switch
- Single Resistor Sets LED Current (10mA to 60mA) for Both High-Side Current Sources
- Output Adapts to LED V_F for Optimum Efficiency
- LED Current Regulated Even for $V_{IN} > V_{OUT}$
- Fault Flag + Protection for Open-LED and LED-Short-to-GND (Other String Remains in Regulation)
- Programmable Maximum V_{OUT} (Regulated)
- Internal Compensation, Soft-Start and Thermal Regulation
- Accurate EN/UVLO Threshold
- Fixed 2MHz Switching Frequency

APPLICATIONS

- PDAs, Handheld Computers
- GPS Receivers
- Automotive Displays
- High Contrast Instrument Clusters

DESCRIPTION

The **LT[®]3909** is a 2-string × 60mA LED driver with a fixed 2MHz step-up DC/DC converter capable of driving up to 36V of LEDs. Each LED string contains an accurate high-side current source with ±2% current matching. Output voltage adapts to variations in LED V_F for optimum efficiency.

Maximum LED current can be programmed from 10mA to 60mA per string using a single resistor. LED brightness can be reduced with analog dimming (up to 10:1) or with PWM dimming (up to 40,000:1 at 100Hz, up to 160:1 at 25kHz) (independent of leakage at V_{OUT}). The LED pins can be paralleled for higher LED current.

Additional features include: programmable maximum V_{OUT} for open LED protection, a fault flag to indicate open-LED or LED-short-to-GND and an internal regulation loop to safely limit junction temperature. The LT3909 also includes internal compensation, internal soft-start and micropower shutdown. The LT3909 is available in the 12-pin (3mm × 3mm) DFN and 12-pin MSOP packages.

LT, LT, LTC, LTM, Linear Technology and the Linear logo are registered trademarks of Linear Technology Corporation. All other trademarks are the property of their respective owners.

TYPICAL APPLICATION

2-String × 40mA, 2MHz LED Driver for Ten White LEDs/String

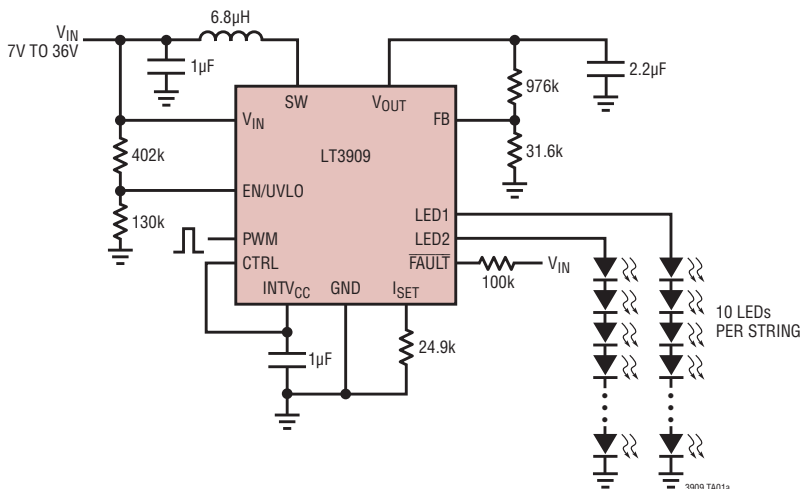

LED Current Waveforms
20,000:1 PWM Dimming (100Hz)

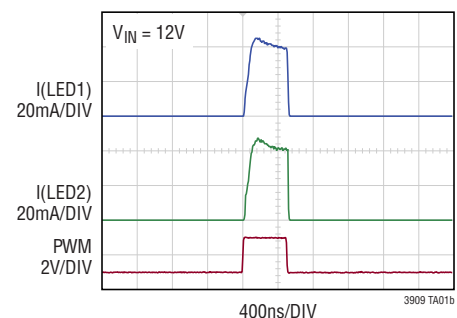

LT3909

ABSOLUTE MAXIMUM RATINGS (Note 1)

V_{IN} , V_{OUT} , SW	40V	Operating Junction Temperature (Notes 3, 4)	
LED1, LED2	40V	LT3909E, LT3909I	-40°C to 125°C
V_{OUT} – LED1, V_{OUT} – LED2	40V	Storage Temperature Range	-65°C to 150°C
EN/UVLO, FAULT	40V	Lead Temperature (Soldering, 10 sec)	
CTRL, FB, PWM	6V	MSOP Package Only	300°C
$INTV_{CC}$, I _{SET}	(Note 2)		

PIN CONFIGURATION

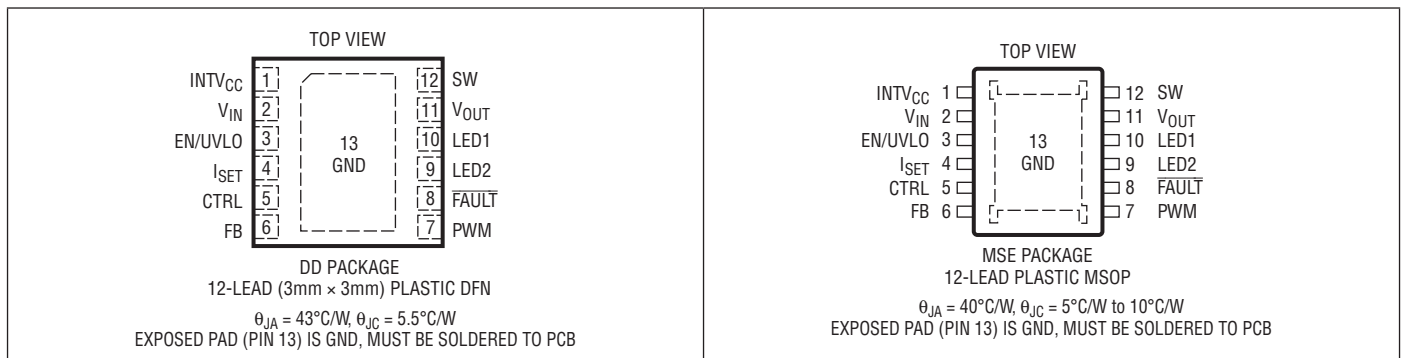

ORDER INFORMATION

(<http://www.linear.com/product/LT3909#orderinfo>)

LEAD FREE FINISH	TAPE AND REEL	PART MARKING*	PACKAGE DESCRIPTION	TEMPERATURE RANGE
LT3909EDD#PBF	LT3909EDD#TRPBF	LGMY	12-Lead (3mm × 3mm) Plastic DFN	-40°C to 125°C
LT3909IDD#PBF	LT3909IDD#TRPBF	LGMY	12-Lead (3mm × 3mm) Plastic DFN	-40°C to 125°C
LT3909EMSE#PBF	LT3909EMSE#TRPBF	3909	12-Lead Plastic MSOP	-40°C to 125°C
LT3909IMSE#PBF	LT3909IMSE#TRPBF	3909	12-Lead Plastic MSOP	-40°C to 125°C

Consult LTC Marketing for parts specified with wider operating temperature ranges. *The temperature grade is identified by a label on the shipping container.

For more information on lead free part marking, go to: <http://www.linear.com/leadfree/>

For more information on tape and reel specifications, go to: <http://www.linear.com/tapeandree/>. Some packages are available in 500 unit reels through designated sales channels with #TRMPBF suffix.

ELECTRICAL CHARACTERISTICS The ● denotes the specifications which apply over the full operating temperature range, otherwise specifications are at $T_A = 25^\circ\text{C}$. $V_{IN} = V_{EN/UVLO} = 12\text{V}$, $R_{ISET} = 49.9\text{k}$, $V_{OUT} = 24\text{V}$, unless otherwise noted.

PARAMETER	CONDITIONS		MIN	TYP	MAX	UNITS
Input, Bias, Reference						
Input Voltage Range		●	2.9		40	V
V_{IN} Quiescent Current (Not Switching)	$V_{OUT} - V_{LEDx} = 2\text{V}$, $V_{CTRL} = 2.0\text{V}$, $\text{PWM} = 1.5\text{V}$			600	700	μA
V_{IN} Shutdown Current	$V_{EN/UVLO} = 0.4\text{V}$, $V_{IN} = 12\text{V}$			0.3	2	μA
	$V_{EN/UVLO} = 0.4\text{V}$, $V_{IN} = 40\text{V}$			1.5	4	μA
Enable/Lockout Threshold						
EN/UVLO Shutdown Threshold	$I_{VIN} < 10\mu\text{A}$	●	0.4	0.6		V
EN/UVLO Enable Threshold	Falling	●	1.180	1.215	1.250	V
EN/UVLO Enable Hysteresis				30		mV
EN/UVLO Pin Current	$V_{EN/UVLO} = 0.4\text{V}$	●	1.6	0.8	2.4	μA
	$V_{EN/UVLO} = 1.15\text{V}$			2.0		μA
	$V_{EN/UVLO} = 1.3\text{V}$			0		μA
Linear Regulator (INTV_{CC})						
INTV _{CC} Regulation Voltage	$I_{INTVCC} = 0\text{A to } 100\mu\text{A}$	●	2.9	3.0	3.1	V
Oscillator						
Switching Frequency		●	1.88	2	2.12	MHz
f_{OSC} Line Regulation	$2.9\text{V} \leq V_{IN} \leq 40\text{V}$			0.02	0.1	%/V
Maximum Duty Cycle		●	86	91		%
LED Current/Control						
LEDx Current (20mA)	$V_{OUT} - V_{LEDx} = 1.1\text{V}$, $V_{CTRL} = 1.2\text{V}$, $R_{ISET} = 49.9\text{k}$	●	19.4	20	20.6	mA
Current Matching (20mA)	$V_{OUT} - V_{LEDx} = 1.1\text{V}$, $V_{CTRL} = 1.2\text{V}$, $R_{ISET} = 49.9\text{k}$	●		± 0.3	± 1.8	%
LEDx Current (50mA)	$V_{OUT} - V_{LEDx} = 1.1\text{V}$, $V_{CTRL} = 1.2\text{V}$, $R_{ISET} = 20.0\text{k}$	●	48.0	50	52.0	mA
Current Matching (50mA)	$V_{OUT} - V_{LEDx} = 1.1\text{V}$, $V_{CTRL} = 1.2\text{V}$, $R_{ISET} = 20.0\text{k}$	●		± 0.3	± 1.8	%
LEDx Current (60mA) (Note 5)	$V_{OUT} - V_{LEDx} = 1.1\text{V}$, $V_{CTRL} = 1.2\text{V}$, $R_{ISET} = 16.7\text{k}$	●	57.0	60	63.0	mA
Current Matching (60mA) (Note 5)	$V_{OUT} - V_{LEDx} = 1.1\text{V}$, $V_{CTRL} = 1.2\text{V}$, $R_{ISET} = 16.7\text{k}$	●		± 0.3	± 2.0	%
$V_{OUT} - V_{LEDx}$ Regulation				1.3		V
Analog Dimming						
CTRL Input Current (Out of Pin)	$V_{CTRL} = 1\text{V}$ $V_{CTRL} = 0.1\text{V}$			5	200	nA
				15	200	nA
CTRL Latch-Off Threshold	Falling		75	80	85	mV
CTRL Latch-Off Hysteresis	Rising			10		mV
LEDx Current (Dimming 10:1)	$V_{OUT} - V_{LEDx} = 1.1\text{V}$, $V_{CTRL} = 0.1\text{V}$, $R_{ISET} = 49.9\text{k}$		1.87	2.03	2.19	mA
PWM Dimming						
PWM Input Low Threshold		●	0.8	1.1		V
PWM Input High Threshold		●		1.2	1.5	V
PWM Resistance to GND				100		k Ω
LEDx Leakage Current (PWM = 0V)	$V_{LEDx} = 12\text{V}$, $V_{OUT} = 40\text{V}$			0.1	1	μA
Fault Diagnostics						
FAULT Output Low	$I_{FAULT} = 100\mu\text{A}$			0.1	0.2	V
FAULT Leakage Current	$V_{FAULT} = 5\text{V}$			0.1	1	μA

ELECTRICAL CHARACTERISTICS

The ● denotes the specifications which apply over the full operating temperature range, otherwise specifications are at $T_A = 25^\circ\text{C}$. $V_{IN} = V_{EN/UVLO} = 12\text{V}$, $R_{ISET} = 49.9\text{k}$, $V_{OUT} = 24\text{V}$, unless otherwise noted.

PARAMETER	CONDITIONS		MIN	TYP	MAX	UNITS
LEDx Short Threshold V_{LEDx} (Note 6)	V_{LEDx} Falling		5.8	6.0	6.2	V
LEDx Open Threshold ($V_{OUT} - V_{LEDx}$)	$(V_{OUT} - V_{LEDx})$ Falling			0.3	0.4	V
Output Voltage						
FB Regulation Voltage		●	1.190	1.215	1.240	V
FB Input Current (Out of Pin)	$V_{FB} = 1.215\text{V}$	●	-100		100	nA
Switch						
Switch Current Limit		●	1.0	1.1	1.2	A
Switch On-Resistance	$I_{SW} = 100\text{mA}$			400		m Ω
Switch Leakage Current	$V_{SW} = 40\text{V}$, $V_{OUT} = 40\text{V}$				2	μA
Schottky Diode						
Schottky Forward Voltage	$I_{SCHOTTKY} = 250\text{mA}$			0.8		V

Note 1: Stresses beyond those listed under Absolute Maximum Ratings may cause permanent damage to the device. Exposure to any Absolute Maximum Rating condition for extended periods may affect device reliability and lifetime.

Note 2: Do not apply a positive or negative voltage to $INTV_{CC}$ or I_{SET} pins, otherwise permanent damage may occur.

Note 3: The LT3909 includes overtemperature protection that is intended to protect the device during momentary overload conditions. Junction temperature will exceed 150°C when overtemperature protection is active. Continuous operation above the specified maximum operating junction temperature may impair device reliability.

Note 4: The LT3909E is guaranteed to meet performance specifications from 0°C to 125°C junction temperature. Specifications over the -40°C to 125°C operating junction temperature range are assured by design, characterization and correlation with statistical process controls. The LT3909I is guaranteed over the full -40°C to 125°C operating junction temperature range. High junction temperatures degrade operating lifetimes. Operating lifetime is derated at junction temperatures greater than 125°C .

Note 5: The 16.7k is a 0.1% resistor to achieve exactly 60mA LED current.

Note 6: The LED short threshold refers to the LED pin voltage with respect to GND. This threshold is approximately 25% of V_{OUT} regulation level. When V_{LEDx} voltage falls below this threshold, the FAULT pin is asserted.

TYPICAL PERFORMANCE CHARACTERISTICS $T_A = 25^\circ\text{C}$, unless otherwise noted.

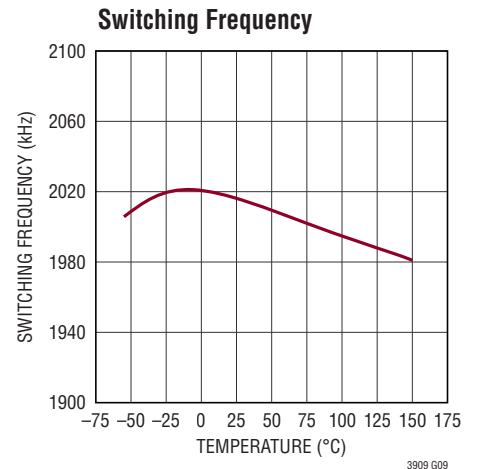
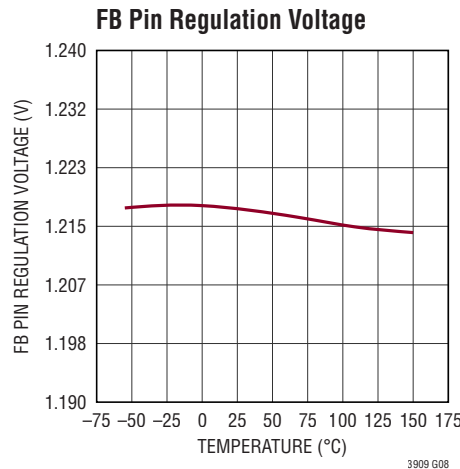
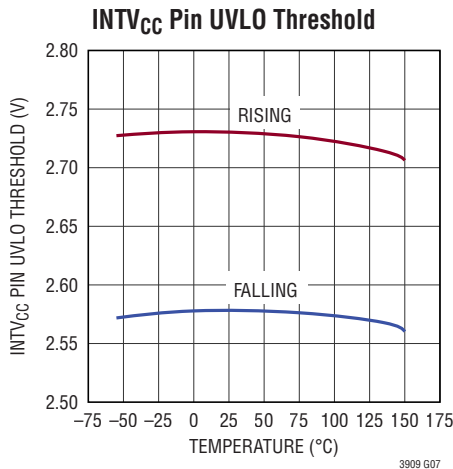
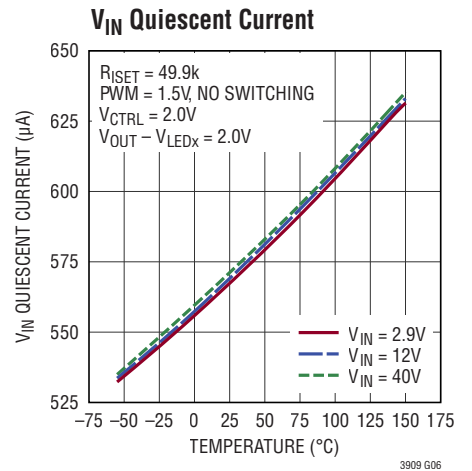
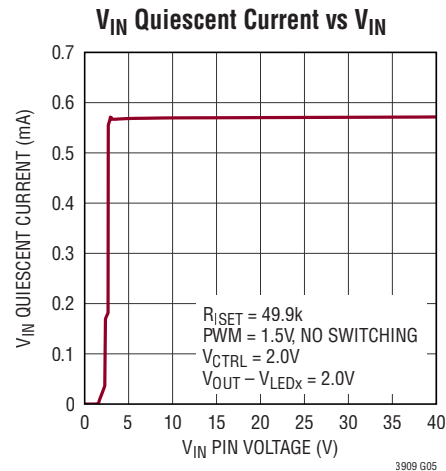
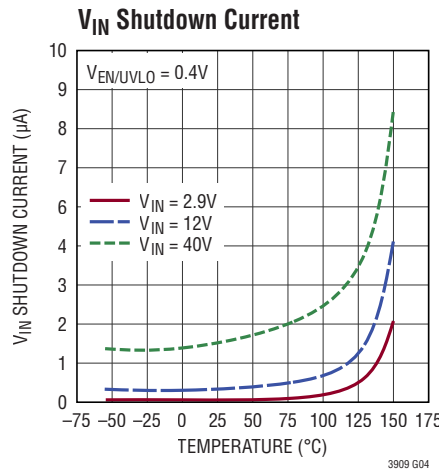
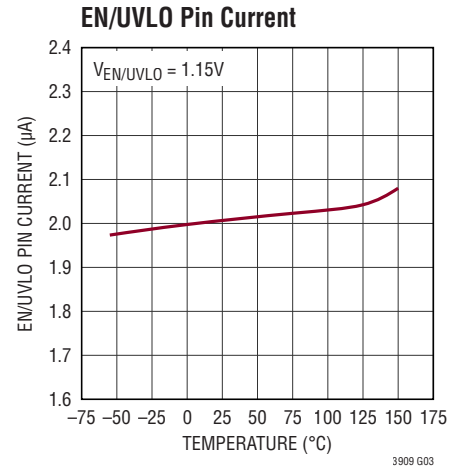
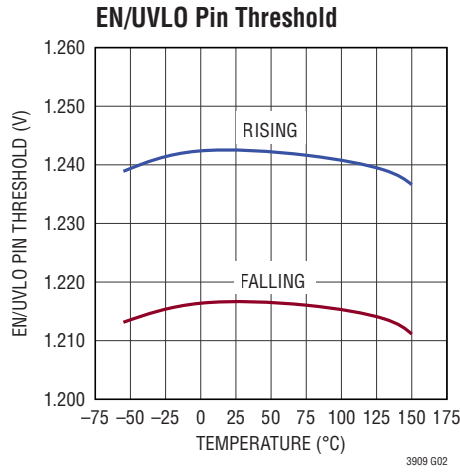
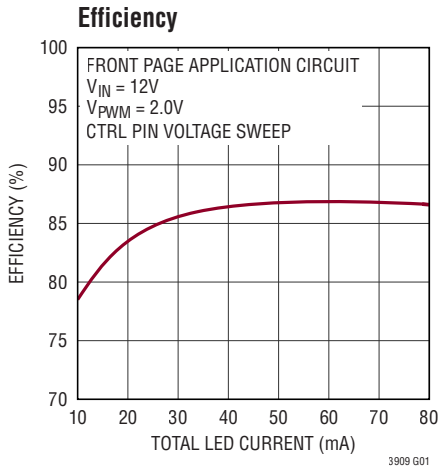

TYPICAL PERFORMANCE CHARACTERISTICS $T_A = 25^\circ\text{C}$, unless otherwise noted.

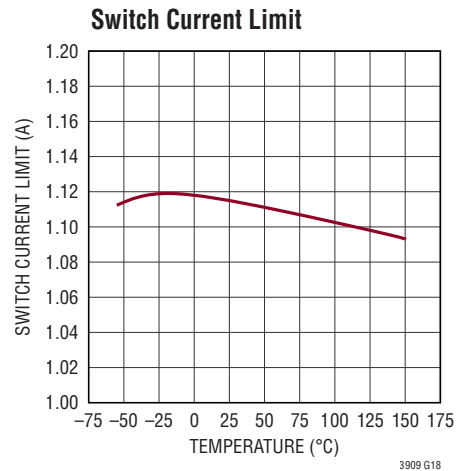
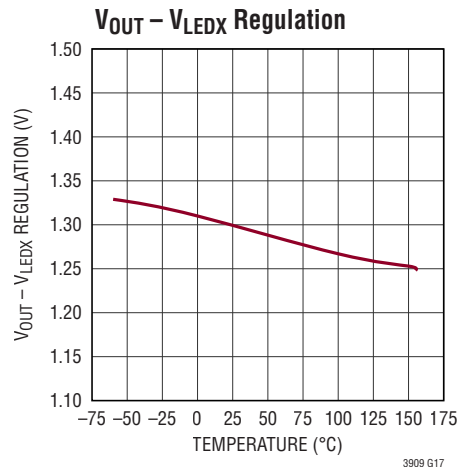
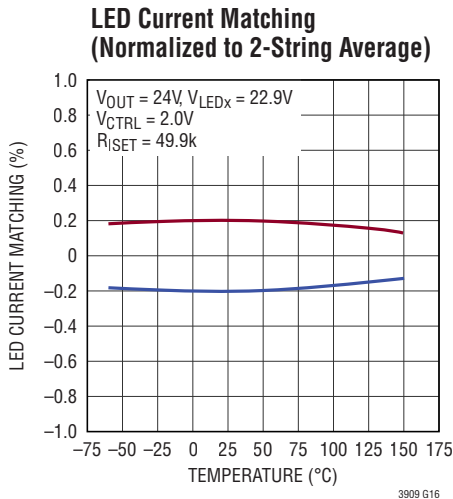
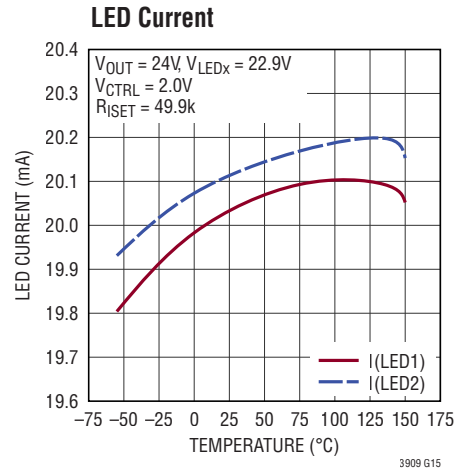
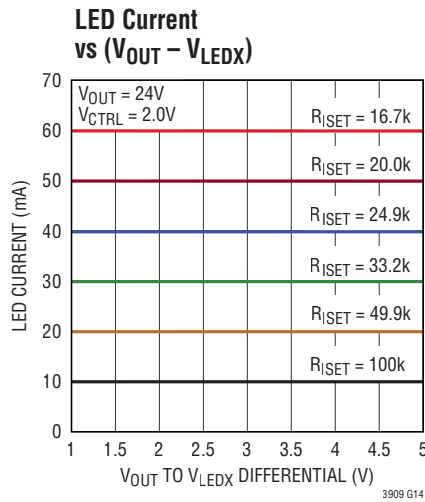
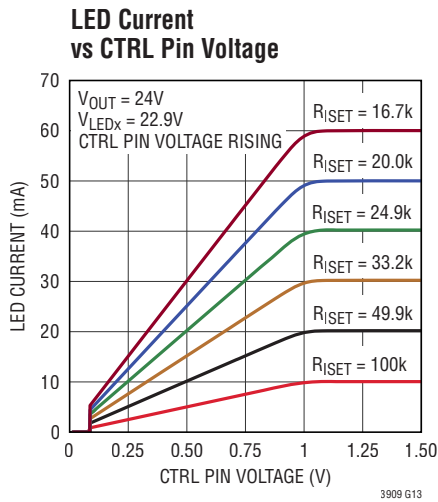
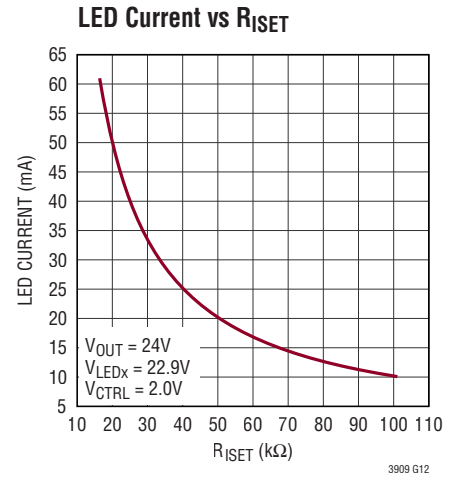
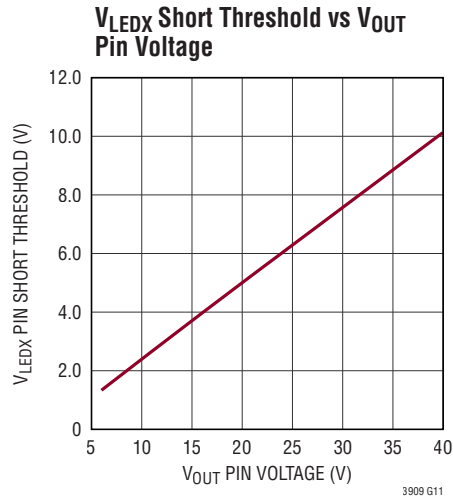
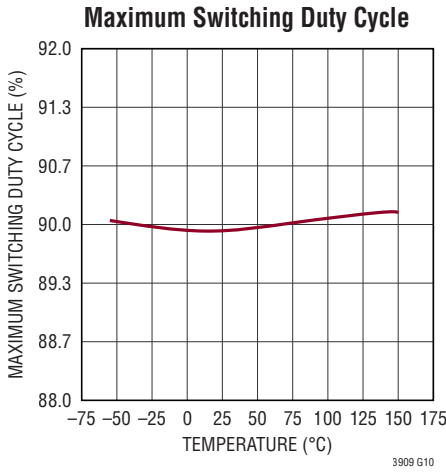

TYPICAL PERFORMANCE CHARACTERISTICS $T_A = 25^\circ\text{C}$, unless otherwise noted.

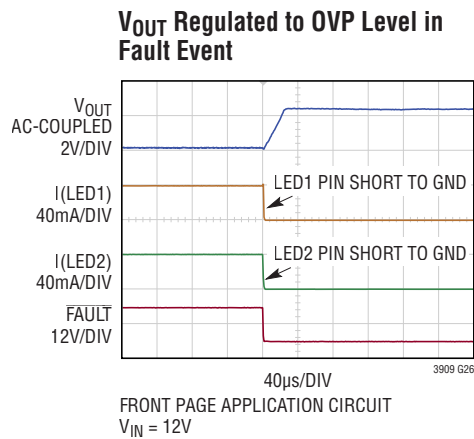
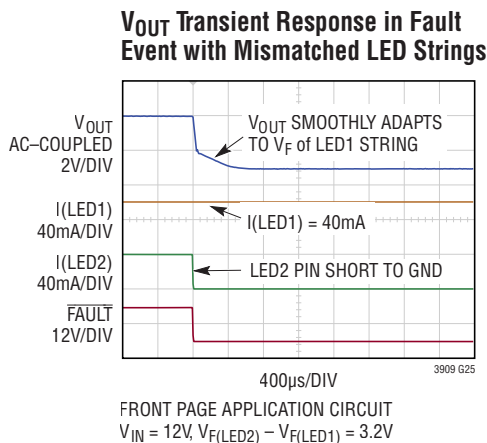
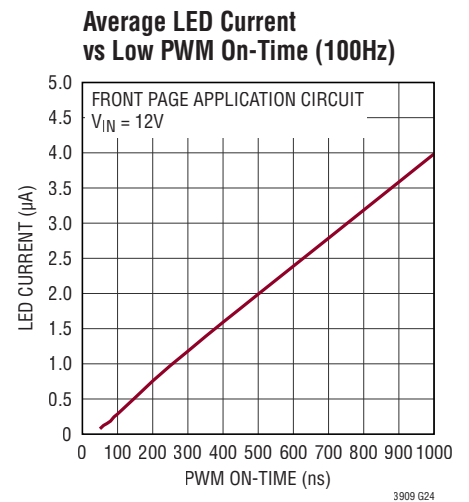
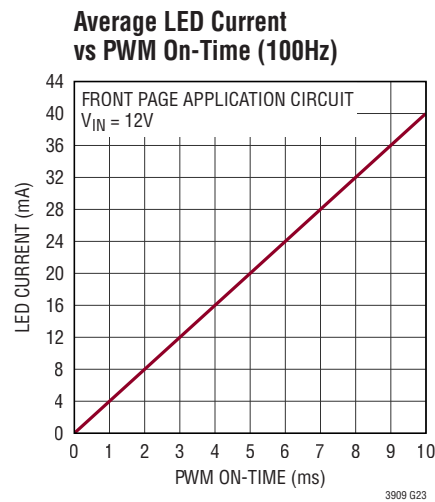
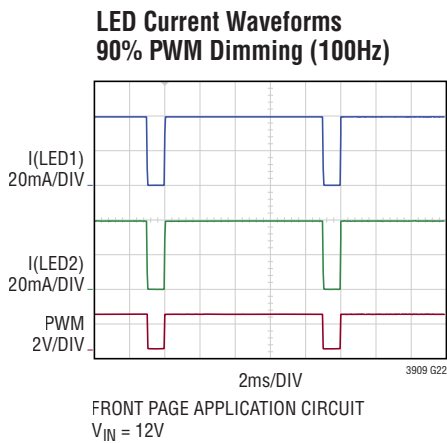
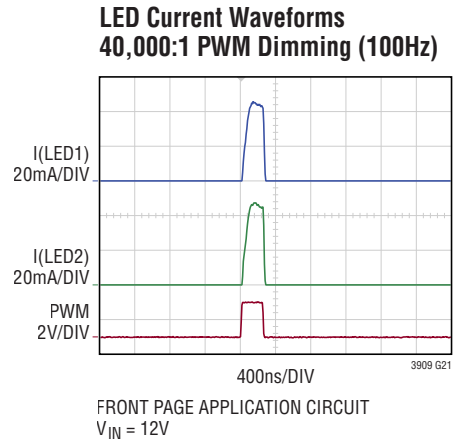
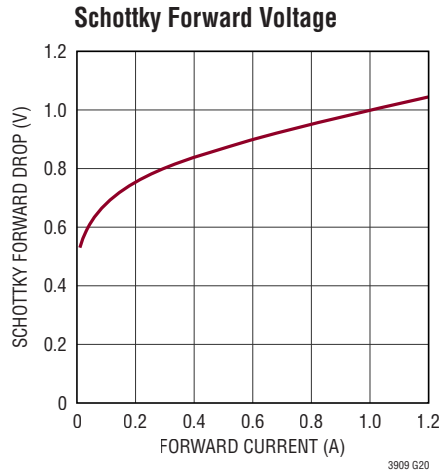
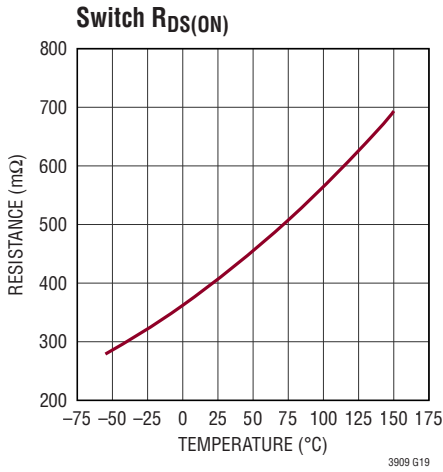

PIN FUNCTIONS

INTV_{CC} (Pin 1): Internal 3.0V Regulator Bypass Pin. The internal gate driver and control circuits are powered from this voltage. Use this pin only for PWM pin connection, resistor divider setting CTRL pin voltage, and pull-up resistor at $\overline{\text{FAULT}}$ pin. When used, the total current drained from the INTV_{CC} pin should be kept <100 μ A. Decouple this pin to power ground with at least 1 μ F low ESR ceramic capacitor placed close to the IC.

V_{IN} (Pin 2): Input Supply Pin. Must be locally bypassed with a capacitor to ground.

EN/UVLO (Pin 3): Enable and Undervoltage Lockout Pin. Pull the pin below 0.4V to shut down the LT3909 for lowest V_{IN} current. This pin has an accurate 1.215V (typical) falling threshold and programs V_{IN} undervoltage lockout (UVLO) threshold with an external resistor divider from V_{IN} to ground. A 2.0 μ A pin current hysteresis programs V_{IN} UVLO hysteresis. If neither function is used, tie this pin directly to V_{IN}.

I_{SET} (Pin 4): LED Current Setting Pin. A resistor to ground programs LED current for each string from 10mA to 60mA. See more details in the Applications Information section.

CTRL (Pin 5): LED Current Control Pin. CTRL pin voltage below 1V controls maximum LED current. If the CTRL pin voltage is below 80mV (typical), the LED current will be turned off. CTRL pin voltage can be set by a resistor divider from an external voltage source, V_{IN} or INTV_{CC}. Tie the CTRL pin to the INTV_{CC} pin if not used.

FB (Pin 6): Voltage Regulation Loop Feedback Pin. A resistor divider from V_{OUT} to GND, connected to the FB pin, programs maximum allowable V_{OUT} (regulated) when both LED strings experience either an open-LED or LED-short-to-GND fault, or when the CTRL pin voltage is below a latch-off threshold of 80mV. In addition, the LT3909 samples V_{OUT} through the resistor divider during PWM

pin on time and regulates V_{OUT} to an optimum level during PWM pin off time. V_{OUT} does not droop during PWM pin off time due to leakage from the Schottky diode or other sources. This enables up to 40,000:1 PWM dimming.

PWM (Pin 7): PWM Dimming Control Pin. A low signal turns off the high-side current sources to each LED string. Connect to the INTV_{CC} pin if not used.

$\overline{\text{FAULT}}$ (Pin 8): LED Fault Flag Pin. Connect a pull-up resistor from this pin to V_{IN}, INTV_{CC}, V_{OUT} or an external voltage source. Limit the current into the pin to no more than 100 μ A. The pin is active low if one or both LED strings have an open-LED or LED-short-to-GND fault. If a fault(s) clears, $\overline{\text{FAULT}}$ flag returns high. Fault status is only updated during PWM and CTRL high state and latched during PWM or CTRL low.

LED1-2 (Pins 9, 10): LED Driver Output Pin. Each output contains an open drain constant current source. LED currents are programmable from 10mA to 60mA using a single resistor at the I_{SET} pin. Connect the anode of each LED string to an LED pin. Connect the cathode of each LED string to any available ground. LED pins can be paralleled for higher LED current.

V_{OUT} (Pin 11): Output Pin. Connect a capacitor from this pin to ground.

SW (Pin 12): Switch Pin. Drain of the internal power switch and anode of the internal Schottky diode. Connect the inductor to this pin and minimize the PCB trace area at this pin to minimize EMI.

Exposed Pad (Pin 13): Ground Pin. Both DFN and MSOP packages have an exposed pad (Pin 13) underneath the IC for enhanced heat dissipation. Pin 13 should be soldered to a continuous copper ground plane under the device to reduce die temperature and increase the thermal capability of the LT3909.

BLOCK DIAGRAM

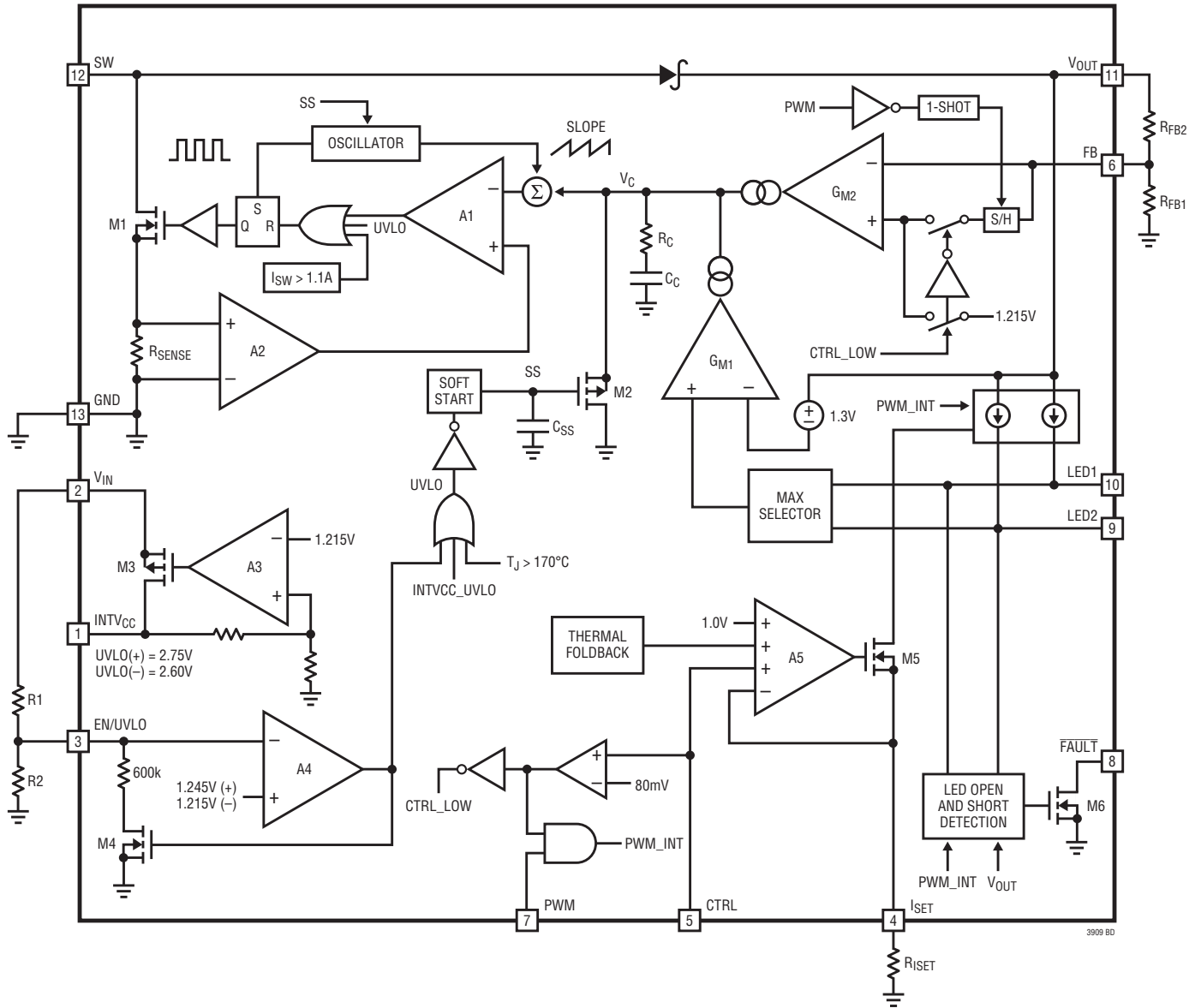

3909 BD

OPERATION

The LT3909 integrates a constant-frequency, current-mode boost converter with two high-side current sources. Each high-side current source regulates and modulates the current in each LED string. For optimum efficiency, V_{OUT} is regulated to the lowest possible voltage required to maintain those regulated currents in each LED string. Operation is best understood by referring to the typical application circuit on the front page and the Block Diagram.

Start-Up

The LT3909 enters shutdown mode and draws almost zero current when the EN/UVLO pin is lower than 0.6V (typical). Once the EN/UVLO pin is above 0.6V, the part starts to wake up internal bias currents, generates various references, and charges the INTV_{CC} pin towards a 3.0V regulation voltage.

For the LT3909 to exit undervoltage lockout (UVLO) mode, EN/UVLO pin needs to be above 1.245V and INTV_{CC} pin needs to be above 2.75V. A 1.215V falling threshold on the EN/UVLO pin, combined with an EN/UVLO pin current hysteresis, allows a programmable resistor divider from V_{IN} to EN/UVLO to define the UVLO threshold for V_{IN} . EN/UVLO pin current switches from 2.0 μ A to 0 μ A when EN/UVLO pin voltage exceeds 1.245V.

After exiting UVLO, if the PWM pin voltage is high, the boost converter enables switching action, and the internal soft-start node is charged up, thereby smoothly ramping up the inductor current. During the soft-start period, the switching frequency also gradually ramps up from approximately 15% of full-scale, and immediately steps up to 100% of full-scale once the soft-start period ends.

Constant Current Source

Each string has a local current source regulating its own LED current. These high-side current sources are connected between the V_{OUT} pin and each LED pin. With the top LED in each string (anode) connected to the LED pin and the bottom LED (cathode) connected to any available ground, this high-side current source structure allows a simple one wire LED connection per LED string.

LED Current Modulation and Regulation

LED current programming and dimming is achieved using the I_{SET}, CTRL and PWM pins. A single resistor at the I_{SET} pin programs LED current between 10mA to 60mA. Analog dimming of LED brightness is achieved using the CTRL pin below 1V. PWM dimming of LED brightness is achieved by controlling the duty cycle of the PWM pin. LED pins can be paralleled to achieve higher LED currents. For applications requiring only 1 string of LEDs, parallel both LED pins and program for half of the full current.

Fault Detection and Protection

The LT3909 monitors the voltage drop across each high-side current source and also each LED pin voltage. If an LED string has an open-LED fault [$(V_{OUT} - V_{LEDx}) < 0.3V$] or an LED-short-to-GND fault ($V_{LEDx} < 0.25 \cdot V_{OUT}$), the FAULT flag is pulled low, and the remaining LED string is not affected.

For LED protection, the LT3909 CTRL pin allows an LED current derating curve as a function of LED ambient temperature. An NTC resistor placed close to the LEDs decreases the CTRL pin voltage and hence decreases LED current as LED ambient temperature increases (see Figure 5). The LT3909 also features an internal thermal regulation loop to regulate its own maximum junction temperature by derating LED currents.

Boost Converter Operation

The LT3909 has an internal N-channel DMOS power switch and an internal Schottky diode to generate a boosted output voltage V_{OUT} using a single inductor and an output capacitor.

For optimum efficiency, V_{OUT} is regulated to the lowest possible voltage required to maintain regulated current in each LED string. This is achieved by the GM1 loop, which monitors and regulates the lower voltage drop across the two high-side current sources (between V_{OUT} and each LED pin) to 1.3V. If one of the LED strings has an open-LED or LED-short-to-GND fault, the LT3909 regulation loop will ignore the LED pin with the fault.

OPERATION

When both of the LED strings have either an open-LED or LED-short-to-GND fault, V_{OUT} charges up until a user programmable OVP (overvoltage protection) level is reached. This programmable OVP level allows the user to protect against LED damage when the LED strings are open and then reconnected. The OVP regulation is implemented by the GM2 loop, which regulates the FB pin voltage to 1.215V. The GM2 loop is also activated during the PWM low periods when PWM Dimming is applied. During PWM high, V_{OUT} is regulated to the optimum level for the LED driver. At the PWM low edge, the FB pin voltage is sampled to store that optimum V_{OUT} level. V_{OUT} is then regulated during PWM off time to maintain the optimum V_{OUT} level. This regulation of V_{OUT} during PWM off time prevents V_{OUT} droop due to leakages. This allows fast LED current recovery at the rising edge of the PWM dimming pulse.

Since the LT3909 boost converter uses a peak current mode topology, the V_C node voltage determines the peak current in the inductor and hence the duty cycle of the SW pin switching waveform. The basic loop uses a pulse from an internal oscillator to set an RS flip-flop and turn on the internal power switch. Current increases in the switch and the inductor until the V_C commanded peak switch current is exceeded and the switch is then turned off. As with all peak current mode converters, slope compensation is added to the control path to ensure stability for duty cycles above 50%. The LT3909 features an accurate 1.1A cycle-by-cycle current limit for the protection of the internal switch, the internal Schottky diode and the inductor. If this current limit is exceeded, the SR latch is reset regardless of the state of A1.

APPLICATIONS INFORMATION

Inductor Selection

Inductors with values between 3.3 μ H and 10 μ H will suffice for most LT3909 applications. Choose an inductor that can handle the necessary peak current without saturating. Also ensure that the inductor has low core losses at 2MHz and a low DCR (copper-wire resistance) to obtain the best efficiency. Table 1 lists several inductors that work well with the LT3909. However, there are many other manufacturers and inductors that can be used. Consult each manufacturer for more detailed information and their entire range of parts.

Input and Output Capacitor Selections

The input capacitor for the LT3909 boost converter will supply the transient input current of the power inductor. A 50V, 1.0 μ F input capacitor is sufficient for most LT3909 applications. Use only X5R or X7R ceramic capacitors to minimize variation over voltage and temperature. If the IC is required to operate near the minimum operational V_{IN} , a larger capacitor value may be required. This is to prevent excessive input voltage ripple from causing dips below the minimum operating input voltage. The output capacitor at the LT3909 boost converter output should

be a low ESR ceramic capacitor, to minimize output ripple voltage. Use only X5R or X7R ceramic capacitors as they retain their capacitance over wider voltage and temperature ranges than other dielectrics. A 50V, 1 μ F output capacitor is recommended for $V_{OUT} < 20V$ applications, and a 50V, 2.2 μ F output capacitor for $V_{OUT} > 20V$ applications. Table 2 shows a list of several recommended 50V capacitors. Consult the manufacturer for more detailed information and their entire range of parts.

Schottky Diode

The LT3909 has a built-in Schottky diode. The internal Schottky saves PCB area in space constrained applications. For better efficiency, an external Schottky diode can be connected between the SW node and the V_{OUT} node. It is important to use a properly rated Schottky diode that can handle the peak switch current of the LT3909. In addition, the Schottky diode must have a breakdown voltage of at least 40V along with a low forward voltage in order to achieve higher efficiency. One recommended external Schottky diode for the LT3909 is the Diodes Inc. SBR1A40S3.

APPLICATIONS INFORMATION

Shutdown and Programming Undervoltage Lockout

The LT3909 has an accurate 1.215V shutdown threshold at the EN/UVLO pin. This threshold can be used in conjunction with a resistor divider from the system input supply to define an accurate undervoltage lockout (UVLO) threshold for the system (Figure 1). An internal hysteresis voltage (30mV) and current (2.0μA) at the EN/UVLO pin allows programming of hysteresis voltage for this UVLO threshold. Calculation of the turn on/off thresholds for a system input supply using the LT3909 EN/UVLO pin is as follows:

$$V_{\text{SUPPLY(OFF)}} = 1.215\text{V} \cdot \left(1 + \frac{R1}{R2}\right)$$

$$V_{\text{SUPPLY(ON)}} = 1.245\text{V} \cdot \left(1 + \frac{R1}{R2}\right) + (2.0\mu\text{A} \cdot R1)$$

An open drain transistor can be added to the resistor divider network at the EN/UVLO pin to independently control the turn-off of the LT3909.

INTV_{CC} Regulator Bypassing and Operation

The INTV_{CC} pin is the output of an internal linear regulator driven from V_{IN} and is the supply for the internal gate driver and control circuits. The INTV_{CC} pin should be bypassed with a 4V or higher rated 1.0μF low ESR, X7R or X5R ceramic capacitor to ensure stability and provide charge for the gate driver. For V_{IN} ≥ 3.3V, the INTV_{CC} pin provides a regulated 3V supply. The INTV_{CC} regulator has

an undervoltage lockout which prevents gate driver switching until INTV_{CC} reaches 2.75V and maintains switching until INTV_{CC} falls below 2.6V.

Table 1. Recommended Inductors

PART	L (μH)	MAX DCR (Ω)	CURRENT RATING (A)	VENDOR
74437324100	10	0.243	1.5	Würth Elektronik www.we-online.com
74437324082	8.2	0.180	1.6	
74437324068	6.8	0.172	1.75	
74437324056	5.6	0.125	2.0	
74437324047	4.7	0.105	2.2	
74437324033	3.3	0.076	2.5	
LPS5030-103MR	10	0.127	1.4	Coilcraft www.coilcraft.com
LPS5030-822MR	8.2	0.125	1.6	
LPS5030-682MR	6.8	0.099	1.6	
LPS5030-562MR	5.6	0.089	1.8	
VLCF5020T-100MR87	10	0.182	1.56	TDK www.tdk.com
VLF5014ST-6R8M1R4	6.8	0.2	1.6	
VLF5014ST-4R7M1R7	4.7	0.12	2.0	

Table 2. Recommended Output Capacitors

PART	C (μF)	VOLTAGE	TEMP.	VENDOR
C2012X7R1H105K085AC	1.0	50V	X7R	TDK www.tdk.com
C3216X7R1H225K160AB	2.2	50V	X7R	
GJ821BR71H105KA12#	1.0	50V	X7R	Murata www.murata.com
GRM31CR71H225KA88#	2.2	50V	X7R	

The INTV_{CC} regulator is not intended to supply external circuitry, except for PWM pin connection, resistor divider setting CTRL pin voltage, and pull-up resistor at the FAULT pin. When used, the total current drained from the INTV_{CC} pin should be kept <100μA.

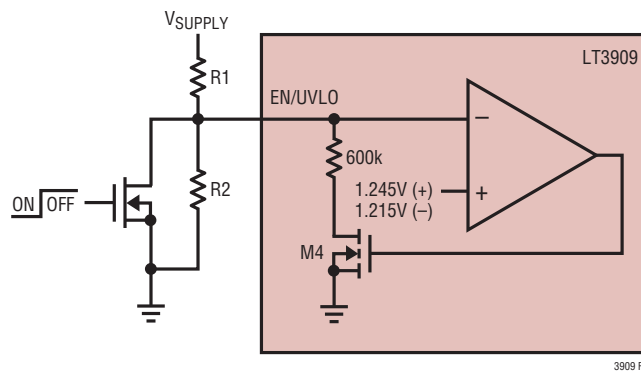

Figure 1. Programming Undervoltage Lockout with Hysteresis

APPLICATIONS INFORMATION

Programming LED Current

The current source at each LED pin is programmed using a single resistor, R_{ISET} , connected from the I_{SET} pin to ground according to the following equation:

$$I_{LEDx} = \frac{1000}{R_{ISET}} (A), (CTRL > 1.1V)$$

See Table 3 for resistor values and corresponding programmed LED current.

Table 3. LED Current vs R_{ISET}
(1% Resistors Unless Otherwise Noted)

LED CURRENT PER STRING (mA)	R_{ISET} (k Ω)
10	100
20	49.9
30	33.2
40	24.9
50	20.0
60	16.7 (0.1% Resistor)

Analog Dimming

The LT3909 allows for LED brightness control by analog dimming or by PWM dimming. Analog dimming uses the CTRL pin voltage below 1V to reduce LED current. For a CTRL pin voltage below 1V, the current in each LED pin is given by:

$$I_{LEDx} \approx CTRL \cdot \frac{1000}{R_{ISET}}, (0.1V < CTRL < 1V)$$

$$I_{LEDx} = 0 \text{ for } CTRL < 80mV$$

When changing the CTRL pin voltage for analog dimming, especially when ramping up, use $<10mV/\mu s$ slew rate to avoid errant faults. The LT3909 CTRL pin has a latch-off threshold (80mV typical), below which the current sources are turned off and the LT3909 regulation loop will regulate V_{OUT} to the programmed OVP level. If analog dimming is not required, the CTRL pin can be directly connected to the $INTV_{CC}$ pin. Using analog dimming to reduce LED current, in order to reduce LED brightness, also changes the perceived color of the LED.

PWM Dimming

Many applications require an accurate control of the brightness of the LED(s). In addition, being able to maintain a constant color over the entire dimming range can be just as critical. For constant color LED dimming the LT3909 provides a PWM pin to achieve up to a 40,000:1 wide PWM dimming range at 100Hz. This is achieved by operating the LED string at its programmed current and then controlling the on-time of that LED current. The duty cycle of the PWM pin controls the on-time of each LED pin current source (Figure 2). For maximum PWM dimming ratios (low PWM duty cycles) it is important to be able to turn LED currents on/off as quickly as possible. For PWM low, the LT3909 turns off both LED current sources and regulates V_{OUT} to the last V_{OUT} level sampled during PWM high. This prevents V_{OUT} drooping during PWM low, due to Schottky diode reverse bias leakage or due to other leakage sources. By avoiding V_{OUT} droop during PWM low, much lower PWM on times are possible for the LED current sources and therefore much higher PWM dimming ratios. For low PWM on-time, V_{OUT} may regulate to the OVP level to guarantee the highest PWM dimming ratio.

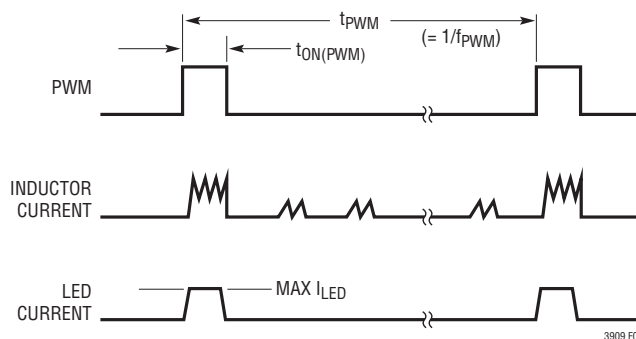

Figure 2. PWM Dimming Waveform

Some general guidelines for LED current dimming using the PWM pin (see Figure 2):

1. PWM Dimming Ratio (PDR) = $1 / (\text{PWM Duty Cycle}) = 1 / t_{ON(PWM)} \cdot f_{PWM}$
2. Lower PWM frequency (f_{PWM}) allows higher PWM dimming ratios (typically choose 100Hz to maximize PDR and to avoid visible flicker which can occur for display systems with refresh rates at frequencies below 80Hz).

APPLICATIONS INFORMATION

3. For the highest PWM dimming ratio, minimize LED string inductance (e.g. shorter LED wires) and capacitance on each LED pin. Higher LED current helps slew the LED pin faster, for a higher PWM dimming ratio.

4. Start-Up

The LT3909 V_{OUT} start-up requires the EN/UVLO and PWM pins to be asserted from off to on.

5. LED Fault Detection

Fault status is only updated during PWM high state and latched during PWM low. The lowest PWM on-time allowed for fault detection is $\approx 2.0\mu s$.

Programming LED Current Derating (Breakpoint and Slope) versus LED Ambient Temperature (CTRL Pin)

LED data sheets provide curves of maximum allowed LED current versus ambient temperature to warn against damaging of the LED (Figure 3). The LT3909 LED driver improves the utilization and reliability of the LED(s) by allowing the programming of an LED current derating curve versus the ambient temperature of the LED(s).

Without the ability to back off LED currents as temperature increases, many LED drivers are limited to driving the LED(s) at 50% or less of their maximum rated currents. This limitation requires more LEDs to obtain the intended brightness for the application. The LT3909 allows the LED(s) to be programmed for maximum allowable current while still protecting the LED(s) from excessive currents at high temperature. The temperature breakpoint and the slope of LED current versus ambient temperature can be programmed using a simple resistor network shown in Figure 4.

This is achieved by programming a voltage at the CTRL pin with a negative temperature coefficient using a resistor divider with temperature dependent resistance (Figure 4 and Figure 5). A variety of resistor networks and NTC resistors with different temperature coefficients can be used to achieve the desired CTRL pin voltage behavior versus temperature. The current derating curve in Figure 3 uses the resistor network shown in option A of Figure 4.

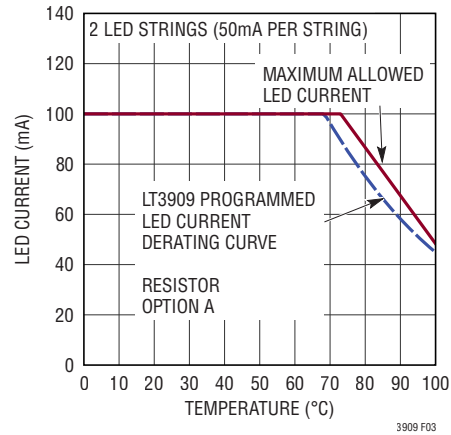

Figure 3. LED Current Derating vs LED Ambient Temperature

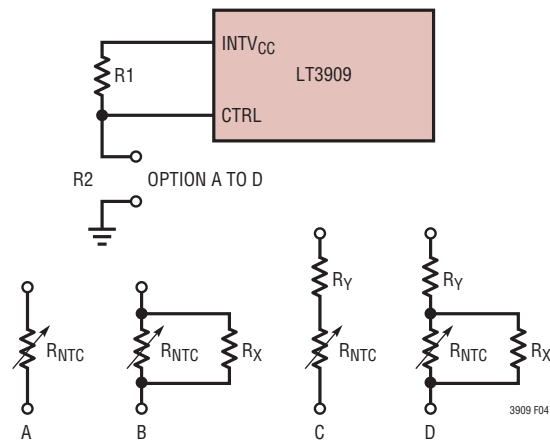

Figure 4. Programming LED Current Derating Curve vs LED Ambient Temperature (R_{NTC} Located Near LEDs on PCB)

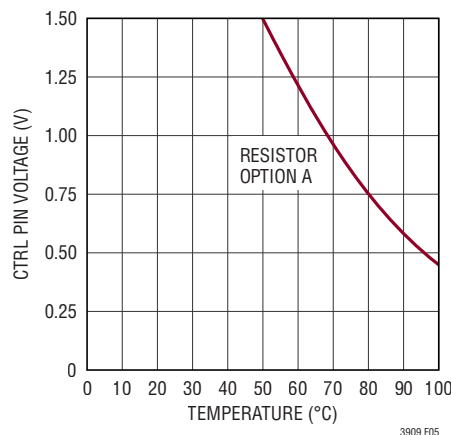

Figure 5. Programmed CTRL Voltage vs Temperature

APPLICATIONS INFORMATION

Table 4 shows a list of NTC resistor manufacturers/distributors. There are several other manufacturers available and the chosen supplier should be contacted for more detailed information. To use an NTC resistor to monitor the ambient temperature of the LED(s) it should be placed as close as possible to the LED(s). Since the temperature dependency of an NTC resistor can be nonlinear over a wide range of temperatures it is important to obtain a resistor's exact values over temperature from the manufacturer. Hand calculations of CTRL voltage can then be performed at each given temperature and the resulting CTRL voltage plotted versus temperature.

Table 4. NTC Resistor Manufacturers

MANUFACTURER	WEB
Murata Electronics North America	www.murata.com
TDK Corporation	www.tdk.com

If calculation of CTRL voltage at various temperatures gives a downward slope that is too strong, alternative resistor networks can be chosen (B, C, D in Figure 4) which use temperature independent resistance to reduce the effects of the NTC resistor over temperature. Murata Electronics provides a selection of NTC resistors with complete data over a wide range of temperatures. In addition, a software tool is available which allows the user to select from different resistor networks and NTC resistor values and then simulate the exact output voltage curve (CTRL pin behavior) over temperature. Referred to on the website as the Murata Chip NTC Thermistor Output Voltage Simulator, users can visit www.murata.com, click on the Design Tools tab and download the software followed by instructions for creating an output voltage V_{OUT} (LT3909 CTRL pin voltage) from a specified voltage supply. At any time during selection of circuit parameters the user can access data on the chosen NTC resistor by clicking on the link to the Murata catalog. For a detailed example of hand calculations using an NTC type resistor divider to program CTRL pin voltage, read the LT3478 LED driver data sheet section Programming LED Current Derating vs Temperature in the Applications Information section.

Inrush Current

The LT3909 has a built-in Schottky diode. When supply voltage is abruptly applied to the V_{IN} pin, with the output capacitor discharged, the voltage difference between V_{IN} and V_{OUT} generates inrush current flowing from the input through the inductor and the internal Schottky diode to charge the output capacitor C_{OUT} . The maximum current the LT3909 Schottky diode can sustain is 1.2A. Using a slower V_{IN} step and/or an inductor with larger DCR and/or a smaller output capacitor at the V_{OUT} pin will help minimize the inrush current.

LED Open and Short Circuit

The LT3909 monitors the voltage drop across each high-side current source and also each LED pin to determine if the LED string has an open-LED [$(V_{OUT} - V_{LEDx}) < 0.3V$] or LED-short-to-GND ($V_{LEDx} < 0.25 \cdot V_{OUT}$) fault. The \overline{FAULT} pin is pulled low if any of these faults are detected.

To avoid false detection of faults during the initial converter startup when V_{OUT} is low, the LT3909 disables the \overline{FAULT} pin until:

- 1) ~1.2ms after first PWM rising edge, and each current source has 1.3V (typical) across it (V_{OUT} correct and both strings connected) when both PWM is high for ~8 μ s and CTRL is > 80mV for ~4 μ s.
- 2) In the case of actual open-LED or LED-short-to-GND faults, V_{OUT} has reached 95% of its programmed OVP level.

Once either condition is met, the LT3909 enables the \overline{FAULT} flag and correctly reports LED-short-to-GND faults. Also at this time the switching frequency immediately steps up to 100% of full-scale.

It is important to note that even though the \overline{FAULT} pin is disabled during start-up, a true LED-short-to-GND fault will keep the LED current source off to protect that current source. The LT3909 correctly reports actual open-LED faults ~12ms after the very first PWM rising edge.

APPLICATIONS INFORMATION

To avoid errant faults during PWM dimming edges (where LED pins can possibly ring and trip fault detection levels), the LT3909 only monitors/updates fault conditions during PWM high (and only after a 1µs blanking following each PWM rising edge). Similarly, the LT3909 only monitors/updates fault conditions during CTRL higher than the latch-off threshold (and only after a 1µs blanking following the CTRL rising edge).

When an LED-short-to-GND fault is detected, the current source for that string is immediately turned off. If only one string has a fault, the LT3909 regulation loop will regulate V_{OUT} to the optimum level for the remaining valid string. If both strings have faults, the regulation loop will regulate V_{OUT} to the programmed OVP level.

Programming Maximum V_{OUT} (Regulated): Overvoltage Protection (OVP) Level

If the LED display faults open, V_{OUT} will rise. When the display is reconnected, the LEDs and their high-side current sources must be protected from excessively high V_{OUT} levels. To achieve this protection the LT3909 allows an overvoltage protection (OVP) level to be programmed for V_{OUT} . During an open display fault, V_{OUT} will be regulated to this OVP level. The OVP level must be programmed high enough to drive the largest expected LED string voltage and to allow at least 1.3V across each high-side current source. This ideal level would represent the largest V_{OUT} in regulation during a connected display, given by,

$$V_{OUT(REG)(MAX)} = 1.3V + N \cdot V_{F(MAX)}$$

N = the number of diodes in each string

$V_{F(MAX)}$ = the maximum expected forward voltage drop of the LEDs

As stated in the LED Open and Short Circuit section, the LT3909 during startup does not monitor the LED pins for open-LED faults until each LED current source has 1.3V across it or, in the case of an actual open-LED fault, until V_{OUT} has risen to 95% of its programmed OVP level. For this startup procedure to operate correctly, 95% of the programmed OVP level must be high enough to satisfy

the V_{OUT} regulation equation above. Hence OVP should be programmed to satisfy:

$$\begin{aligned} \text{Required } V_{OUT(OVP)} &= \frac{V_{OUT(REG)(MAX)}}{0.95} \\ &= (1.3V + N \cdot V_{F(MAX)}) / 0.95 \end{aligned}$$

OVP is programmed using a resistor divider from V_{OUT} to GND connected to the FB pin. The required OVP level should be calculated from the equation above. Once known, OVP resistors can be programmed by,

$$\text{Programmed } V_{OUT(OVP)} = 1.215V \cdot \left(1 + \frac{R_{FB2}}{R_{FB1}} \right)$$

Thermal Protection

The LT3909 contains a thermal regulation loop that limits the internal junction temperature of the part. Since the LT3909 topology consists of a single boost controller with two linear current sources, any LED string voltage mismatch will cause additional power to be dissipated in the package. This topology provides excellent current matching between LED strings and allows a single power stage to drive a large number of LEDs, but at the price of additional power dissipation inside the part (which means a higher junction temperature). Being able to limit the maximum junction temperature allows the benefits of this topology to be fully realized. This thermal regulation feature provides important protection at high ambient temperatures, with the assurance that the LT3909 will automatically protect itself and the LED strings.

The operation of the thermal loop is simple. As the ambient temperature increases, so does the internal junction temperature of the part. Once the junction temperature reaches approximately 160°C, the LT3909 begins to linearly reduce the LED current, to maintain the junction temperature at around 160°C. If the junction temperature continues to rise past 160°C, LED current will be reduced to approximately 5% of full LED current. The LT3909 stops switching when thermal shutdown is actuated (approximately 170°C).

APPLICATIONS INFORMATION

Thermal Considerations

For higher ambient temperatures, care should be taken in the layout of the PCB to ensure good heat sinking of the LT3909. The exposed pad on the bottom of the package must be soldered to a ground plane. This ground should be tied to large copper layers below with thermal vias; these layers will spread heat dissipated by the LT3909. Placing additional vias can reduce thermal resistance further. Power dissipation within the LT3909 can be estimated by calculating the total power loss from an efficiency measurement and subtracting the inductor loss. The die temperature is calculated by multiplying the LT3909 power dissipation by the thermal resistance of the package (see the Pin Configuration). See the Thermal Protection section.

Circuit Layout Considerations

As with all switching regulators, careful attention must be given to PCB layout and component placement to achieve optimal thermal, electrical and noise performance. The exposed pad of the LT3909 is the only ground connection for the IC. The exposed pad should be soldered to a continu-

ous copper ground plane underneath the device to reduce die temperature and maximize the power capability of the IC. An analog ground is connected to the exposed pad near the CTRL and FB pins. I_{SET} , CTRL and FB components should be connected to an area of ground copper near these pins. The internal power switch current escapes through the exposed pad near the SW pin. This area of copper should be the power ground (PGND) connection for the inductor input capacitor, $INTV_{CC}$ capacitor and output capacitor. A separate bypass capacitor for the V_{IN} pin of the IC may be required close to the V_{IN} pin and connected to the copper area associated with analog ground. To reduce the effects of both radiated and conducted noise, the length and area of the copper trace for the SW pin should be kept as small as possible. Use a ground plane under the switching regulator to minimize interplane coupling. The optional Schottky diode and output capacitor should be placed as close as possible to the SW pin to minimize this high switching frequency path. To achieve the best PWM dimming ratio, minimize the trace capacitance on each LED pin.

TYPICAL APPLICATIONS

2-String × 20mA Driver for Five White LEDs/String

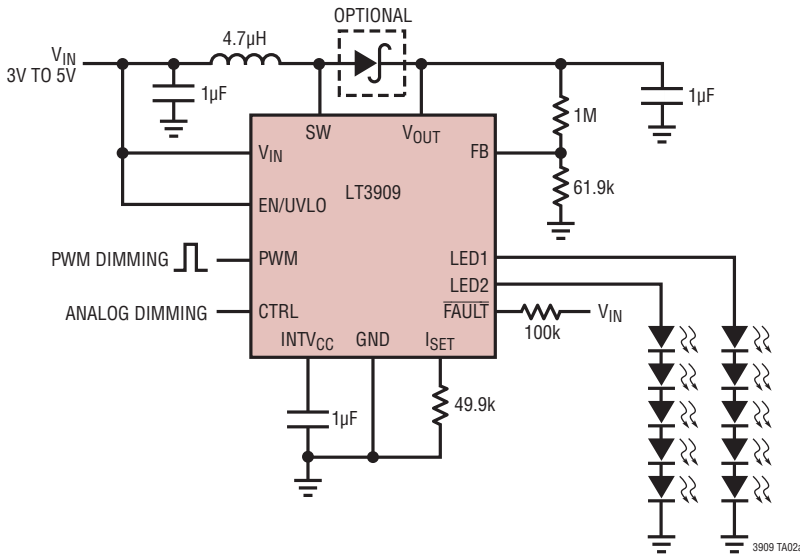

LED Current Matching (Normalized to 2-String Average)

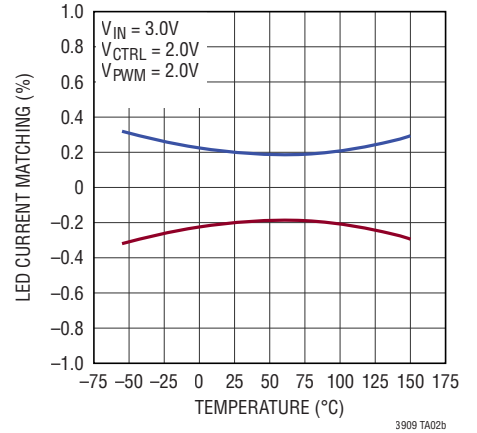

2-String × 50mA Driver for Five White LEDs/String

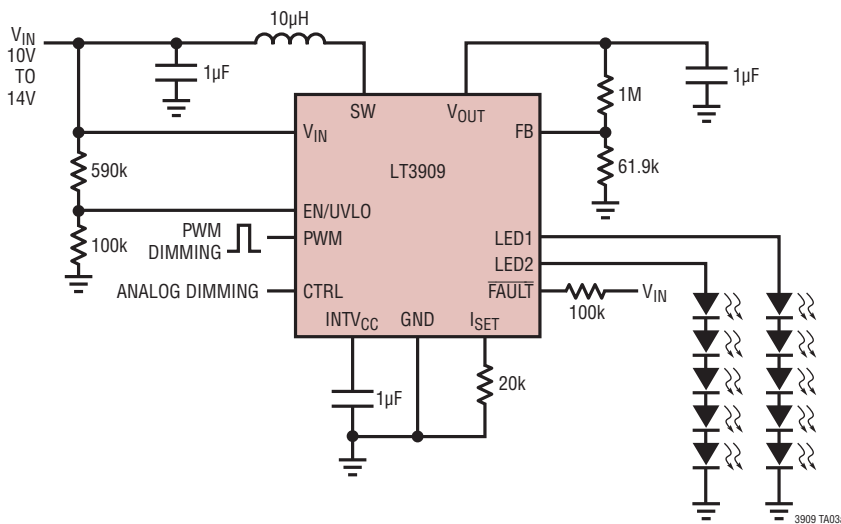

LED Current Waveforms 20,000:1 PWM Dimming (100Hz)

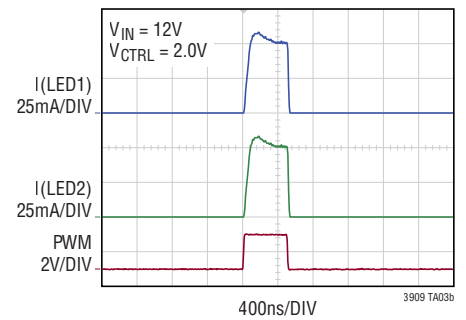

TYPICAL APPLICATIONS

2-String × 60mA Driver for Six White LEDs/String

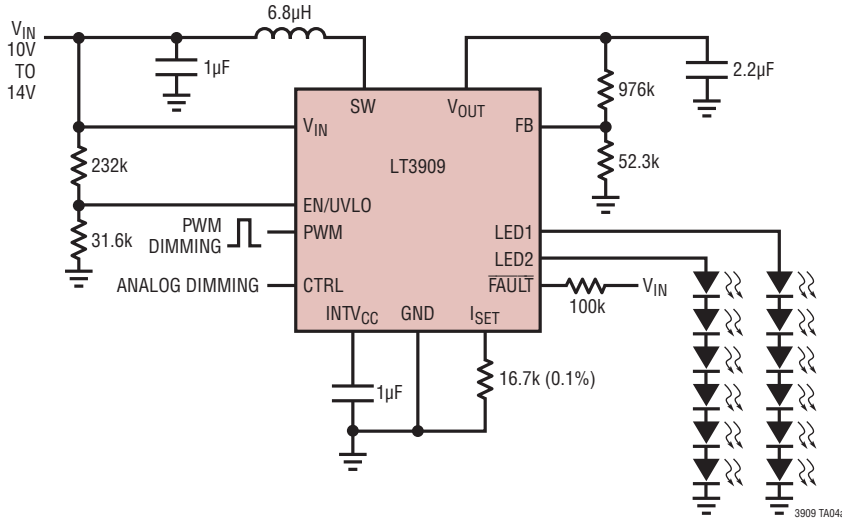

LED Current Waveforms
20,000:1 PWM Dimming (100Hz)

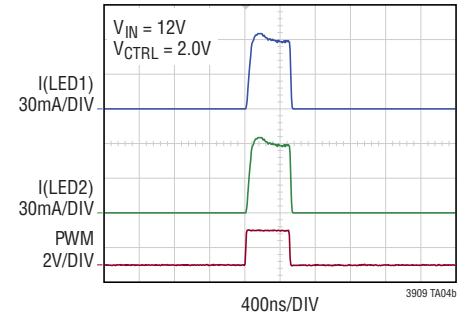

1 String × 100mA Driver for Ten White LEDs

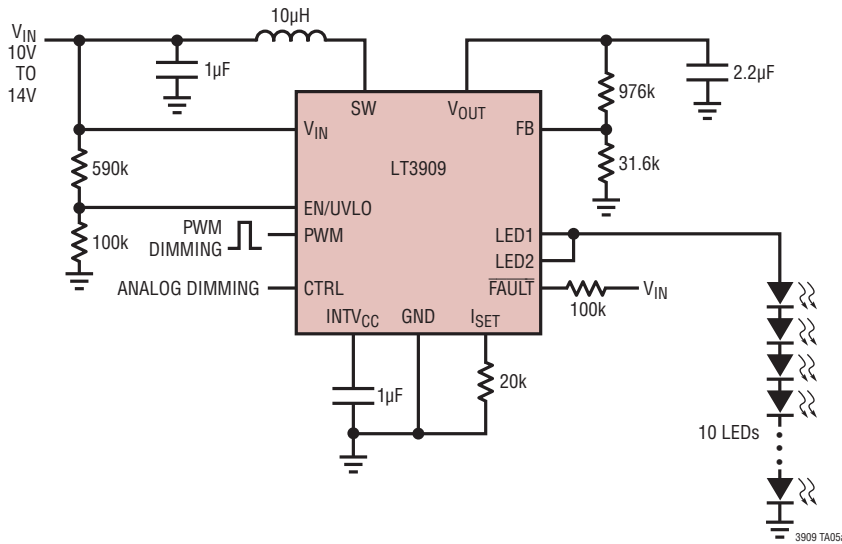

LED Current Waveforms
20,000:1 PWM Dimming (100Hz)

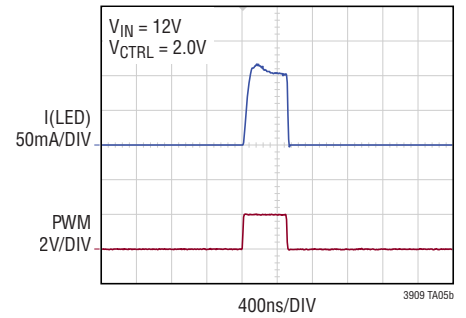

TYPICAL APPLICATIONS

2-String × 40mA Buck-Boost Mode Driver for Five White LEDs/String

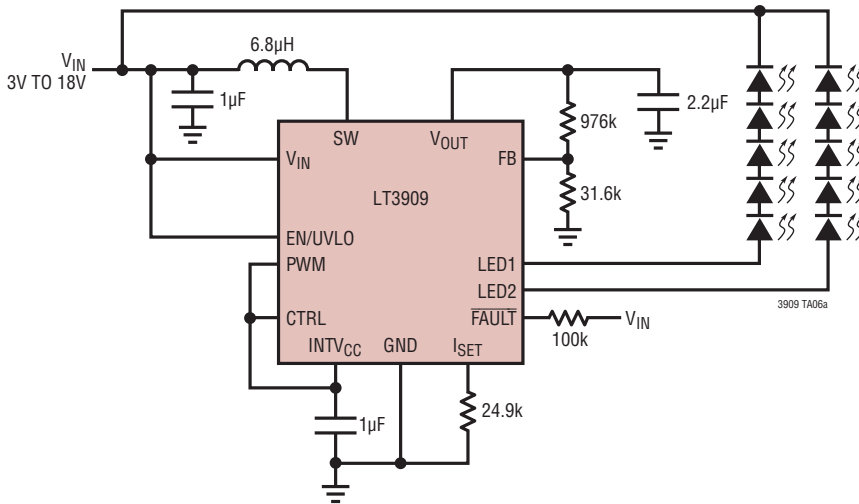

V_{IN} Transient Response

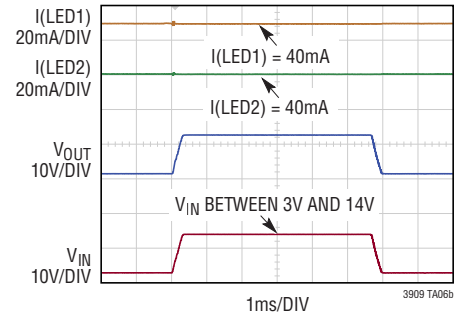

Protection in High V_{IN} Event

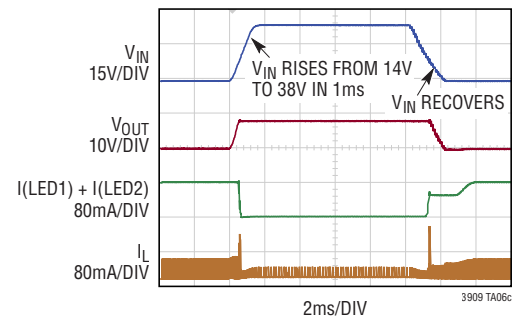

PACKAGE DESCRIPTION

Please refer to <http://www.linear.com/product/LT3909#packaging> for the most recent package drawings.

DD Package
12-Lead Plastic DFN (3mm × 3mm)
 (Reference LTC DWG # 05-08-1725 Rev A)

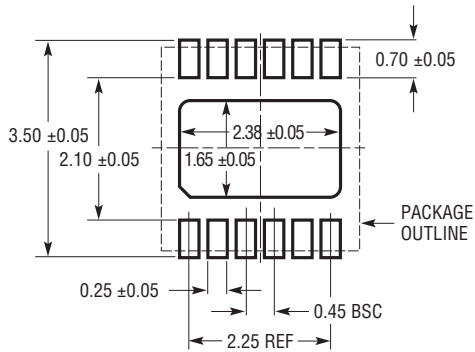

RECOMMENDED SOLDER PAD PITCH AND DIMENSIONS
 APPLY SOLDER MASK TO AREAS THAT ARE NOT SOLDERED

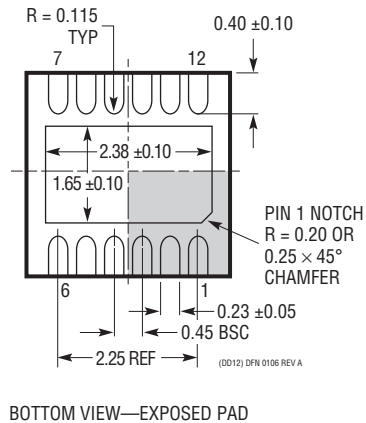
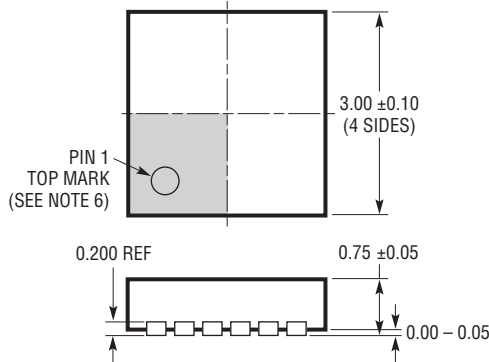

- NOTE:
1. DRAWING IS NOT A JEDEC PACKAGE OUTLINE
 2. DRAWING NOT TO SCALE
 3. ALL DIMENSIONS ARE IN MILLIMETERS
 4. DIMENSIONS OF EXPOSED PAD ON BOTTOM OF PACKAGE DO NOT INCLUDE MOLD FLASH. MOLD FLASH, IF PRESENT, SHALL NOT EXCEED 0.15mm ON ANY SIDE
 5. EXPOSED PAD AND TIE BARS SHALL BE SOLDER PLATED
 6. SHADED AREA IS ONLY A REFERENCE FOR PIN 1 LOCATION ON THE TOP AND BOTTOM OF PACKAGE

PACKAGE DESCRIPTION

Please refer to <http://www.linear.com/product/LT3909#packaging> for the most recent package drawings.

MSE Package 12-Lead Plastic MSOP, Exposed Die Pad (Reference LTC DWG # 05-08-1666 Rev G)

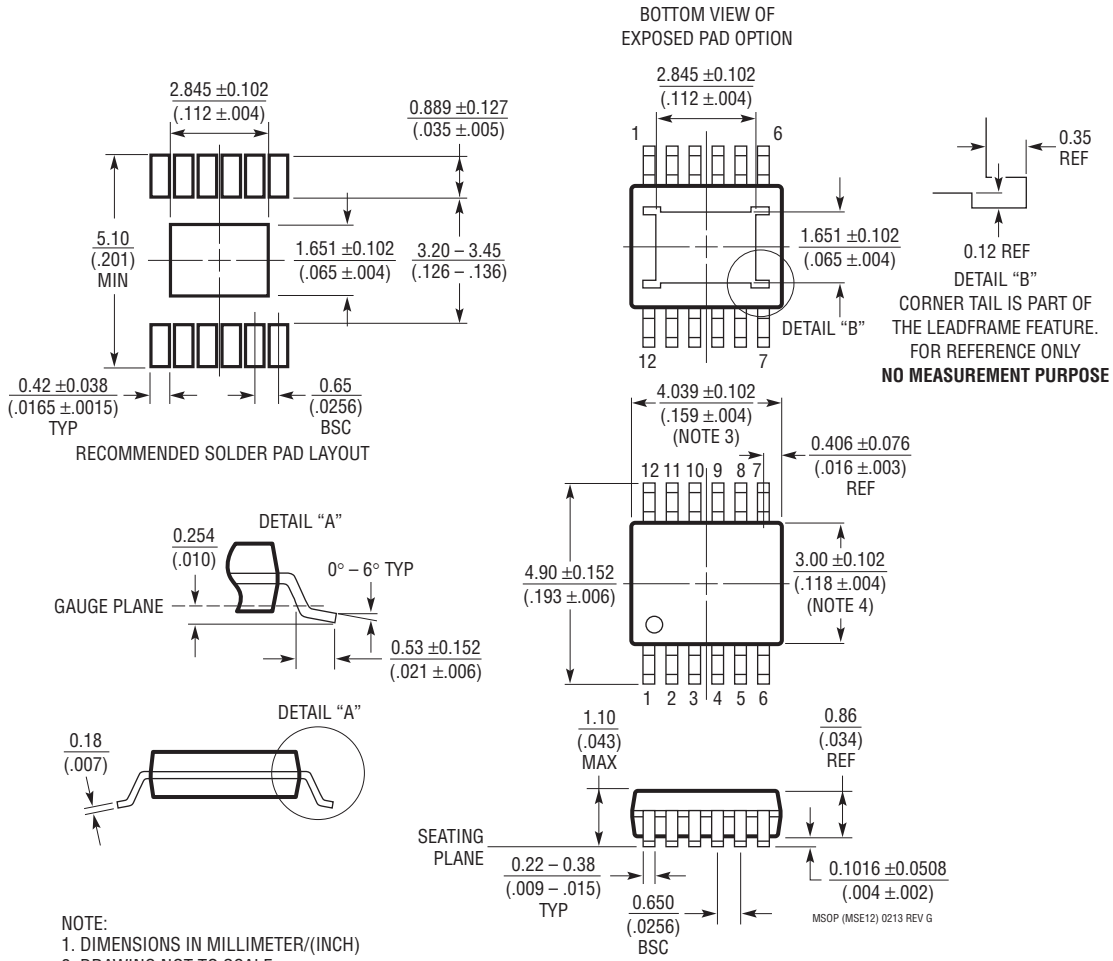

- NOTE:
1. DIMENSIONS IN MILLIMETER/(INCH)
 2. DRAWING NOT TO SCALE
 3. DIMENSION DOES NOT INCLUDE MOLD FLASH, PROTRUSIONS OR GATE BURRS. MOLD FLASH, PROTRUSIONS OR GATE BURRS SHALL NOT EXCEED 0.152mm (.006") PER SIDE
 4. DIMENSION DOES NOT INCLUDE INTERLEAD FLASH OR PROTRUSIONS. INTERLEAD FLASH OR PROTRUSIONS SHALL NOT EXCEED 0.152mm (.006") PER SIDE
 5. LEAD COPLANARITY (BOTTOM OF LEADS AFTER FORMING) SHALL BE 0.102mm (.004") MAX
 6. EXPOSED PAD DIMENSION DOES INCLUDE MOLD FLASH. MOLD FLASH ON E-PAD SHALL NOT EXCEED 0.254mm (.010") PER SIDE.

REVISION HISTORY

REV	DATE	DESCRIPTION	PAGE NUMBER
A	04/16	Clarified Title, Description and Features	1
		Clarified Absolute Maximum Ratings	2
		Removed H-Grade Parts from Order Information	2
		Clarified Electrical Specifications	3
		Clarified Notes	4
		Clarified Graphs	6
		Clarified LED Current Waveforms Graph	7
		Clarified Pin Functions	8
		Clarified Block Diagram	9
		Clarified LED Current Modulation/Regulation and Boost Converter Sections	10
		Clarified Table 3	13
		Clarified LED Open and Short Circuit Section	15
		Clarified Programming Maximum V_{OUT} Section	16
Clarified Applications Schematics	18, 19, 22		
B	08/16	Revised graph G13	6
		Revised I_{SET} resistance tolerance	13, 19

TYPICAL APPLICATION

2-String × 20mA, 2MHz LED Driver for Ten White LEDs/String

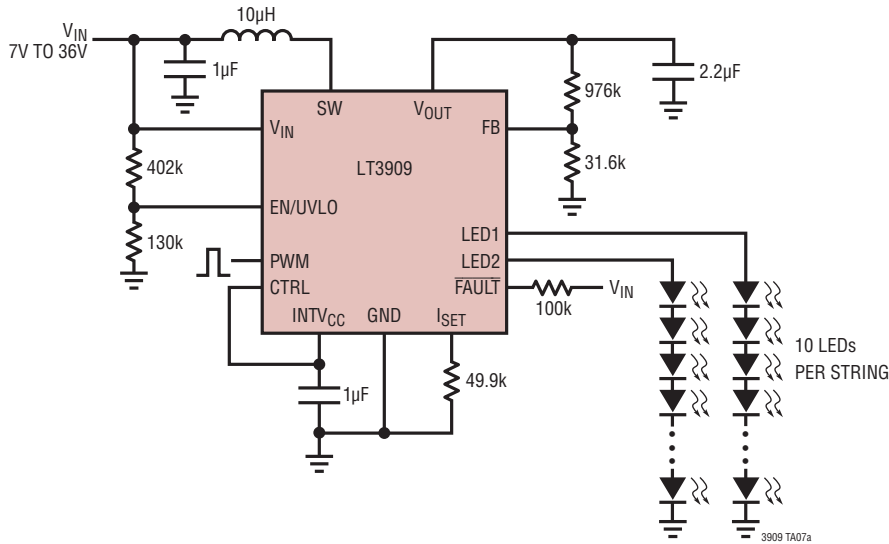

LED Current Matching (Normalized to 2-String Average)

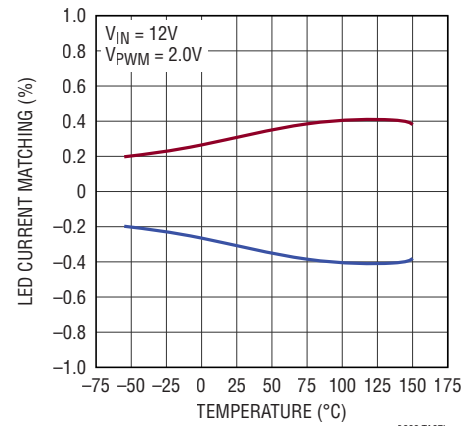

RELATED PARTS

PART NUMBER	DESCRIPTION	COMMENTS
LT3476	Quad Output 1.5A, 2MHz High Current LED Driver with 5,000:1 Dimming	V _{IN(MIN)} = 2.8V, V _{IN(MAX)} = 16V, V _{OUT(MAX)} = 36V, 5,000:1 True Color PWM Dimming, I _{SD} < 10µA, 5mm × 7mm QFN-38
LT3496	Triple Output 750mA, 2.1MHz High Current LED Driver with 3,000:1 Dimming	V _{IN(MIN)} = 3.0V, V _{IN(MAX)} = 30V, V _{OUT(MAX)} = 40V, 3,000:1 True Color PWM Dimming, I _{SD} < 1µA, 4mm × 5mm QFN-28, TSSOP-28E
LT3591	Constant Current, 1MHz, White LED Boost Regulator with Integrated Schottky Diode	V _{IN(MIN)} = 2.5V, V _{IN(MAX)} = 12V, V _{OUT(MAX)} = 40V, I _Q = 4mA, 80:1 True Color PWM Dimming, I _{SD} < 11µA, 2mm × 3mm DFN-8
LT3595A	45V, 2MHz Buck 16-Channel 50mA LED Driver	V _{IN(MIN)} = 4.5V, V _{IN(MAX)} = 45V, V _{OUT(MAX)} = 45V, 5,000:1 True Color PWM Dimming, I _{SD} < 40µA, 5mm × 9mm QFN-56
LT3598	44V, 1.5A, 2.5MHz Boost 6-String 20mA LED Driver	V _{IN(MIN)} = 3.2V, V _{IN(MAX)} = 30V, V _{OUT(MAX)} = 44V, 3,000:1 True Color PWM Dimming, I _{SD} < 1µA, 4mm × 4mm QFN-24, TSSOP-24E
LT3599	44V, 2A, 2.1MHz Boost 4-String 120mA LED Driver	V _{IN(MIN)} = 3.1V, V _{IN(MAX)} = 30V, V _{OUT(MAX)} = 44V, 3,000:1 True Color PWM Dimming, I _{SD} < 1µA, 5mm × 5mm QFN-32, TSSOP-28E
LT3745	16-String 50mA LED Driver with Buck Controller	V _{IN(MIN)} = 6.0V, V _{IN(MAX)} = 55V, V _{OUT(MAX)} = 36V, 0.5µs Minimum PWM Dimming On-Time, I _{SD} < 2µA, 6mm × 6mm QFN-40
LT3754	16-String × 50mA LED Driver	V _{IN(MIN)} = 6.0V, V _{IN(MAX)} = 40V, V _{OUT(MAX)} = 45V, 3,000:1 True Color PWM Dimming, I _{SD} < 10µA, 5mm × 5mm QFN-32
LT3760	8-String × 100mA LED Driver	V _{IN(MIN)} = 6.0V, V _{IN(MAX)} = 40V, V _{OUT(MAX)} = 45V, 3,000:1 True Color PWM Dimming, I _{SD} < 10µA, TSSOP-28E

Looking for pricing, stock, or lifecycle information?

Click below to explore more details on WIN SOURCE:

 [View LT3909EMSE#PBF on WIN SOURCE](#)

 [Linear Technology](#) Information

Optimize Your Supply Chain with WIN SOURCE Solutions

-  Global Sourcing Solution
-  Obsolete Management
-  Cost Control Management
-  Shortage Management
-  Alternative Solution
-  Excess Inventory Management