



**THE DATASHEET OF
LT3970EDDB-3.3#TRPBF**



40V, 350mA Step-Down Regulator with 2.5 μ A Quiescent Current and Integrated Diodes

FEATURES

- **Low Ripple Burst Mode[®] Operation**
 2.5 μ A I_Q at 12V_{IN} to 3.3V_{OUT}
 Output Ripple < 5mV_{p-p}
- **Wide Input Voltage Range: 4.2V to 40V Operating**
- **Adjustable Switching Frequency: 200kHz to 2.2MHz**
- **Integrated Boost and Catch Diodes**
- **350mA Output Current**
- **Fixed Output Voltages: 3.3V, 3.42V, 5V**
 1.8 μ A I_Q at 12V_{IN}
- Accurate 1V Enable Pin Threshold
- Low Shutdown Current: $I_Q = 0.7\mu$ A
- Internal Sense Limits Catch Diode Current
- Power Good Flag
- Output Voltage: 1.21V to 25V
- Internal Compensation
- Small 10-Pin MSOP and (3mm \times 2mm) DFN Packages

APPLICATIONS

- Automotive Battery Regulation
- Power for Portable Products
- Industrial Supplies

DESCRIPTION

The LT[®]3970 is an adjustable frequency monolithic buck switching regulator that accepts a wide input voltage range up to 40V, and consumes only 2.5 μ A of quiescent current. A high efficiency switch is included on the die along with the catch diode, boost diode, and the necessary oscillator, control and logic circuitry. Low ripple Burst Mode operation maintains high efficiency at low output currents while keeping the output ripple below 5mV in a typical application. Current mode topology is used for fast transient response and good loop stability. A catch diode current limit provides protection against shorted outputs and overvoltage conditions. An enable pin with accurate threshold is available, producing a low shutdown current of 0.7 μ A. A power good flag signals when V_{OUT} reaches 90% of the programmed output voltage. The LT3970 is available in small 10-pin MSOP and 3mm \times 2mm DFN packages.

LT, LT, LTC, LTM, Burst Mode, Linear Technology and the Linear logo are registered trademarks of Linear Technology Corporation. All other trademarks are the property of their respective owners.

TYPICAL APPLICATION

5V Step-Down Converter

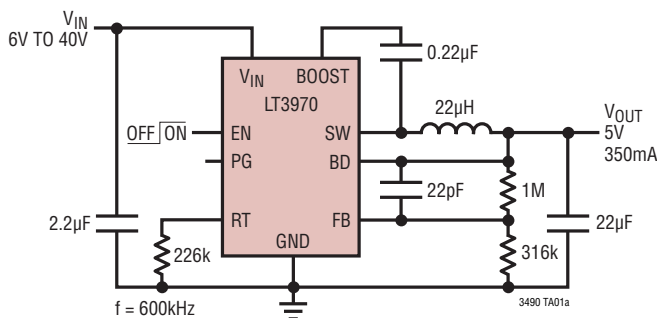

Efficiency

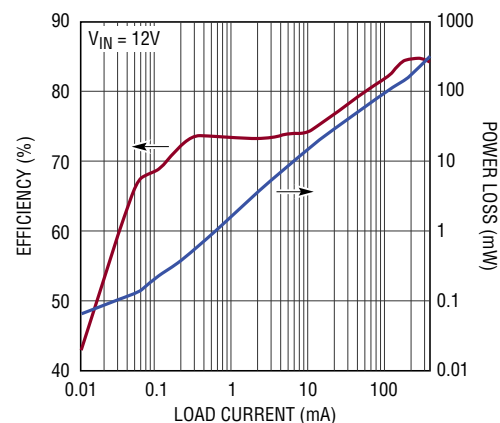

3970 TA01b

3970fc

LT3970 Series

ABSOLUTE MAXIMUM RATINGS (Note 1)

V_{IN} , EN Voltage	40V	Operating Junction Temperature Range (Note 2)	
BOOST Pin Voltage	55V	E-, I-grade.....	-40°C to 125°C
BOOST Pin Above SW Pin.....	30V	H-grade.....	-40°C to 150°C
FB/ V_{OUT} , RT Voltage.....	6V	Storage Temperature Range.....	-65°C to 150°C
PG, BD Voltage	30V	Lead Temperature (Soldering, 10 sec)	
		MS Only	300°C

PIN CONFIGURATION

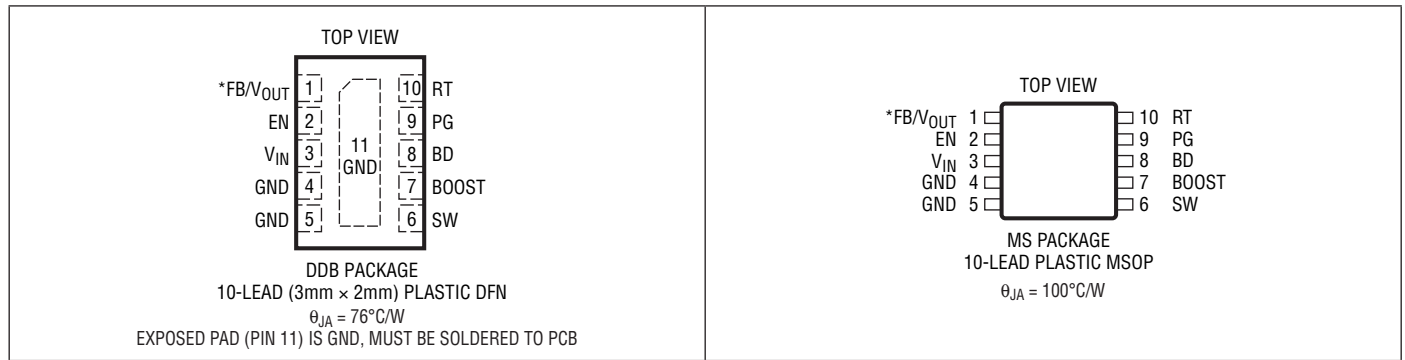

*FB for LT3970, V_{OUT} for LT3970-3.3, LT3970-3.42, LT3970-5.

ORDER INFORMATION

LEAD FREE FINISH	TAPE AND REEL	PART MARKING*	PACKAGE DESCRIPTION	TEMPERATURE RANGE
LT3970EDDB#PBF	LT3970EDDB#TRPBF	LFCZ	10-Lead (3mm × 2mm) Plastic DFN	-40°C to 125°C
LT3970IDDB#PBF	LT3970IDDB#TRPBF	LFCZ	10-Lead (3mm × 2mm) Plastic DFN	-40°C to 125°C
LT3970EMS#PBF	LT3970EMS#TRPBF	LTFDB	10-Lead Plastic MSOP	-40°C to 125°C
LT3970IMS#PBF	LT3970IMS#TRPBF	LTFDB	10-Lead Plastic MSOP	-40°C to 125°C
LT3970HMS#PBF	LT3970HMS#TRPBF	LTFDB	10-Lead Plastic MSOP	-40°C to 150°C
LT3970EDDB-3.3#PBF	LT3970EDDB-3.3#TRPBF	LFQH	10-Lead (3mm × 2mm) Plastic DFN	-40°C to 125°C
LT3970IDDB-3.3#PBF	LT3970IDDB-3.3#TRPBF	LFQH	10-Lead (3mm × 2mm) Plastic DFN	-40°C to 125°C
LT3970EMS-3.3#PBF	LT3970EMS-3.3#TRPBF	LTFQG	10-Lead Plastic MSOP	-40°C to 125°C
LT3970IMS-3.3#PBF	LT3970IMS-3.3#TRPBF	LTFQG	10-Lead Plastic MSOP	-40°C to 125°C
LT3970HMS-3.3#PBF	LT3970HMS-3.3#TRPBF	LTFQG	10-Lead Plastic MSOP	-40°C to 150°C
LT3970EDDB-3.42#PBF	LT3970EDDB-3.42#TRPBF	LGGG	10-Lead (3mm × 2mm) Plastic DFN	-40°C to 125°C
LT3970EDDB-5#PBF	LT3970EDDB-5#TRPBF	LFQF	10-Lead (3mm × 2mm) Plastic DFN	-40°C to 125°C
LT3970IDDB-5#PBF	LT3970IDDB-5#TRPBF	LFQF	10-Lead (3mm × 2mm) Plastic DFN	-40°C to 125°C
LT3970EMS-5#PBF	LT3970EMS-5#TRPBF	LTFQD	10-Lead Plastic MSOP	-40°C to 125°C
LT3970IMS-5#PBF	LT3970IMS-5#TRPBF	LTFQD	10-Lead Plastic MSOP	-40°C to 125°C
LT3970HMS-5#PBF	LT3970HMS-5#TRPBF	LTFQD	10-Lead Plastic MSOP	-40°C to 150°C

Consult LTC Marketing for parts specified with wider operating temperature ranges. *The temperature grade is identified by a label on the shipping container. Consult LTC Marketing for information on non-standard lead based finish parts.

For more information on lead free part marking, go to: <http://www.linear.com/leadfree/>

For more information on tape and reel specifications, go to: <http://www.linear.com/tapeandreeel/>

ELECTRICAL CHARACTERISTICS

The ● denotes the specifications which apply over the full operating temperature range, otherwise specifications are at $T_A = 25^\circ\text{C}$. $V_{IN} = 12\text{V}$, $V_{BD} = 3.3\text{V}$ unless otherwise noted. (Note 2)

PARAMETER	CONDITIONS		MIN	TYP	MAX	UNITS
Minimum Input Voltage		●		4	4.2	V
Quiescent Current from V_{IN}	V_{EN} Low			0.7	1.2	μA
	V_{EN} High			1.7	2.7	μA
	V_{EN} High, -40°C to 125°C	●			3.5	μA
	V_{EN} High, -40°C to 150°C	●			4	μA
LT3970 Feedback Voltage	-40°C to 125°C	●	1.195	1.21	1.225	V
	-40°C to 150°C	●	1.185	1.21	1.235	V
		●	1.18	1.21	1.235	V
LT3970-3.3 Output Voltage	-40°C to 125°C	●	3.26	3.3	3.34	V
	-40°C to 150°C	●	3.234	3.3	3.366	V
		●	3.217	3.3	3.366	V
LT3970-3.42 Output Voltage	-40°C to 125°C	●	3.379	3.42	3.461	V
		●	3.352	3.42	3.488	V
LT3970-5 Output Voltage	-40°C to 125°C	●	4.94	5	5.06	V
	-40°C to 150°C	●	4.9	5	5.1	V
		●	4.875	5	5.1	V
LT3970 FB Pin Bias Current (Note 3)	$V_{FB} = 1.21\text{V}$	●		0.1	20	nA
FB/Output Voltage Line Regulation	$4.2\text{V} < V_{IN} < 40\text{V}$			0.0002	0.01	%/V
Switching Frequency	$R_T = 41.2\text{k}$, $V_{IN} = 6\text{V}$		1.76	2.25	2.64	MHz
	$R_T = 158\text{k}$, $V_{IN} = 6\text{V}$		640	800	960	kHz
	$R_T = 768\text{k}$, $V_{IN} = 6\text{V}$		160	200	240	kHz
Switch Current Limit	$V_{IN} = 5\text{V}$, $V_{FB} = 0\text{V}$		535	700	865	mA
Catch Schottky Current Limit	$V_{IN} = 5\text{V}$		350	400	500	mA
Switch V_{CESAT}	$I_{SW} = 200\text{mA}$			175		mV
Switch Leakage Current				0.05	2	μA
Catch Schottky Forward Voltage	$I_{SCH} = 100\text{mA}$, $V_{IN} = V_{BD} = \text{NC}$			650		mV
Catch Schottky Reverse Leakage	$V_{SW} = 12\text{V}$			0.05	2	μA
Boost Schottky Forward Voltage	$I_{SCH} = 50\text{mA}$, $V_{IN} = \text{NC}$, $V_{BOOST} = 0\text{V}$			875		mV
Boost Schottky Reverse Leakage	$V_{REVERSE} = 12\text{V}$			0.02	2	μA
Minimum Boost Voltage (Note 4)	$V_{IN} = 5\text{V}$	●		1.4	1.8	V
BOOST Pin Current	$I_{SW} = 200\text{mA}$, $V_{BOOST} = 15\text{V}$			7	10	mA
EN Pin Current	$V_{EN} = 12\text{V}$			1	30	nA
LT3970 EN Voltage Threshold	EN Rising, $V_{IN} \geq 4.2\text{V}$	●	0.94	1	1.06	V
LT3970-X EN Voltage Threshold	EN Rising, $V_{IN} \geq 4.2\text{V}$	●	0.93	1	1.07	V
EN Voltage Hysteresis				30		mV
LT3970 PG Threshold Offset from Feedback Voltage	V_{FB} Rising		80	120	160	mV
LT3970 PG Hysteresis				12		mV
LT3970-X PG Threshold Offset from Output Voltage	V_{FB} Rising		6.5	10	13.5	%
LT3970-X PG Hysteresis as % of Output Voltage				1.0		%
PG Leakage	$V_{PG} = 3\text{V}$			0.01	1	μA
PG Sink Current	$V_{PG} = 0.4\text{V}$	●	30	80		μA
Minimum Switch On-Time				90		ns
Minimum Switch Off-Time	$V_{IN} = 10\text{V}$	●		100	160	ns

ELECTRICAL CHARACTERISTICS

Note 1: Stresses beyond those listed under Absolute Maximum Ratings may cause permanent damage to the device. Exposure to any Absolute Maximum Rating condition for extended periods may affect device reliability and lifetime.

Note 2: The LT3970E is guaranteed to meet performance specifications from 0°C to 125°C junction temperature. Specifications over the -40°C to 125°C operating junction temperature range are assured by design, characterization, and correlation with statistical process controls. The

LT3970I is guaranteed over the full -40°C to 125°C operating junction temperature range. The LT3970H is guaranteed over the full -40°C to 150°C operating junction temperature range. High junction temperatures degrade operating lifetimes. Operating lifetime is derated at junction temperatures greater than 125°C.

Note 3: Bias current flows into the FB pin.

Note 4: This is the minimum voltage across the boost capacitor needed to guarantee full saturation of the switch.

TYPICAL PERFORMANCE CHARACTERISTICS $T_A = 25^\circ\text{C}$, unless otherwise noted.

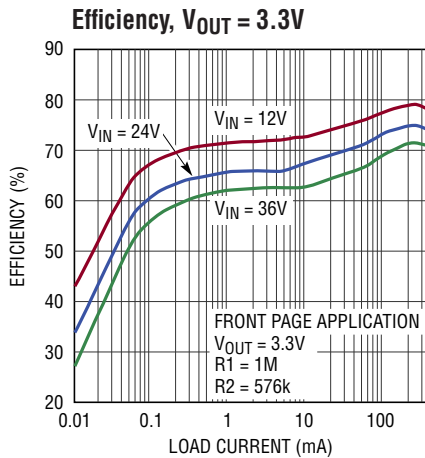

3970 G01

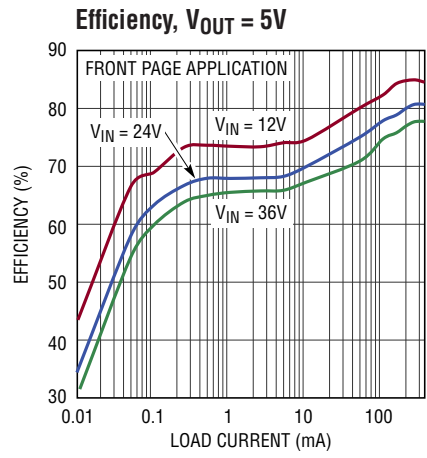

3970 G02

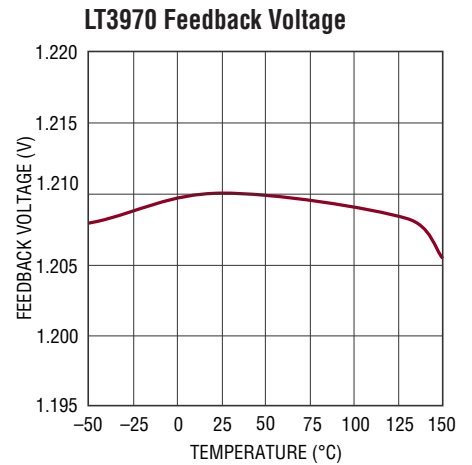

3970 G03

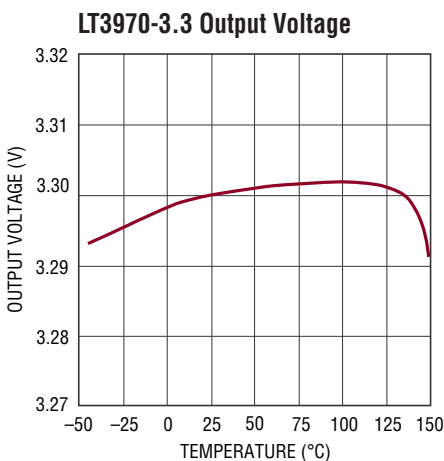

3970 G04

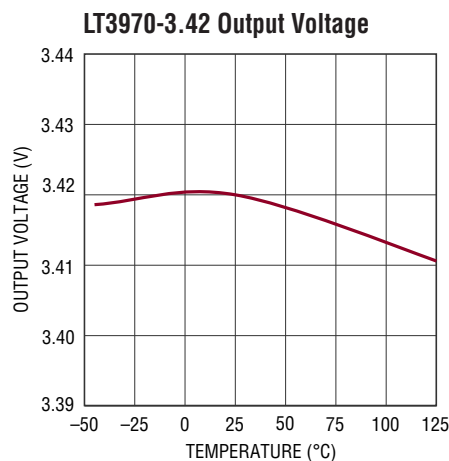

3970 G05

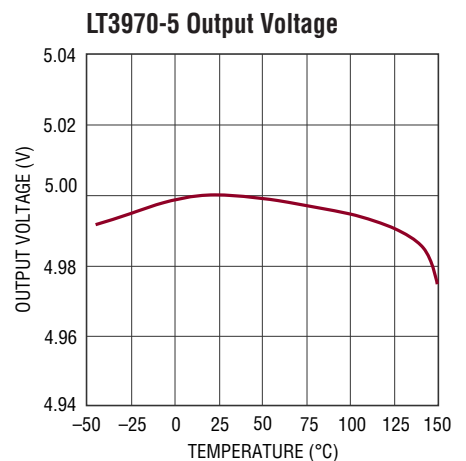

3970 G06

TYPICAL PERFORMANCE CHARACTERISTICS $T_A = 25^\circ\text{C}$, unless otherwise noted.

No-Load Supply Current

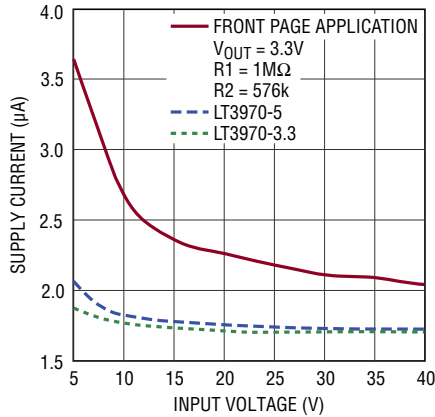

3970 G07

No-Load Supply Current

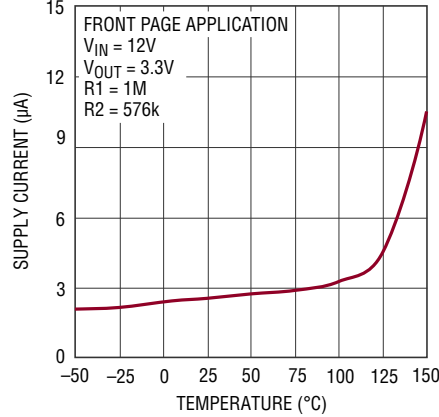

3970 G08

Maximum Load Current

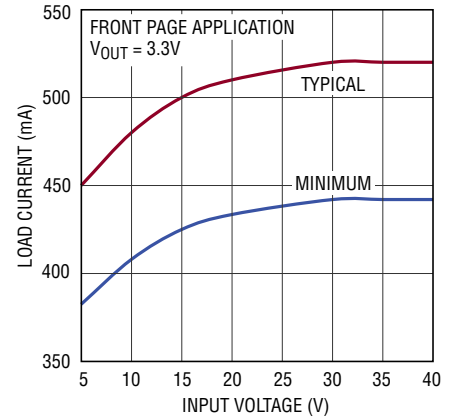

3870 G09

Maximum Load Current

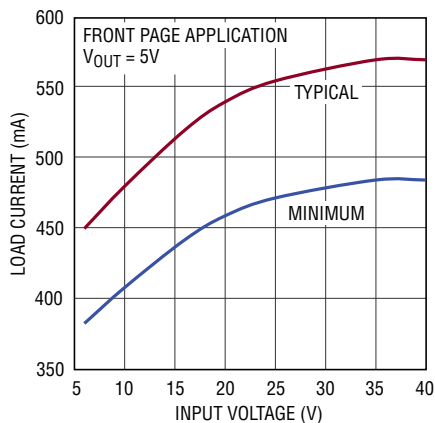

3870 G10

Maximum Load Current

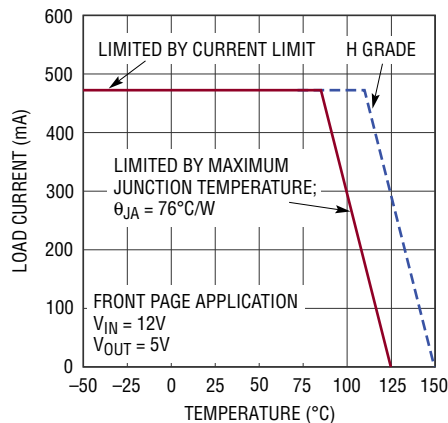

3970 G11

Load Regulation

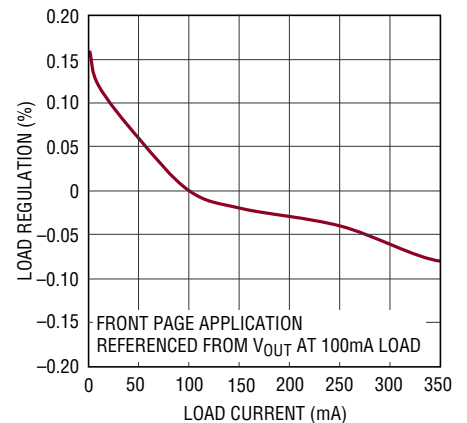

3970 G12

Switch Current Limit

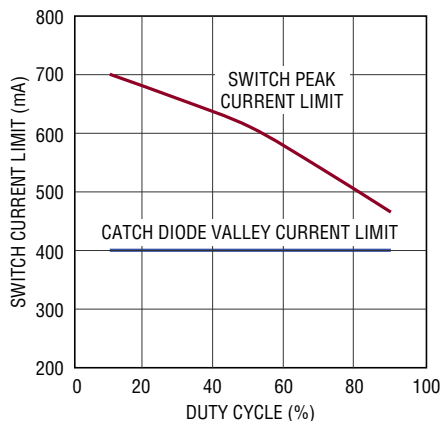

3970 G13

Switch Current Limit

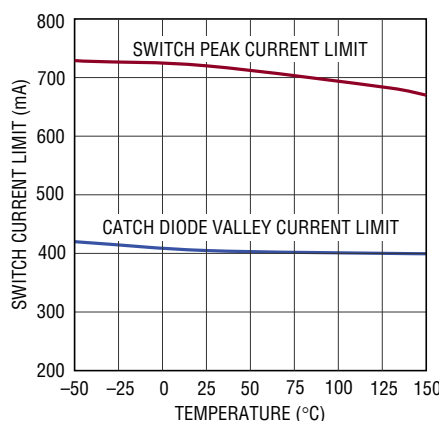

3970 G14

Switching Frequency

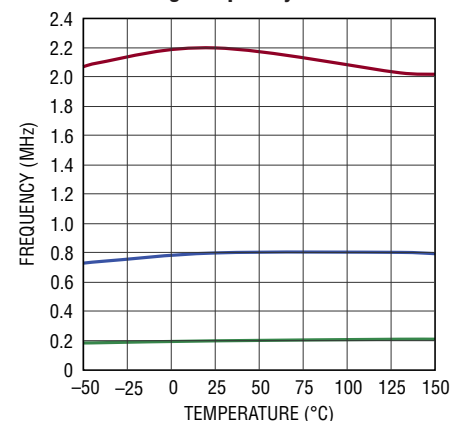

3970 G15

TYPICAL PERFORMANCE CHARACTERISTICS $T_A = 25^\circ\text{C}$, unless otherwise noted.

Minimum Switch On-Time/Switch Off-Time

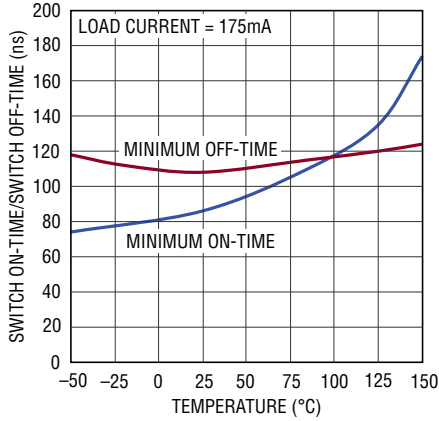

3970 G16

Switch V_{CESAT} ($I_{SW} = 200\text{mA}$) vs Temperature

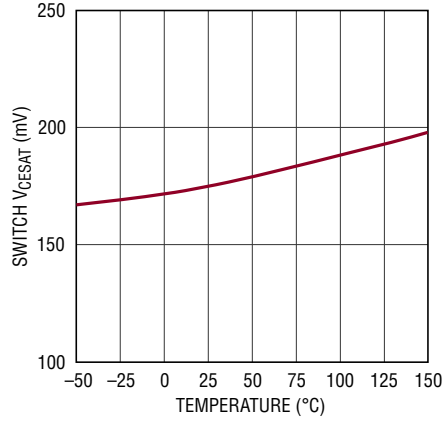

3970 G17

Switch V_{CESAT}

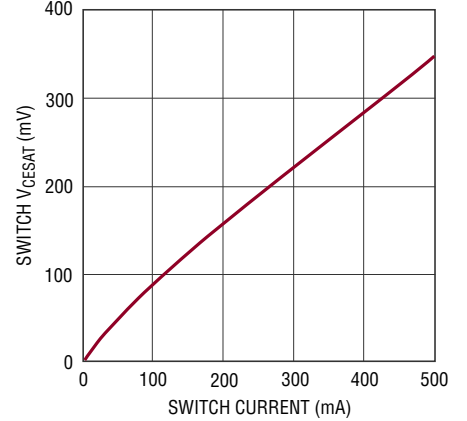

3970 G18

BOOST Pin Current

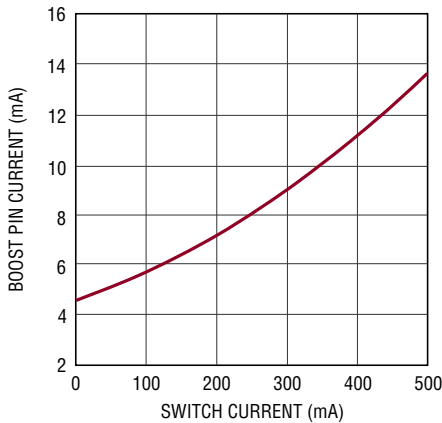

3970 G19

Minimum Input Voltage, $V_{OUT} = 3.3\text{V}$

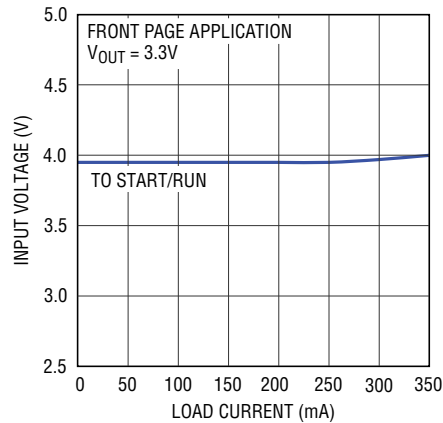

3970 G20

Minimum Input Voltage, $V_{OUT} = 5\text{V}$

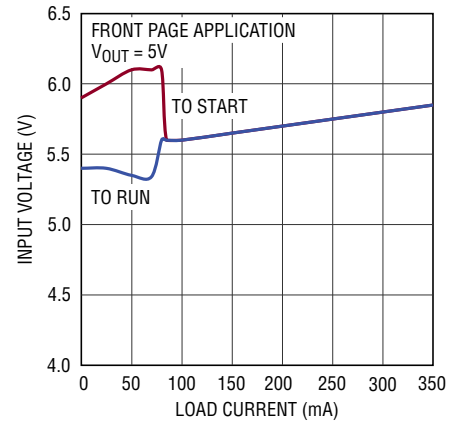

3970 G21

Boost Diode Forward Voltage

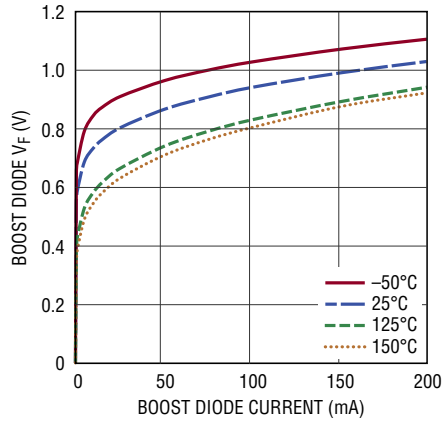

3970 G22

Catch Diode Forward Voltage

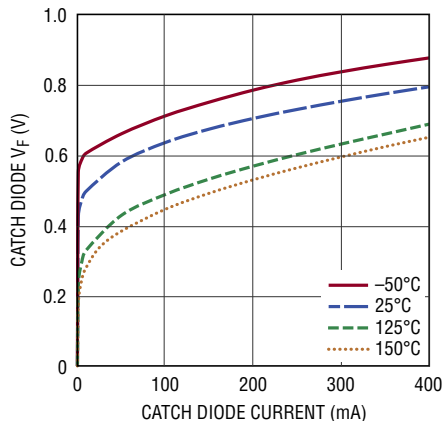

3970 G23

Catch Diode Leakage

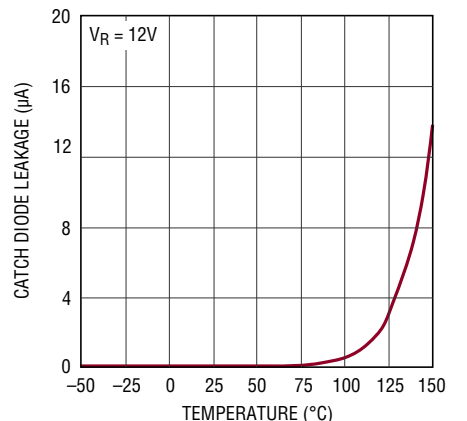

3970 G24

TYPICAL PERFORMANCE CHARACTERISTICS $T_A = 25^\circ\text{C}$, unless otherwise noted.

Power Good Threshold

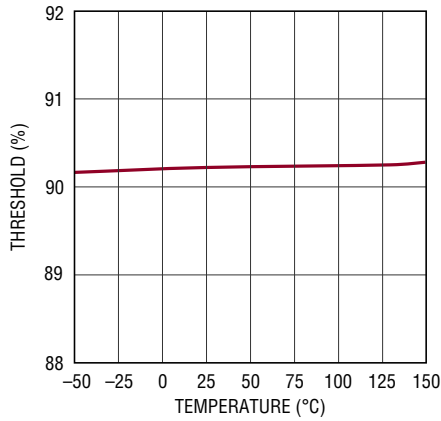

3970 G25

EN Threshold

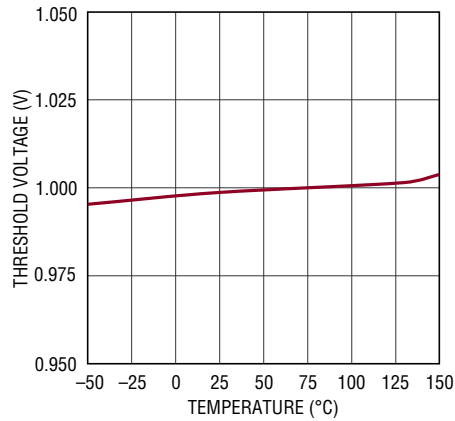

3970 G26

Transient Load Response; Load Current is Stepped from 10mA (Burst Mode Operation) to 110mA

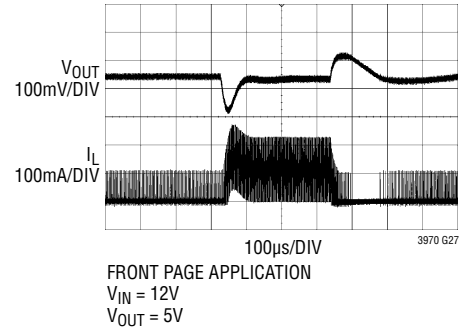

3970 G27

Transient Load Response; Load Current is Stepped from 100mA to 200mA

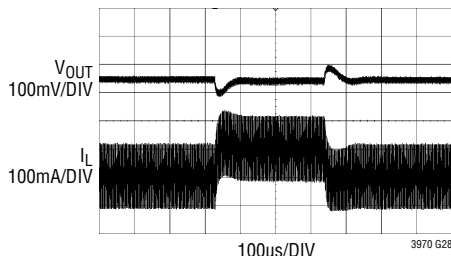

3970 G28

FRONT PAGE APPLICATION
 $V_{IN} = 12\text{V}$
 $V_{OUT} = 5\text{V}$

Switching Waveforms, Burst Mode Operation

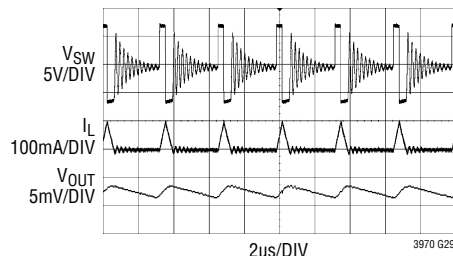

3970 G29

FRONT PAGE APPLICATION
 $V_{IN} = 12\text{V}$
 $V_{OUT} = 5\text{V}$
 $I_{LOAD} = 10\text{mA}$

Switching Waveforms, Full Frequency Continuous Operation

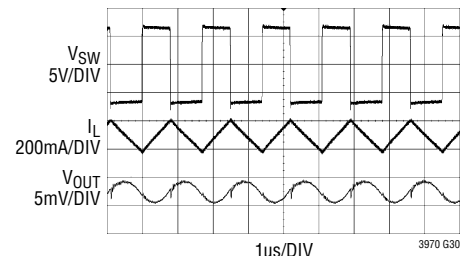

3970 G30

FRONT PAGE APPLICATION
 $V_{IN} = 12\text{V}$
 $V_{OUT} = 5\text{V}$
 $I_{LOAD} = 350\text{mA}$

LT3970 Series

PIN FUNCTIONS

FB (Pin 1, LT3970 Only): The LT3970 Regulates the FB Pin to 1.21V. Connect the feedback resistor divider tap to this pin.

V_{OUT} (Pin 1, LT3970-X Only): The LT3970-3.3, LT3970-3.42 and LT3970-5 regulate the V_{OUT} Pin to 3.3V, 3.42V and 5V respectively. This pin connects to the internal feedback divider that programs the fixed output voltage.

EN (Pin 2): The part is in shutdown when this pin is low and active when this pin is high. The hysteretic threshold voltage is 1V going up and 0.97V going down. Tie to V_{IN} if shutdown feature is not used. The EN threshold is accurate only when V_{IN} is above 4.2V. If V_{IN} is lower than 4.2V, ground EN to place the part in shutdown.

V_{IN} (Pin 3): The V_{IN} pin supplies current to the LT3970's internal circuitry and to the internal power switch. This pin must be locally bypassed.

GND (Pins 4, 5, Exposed Pad (Pin 11, DFN Only)): Ground. Must be soldered to PCB.

SW (Pin 6): The SW pin is the output of an internal power switch. Connect this pin to the inductor.

BOOST (Pin 7): This pin is used to provide a drive voltage, higher than the input voltage, to the internal bipolar NPN power switch.

BD (Pin 8): This pin connects to the anode of the boost diode. This pin also supplies current to the LT3970's internal regulator when BD is above 3.2V.

PG (Pin 9): The PG pin is the open-drain output of an internal comparator. PG remains low until the FB pin is within 10% of the final regulation voltage. PG is valid when V_{IN} is above 4.2V and EN is high.

RT (Pin 10): A resistor is tied between RT and ground to set the switching frequency.

BLOCK DIAGRAM

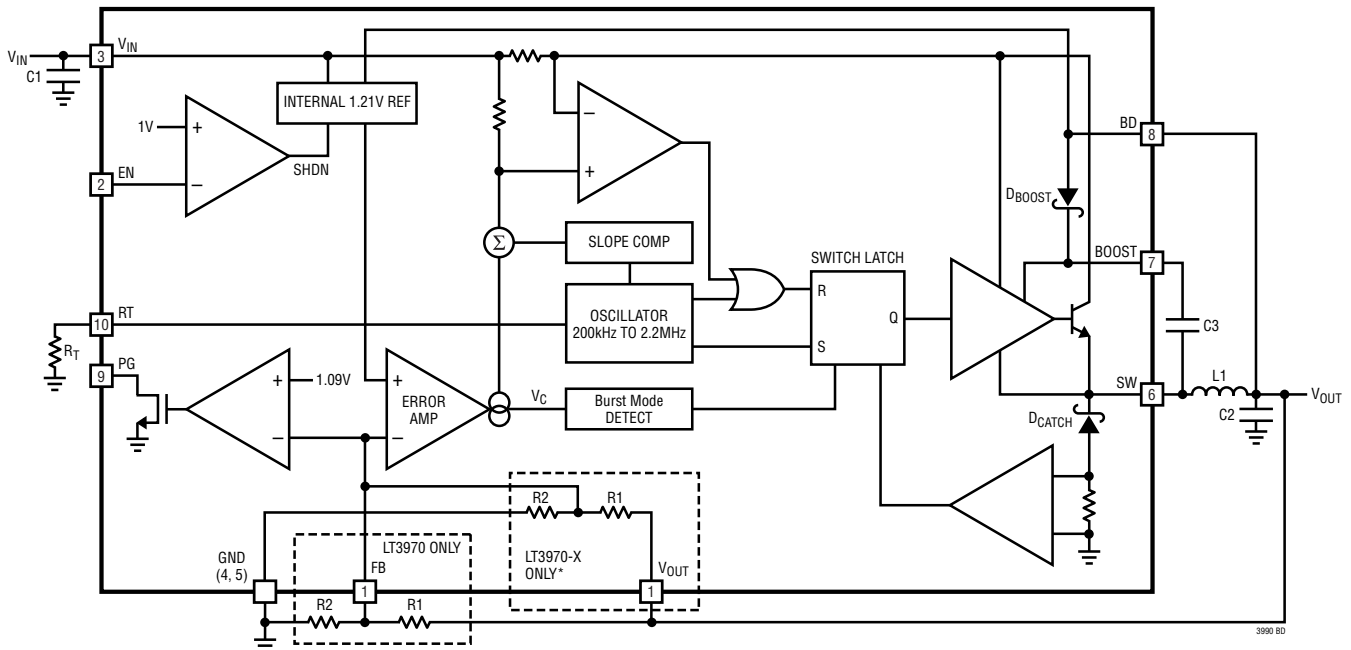

* LT3970-3.3: R₁ = 12.65M, R₂ = 7.35M
LT3970-3.42: R₁ = 12.65M, R₂ = 6.93M
LT3970-5: R₁ = 15.15M, R₂ = 4.85M

OPERATION

The LT3970 is a constant frequency, current mode step-down regulator. An oscillator, with frequency set by RT, sets an RS flip-flop, turning on the internal power switch. An amplifier and comparator monitor the current flowing between the V_{IN} and SW pins, turning the switch off when this current reaches a level determined by the voltage at V_C (see Block Diagram). An error amplifier measures the output voltage through an external resistor divider tied to the FB pin and servos the V_C node. If the error amplifier's output increases, more current is delivered to the output; if it decreases, less current is delivered.

Another comparator monitors the current flowing through the catch diode and reduces the operating frequency when the current exceeds the 400mA bottom current limit. This foldback in frequency helps to control the output current in fault conditions such as a shorted output with high input voltage. Maximum deliverable current to the output is therefore limited by both switch current limit and catch diode current limit.

An internal regulator provides power to the control circuitry. The bias regulator normally draws power from the V_{IN} pin, but if the BD pin is connected to an external voltage higher than 3.2V, bias power will be drawn from the external source (typically the regulated output voltage). This improves efficiency.

If the EN pin is low, the LT3970 is shut down and draws 0.7 μ A from the input. When the EN pin exceeds 1V, the switching regulator will become active.

The switch driver operates from either V_{IN} or from the BOOST pin. An external capacitor is used to generate a voltage at the BOOST pin that is higher than the input supply. This allows the driver to fully saturate the internal bipolar NPN power switch for efficient operation.

To further optimize efficiency, the LT3970 automatically switches to Burst Mode operation in light load situations. Between bursts, all circuitry associated with controlling the output switch is shut down reducing the input supply current to 1.7 μ A.

The LT3970 contains a power good comparator which trips when the FB pin is at 90% of its regulated value. The PG output is an open-drain transistor that is off when the output is in regulation, allowing an external resistor to pull the PG pin high. Power good is valid when the LT3970 is enabled and V_{IN} is above 4.2V.

APPLICATIONS INFORMATION

FB Resistor Network

The output voltage is programmed with a resistor divider between the output and the FB pin. Choose the 1% resistors according to:

$$R1 = R2 \left(\frac{V_{OUT}}{1.21} - 1 \right)$$

Reference designators refer to the Block Diagram. Note that choosing larger resistors will decrease the quiescent current of the application circuit.

Setting the Switching Frequency

The LT3970 uses a constant frequency PWM architecture that can be programmed to switch from 200kHz to 2.2MHz by using a resistor tied from the RT pin to ground. A table showing the necessary R_T value for a desired switching frequency is in Table 1.

Table 1. Switching Frequency vs R_T Value

SWITCHING FREQUENCY (MHz)	R_T VALUE (k Ω)
0.2	768
0.3	499
0.4	357
0.5	280
0.6	226
0.8	158
1.0	124
1.2	100
1.4	80.6
1.6	68.1
1.8	57.6
2.0	49.9
2.2	42.2

Operating Frequency Trade-Offs

Selection of the operating frequency is a trade-off between efficiency, component size, minimum dropout voltage and maximum input voltage. The advantage of high frequency operation is that smaller inductor and capacitor values may be used. The disadvantages are lower efficiency, lower maximum input voltage, and higher dropout voltage. The highest acceptable switching frequency ($f_{SW(MAX)}$) for a given application can be calculated as follows:

$$f_{SW(MAX)} = \frac{V_{OUT} + V_D}{t_{ON(MIN)} (V_{IN} - V_{SW} + V_D)}$$

where V_{IN} is the typical input voltage, V_{OUT} is the output voltage, V_D is the integrated catch diode drop (~0.7V), and V_{SW} is the internal switch drop (~0.5V at max load). This equation shows that slower switching frequency is necessary to accommodate high V_{IN}/V_{OUT} ratio.

Lower frequency also allows a lower dropout voltage. The input voltage range depends on the switching frequency because the LT3970 switch has finite minimum on and off times. The switch can turn on for a minimum of ~150ns and turn off for a minimum of ~160ns (note that the minimum on-time is a strong function of temperature). This means that the minimum and maximum duty cycles are:

$$DC_{MIN} = f_{SW} \cdot t_{ON(MIN)}$$

$$DC_{MAX} = 1 - f_{SW} \cdot t_{OFF(MIN)}$$

where f_{SW} is the switching frequency, the $t_{ON(MIN)}$ is the minimum switch on-time (~150ns), and the $t_{OFF(MIN)}$ is the minimum switch off-time (~160ns). These equations show that duty cycle range increases when switching frequency is decreased.

A good choice of switching frequency should allow adequate input voltage range (see next section) and keep the inductor and capacitor values small.

Input Voltage Range

The minimum input voltage is determined by either the LT3970's minimum operating voltage of 4.2V or by its maximum duty cycle (as explained in previous section). The minimum input voltage due to duty cycle is:

$$V_{IN(MIN)} = \frac{V_{OUT} + V_D}{1 - f_{SW} \cdot t_{OFF(MIN)}} - V_D + V_{SW}$$

where $V_{IN(MIN)}$ is the minimum input voltage, V_{OUT} is the output voltage, V_D is the catch diode drop (~0.7V), V_{SW} is the internal switch drop (~0.5V at max load), f_{SW} is the switching frequency (set by R_T), and $t_{OFF(MIN)}$ is the minimum switch off-time (160ns). Note that higher switching frequency will increase the minimum input voltage. If a lower dropout voltage is desired, a lower switching frequency should be used.

APPLICATIONS INFORMATION

The highest allowed V_{IN} during normal operation ($V_{IN(OP-MAX)}$) is limited by minimum duty cycle and can be calculated by the following equation:

$$V_{IN(OP-MAX)} = \frac{V_{OUT} + V_D}{f_{SW} \cdot t_{ON(MIN)}} - V_D + V_{SW}$$

where $t_{ON(MIN)}$ is the minimum switch on-time (~150ns).

However, the circuit will tolerate inputs up to the absolute maximum ratings of the V_{IN} and BOOST pins, regardless of chosen switching frequency. During such transients where V_{IN} is higher than $V_{IN(OP-MAX)}$, the switching frequency will be reduced below the programmed frequency to prevent damage to the part. The output voltage ripple and inductor current ripple may also be higher than in typical operation, however the output will still be in regulation.

Inductor Selection

For a given input and output voltage, the inductor value and switching frequency will determine the ripple current. The ripple current increases with higher V_{IN} or V_{OUT} and decreases with higher inductance and faster switching frequency. A good starting point for selecting the inductor value is:

$$L = 3 \frac{V_{OUT} + V_D}{f_{SW}}$$

Table 2. Inductor Vendors

VENDOR	URL
Coilcraft	www.coilcraft.com
Sumida	www.sumida.com
Toko	www.tokoam.com
Würth Elektronik	www.we-online.com
Coiltronics	www.cooperet.com
Murata	www.murata.com

where V_D is the voltage drop of the catch diode (~0.7V), L is in μH and f_{SW} is in MHz. The inductor's RMS current rating must be greater than the maximum load current and its saturation current should be about 30% higher. For robust operation in fault conditions (start-up or short circuit) and high input voltage (>30V), the saturation current should be above 500mA. To keep the efficiency high, the series resistance (DCR) should be less than 0.1Ω , and the core material should be intended for high frequency applications. Table 2 lists several vendors and suitable types.

This simple design guide will not always result in the optimum inductor selection for a given application. As a general rule, lower output voltages and higher switching frequency will require smaller inductor values. If the application requires less than 350mA load current, then a lesser inductor value may be acceptable. This allows use of a physically smaller inductor, or one with a lower DCR resulting in higher efficiency. There are several graphs in the Typical Performance Characteristics section of this data sheet that show the maximum load current as a function of input voltage for several popular output voltages. Low inductance may result in discontinuous mode operation, which is acceptable but reduces maximum load current. For details of maximum output current and discontinuous mode operation, see Linear Technology Application Note 44. Finally, for duty cycles greater than 50% ($V_{OUT}/V_{IN} > 0.5$), there is a minimum inductance required to avoid subharmonic oscillations. See Application Note 19.

Input Capacitor

Bypass the input of the LT3970 circuit with a ceramic capacitor of X7R or X5R type. Y5V types have poor performance over temperature and applied voltage, and should not be used. A $1\mu\text{F}$ to $4.7\mu\text{F}$ ceramic capacitor is adequate to bypass the LT3970 and will easily handle the ripple current. Note that larger input capacitance is required

APPLICATIONS INFORMATION

when a lower switching frequency is used (due to longer on-times). If the input power source has high impedance, or there is significant inductance due to long wires or cables, additional bulk capacitance may be necessary. This can be provided with a low performance electrolytic capacitor.

Step-down regulators draw current from the input supply in pulses with very fast rise and fall times. The input capacitor is required to reduce the resulting voltage ripple at the LT3970 and to force this very high frequency switching current into a tight local loop, minimizing EMI. A 1μF capacitor is capable of this task, but only if it is placed close to the LT3970 (see the PCB Layout section). A second precaution regarding the ceramic input capacitor concerns the maximum input voltage rating of the LT3970. A ceramic input capacitor combined with trace or cable inductance forms a high quality (under damped) tank circuit. If the LT3970 circuit is plugged into a live supply, the input voltage can ring to twice its nominal value, possibly exceeding the LT3970's voltage rating. This situation is easily avoided (see the Hot Plugging Safely section).

Output Capacitor and Output Ripple

The output capacitor has two essential functions. It stores energy in order to satisfy transient loads and stabilize the LT3970's control loop. Ceramic capacitors have very low equivalent series resistance (ESR) and provide the best ripple performance. A good starting value is:

$$C_{OUT} = \frac{50}{V_{OUT} \cdot f_{SW}}$$

where f_{SW} is in MHz and C_{OUT} is the recommended output capacitance in μF. Use X5R or X7R types. This choice will provide low output ripple and good transient response. Transient performance can be improved with a higher value capacitor if combined with a phase lead capacitor (typically 22pF) between the output and the feedback pin. A lower value of output capacitor can be used to save space and cost but transient performance will suffer.

The second function is that the output capacitor, along with the inductor, filters the square wave generated by the LT3970 to produce the DC output. In this role it determines the output ripple, so low impedance (at the switching

frequency) is important. The output ripple decreases with increasing output capacitance, down to approximately 1mV. See Figure 1. Note that a larger phase lead capacitor should be used with a large output capacitor.

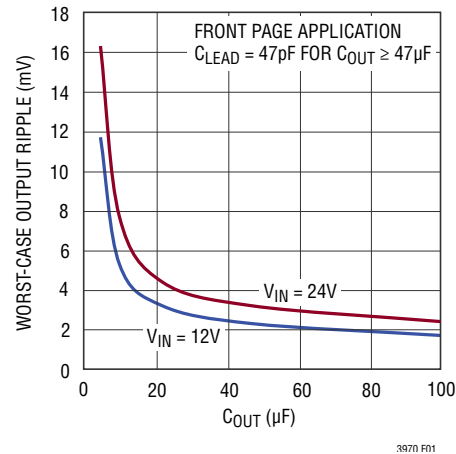

Figure 1. Worst-Case Output Ripple Across Full Load Range

When choosing a capacitor, look carefully through the data sheet to find out what the actual capacitance is under operating conditions (applied voltage and temperature). A physically larger capacitor or one with a higher voltage rating may be required. Table 3 lists several capacitor vendors.

Table 3. Recommended Ceramic Capacitor Vendors

MANUFACTURER	WEBSITE
AVX	www.avxcorp.com
Murata	www.murata.com
Taiyo Yuden	www.t-yuden.com
Vishay Siliconix	www.vishay.com
TDK	www.tdk.com

Ceramic Capacitors

Ceramic capacitors are small, robust and have very low ESR. However, ceramic capacitors can cause problems when used with the LT3970 due to their piezoelectric nature. When in Burst Mode operation, the LT3970's switching frequency depends on the load current, and at very light loads the LT3970 can excite the ceramic capacitor at audio frequencies, generating audible noise. Since the LT3970 operates at a lower current limit during Burst Mode

APPLICATIONS INFORMATION

operation, the noise is typically very quiet to a casual ear. If this is unacceptable, use a high performance tantalum or electrolytic capacitor at the output.

A final precaution regarding ceramic capacitors concerns the maximum input voltage rating of the LT3970. As previously mentioned, a ceramic input capacitor combined with trace or cable inductance forms a high quality (under damped) tank circuit. If the LT3970 circuit is plugged into a live supply, the input voltage can ring to twice its nominal value, possibly exceeding the LT3970's rating. This situation is easily avoided (see the Hot Plugging Safely section).

Low Ripple Burst Mode Operation

To enhance efficiency at light loads, the LT3970 operates in low ripple Burst Mode operation which keeps the output capacitor charged to the proper voltage while minimizing the input quiescent current. During Burst Mode operation, the LT3970 delivers single cycle bursts of current to the output capacitor followed by sleep periods where the output power is delivered to the load by the output capacitor. Because the LT3970 delivers power to the output with single, low current pulses, the output ripple is kept below 5mV for a typical application. See Figure 2.

As the load current decreases towards a no load condition, the percentage of time that the LT3970 operates in sleep mode increases and the average input current is greatly reduced resulting in high efficiency even at very low loads. Note that during Burst Mode operation, the switching frequency will be lower than the programmed switching frequency. See Figure 3.

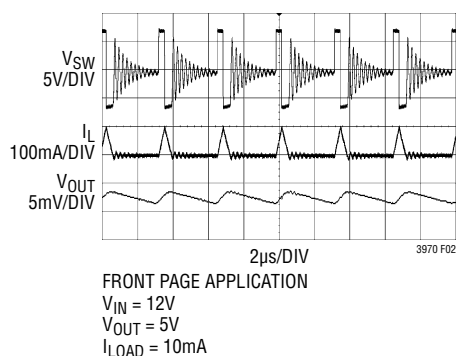

Figure 2. Burst Mode Operation

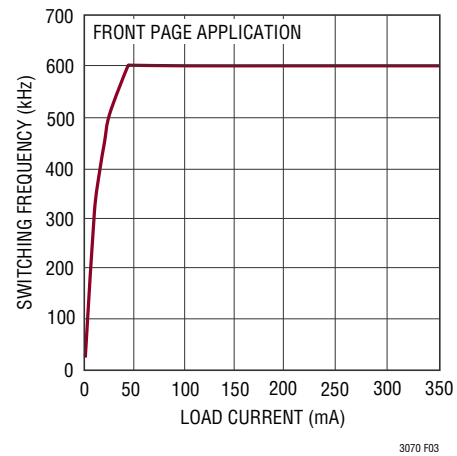

Figure 3. Switching Frequency in Burst Mode Operation

At higher output loads (above ~45mA for the front page application) the LT3970 will be running at the frequency programmed by the R_T resistor, and will be operating in standard PWM mode. The transition between PWM and low ripple Burst Mode is seamless, and will not disturb the output voltage.

BOOST and BD Pin Considerations

Capacitor C3 and the internal boost Schottky diode (see the Block Diagram) are used to generate a boost voltage that is higher than the input voltage. In most cases a 0.22µF capacitor will work well. Figure 4 shows two ways to arrange the boost circuit. The BOOST pin must be more than 1.9V above the SW pin for best efficiency. For outputs of 2.2V and above, the standard circuit (Figure 4a) is best. For outputs between 2.2V and 2.5V, use a 0.47µF boost capacitor. For output voltages below 2.2V, the boost diode can be tied to the input (Figure 4b), or to another external supply greater than 2.2V. However, the circuit in Figure 4a is more efficient because the BOOST pin current and BD pin quiescent current come from a lower voltage source. Also, be sure that the maximum voltage ratings of the BOOST and BD pins are not exceeded.

The minimum operating voltage of an LT3970 application is limited by the minimum input voltage (4.2V) and by the maximum duty cycle as outlined in a previous section. For output voltages greater than 3.4V, the minimum input voltage is also limited by the boost circuit for proper start-up.

APPLICATIONS INFORMATION

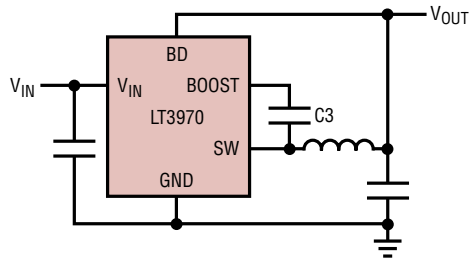

(4a) For $V_{OUT} \geq 2.2V$

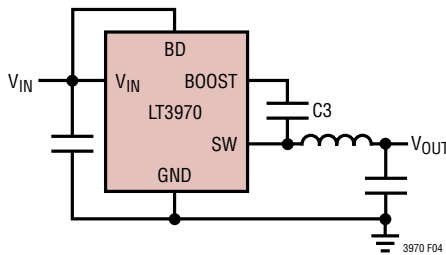

(4b) For $V_{OUT} < 2.2V$; $V_{IN} < 27V$

Figure 4. Two Circuits for Generating the Boost Voltage

If the input voltage is ramped slowly, the boost capacitor may not be fully charged. Because the boost capacitor is charged with the energy stored in the inductor, the circuit will rely on some minimum load current to get the boost circuit running properly. This minimum load will depend on input and output voltages, and on the arrangement of the boost circuit. The minimum load generally goes to zero once the circuit has started. Figure 5 shows a plot of minimum load to start and to run as a function of input voltage. In many cases the discharged output capacitor will present a load to the switcher, which will allow it to start. The plots show the worst-case situation where V_{IN} is ramping very slowly. For lower start-up voltage, the boost diode can be tied to V_{IN} ; however, this restricts the input range to one-half of the absolute maximum rating of the BOOST pin.

Enable Pin

The LT3970 is in shutdown when the EN pin is low and active when the pin is high. The rising threshold of the EN comparator is 1V, with a 30mV hysteresis. This threshold is accurate when V_{IN} is above 4.2V. If V_{IN} is lower than 4.2V, tie EN pin to GND to place the part in shutdown.

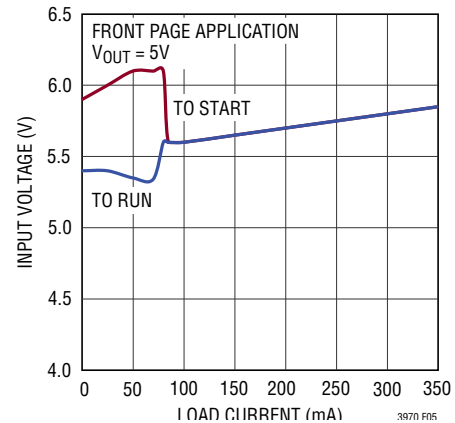
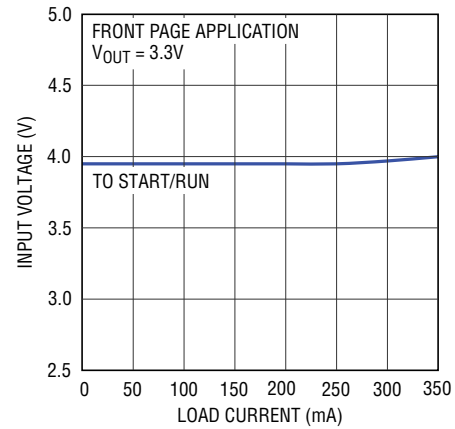

Figure 5. The Minimum Input Voltage Depends on Output Voltage, Load Current and Boost Circuit

Adding a resistor divider from V_{IN} to EN programs the LT3970 to regulate the output only when V_{IN} is above a desired voltage (see Figure 6). This threshold voltage, $V_{IN(EN)}$, can be adjusted by setting the values R3 and R4 such that they satisfy the following equation:

$$V_{IN(EN)} = \frac{R3 + R4}{R4} \cdot 1V$$

where output regulation should not start until V_{IN} is above $V_{IN(EN)}$. Note that due to the comparator's hysteresis, regulation will not stop until the input falls slightly below $V_{IN(EN)}$.

APPLICATIONS INFORMATION

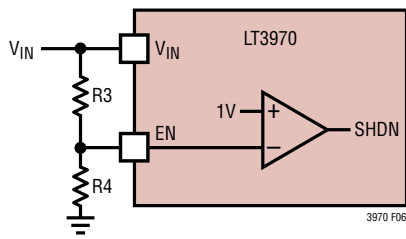

Figure 6. Enable

Be aware that while V_{IN} is below 4.2V, the input current may rise up to several hundred μA and the part may begin to switch while the internal circuitry starts up. Figure 7 shows the startup behavior of a typical application with different programmed $V_{IN(EN)}$.

Shorted and Reversed Input Protection

If the inductor is chosen so that it won't saturate excessively, a LT3970 buck regulator will tolerate a shorted output. There is another situation to consider in systems where the output will be held high when the input to the LT3970 is absent. This may occur in battery charging applications or in battery backup systems where a battery or some other supply is diode ORed with the LT3970's output. If the V_{IN} pin is allowed to float and the EN pin is held high (either by a logic signal or because it is tied to V_{IN}), then the LT3970's internal circuitry will pull its quiescent current through its SW pin. This is fine if the system can tolerate a few μA in this state. If the EN pin is grounded, the SW pin current will drop to 0.7 μA . However, if the V_{IN} pin is grounded while the output is held high, regardless of EN, parasitic diodes inside the LT3970 can pull current from the output through the SW pin and the V_{IN} pin. Figure 8 shows a circuit that will run only when the input voltage is present and that protects against a shorted or reversed input.

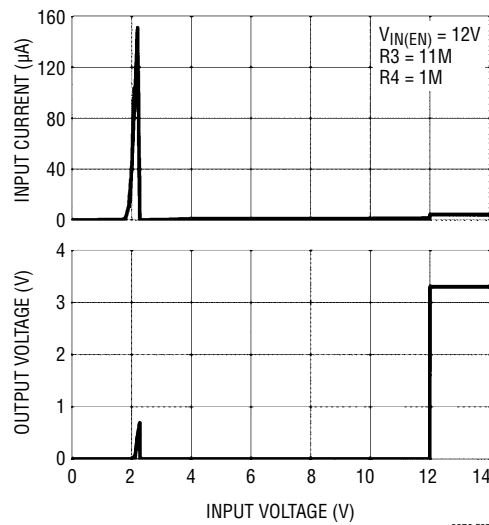
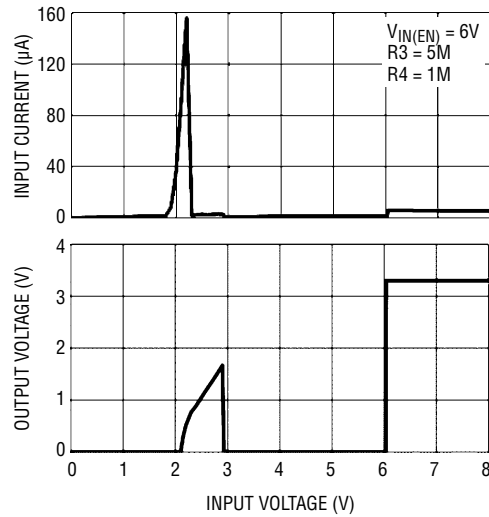

Figure 7. V_{IN} Start-Up of Front Page Application with $V_{OUT} = 3.3\text{V}$, No-Load Current, and $V_{IN(EN)}$ programmed as in Figure 6.

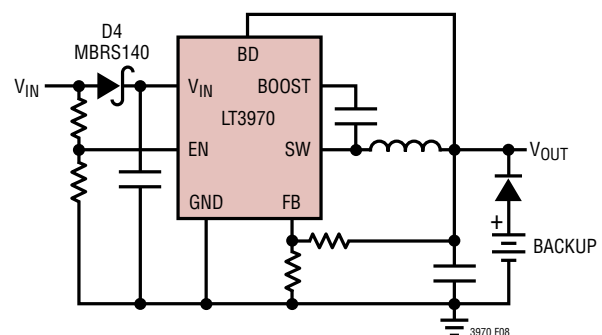

Figure 8. Diode D4 Prevents a Shorted Input from Discharging a Backup Battery Tied to the Output. It Also Protects the Circuit from a Reversed Input. The LT3970 Runs Only when the Input is Present

APPLICATIONS INFORMATION

PCB Layout

For proper operation and minimum EMI, care must be taken during printed circuit board layout. Figure 9 shows the recommended component placement with trace, ground plane and via locations. Note that large, switched currents flow in the LT3970's V_{IN} and SW pins, the internal catch diode and the input capacitor. The loop formed by these components should be as small as possible. These components, along with the inductor and output capacitor, should be placed on the same side of the circuit board, and their connections should be made on that layer. Place a local, unbroken ground plane below these components. The SW and BOOST nodes should be as small as possible. Finally, keep the FB nodes small so that the ground traces will shield them from the SW and BOOST nodes. The Exposed Pad on the bottom of the DFN package must be soldered to ground so that the pad acts as a heat sink. To keep thermal resistance low, extend the ground plane as much as possible, and add thermal vias under and near the LT3970 to additional ground planes within the circuit board and on the bottom side.

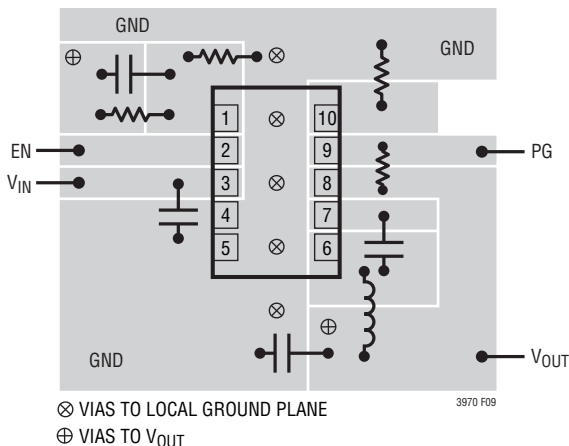

Figure 9. A Good PCB Layout Ensures Proper, Low EMI Operation

Hot Plugging Safely

The small size, robustness and low impedance of ceramic capacitors make them an attractive option for the input bypass capacitor of LT3970 circuits. However, these capacitors can cause problems if the LT3970 is plugged into a live supply. The low loss ceramic capacitor, combined

with stray inductance in series with the power source, forms an under damped tank circuit, and the voltage at the V_{IN} pin of the LT3970 can ring to twice the nominal input voltage, possibly exceeding the LT3970's rating and damaging the part. If the input supply is poorly controlled or the user will be plugging the LT3970 into an energized supply, the input network should be designed to prevent this overshoot. See Linear Technology Application Note 88 for a complete discussion.

High Temperature Considerations

For higher ambient temperatures, care should be taken in the layout of the PCB to ensure good heat sinking of the LT3970. The Exposed Pad on the bottom of the DFN package must be soldered to a ground plane. This ground should be tied to large copper layers below with thermal vias; these layers will spread the heat dissipated by the LT3970. Placing additional vias can reduce thermal resistance further. In the MSOP package, the copper lead frame is fused to GND (Pin 5) so place thermal vias near this pin. The maximum load current should be derated as the ambient temperature approaches the maximum junction rating.

Power dissipation within the LT3970 can be estimated by calculating the total power loss from an efficiency measurement and subtracting inductor loss. The die temperature is calculated by multiplying the LT3970 power dissipation by the thermal resistance from junction to ambient.

Finally, be aware that at high ambient temperatures the internal Schottky diode will have significant leakage current (see Typical Performance Characteristics) increasing the quiescent current of the LT3970 converter.

Other Linear Technology Publications

Application Notes 19, 35 and 44 contain more detailed descriptions and design information for buck regulators and other switching regulators. The LT1376 data sheet has a more extensive discussion of output ripple, loop compensation and stability testing. Design Note 100 shows how to generate a bipolar output supply using a buck regulator.

TYPICAL APPLICATIONS

3.3V Step-Down Converter

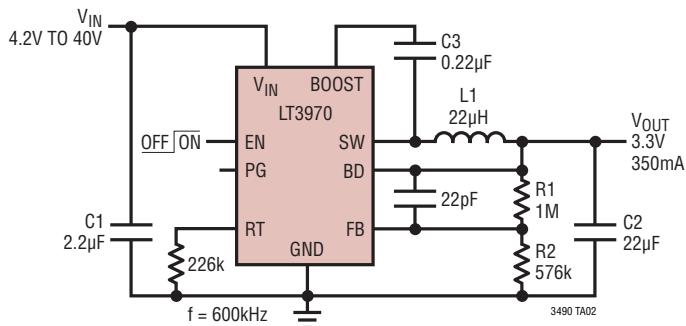

5V Step-Down Converter

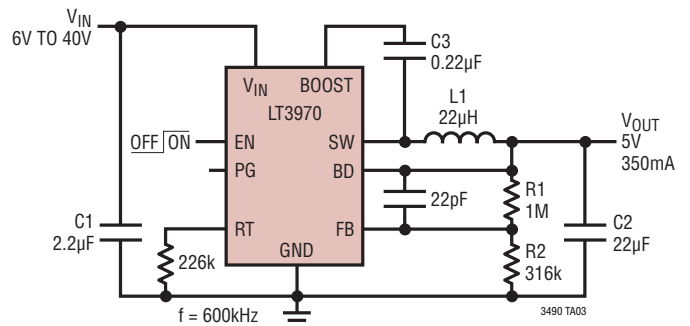

3.3V Step-Down Converter

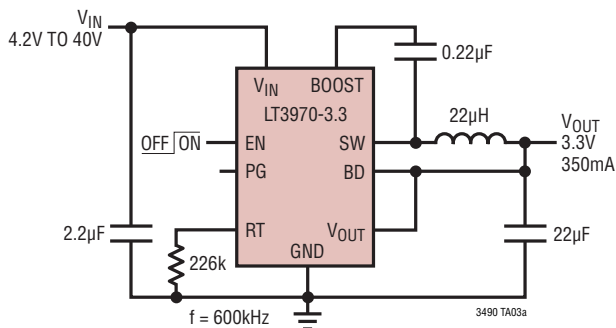

5V Step-Down Converter

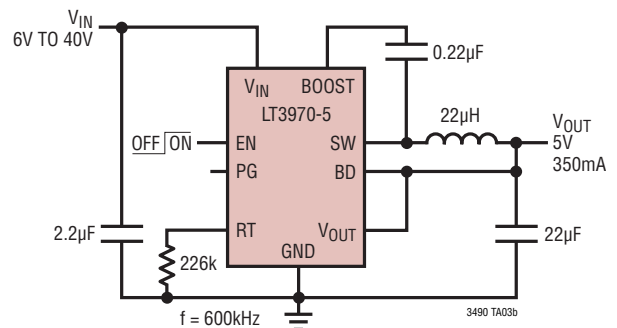

2.5V Step-Down Converter

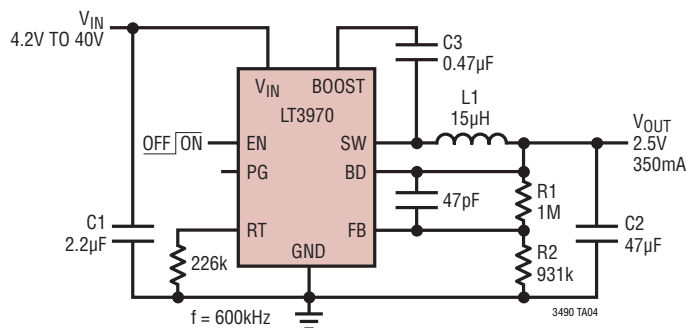

1.8V Step-Down Converter

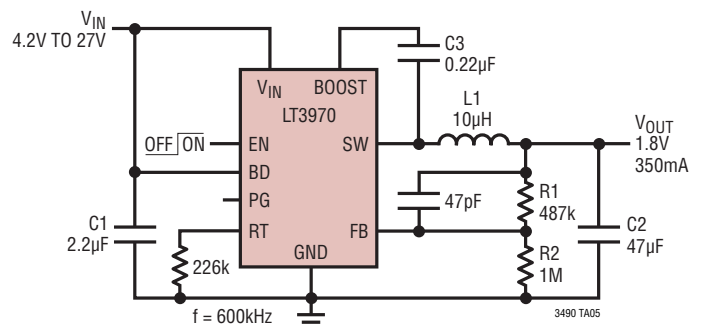

TYPICAL APPLICATIONS

12V Step-Down Converter

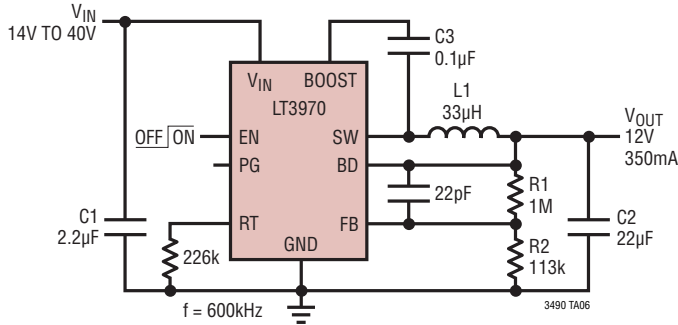

5V, 2MHz Step-Down Converter

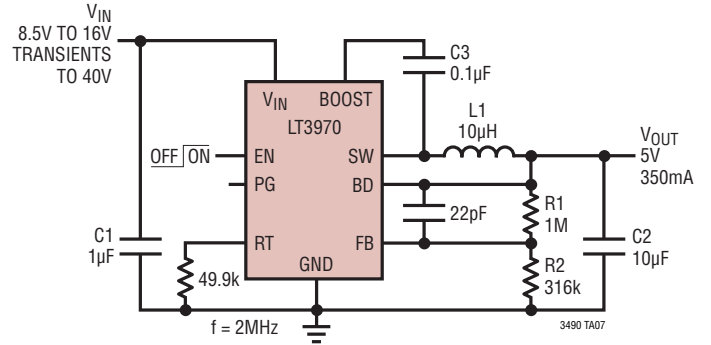

5V Step-Down Converter with Reduced Input Current During Start-Up

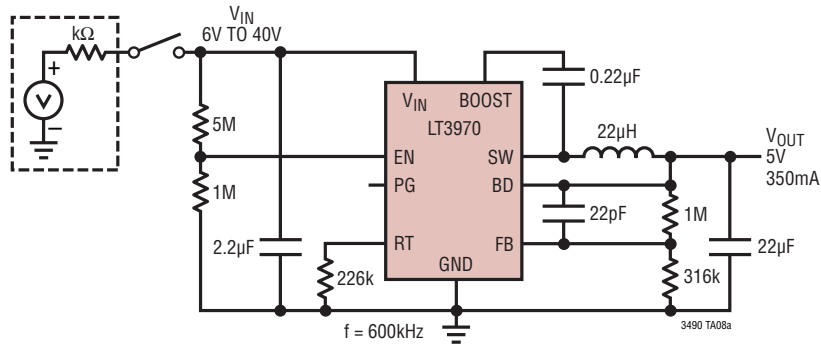

Input Current During Start-Up

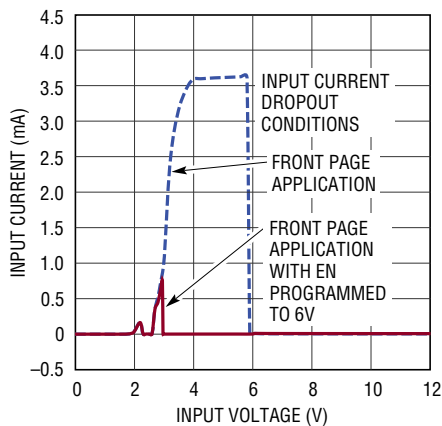

Start-Up from High Impedance Input Source

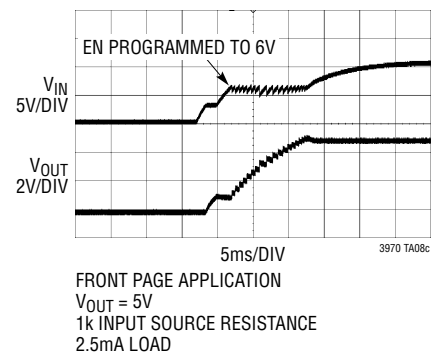

PACKAGE DESCRIPTION

Please refer to <http://www.linear.com/designtools/packaging/> for the most recent package drawings.

DDB Package 10-Lead Plastic DFN (3mm × 2mm) (Reference LTC DWG # 05-08-1722 Rev 0)

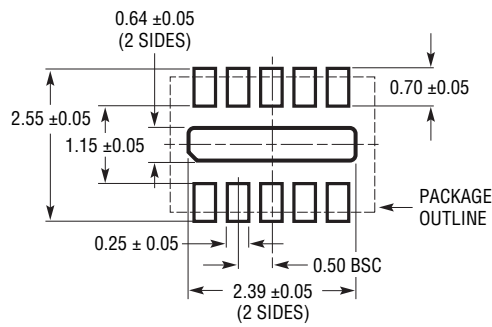

RECOMMENDED SOLDER PAD PITCH AND DIMENSIONS

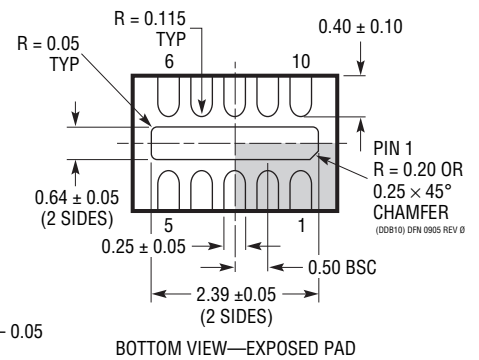
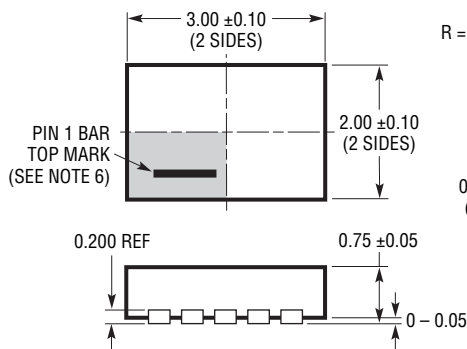

NOTE:

1. DRAWING CONFORMS TO VERSION (WECD-1) IN JEDEC PACKAGE OUTLINE M0-229
2. DRAWING NOT TO SCALE
3. ALL DIMENSIONS ARE IN MILLIMETERS
4. DIMENSIONS OF EXPOSED PAD ON BOTTOM OF PACKAGE DO NOT INCLUDE MOLD FLASH. MOLD FLASH, IF PRESENT, SHALL NOT EXCEED 0.15mm ON ANY SIDE
5. EXPOSED PAD SHALL BE SOLDER PLATED
6. SHADED AREA IS ONLY A REFERENCE FOR PIN 1 LOCATION ON THE TOP AND BOTTOM OF PACKAGE

PACKAGE DESCRIPTION

Please refer to <http://www.linear.com/designtools/packaging/> for the most recent package drawings.

MS Package 10-Lead Plastic MSOP

(Reference LTC DWG # 05-08-1661 Rev E)

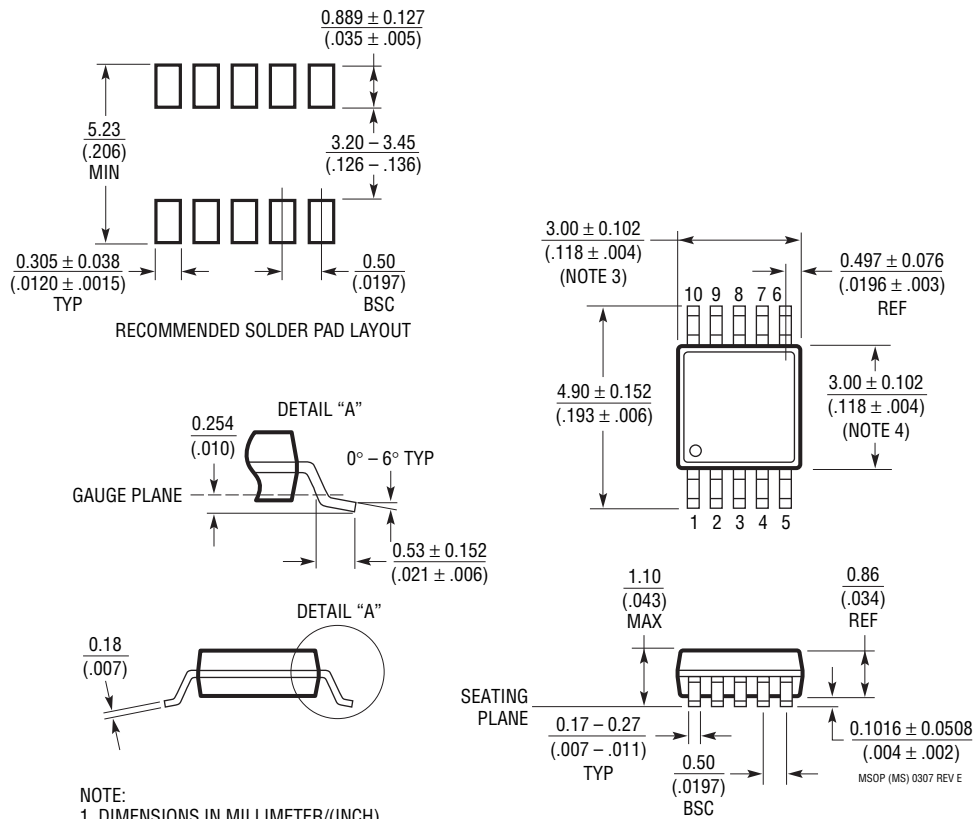

NOTE:

1. DIMENSIONS IN MILLIMETER/(INCH)
2. DRAWING NOT TO SCALE
3. DIMENSION DOES NOT INCLUDE MOLD FLASH, PROTRUSIONS OR GATE BURRS.
MOLD FLASH, PROTRUSIONS OR GATE BURRS SHALL NOT EXCEED 0.152mm (.006") PER SIDE
4. DIMENSION DOES NOT INCLUDE INTERLEAD FLASH OR PROTRUSIONS.
INTERLEAD FLASH OR PROTRUSIONS SHALL NOT EXCEED 0.152mm (.006") PER SIDE
5. LEAD COPLANARITY (BOTTOM OF LEADS AFTER FORMING) SHALL BE 0.102mm (.004") MAX

REVISION HISTORY

REV	DATE	DESCRIPTION	PAGE NUMBER
A	5/10	Added LT3970-3.3 and LT3970-5	1 - 22
B	3/12	Title and Features clarified to add 3.42V fixed output version.	1
		Clarified the Absolute Maximum Ratings section, added 3.42V output option in the Order Information section.	2
		Added 3.42V output option in the Electrical Characteristics table.	3
		Added 3.42V Output Voltage vs Temperature graph.	4
		Clarified V _{OUT} Pin Function and Block Diagram.	8
C	09/13	Added H-grade MSOP-10E version to Order Information table	2
		Clarified Feedback Voltage Specifications to 150°C	3

LT3970 Series

RELATED PARTS

PART NUMBER	DESCRIPTION	COMMENTS
LT3971	38V, 1.2A (I_{OUT}), $I_Q = 2.8\mu A$ High Efficiency Step-Down DC/DC Converter	$V_{IN} = 4.3V$ to 38V, $V_{OUT(MIN)} = 1.2V$, $I_Q = 2.8\mu A$, $I_{SD} < 1\mu A$, MSOP-10E, 3mm \times 3mm DFN-10
LT3991	55V, 1.2A (I_{OUT}), $I_Q = 2.8\mu A$ High Efficiency Step-Down DC/DC Converter	$V_{IN} = 4.3V$ to 55V, $V_{OUT(MIN)} = 1.2V$, $I_Q = 2.8\mu A$, $I_{SD} < 1\mu A$, MSOP-10E, 3mm \times 3mm DFN-10
LT3689	36V, 60V Transient Protection, 800mA, 2.2MHz High Efficiency Micropower Step-Down DC/DC Converter with POR Reset and Watchdog Timer	$V_{IN} = 3.6V$ to 36V, Transient to 60V, $V_{OUT(MIN)} = 0.8V$, $I_Q = 75\mu A$, $I_{SD} < 1\mu A$, 3mm \times 3mm QFN-16
LT3682	36V, 60V _{MAX} , 1A, 2.2MHz High Efficiency Micropower Step-Down DC/DC Converter	$V_{IN} = 3.6V$ to 36V, $V_{OUT(MIN)} = 0.8V$, $I_Q = 75\mu A$, $I_{SD} < 1\mu A$, 3mm \times 3mm DFN-12
LT3480	36V with Transient Protection to 60V, 2A (I_{OUT}), 2.4MHz, High Efficiency Step-Down DC/DC Converter with Burst Mode [®] Operation	$V_{IN} = 3.6V$ to 38V, $V_{OUT(MIN)} = 0.78V$, $I_Q = 70\mu A$, $I_{SD} < 1\mu A$, 3mm \times 3mm DFN-10, MSOP-10E
LT3685	36V with Transient Protection to 60V, 2A (I_{OUT}), 2.4MHz, High Efficiency Step-Down DC/DC Converter	$V_{IN} = 3.6V$ to 38V, $V_{OUT(MIN)} = 0.78V$, $I_Q = 70\mu A$, $I_{SD} < 1\mu A$, 3mm \times 3mm DFN-10, MSOP-10E
LT3481	34V with Transient Protection to 36V, 2A (I_{OUT}), 2.8MHz, High Efficiency Step-Down DC/DC Converter with Burst Mode Operation	$V_{IN} = 3.6V$ to 34V, $V_{OUT(MIN)} = 1.26V$, $I_Q = 50\mu A$, $I_{SD} < 1\mu A$, 3mm \times 3mm DFN-10, MSOP-10E
LT1976/LT1977	60V, 1.2A (I_{OUT}), 200/500kHz, High Efficiency Step-Down DC/DC Converter with Burst Mode Operation	$V_{IN} = 3.3V$ to 60V, $V_{OUT(MIN)} = 1.20V$, $I_Q = 100\mu A$, $I_{SD} < 1\mu A$, TSSOP-16E

Looking for pricing, stock, or lifecycle information?

Click below to explore more details on WIN SOURCE:

 [View LT3970EDDB-3.3#TRPBF on WIN SOURCE](#)

 [Linear Technology](#) Information

Optimize Your Supply Chain with WIN SOURCE Solutions

-  Global Sourcing Solution
-  Obsolete Management
-  Cost Control Management
-  Shortage Management
-  Alternative Solution
-  Excess Inventory Management