



**THE DATASHEET OF
LT3973EDD#PBF**



42V, 750mA Step-Down Regulator with 2.5 μ A Quiescent Current and Integrated Diodes

FEATURES

- **Ultralow Quiescent Current**
 - 2.5 μ A I_Q at 12V_{IN} to 3.3V_{OUT}
- **Low Ripple Burst Mode[®] Operation**
 - Output Ripple < 10mV_{P-P}
- **Wide Input Voltage Range: 4.2V to 42V Operating**
- **Adjustable Switching Frequency: 200kHz to 2.2MHz**
- **Integrated Boost and Catch Diodes**
- **750mA Output Current**
- **Excellent Start-Up and Dropout Performance**
- **Fixed Output Voltages: 3.3V, 5V**
 - 1.9 μ A I_Q at 12V_{IN}
- Accurate Programmable Undervoltage Lockout
- Low Shutdown Current: $I_Q = 0.75\mu$ A
- Internal Catch Diode Current Limit
- Power Good Flag
- Thermal Shutdown
- Small, Thermally Enhanced 10-Lead MSOP and (3mm × 3mm) DFN Packages

APPLICATIONS

- Automotive Battery Regulation
- Power for Portable Products
- Industrial Supplies
- Gate Drive Bias

DESCRIPTION

The LT[®]3973 is an adjustable frequency monolithic buck switching regulator that accepts a wide input voltage range up to 42V, and consumes only 2.5 μ A of quiescent current. A high efficiency switch is included on the die along with the catch diode, boost diode, and the necessary oscillator, control and logic circuitry. Low ripple Burst Mode operation maintains high efficiency at low output currents while keeping the output ripple below 10mV in a typical application. A minimum dropout voltage of 530mV is maintained when the input voltage drops below the programmed output voltage, such as during automotive cold crank. Current mode topology is used for fast transient response and good loop stability. A catch diode current limit provides protection against shorted outputs and overvoltage conditions, with thermal shutdown providing additional fault protection. An accurate programmable undervoltage lockout feature is available, producing a low shutdown current of 0.75 μ A. A power good flag signals when V_{OUT} reaches 90% of the programmed output voltage. The LT3973 is available in small, thermally enhanced 10-lead MSOP and 3mm × 3mm DFN packages.

LT, LT, LTC, LTM, Linear Technology, the Linear logo and Burst Mode are registered trademarks of Linear Technology Corporation. All other trademarks are the property of their respective owners.

TYPICAL APPLICATION

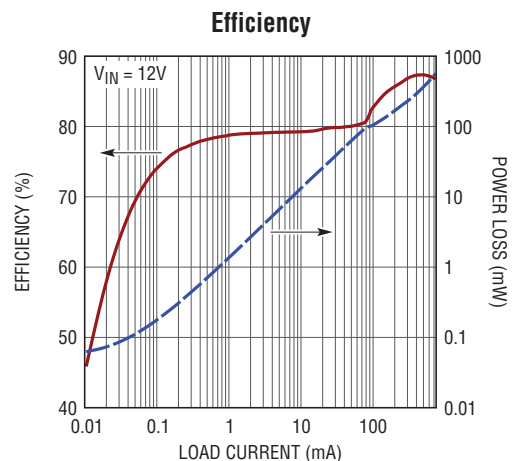
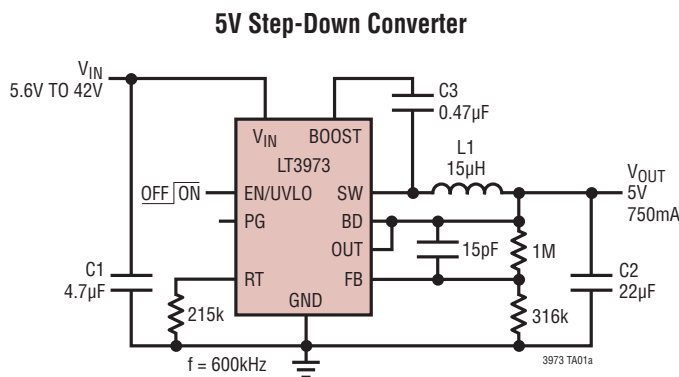

3973 TA01b

3973fb

LT3973/LT3973-3.3/LT3973-5

ABSOLUTE MAXIMUM RATINGS (Note 1)

V_{IN} , EN/UVLO Voltage.....	42V
BOOST Pin Voltage	55V
BOOST Pin Above SW Pin.....	25V
FB/ V_{OUT} , RT, PG Voltage.....	6V
BD Voltage	25V
OUT Voltage.....	14V

Operating Junction Temperature Range (Note 2)	
LT3973E/LT3973E-X.....	-40°C to 125°C
LT3973I/LT3973I-X.....	-40°C to 125°C
LT3973H/LT3973H-X.....	-40°C to 150°C
Storage Temperature Range	
	-65°C to 150°C
Lead Temperature (Soldering, 10 sec)	
MSE Only.....	300°C

PIN CONFIGURATION



* FB for LT3973, V_{OUT} for LT3973-3.3, LT3973-5.

ORDER INFORMATION

LEAD FREE FINISH	TAPE AND REEL	PART MARKING*	PACKAGE DESCRIPTION	TEMPERATURE RANGE
LT3973EDD#PBF	LT3973EDD#TRPBF	LGCH	10-Lead (3mm × 3mm) Plastic DFN	-40°C to 125°C
LT3973IDD#PBF	LT3973IDD#TRPBF	LGCH	10-Lead (3mm × 3mm) Plastic DFN	-40°C to 125°C
LT3973HDD#PBF	LT3973HDD#TRPBF	LGCH	10-Lead (3mm × 3mm) Plastic DFN	-40°C to 150°C
LT3973EMSE#PBF	LT3973EMSE#TRPBF	LTFYS	10-Lead Plastic MSOP	-40°C to 125°C
LT3973IMSE#PBF	LT3973IMSE#TRPBF	LTFYS	10-Lead Plastic MSOP	-40°C to 125°C
LT3973HMSE#PBF	LT3973HMSE#TRPBF	LTFYS	10-Lead Plastic MSOP	-40°C to 150°C
LT3973EMSE-3.3#PBF	LT3973EMSE-3.3#TRPBF	LTGGB	10-Lead Plastic MSOP	-40°C to 125°C
LT3973IMSE-3.3#PBF	LT3973IMSE-3.3#TRPBF	LTGGB	10-Lead Plastic MSOP	-40°C to 125°C
LT3973HMSE-3.3#PBF	LT3973HMSE-3.3#TRPBF	LTGGB	10-Lead Plastic MSOP	-40°C to 150°C
LT3973EDD-3.3#PBF	LT3973EDD-3.3#TRPBF	LGCC	10-Lead (3mm × 3mm) Plastic DFN	-40°C to 125°C
LT3973IDD-3.3#PBF	LT3973IDD-3.3#TRPBF	LGCC	10-Lead (3mm × 3mm) Plastic DFN	-40°C to 125°C
LT3973HDD-3.3#PBF	LT3973HDD-3.3#TRPBF	LGCC	10-Lead (3mm × 3mm) Plastic DFN	-40°C to 150°C
LT3973EMSE-5#PBF	LT3973EMSE-5#TRPBF	LTGGD	10-Lead Plastic MSOP	-40°C to 125°C
LT3973IMSE-5#PBF	LT3973IMSE-5#TRPBF	LTGGD	10-Lead Plastic MSOP	-40°C to 125°C
LT3973HMSE-5#PBF	LT3973HMSE-5#TRPBF	LTGGD	10-Lead Plastic MSOP	-40°C to 150°C

3973fb

ORDER INFORMATION

LEAD FREE FINISH	TAPE AND REEL	PART MARKING*	PACKAGE DESCRIPTION	TEMPERATURE RANGE
LT3973EDD-5#PBF	LT3973EDD-5#TRPBF	LGGF	10-Lead (3mm × 3mm) Plastic DFN	-40°C to 125°C
LT3973IDD-5#PBF	LT3973IDD-5#TRPBF	LGGF	10-Lead (3mm × 3mm) Plastic DFN	-40°C to 125°C
LT3973HDD-5#PBF	LT3973HDD-5#TRPBF	LGGF	10-Lead (3mm × 3mm) Plastic DFN	-40°C to 150°C

Consult LTC Marketing for parts specified with wider operating temperature ranges. *The temperature grade is identified by a label on the shipping container. Consult LTC Marketing for information on non-standard lead based finish parts.

For more information on lead free part marking, go to: <http://www.linear.com/leadfree/>

For more information on tape and reel specifications, go to: <http://www.linear.com/tapeandreel/>

ELECTRICAL CHARACTERISTICS

The ● denotes the specifications which apply over the full operating temperature range, otherwise specifications are at $T_A = 25^\circ\text{C}$. $V_{IN} = 12\text{V}$, $V_{BD} = 3.3\text{V}$ unless otherwise noted. (Note 2)

PARAMETER	CONDITIONS		MIN	TYP	MAX	UNITS
Minimum Input Voltage (Note 3)		●		3.8	4.2	V
Quiescent Current from V_{IN}	$V_{EN/UVLO}$ Low			0.75	1.3	μA
	$V_{EN/UVLO}$ High			1.8	2.8	μA
	$V_{EN/UVLO}$ High, -40°C to 125°C	●			6	μA
	$V_{EN/UVLO}$ High, -40°C to 150°C	●			12	μA
LT3973 Feedback Voltage		●	1.195	1.21	1.225	V
			1.185	1.21	1.235	V
LT3973-3.3 Output Voltage		●	3.26	3.3	3.34	V
			3.234	3.3	3.366	V
LT3973-5 Output Voltage		●	4.94	5	5.06	V
			4.9	5	5.1	V
LT3973 FB Pin Bias Current	$V_{FB} = 1.21\text{V}$	●		0.1	20	nA
FB/Output Voltage Line Regulation	$4.2\text{V} < V_{IN} < 40\text{V}$			0.0002	0.01	%/V
Switching Frequency	$R_T = 41.2\text{k}$, $V_{IN} = 6\text{V}$		1.72	2.15	2.58	MHz
	$R_T = 158\text{k}$, $V_{IN} = 6\text{V}$		632	790	948	kHz
	$R_T = 768\text{k}$, $V_{IN} = 6\text{V}$		156	195	234	kHz
Switch Current Limit	$V_{IN} = 5\text{V}$, $V_{FB} = 0\text{V}$	●	1.237	1.65	1.98	A
Catch Schottky Current Limit	$V_{IN} = 5\text{V}$	●	0.92	1.15	1.44	A
Switch V_{CESAT}	$I_{SW} = 500\text{mA}$			250		mV
Switch Leakage Current				0.05	2	μA
Catch Schottky Forward Voltage	$I_{SCH} = 200\text{mA}$, $V_{IN} = V_{BD} = \text{NC}$			550		mV
Catch Schottky Reverse Leakage	$V_{SW} = 12\text{V}$			0.05	2	μA
Boost Schottky Forward Voltage	$I_{SCH} = 50\text{mA}$, $V_{IN} = \text{NC}$, $V_{BOOST} = 0\text{V}$			820		mV
Boost Schottky Reverse Leakage	$V_{REVERSE} = 12\text{V}$			0.02	2	μA
Minimum Boost Voltage (Note 4)	$V_{IN} = 5\text{V}$	●		1.4	1.8	V
BOOST Pin Current	$I_{SW} = 500\text{mA}$, $V_{BOOST} = 15\text{V}$			10	13	mA
Dropout Comparator Threshold	$(V_{IN} - \text{OUT})$ Falling, $V_{IN} = 5\text{V}$	●	400	490	580	mV
Dropout Comparator Hysteresis				40		mV

LT3973/LT3973-3.3/LT3973-5

ELECTRICAL CHARACTERISTICS

The ● denotes the specifications which apply over the full operating temperature range, otherwise specifications are at $T_A = 25^\circ\text{C}$. $V_{IN} = 12\text{V}$, $V_{BD} = 3.3\text{V}$ unless otherwise noted. (Note 2)

EN/UVLO Pin Current	$V_{EN/UVLO} = 12\text{V}$		1	30	nA	
EN/UVLO Voltage Threshold	EN/UVLO Falling, $V_{IN} \geq 4.2\text{V}$	●	1.09	1.16	1.23	V
EN/UVLO Voltage Threshold	EN/UVLO Rising, $V_{IN} \geq 4.2\text{V}$	●	1.12	1.19	1.28	V
EN/UVLO Voltage Hysteresis			30	45	mV	
PG Threshold Offset from Feedback Voltage	V_{FB} Rising		6.5	10	13.5	%
PG Hysteresis as % of Output Voltage			0.8			%
PG Leakage	$V_{PG} = 3\text{V}$		0.01	1	μA	
PG Sink Current	$V_{PG} = 0.4\text{V}$	●	220	350	μA	
Minimum Switch On-Time			70		ns	
Minimum Switch Off-Time (Note 5)	$V_{IN} = 10\text{V}$		130	180	ns	

Note 1: Stresses beyond those listed under Absolute Maximum Ratings may cause permanent damage to the device. Exposure to any Absolute Maximum Rating condition for extended periods may affect device reliability and lifetime.

Note 2: The LT3973E is guaranteed to meet performance specifications from 0°C to 125°C junction temperature. Specifications over the -40°C to 125°C operating junction temperature range are assured by design, characterization, and correlation with statistical process controls. The LT3973I is guaranteed over the full -40°C to 125°C operating junction temperature range. The LT3973H is guaranteed over the full -40°C to 150°C operating junction temperature range. High junction temperatures degrade operating lifetimes. Operating lifetime is derated at junction temperatures greater than 125°C . The junction temperature (T_J , in $^\circ\text{C}$) is calculated from the ambient temperature (T_A in $^\circ\text{C}$) and power dissipation (PD, in Watts) according to the formula:

$$T_J = T_A + (PD \cdot \theta_{JA})$$

where θ_{JA} (in $^\circ\text{C}/\text{W}$) is the package thermal impedance.

Note 3: This is the minimum input voltage for operation with accurate FB reference voltage.

Note 4: This is the minimum voltage across the boost capacitor needed to guarantee full saturation of the switch.

Note 5: The LT3973 contains circuitry that extends the maximum duty cycle if there is sufficient voltage across the boost capacitor. See the Application Information section for more details.

Note 6: This IC includes overtemperature protection that is intended to protect the device during momentary overload conditions. Junction temperature will exceed the maximum operating junction temperature when overtemperature protection is active. Continuous operation above the specified maximum operating junction temperature may impair device reliability or permanently damage the device.

TYPICAL PERFORMANCE CHARACTERISTICS $T_A = 25^\circ\text{C}$, unless otherwise noted.

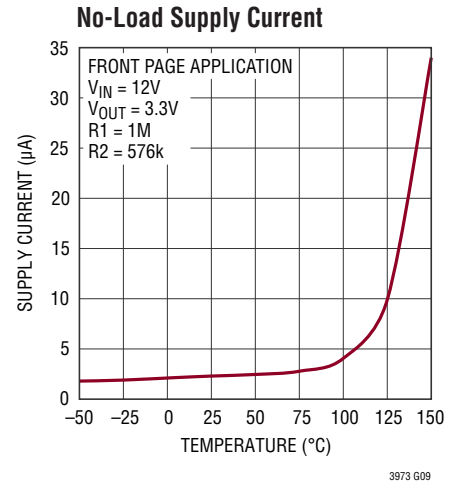
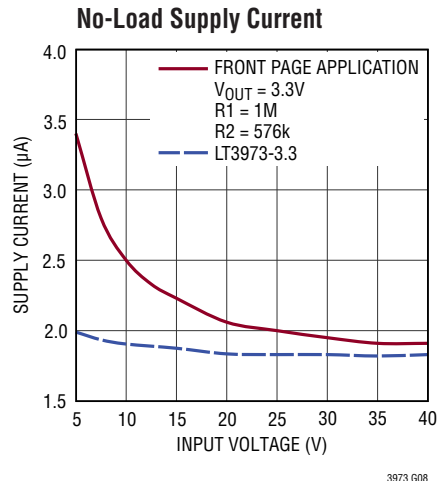
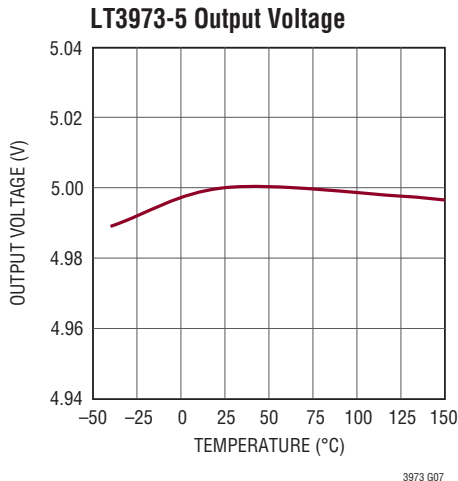
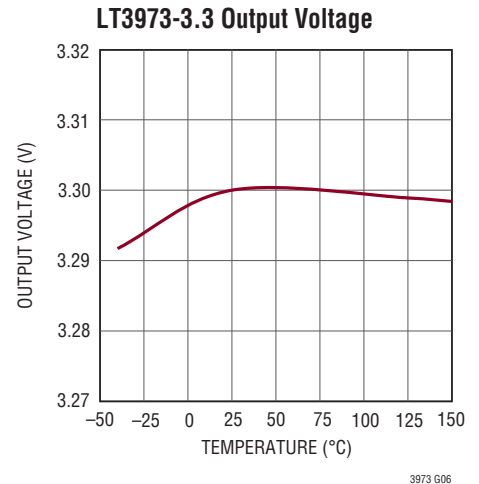
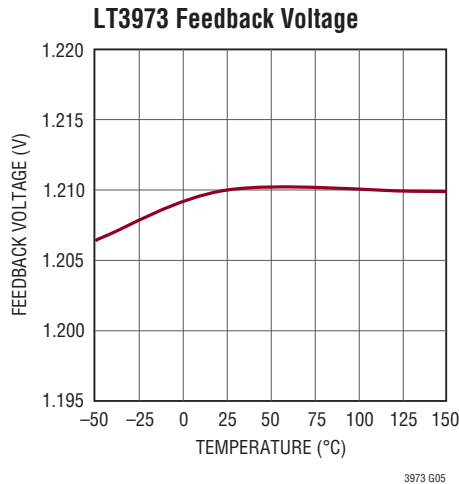
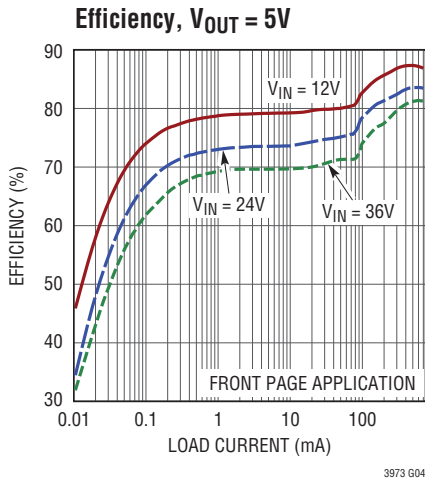
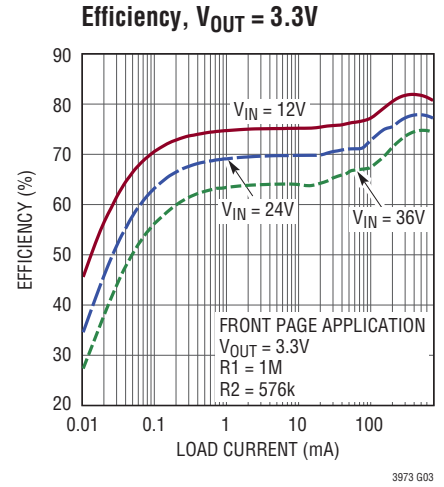
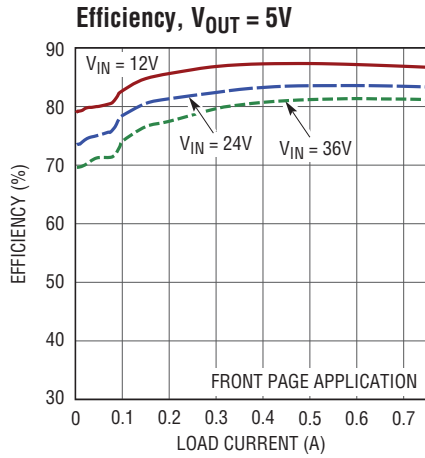
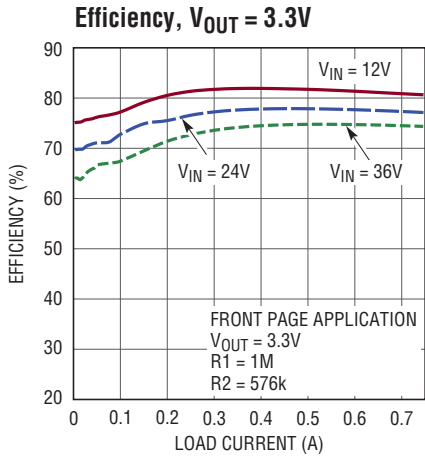

TYPICAL PERFORMANCE CHARACTERISTICS $T_A = 25^\circ\text{C}$, unless otherwise noted.

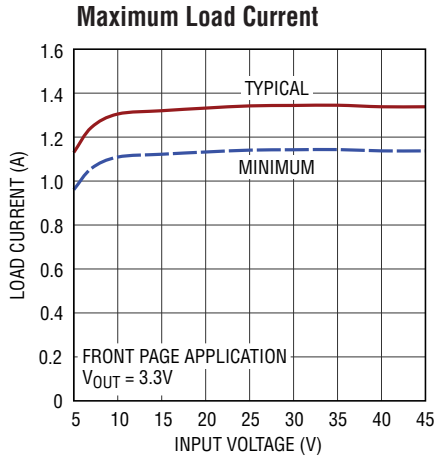

3973 G10

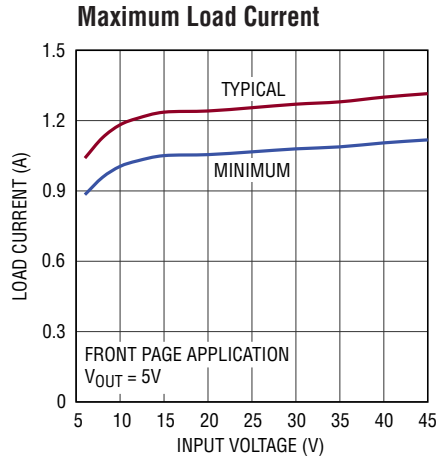

3973 G11

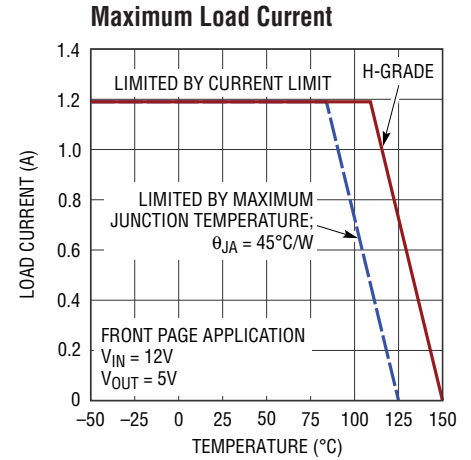

3973 G12

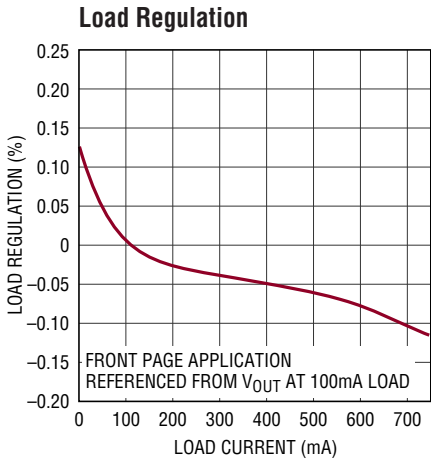

3973 G13

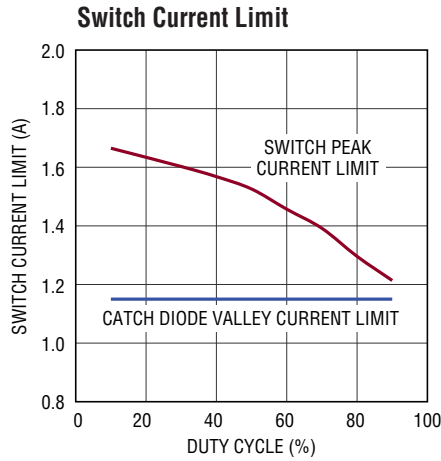

3973 G14

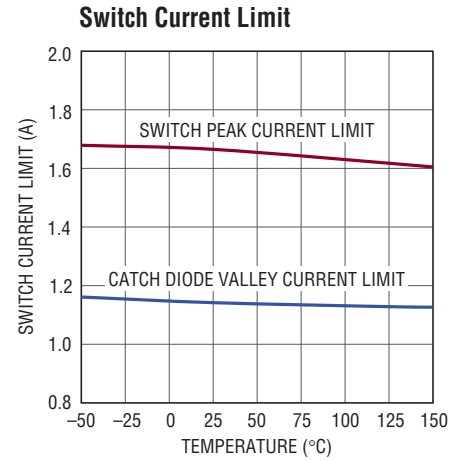

3973 G15

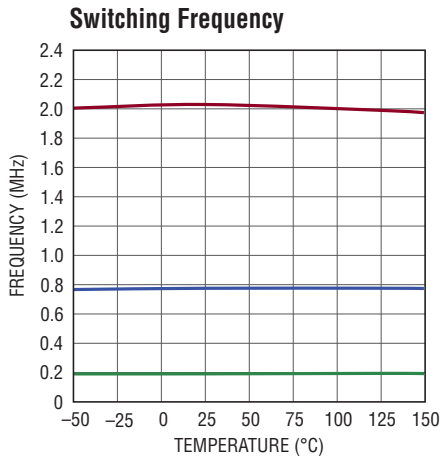

3973 G16

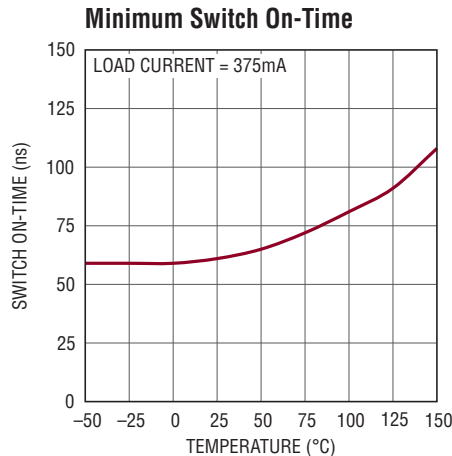

3973 G17

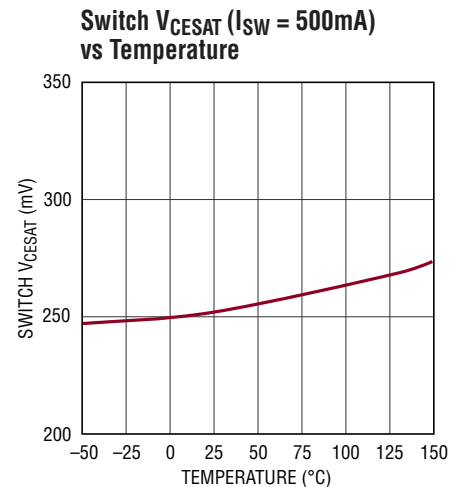

3973 G18

3973fb

TYPICAL PERFORMANCE CHARACTERISTICS $T_A = 25^\circ\text{C}$, unless otherwise noted.

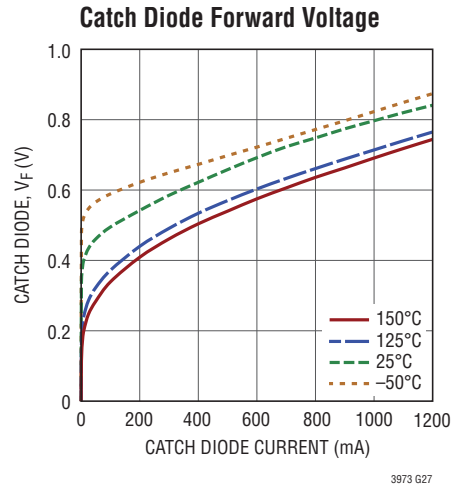
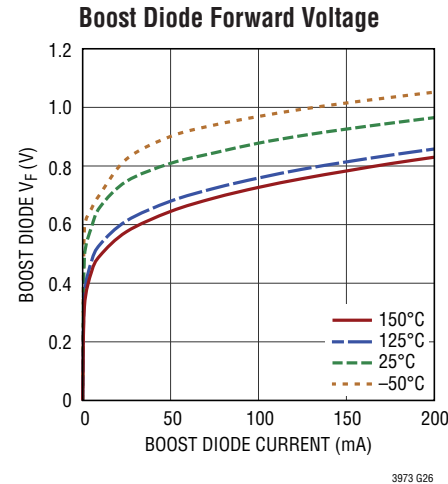
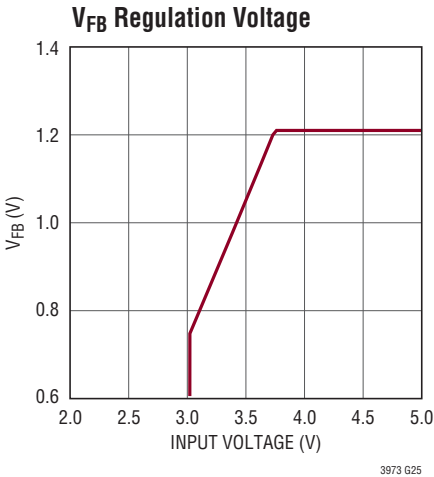
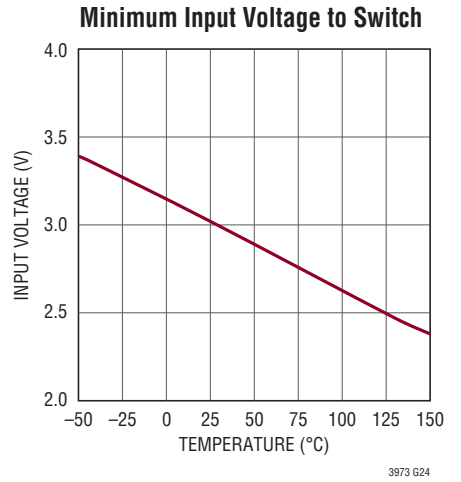
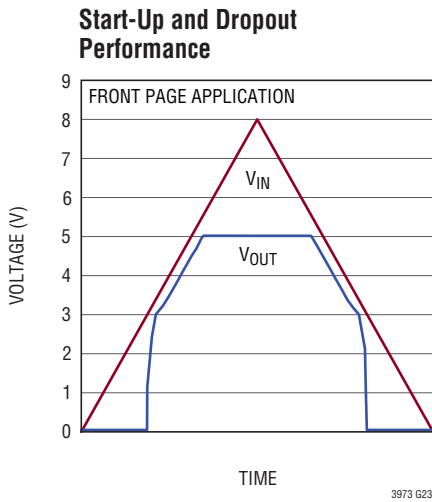
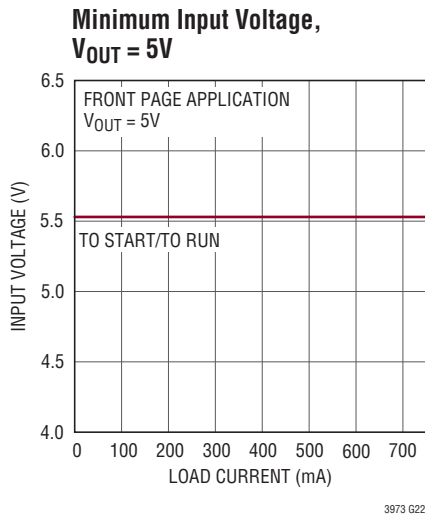
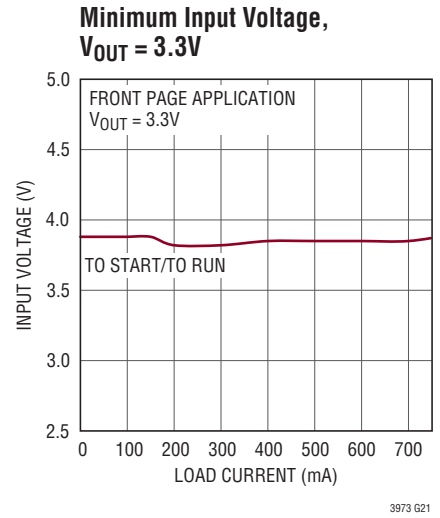
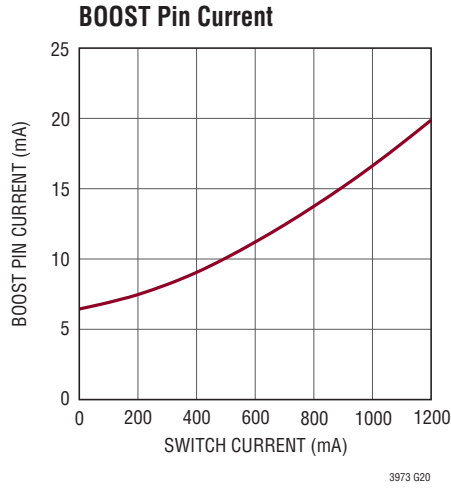
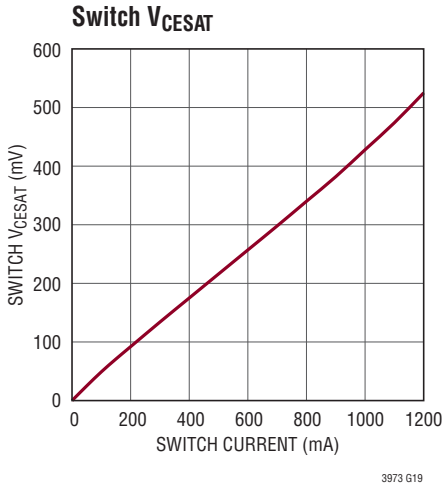

TYPICAL PERFORMANCE CHARACTERISTICS $T_A = 25^\circ\text{C}$, unless otherwise noted.

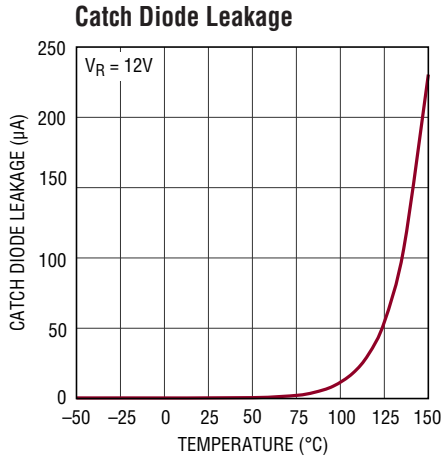

3973 G28

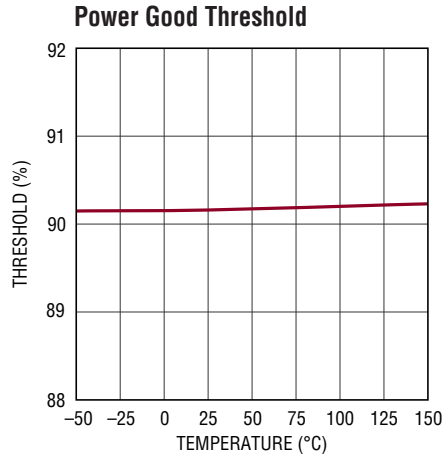

3973 G29

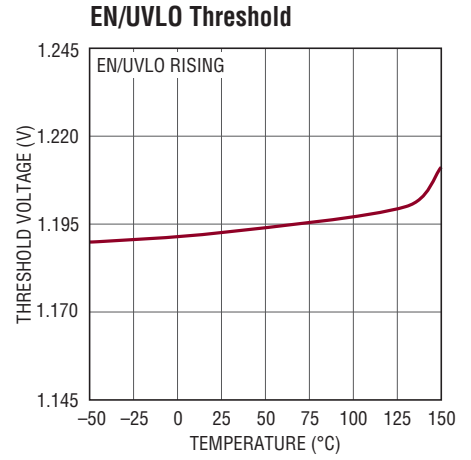

3973 G30

Transient Load Response; Load Current is Stepped from 50mA (Burst Mode Operation) to 300mA

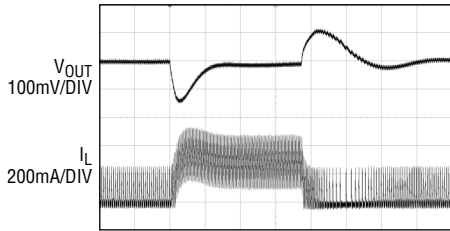

3973 G31

FRONT PAGE APPLICATION
 $V_{IN} = 12\text{V}$
 $V_{OUT} = 5\text{V}$

Transient Load Response; Load Current is Stepped from 250mA to 500mA

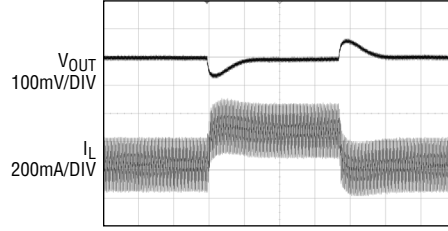

3973 G32

FRONT PAGE APPLICATION
 $V_{IN} = 12\text{V}$
 $V_{OUT} = 5\text{V}$

Switching Waveforms, Burst Mode Operation

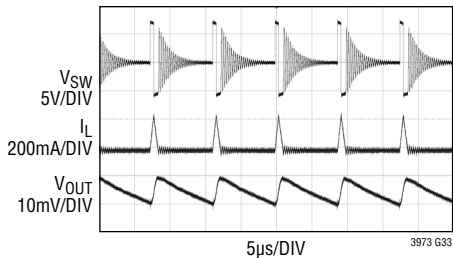

3973 G33

FRONT PAGE APPLICATION
 $V_{IN} = 12\text{V}$
 $V_{OUT} = 5\text{V}$
 $I_{LOAD} = 15\text{mA}$
 $f = 600\text{kHz}$

Switching Waveforms, Full Frequency Continuous Operation

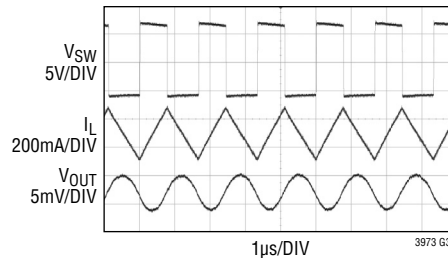

3973 G34

FRONT PAGE APPLICATION
 $V_{IN} = 12\text{V}$
 $V_{OUT} = 5\text{V}$
 $I_{LOAD} = 750\text{mA}$
 $f = 600\text{kHz}$

PIN FUNCTIONS

FB (Pin 1, LT3973 Only): The LT3973 regulates the FB pin to 1.21V. Connect the feedback resistor divider tap to this pin.

V_{OUT} (Pin 1, LT3973-3.3 and LT3973-5 Only): The LT3973-3.3 and LT3973-5 regulate the V_{OUT} pin to 3.3V and 5V, respectively. This pin connects to the internal feedback divider that programs the fixed output voltage.

OUT (Pin 2): The LT3973 regulates the V_{IN} to V_{OUT} voltage for dropout conditions. It will also pull current from this pin to charge the boost capacitor when needed. Connect this pin to the output. If programmed output is greater than 14V, tie this pin to GND.

EN/UVLO (Pin 3): The part is in shutdown when this pin is low and active when this pin is high. The threshold voltage is 1.19V going up with 30mV of hysteresis. Tie to V_{IN} if shutdown feature is not used. The EN/UVLO threshold is accurate only when V_{IN} is above 4.2V. If V_{IN} is lower than 4.2V, ground EN/UVLO to place the part in shutdown.

V_{IN} (Pin 4): The V_{IN} pin supplies current to the LT3973's internal circuitry and to the internal power switch. This pin must be locally bypassed.

GND (Pin 5, Exposed Pad Pin 11): Ground. The exposed pad must be soldered to the PCB.

SW (Pin 6): The SW pin is the output of an internal power switch. Connect this pin to the inductor.

BOOST (Pin 7): This pin is used to provide a drive voltage, higher than the input voltage, to the internal bipolar NPN power switch.

BD (Pin 8): This pin connects to the anode of the boost diode. This pin also supplies current to the LT3973's internal regulator when BD is above 3.2V.

PG (Pin 9): The PG pin is the open-drain output of an internal comparator. PG remains low until the FB pin is within 10% of the final regulation voltage. PG is valid when V_{IN} is above 4.2V and EN/UVLO is high.

RT (Pin 10): A resistor is tied between RT and ground to set the switching frequency.

BLOCK DIAGRAM

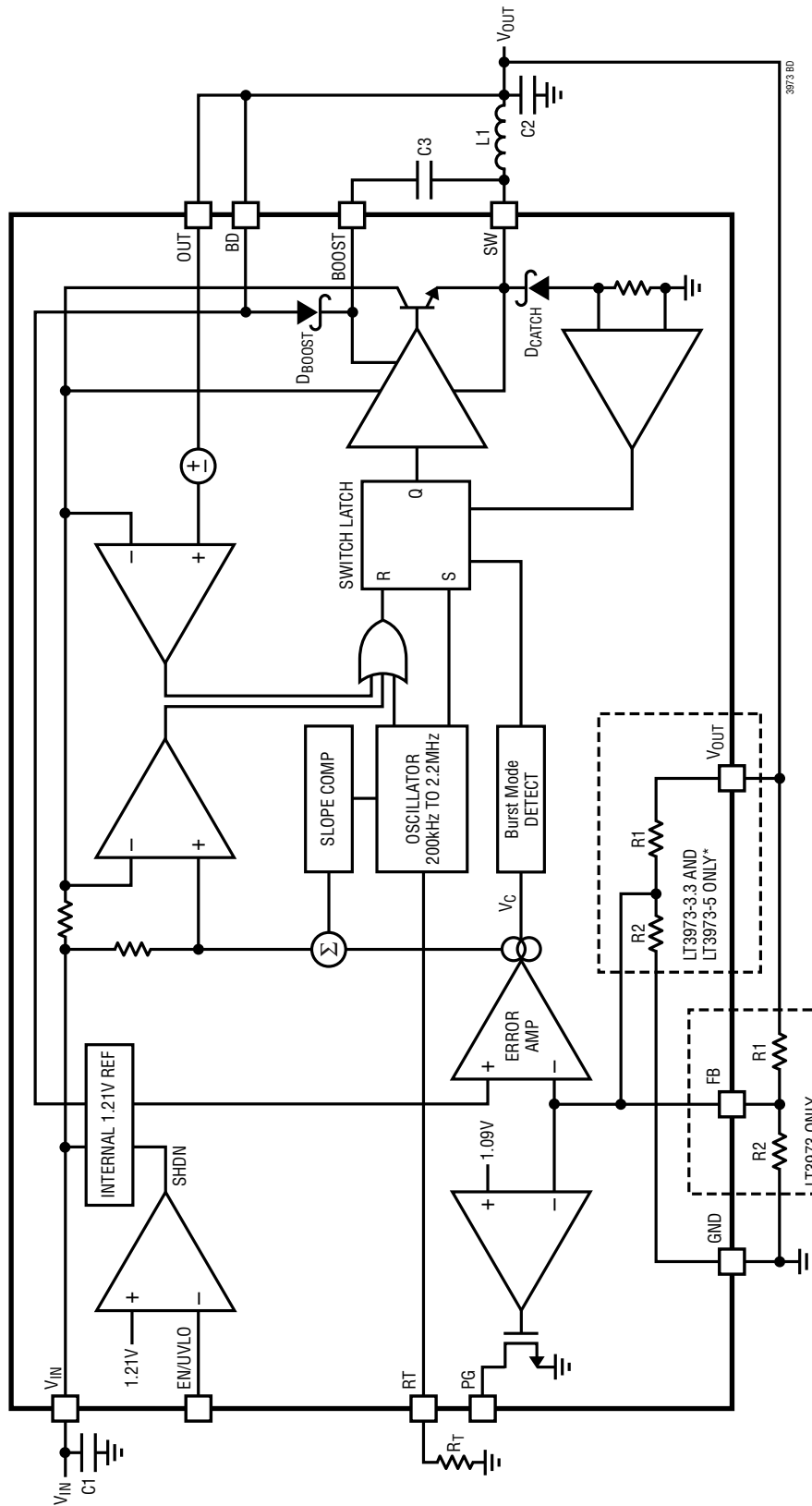

* LT3973-3.3: R1 = 12.72M, R2 = 7.39M
 LT3973-5: R1 = 15.23M, R2 = 4.88M

OPERATION

The LT3973 is a constant frequency, current mode step-down regulator. An oscillator, with frequency set by RT, sets an RS flip-flop, turning on the internal power switch. An amplifier and comparator monitor the current flowing between the V_{IN} and SW pins, turning the switch-off when this current reaches a level determined by the voltage at V_C (see Block Diagram). An error amplifier measures the output voltage through an external resistor divider tied to the FB pin and servos the V_C node. If the error amplifier's output increases, more current is delivered to the output; if it decreases, less current is delivered.

Another comparator monitors the current flowing through the catch diode and reduces the operating frequency when the current exceeds the 1.15A bottom current limit. This foldback in frequency helps to control the output current in fault conditions such as a shorted output with high input voltage. Maximum deliverable current to the output is therefore limited by both switch current limit and catch diode current limit.

An internal regulator provides power to the control circuitry. The bias regulator normally draws power from the V_{IN} pin, but if the BD pin is connected to an external voltage higher than 3.2V, bias power will be drawn from the external source (typically the regulated output voltage). This improves efficiency.

If the EN/UVLO pin is low, the LT3973 is shut down and draws 0.75 μ A from the input. When the EN/UVLO pin exceeds 1.19V, the switching regulator will become active. Under-voltage lockout is programmable via this pin.

The switch driver operates from either V_{IN} or from the BOOST pin. An external capacitor is used to generate a voltage at the BOOST pin that is higher than the input supply. This allows the driver to fully saturate the internal bipolar NPN power switch for efficient operation.

To further optimize efficiency, the LT3973 automatically switches to Burst Mode operation in light load situations. Between bursts, all circuitry associated with controlling the output switch is shut down reducing the input supply current to 1.8 μ A.

If the input voltage decreases towards the programmed output voltage, the LT3973 will start to skip switch-off times and decrease the switching frequency to maintain output regulation up to a maximum duty cycle of approximately 97.5%. When the OUT pin is tied to V_{OUT} , the LT3973 regulates the output such that it stays more than 530mV below V_{IN} ; this sets a minimum dropout voltage. This enforced minimum dropout voltage limits the duty cycle and keeps the boost capacitor charged during dropout conditions. Since sufficient boost voltage is maintained, the internal switch can fully saturate yielding good dropout performance.

The LT3973 contains a power good comparator which trips when the FB pin is at 90% of its regulated value. The PG output is an open-drain transistor that is off when the output is in regulation, allowing an external resistor to pull the PG pin high. Power good is valid when the LT3973 is enabled and V_{IN} is above 4.2V.

APPLICATIONS INFORMATION

FB Resistor Network

The output voltage is programmed with a resistor divider between the output and the FB pin. Choose the 1% resistors according to:

$$R1 = R2 \left(\frac{V_{OUT}}{1.21} - 1 \right)$$

Reference designators refer to the Block Diagram. Note that choosing larger resistors will decrease the quiescent current of the application circuit.

Setting the Switching Frequency

The LT3973 uses a constant frequency PWM architecture that can be programmed to switch from 200kHz to 2.2MHz by using a resistor tied from the RT pin to ground. A table showing the necessary R_T value for a desired switching frequency is in Table 1.

Table 1. Switching Frequency vs R_T Value

SWITCHING FREQUENCY (MHz)	R_T VALUE (k Ω)
0.2	732
0.3	475
0.4	340
0.5	267
0.6	215
0.8	150
1.0	115
1.2	90.9
1.4	73.2
1.6	61.9
1.8	51.1
2.0	43.2
2.2	36.5

Operating Frequency Trade-Offs

Selection of the operating frequency is a trade-off between efficiency, component size, and maximum input voltage. The advantage of high frequency operation is that smaller inductor and capacitor values may be used. The disadvantages are lower efficiency, and narrower input voltage range at constant-frequency. The highest acceptable switching frequency ($f_{SW(MAX)}$) for a given application can be calculated as follows:

$$f_{SW(MAX)} = \frac{V_{OUT} + V_D}{t_{ON(MIN)} (V_{IN} - V_{SW} + V_D)}$$

where V_{IN} is the typical input voltage, V_{OUT} is the output voltage, V_D is the integrated catch diode drop (~0.7V), and V_{SW} is the internal switch drop (~0.5V at max load). This equation shows that slower switching frequency is necessary to accommodate high V_{IN}/V_{OUT} ratio. This is due to the limitation on the LT3973's minimum on-time. The minimum on-time is a strong function of temperature. Use the minimum switch on-time curve (see Typical Performance Characteristics) to design for an application's maximum temperature, while adding about 30% for part-to-part variation. The minimum duty cycle that can be achieved taking this on-time into account is:

$$DC_{MIN} = t_{ON(MIN)} \cdot f_{SW}$$

where f_{SW} is the switching frequency, and the $t_{ON(MIN)}$ is the minimum switch on-time.

A good choice of switching frequency should allow adequate input voltage range (see next two sections) and keep the inductor and capacitor values small.

Minimum Input Voltage Range

The minimum input voltage for regulation is determined by either the LT3973's minimum operating voltage of 4.2V, its maximum duty cycle, or the enforced minimum dropout voltage. See the typical performance characteristics section for the minimum input voltage across load for outputs of 3.3V and 5V.

The duty cycle is the fraction of time that the internal switch is on during a clock cycle. Unlike many fixed frequency regulators, the LT3973 can extend its duty cycle by remaining on for multiple clock cycles. The LT3973 will not switch off at the end of each clock cycle if there is sufficient voltage across the boost capacitor (C3 in the Block Diagram). Eventually, the voltage on the boost capacitor falls and requires refreshing. When this occurs, the switch will turn off, allowing the inductor current to recharge the boost capacitor. This places a limitation on the maximum duty cycle as follows:

$$DC_{MAX} = 1/(1+1/\beta_{SW})$$

where β_{SW} is equal to the SW pin current divided by the BOOST pin current (see the Typical Performance Characteristics section), generally leading to a DC_{MAX} of

APPLICATIONS INFORMATION

about 97.5%. This leads to a minimum input voltage of approximately:

$$V_{IN(MIN1)} = \frac{V_{OUT} + V_D}{DC_{MAX}} - V_D + V_{SW}$$

where V_{OUT} is the output voltage, V_D is the catch diode drop (~0.7V), V_{SW} is the internal switch drop (~0.5V at max load), and DC_{MAX} is the maximum duty cycle.

The final factor affecting the minimum input voltage is the minimum dropout voltage. When the OUT pin is tied to V_{OUT} , the LT3973 regulates the output such that it stays more than 530mV below V_{IN} . This enforced minimum dropout voltage is due to reasons that are covered in a later section. This places a limitation on the minimum input voltage as follows:

$$V_{IN(MIN2)} = V_{OUT} + V_{DROPOUT(MIN)}$$

where V_{OUT} is the output voltage and $V_{DROPOUT(MIN)}$ is the minimum dropout voltage (530mV).

Combining these factors leads to the overall minimum input voltage:

$$V_{IN(MIN)} = \max(V_{IN(MIN1)}, V_{IN(MIN2)}, 4.2V)$$

Note that the LT3973 will begin switching at a lower input voltage (typically 3V) but will regulate to a lower FB voltage in this region of operation (see the Typical Performance Characteristics section).

Maximum Input Voltage Range

The highest allowed V_{IN} during normal operation ($V_{IN(OP-MAX)}$) is limited by minimum duty cycle and can be calculated by the following equation:

$$V_{IN(OP-MAX)} = \frac{V_{OUT} + V_D}{f_{SW} \cdot t_{ON(MIN)}} - V_D + V_{SW}$$

where $t_{ON(MIN)}$ is the minimum switch on time.

However, the circuit will tolerate inputs up to the absolute maximum ratings of the V_{IN} and BOOST pins, regardless of chosen switching frequency. During such transients where V_{IN} is higher than $V_{IN(OP-MAX)}$, the switching frequency will

be reduced below the programmed frequency to prevent damage to the part. The output voltage ripple and inductor current ripple may also be higher than in typical operation, however the output will still be in regulation.

Inductor Selection

For a given input and output voltage, the inductor value and switching frequency will determine the ripple current. The ripple current increases with higher V_{IN} or V_{OUT} and decreases with higher inductance and faster switching frequency. A good starting point for selecting the inductor value is:

$$L = 1.5 \frac{V_{OUT} + V_D}{f_{SW}}$$

where V_D is the voltage drop of the catch diode (~0.7V), L is in μH and f_{SW} is in MHz. The inductor's RMS current rating must be greater than the maximum load current and its saturation current should be about 30% higher. For robust operation in fault conditions (start-up or short circuit) and high input voltage (>30V), the saturation current should be above 1.5A. To keep the efficiency high, the series resistance (DCR) should be less than 0.1 Ω , and the core material should be intended for high frequency applications. Table 2 lists several inductor vendors.

Table 2. Inductor Vendors

VENDOR	URL
Coilcraft	www.coilcraft.com
Sumida	www.sumida.com
Toko	www.tokoam.com
Würth Elektronik	www.we-online.com
Coiltronics	www.cooperet.com
Murata	www.murata.com

This simple design guide will not always result in the optimum inductor selection for a given application. As a general rule, lower output voltages and higher switching frequency will require smaller inductor values. If the application requires less than 750mA load current, then a lesser inductor value may be acceptable. This allows use of a physically smaller inductor, or one with a lower DCR resulting in higher efficiency. There are several graphs in the Typical Performance Characteristics section of this data

APPLICATIONS INFORMATION

sheet that show the maximum load current as a function of input voltage for several popular output voltages. Low inductance may result in discontinuous mode operation, which is acceptable but reduces maximum load current. For details of maximum output current and discontinuous mode operation, see Application Note 44. Finally, for duty cycles greater than 50% ($V_{OUT}/V_{IN} > 0.5$), there is a minimum inductance required to avoid subharmonic oscillations. See Application Note 19.

Input Capacitor

Bypass the input of the LT3973 circuit with a ceramic capacitor of X7R or X5R type. Y5V types have poor performance over temperature and applied voltage, and should not be used. A 4.7 μ F ceramic capacitor is adequate to bypass the LT3973 and will easily handle the ripple current. Note that larger input capacitance is required when a lower switching frequency is used (due to longer on-times). If the input power source has high impedance, or there is significant inductance due to long wires or cables, additional bulk capacitance may be necessary. This can be provided with a low performance electrolytic capacitor.

Step-down regulators draw current from the input supply in pulses with very fast rise and fall times. The input capacitor is required to reduce the resulting voltage ripple at the LT3973 and to force this very high frequency switching current into a tight local loop, minimizing EMI. A 4.7 μ F capacitor is capable of this task, but only if it is placed close to the LT3973 (see the PCB Layout section). A second precaution regarding the ceramic input capacitor concerns the maximum input voltage rating of the LT3973. A ceramic input capacitor combined with trace or cable inductance forms a high quality (under damped) tank circuit. If the LT3973 circuit is plugged into a live supply, the input voltage can ring to twice its nominal value, possibly exceeding the LT3973's voltage rating. This situation is easily avoided (see the Hot Plugging Safely section).

Output Capacitor and Output Ripple

The output capacitor has two essential functions. It stores energy in order to satisfy transient loads and stabilize the LT3973's control loop. Ceramic capacitors have very low

equivalent series resistance (ESR) and provide the best ripple performance. A good starting value is:

$$C_{OUT} = \frac{50}{V_{OUT} \cdot f_{SW}}$$

where f_{SW} is in MHz and C_{OUT} is the recommended output capacitance in μ F. Use X5R or X7R types. This choice will provide low output ripple and good transient response. Transient performance can be improved with a higher value capacitor if combined with a phase lead capacitor (typically 15pF) between the output and the feedback pin. A lower value of output capacitor can be used to save space and cost but transient performance will suffer.

The second function is that the output capacitor, along with the inductor, filters the square wave generated by the LT3973 to produce the DC output. In this role it determines the output ripple, so low impedance (at the switching frequency) is important. The output ripple decreases with increasing output capacitance, down to approximately 1 mV. See Figure 1. Note that a larger phase lead capacitor should be used with a large output capacitor.

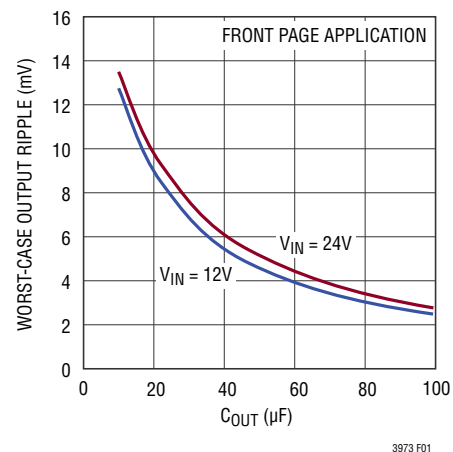

Figure 1. Worst-Case Output Ripple Across Full Load Range

When choosing a capacitor, look carefully through the data sheet to find out what the actual capacitance is under operating conditions (applied voltage and temperature). A physically larger capacitor or one with a higher voltage rating may be required. Table 3 lists several capacitor vendors.

APPLICATIONS INFORMATION

Table 3. Recommended Ceramic Capacitor Vendors

MANUFACTURER	WEBSITE
AVX	www.avxcorp.com
Murata	www.murata.com
Taiyo Yuden	www.t-yuden.com
Vishay Siliconix	www.vishay.com
TDK	www.tdk.com

Ceramic Capacitors

Ceramic capacitors are small, robust and have very low ESR. However, ceramic capacitors can cause problems when used with the LT3973 due to their piezoelectric nature. When in Burst Mode operation, the LT3973's switching frequency depends on the load current, and at very light loads the LT3973 can excite the ceramic capacitor at audio frequencies, generating audible noise. Since the LT3973 operates at a lower current limit during Burst Mode operation, the noise is typically very quiet to a casual ear. If this is unacceptable, use a high performance tantalum or electrolytic capacitor at the output.

A final precaution regarding ceramic capacitors concerns the maximum input voltage rating of the LT3973. As previously mentioned, a ceramic input capacitor combined with trace or cable inductance forms a high quality (under damped) tank circuit. If the LT3973 circuit is plugged into a live supply, the input voltage can ring to twice its nominal value, possibly exceeding the LT3973's rating. This situation is easily avoided (see the Hot Plugging Safely section).

Low Ripple Burst Mode Operation

To enhance efficiency at light loads, the LT3973 operates in low ripple Burst Mode operation which keeps the output capacitor charged to the proper voltage while minimizing the input quiescent current. During Burst Mode operation, the LT3973 delivers single cycle bursts of current to the output capacitor followed by sleep periods where the output power is delivered to the load by the output capacitor. Because the LT3973 delivers power to the output with single, low current pulses, the output ripple is kept below 10mV for a typical application. See Figure 2.

As the load current decreases towards a no load condition, the percentage of time that the LT3973 operates in sleep mode increases and the average input current is

greatly reduced resulting in high efficiency even at very low loads. Note that during Burst Mode operation, the switching frequency will be lower than the programmed switching frequency. See Figure 3.

At higher output loads (above 90mA for the front page application) the LT3973 will be running at the frequency programmed by the R_T resistor, and will be operating in standard PWM mode. The transition between PWM and low ripple Burst Mode is seamless, and will not disturb the output voltage.

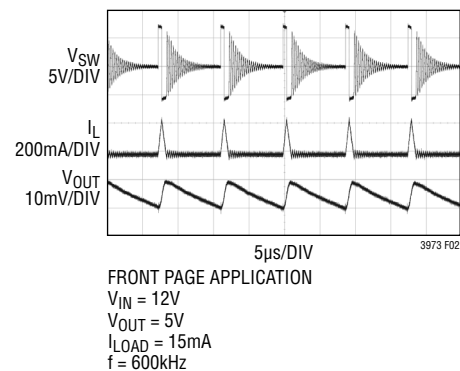

Figure 2. Burst Mode Operation

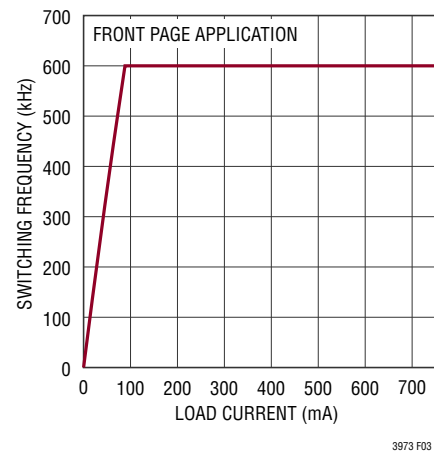

Figure 3. Switching Frequency in Burst Mode Operation

BOOST and BD Pin Considerations

Capacitor C3 and the internal boost Schottky diode (see the Block Diagram) are used to generate a boost voltage that is higher than the input voltage. In most cases a 0.47µF capacitor will work well. Figure 4 shows two ways to arrange the boost circuit. The BOOST pin must be more

APPLICATIONS INFORMATION

than 1.9V above the SW pin for best efficiency. For outputs of 2.2V and above, the standard circuit (Figure 4a) is best. For outputs between 2.2V and 2.5V, use a 1μF boost capacitor. For output voltages below 2.2V, the boost diode can be tied to the input (Figure 4b), or to another external supply greater than 2.2V. However, the circuit in Figure 4a is more efficient because the BOOST pin current and BD pin quiescent current come from a lower voltage source. You must also be sure that the maximum voltage ratings of the BOOST and BD pins are not exceeded.

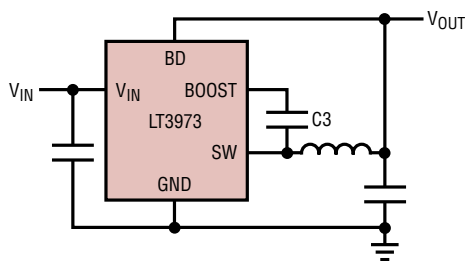

(4a) For $V_{OUT} \geq 2.2V$

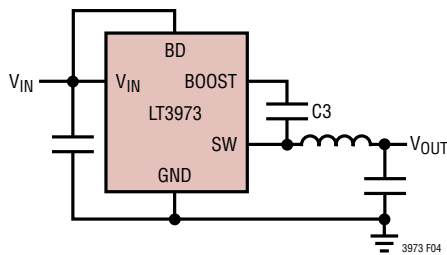

(4b) For $V_{OUT} < 2.2V$; $V_{IN} < 25V$

Figure 4. Two Circuits for Generating the Boost Voltage

The LT3973 monitors the boost capacitor for sufficient voltage such that the switch is allowed to fully saturate. During start-up conditions when the boost capacitor may not be fully charged, the switch will operate with about 1V of drop, and an internal current source will begin to pull 70mA (typical) from the OUT pin which is typically connected to V_{OUT} . This current forces the LT3973 to switch more often and with more inductor current, which recharges the boost capacitor. When the boost capacitor is sufficiently charged, the current source turns off, and the part may enter Burst Mode. See Figure 5 for minimum input voltage for outputs of 3.3V and 5V.

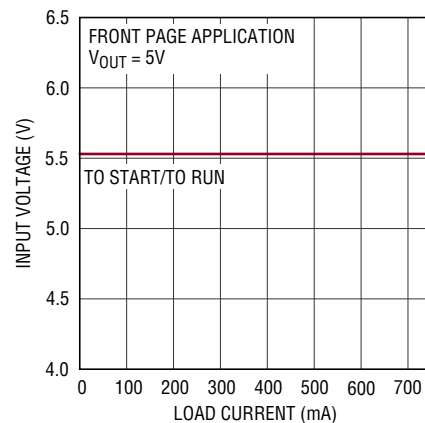
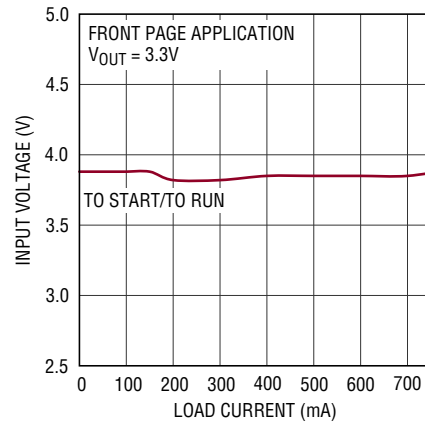

3973 F05

Figure 5. The Minimum Input Voltage Depends on Output Voltage, Load Current and Boost Circuit

Minimum Dropout Voltage

When the OUT pin is tied to V_{OUT} , the LT3973 regulates the output such that:

$$V_{IN} - V_{OUT} > V_{DROPOUT(MIN)}$$

where $V_{DROPOUT(MIN)}$ is 530mV. This enforced minimum dropout voltage keeps the boost capacitor charged regardless of load during dropout conditions. The LT3973 achieves this by limiting the duty cycle and forcing the switch to turn off regularly to charge the boost capacitor. Since sufficient voltage across the boost capacitor is maintained, the switch is allowed to fully saturate and the internal switch drop stays low for good dropout performance. Figure 6 shows the overall V_{IN} to V_{OUT} performance during start-up and dropout conditions.

3973fb

APPLICATIONS INFORMATION

During dropout conditions when the output is below regulation, the output ripple may increase. At very high loads, this ripple can increase to approximately 200mV for the front page application. If lower output ripple is desired during such conditions, a larger output capacitor can be used.

In order to not exceed the maximum voltage rating, tie the OUT pin to GND for programmed outputs greater than 14V. Note that this will result in degraded start-up and dropout performance.

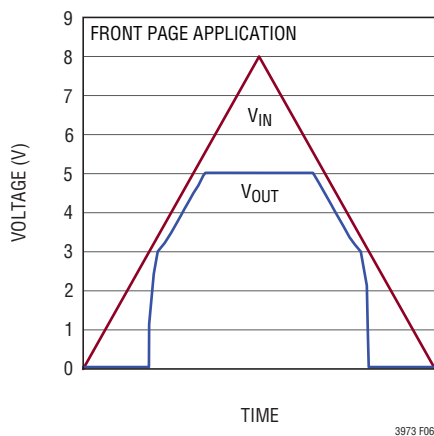

Figure 6. V_{IN} to V_{OUT} Performance

Enable and Undervoltage Lockout

The LT3973 is in shutdown when the EN/UVLO pin is low and active when the pin is high. The rising threshold of the EN/UVLO comparator is 1.19V, with a 30mV hysteresis. This threshold is accurate when V_{IN} is above 4.2V. If V_{IN} is lower than 4.2V, tie EN/UVLO pin to GND to place the part in shutdown.

Figure 7 shows how to add undervoltage lockout (UVLO) to the LT3973. Typically, UVLO is used in situations where the input supply is current limited, or has a relatively high source resistance. A switching regulator draws constant power from the source, so source current increases as source voltage drops. This looks like a negative resistance load to the source and can cause the source to current limit or latch low under low source voltage conditions. UVLO prevents the regulator from operating at source voltages where the problems might occur. The UVLO threshold can be adjusted by setting the values R3 and R4 such that they satisfy the following equation:

$$V_{UVLO} = \frac{R3 + R4}{R4} \cdot 1.19V$$

where switching should not start until V_{IN} is above V_{UVLO} . Note that due to the comparator's hysteresis, switching will not stop until the input falls slightly below V_{UVLO} . Undervoltage lockout is functional only when V_{UVLO} is greater than 5.5V.

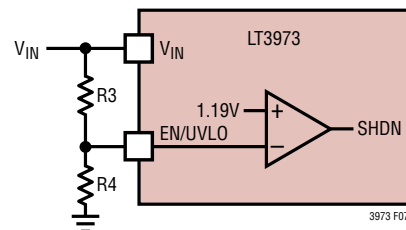

Figure 7. Undervoltage Lockout

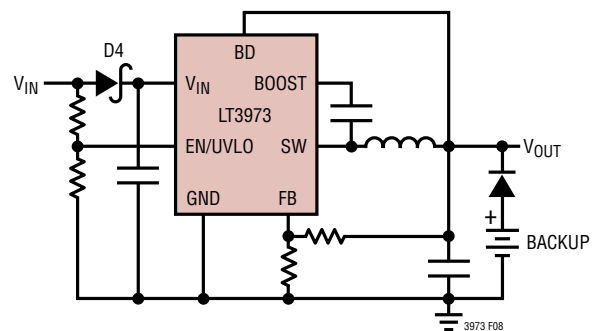

Figure 8. Diode D4 Prevents a Shorted Input from Discharging a Backup Battery Tied to the Output. It Also Protects the Circuit from a Reversed Input. The LT3973 Runs Only When the Input Is Present

Shorted and Reversed Input Protection

If the inductor is chosen so that it won't saturate excessively, a LT3973 buck regulator will tolerate a shorted output. There is another situation to consider in systems where the output will be held high when the input to the LT3973 is absent. This may occur in battery charging applications or in battery backup systems where a battery or some other supply is diode ORed with the LT3973's output. If the V_{IN} pin is allowed to float and the EN/UVLO pin is held high (either by a logic signal or because it is tied to V_{IN}), then the LT3973's internal circuitry will pull its quiescent current through its SW pin. This is fine if the system can tolerate

APPLICATIONS INFORMATION

a few μA in this state. If the EN/UVLO pin is grounded, the SW pin current will drop to $0.75\mu\text{A}$. However, if the V_{IN} pin is grounded while the output is held high, regardless of EN/UVLO, parasitic diodes inside the LT3973 can pull current from the output through the SW pin and the V_{IN} pin. Figure 8 shows a circuit that will run only when the input voltage is present and that protects against a shorted or reversed input.

PCB Layout

For proper operation and minimum EMI, care must be taken during printed circuit board layout. Figure 9 shows the recommended component placement with trace, ground plane and via locations. Note that large, switched currents flow in the LT3973's V_{IN} and SW pins, the internal catch diode and the input capacitor. The loop formed by these components should be as small as possible. These components, along with the inductor and output capacitor, should be placed on the same side of the circuit board, and their connections should be made on that layer. Place a local, unbroken ground plane below these components. The SW and BOOST nodes should be as small as possible. Finally, keep the FB nodes small so that the ground traces will shield them from the SW and BOOST nodes. The exposed pad on the bottom must be soldered to ground so that the pad acts as a heat sink. To keep thermal resistance low, extend the ground plane as much as possible, and add thermal vias under and near the LT3973 to additional ground planes within the circuit board and on the bottom side.

Hot Plugging Safely

The small size, robustness and low impedance of ceramic capacitors make them an attractive option for the input bypass capacitor of LT3973 circuits. However, these capacitors can cause problems if the LT3973 is plugged into a live supply. The low loss ceramic capacitor, combined with stray inductance in series with the power source, forms an under damped tank circuit, and the voltage at the V_{IN} pin of the LT3973 can ring to twice the nominal input voltage, possibly exceeding the LT3973's rating and damaging the part. If the input supply is poorly controlled or the user will be plugging the LT3973 into an energized supply, the input network should be designed to prevent this overshoot. See Application Note 88 for a complete discussion.

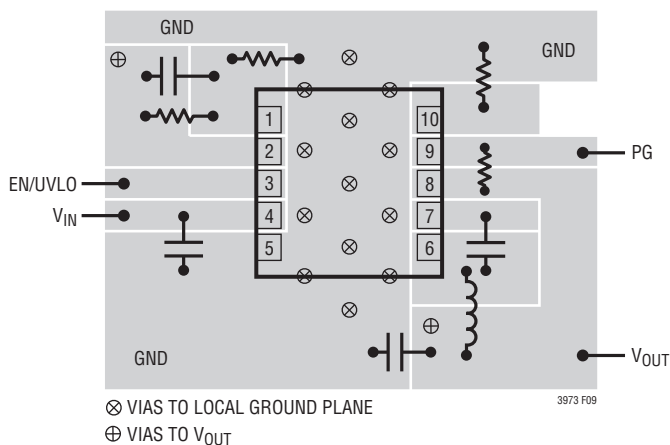

Figure 9. A Good PCB Layout Ensures Proper, Low EMI Operation

High Temperature Considerations

For higher ambient temperatures, care should be taken in the layout of the PCB to ensure good heat sinking of the LT3973. The exposed pad on the bottom must be soldered to a ground plane. This ground should be tied to large copper layers below with thermal vias; these layers will spread the heat dissipated by the LT3973. Placing additional vias can reduce thermal resistance further. The maximum load current should be derated as the ambient temperature approaches the maximum junction rating.

Power dissipation within the LT3973 can be estimated by calculating the total power loss from an efficiency measurement and subtracting inductor loss. The die temperature is calculated by multiplying the LT3973 power dissipation by the thermal resistance from junction to ambient.

Finally, be aware that at high ambient temperatures the internal Schottky diode will have significant leakage current (see the Typical Performance Characteristics section) increasing the quiescent current of the LT3973 converter.

Other Linear Technology Publications

Application Notes 19, 35 and 44 contain more detailed descriptions and design information for buck regulators and other switching regulators. The LT1376 data sheet has a more extensive discussion of output ripple, loop compensation and stability testing. Design Note 100 shows how to generate a bipolar output supply using a buck regulator.

TYPICAL APPLICATIONS

3.3V Step-Down Converter

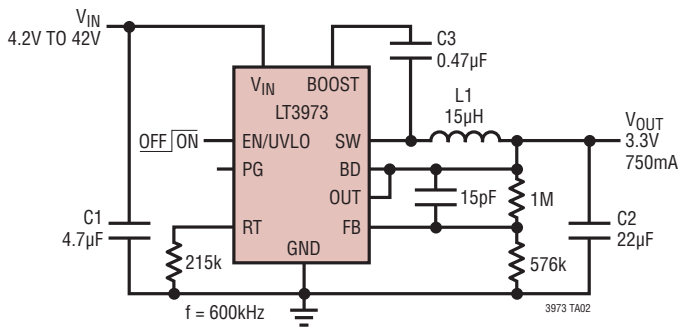

5V Step-Down Converter

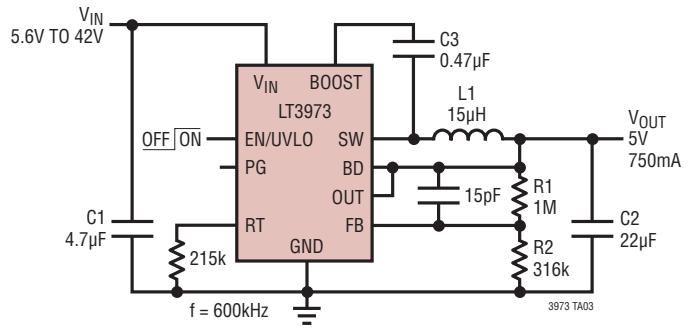

3.3V Step-Down Converter

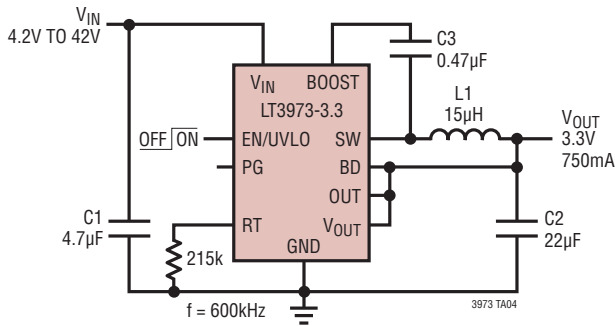

5V Step-Down Converter

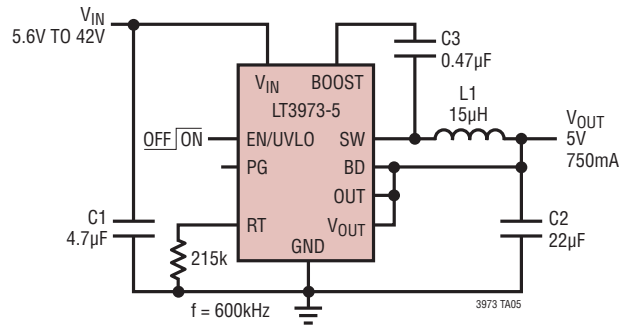

2.5V Step-Down Converter

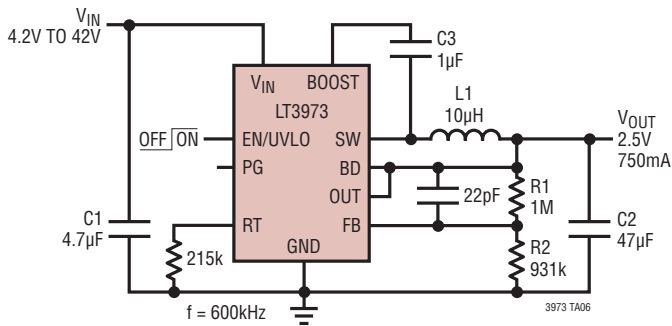

1.8V Step-Down Converter

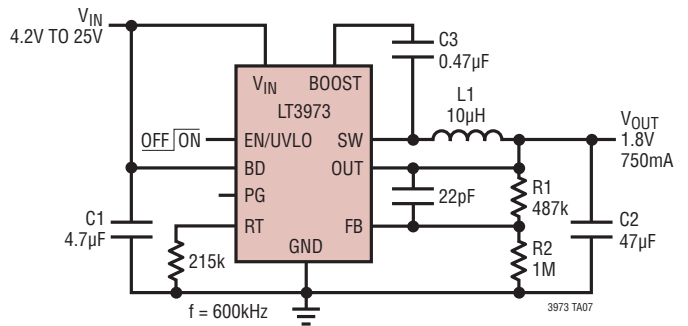

12V Step-Down Converter

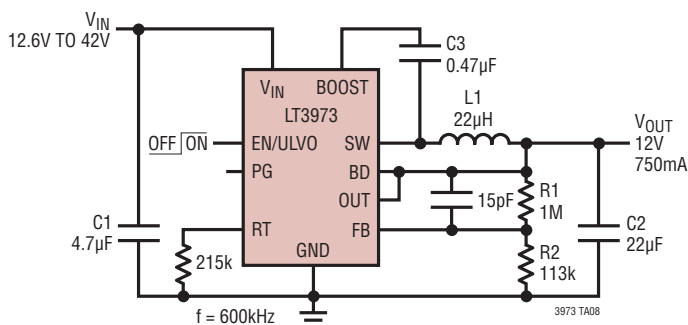

5V, 2MHz Step-Down Converter

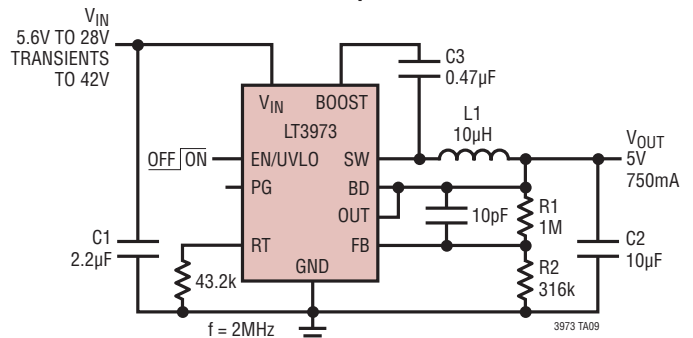

3973fb

TYPICAL APPLICATIONS

5V Step-Down Converter with Undervoltage Lockout

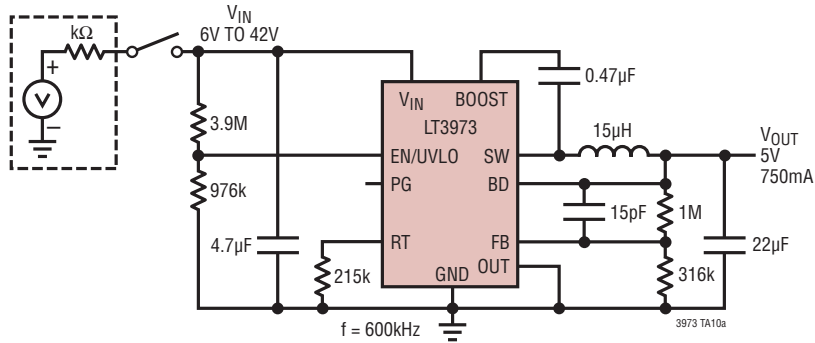

Input Current During Start-Up

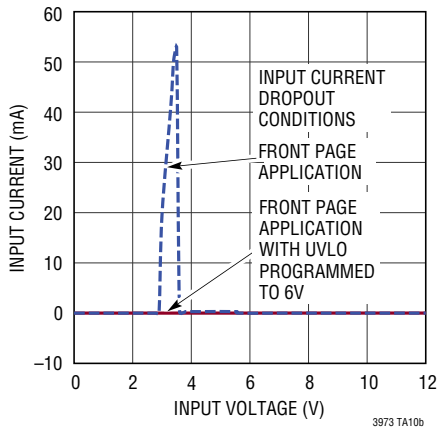

Start-Up from High Impedance Input Source

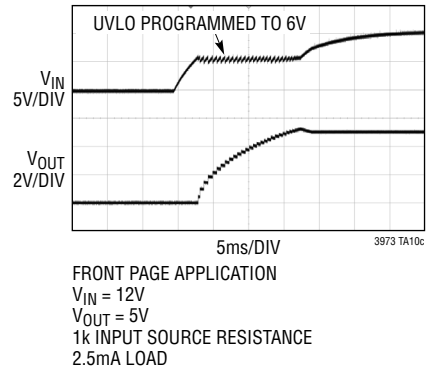

PACKAGE DESCRIPTION

Please refer to <http://www.linear.com/designtools/packaging/> for the most recent package drawings.

DD Package
10-Lead Plastic DFN (3mm × 3mm)
 (Reference LTC DWG # 05-08-1699 Rev C)

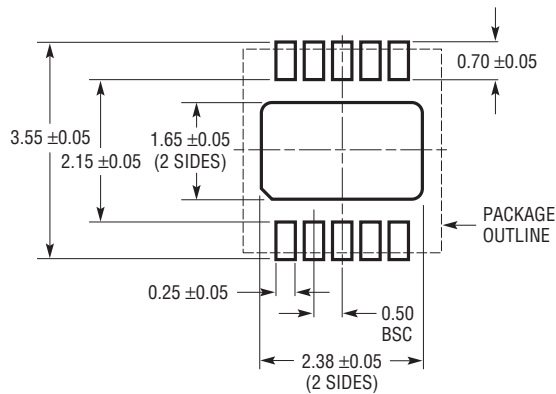

RECOMMENDED SOLDER PAD PITCH AND DIMENSIONS

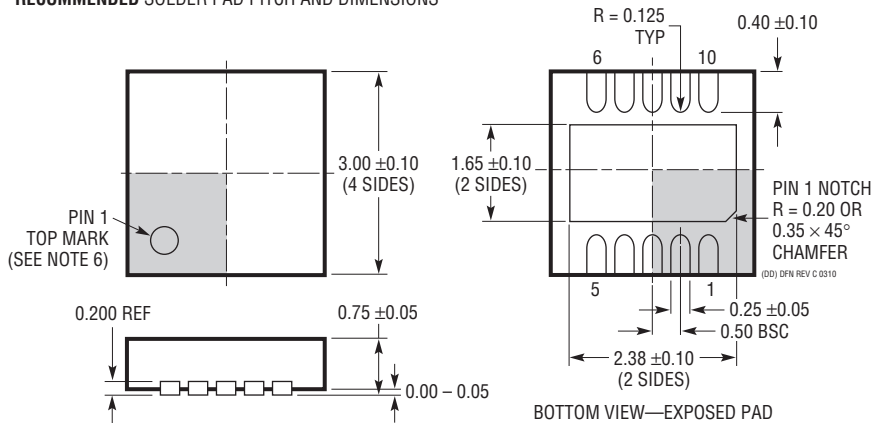

NOTE:

1. DRAWING TO BE MADE A JEDEC PACKAGE OUTLINE M0-229 VARIATION OF (WEED-2). CHECK THE LTC WEBSITE DATA SHEET FOR CURRENT STATUS OF VARIATION ASSIGNMENT
2. DRAWING NOT TO SCALE
3. ALL DIMENSIONS ARE IN MILLIMETERS
4. DIMENSIONS OF EXPOSED PAD ON BOTTOM OF PACKAGE DO NOT INCLUDE MOLD FLASH. MOLD FLASH, IF PRESENT, SHALL NOT EXCEED 0.15mm ON ANY SIDE
5. EXPOSED PAD SHALL BE SOLDER PLATED
6. SHADED AREA IS ONLY A REFERENCE FOR PIN 1 LOCATION ON THE TOP AND BOTTOM OF PACKAGE

PACKAGE DESCRIPTION

Please refer to <http://www.linear.com/designtools/packaging/> for the most recent package drawings.

MSE Package 10-Lead Plastic MSOP, Exposed Die Pad (Reference LTC DWG # 05-08-1664 Rev I)

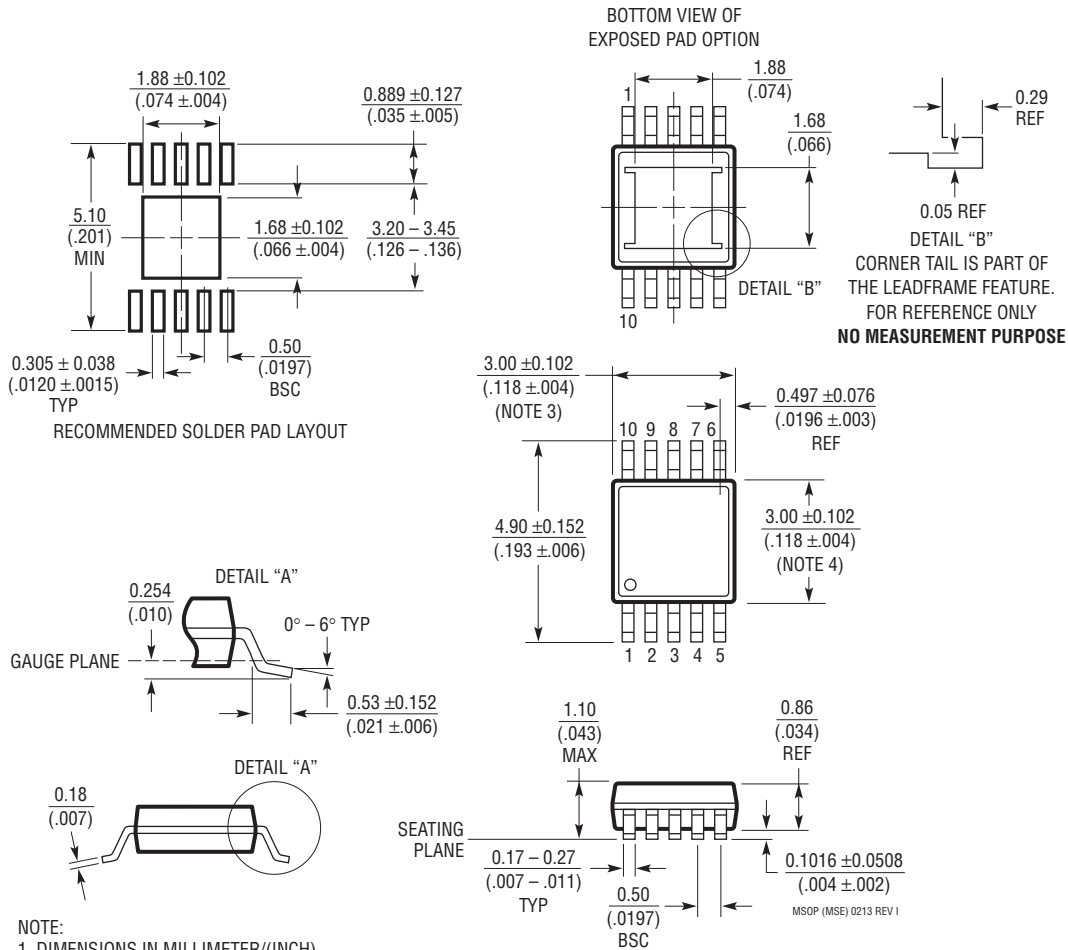

NOTE:

1. DIMENSIONS IN MILLIMETER/(INCH)
2. DRAWING NOT TO SCALE
3. DIMENSION DOES NOT INCLUDE MOLD FLASH, PROTRUSIONS OR GATE BURRS. MOLD FLASH, PROTRUSIONS OR GATE BURRS SHALL NOT EXCEED 0.152mm (.006") PER SIDE
4. DIMENSION DOES NOT INCLUDE INTERLEAD FLASH OR PROTRUSIONS. INTERLEAD FLASH OR PROTRUSIONS SHALL NOT EXCEED 0.152mm (.006") PER SIDE
5. LEAD COPLANARITY (BOTTOM OF LEADS AFTER FORMING) SHALL BE 0.102mm (.004") MAX
6. EXPOSED PAD DIMENSION DOES INCLUDE MOLD FLASH. MOLD FLASH ON E-PAD SHALL NOT EXCEED 0.254mm (.010") PER SIDE.

REVISION HISTORY

REV	DATE	DESCRIPTION	PAGE NUMBER
A	4/12	Title and Features modified to include fixed output versions.	1
		Absolute Maximum Ratings, Pin Configuration, and Order Information sections modified to include fixed output versions.	2
		Electrical Characteristics table modified to include fixed output versions.	3
		Graphs modified to include fixed output versions.	5
		Pin Functions and Block Diagram modified to include fixed output versions.	9, 10
		Applications for fixed output versions added.	19
B	3/15	Clarified package designator from MS to MSE – All	2
		Clarified Electrical Characteristics	3

TYPICAL APPLICATION

1.21V Step-Down Converter

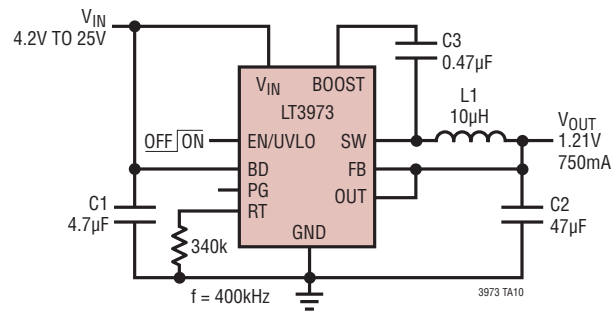

RELATED PARTS

PART NUMBER	DESCRIPTION	COMMENTS
LT3970/LT3970-3.3/LT3970-5	40V, 350mA, 2.2MHz High Efficiency Micropower Step-Down DC/DC Converter with $I_Q = 2.5\mu\text{A}$	$V_{IN} = 4.2\text{V to } 40\text{V}$, $V_{OUT(MIN)} = 1.21\text{V}$, $I_Q = 2.5\mu\text{A}$, $I_{SD} < 1\mu\text{A}$, 3mm × 2mm DFN-10, MSOP-10
LT3990	62V, 350mA, 2.2MHz High Efficiency Micropower Step-Down DC/DC Converter with $I_Q = 2.5\mu\text{A}$	$V_{IN} = 4.2\text{V to } 62\text{V}$, $V_{OUT(MIN)} = 1.21\text{V}$, $I_Q = 2.5\mu\text{A}$, $I_{SD} < 1\mu\text{A}$, 3mm × 3mm DFN-16, MSOP-16E
LT3971	38V, 1.2A, 2.2MHz High Efficiency Micropower Step-Down DC/DC Converter with $I_Q = 2.8\mu\text{A}$	$V_{IN} = 4.3\text{V to } 38\text{V}$, $V_{OUT(MIN)} = 1.2\text{V}$, $I_Q = 2.8\mu\text{A}$, $I_{SD} < 1\mu\text{A}$, 3mm × 3mm DFN-10, MSOPE-10
LT3991	55V, 1.2A, 2.2MHz High Efficiency Micropower Step-Down DC/DC Converter with $I_Q = 2.8\mu\text{A}$	$V_{IN} = 4.3\text{V to } 55\text{V}$, $V_{OUT(MIN)} = 1.2\text{V}$, $I_Q = 2.8\mu\text{A}$, $I_{SD} < 1\mu\text{A}$, 3mm × 3mm DFN-10, MSOPE-10
LT3682	36V, 60V _{MAX} , 1A, 2.2MHz High Efficiency Micropower Step-Down DC/DC Converter	$V_{IN} = 3.6\text{V to } 36\text{V}$, $V_{OUT(MIN)} = 0.8\text{V}$, $I_Q = 75\mu\text{A}$, $I_{SD} < 1\mu\text{A}$, 3mm × 3mm DFN-12

Looking for pricing, stock, or lifecycle information?

Click below to explore more details on WIN SOURCE:

 [View LT3973EDD#PBF on WIN SOURCE](#)

 [Linear Technology](#) Information

Optimize Your Supply Chain with WIN SOURCE Solutions

-  Global Sourcing Solution
-  Obsolete Management
-  Cost Control Management
-  Shortage Management
-  Alternative Solution
-  Excess Inventory Management