



**THE DATASHEET OF
LT3990IMSE-3.3#PBF**



FEATURES

- **Low Ripple Burst Mode® Operation**
 2.5µA I_Q at 12V_{IN} to 3.3V_{OUT}
 Output Ripple < 5mV_{P-P}
- **Wide Input Voltage Range: 4.2V to 62V Operating**
- **Adjustable Switching Frequency: 200kHz to 2.2MHz**
- **Integrated Boost and Catch Diodes**
- **350mA Output Current**
- **Fixed Output Voltages: 3.3V, 5V**
 2µA I_Q at 12V_{IN}
- **Accurate Programmable Undervoltage Lockout**
- **FMEA Fault Tolerant (MSOP Package)**
 Output Stays at or Below Regulation Voltage During
 Adjacent Pin Short or When a Pin is Left Floating
- **Low Shutdown Current: $I_Q = 0.7µA$**
- **Internal Sense Limits Catch Diode Current**
- **Power Good Flag**
- **Small, Thermally Enhanced 16-Pin MSOP
 and (3mm × 3mm) DFN Packages**

APPLICATIONS

- Automotive Battery Regulation
- Power for Portable Products
- Industrial Supplies

DESCRIPTION

The LT[®]3990 is an adjustable frequency monolithic buck switching regulator that accepts a wide input voltage range up to 62V, and consumes only 2.5µA of quiescent current. A high efficiency switch is included on the die along with the catch diode, boost diode, and the necessary oscillator, control and logic circuitry. Low ripple Burst Mode operation maintains high efficiency at low output currents while keeping the output ripple below 5mV in a typical application. Current mode topology is used for fast transient response and good loop stability. A catch diode current limit provides protection against shorted outputs and overvoltage conditions. An accurate programmable undervoltage lockout feature is available, producing a low shutdown current of 0.7µA. A power good flag signals when V_{OUT} reaches 90% of the programmed output voltage. The LT3990 is available in small, thermally enhanced 16-pin MSOP and 3mm × 3mm DFN packages.

LT, LT, LTC, LTM, Burst Mode, Linear Technology and the Linear logo are registered trademarks of Linear Technology Corporation. All other trademarks are the property of their respective owners.

TYPICAL APPLICATION

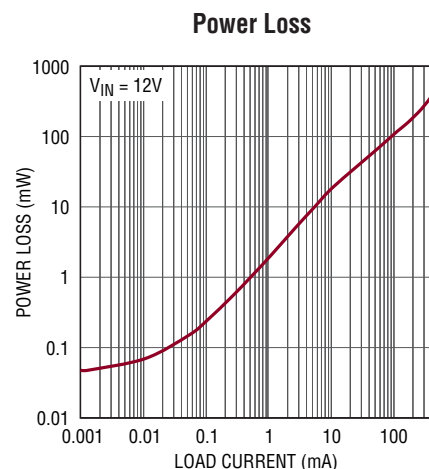
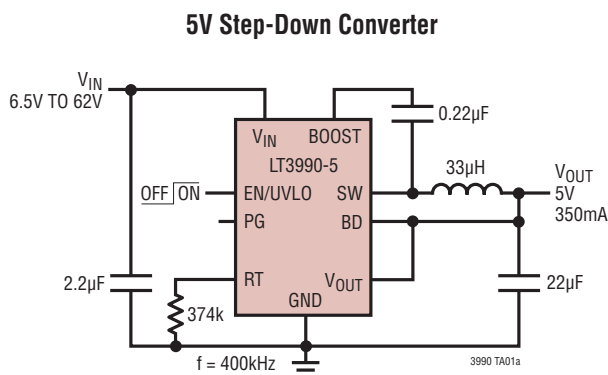

3990 TA01b

3990fa

LT3990/LT3990-3.3/LT3990-5

ABSOLUTE MAXIMUM RATINGS (Note 1)

V_{IN} , EN/UVLO Voltage	62V
BOOST Pin Voltage	75V
BOOST Pin Above SW Pin.....	30V
FB/ V_{OUT} , RT Voltage.....	6V
PG, BD Voltage	30V

Operating Junction Temperature Range (Note 2)	
LT3990E/LT3990E-X.....	-40°C to 125°C
LT3990I/LT3990I-X	-40°C to 125°C
LT3990H/LT3990H-X.....	-40°C to 150°C
Storage Temperature Range.....	-65°C to 150°C
Lead Temperature (Soldering, 10 sec)	
MS Only	300°C

PIN CONFIGURATION



ORDER INFORMATION

LEAD FREE FINISH	TAPE AND REEL	PART MARKING*	PACKAGE DESCRIPTION	TEMPERATURE RANGE
LT3990EDD#PBF	LT3990EDD#TRPBF	LFWJ	10-Lead (3mm × 3mm) Plastic DFN	-40°C to 125°C
LT3990IDD#PBF	LT3990IDD#TRPBF	LFWJ	10-Lead (3mm × 3mm) Plastic DFN	-40°C to 125°C
LT3990EMSE#PBF	LT3990EMSE#TRPBF	3990	16-Lead Plastic MSOP	-40°C to 125°C
LT3990IMSE#PBF	LT3990IMSE#TRPBF	3990	16-Lead Plastic MSOP	-40°C to 125°C
LT3990HMSE#PBF	LT3990HMSE#TRPBF	3990	16-Lead Plastic MSOP	-40°C to 150°C
LT3990EMSE-3.3#PBF	LT3990EMSE-3.3#TRPBF	399033	16-Lead Plastic MSOP	-40°C to 125°C
LT3990IMSE-3.3#PBF	LT3990IMSE-3.3#TRPBF	399033	16-Lead Plastic MSOP	-40°C to 125°C
LT3990HMSE-3.3#PBF	LT3990HMSE-3.3#TRPBF	399033	16-Lead Plastic MSOP	-40°C to 150°C
LT3990EMSE-5#PBF	LT3990EMSE-5#TRPBF	39905	16-Lead Plastic MSOP	-40°C to 125°C
LT3990IMSE-5#PBF	LT3990IMSE-5#TRPBF	39905	16-Lead Plastic MSOP	-40°C to 125°C
LT3990HMSE-5#PBF	LT3990HMSE-5#TRPBF	39905	16-Lead Plastic MSOP	-40°C to 150°C

Consult LTC Marketing for parts specified with wider operating temperature ranges. *The temperature grade is identified by a label on the shipping container. Consult LTC Marketing for information on non-standard lead based finish parts.

For more information on lead free part marking, go to: <http://www.linear.com/leadfree/>

For more information on tape and reel specifications, go to: <http://www.linear.com/tapeandree/>

ELECTRICAL CHARACTERISTICS

The ● denotes the specifications which apply over the full operating temperature range, otherwise specifications are at $T_A = 25^\circ\text{C}$. $V_{IN} = 12\text{V}$, $V_{BD} = 3.3\text{V}$ unless otherwise noted. (Note 2)

PARAMETER	CONDITIONS		MIN	TYP	MAX	UNITS
Minimum Input Voltage		●		4	4.2	V
Quiescent Current from V_{IN}	$V_{EN/UVLO}$ Low			0.7	1.2	μA
	$V_{EN/UVLO}$ High			1.9	2.8	μA
	$V_{EN/UVLO}$ High	●			4	μA
LT3990 Feedback Voltage			1.195	1.21	1.225	V
		●	1.185	1.21	1.235	V
LT3990-3.3 Output Voltage			3.26	3.3	3.34	V
		●	3.234	3.3	3.366	V
LT3990-5 Output Voltage			4.94	5	5.06	V
		●	4.9	5	5.1	V
LT3990 FB Pin Bias Current (Note 3)		●		0.1	20	nA
FB/Output Voltage Line Regulation	$4.2\text{V} < V_{IN} < 40\text{V}$			0.0002	0.01	%/V
Switching Frequency	$R_T = 41.2\text{k}$, $V_{IN} = 6\text{V}$		1.84	2.3	2.76	MHz
	$R_T = 158\text{k}$, $V_{IN} = 6\text{V}$		672	840	1008	kHz
	$R_T = 768\text{k}$, $V_{IN} = 6\text{V}$		168	210	252	kHz
Switch Current Limit	$V_{IN} = 5\text{V}$, $V_{FB} = 0\text{V}$		535	700	865	mA
Catch Schottky Current Limit	$V_{IN} = 5\text{V}$		360	450	540	mA
Switch V_{CESAT}	$I_{SW} = 200\text{mA}$			210		mV
Switch Leakage Current				0.05	2	μA
Catch Schottky Forward Voltage	$I_{SCH} = 100\text{mA}$, $V_{IN} = V_{BD} = \text{NC}$			725		mV
Catch Schottky Reverse Leakage	$V_{SW} = 12\text{V}$			0.05	2	μA
Boost Schottky Forward Voltage	$I_{SCH} = 50\text{mA}$, $V_{IN} = \text{NC}$, $V_{BOOST} = 0\text{V}$			900		mV
Boost Schottky Reverse Leakage	$V_{REVERSE} = 12\text{V}$			0.02	2	μA
Minimum Boost Voltage (Note 4)	$V_{IN} = 5\text{V}$	●		1.4	1.8	V
BOOST Pin Current	$I_{SW} = 200\text{mA}$, $V_{BOOST} = 15\text{V}$			8.5	12	mA
EN/UVLO Pin Current	$V_{EN/UVLO} = 12\text{V}$			1	30	nA
EN/UVLO Voltage Threshold	EN/UVLO Rising, $V_{IN} \geq 4.2\text{V}$	●	1.14	1.19	1.28	V
EN/UVLO Voltage Hysteresis				35		mV
PG Threshold Offset from Feedback Voltage	V_{FB} Rising		6.5	10	13.5	%
PG Hysteresis as % of Output Voltage				1.0		%
PG Leakage	$V_{PG} = 3\text{V}$			0.01	1	μA
PG Sink Current	$V_{PG} = 0.4\text{V}$	●	30	80		μA
Minimum Switch On-Time				115		ns
Minimum Switch Off-Time	$V_{IN} = 10\text{V}$	●		100	160	ns

Note 1: Stresses beyond those listed under Absolute Maximum Ratings may cause permanent damage to the device. Exposure to any Absolute Maximum Rating condition for extended periods may affect device reliability and lifetime.

Note 2: The LT3990E is guaranteed to meet performance specifications from 0°C to 125°C junction temperature. Specifications over the -40°C to 125°C operating junction temperature range are assured by design, characterization, and correlation with statistical process controls. The LT3990I is guaranteed over the full -40°C to 125°C operating junction temperature range. The LT3990H is guaranteed over the full -40°C to 150°C operating junction temperature range. High junction temperatures degrade operating lifetimes. Operating lifetime is derated at junction temperatures greater than 125°C .

Note 3: Bias current flows into the FB pin.

Note 4: This is the minimum voltage across the boost capacitor needed to guarantee full saturation of the switch.

TYPICAL PERFORMANCE CHARACTERISTICS $T_A = 25^\circ\text{C}$, unless otherwise noted.

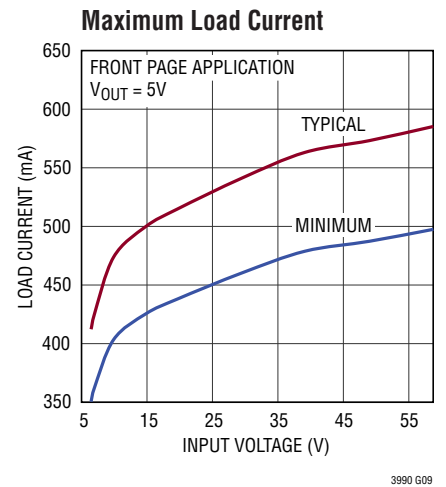
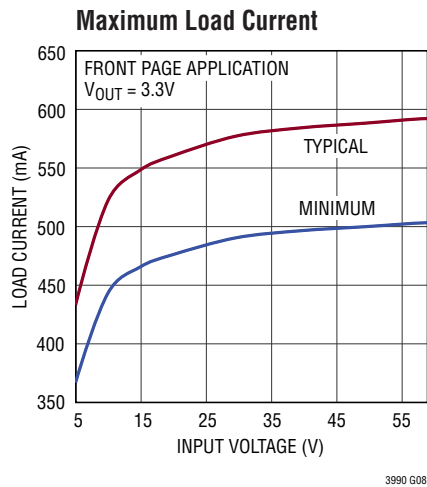
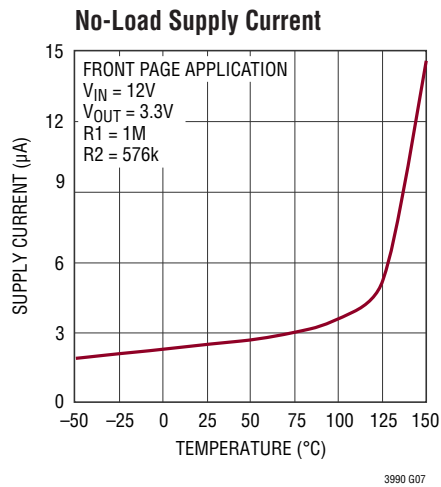
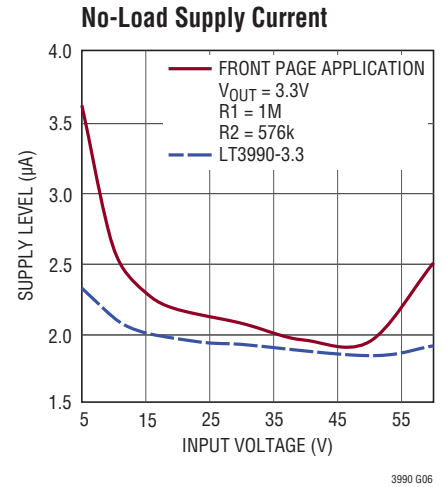
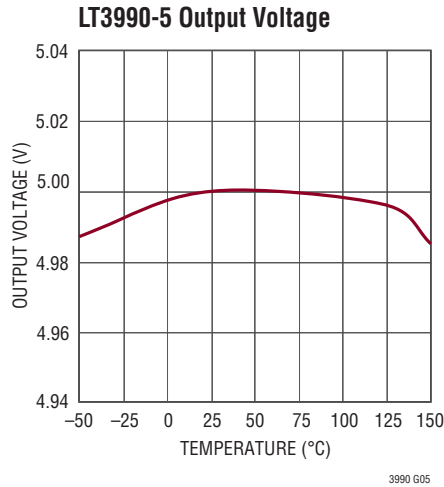
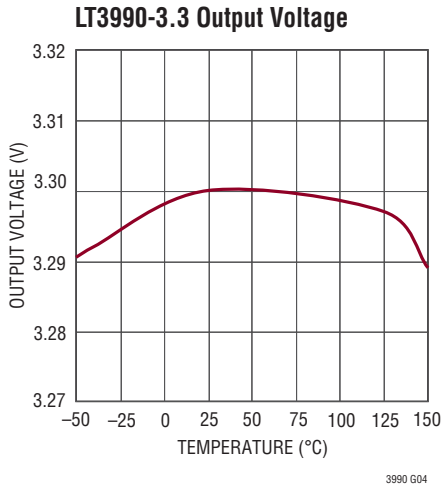
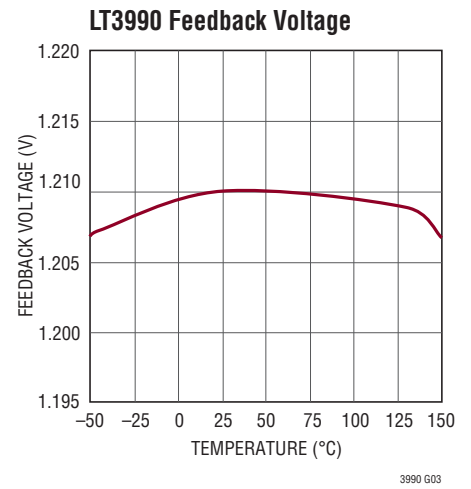
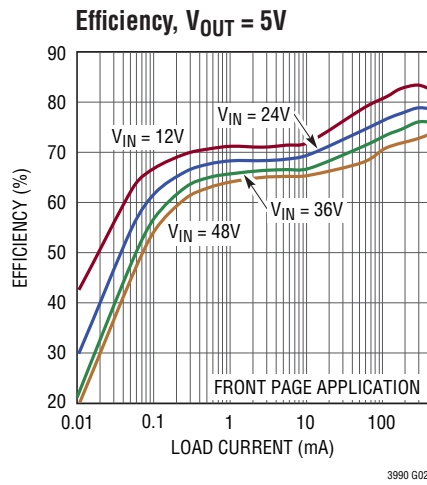
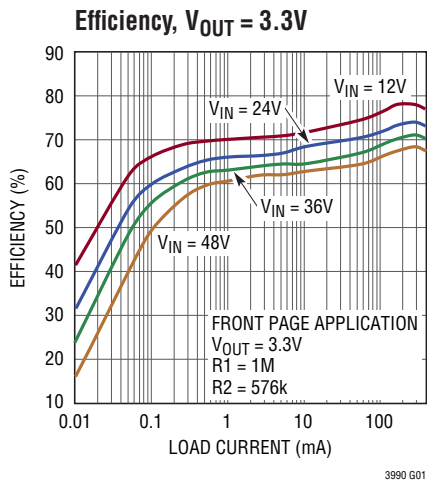

TYPICAL PERFORMANCE CHARACTERISTICS $T_A = 25^\circ\text{C}$, unless otherwise noted.

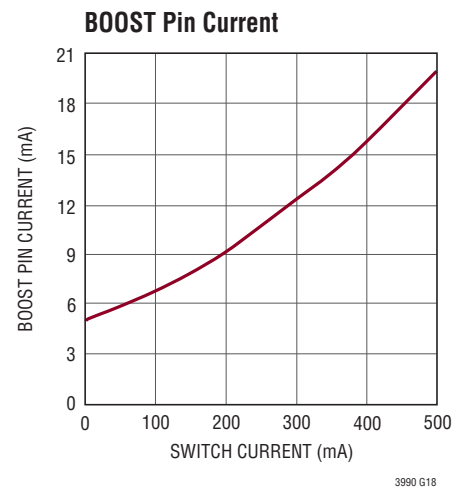
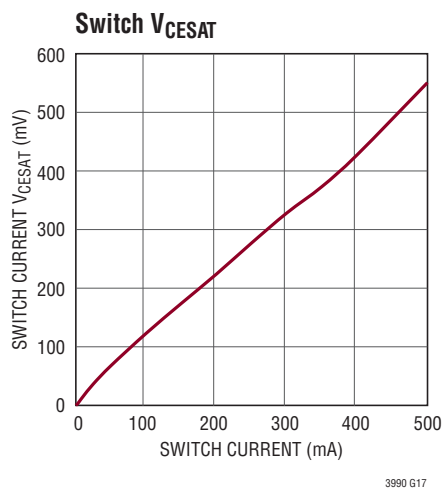
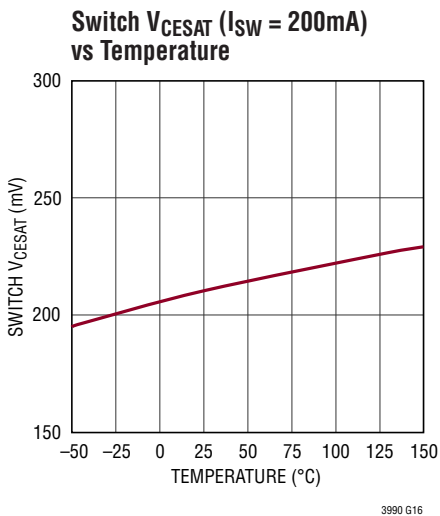
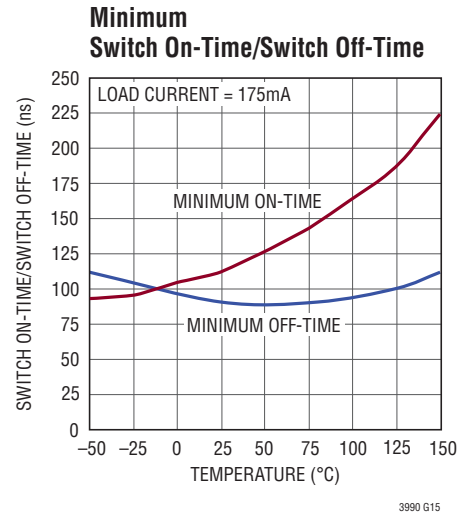
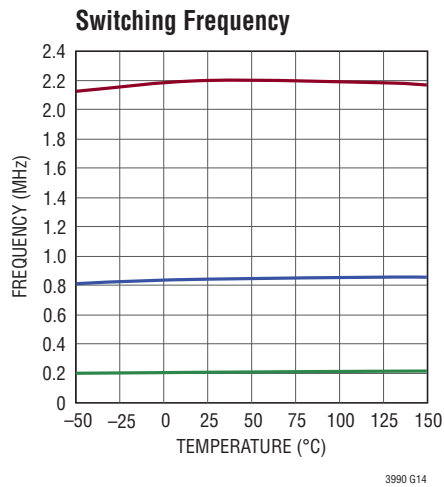
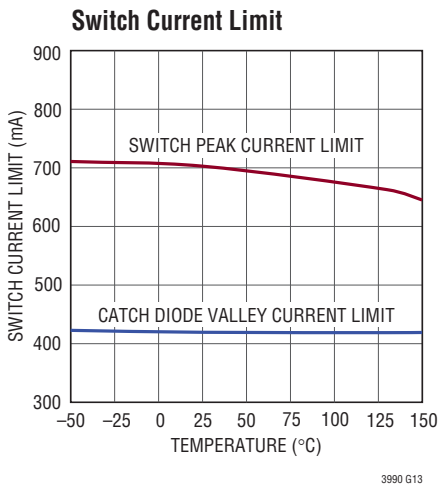
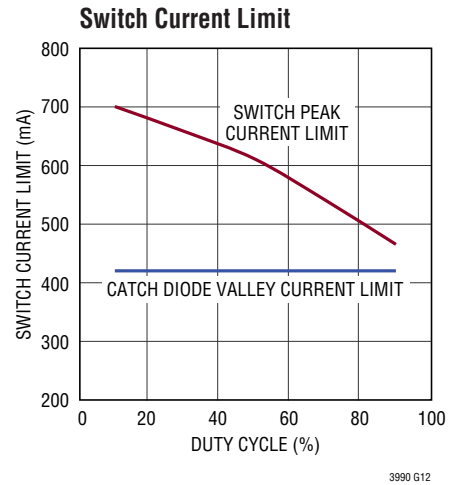
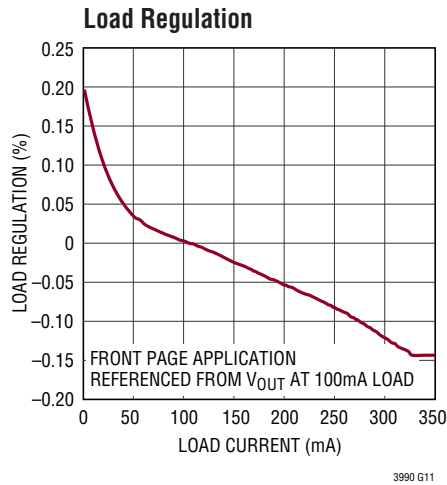
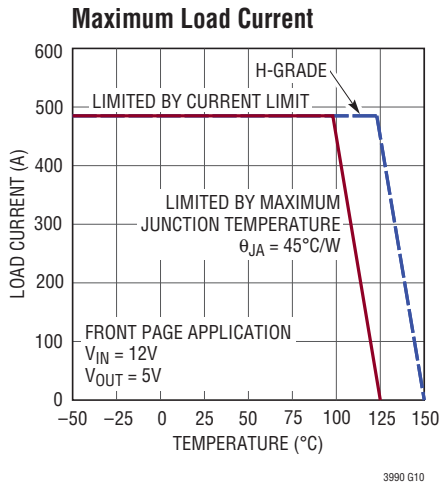

TYPICAL PERFORMANCE CHARACTERISTICS $T_A = 25^\circ\text{C}$, unless otherwise noted.

Minimum Input Voltage, $V_{OUT} = 3.3\text{V}$

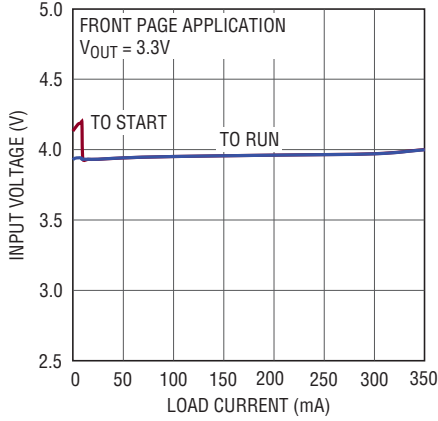

Minimum Input Voltage, $V_{OUT} = 5\text{V}$

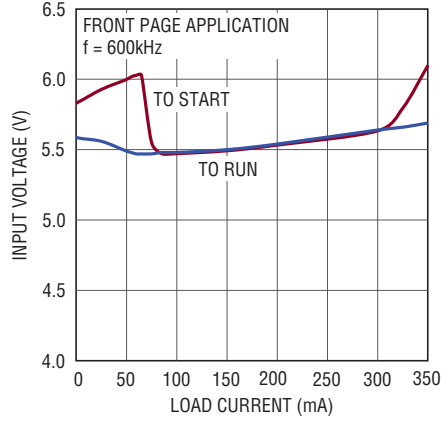

Boost Diode Forward Voltage

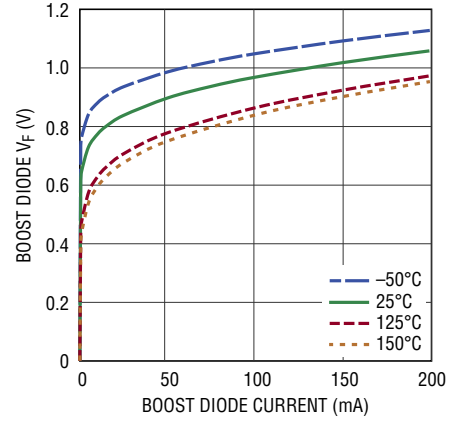

Catch Diode Forward Voltage

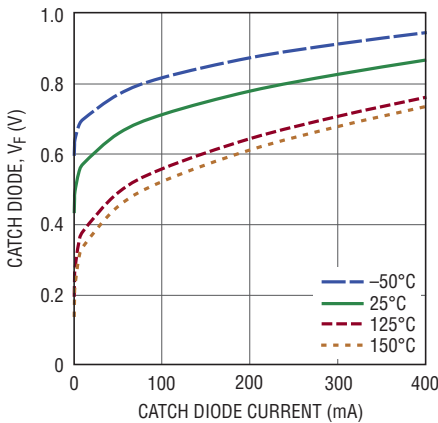

Catch Diode Leakage

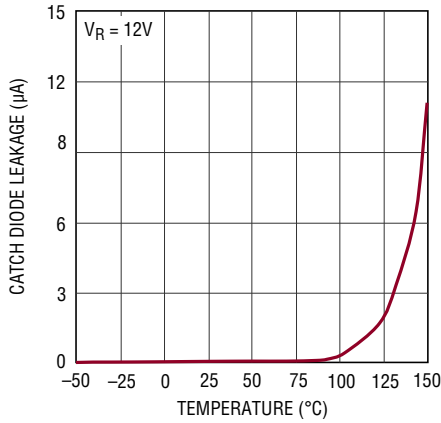

Power Good Threshold

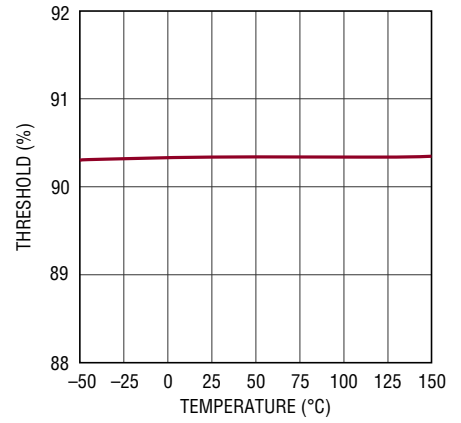

EN/UVLO Threshold

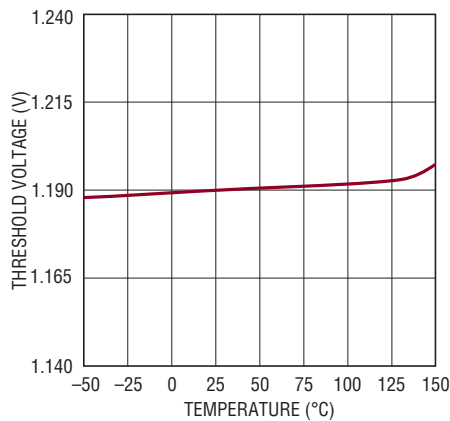

Transient Load Response; Load Current is Stepped from 10mA (Burst Mode Operation) to 110mA

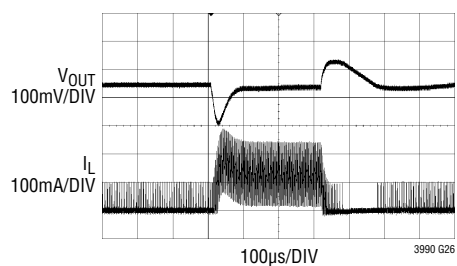

FRONT PAGE APPLICATION
 $V_{IN} = 12\text{V}$
 $V_{OUT} = 5\text{V}$

Transient Load Response; Load Current is Stepped from 100mA to 200mA

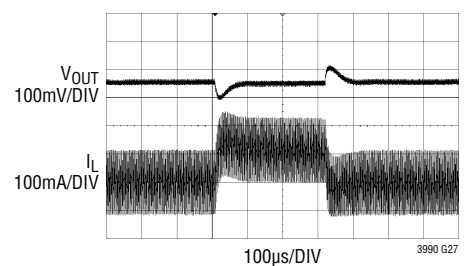

FRONT PAGE APPLICATION
 $V_{IN} = 12\text{V}$
 $V_{OUT} = 5\text{V}$

TYPICAL PERFORMANCE CHARACTERISTICS $T_A = 25^\circ\text{C}$, unless otherwise noted.

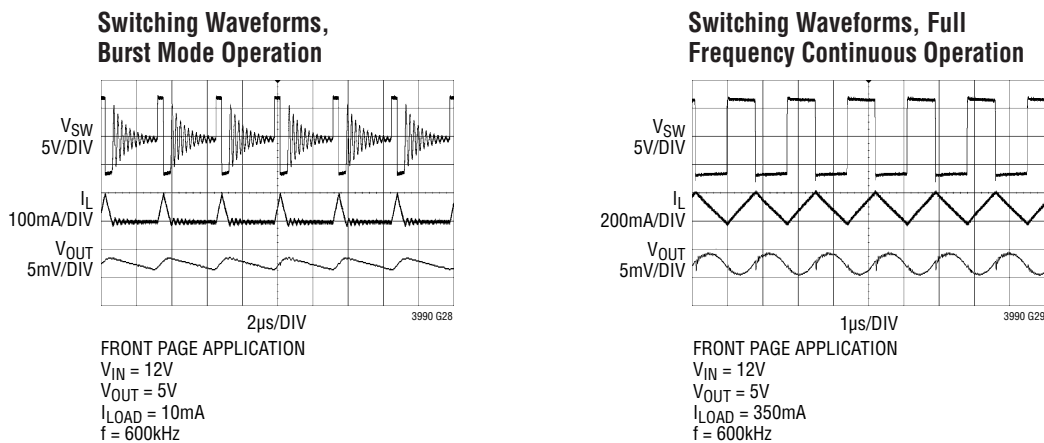

PIN FUNCTIONS (DFN, MSOP)

FB (Pin 1/Pins 1, 2 LT3990 Only): The LT3990 regulates the FB pin to 1.21V. Connect the feedback resistor divider tap to this pin. The two FB pins on the MSE package are connected internally and provide a redundant path for the feedback divider. Tie the divider to both pins.

V_{OUT} (Pins 1, 2, LT3990-X Only): The LT3990-3.3 and LT3990-5 regulate the V_{OUT} pin to 3.3V and 5V, respectively. This pin connects to the internal feedback divider that programs the fixed output voltage. The two V_{OUT} pins are connected internally and provide a redundant path to the output. Tie the output to both pins.

EN/UVLO (Pin 2/Pin 4): The part is in shutdown when this pin is low and active when this pin is high. The threshold voltage is 1.19V going up with 35mV of hysteresis. Tie to V_{IN} if shutdown feature is not used. The EN/UVLO threshold is accurate only when V_{IN} is above 4.2V. If V_{IN} is lower than 4.2V, ground EN/UVLO to place the part in shutdown.

V_{IN} (Pin 3/Pin 6): The V_{IN} pin supplies current to the LT3990's internal circuitry and to the internal power switch. This pin must be locally bypassed.

GND (Pins 4, 5, Exposed Pad Pin 11/Pin 8, Exposed Pad Pin 17): Ground. The exposed pad must be soldered to the PCB.

SW (Pin 6/Pin 9): The SW pin is the output of an internal power switch. Connect this pin to the inductor.

BOOST (Pin 7/Pin 11): This pin is used to provide a drive voltage, higher than the input voltage, to the internal bipolar NPN power switch.

BD (Pin 8/Pin 13): This pin connects to the anode of the boost diode. This pin also supplies current to the LT3990's internal regulator when BD is above 3.2V.

PG (Pin 9/Pin 14): The PG pin is the open-drain output of an internal comparator. PG remains low until the FB pin is within 10% of the final regulation voltage. PG is valid when V_{IN} is above 4.2V and EN/UVLO is high.

RT (Pin 10/Pin 16): A resistor is tied between RT and ground to set the switching frequency.

NC (Pins 3, 5, 7, 10, 12, 15, MSOP Only): No Connects. These pins are not connected to internal circuitry and must be left floating to ensure fault tolerance.

BLOCK DIAGRAM

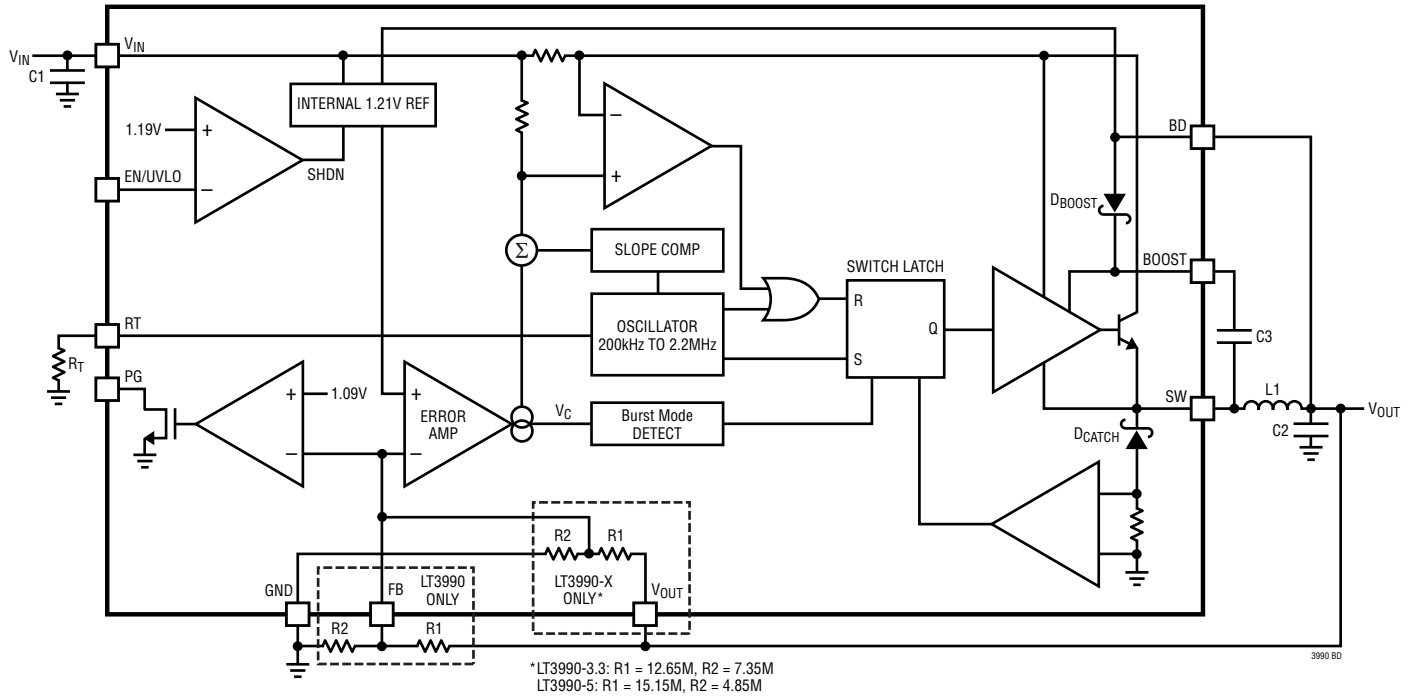

OPERATION

The LT3990 is a constant frequency, current mode step-down regulator. An oscillator, with frequency set by R_T , sets an RS flip-flop, turning on the internal power switch. An amplifier and comparator monitor the current flowing between the V_{IN} and SW pins, turning the switch off when this current reaches a level determined by the voltage at V_C (see Block Diagram). An error amplifier measures the output voltage through an external resistor divider tied to the FB pin and servos the V_C node. If the error amplifier's output increases, more current is delivered to the output; if it decreases, less current is delivered.

Another comparator monitors the current flowing through the catch diode and reduces the operating frequency when the current exceeds the 450mA bottom current limit. This foldback in frequency helps to control the output current in fault conditions such as a shorted output with high input voltage. Maximum deliverable current to the output is therefore limited by both switch current limit and catch diode current limit.

An internal regulator provides power to the control circuitry. The bias regulator normally draws power from the V_{IN} pin, but if the BD pin is connected to an external voltage higher than 3.2V, bias power will be drawn from the external source (typically the regulated output voltage). This improves efficiency.

If the EN/UVLO pin is low, the LT3990 is shut down and draws 0.7 μ A from the input. When the EN/UVLO pin exceeds 1.19V, the switching regulator will become active.

The switch driver operates from either V_{IN} or from the BOOST pin. An external capacitor is used to generate a voltage at the BOOST pin that is higher than the input supply. This allows the driver to fully saturate the internal bipolar NPN power switch for efficient operation.

To further optimize efficiency, the LT3990 automatically switches to Burst Mode operation in light load situations. Between bursts, all circuitry associated with controlling the output switch is shut down reducing the input supply current to 1.8 μ A.

The LT3990 contains a power good comparator which trips when the FB pin is at 90% of its regulated value. The PG output is an open-drain transistor that is off when the output is in regulation, allowing an external resistor to pull the PG pin high. Power good is valid when the LT3990 is enabled and V_{IN} is above 4.2V.

APPLICATIONS INFORMATION

FB Resistor Network

The output voltage is programmed with a resistor divider between the output and the FB pin. Choose the 1% resistors according to:

$$R1 = R2 \left(\frac{V_{OUT}}{1.21} - 1 \right)$$

Reference designators refer to the Block Diagram. Note that choosing larger resistors will decrease the quiescent current of the application circuit.

Setting the Switching Frequency

The LT3990 uses a constant frequency PWM architecture that can be programmed to switch from 200kHz to 2.2MHz by using a resistor tied from the RT pin to ground. A table showing the necessary R_T value for a desired switching frequency is in Table 1.

Table 1. Switching Frequency vs R_T Value

SWITCHING FREQUENCY (MHz)	R_T VALUE (k Ω)
0.2	787
0.3	511
0.4	374
0.5	287
0.6	232
0.8	169
1.0	127
1.2	102
1.4	84.5
1.6	69.8
1.8	59
2.0	51.1
2.2	44.2

Operating Frequency Trade-Offs

Selection of the operating frequency is a trade-off between efficiency, component size, minimum dropout voltage and maximum input voltage. The advantage of high frequency operation is that smaller inductor and capacitor values may be used. The disadvantages are lower efficiency, lower maximum input voltage, and higher dropout voltage. The highest acceptable switching frequency ($f_{SW(MAX)}$) for a given application can be calculated as follows:

$$f_{SW(MAX)} = \frac{V_{OUT} + V_D}{t_{ON(MIN)} (V_{IN} - V_{SW} + V_D)}$$

where V_{IN} is the typical input voltage, V_{OUT} is the output voltage, V_D is the integrated catch diode drop (~0.7V), and V_{SW} is the internal switch drop (~0.5V at max load). This equation shows that slower switching frequency is necessary to accommodate high V_{IN}/V_{OUT} ratio.

Lower frequency also allows a lower dropout voltage. The input voltage range depends on the switching frequency because the LT3990 switch has finite minimum on and off times. The switch can turn off for a minimum of ~160ns but the minimum on-time is a strong function of temperature. Use the minimum switch on-time curve (see Typical Performance Characteristics) to design for an application's maximum temperature, while adding about 30% for part-to-part variation. The minimum and maximum duty cycles that can be achieved taking these on and off times into account are:

$$DC_{MIN} = f_{SW} \cdot t_{ON(MIN)}$$

$$DC_{MAX} = 1 - f_{SW} \cdot t_{OFF(MIN)}$$

where f_{SW} is the switching frequency, the $t_{ON(MIN)}$ is the minimum switch on-time, and the $t_{OFF(MIN)}$ is the minimum switch off-time (~160ns). These equations show that duty cycle range increases when switching frequency is decreased.

A good choice of switching frequency should allow adequate input voltage range (see next section) and keep the inductor and capacitor values small.

Input Voltage Range

The minimum input voltage is determined by either the LT3990's minimum operating voltage of 4.2V or by its maximum duty cycle (as explained in previous section). The minimum input voltage due to duty cycle is:

$$V_{IN(MIN)} = \frac{V_{OUT} + V_D}{1 - f_{SW} \cdot t_{OFF(MIN)}} - V_D + V_{SW}$$

where $V_{IN(MIN)}$ is the minimum input voltage, V_{OUT} is the output voltage, V_D is the catch diode drop (~0.7V), V_{SW} is the internal switch drop (~0.5V at max load), f_{SW} is the switching frequency (set by R_T), and $t_{OFF(MIN)}$ is the minimum switch off-time (160ns). Note that higher switching frequency will increase the minimum input voltage.

APPLICATIONS INFORMATION

If a lower dropout voltage is desired, a lower switching frequency should be used.

The highest allowed V_{IN} during normal operation ($V_{IN(OP-MAX)}$) is limited by minimum duty cycle and can be calculated by the following equation:

$$V_{IN(OP-MAX)} = \frac{V_{OUT} + V_D}{f_{SW} \cdot t_{ON(MIN)}} - V_D + V_{SW}$$

where $t_{ON(MIN)}$ is the minimum switch on-time.

However, the circuit will tolerate inputs up to the absolute maximum ratings of the V_{IN} and BOOST pins, regardless of chosen switching frequency. During such transients where V_{IN} is higher than $V_{IN(OP-MAX)}$, the switching frequency will be reduced below the programmed frequency to prevent damage to the part. The output voltage ripple and inductor current ripple may also be higher than in typical operation, however the output will still be in regulation.

Inductor Selection

For a given input and output voltage, the inductor value and switching frequency will determine the ripple current. The ripple current increases with higher V_{IN} or V_{OUT} and decreases with higher inductance and faster switching frequency. A good starting point for selecting the inductor value is:

$$L = 3 \frac{V_{OUT} + V_D}{f_{SW}}$$

Table 2. Inductor Vendors

VENDOR	URL
Coilcraft	www.coilcraft.com
Sumida	www.sumida.com
Toko	www.tokoam.com
Würth Elektronik	www.we-online.com
Coiltronics	www.cooperet.com
Murata	www.murata.com

where V_D is the voltage drop of the catch diode (~0.7V), L is in μH and f_{SW} is in MHz. The inductor's RMS current rating must be greater than the maximum load current and its saturation current should be about 30% higher. For robust operation in fault conditions (start-up or short circuit) and high input voltage (>30V), the saturation current should be above 800mA. To keep the efficiency high, the series resistance (DCR) should be less than 0.1Ω , and the core material should be intended for high frequency applications. Table 2 lists several vendors and suitable types.

This simple design guide will not always result in the optimum inductor selection for a given application. As a general rule, lower output voltages and higher switching frequency will require smaller inductor values. If the application requires less than 350mA load current, then a lesser inductor value may be acceptable. This allows use of a physically smaller inductor, or one with a lower DCR resulting in higher efficiency. There are several graphs in the Typical Performance Characteristics section of this data sheet that show the maximum load current as a function of input voltage for several popular output voltages. Low inductance may result in discontinuous mode operation, which is acceptable but reduces maximum load current. For details of maximum output current and discontinuous mode operation, see Linear Technology Application Note 44. Finally, for duty cycles greater than 50% ($V_{OUT}/V_{IN} > 0.5$), there is a minimum inductance required to avoid subharmonic oscillations. See Application Note 19.

Input Capacitor

Bypass the input of the LT3990 circuit with a ceramic capacitor of X7R or X5R type. Y5V types have poor performance over temperature and applied voltage, and should not be used. A $1\mu\text{F}$ to $4.7\mu\text{F}$ ceramic capacitor is adequate to bypass the LT3990 and will easily handle the ripple current. Note that larger input capacitance is required when a lower switching frequency is used

APPLICATIONS INFORMATION

(due to longer on-times). If the input power source has high impedance, or there is significant inductance due to long wires or cables, additional bulk capacitance may be necessary. This can be provided with a low performance electrolytic capacitor.

Step-down regulators draw current from the input supply in pulses with very fast rise and fall times. The input capacitor is required to reduce the resulting voltage ripple at the LT3990 and to force this very high frequency switching current into a tight local loop, minimizing EMI. A 1µF capacitor is capable of this task, but only if it is placed close to the LT3990 (see the PCB Layout section). A second precaution regarding the ceramic input capacitor concerns the maximum input voltage rating of the LT3990. A ceramic input capacitor combined with trace or cable inductance forms a high quality (under damped) tank circuit. If the LT3990 circuit is plugged into a live supply, the input voltage can ring to twice its nominal value, possibly exceeding the LT3990's voltage rating. This situation is easily avoided (see the Hot Plugging Safely section).

Output Capacitor and Output Ripple

The output capacitor has two essential functions. It stores energy in order to satisfy transient loads and stabilize the LT3990's control loop. Ceramic capacitors have very low equivalent series resistance (ESR) and provide the best ripple performance. A good starting value is:

$$C_{OUT} = \frac{50}{V_{OUT} \cdot f_{SW}}$$

where f_{SW} is in MHz and C_{OUT} is the recommended output capacitance in µF. Use X5R or X7R types. This choice will provide low output ripple and good transient response. Transient performance can be improved with a higher value capacitor if combined with a phase lead capacitor (typically 22pF) between the output and the feedback pin. A lower value of output capacitor can be used to save space and cost but transient performance will suffer.

The second function is that the output capacitor, along with the inductor, filters the square wave generated by the LT3990 to produce the DC output. In this role it determines

the output ripple, so low impedance (at the switching frequency) is important. The output ripple decreases with increasing output capacitance, down to approximately 1mV. See Figure 1. Note that a larger phase lead capacitor should be used with a large output capacitor.

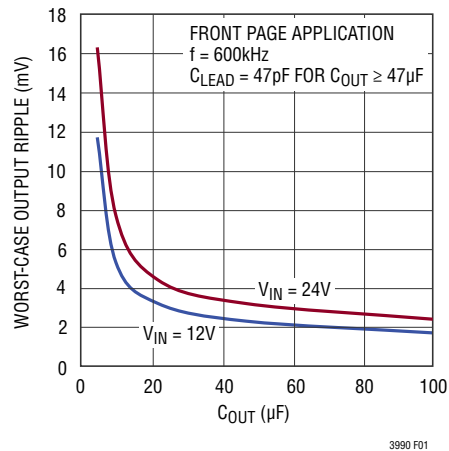

Figure 1. Worst-Case Output Ripple Across Full Load Range

When choosing a capacitor, look carefully through the data sheet to find out what the actual capacitance is under operating conditions (applied voltage and temperature). A physically larger capacitor or one with a higher voltage rating may be required. Table 3 lists several capacitor vendors.

Table 3. Recommended Ceramic Capacitor Vendors

MANUFACTURER	WEBSITE
AVX	www.avxcorp.com
Murata	www.murata.com
Taiyo Yuden	www.t-yuden.com
Vishay Siliconix	www.vishay.com
TDK	www.tdk.com

Ceramic Capacitors

Ceramic capacitors are small, robust and have very low ESR. However, ceramic capacitors can cause problems when used with the LT3990 due to their piezoelectric nature. When in Burst Mode operation, the LT3990's switching frequency depends on the load current, and at very light loads the LT3990 can excite the ceramic capacitor at audio frequencies, generating audible noise. Since the LT3990

APPLICATIONS INFORMATION

operates at a lower current limit during Burst Mode operation, the noise is typically very quiet to a casual ear. If this is unacceptable, use a high performance tantalum or electrolytic capacitor at the output.

A final precaution regarding ceramic capacitors concerns the maximum input voltage rating of the LT3990. As previously mentioned, a ceramic input capacitor combined with trace or cable inductance forms a high quality (under damped) tank circuit. If the LT3990 circuit is plugged into a live supply, the input voltage can ring to twice its nominal value, possibly exceeding the LT3990's rating. This situation is easily avoided (see the Hot Plugging Safely section).

Low Ripple Burst Mode Operation

To enhance efficiency at light loads, the LT3990 operates in low ripple Burst Mode operation which keeps the output capacitor charged to the proper voltage while minimizing the input quiescent current. During Burst Mode operation, the LT3990 delivers single cycle bursts of current to the output capacitor followed by sleep periods where the output power is delivered to the load by the output capacitor. Because the LT3990 delivers power to the output with single, low current pulses, the output ripple is kept below 5mV for a typical application. See Figure 2.

As the load current decreases towards a no load condition, the percentage of time that the LT3990 operates in sleep mode increases and the average input current is greatly reduced resulting in high efficiency even at very low loads. Note that during Burst Mode operation, the switching frequency will be lower than the programmed switching frequency. See Figure 3.

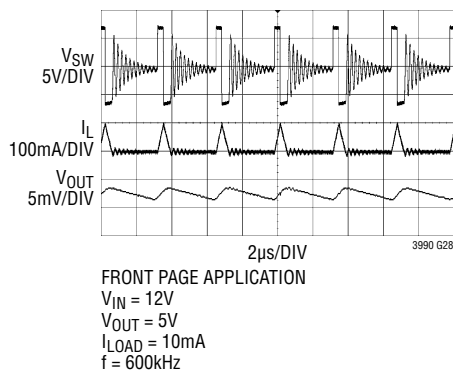

Figure 2. Burst Mode Operation

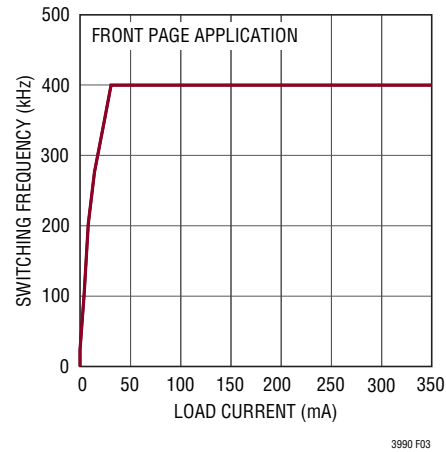

Figure 3. Switching Frequency in Burst Mode Operation

At higher output loads (above ~35mA for the front page application) the LT3990 will be running at the frequency programmed by the R_T resistor, and will be operating in standard PWM mode. The transition between PWM and low ripple Burst Mode is seamless, and will not disturb the output voltage.

BOOST and BD Pin Considerations

Capacitor C3 and the internal boost Schottky diode (see the Block Diagram) are used to generate a boost voltage that is higher than the input voltage. In most cases a 0.22µF capacitor will work well. Figure 4 shows two ways to arrange the boost circuit. The BOOST pin must be more than 1.9V above the SW pin for best efficiency. For outputs of 2.2V and above, the standard circuit (Figure 4a) is best. For outputs between 2.2V and 2.5V, use a 0.47µF boost capacitor. For output voltages below 2.2V, the boost diode can be tied to the input (Figure 4b), or to another external supply greater than 2.2V. However, the circuit in Figure 4a is more efficient because the BOOST pin current and BD pin quiescent current come from a lower voltage source. Also, be sure that the maximum voltage ratings of the BOOST and BD pins are not exceeded.

The minimum operating voltage of an LT3990 application is limited by the minimum input voltage (4.2V) and by the maximum duty cycle as outlined in a previous section. For proper start-up, the minimum input voltage is also limited by the boost circuit. If the input voltage is ramped slowly, the boost capacitor may not be fully charged. Because

APPLICATIONS INFORMATION

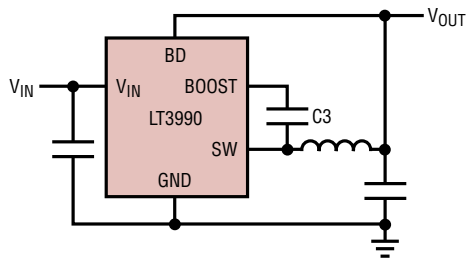

(4a) For $V_{OUT} \geq 2.2V$

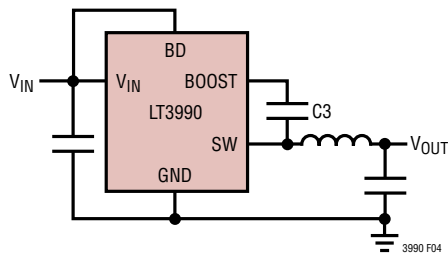

(4b) For $V_{OUT} < 2.2V$; $V_{IN} < 30V$

Figure 4. Two Circuits for Generating the Boost Voltage

the boost capacitor is charged with the energy stored in the inductor, the circuit will rely on some minimum load current to get the boost circuit running properly. This minimum load will depend on input and output voltages, and on the arrangement of the boost circuit. The minimum load generally goes to zero once the circuit has started. Figure 5 shows a plot of minimum load to start and to run as a function of input voltage. In many cases the discharged output capacitor will present a load to the switcher, which will allow it to start. The plots show the worst-case situation where V_{IN} is ramping very slowly. For lower start-up voltage, the boost diode can be tied to V_{IN} ; however, this restricts the input range to one-half of the absolute maximum rating of the BOOST pin.

Enable and Undervoltage Lockout

The LT3990 is in shutdown when the EN/UVLO pin is low and active when the pin is high. The rising threshold of the EN/UVLO comparator is 1.19V, with a 35mV hysteresis. This threshold is accurate when V_{IN} is above 4.2V. If V_{IN} is lower than 4.2V, tie EN/UVLO pin to GND to place the part in shutdown.

Figure 6 shows how to add undervoltage lockout (UVLO) to the LT3990. Typically, UVLO is used in situations where the input supply is current limited, or has a relatively high

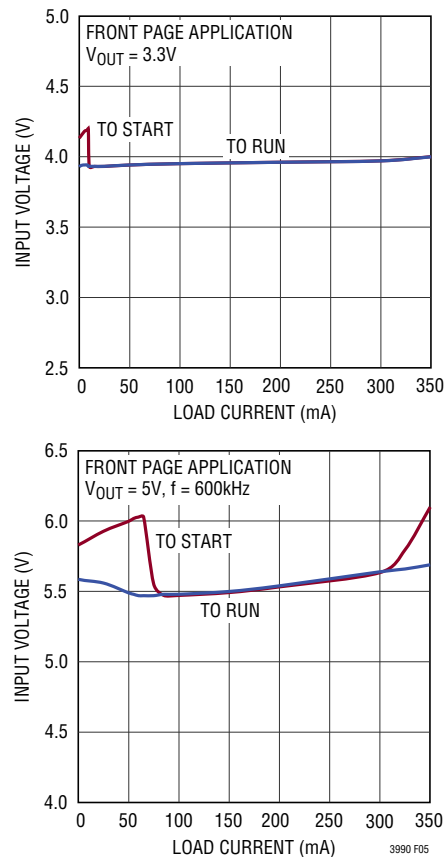

Figure 5. The Minimum Input Voltage Depends on Output Voltage, Load Current and Boost Circuit

source resistance. A switching regulator draws constant power from the source, so source current increases as source voltage drops. This looks like a negative resistance load to the source and can cause the source to current limit or latch low under low source voltage conditions. UVLO prevents the regulator from operating at source voltages where the problems might occur. The UVLO threshold can be adjusted by setting the values $R3$ and $R4$ such that they satisfy the following equation:

$$V_{UVLO} = \frac{R3+R4}{R4} \cdot 1.19V$$

where switching should not start until V_{IN} is above V_{UVLO} . Note that due to the comparator's hysteresis, switching will not stop until the input falls slightly below V_{UVLO} . Undervoltage lockout is functional only when V_{UVLO} is greater than 5V.

APPLICATIONS INFORMATION

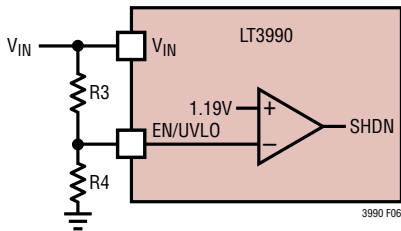

Figure 6. Undervoltage Lockout

Shorted and Reversed Input Protection

If the inductor is chosen so that it won't saturate excessively, a LT3990 buck regulator will tolerate a shorted output. There is another situation to consider in systems where the output will be held high when the input to the LT3990 is absent. This may occur in battery charging applications or in battery backup systems where a battery or some other supply is diode ORed with the LT3990's output. If the V_{IN} pin is allowed to float and the EN/UVLO pin is held high (either by a logic signal or because it is tied to V_{IN}), then the LT3990's internal circuitry will pull its quiescent current through its SW pin. This is fine if the system can tolerate a few μA in this state. If the EN/UVLO pin is grounded, the SW pin current will drop to $0.7\mu\text{A}$. However, if the V_{IN} pin is grounded while the output is held high, regardless of EN/UVLO, parasitic diodes inside the LT3990 can pull current from the output through the SW pin and the V_{IN} pin. Figure 7 shows a circuit that will run only when the input voltage is present and that protects against a shorted or reversed input.

PCB Layout

For proper operation and minimum EMI, care must be taken during printed circuit board layout. Figure 8 shows the recommended component placement with trace, ground plane and via locations. Note that large, switched currents flow in the LT3990's V_{IN} and SW pins, the internal catch diode and the input capacitor. The loop formed by these components should be as small as possible. These components, along with the inductor and

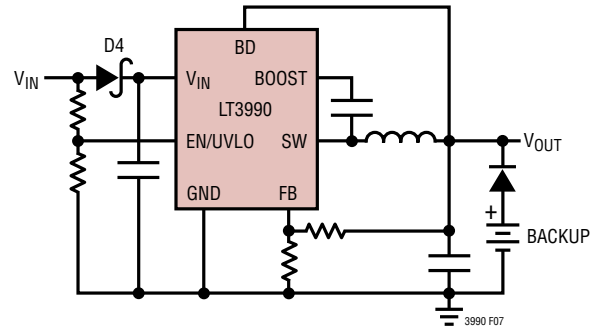

Figure 7. Diode D4 Prevents a Shorted Input from Discharging a Backup Battery Tied to the Output. It Also Protects the Circuit from a Reversed Input. The LT3990 Runs Only when the Input Is Present

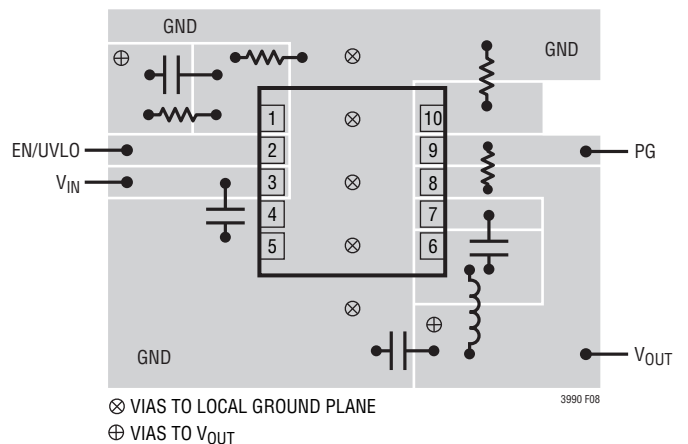

Figure 8. A Good PCB Layout Ensures Proper, Low EMI Operation

output capacitor, should be placed on the same side of the circuit board, and their connections should be made on that layer. Place a local, unbroken ground plane below these components. The SW and BOOST nodes should be as small as possible. Finally, keep the FB nodes small so that the ground traces will shield them from the SW and BOOST nodes. The exposed pad on the bottom must be soldered to ground so that the pad acts as a heat sink. To keep thermal resistance low, extend the ground plane as much as possible, and add thermal vias under and near the LT3990 to additional ground planes within the circuit board and on the bottom side.

APPLICATIONS INFORMATION

Hot Plugging Safely

The small size, robustness and low impedance of ceramic capacitors make them an attractive option for the input bypass capacitor of LT3990 circuits. However, these capacitors can cause problems if the LT3990 is plugged into a live supply. The low loss ceramic capacitor, combined with stray inductance in series with the power source, forms an under damped tank circuit, and the voltage at the V_{IN} pin of the LT3990 can ring to twice the nominal input voltage, possibly exceeding the LT3990's rating and damaging the part. If the input supply is poorly controlled or the user will be plugging the LT3990 into an energized supply, the input network should be designed to prevent this overshoot. See Linear Technology Application Note 88 for a complete discussion.

High Temperature Considerations

For higher ambient temperatures, care should be taken in the layout of the PCB to ensure good heat sinking of the LT3990. The exposed pad on the bottom must be soldered to a ground plane. This ground should be tied to large copper layers below with thermal vias; these layers will spread the heat dissipated by the LT3990. Placing additional vias can reduce thermal resistance further. The maximum load current should be derated as the ambient temperature approaches the maximum junction rating.

Power dissipation within the LT3990 can be estimated by calculating the total power loss from an efficiency measurement and subtracting inductor loss. The die temperature is calculated by multiplying the LT3990 power dissipation by the thermal resistance from junction to ambient.

Finally, be aware that at high ambient temperatures the internal Schottky diode will have significant leakage current (see Typical Performance Characteristics) increasing the quiescent current of the LT3990 converter.

Fault Tolerance

The LT3990 regulator in the MSOP package is designed to tolerate single fault conditions. Shorting any two adjacent pins together or leaving any one single pin floating does not raise V_{OUT} above the programmed value or cause damage to the part.

The NC pins are not connected to internal circuitry and must be left floating to ensure fault tolerance.

Other Linear Technology Publications

Application Notes 19, 35 and 44 contain more detailed descriptions and design information for buck regulators and other switching regulators. The LT1376 data sheet has a more extensive discussion of output ripple, loop compensation and stability testing. Design Note 100 shows how to generate a bipolar output supply using a buck regulator.

TYPICAL APPLICATIONS

3.3V Step-Down Converter

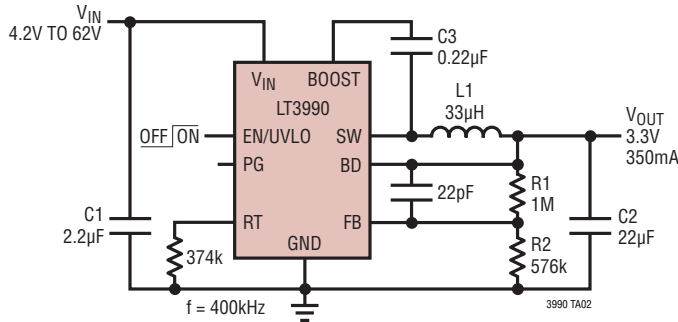

5V Step-Down Converter

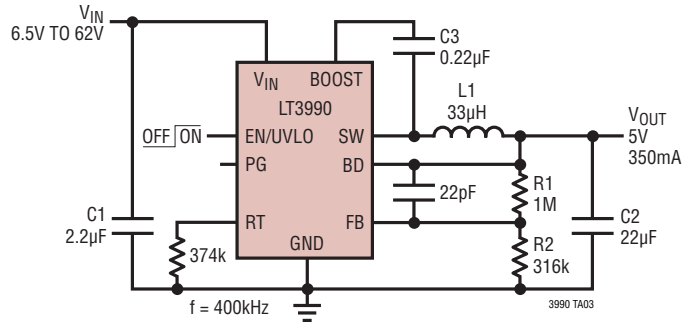

3.3V Step-Down Converter

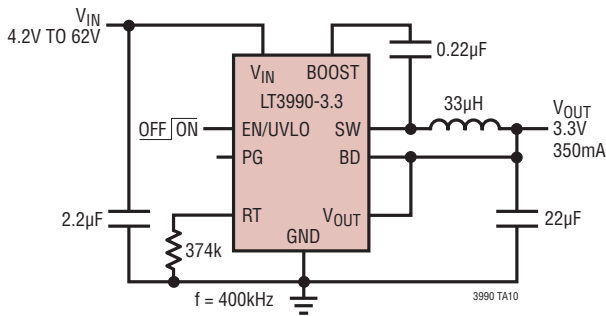

5V Step-Down Converter

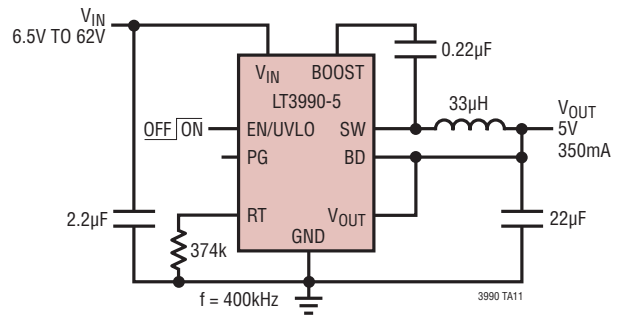

2.5V Step-Down Converter

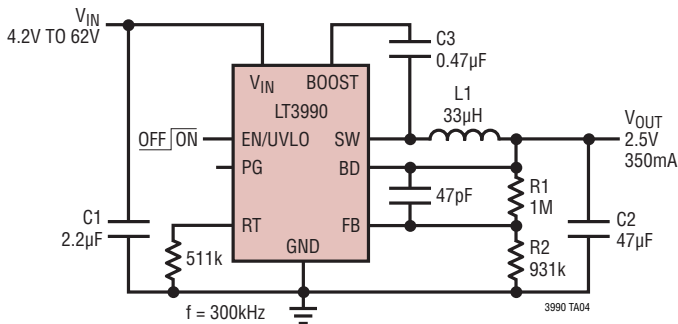

1.8V Step-Down Converter

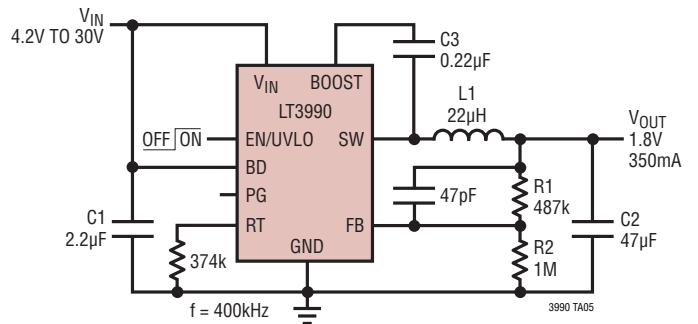

TYPICAL APPLICATIONS

12V Step-Down Converter

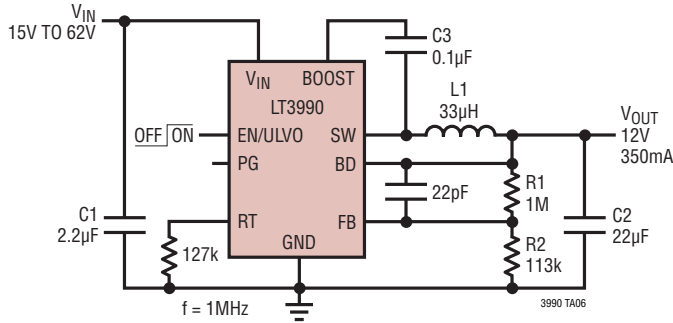

5V, 2MHz Step-Down Converter

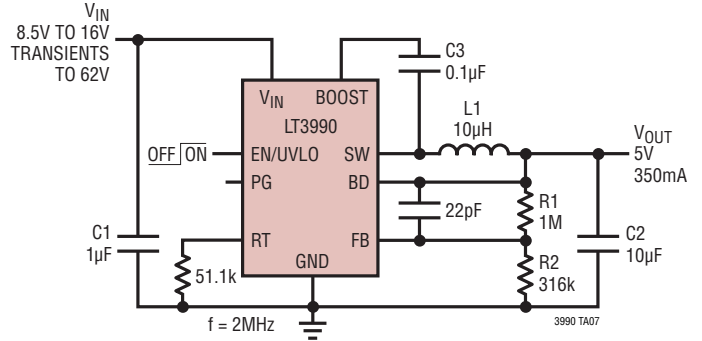

5V Step-Down Converter with Undervoltage Lockout

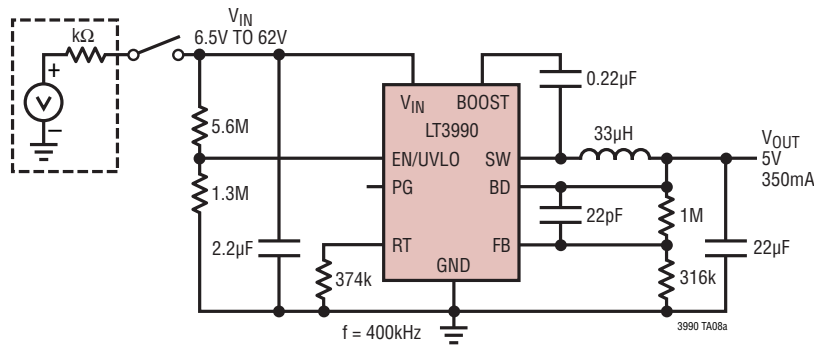

Input Current During Start-Up

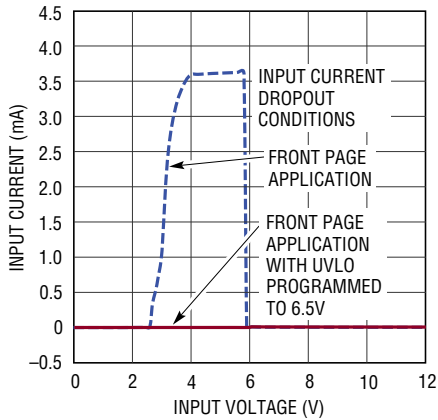

Start-Up from High Impedance Input Source

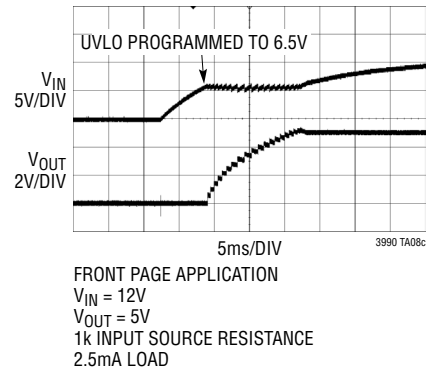

PACKAGE DESCRIPTION

Please refer to <http://www.linear.com/designtools/packaging/> for the most recent package drawings.

DD Package
10-Lead Plastic DFN (3mm × 3mm)
 (Reference LTC DWG # 05-08-1699 Rev C)

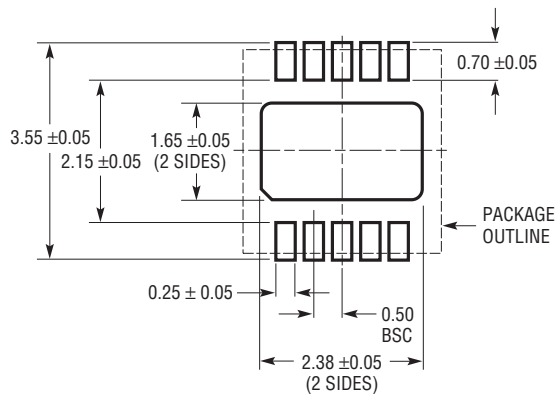

RECOMMENDED SOLDER PAD PITCH AND DIMENSIONS

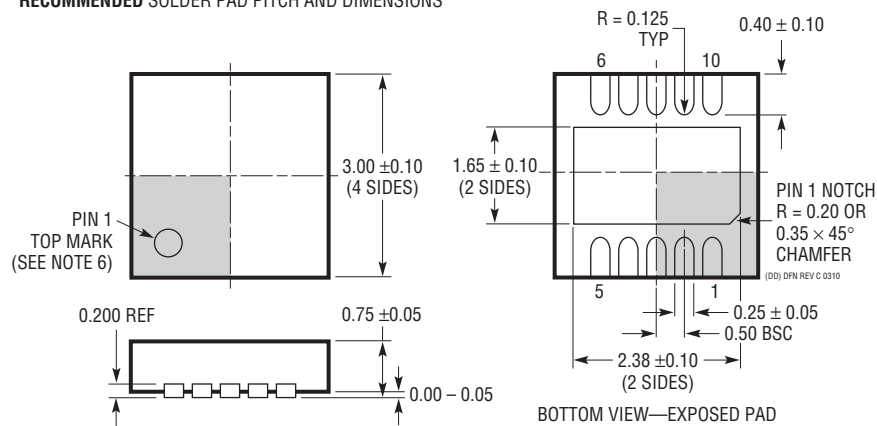

- NOTE:
1. DRAWING TO BE MADE A JEDEC PACKAGE OUTLINE M0-229 VARIATION OF (WEED-2). CHECK THE LTC WEBSITE DATA SHEET FOR CURRENT STATUS OF VARIATION ASSIGNMENT
 2. DRAWING NOT TO SCALE
 3. ALL DIMENSIONS ARE IN MILLIMETERS
 4. DIMENSIONS OF EXPOSED PAD ON BOTTOM OF PACKAGE DO NOT INCLUDE MOLD FLASH. MOLD FLASH, IF PRESENT, SHALL NOT EXCEED 0.15mm ON ANY SIDE
 5. EXPOSED PAD SHALL BE SOLDER PLATED
 6. SHADED AREA IS ONLY A REFERENCE FOR PIN 1 LOCATION ON THE TOP AND BOTTOM OF PACKAGE

PACKAGE DESCRIPTION

Please refer to <http://www.linear.com/designtools/packaging/> for the most recent package drawings.

MSE Package 16-Lead Plastic MSOP, Exposed Die Pad (Reference LTC DWG # 05-08-1667 Rev E)

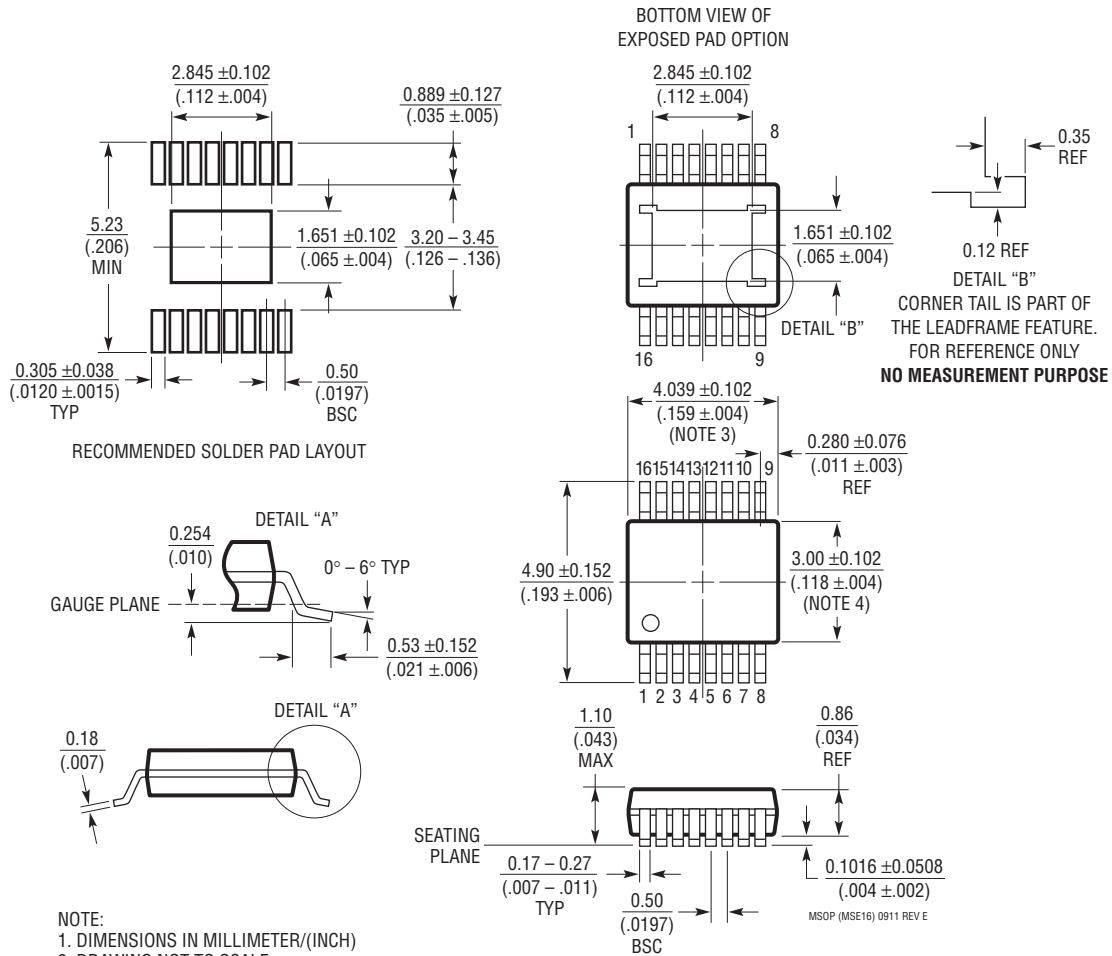

- NOTE:
1. DIMENSIONS IN MILLIMETER/(INCH)
 2. DRAWING NOT TO SCALE
 3. DIMENSION DOES NOT INCLUDE MOLD FLASH, PROTRUSIONS OR GATE BURRS.
MOLD FLASH, PROTRUSIONS OR GATE BURRS SHALL NOT EXCEED 0.152mm (.006") PER SIDE
 4. DIMENSION DOES NOT INCLUDE INTERLEAD FLASH OR PROTRUSIONS.
INTERLEAD FLASH OR PROTRUSIONS SHALL NOT EXCEED 0.152mm (.006") PER SIDE
 5. LEAD COPLANARITY (BOTTOM OF LEADS AFTER FORMING) SHALL BE 0.102mm (.004") MAX
 6. EXPOSED PAD DIMENSION DOES INCLUDE MOLD FLASH. MOLD FLASH ON E-PAD SHALL NOT EXCEED 0.254mm (.010") PER SIDE.

REVISION HISTORY (Revision history begins at Rev B)

REV	DATE	DESCRIPTION	PAGE NUMBER
B	08/12	Title, Features, Typical Application clarified to add fixed output versions	1
		Clarified Absolute Maximum Ratings, added H-grade option	2
		Clarified pinout for fixed voltage options, clarified Ordering Information for fixed output and H-grades	2
		Clarified Electrical Characteristics table	3
		Clarified Typical Performance Characteristics	4, 6
		Clarified Pin Functions and Block Diagram	7, 8
		Clarified EN/UVLO text and formula	14, 15
		Clarified Typical Applications	17

TYPICAL APPLICATION

1.21V Step-Down Converter

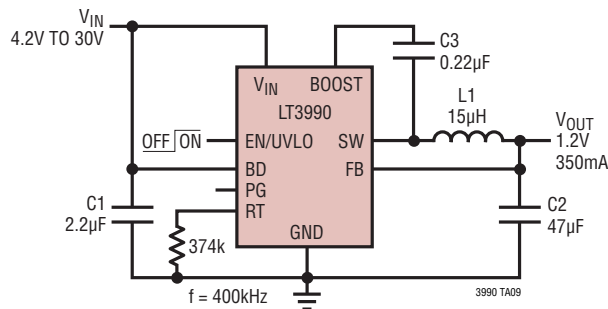

RELATED PARTS

PART NUMBER	DESCRIPTION	COMMENTS
LT3970/LT3970-3.3/ LT3970-5	40V, 350mA, 2.2MHz High Efficiency Micropower Step-Down DC/DC Converter with $I_Q = 2.5\mu\text{A}$	V_{IN} : 4.2V to 40V, $V_{OUT(MIN)} = 1.21\text{V}$, $I_Q = 2.5\mu\text{A}$, $I_{SD} < 1\mu\text{A}$, 3mm \times 2mm DFN-10, MSOP-10
LT3971	38V, 1.2A, 2.2MHz High Efficiency Micropower Step-Down DC/DC Converter with $I_Q = 2.8\mu\text{A}$	V_{IN} : 4.3V to 38V, $V_{OUT(MIN)} = 1.2\text{V}$, $I_Q = 2.8\mu\text{A}$, $I_{SD} < 1\mu\text{A}$, 3mm \times 3mm DFN-10, MSOPE-10
LT3991	55V, 1.2A, 2.2MHz High Efficiency Micropower Step-Down DC/DC Converter with $I_Q = 2.8\mu\text{A}$	V_{IN} : 4.3V to 55V, $V_{OUT(MIN)} = 1.2\text{V}$, $I_Q = 2.8\mu\text{A}$, $I_{SD} < 1\mu\text{A}$, 3mm \times 3mm DFN-10, MSOPE-10
LT3682	36V, 60V _{MAX} , 1A, 2.2MHz High Efficiency Micropower Step-Down DC/DC Converter	V_{IN} : 3.6V to 36V, $V_{OUT(MIN)} = 0.8\text{V}$, $I_Q = 75\mu\text{A}$, $I_{SD} < 1\mu\text{A}$, 3mm \times 3mm DFN-12

Looking for pricing, stock, or lifecycle information?

Click below to explore more details on WIN SOURCE:

 [View LT3990IMSE-3.3#PBF on WIN SOURCE](#)

 [Linear Technology](#) Information

Optimize Your Supply Chain with WIN SOURCE Solutions

-  Global Sourcing Solution
-  Obsolete Management
-  Cost Control Management
-  Shortage Management
-  Alternative Solution
-  Excess Inventory Management