



**THE DATASHEET OF
LT8494IUF#PBF**



SEPIC/Boost DC/DC Converter with 2A, 70V Switch, and 7 μ A Quiescent Current

FEATURES

- **Low Ripple Burst Mode[®] Operation:**
 - 7 μ A I_Q at 12V_{IN} to 5V_{OUT}
 - Output Ripple (<10mV Typ.)
- **Dual Supply Pins:**
 - Improves Efficiency
 - Reduces Minimum Supply Voltage to ~1V After Start-Up to Extend Battery Life
- **Wide Input Voltage Range of ~1V to 60V (2.5V to 32V for Start-Up)**
- **PG Functional for Input Supply Down to 1.3V**
- **FMEA Fault Tolerant in TSSOP Package**
- Fixed Frequency PWM, SEPIC/BOOST/FLYBACK Topologies
- NPN Power Switch: 2A/70V
- Programmable Switching Frequency: 250kHz to 1.5MHz
- UVLO Programmable on SWEN Pin
- Soft-Start Programmable with One Capacitor
- Small 20-Lead QFN or 20-Lead TSSOP Packages

APPLICATIONS

- Automotive ECU Power
- Power for Portable Products
- Industrial Supplies

, LT, LTC, LTM, Linear Technology, Burst Mode and the Linear logo are registered trademarks of Analog Devices, Inc. All other trademarks are the property of their respective owners.

DESCRIPTION

The **LT[®]8494** is an adjustable frequency (250kHz to 1.5MHz) monolithic switching regulator. Quiescent current can be less than 7 μ A when operating and is ~0.3 μ A when SWEN is low. The LT8494 can be configured as either a SEPIC, boost or flyback converter.

The low ripple Burst Mode operation maintains high efficiency at low output current while keeping output ripple below 10mV. Dual supply pins (V_{IN} and BIAS) allow the part to automatically operate from the most efficient supply. Input supply voltage can be up to 60V for SEPIC topologies and up to 32V (with ride-through up to 60V) for boost and flyback topologies. After start-up, battery life is extended since the part can draw current from its output (BIAS) even when V_{IN} voltage drops below 2.5V.

Using a resistor divider on the SWEN pin provides a programmable undervoltage lockout (UVLO) for the converter. A power good flag signals when V_{OUT} reaches 92% of the programmed output voltage.

Additional features such as frequency foldback and soft-start are integrated. The LT8494 is available in 20-lead QFN and 20-lead TSSOP packages with exposed pads for low thermal resistance. Fault tolerance in the TSSOP allows for adjacent pin shorts or an open without raising the output voltage above its programmed value.

TYPICAL APPLICATION

450kHz, 5V Output SEPIC Converter

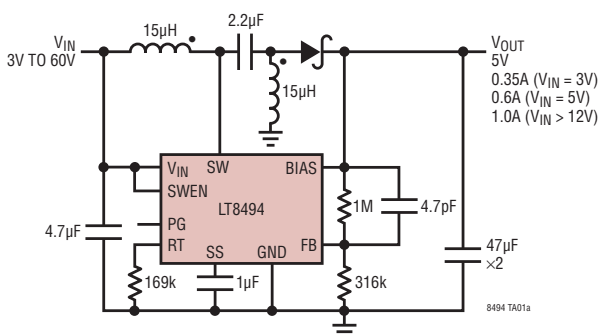

No-Load Supply Current

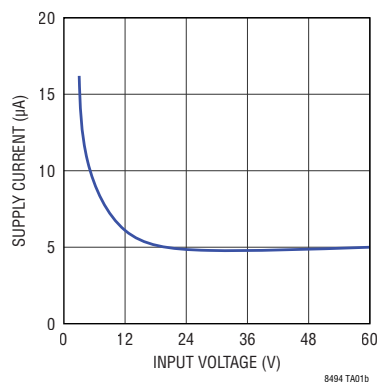

Efficiency

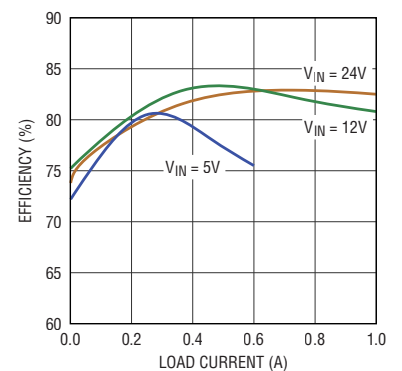

LT8494

ABSOLUTE MAXIMUM RATINGS (Note 1)

V_{IN} , BIAS Voltage.....	60V	Operating Junction Temperature Range	
SWEN Voltage.....	60V	LT8494E, LT8494I (Notes 2, 3).....	-40°C to 125°C
FB Voltage.....	60V	LT8494H (Notes 2, 3).....	-40°C to 150°C
SW Voltage.....	70V	Storage Temperature Range.....	-65°C to 150°C
PG Voltage.....	6V	Lead Temperature (Soldering, 10 sec)	
RT Voltage.....	6V	FE Package.....	300°C
SS Voltage.....	3V		

PIN CONFIGURATION

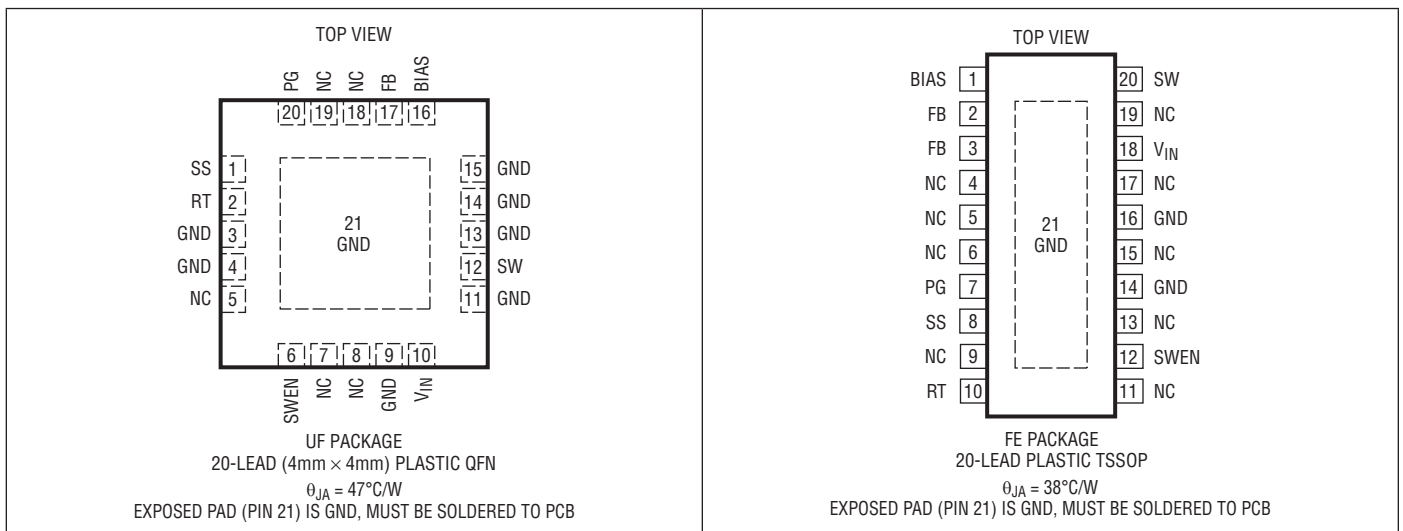

ORDER INFORMATION <http://www.linear.com/product/LT8494#orderinfo>

LEAD FREE FINISH	TAPE AND REEL	PART MARKING*	PACKAGE DESCRIPTION	TEMPERATURE RANGE
LT8494EUF#PBF	LT8494EUF#TRPBF	8494	20-Lead (4mm × 4mm) Plastic QFN	-40°C to 125°C
LT8494IUF#PBF	LT8494IUF#TRPBF	8494	20-Lead (4mm × 4mm) Plastic QFN	-40°C to 125°C
LT8494EFE#PBF	LT8494EFE#TRPBF	LT8494FE	20-Lead Plastic TSSOP	-40°C to 125°C
LT8494IFE#PBF	LT8494IFE#TRPBF	LT8494FE	20-Lead Plastic TSSOP	-40°C to 125°C
LT8494HFE#PBF	LT8494HFE#TRPBF	LT8494FE	20-Lead Plastic TSSOP	-40°C to 150°C

Consult LTC Marketing for parts specified with wider operating temperature ranges. *The temperature grade is identified by a label on the shipping container.

For more information on lead free part marking, go to: <http://www.linear.com/leadfree/>

For more information on tape and reel specifications, go to: <http://www.linear.com/tapeandreeel/>. Some packages are available in 500 unit reels through designated sales channels with #TRMPBF suffix.

ELECTRICAL CHARACTERISTICS The ● denotes the specifications which apply over the full operating junction temperature range, otherwise specifications are at $T_A = 25^\circ\text{C}$. $V_{IN} = V_{SWEN} = 12\text{V}$, $V_{BIAS} = 5\text{V}$, unless otherwise noted (Note 2).

PARAMETER	CONDITIONS		MIN	TYP	MAX	UNITS
Minimum V_{IN} Operating Voltages	$V_{BIAS} < 2.5\text{V}$	●		2.4	2.5	V
	$V_{BIAS} \geq 2.5\text{V}$	●			0	V
Minimum BIAS Operating Voltages	$V_{IN} < 2.5\text{V}$	●		2.4	2.5	V
	$V_{IN} \geq 2.5\text{V}$	●			0	V
Power Switch Driver (PSD) Overvoltage Threshold (Note 4)	V_{IN} or BIAS Rising	●	32.1	34	36.5	V
	V_{IN} or BIAS Falling	●	32	33.9	36.4	V
Power Switch Driver (PSD) Overvoltage Threshold Hysteresis (Note 4)				100		mV
Quiescent Current from V_{IN}	$V_{SWEN} = 0\text{V}$			0.3	0.9	μA
	$V_{SWEN} = 5\text{V}$, $V_{FB} = 1.25\text{V}$			3.0	4.8	μA
	$V_{SWEN} = 5\text{V}$, $V_{FB} = 1.25\text{V}$ (LT8494E, LT8494I)	●		3.0	6.2	μA
	$V_{SWEN} = 5\text{V}$, $V_{FB} = 1.25\text{V}$ (LT8494H)	●		3.0	8.0	μA
Quiescent Current from BIAS	$V_{SWEN} = 0\text{V}$			0.07	0.5	μA
	$V_{SWEN} = 5\text{V}$, $V_{FB} = 1.25\text{V}$			1.7	2.8	μA
	$V_{SWEN} = 5\text{V}$, $V_{FB} = 1.25\text{V}$ (LT8494E, LT8494I)	●		1.7	3.5	μA
	$V_{SWEN} = 5\text{V}$, $V_{FB} = 1.25\text{V}$ (LT8494H)	●		1.7	10	μA
BIAS to V_{IN} Comparator Threshold	$V_{BIAS}-V_{IN}$, V_{BIAS} Rising, $V_{IN} = 12\text{V}$	●	0.55	0.9	1.2	V
	$V_{BIAS}-V_{IN}$, V_{BIAS} Falling, $V_{IN} = 12\text{V}$	●	0.17	0.37	0.57	V
	Hysteresis (Rising-Falling Threshold)	●	0.20	0.53	0.8	V
Feedback Voltage		●	1.178	1.202	1.230	V
FB Pin Bias Current (Note 7)	$V_{FB} = 1.202\text{V}$			0.1	20	nA
FB Voltage Line Regulation	$5\text{V} \leq V_{IN} \leq 32\text{V}$, BIAS = 5V			0.2	10	m%/V
	$5\text{V} \leq V_{IN} \leq 32\text{V}$, BIAS = 0V			0.2	10	m%/V
Minimum Switch Off-Time				70		ns
Minimum Switch On-Time				95		ns
Switching Frequency	$R_T = 68.1\text{k}$	●	0.92	1.0	1.06	MHz
	$R_T = 324\text{k}$	●	219	250	280	kHz
Switch Current Limit at Minimum Duty Cycle (Note 5)		●	2.1	2.55	2.95	A
Switch Current Limit at Maximum Duty Cycle (Note 6)		●	1.3	1.85	2.4	A
Switch V_{CESAT}	$I_{SW} = 1.2\text{A}$			340		mV
Switch Leakage Current (Note 7)	$V_{SW} = 12\text{V}$, $V_{SWEN} = 0\text{V}$			0.01	1	μA
Soft-Start Charging Current (Note 7)	$V_{SS} = 100\text{mV}$	●	5.2	8.2	12.2	μA
SWEN Pin Current (Note 7)	$V_{SWEN} = 1.2\text{V}$			0	25	nA
	$V_{SWEN} = 5\text{V}$			35	200	nA
	$V_{SWEN} = 12\text{V}$			240	550	nA
SWEN Rising Voltage Threshold		●	0.9	1	1.1	V
SWEN Voltage Hysteresis				30		mV
PG Threshold as % of V_{FB} Regulation Voltage	V_{FB} Rising	●	86	92	97	%
	V_{FB} Falling	●	82	88	93	%
PG Hysteresis				46		mV
PG Output Voltage Low	$I_{SINK} = 1.25\text{mA}$	●		33	150	mV
	$I_{SINK} = 100\mu\text{A}$, $V_{BIAS} = 0\text{V}$, $V_{IN} = 1.3\text{V}$	●		15	150	mV
	$I_{SINK} = 100\mu\text{A}$, $V_{BIAS} = 1.3\text{V}$, $V_{IN} = 0\text{V}$	●		15	150	mV
PG Leakage Current	$V_{PG} = 5\text{V}$ (LT8494E, LT8494I)	●		0	0.3	μA
	$V_{PG} = 5\text{V}$ (LT8494H)	●		0	1.0	μA

ELECTRICAL CHARACTERISTICS

Note 1: Stresses beyond those listed under Absolute Maximum Ratings may cause permanent damage to the device. Exposure to any Absolute Maximum Rating condition for extended periods may affect device reliability and lifetime. Voltages are with respect to GND pin unless otherwise noted.

Note 2: The LT8494E is guaranteed to meet performance specifications from 0°C to 125°C junction temperature. Specifications over the -40°C to 125°C operating junction temperature range are assured by design, characterization and correlation with statistical process controls. The LT8494I is guaranteed to meet performance specifications from -40°C to 125°C junction temperature. The LT8494H is guaranteed over the full -40°C to 150°C operating junction temperature range. Operation lifetime is derated at junction temperatures greater than 125°C.

Note 3: This IC includes overtemperature protection that is intended to protect the device during momentary overload conditions.

Junction temperature will exceed the maximum operating range when overtemperature protection is active. Continuous operation above the specified maximum operating junction temperature may impair device reliability.

Note 4: See Power Supplies and Operating Limits in the Applications Information section for more details.

Note 5: Current limit guaranteed by design and/or correlation to static test. Slope Compensation reduces current limit at higher duty cycles.

Note 6: Max duty cycle current limit measured at 1MHz switching frequency.

Note 7: Polarity specification for all currents into pins is positive. All voltages are referenced to GND unless otherwise specified.

TYPICAL PERFORMANCE CHARACTERISTICS $T_A = 25^\circ\text{C}$ unless otherwise specified.

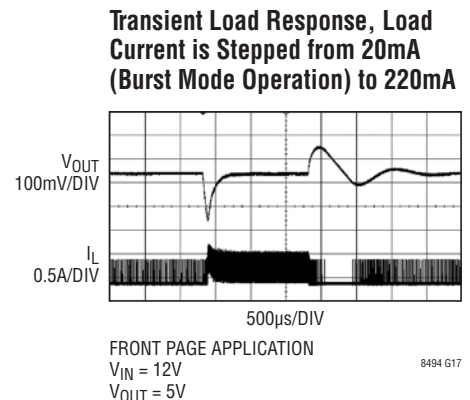
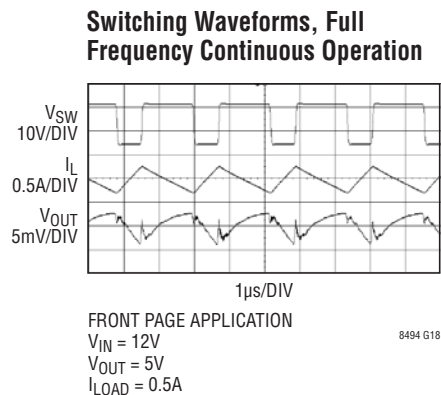
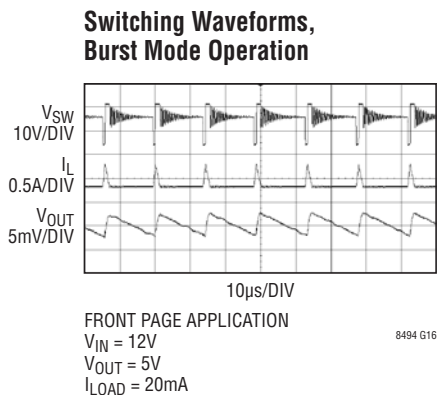
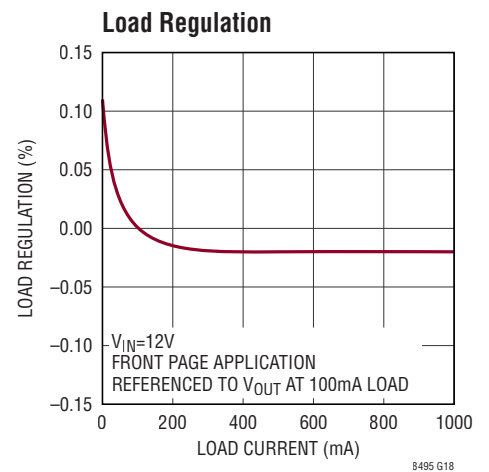
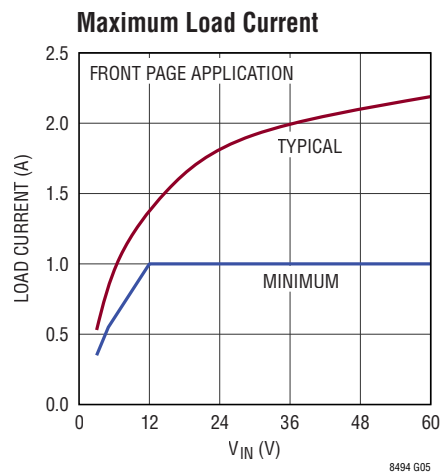
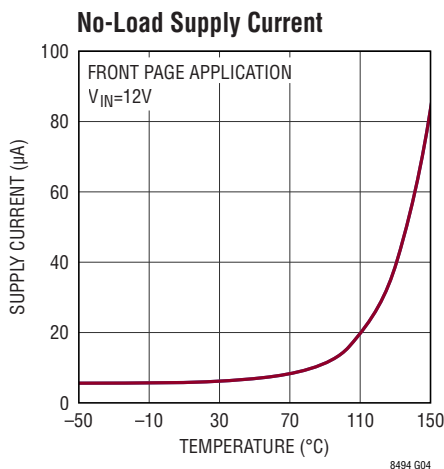

TYPICAL PERFORMANCE CHARACTERISTICS $T_A = 25^\circ\text{C}$ unless otherwise specified.

Transient Load Response, Load Current is Stepped from 300mA to 500mA

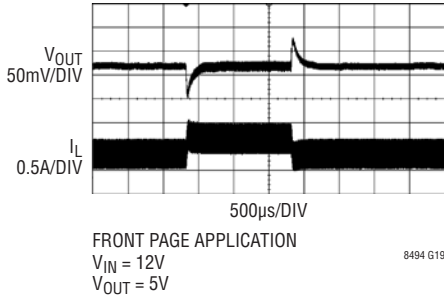

Switch Current Limit at 500kHz

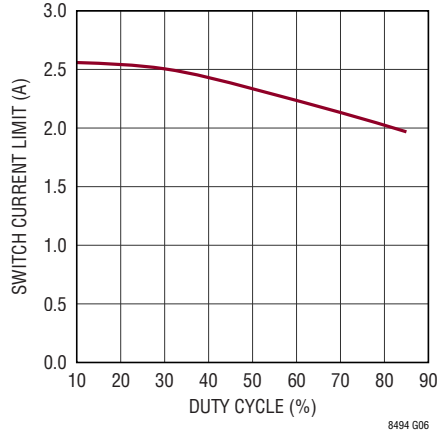

Switch Current Limit at Minimum Duty Cycle

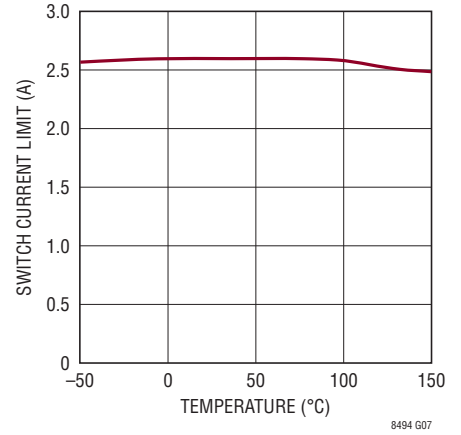

Switch V_{CESAT}

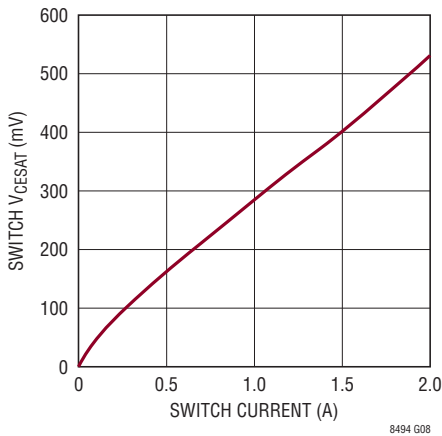

Feedback Voltage

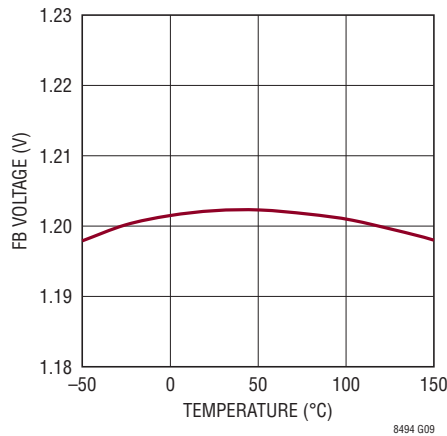

Oscillator Frequency

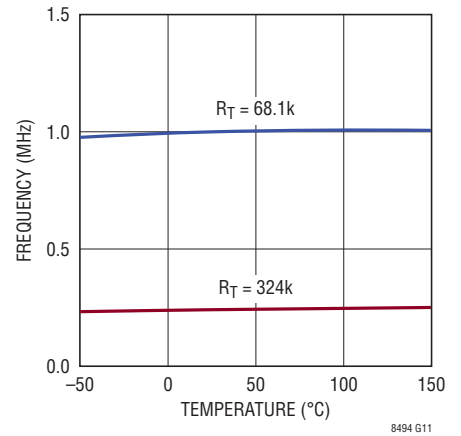

Frequency Foldback

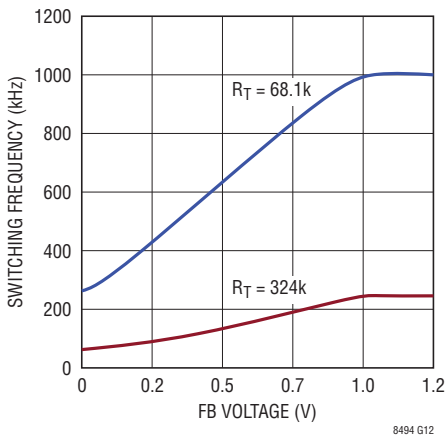

Minimum Switch On-Time

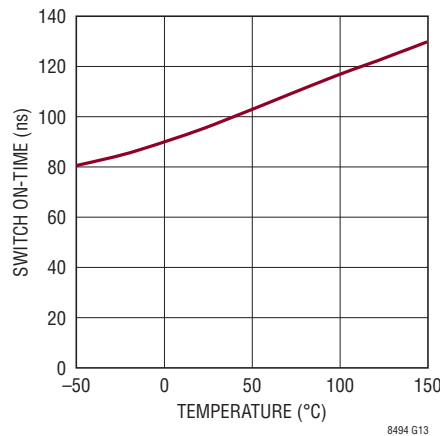

Minimum Switch Off-Time

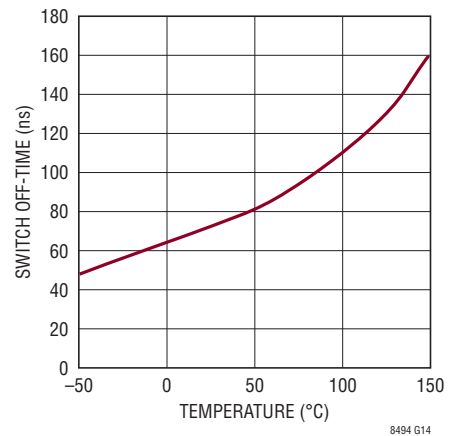

TYPICAL PERFORMANCE CHARACTERISTICS $T_A = 25^\circ\text{C}$ unless otherwise specified.

Overvoltage Lockout

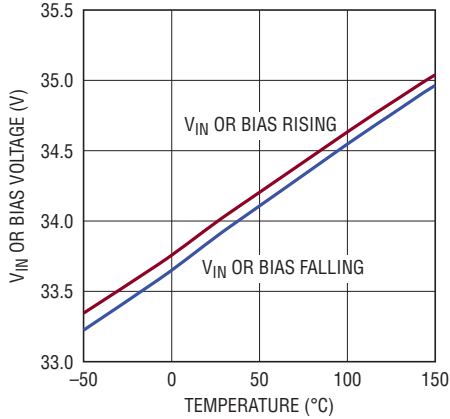

8494 G15

Internal UVLO

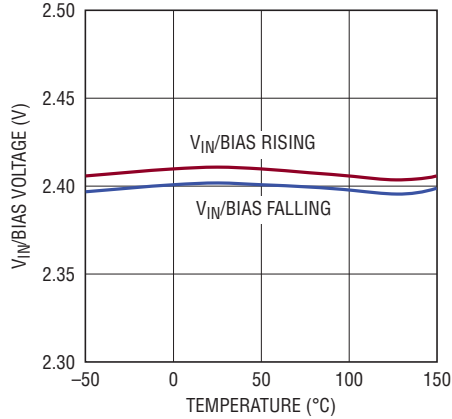

8494 G20

PG Pin Current vs Supply Voltage

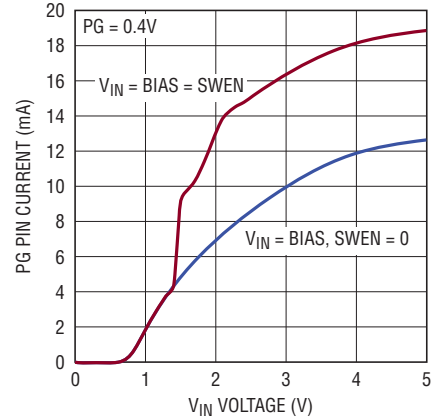

8494 G22

SWEN Pin Current

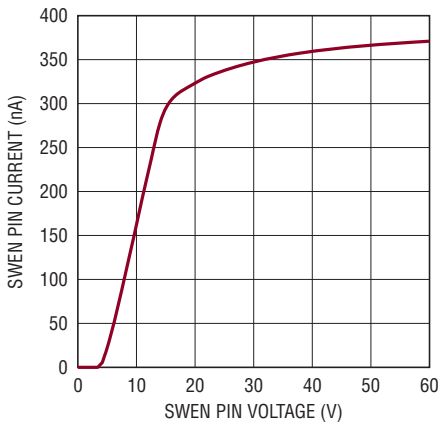

8494 G23

FB Pin Current

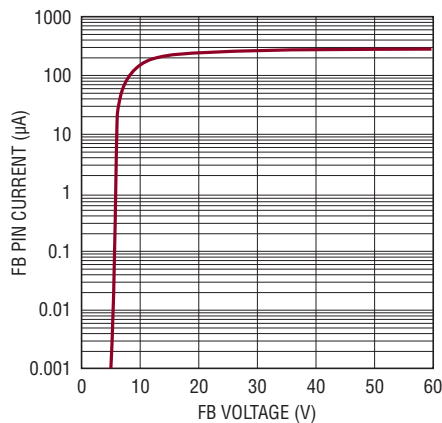

8494 G24

PG Output Voltage vs Supply Voltage

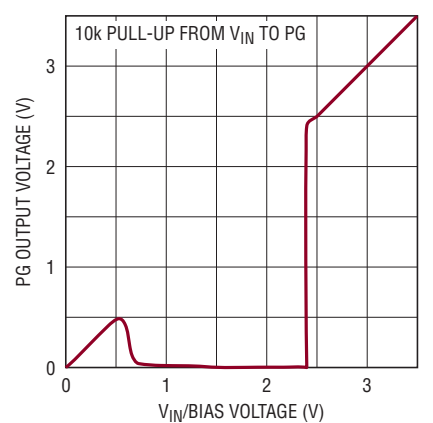

8494 G25

Pin Current

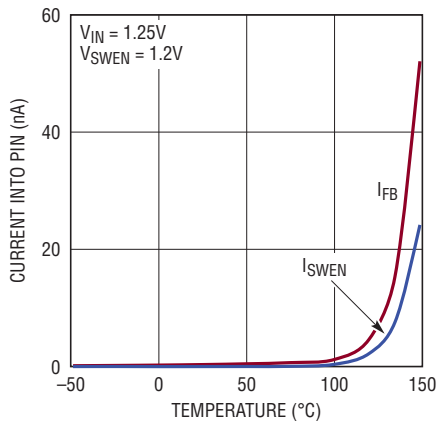

8494 G26

Quiescent Current

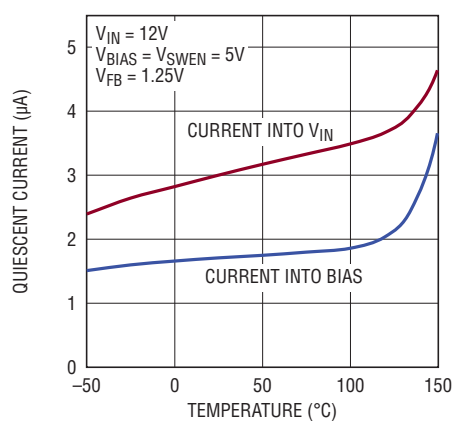

8494 G27

PIN FUNCTIONS (QFN/TSSOP)

SS (Pin 1/Pin 8): Soft-Start Pin. Place a soft-start capacitor on this pin. Upon start-up, the SS pin will be charged by a (nominally) 256k resistor to about 2.1V.

RT (Pin 2/Pin 10): Oscillator Frequency Set Pin. Place a resistor from this pin to ground to set the internal oscillator frequency. Minimize capacitance on this pin. See the Applications Information section for more details.

GND (Pins 3, 4, 9, 11, 13, 14, 15, Exposed Pad 21/Pins 14, 16, Exposed Pad 21): Ground. Solder all pins and the exposed pad directly to the local ground plane. The exposed pad metal of the package provides both electrical contact to ground and good thermal contact to the printed circuit board.

NC (Pins 5, 7, 8, 18, 19/4, 5, 6, 9, 11, 13, 15, 17, 19): NC pins are not connected to internal circuitry. Some NC pins in the TSSOP package must be left floating to ensure FMEA fault tolerance (see Applications Information section for details).

SWEN (Pin 6/Pin 12): Switch Enable Detect Pin. This pin enables/disables the switching regulator and soft-start. A resistor divider can be connected to SWEN to perform an undervoltage lockout function.

V_{IN} (Pin 10/Pin 18): Supply Input Pin. This pin is typically connected to the input of the DC/DC converter. Must be locally bypassed.

SW (Pin 12/Pin 20): Switch Pin. This is the collector of the internal NPN power switch. Minimize trace area connected to this pin to minimize EMI.

BIAS (Pin 16/Pin 1): Supply Input Pin. This pin is typically connected to the output of the DC/DC converter in cases where V_{IN} can be higher than V_{OUT}. Must be locally bypassed.

FB (Pin 17/Pin 2, 3): Output Voltage Feedback Pin. The LT8494 regulates the FB pin to 1.202V. Connect a resistor divider between the output, FB and GND to set the regulated output voltage.

PG (Pin 20/Pin 7): The PG pin is the open-drain output of an internal comparator. PG remains low until the FB pin is above 92% of the regulation voltage, and there are no fault conditions. See the Applications Information section for more details.

OPERATION

The LT8494 is a constant-frequency, current mode SEPIC/boost/flyback regulator. Operation can be best understood by referring to the Block Diagram. In the Block Diagram, the adjustable oscillator, with frequency set by the external R_T resistor, enables an RS latch, turning on the internal power switch. An amplifier and comparator monitor the switch current flowing through an internal sense resistor, turning the switch off when this current reaches a level determined by the voltage at VC. An error amplifier adjusts the VC voltage by measuring the output voltage through an external resistor divider tied to the FB pin. If the error amplifier's output voltage (VC) increases, more current is delivered to the output; if the VC voltage decreases, less current is delivered. An active clamp on the VC voltage provides current limit. An internal regulator provides power to the control circuitry.

In order to improve efficiency, the NPN power switch driver (see Block Diagram) supplies NPN base current from whichever of V_{IN} and BIAS has the lower supply voltage. However, if either of them is below 2.4V or above 34V (typical values), the power switch draws current from the other pin. If both supply pins are below 2.4V or above 34V then switching activity is stopped.

To further optimize efficiency, the LT8494 automatically enters Burst Mode operation in light load situations. Between bursts, all circuitry associated with controlling the output switch is shut down, reducing the V_{IN} /BIAS pin supply currents to be less than 3 μ A typically (see Electrical Characteristics).

The LT8494 contains a power good comparator which trips when the FB pin is above 92% of its regulated value. The PG output is an open-drain transistor that is off when the output is in regulation, allowing an external resistor to pull the PG pin high (See Applications Information section for details).

Several functions are provided to enable a very clean start-up for the LT8494.

- First, the SWEN pin voltage is monitored by an internal voltage reference to give a precise turn-on threshold. An external resistor divider can be connected from the input power supply to the SWEN pin to provide a user-programmable undervoltage lockout function.
- Second, the soft-start circuitry provides for a gradual ramp-up of the switch current. When the part is brought out of shutdown, the external SS capacitor is first discharged, and then an integrated 256k resistor pulls the SS pin up to ~2.1V. By connecting an external capacitor to the SS pin, the voltage ramp rate on the pin can be set. Typical values for the soft-start capacitor range from 100nF to 1 μ F.
- Finally, the frequency foldback circuit reduces the maximum switching frequency when the FB pin is below 1V. This feature reduces the minimum duty cycle that the part can achieve thus allowing better control of the switch current during start-up.

APPLICATIONS INFORMATION

Low Ripple Burst Mode Operation

To enhance efficiency at light loads, the LT8494 regulator enters low ripple Burst Mode operation keeping the output capacitor charged to the proper voltage while minimizing the input quiescent current. During Burst Mode operation, the LT8494 regulator delivers single-cycle bursts of current to the output capacitor with each followed by a sleep period where the output power is delivered to the load by the output capacitor. The quiescent currents of $V_{IN}/BIAS$ are reduced to less than $3\mu A$ typically during the sleep time (see Electrical Characteristics table).

As the load current decreases towards a no-load condition, the frequency of single current pulses decreases (see Figure 1), therefore the percentage of time that the LT8494 operates in sleep mode increases, resulting in reduced average input current and thus high efficiency even at very low loads.

By maximizing the time between pulses, the LT8494 quiescent current is minimized. Therefore, to optimize the quiescent current performance at light loads, the current in the feedback resistor divider and the reverse current in the external diode must be minimized, as these appear to the output as load currents. More specifically, during the sleep time, the boost converter has the reverse diode leakage current conducting from output to input, while the SEPIC converter has leakage current conducting from output to ground. Use the largest possible feedback

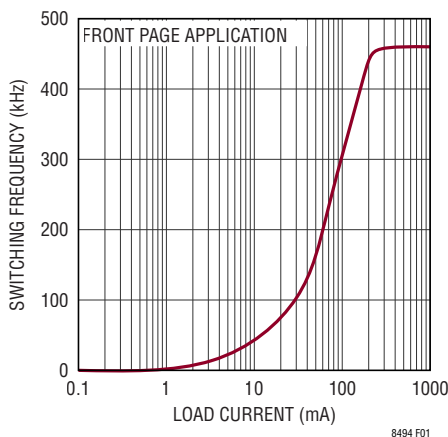

Figure 1. Switching Frequency in Burst Mode Operation

resistors and a low leakage Schottky diode in applications with ultralow Q current.

In Burst Mode operation, the burst frequency and the charge delivered with each pulse will not change with output capacitance. Therefore, the output voltage ripple will be inversely proportional to the output capacitance. In a typical application with a $47\mu F$ output capacitor, the output ripple is about 10mV, and with two $47\mu F$ output capacitors the output ripple is about 5mV (see Switching Waveforms, Burst Mode Operation in Typical Performance Characteristics section). The output voltage ripple can continue to be decreased by increasing the output capacitance.

At higher output loads the LT8494 regulator runs at the frequency programmed by the R_T resistor and operates as a standard current mode regulator. The transition between high current mode and low ripple Burst Mode operation is seamless, and will not disturb the output voltage.

Setting the Output Voltage

The output voltage is programmed with a resistor divider from output to the FB pin (R_2) and from the FB pin to ground (R_1). Choose the 1% resistors according to:

$$R_2 = R_1 \left(\frac{V_{OUT}}{1.202} - 1 \right)$$

Note that choosing larger resistors decreases the quiescent current of the application circuits. In low load applications, choosing larger resistors is more critical since the part enters Burst Mode operation with lower quiescent current.

Power Switch Duty Cycle

In order to maintain loop stability and deliver adequate current to the load, the power NPN (Q_1 in the Block Diagram) cannot remain on for 100% of each clock cycle. The maximum allowable duty cycle is given by:

$$DC_{MAX} = \frac{T_P - \text{Minimum Switch Off-Time}}{T_P} \cdot 100\%$$

APPLICATIONS INFORMATION

where T_P is the clock period and Minimum Switch Off-Time (found in the Electrical Characteristics) is typically 70ns.

Conversely, the power NPNs (Q1 in the Block Diagram) cannot remain off for 100% of each clock cycle, and will turn on for a minimum time (Minimum Switch On-Time) when in regulation. This Minimum Switch On-Time governs the minimum allowable duty cycle given by:

$$DC_{MIN} = \frac{\text{Minimum Switch On-Time}}{T_P} \cdot 100\%$$

where T_P is the clock period and Minimum Switch On-Time (found in the Electrical Characteristics) is typically 95ns.

The application should be designed such that the operating duty cycle (DC) is between DC_{MIN} and DC_{MAX} . Normally, DC rises with higher V_{OUT} and lower V_{IN} .

Duty cycle equations for both boost and SEPIC topologies are given below, where V_D is the diode forward voltage drop and V_{CESAT} is typically 340mV at 1.2A.

For the boost topology:

$$DC \cong \frac{V_{OUT} - V_{IN} + V_D}{V_{OUT} + V_D - V_{CESAT}}$$

For the SEPIC topology:

$$DC \cong \frac{V_{OUT} + V_D}{V_{IN} + V_{OUT} + V_D - V_{CESAT}}$$

The LT8494 can be used in configurations where the duty cycle is higher than DC_{MAX} , but it must be operated in the discontinuous conduction mode or Burst Mode operation so that the effective duty cycle is reduced.

Setting the Switching Frequency

The LT8494 uses a constant frequency PWM architecture that can be programmed to switch from 250kHz to 1.5MHz by using a resistor tied from the R_T pin to ground. Table 1 shows the necessary R_T values for various switching frequencies.

Table 1. Switching Frequency vs R_T Value

SWITCHING FREQUENCY (MHz)	R_T VALUE (k Ω)
0.25	324
0.4	196
0.6	124
0.8	88.7
1.0	68.1
1.2	54.9
1.4	45.3
1.5	41.2

Inductor Selection

General Guidelines: The high frequency operation of the LT8494 allows for the use of small surface mount inductors. For high efficiency, choose inductors with high frequency core material, such as ferrite, to reduce core losses. To improve efficiency, choose inductors with more volume for a given inductance. The inductor should have low DCR (copper wire resistance) to reduce I^2R losses, and must be able to handle the peak inductor current without saturating. Note that in some applications, the current handling requirements of the inductor can be lower, such as in the SEPIC topology when using uncoupled inductors, where each inductor only carries a fraction of the total switch current. Molded chokes or chip inductors usually do not have enough core area to support peak inductor currents in the 2A to 3A range. To minimize radiated noise, use a toroidal or shielded inductor. Note that the inductance of shielded types will drop more as current increases, and will saturate more easily.

Minimum Inductance: Although there can be a trade-off with efficiency, it is often desirable to minimize board space by choosing smaller inductors. When choosing an inductor, there are two conditions that limit the minimum inductance; (1) providing adequate load current, and (2) avoidance of subharmonic oscillation. Choose an inductance that is high enough to meet both of these requirements.

APPLICATIONS INFORMATION

Adequate Load Current: Small value inductors result in increased ripple currents and thus, due to the limited peak switch current, decrease the average current that can be provided to a load (I_{OUT}). In order to provide adequate load current, L should be at least:

$$L > \frac{DC \cdot V_{IN}}{2(f) \left(I_{LIM} - \frac{V_{OUT} \cdot I_{OUT}}{V_{IN} \cdot \eta} \right)}$$

For boost topologies, or:

$$L > \frac{DC \cdot V_{IN}}{2(f) \left(I_{LIM} - \frac{V_{OUT} \cdot I_{OUT}}{V_{IN} \cdot \eta} - I_{OUT} \right)}$$

for the SEPIC topologies.

where:

$L = L1 || L2$ for the uncoupled SEPIC topology

DC = switch duty cycle (see previous section)

I_{LIM} = switch current limit, typically about 2.35A at 50% duty cycle (see the Typical Performance Characteristics section)

η = power conversion efficiency (typically 85% to 90% for boost and 80% to 85% for SEPIC at high currents)

f = switching frequency

Negative values of L indicate that the output load current I_{OUT} exceeds the switch current limit capability of the LT8494.

Avoiding Subharmonic Oscillations: The internal slope compensation circuit of LT8494 helps prevent the subharmonic oscillations that can occur when the duty cycle is greater than 50%, provided that the inductance exceeds a minimum value. In applications that operate with duty cycles greater than 50%, the inductance must be at least:

$$L > \frac{(V_{IN} - V_{CESAT}) \cdot (2DC - 1)}{0.76 \cdot (1.5 \cdot DC + 1) \cdot f \cdot (1 - DC)}$$

for boost and coupled inductor SEPIC, or:

$$L1 || L2 > \frac{(V_{IN} - V_{CESAT}) \cdot (2DC - 1)}{0.76 \cdot (1.5 \cdot DC + 1) \cdot f \cdot (1 - DC)}$$

for the uncoupled inductor SEPIC topologies.

Maximum Inductance: Excessive inductance can reduce current ripple to levels that are difficult for the current comparator (A2 in the Block Diagram) to cleanly discriminate, thus causing duty cycle jitter and/or poor regulation. The maximum inductance can be calculated by:

$$L_{MAX} = \frac{V_{IN} - V_{CESAT}}{I_{MIN(RIPPLE)}} \cdot \frac{DC}{f}$$

where L_{MAX} is $L1 || L2$ for uncoupled SEPIC topologies and $I_{MIN(RIPPLE)}$ is typically 150mA.

Current Rating: Finally, the inductor(s) must have a rating greater than its peak operating current to prevent inductor saturation resulting in efficiency loss.

In steady state, the peak and average input inductor currents (continuous conduction mode only) are given by:

$$I_{L1(PEAK)} = \frac{V_{OUT} \cdot I_{OUT}}{V_{IN} \cdot \eta} + \frac{V_{IN} \cdot DC}{2 \cdot L1 \cdot f}$$

$$I_{L1(AVG)} = \frac{V_{OUT} \cdot I_{OUT}}{V_{IN} \cdot \eta}$$

for the boost and uncoupled inductor SEPIC topology.

For uncoupled SEPIC topologies, the peak and average currents of the output inductor L2 are given by:

$$I_{L2(PEAK)} = I_{OUT} + \frac{V_{OUT} \cdot (1 - DC)}{2 \cdot L2 \cdot f}$$

$$I_{L2(AVG)} = I_{OUT}$$

APPLICATIONS INFORMATION

For the coupled inductor SEPIC:

$$I_{L(\text{PEAK})} = I_{\text{OUT}} \cdot \left(1 + \frac{V_{\text{OUT}}}{V_{\text{IN}} \cdot \eta} \right) + \frac{V_{\text{IN}} \cdot \text{DC}}{2 \cdot L \cdot f}$$

$$I_{L(\text{AVG})} = I_{\text{OUT}} \cdot \left[1 + \frac{V_{\text{OUT}}}{V_{\text{IN}} \cdot \eta} \right]$$

Note: Inductor current can be higher during load transients. It can also be higher during short-circuit and start-up if inadequate soft-start capacitance is used. Thus, $I_{L(\text{PEAK})}$ may be higher than the switch current limit of 2.95A, and the RMS inductor current is approximately equal to $I_{L(\text{AVG})}$. Choose an inductor having sufficient saturation current and RMS current ratings.

Capacitor Selection

Low ESR (equivalent series resistance) capacitors should be used at the output to minimize the output ripple voltage. Multilayer ceramic capacitors are an excellent choice, as they have an extremely low ESR and are available in very small packages. X5R or X7R dielectrics are preferred, as these materials retain their capacitance over wider voltage and temperature ranges. Always use a capacitor with a sufficient voltage rating. Many capacitors rated at 2.2 μ F to 20 μ F, particularly 0805 or 0603 case sizes, have greatly reduced capacitance at the desired output voltage. Solid tantalum or OS-CON capacitors can be used, but they will occupy more board area than a ceramic and will have a higher ESR with greater output ripple.

Ceramic capacitors also make a good choice for the input decoupling capacitor, which should be placed as closely as possible to the V_{IN} and BIAS pins of the LT8494. A 2.2 μ F to 4.7 μ F input capacitor is sufficient for most applications.

Audible Noise

Ceramic capacitors are small, robust and have very low ESR. However, due to their piezoelectric nature, ceramic capacitors can sometimes create audible noise when used with the LT8494. During Burst Mode operation, the LT8494 regulator's switching frequency depends on the load current, and at very light loads the regulator can

excite the ceramic capacitor at audio frequencies, generating audible noise. Since LT8494 operates at a lower current limit during Burst Mode operation, the noise is typically very quiet. If this is unacceptable, use a high performance tantalum or electrolytic capacitor at the output.

Diode Selection

The diode used in boost or SEPIC topologies conducts current only during the switch off-time. During the switch on-time, the diode has reverse voltage across it. The peak reverse voltage is equal to V_{OUT} in the boost topology and equal to $(V_{\text{OUT}} + V_{\text{IN}})$ in the SEPIC topology. Use a diode with a reverse voltage rating greater than the peak reverse voltage.

An additional consideration is the reverse leakage current. The leakage current appears to the output as load current and affects the efficiency, most noticeably, under light load conditions. In Burst Mode operation, after the inductor current vanishes, the reverse voltage across the boost diode is approximately equal to $V_{\text{OUT}} - V_{\text{IN}}$ in the boost topology and V_{OUT} in the SEPIC topology. The percentage of time that the diode is reverse biased increases as load current decreases.

Schottky diodes that have larger forward voltages often have less leakage, so a trade-off exists between light load and high load efficiency. Also the Schottky diodes with larger reverse bias ratings may have less leakage at a given output voltage, therefore, superior leakage performance can be achieved at the expense of diode size. Finally, keep in mind that the leakage current of a power Schottky diode goes up exponentially with junction temperature. Therefore, the Schottky diode must be selected with care to avoid excessive increase in light load supply current at high temperatures.

Soft-Start

The LT8494 contains a soft-start circuit to limit peak switch currents during start-up. High start-up current is inherent in switching regulators since the feedback loop is saturated due to V_{OUT} being far from its final value. The

APPLICATIONS INFORMATION

regulator tries to charge the output capacitor as quickly as possible, which results in large peak currents. The start-up current can be limited by connecting an external capacitor (typically 100nF to 1 μ F) to the SS pin. This capacitor is slowly charged to \sim 2.1V by an internal 256k resistor once the part is activated. SS pin voltages below \sim 0.8V reduce the internal current limit. Thus, the gradual ramping of the SS voltage also gradually increases the current limit as the capacitor charges. This, in turn, allows the output capacitor to charge gradually toward its final value while limiting the start-up current. When the switching regulator shuts down, the soft-start capacitor is automatically discharged to \sim 100mV or less before charging resumes, thus assuring that the soft-start occurs after every reactivation of the switching regulation.

Power Supplies and Operating Limits

The LT8494 draws supply current from the V_{IN} and BIAS pins. The largest supply current draw occurs when the switching regulator is enabled (SWEN is high) and the power switch is toggling on and off. Under light load conditions the switching regulator enters Burst Mode operation where the power switch toggles infrequently and the input current is significantly reduced (see the Low Ripple Burst Mode Operation section).

Power Switch Driver (PSD) Operating Range: The NPN power switch is driven by a power switch driver (PSD) as shown in the Block Diagram. The driver must be powered by a supply (V_{IN} or BIAS) that is above the minimum operating voltage and below the PSD overvoltage threshold. These voltages are typically 2.4V and 34V respectively (see Electrical Characteristics).

If neither V_{IN} nor BIAS is within this operating range, the PSD and the switching regulator are automatically disabled. Voltages up to 60V are not harmful to the PSD, however, as discussed, switching regulation is automatically disabled when neither V_{IN} nor BIAS is in the valid operating range.

When both V_{IN} and BIAS are too low for proper LT8494 operation (typically $<$ 2.4V), the chip will enter shutdown and draw minimal current from both supplies.

Automatic Power Supply Selection: In order to minimize power loss, the LT8494 draws as much of its required current as possible from the lowest suitable voltage supply (V_{IN} or BIAS) in accordance with the requirements described in the previous two sections. This selection is automatic and can change as V_{IN} and/or BIAS voltages change.

The LT8494 compares the V_{IN} and BIAS voltages to determine which is lower. The comparator has an offset and hysteresis as shown in the Electrical Characteristics section. The voltage comparison happens continuously when the power switch is toggling. The result of the latest comparison is latched inside the LT8494 when switching stops. If the power switch is not toggling, the LT8494 uses the last V_{IN} vs BIAS comparison to determine which supply is lower. After initial power up or any thermal lock-out the LT8494 always concludes that V_{IN} is the lower supply voltage until subsequent voltage comparisons can be made while the power switch is toggling.

BIAS Connection for SEPIC Converters: For SEPIC converters, where V_{IN} can be above or below V_{OUT} , BIAS is typically connected to V_{OUT} which improves efficiency when V_{IN} voltage is higher than V_{OUT} . Connecting BIAS to V_{OUT} in a SEPIC topology also allows the switching regulator to operate with V_{IN} above 34V (typical switch driver overvoltage threshold) in cases where V_{OUT} is regulated below the PSD overvoltage threshold. Finally, connecting BIAS to V_{OUT} also allows the converter to operate from V_{IN} voltages less than 2.4V after V_{OUT} rises within the PSD operating range. This can be very useful in battery powered applications since the battery voltage drops as it discharges.

BIAS Connection for Boost Converters: For boost converters, BIAS is typically connected to V_{OUT} or to ground. Connecting BIAS to V_{OUT} allows the converter to operate with $V_{IN} <$ 2.5V after V_{OUT} has risen within the PSD operating range. However, during no load conditions on V_{OUT} , despite V_{IN} being selected as the primary input supply, the overall power loss will be slightly elevated due to the small amount of current still being drawn from the higher voltage BIAS pin. To minimize boost converter power loss during no load conditions, connect BIAS instead to ground.

APPLICATIONS INFORMATION

For boost applications with V_{OUT} higher than the PSD operating range, the BIAS pin should not typically be connected to V_{OUT} . The LT8494 will never draw the majority of its current from BIAS due to the excessive voltage, therefore this connection does not help to improve efficiency. Alternative choices for the BIAS pin connection are ground or another supply that is within the PSD operating range.

Maximum V_{IN} for Boost Converters: V_{IN} cannot generally be higher than V_{OUT} in boost topologies because of the DC path from V_{IN} to V_{OUT} through the inductor and the output diode. If V_{IN} must be higher than V_{OUT} , then the inductor must be powered by a separate supply that is always below V_{OUT} . Otherwise a SEPIC topology can be used.

Also, the LT8494 will not operate in a boost topology with V_{IN} voltages above the PSD operating range unless BIAS is connected to an alternative supply within the valid operating range.

V_{IN} /BIAS Ramp Rate: While initially powering a switching converter application, the V_{IN} /BIAS ramp rate should be limited. High V_{IN} /BIAS ramp rates can cause excessive inrush currents in the passive components of the converter. This can lead to current and/or voltage overstress and may damage the passive components or the chip. Ramping rates less than $500\text{mV}/\mu\text{s}$, depending on component parameters, will generally prevent these issues. Also, be careful to avoid hot-plugging. Hot-plugging occurs when an active voltage supply is instantly connected or switched to the input of the converter. Hot-plugging results in very fast input ramp rates and is not recommended. Finally, for more information, refer to Linear Application Note 88, which discusses voltage overstress that can occur when inductive source impedance is hot-plugged to an input pin bypassed by ceramic capacitors.

Output Power Good

The power good circuits operate properly as long as either V_{IN} or BIAS is above 1.3V . When the LT8494's output voltage is above 92% of the regulation voltage, which refers to the FB pin voltage being above 1.1V (typical), the output voltage is considered good and the open-drain

PG pin becomes high impedance and is typically pulled high with an external resistor. Otherwise, the internal pull-down device will pull the PG pin low. To prevent glitches, the power good function has around 46mV of hysteresis on the FB pin.

As shown in Figure 2, the PG pin is also actively pulled low during several fault conditions: The SWEN pin is below 1V , thermal shutdown, or V_{IN} and BIAS are both under 2.4V .

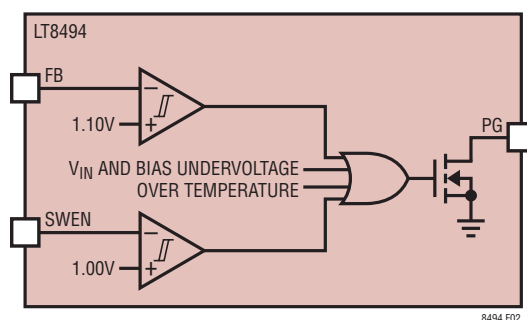

Figure 2. Power Good Function

Enabling the Switching Regulator

The SWEN pin is used to enable or disable the switching regulator. The rising threshold of SWEN is typically 1V , with 30mV of hysteresis. The switching regulator is disabled by driving the SWEN pin below this threshold which deactivates the NPN power switch. The switching regulator is enabled by driving SWEN pin above its threshold. Before active switching begins, the soft-start capacitor will be quickly discharged then slowly charged causing a gradual startup of the regulator. SWEN can be connected to V_{IN} if always on operation is desired, although some current may flow into the SWEN pin (see Typical Performance Characteristics) increasing overall bias current of the system.

By connecting a resistor divider from V_{IN} to SWEN (see Figure 3), the LT8494 will be programmed to disable the switching regulator when V_{IN} drops below a desired threshold. Typically, this threshold is used in situations where the input supply is current limited, or has a relatively high source resistance. A switching regulator draws constant power from the source, so source

APPLICATIONS INFORMATION

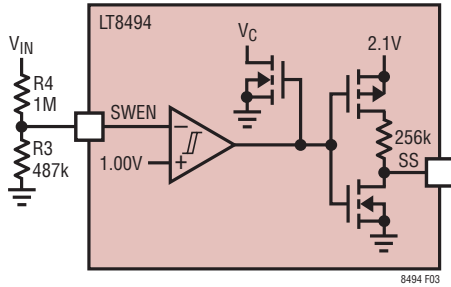

Figure 3. V_{IN} Undervoltage Lockout

current increases as source voltage drops. This looks like a negative resistance load to the source and can cause the source to current limit or latch low under low source voltage conditions. The input UVLO prevents the regulator from operating at source voltages where the problems might occur.

As shown in Figure 3, by connecting a resistor divider from the V_{IN} pin to the SWEN pin, the falling undervoltage lockout threshold is set to:

$$V_{IN(UVLO)} = \frac{R3 + R4}{R3} \cdot 0.97V$$

From the previous equation, the resistor divider shown in Figure 3 gives the V_{IN} pin a falling undervoltage lockout threshold of 2.96V. When V_{IN} is below this threshold, the switching regulation is disabled and the SS pin starts to discharge. After choosing the value of R3, for example, R4 can be calculated using:

$$R4 = R3 \cdot \left(\frac{V_{IN(UVLO)}}{0.97} - 1 \right) \Omega$$

High Temperature Considerations

For higher ambient temperatures, care should be taken in the layout of the PCB to ensure good heat sinking of the LT8494. The exposed pad on the bottom of the package must be soldered to a ground plane. This ground should be tied to large copper layers below with thermal vias; these layers will spread heat dissipated by the LT8494. Placing additional vias can reduce thermal resistance further. The maximum load current should be derated as the ambient temperature approaches the maximum junction rating. Power dissipation within the LT8494 is estimated by calculating the total power loss from an efficiency

measurement and subtracting the diode loss, FB resistor loss and inductor loss. The die temperature is calculated by multiplying the LT8494 power dissipation by the thermal resistance from junction to ambient.

The power switch and its driver dissipate the most power in the LT8494 (see Block Diagram). Higher switch current, duty cycle and output voltage result in higher die temperature. Power loss in the power switch driver also increases with higher input supply voltage. The PSD is supplied by the lowest suitable voltage on V_{IN} and BIAS. Connecting BIAS to a low voltage supply, often V_{OUT} , can reduce the maximum die temperature of the LT8494 (see Automatic Power Supply Selection section).

Also note that leakage current into the SWEN and FB pins increases at high junction temperatures (see Typical Performance Characteristics). The potential leakage current should be considered when choosing high value resistors connected to those pins.

Thermal Lockout: If the die temperature reaches approximately 165°C, the part will go into thermal lockout and the chip will be reset. The part will be enabled again when the die temperature has dropped by ~5°C (nominal). During thermal lockout, the PG pin is actively pulled low, see the Output Power Good section for more details.

Fault Tolerance

The LT8494 is designed to tolerate single fault conditions in the TSSOP package. Shorting two adjacent pins together or leaving one single pin floating does not raise V_{OUT} or cause damage to the LT8494 regulator.

Table 3 and Table 4 show the effects that result from shorting adjacent pins and from a floating pin, respectively. NC pins 4, 9, 17, and 19 must remain floating on the PCB to ensure fault tolerance. NC pins 5 and 15 are not connected to internal circuitry and can either be floated or grounded on the PCB without effecting the fault tolerance. It is recommended that the remaining NC pins (6, 11 and 13) also remain floating on the PCB for best fault tolerance. Table 3 assumes that all NC pins are floating. For the best fault tolerance to inadvertent adjacent pin shorts, the BIAS pin must be tied to something higher than 1.230V or to the output to avoid overvoltage during a short from FB to BIAS.

APPLICATIONS INFORMATION

Table 3. Effects of Pin Shorts (TSSOP)

PIN NAMES	PIN #	EFFECT ON OUTPUT
FB/BIAS	1/2	Output voltage will fall to approximately 1.202V if BIAS is connected to the output.
PG/SS	7/8	No effect or output will fall below regulation.

Table 4. Effects of Floating Pins (TSSOP)

PIN NAME	PIN #	EFFECT ON OUTPUT
BIAS	1	Depending on the V_{IN} voltage and the circuit topology, floating this pin will degrade de-vice performance or the output will fall below regulation.
FB	2, 3	No effect if the other FB pad is soldered.
PG	7	No effect on output.
SS	8	No effect after part has started. Can potentially lead to an increase of inrush current during start-up.
RT	10	Output may fall below regulation.
SWEN	12	Enable state of the pin becomes undefined. Output will not exceed regulation voltage.
GND	14	No effect if Exposed Pad is soldered.
GND	16	No effect on output.
V_{IN}	18	Depending on the BIAS voltage and the circuit topology, floating this pin will degrade device performance or the output will fall below regulation.
SW	10	Output will fall below regulation voltage.
Exposed Pad	21	Output maintains regulation, but potential degradation of device performance.

Layout Hints

As with all high frequency switchers, when considering layout, care must be taken to achieve optimal electrical, thermal and noise performance. One will not get advertised performance with a careless layout. For maximum efficiency, switch rise and fall times are typically in the 5ns to 10ns range. To prevent noise, both radiated and conducted, the high speed switching current path, shown in Figures 4 and 5, must be kept as short as possible. This is implemented in the suggested PCB layouts in Figures 6

and 7. Shortening this path will also reduce the parasitic trace inductance. At switch-off, this parasitic inductance produces a flyback spike across the LT8494 switch. When operating at higher currents and output voltages, with poor layout, this spike can generate voltages across the LT8494 that may exceed its absolute maximum rating. A ground plane should also be used under the switcher circuitry to prevent interplane coupling and overall noise. The FB components should be kept as far away as practical from the switch node. The ground for these components should be separated from the switch current path. Failure to do so can result in poor stability or subharmonic oscillation.

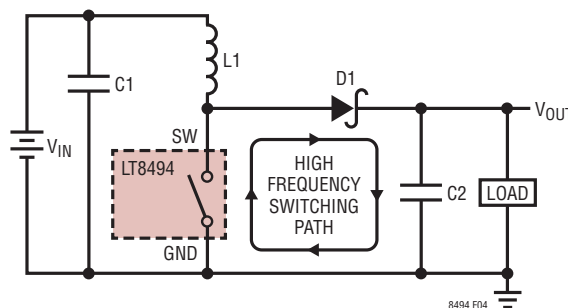

Figure 4. High Speed Chopped Switching Path for Boost Topology

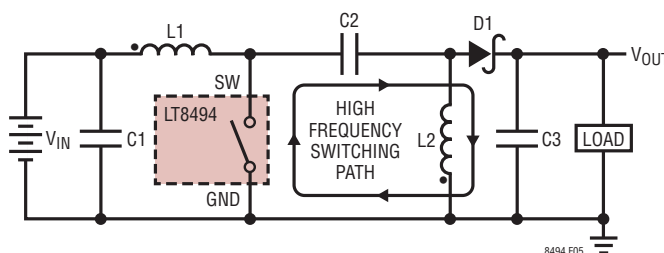

Figure 5. High Speed Chopped Switching Path for SEPIC Topology

APPLICATIONS INFORMATION

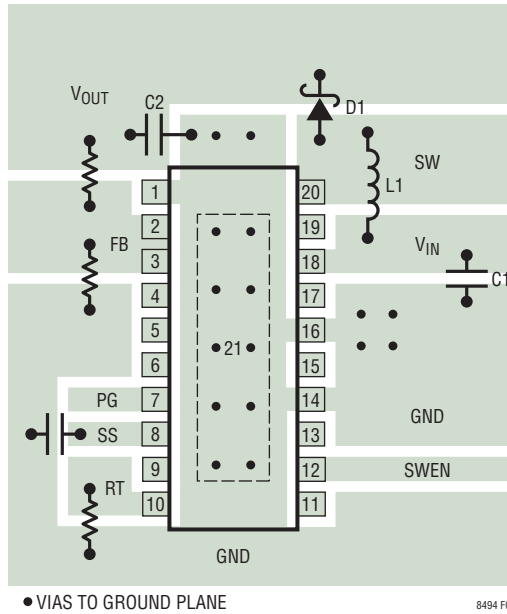

Figure 6. Suggested Component Placement for Boost Topology Using TSSOP Package. Pin 21 (Exposed Pad) Must Be Soldered Directly to the Local Ground Plane for Adequate Thermal Performance. Multiple Vias to Additional Ground Planes Will Improve Thermal Performance

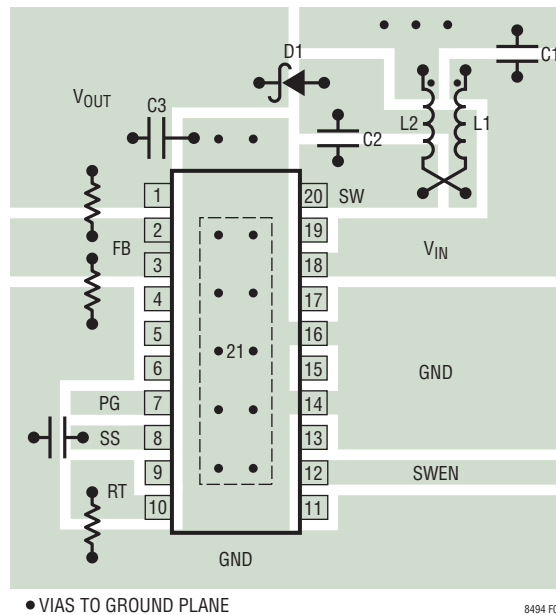
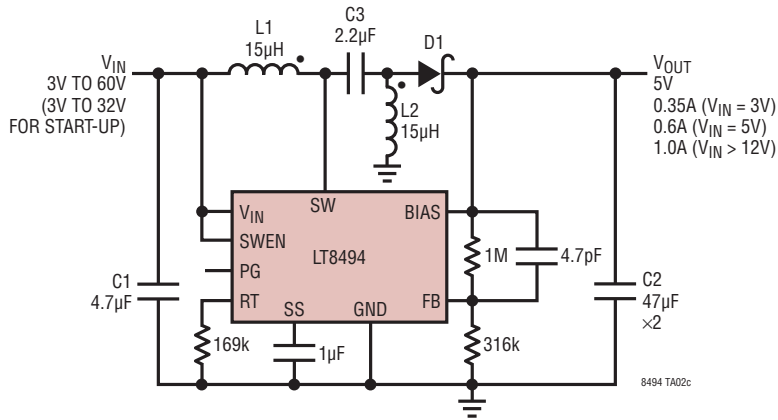

Figure 7. Suggested Component Placement for SEPIC Topology Using TSSOP Package. Pin 21 (Exposed Pad) Must Be Soldered Directly to the Local Ground Plane for Adequate Thermal Performance. Multiple Vias to Additional Ground Planes Will Improve Thermal Performance

TYPICAL APPLICATIONS

450kHz, 5V Output SEPIC Converter (Same as Front Page Application)



- C1: 4.7µF, 100V, X5R, 1206
- C3: 2.2µF, 100V, X5R, 1206
- C2: TAIYO YUDEN, EMK325BJ476MM-T
- D1: ONSEMI MBRA2H100
- L1, L2: COILTRONICS DRQ125-150-R

750kHz, 16V to 32V Input, 48V Output, 0.5A Boost Converter

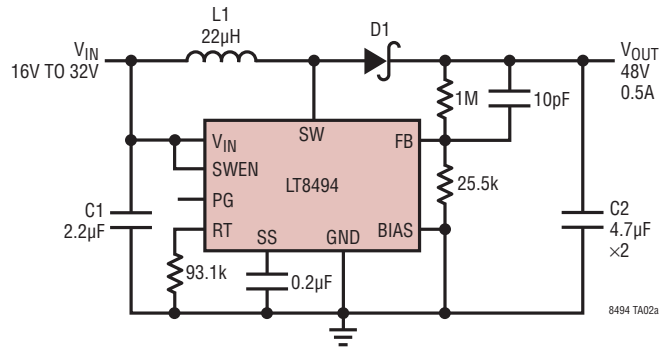

- C1: 2.2µF, 50V, X5R, 1206
- C2: 4.7µF, 100V, X7R, 1210
- D1: ONSEMI MBRA2H100
- L1: WURTH LHMI 74437349220

Efficiency, $V_{IN} = 24V$

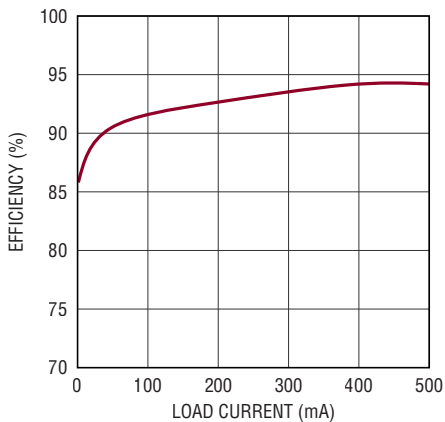

Transient Response with 400mA to 500mA Output Load Step

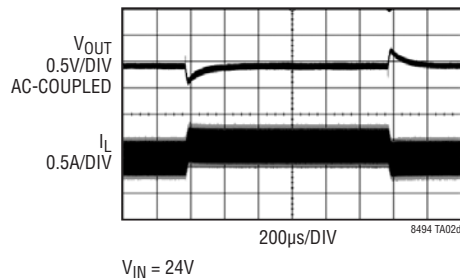

Start-Up Waveforms

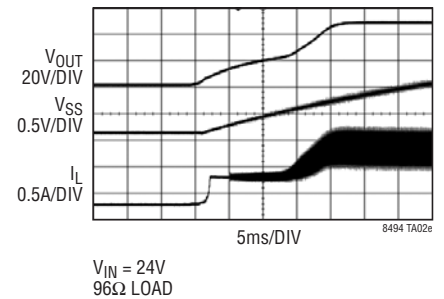

TYPICAL APPLICATIONS

Wide Input and Output Range SEPIC Converter with Charge Pump Switches at 400kHz

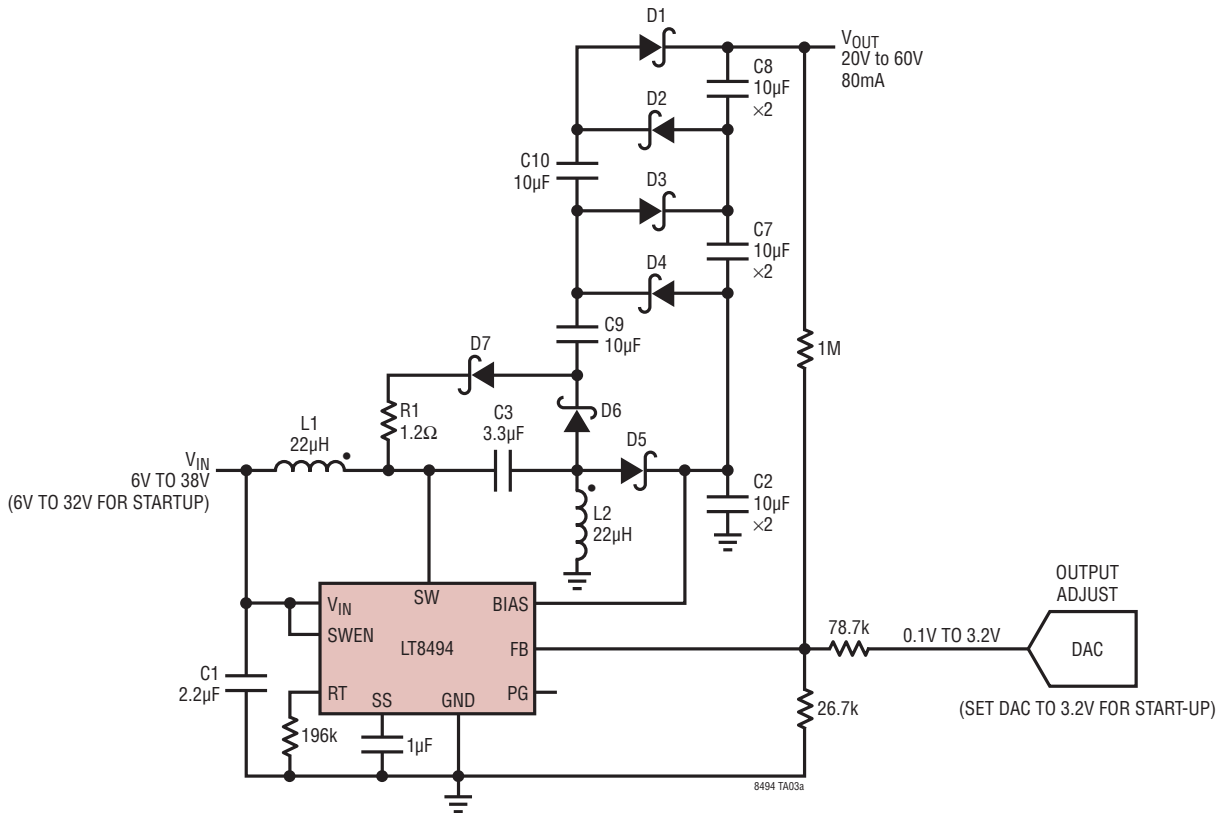

- L1, L2: COILCRAFT MSD1260T-223ML
 C1: 2.2µF, 50V, X5R, 1206
 C2, C7-C10: TAIYO YUDEN GMK325C7106KMHT, 10µF 35V, X7S, 1210
 C3: 3.3µF, 100V, X7R, 1210
 D1-D4: FAIRCHILD 0540
 D5-D7: ON-SEMI MBRA2H100
 R1: 1.2Ω, 0.5W, SMD, 2010

TYPICAL APPLICATIONS

Li-Ion to 12V, Low Quiescent Current Boost at 650kHz

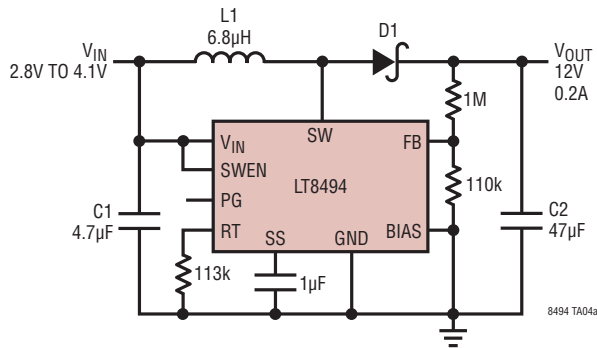

C1: 4.7µF, 6.3V, X7R, 1206
 C2: 47µF, 16V, X5R, 1210
 D1: ONSEMI MBRM120LT1G
 L1: WURTH LHMI 74437346068

Efficiency, $V_{IN} = 3.3V$

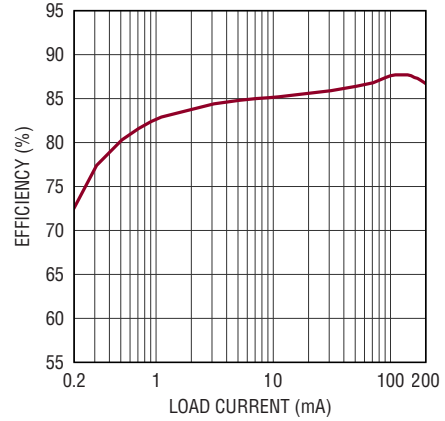

Low Quiescent Current, 5V to 300V, 250kHz Flyback Converter

DANGER HIGH VOLTAGE!
 Operation by High Voltage Trained Personnel Only

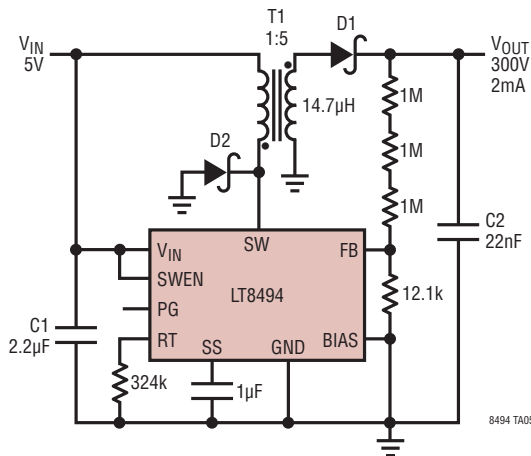

*KEEP MAXIMUM OUTPUT POWER BELOW 0.6W

C1: 2.2µF, 25V, X5R, 1206
 C2: TDK C3225CH2J223K
 D1: VISHAY GSD2004S DUAL DIODE CONNECTED IN SERIES
 D2: ON SEMICONDUCTOR MBRA2H100
 T1: WURTH-FLEX FLEXIBAL TRANSFORMER 749196121

Start-Up Waveforms

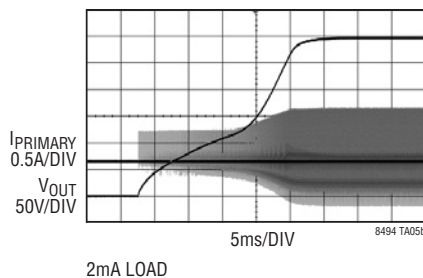

Switching Waveforms

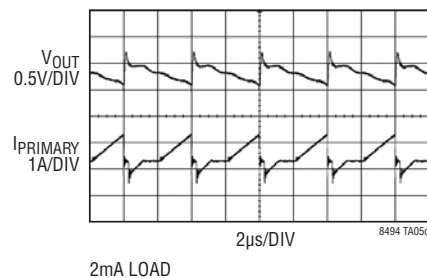

TYPICAL APPLICATIONS

1.5MHz, 12V Output SEPIC Converter

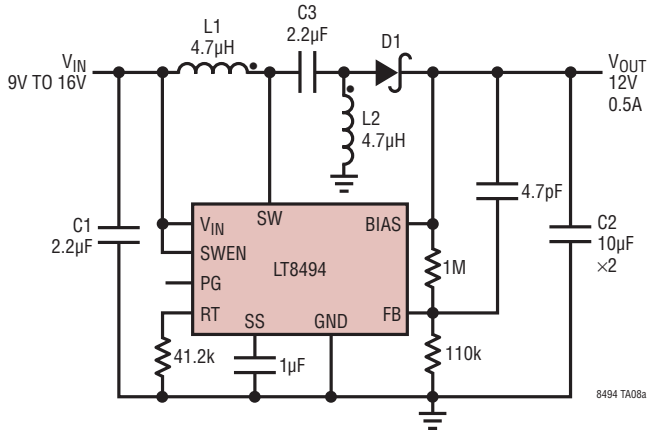

- C1, C3: 2.2µF, 50V, X5R, 1206
- C2: TAIYO YUDEN TMK325BJ106MM
- D1: DENTRAL SEMI CMMSH2-40
- L1, L2: COILTRONICS DRQ74-4R7

Efficiency, $V_{IN} = 12V$

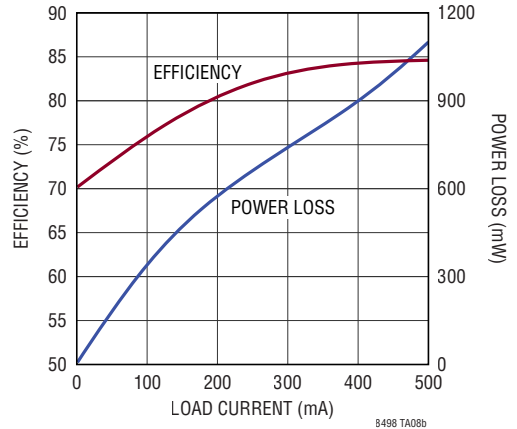

PACKAGE DESCRIPTION

Please refer to <http://www.linear.com/product/LT8494#packaging> for the most recent package drawings.

UF Package
20-Lead Plastic QFN (4mm × 4mm)
 (Reference LTC DWG # 05-08-1710 Rev A)

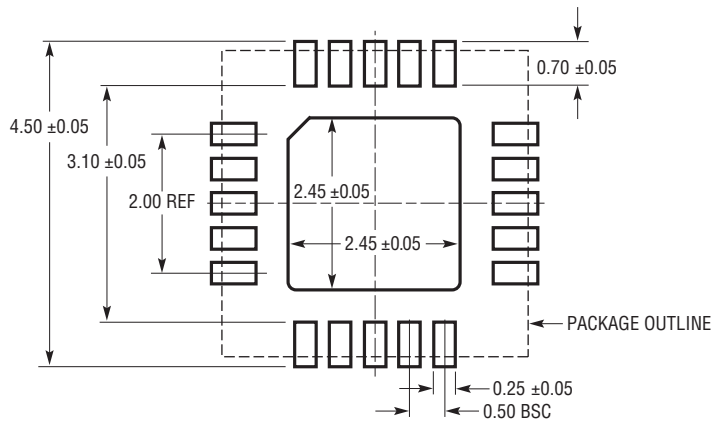

RECOMMENDED SOLDER PAD PITCH AND DIMENSIONS
 APPLY SOLDER MASK TO AREAS THAT ARE NOT SOLDERED

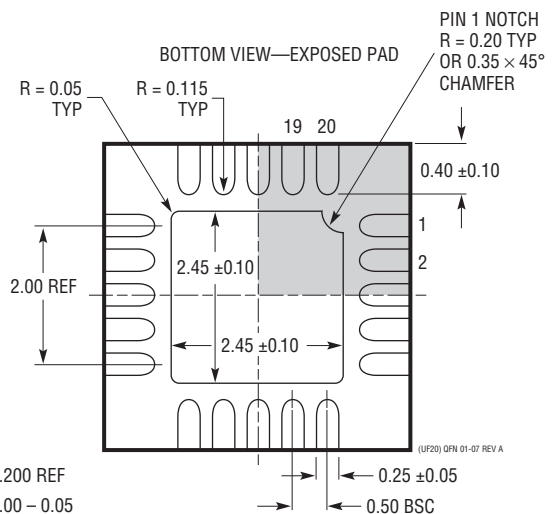
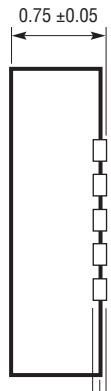
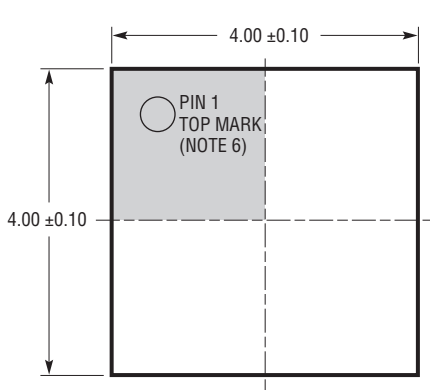

- NOTE:
1. DRAWING IS PROPOSED TO BE MADE A JEDEC PACKAGE OUTLINE MO-220 VARIATION (WGGD-1)—TO BE APPROVED
 2. DRAWING NOT TO SCALE
 3. ALL DIMENSIONS ARE IN MILLIMETERS
 4. DIMENSIONS OF EXPOSED PAD ON BOTTOM OF PACKAGE DO NOT INCLUDE MOLD FLASH. MOLD FLASH, IF PRESENT, SHALL NOT EXCEED 0.15mm ON ANY SIDE
 5. EXPOSED PAD SHALL BE SOLDER PLATED
 6. SHADED AREA IS ONLY A REFERENCE FOR PIN 1 LOCATION ON THE TOP AND BOTTOM OF PACKAGE

PACKAGE DESCRIPTION

Please refer to <http://www.linear.com/product/LT8494#packaging> for the most recent package drawings.

FE Package
20-Lead Plastic TSSOP (4.4mm)
 (Reference LTC DWG # 05-08-1663 Rev L)
Exposed Pad Variation CB

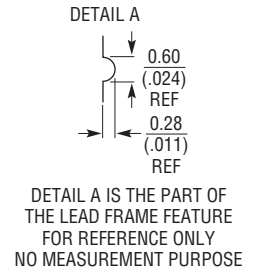
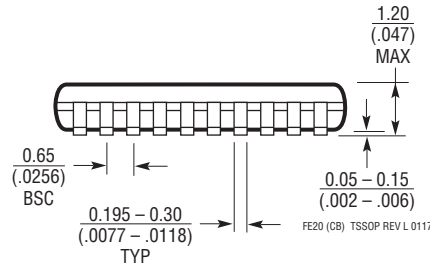
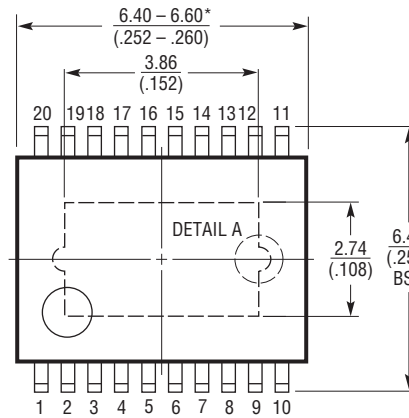
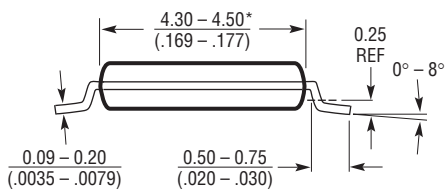
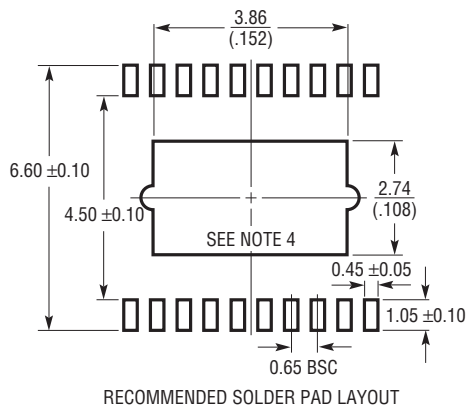

NOTE:

1. CONTROLLING DIMENSION: MILLIMETERS
 2. DIMENSIONS ARE IN $\frac{\text{MILLIMETERS}}{\text{(INCHES)}}$
 3. DRAWING NOT TO SCALE
 4. RECOMMENDED MINIMUM PCB METAL SIZE FOR EXPOSED PAD ATTACHMENT
- *DIMENSIONS DO NOT INCLUDE MOLD FLASH. MOLD FLASH SHALL NOT EXCEED 0.150mm (.006") PER SIDE

REVISION HISTORY

REV	DATE	DESCRIPTION	PAGE NUMBER
A	06/17	Clarified input conditions on top application	19, 24

TYPICAL APPLICATION

450kHz, Wide Input Range 12V Output SEPIC Converter

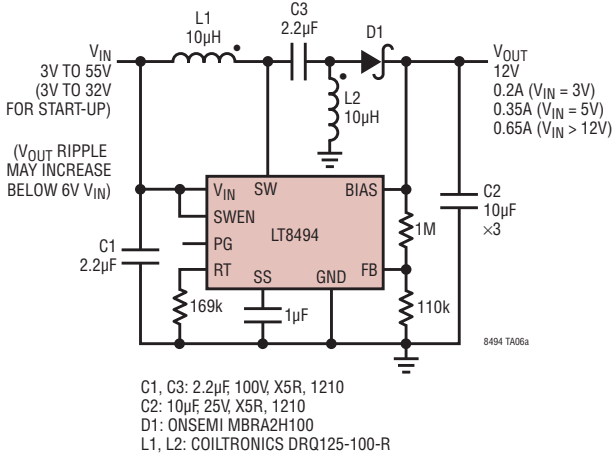

Efficiency

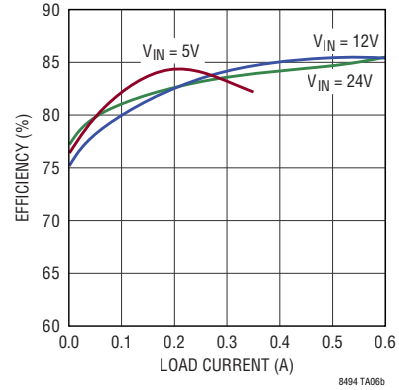

No-Load Supply Current

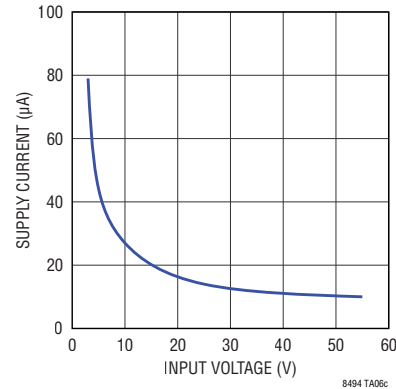

RELATED PARTS

PART NUMBER	DESCRIPTION	COMMENTS
LT8495	70V, 2A Boost/SEPIC 1.5MHz High Efficiency DC/DC Converter with POR and Watchdog Timer	V_{IN} : 2.5V to 32V, $V_{OUT(MAX)}$ = 70V, I_Q = 9 μ A, I_{SD} < 1 μ A, 4mm \times 4mm QFN20, TSSOP-20E Packages
LT3580	42V, 2A Boost/Inverting 2.5MHz High Efficiency DC/DC Converter	V_{IN} : 2.5V to 32V, $V_{OUT(MAX)}$ = \pm 40V, I_Q = 1mA, I_{SD} < 1 μ A, 3mm \times 3mm DFN-8, MSOP-8E Packages
LT8580	65V, 1A Boost/Inverting DC/DC Converter	V_{IN} : 2.55V to 40V, $V_{OUT(MAX)}$ = \pm 60V, I_Q = 1.2mA, I_{SD} < 1 μ A, 3mm \times 3mm DFN-8, MSOP-8E Packages
LT8570/ LT8570-1	65V, 500mA/250mA Boost/Inverting DC/DC Converter	V_{IN} : 2.55V to 40V, $V_{OUT(MAX)}$ = \pm 60V, I_Q = 1.2mA, I_{SD} < 1 μ A, 3mm \times 3mm DFN-8, MSOP-8E Packages
LT8582	40V, Dual 3A, 2.5MHz High Efficiency Boost Converter	V_{IN} : 2.5V to 40V, $V_{OUT(MAX)}$ = \pm 40V, I_Q = 2.8mA, I_{SD} < 1 μ A, 7mm \times 4mm DFN-24 Package
LT8471	40V, Dual 3A, Multitopology High Efficiency DC/DC Converter	V_{IN} : 2.6V to 50V, $V_{OUT(MAX)}$ = \pm 45V, I_Q = 2.4mA, I_{SD} < 1 μ A, TSSOP-20E Package
LT3581	40V, 3.3A, 2.5MHz High Efficiency Boost Converter	V_{IN} : 2.5V to 40V, $V_{OUT(MAX)}$ = \pm 40V, I_Q = 1mA, I_{SD} < 1 μ A, 4mm \times 3mm DFN-14, MSOP-16E Packages
LT8582	40V, Dual 3A Boost, Inverter, SEPIC, 2.5MHz High Efficiency Boost Converter	V_{IN} : 2.5V to 40V, $V_{OUT(MAX)}$ = \pm 40V, I_Q = 2.1mA, I_{SD} < 1 μ A, 7mm \times 4mm DFN-24 Package
LT3579/ LT3579-1	40V, 3.3A Boost, Inverter, SEPIC, 2.5MHz High Efficiency Boost Converter	V_{IN} : 2.5V to 40V, $V_{OUT(MAX)}$ = \pm 40V, I_Q = 1mA, I_{SD} < 1 μ A, 4mm \times 5mm QFN-20, TSSOP-20E Packages

8494fa

Looking for pricing, stock, or lifecycle information?

Click below to explore more details on WIN SOURCE:

 [View LT8494IUF#PBF on WIN SOURCE](#)

 [Linear Technology](#) Information

Optimize Your Supply Chain with WIN SOURCE Solutions

-  Global Sourcing Solution
-  Obsolete Management
-  Cost Control Management
-  Shortage Management
-  Alternative Solution
-  Excess Inventory Management