



**THE DATASHEET OF  
LT8610AHMSE#TRPBF**



### FEATURES

- **LT8610 Feature Set, Plus:**
  - 3.5A Maximum Output Current**
  - Fast 30ns Minimum Switch-On Time**
  - Improved Burst Mode Efficiency (LT8610AB Only)**
  - Improved EMI**
- **Wide Input Voltage Range: 3.4V to 42V**
- **Ultralow Quiescent Current Burst Mode<sup>®</sup> Operation:**
  - 2.5 $\mu$ A I<sub>Q</sub> Regulating 12V<sub>IN</sub> to 3.3V<sub>OUT</sub>**
- **Fixed Output Voltages: 3.3V, 5V**
- **Output Ripple < 10mV<sub>P-P</sub> (LT8610A Only)**
- **High Efficiency Synchronous Operation:**
  - 95% Efficiency at 1A, 5V<sub>OUT</sub> from 12V<sub>IN</sub>**
  - 93% Efficiency at 1A, 3.3V<sub>OUT</sub> from 12V<sub>IN</sub>**
- **Low Dropout Under All Conditions: 200mV at 1A**
- **Safely Tolerates Inductor Saturation in Overload**
- **Adjustable and Synchronizable Frequency:**
  - 200kHz to 2.2MHz**
- **Accurate 1V Enable Pin Threshold**
- **Output Soft-Start and Tracking**
- **Small Thermally Enhanced 16-Lead MSOP Package**

### APPLICATIONS

- Automotive and Industrial Supplies
- GSM Power Supplies

### DESCRIPTION

The **LT<sup>®</sup>8610A/LT8610AB** series are compact, high efficiency, high speed synchronous monolithic step-down switching regulators that consume only 2.5 $\mu$ A of quiescent current. Compared to the LT8610, they have higher maximum output currents of 3.5A and a faster minimum switch-on time of 30ns. The LT8610A has the same low ripple burst mode performance of the LT8610, while the LT8610AB has even higher light load efficiency.

The other features of the LT8610 remain unchanged in the LT8610A/LT8610AB series. A SYNC pin allows synchronization to an external clock. The EN/UV pin has an accurate 1V threshold for V<sub>IN</sub> undervoltage lockout or shut down. A capacitor on the TR/SS pin programs the output voltage ramp rate during startup. The PG flag signals when V<sub>OUT</sub> is within  $\pm$ 9% of the programmed output voltage as well as fault conditions.

	OUTPUT CURRENT	MINIMUM ON TIME	1mA LOAD EFFICIENCY**
LT8610*	2.5A	50ns	82%
LT8610A	3.5A	30ns	82%
LT8610AB	3.5A	30ns	91%

\*See LT8610 data sheet. \*\*V<sub>IN</sub> = 12V, V<sub>OUT</sub> = 3.3V, L = 4.7 $\mu$ H

LT, LT, LTC, LTM, Burst Mode, Linear Technology and the Linear logo are registered trademarks of Linear Technology Corporation. All other trademarks are the property of their respective owners.

### TYPICAL APPLICATION

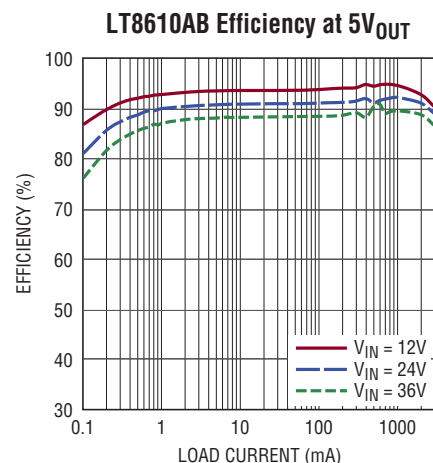
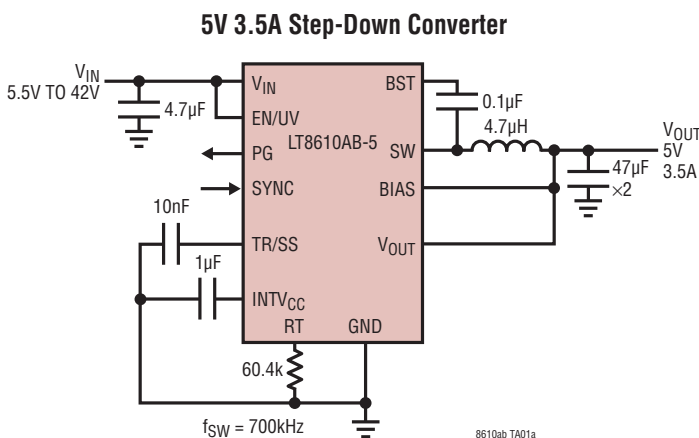

# LT8610A/LT8610AB Series

## ABSOLUTE MAXIMUM RATINGS (Note 1)

$V_{IN}$ , EN/UV, PG	42V
BIAS	30V
BST Pin Above SW Pin	4V
FB, TR/SS, RT, INTV <sub>CC</sub>	4V
$V_{OUT}$ , SYNC Voltage	6V

## Operating Junction Temperature Range (Note 2)

LT8610AE/LT8610ABE	-40 to 125°C
LT8610AI/LT8610ABI	-40 to 125°C
LT8610AH/LT8610ABH	-40 to 150°C
Storage Temperature Range	-65 to 150°C

## PIN CONFIGURATION

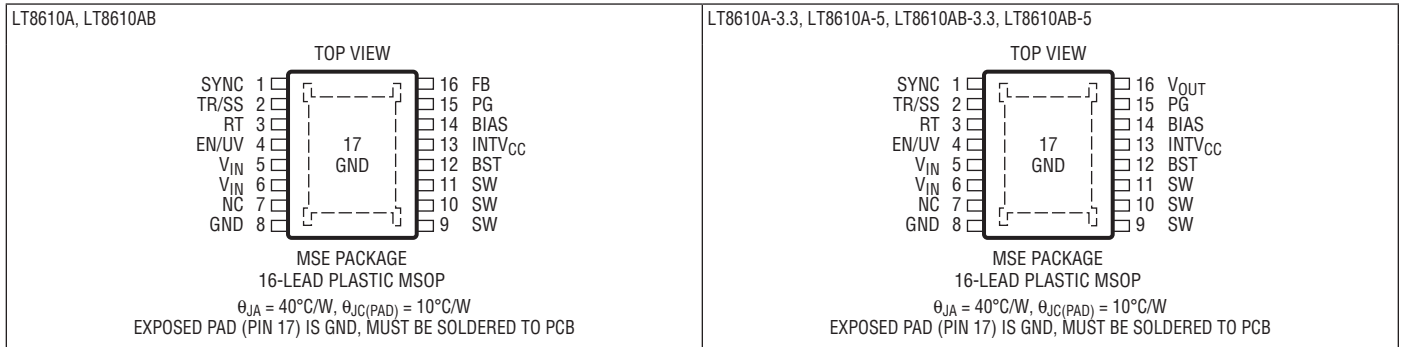

## ORDER INFORMATION

LEAD FREE FINISH	TAPE AND REEL	PART MARKING*	PACKAGE DESCRIPTION	TEMPERATURE RANGE
LT8610AEMSE#PBF	LT8610AEMSE#TRPBF	8610A	16-Lead Plastic MSOP	-40°C to 125°C
LT8610AEMSE-3.3#PBF	LT8610AEMSE-3.3#TRPBF	610A33	16-Lead Plastic MSOP	-40°C to 125°C
LT8610AEMSE-5#PBF	LT8610AEMSE-5#TRPBF	8610A5	16-Lead Plastic MSOP	-40°C to 125°C
LT8610AIMSE#PBF	LT8610AIMSE#TRPBF	8610A	16-Lead Plastic MSOP	-40°C to 125°C
LT8610AIMSE-3.3#PBF	LT8610AIMSE-3.3#TRPBF	610A33	16-Lead Plastic MSOP	-40°C to 125°C
LT8610AIMSE-5#PBF	LT8610AIMSE-5#TRPBF	8610A5	16-Lead Plastic MSOP	-40°C to 125°C
LT8610AHMSE#PBF	LT8610AHMSE#TRPBF	8610A	16-Lead Plastic MSOP	-40°C to 150°C
LT8610AHMSE-3.3#PBF	LT8610AHMSE-3.3#TRPBF	610A33	16-Lead Plastic MSOP	-40°C to 150°C
LT8610AHMSE-5#PBF	LT8610AHMSE-5#TRPBF	8610A5	16-Lead Plastic MSOP	-40°C to 150°C
LT8610ABEMSE#PBF	LT8610ABEMSE#TRPBF	8610AB	16-Lead Plastic MSOP	-40°C to 125°C
LT8610ABEMSE-3.3#PBF	LT8610ABEMSE-3.3#TRPBF	10AB33	16-Lead Plastic MSOP	-40°C to 125°C
LT8610ABEMSE-5#PBF	LT8610ABEMSE-5#TRPBF	610AB5	16-Lead Plastic MSOP	-40°C to 125°C
LT8610ABIMSE#PBF	LT8610ABIMSE#TRPBF	8610AB	16-Lead Plastic MSOP	-40°C to 125°C
LT8610ABIMSE-3.3#PBF	LT8610ABIMSE-3.3#TRPBF	10AB33	16-Lead Plastic MSOP	-40°C to 125°C
LT8610ABIMSE-5#PBF	LT8610ABIMSE-5#TRPBF	610AB5	16-Lead Plastic MSOP	-40°C to 125°C
LT8610ABHMSE#PBF	LT8610ABHMSE#TRPBF	8610AB	16-Lead Plastic MSOP	-40°C to 150°C
LT8610ABHMSE-3.3#PBF	LT8610ABHMSE-3.3#TRPBF	10AB33	16-Lead Plastic MSOP	-40°C to 150°C
LT8610ABHMSE-5#PBF	LT8610ABHMSE-5#TRPBF	610AB5	16-Lead Plastic MSOP	-40°C to 150°C

Consult LTC Marketing for parts specified with wider operating temperature ranges. \*The temperature grade is identified by a label on the shipping container. Consult LTC Marketing for information on non-standard lead based finish parts.

For more information on lead free part marking, go to: <http://www.linear.com/leadfree/>

For more information on tape and reel specifications, go to: <http://www.linear.com/tapeandreeel/>

8610abfa

# LT8610A/LT8610AB Series

## ELECTRICAL CHARACTERISTICS

The ● denotes the specifications which apply over the full operating temperature range, otherwise specifications are at  $T_A = 25^\circ\text{C}$ .

PARAMETER	CONDITIONS		MIN	TYP	MAX	UNITS
Minimum Input Voltage	(Note 4)	●		2.9	3.4	V
$V_{IN}$ Quiescent Current	$V_{EN/UV} = 0V$	●		1.0	3	$\mu\text{A}$
		●		1.0	8	$\mu\text{A}$
	$V_{EN/UV} = 2V$ , Not Switching, $V_{SYNC} = 0V$	●		1.7	4	$\mu\text{A}$
		●		1.7	10	$\mu\text{A}$
	$V_{EN/UV} = 2V$ , Not Switching, $V_{SYNC} = 2V$			0.26	0.5	mA
$V_{IN}$ Current in Regulation	$V_{OUT} = 0.97V$ , $V_{IN} = 6V$ , Output Load = $100\mu\text{A}$ (LT8610A)	●		24	50	$\mu\text{A}$
	$V_{OUT} = 0.97V$ , $V_{IN} = 6V$ , Output Load = $1\text{mA}$ (LT8610A)	●		210	350	$\mu\text{A}$
	$V_{OUT} = 0.97V$ , $V_{IN} = 6V$ , Output Load = $100\mu\text{A}$ (LT8610AB)	●		24	50	$\mu\text{A}$
	$V_{OUT} = 0.97V$ , $V_{IN} = 6V$ , Output Load = $1\text{mA}$ (LT8610AB)	●		210	350	$\mu\text{A}$
$V_{IN}$ Current in Regulation	$V_{OUT} = 3.3V$ , $V_{IN} = 8V$ , Output Load = $100\mu\text{A}$ (LT8610A-3.3)	●		60	120	$\mu\text{A}$
	$V_{OUT} = 3.3V$ , $V_{IN} = 8V$ , Output Load = $1\text{mA}$ (LT8610A-3.3)	●		540	900	$\mu\text{A}$
	$V_{OUT} = 3.3V$ , $V_{IN} = 8V$ , Output Load = $100\mu\text{A}$ (LT8610AB-3.3)	●		55	100	$\mu\text{A}$
	$V_{OUT} = 3.3V$ , $V_{IN} = 8V$ , Output Load = $1\text{mA}$ (LT8610AB-3.3)	●		500	800	$\mu\text{A}$
	$V_{OUT} = 5V$ , $V_{IN} = 8V$ , Output Load = $100\mu\text{A}$ (LT8610A-5)	●		100	180	$\mu\text{A}$
	$V_{OUT} = 5V$ , $V_{IN} = 8V$ , Output Load = $1\text{mA}$ (LT8610A-5)	●		790	1200	$\mu\text{A}$
	$V_{OUT} = 5V$ , $V_{IN} = 8V$ , Output Load = $100\mu\text{A}$ (LT8610AB-5)	●		80	150	$\mu\text{A}$
	$V_{OUT} = 5V$ , $V_{IN} = 8V$ , Output Load = $1\text{mA}$ (LT8610AB-5)	●		730	1100	$\mu\text{A}$
Feedback Reference Voltage (LT8610A/LT8610AB)	$V_{IN} = 6V$ , $I_{LOAD} = 0.5A$		0.964	0.970	0.976	V
	$V_{IN} = 6V$ , $I_{LOAD} = 0.5A$	●	0.958	0.970	0.982	V
Output Voltage (LT8610A-3.3/LT8610AB-3.3)	$V_{IN} = 8V$ , $I_{LOAD} = 0.5A$		3.28	3.30	3.32	V
	$V_{IN} = 8V$ , $I_{LOAD} = 0.5A$	●	3.26	3.30	3.34	V
Output Voltage (LT8610A-5/LT8610AB-5)	$V_{IN} = 8V$ , $I_{LOAD} = 0.5A$		4.97	5.00	5.03	V
	$V_{IN} = 8V$ , $I_{LOAD} = 0.5A$	●	4.94	5.00	5.06	V
Feedback Voltage Line Regulation (LT8610A/LT8610AB)	$V_{IN} = 4V$ to $42V$ , $I_{LOAD} = 1A$	●		0.004	0.02	%/V
Voltage Line Regulation (LT8610A-3.3/LT8610AB-3.3)	$V_{IN} = 4V$ to $42V$ , $I_{LOAD} = 1A$	●		0.004	0.02	%/V
Voltage Line Regulation (LT8610A-5/LT8610AB-5)	$V_{IN} = 6V$ to $42V$ , $I_{LOAD} = 1A$	●		0.004	0.02	%/V
Feedback Pin Input Current (LT8610A/LT8610AB)	$V_{FB} = 1V$		-20		20	nA
Internal Feedback Resistor Divider (LT8610A-3.3/LT8610AB-3.3)				14.3		$\text{M}\Omega$
Internal Feedback Resistor Divider (LT8610A-5/LT8610AB-5)				12.5		$\text{M}\Omega$
INTV <sub>CC</sub> Voltage	$I_{LOAD} = 0\text{mA}$ , $V_{BIAS} = 0V$		3.23	3.4	3.57	V
	$I_{LOAD} = 0\text{mA}$ , $V_{BIAS} = 3.3V$		3.25	3.29	3.35	V
INTV <sub>CC</sub> Undervoltage Lockout			2.5	2.6	2.7	V
BIAS Pin Current Consumption	$V_{BIAS} = 3.3V$ , $I_{LOAD} = 1A$ , 2MHz			9		mA
Minimum On-Time	$I_{LOAD} = 1A$ , $SYNC = 0V$	●	15	30	45	ns
	$I_{LOAD} = 1A$ , $SYNC = 3.3V$	●	15	30	45	ns
Minimum Off-Time				95	125	ns

# LT8610A/LT8610AB Series

## ELECTRICAL CHARACTERISTICS

The ● denotes the specifications which apply over the full operating temperature range, otherwise specifications are at  $T_A = 25^\circ\text{C}$ .

PARAMETER	CONDITIONS		MIN	TYP	MAX	UNITS
Oscillator Frequency	$R_T = 221\text{k}, I_{\text{LOAD}} = 1\text{A}$	●	180	210	240	kHz
	$R_T = 60.4\text{k}, I_{\text{LOAD}} = 1\text{A}$	●	665	700	735	kHz
	$R_T = 18.2\text{k}, I_{\text{LOAD}} = 1\text{A}$	●	1.85	2.00	2.15	MHz
Top Power NMOS On-Resistance	$I_{\text{SW}} = 1\text{A}$			120		m $\Omega$
Top Power NMOS Current Limit	LT8610A	●	5	6.7	8	A
	LT8610AB	●	5	6.7	8	A
Bottom Power NMOS On-Resistance	$V_{\text{INTVCC}} = 3.4\text{V}, I_{\text{SW}} = 1\text{A}$			65		m $\Omega$
Bottom Power NMOS Current Limit	$V_{\text{INTVCC}} = 3.4\text{V}$		3.4	4.3	5.4	A
SW Leakage Current	$V_{\text{IN}} = 42\text{V}, V_{\text{SW}} = 0\text{V}, 42\text{V}$		-1.5		1.5	$\mu\text{A}$
EN/UV Pin Threshold	EN/UV Rising	●	0.94	1.0	1.06	V
EN/UV Pin Hysteresis				40		mV
EN/UV Pin Current	$V_{\text{EN/UV}} = 2\text{V}$		-20		20	nA
PG Upper Threshold Offset from $V_{\text{FB}}$	$V_{\text{FB}}$ Falling	●	6	9.0	12	%
PG Lower Threshold Offset from $V_{\text{FB}}$	$V_{\text{FB}}$ Rising	●	-12	-9.0	-6	%
PG Hysteresis				1.3		%
PG Leakage	$V_{\text{PG}} = 3.3\text{V}$		-40		40	nA
PG Pull-Down Resistance	$V_{\text{PG}} = 0.1\text{V}$	●		680	2000	$\Omega$
SYNC Threshold	SYNC Falling		0.8	1.1	1.4	V
	SYNC Rising		1.6	2.0	2.4	V
SYNC Pin Current	$V_{\text{SYNC}} = 6\text{V}$		-40		40	nA
TR/SS Source Current		●	1.0	2.0	3.2	$\mu\text{A}$
TR/SS Pull-Down Resistance	Fault Condition, TR/SS = 0.1V			230		$\Omega$

**Note 1:** Stresses beyond those listed under Absolute Maximum Ratings may cause permanent damage to the device. Exposure to any Absolute Maximum Rating condition for extended periods may affect device reliability and lifetime.

**Note 2:** The LT8610AE/LT8610ABE is guaranteed to meet performance specifications from  $0^\circ\text{C}$  to  $125^\circ\text{C}$  junction temperature. Specifications over the  $-40^\circ\text{C}$  to  $125^\circ\text{C}$  operating junction temperature range are assured by design, characterization, and correlation with statistical process controls. The LT8610AI/LT8610ABI is guaranteed over the full  $-40^\circ\text{C}$  to  $125^\circ\text{C}$  operating junction temperature range. The LT8610AH is guaranteed over the full  $-40^\circ\text{C}$  to  $150^\circ\text{C}$  operating junction temperature range. High junction temperatures degrade operating lifetimes. Operating lifetime is derated at junction temperatures greater than  $125^\circ\text{C}$ .

**Note 3:** This IC includes overtemperature protection that is intended to protect the device during overload conditions. Junction temperature will exceed  $150^\circ\text{C}$  when overtemperature protection is active. Continuous operation above the specified maximum operating junction temperature will reduce lifetime.

**Note 4:** For fixed output voltage versions, minimum input voltage will be limited by output voltage.

## TYPICAL PERFORMANCE CHARACTERISTICS

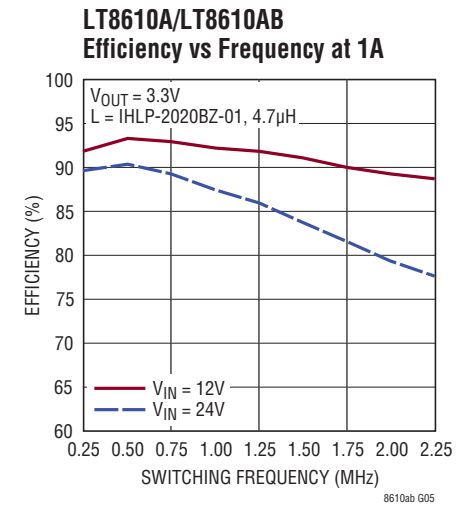
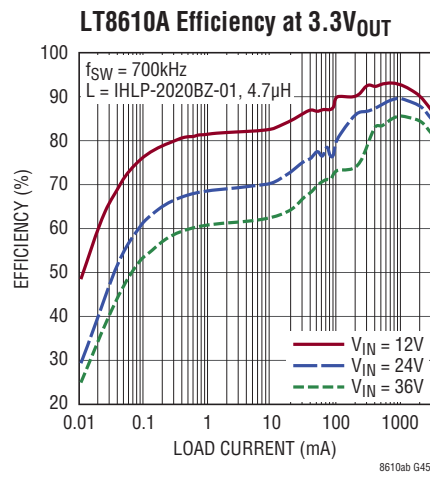
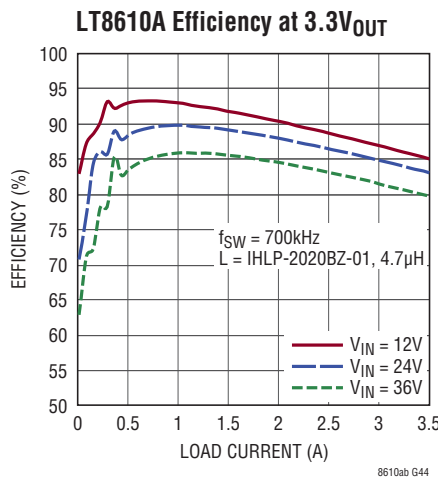
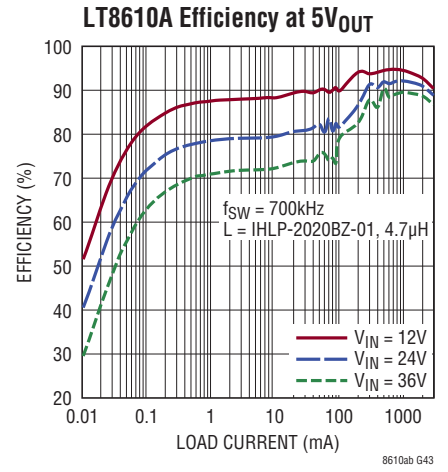
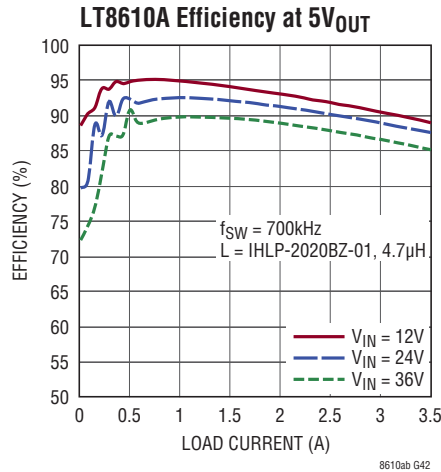
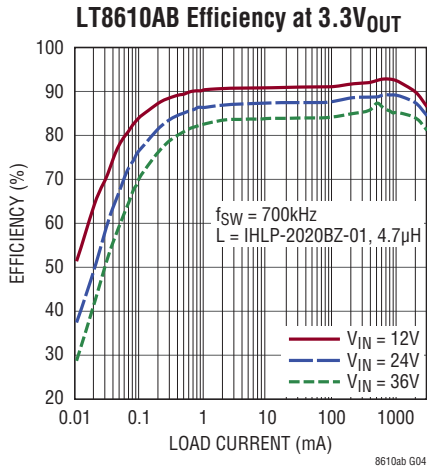
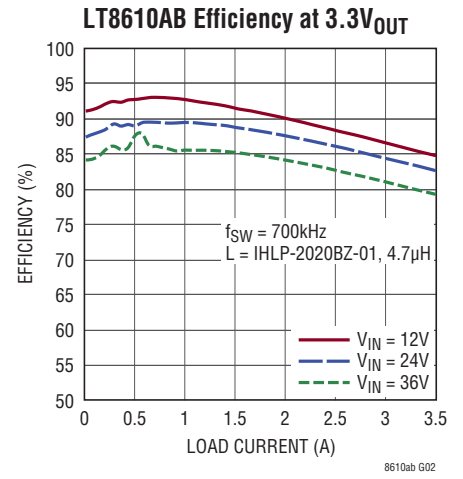
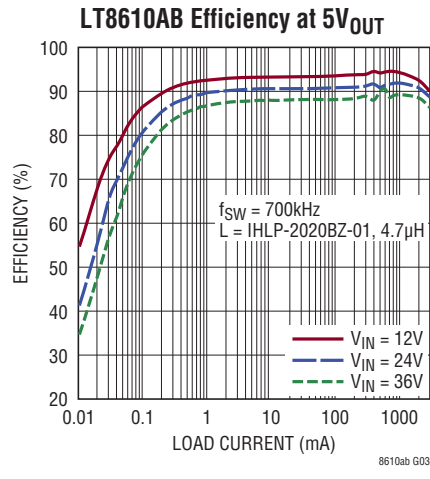
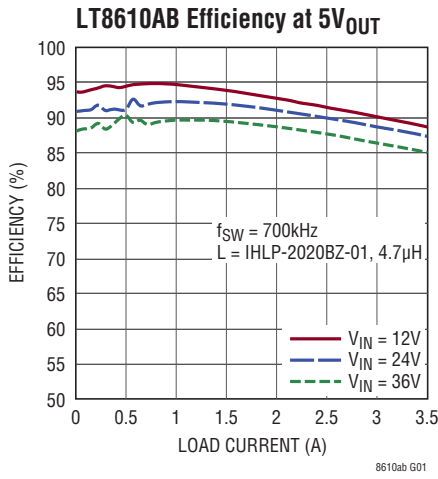

# LT8610A/LT8610AB Series

## TYPICAL PERFORMANCE CHARACTERISTICS

Reference Voltage

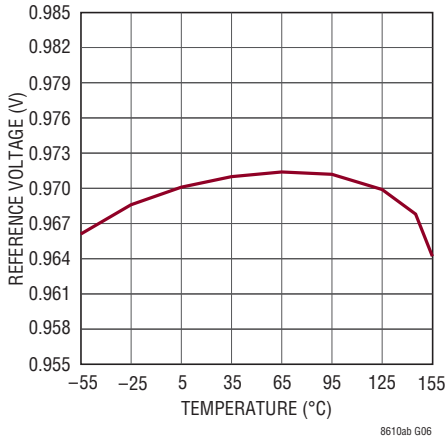

LT8610A-3.3 Output Voltage

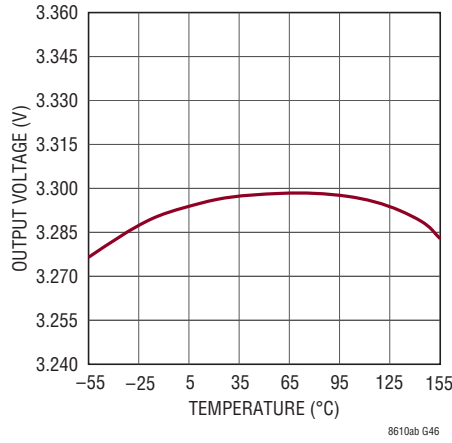

LT8610AB-3.3 Output Voltage

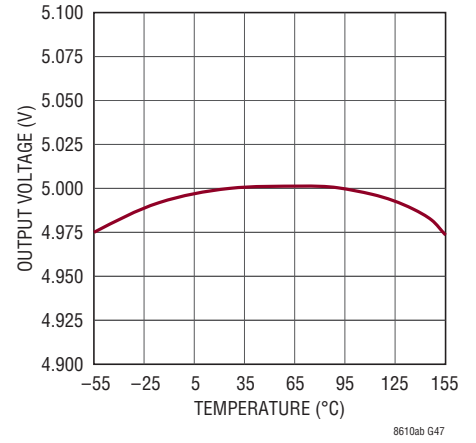

EN Pin Thresholds

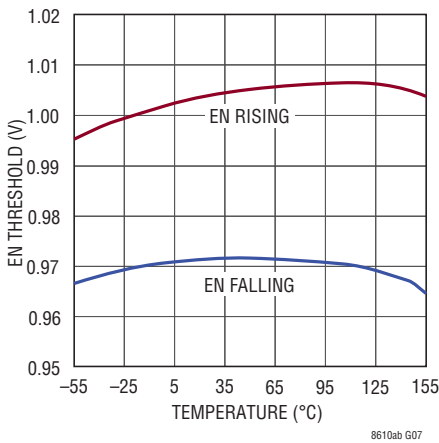

Load Regulation

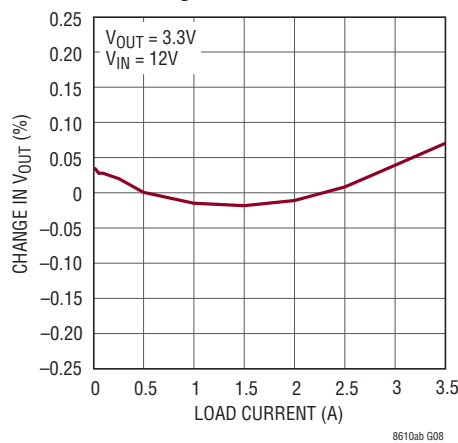

Line Regulation

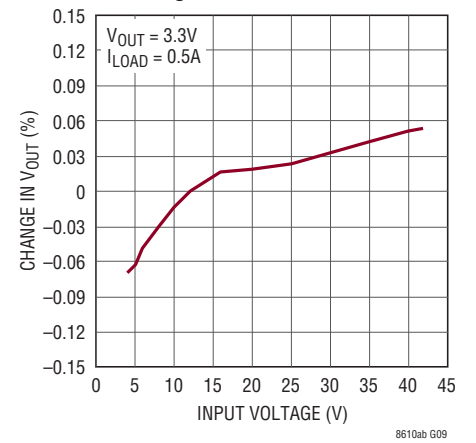

LT8610A No Load Supply Current

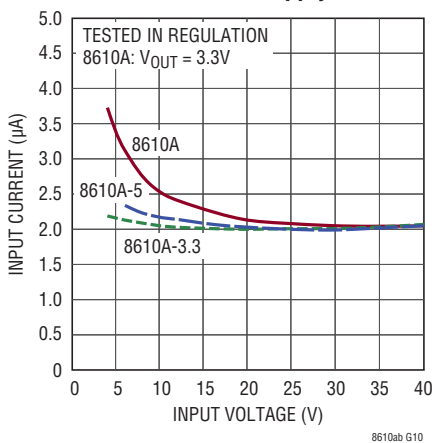

LT8610AB No Load Supply Current

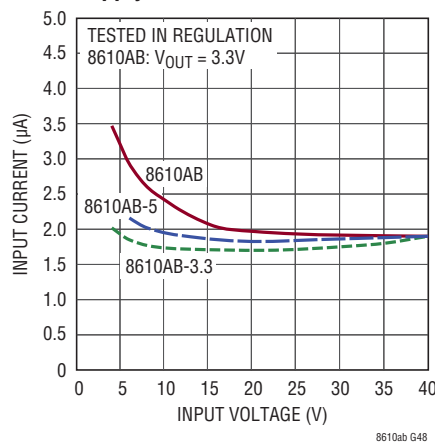

No Load Supply Current

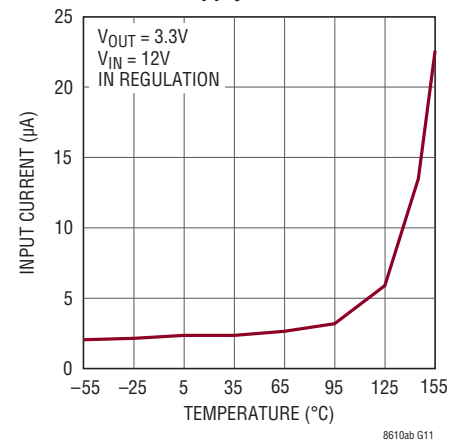

## TYPICAL PERFORMANCE CHARACTERISTICS

**Top FET Current Limit vs Duty Cycle**

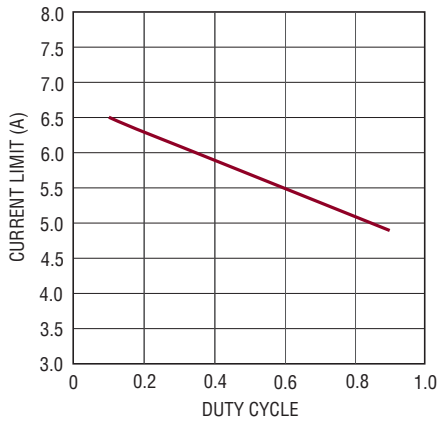

8610ab G13

**Top FET Current Limit**

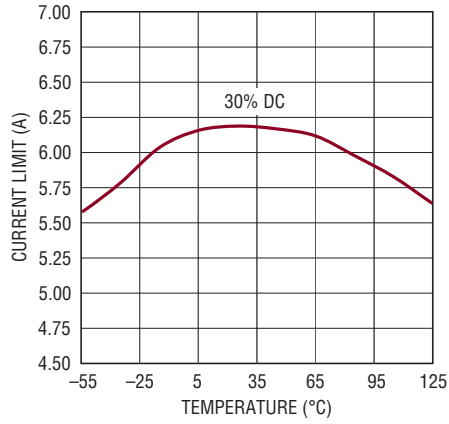

8610ab G14

**Bottom FET Current Limit**

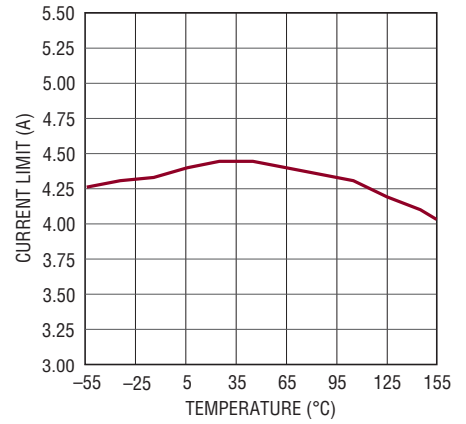

8610ab G15

**Switch Drop**

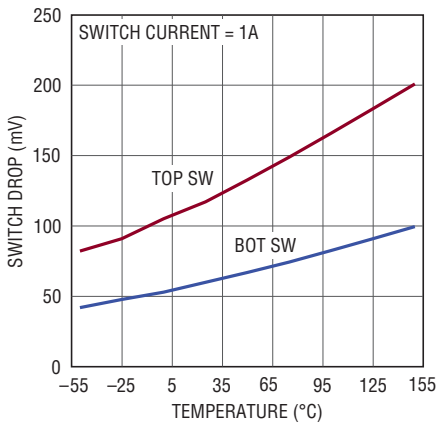

8610ab G40

**Switch Drop**

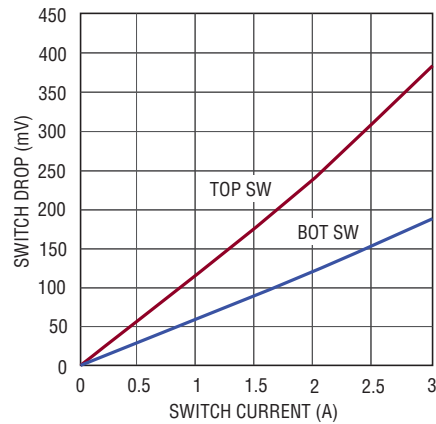

8610ab G41

**Minimum On-Time**

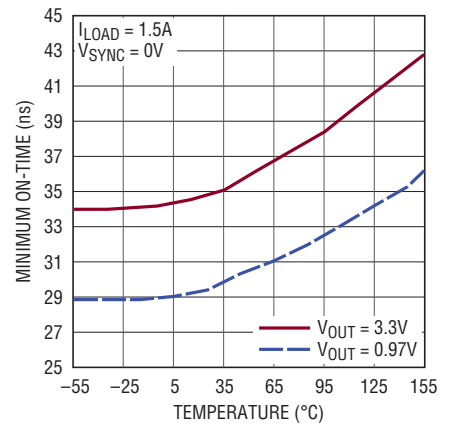

8610ab G17

**Minimum Off-Time**

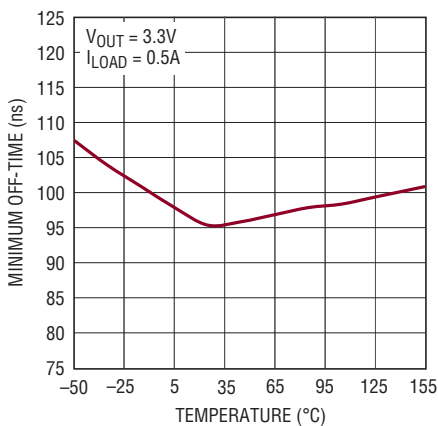

8610ab G18

**Dropout Voltage**

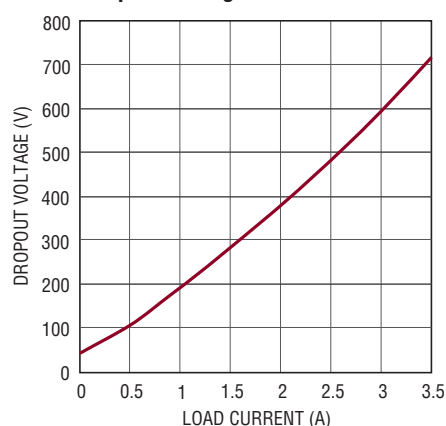

8610ab G19

**Switching Frequency**

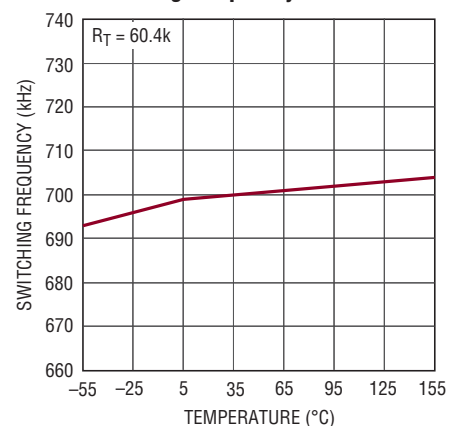

8610ab G20

# LT8610A/LT8610AB Series

## TYPICAL PERFORMANCE CHARACTERISTICS

**Burst Frequency**

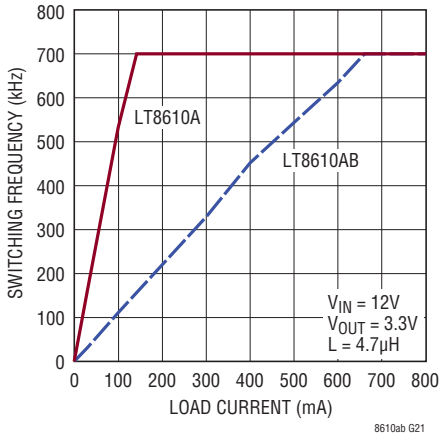

**Minimum Load to Full Frequency**

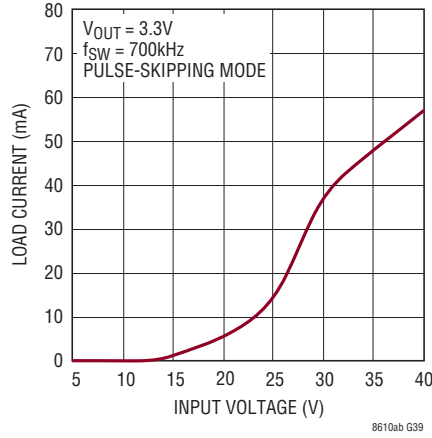

**Frequency Foldback**

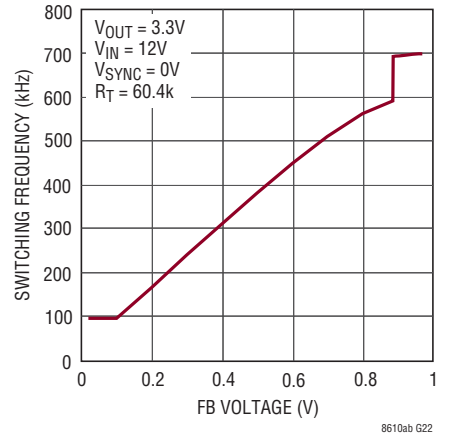

**Soft-Start Tracking**

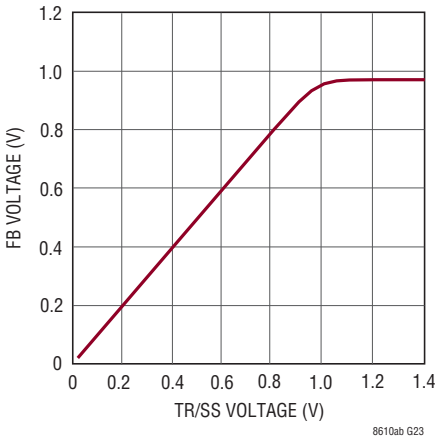

**Soft-Start Current**

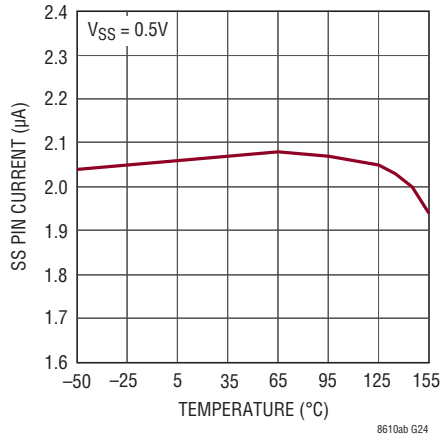

**PG High Thresholds**

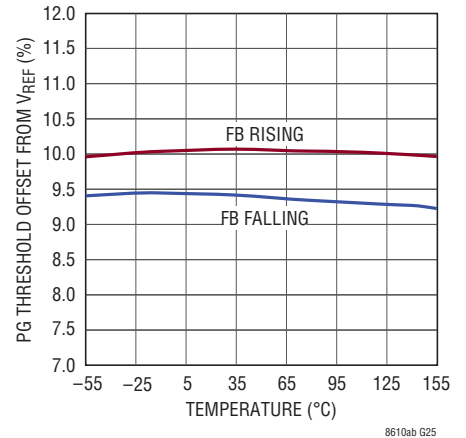

**PG Low Thresholds**

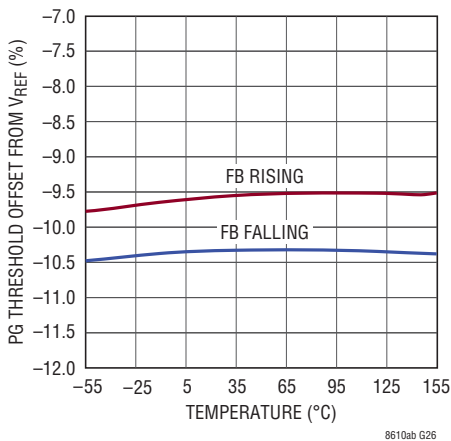

**RT Programmed Switching Frequency**

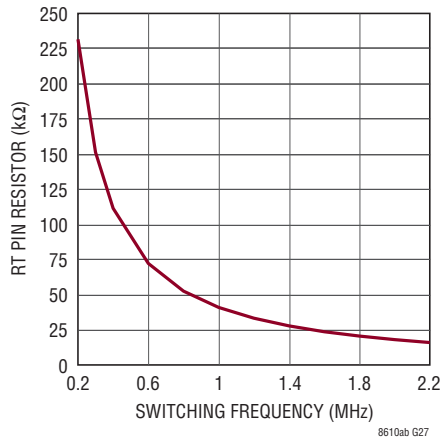

**VIN UVLO**

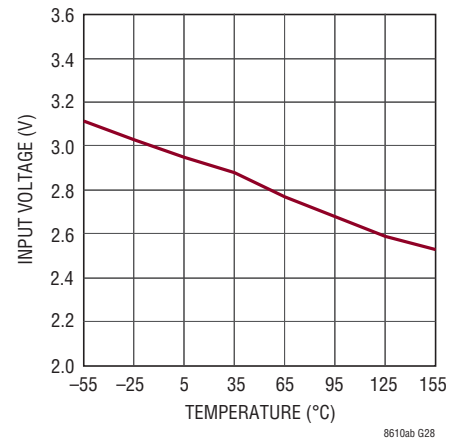

## TYPICAL PERFORMANCE CHARACTERISTICS

**Bias Pin Current**

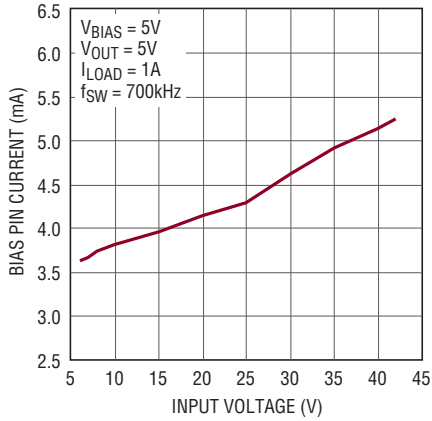

**Bias Pin Current**

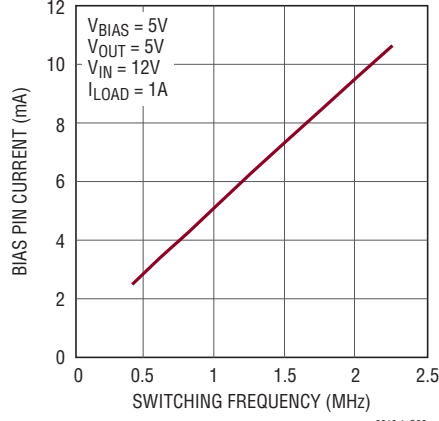

**Switching Waveforms**

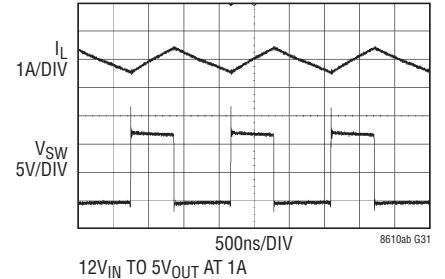

**Switching Waveforms**

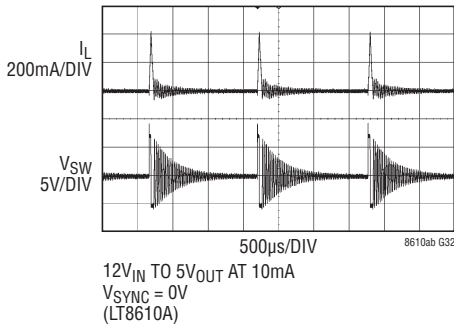

**Switching Waveforms**

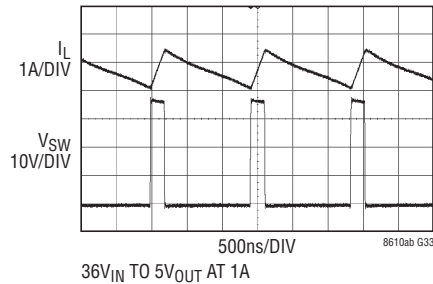

**LT8610A/LT8610AB  
Transient Response**

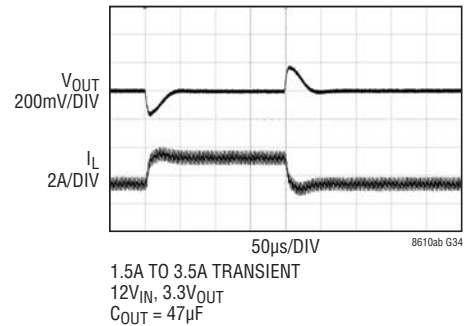

**LT8610A/LT8610AB  
Transient Response**

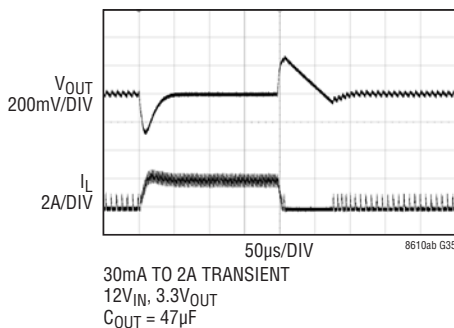

**Start-Up Dropout Performance**

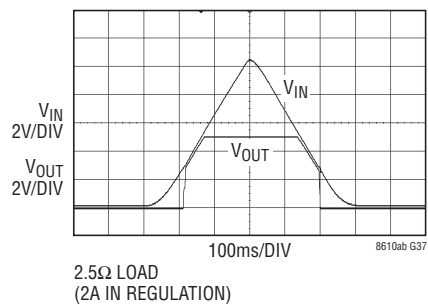

**Start-Up Dropout Performance**

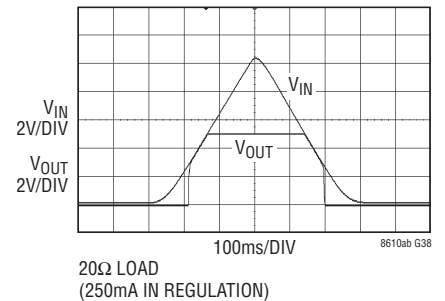

## PIN FUNCTIONS

**SYNC (Pin 1):** External Clock Synchronization Input. Ground this pin for low ripple Burst Mode operation at low output loads. Tie to a clock source for synchronization to an external frequency. Apply a DC voltage of 3V or higher or tie to  $INTV_{CC}$  for pulse-skipping mode. When in pulse-skipping mode, the  $I_Q$  will increase to several hundred  $\mu A$ . Do not float this pin.

**TR/SS (Pin 2):** Output Tracking and Soft-Start Pin. This pin allows user control of output voltage ramp rate during start-up. A TR/SS voltage below 0.97V forces the LT8610A/LT8610AB to regulate the FB pin to equal the TR/SS pin voltage. When TR/SS is above 0.97V, the tracking function is disabled and the internal reference resumes control of the error amplifier. An internal 2.2 $\mu A$  pull-up current from  $INTV_{CC}$  on this pin allows a capacitor to program output voltage slew rate. This pin is pulled to ground with an internal 230 $\Omega$  MOSFET during shutdown and fault conditions; use a series resistor if driving from a low impedance output. This pin may be left floating if the tracking function is not needed.

**RT (Pin 3):** A resistor is tied between RT and ground to set the switching frequency.

**EN/UV (Pin 4):** The LT8610A/LT8610AB is shut down when this pin is low and active when this pin is high. The hysteresic threshold voltage is 1.00V going up and 0.96V going down. Tie to  $V_{IN}$  if the shutdown feature is not used. An external resistor divider from  $V_{IN}$  can be used to program a  $V_{IN}$  threshold below which the LT8610A/LT8610AB will shut down.

**$V_{IN}$  (Pins 5, 6):** The  $V_{IN}$  pins supply current to the LT8610A/LT8610AB internal circuitry and to the internal topside power switch. These pins must be tied together and be locally bypassed. Be sure to place the positive terminal of the input capacitor as close as possible to the  $V_{IN}$  pins, and the negative capacitor terminal as close as possible to the GND pins.

**NC (Pin 7):** No Connect. This pin is not connected to internal circuitry.

**SW (Pins 9, 10, 11):** The SW pins are the outputs of the internal power switches. Tie these pins together and connect them to the inductor and boost capacitor. This node should be kept small on the PCB for good performance.

**BST (Pin 12):** This pin is used to provide a drive voltage, higher than the input voltage, to the topside power switch. Place a 0.1 $\mu F$  boost capacitor as close as possible to the IC.

**$INTV_{CC}$  (Pin 13):** Internal 3.4V Regulator Bypass Pin. The internal power drivers and control circuits are powered from this voltage.  $INTV_{CC}$  maximum output current is 20mA. Do not load the  $INTV_{CC}$  pin with external circuitry.  $INTV_{CC}$  current will be supplied from BIAS if  $V_{BIAS} > 3.1V$ , otherwise current will be drawn from  $V_{IN}$ . Voltage on  $INTV_{CC}$  will vary between 2.8V and 3.4V when  $V_{BIAS}$  is between 3.0V and 3.6V. Decouple this pin to power ground with at least a 1 $\mu F$  low ESR ceramic capacitor placed close to the IC.

**BIAS (Pin 14):** The internal regulator will draw current from BIAS instead of  $V_{IN}$  when BIAS is tied to a voltage higher than 3.1V. For output voltages of 3.3V and above this pin should be tied to  $V_{OUT}$ . If this pin is tied to a supply other than  $V_{OUT}$  use a 1 $\mu F$  local bypass capacitor on this pin.

**PG (Pin 15):** The PG pin is the open-drain output of an internal comparator. PG remains low until the FB pin is within  $\pm 9\%$  of the final regulation voltage, and there are no fault conditions. PG is valid when  $V_{IN}$  is above 3.4V, regardless of EN/UV pin state.

**FB (Pin 16, LT8610A/LT8610AB Only):** The LT8610A/LT8610AB regulates the FB pin to 0.970V. Connect the feedback resistor divider tap to this pin. Also, connect a phase lead capacitor between FB and  $V_{OUT}$ . Typically, this capacitor is 4.7pF to 10pF.

**$V_{OUT}$  (Pin 16, LT8610A-3.3/LT8610A-5/LT8610AB-3.3/LT8610AB-5 Only):** The LT8610A-3.3 and LT8610AB-3.3 regulate the  $V_{OUT}$  pin to 3.3V. This pin connects to a 14.3M $\Omega$  internal feedback divider that programs the fixed output. The LT8610A-5 and LT8610AB-5 regulate the  $V_{OUT}$  pin to 5V. This pin connects to a 12.5M $\Omega$  internal feedback divider that programs the fixed output.

**GND (Pin 8, Exposed Pad Pin 17):** Ground. These pins are the return path of the internal bottom-side switch and must be tied together. Place the negative terminal of the input capacitor as close to the GND pin and exposed pad as possible. The exposed pad must be soldered to the PCB in order to lower the thermal resistance.

**BLOCK DIAGRAM**

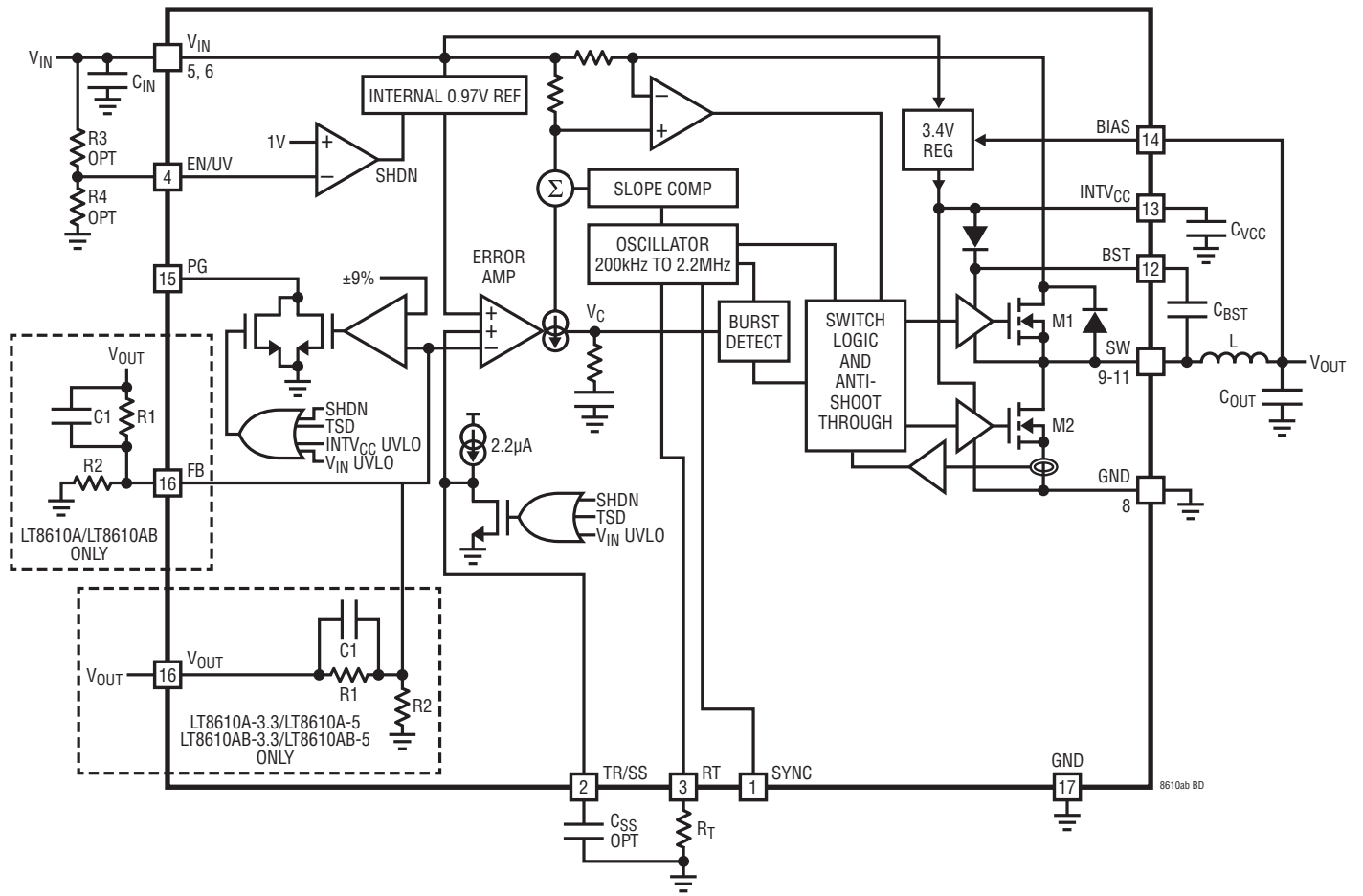

# LT8610A/LT8610AB Series

---

## OPERATION

The LT8610A/LT8610AB is a monolithic, constant frequency, current mode step-down DC/DC converter. An oscillator, with frequency set using a resistor on the RT pin, turns on the internal top power switch at the beginning of each clock cycle. Current in the inductor then increases until the top switch current comparator trips and turns off the top power switch. The peak inductor current at which the top switch turns off is controlled by the voltage on the internal VC node. The error amplifier servos the VC node by comparing the voltage on the V<sub>FB</sub> pin with an internal 0.97V reference. When the load current increases it causes a reduction in the feedback voltage relative to the reference leading the error amplifier to raise the VC voltage until the average inductor current matches the new load current. When the top power switch turns off, the synchronous power switch turns on until the next clock cycle begins or inductor current falls to zero. If overload conditions result in more than 3.3A flowing through the bottom switch, the next clock cycle will be delayed until switch current returns to a safe level.

If the EN/UV pin is low, the LT8610A/LT8610AB is shut down and draws 1 $\mu$ A from the input. When the EN/UV pin is above 1V, the switching regulator will become active.

To optimize efficiency at light loads, the LT8610A/LT8610AB operates in Burst Mode operation in light load situations. Between bursts, all circuitry associated with controlling the output switch is shut down, reducing the input supply current to 1.7 $\mu$ A. In a typical application, 2.5 $\mu$ A will be consumed from the input supply when regulating with no load. The SYNC pin is tied low to use Burst Mode operation and can be tied to a logic high to use pulse-skipping mode. If a clock is applied to the SYNC pin the part will synchronize to an external clock frequency and operate in pulse-skipping mode. While in pulse-skipping

mode the oscillator operates continuously and positive SW transitions are aligned to the clock. During light loads, switch pulses are skipped to regulate the output and the quiescent current will be several hundred  $\mu$ A.

To improve efficiency across all loads, supply current to internal circuitry can be sourced from the BIAS pin when biased at 3.3V or above. Else, the internal circuitry will draw current from V<sub>IN</sub>. The BIAS pin should be connected to V<sub>OUT</sub> if the LT8610A/LT8610AB output is programmed at 3.3V or above.

Comparators monitoring the FB pin voltage (or V<sub>OUT</sub> pin voltages for fixed output versions) will pull the PG pin low if the output voltage varies more than  $\pm 9\%$  (typical) from the set point, or if a fault condition is present.

The oscillator reduces the LT8610A/LT8610AB's operating frequency when the voltage at the FB pin (or V<sub>OUT</sub> pin for fixed output versions) is low. This frequency foldback helps to control the inductor current when the output voltage is lower than the programmed value which occurs during start-up or overcurrent conditions. When a clock is applied to the SYNC pin or the SYNC pin is held DC high, the frequency foldback is disabled and the switching frequency will slow down only during overcurrent conditions.

The LT8610AB differs from the LT8610A in that it has improved efficiency during Burst Mode operation. This comes with the trade-off of increased output voltage ripple, which can be proportionally decreased with an increase in output capacitance. The other trade-off is that the LT8610AB will not reach the full switching frequency programmed by the RT pin resistor until a higher load compared to the LT8610A.

## APPLICATIONS INFORMATION

### Achieving Ultralow Quiescent Current

To enhance efficiency at light loads, the LT8610A/LT8610AB operates in low ripple Burst Mode operation, which keeps the output capacitor charged to the desired output voltage while minimizing the input quiescent current and minimizing output voltage ripple. In Burst Mode operation the LT8610A/LT8610AB delivers single pulses of current to the output capacitor followed by sleep periods where the output power is supplied by the output capacitor. While in sleep mode the LT8610A/LT8610AB consumes 1.7 $\mu$ A.

As the output load decreases, the frequency of single current pulses decreases (see Figure 1a) and the percentage of time the LT8610A/LT8610AB is in sleep mode increases,

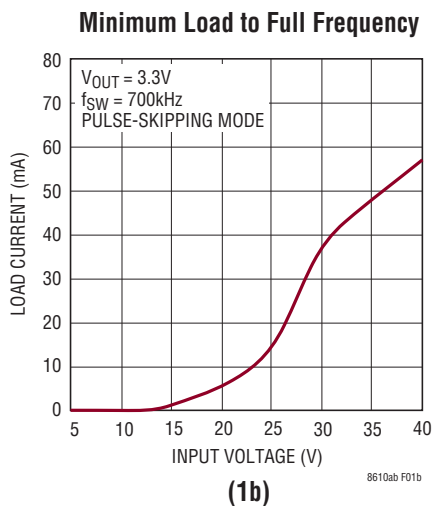
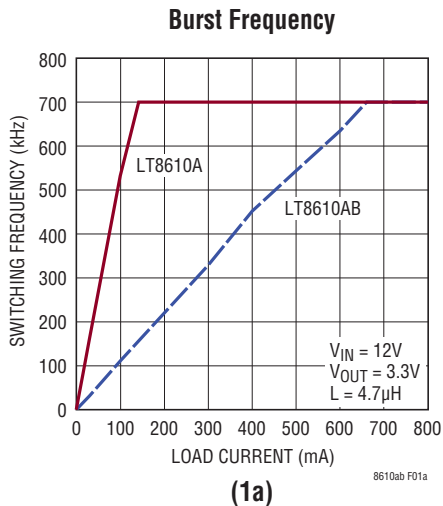

Figure 1. SW Frequency vs Load Information in Burst Mode Operation (1a) and Pulse-Skipping Mode (1b)

resulting in much higher light load efficiency than for typical converters. By maximizing the time between pulses, the converter quiescent current approaches 2.5 $\mu$ A for a typical application when there is no output load. Therefore, to optimize the quiescent current performance at light loads, the current in the feedback resistor divider must be minimized as it appears to the output as load current. The fixed output versions of the LT8610A/LT8610AB series have larger internal feedback resistors than can practically be used externally, so are a good choice for optimizing quiescent current performance.

While in Burst Mode operation the current limit of the top switch is approximately 400mA for the LT8610A resulting in output voltage ripple shown in Figure 2a. The LT8610AB has a 1A current limit in Burst Mode operation, which increases the efficiency but also the output voltage ripple compared to the the LT8610A (Figure 2b). However, increasing the output capacitance will decrease the output ripple proportionally (Table 1). As load ramps upward from zero the switching frequency will increase but only up to the switching frequency programmed by the resistor at the RT pin as shown in Figure 1a. The output load at

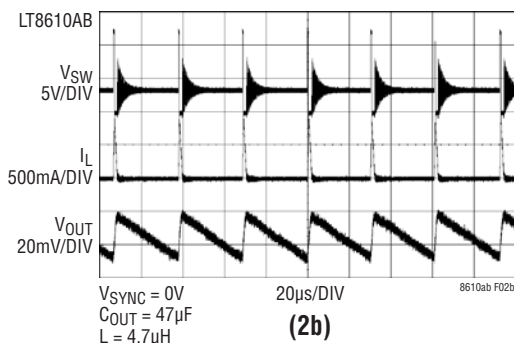
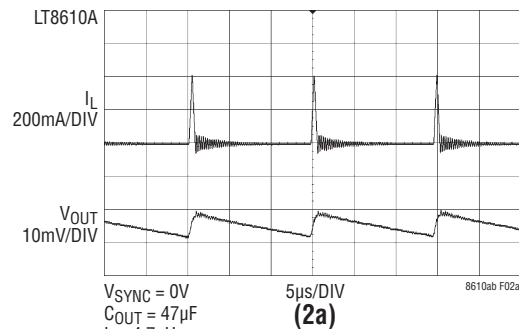

Figure 2. Burst Mode Operation of LT8610A (2a) and LT8610AB (2b)

8610abfa

## APPLICATIONS INFORMATION

which the LT8610A/LT8610AB reaches the programmed frequency varies based on input voltage, output voltage, and inductor choice. However, the output load required to reach full frequency will be higher for the LT8610AB as compared to the LT8610A (Figure 1a).

Inductor value has a very strong effect on Burst Mode efficiency. Larger value inductors allow more charge to be transferred to the output per pulse, which increases both efficiency and output voltage ripple. This dependence on inductance is stronger for the LT8610AB than it is for the LT8610A. If higher efficiency is needed in a Burst Mode application, increasing inductor value can be a quick solution.

**Table 1. Output Voltage Ripple vs Output Capacitance for LT8610AB when  $V_{IN} = 12V$ ,  $V_{OUT} = 3.3V$ , and  $L = 4.7\mu H$**

OUTPUT CAPACITANCE	OUTPUT RIPPLE
47 $\mu$ F	40mV
47 $\mu$ F $\times$ 2	20mV
47 $\mu$ F $\times$ 4	10mV

For some applications it is desirable for the LT8610A/LT8610AB to operate in pulse-skipping mode, offering two major differences from Burst Mode operation. First is the clock stays awake at all times and all switching cycles are aligned to the clock. In this mode much of the internal circuitry is awake at all times, increasing quiescent current to several hundred  $\mu$ A. Second is that full switching frequency is reached at lower output load than in Burst Mode operation (see Figure 1b). To enable pulse-skipping mode, the SYNC pin is tied high either to a logic output or to the INTV<sub>CC</sub> pin. When a clock is applied to the SYNC pin the LT8610A/LT8610AB will also operate in pulse-skipping mode.

### FB Resistor Network

The output voltage is programmed with a resistor divider between the output and the FB pin. Choose the resistor values according to:

$$R1 = R2 \left( \frac{V_{OUT}}{0.970V} - 1 \right) \quad (1)$$

Reference designators refer to the Block Diagram. 1% resistors are recommended to maintain output voltage accuracy.

When using large FB resistors, a 4.7pF to 10pF phase-lead capacitor should be connected from V<sub>OUT</sub> to FB.

The fixed output versions of the LT8610A/LT8610AB series have the feedback resistor network and phase lead capacitor integrated within the part. The FB pin is replaced with a V<sub>OUT</sub> pin for these regulators. The V<sub>OUT</sub> pin can be connected directly to the inductor and output capacitor. The 3.3V fixed output products (LT8610A-3.3/LT8610AB-3.3) have a total of 14.3M of internal feedback divider resistance from the V<sub>OUT</sub> pin to ground. The 5V fixed output products (LT8610A-5/LT8610AB-5) have a total of 12.5M of internal feedback divider resistance from the V<sub>OUT</sub> pin to ground.

If low input quiescent current and good light-load efficiency are desired, use large resistor values for the FB resistor divider. The current flowing in the divider acts as a load current, and will increase the no-load input current to the converter, which is approximately:

$$I_Q = 1.7\mu A + \left( \frac{V_{OUT}}{R1+R2} \right) \left( \frac{V_{OUT}}{V_{IN}} \right) \left( \frac{1}{n} \right) \quad (2)$$

where 1.7 $\mu$ A is the quiescent current of the LT8610A/LT8610AB and the second term is the current in the feedback divider reflected to the input of the buck operating at its light load efficiency n. For a 3.3V application with R1 = 1M and R2 = 412k, the feedback divider draws 2.3 $\mu$ A. With V<sub>IN</sub> = 12V and n = 80%, this adds 0.8 $\mu$ A to the 1.7 $\mu$ A quiescent current resulting in 2.5 $\mu$ A no-load current from the 12V supply. Note that this equation implies that the no-load current is a function of V<sub>IN</sub>; this is plotted in the Typical Performance Characteristics section.

### Setting the Switching Frequency

The LT8610A/LT8610AB uses a constant frequency PWM architecture that can be programmed to switch from 200kHz to 2.2MHz by using a resistor tied from the RT pin to ground. A table showing the necessary R<sub>T</sub> value for a desired switching frequency is in Table 1.

The R<sub>T</sub> resistor required for a desired switching frequency can be calculated using:

$$R_T = \frac{46.5}{f_{SW}} - 5.2 \quad (3)$$

8610abfa

## APPLICATIONS INFORMATION

where  $R_T$  is in  $k\Omega$  and  $f_{SW}$  is the desired switching frequency in MHz.

**Table 1. SW Frequency vs  $R_T$  Value**

$f_{SW}$ (MHz)	$R_T$ ( $k\Omega$ )
0.2	232
0.3	150
0.4	110
0.5	88.7
0.6	71.5
0.7	60.4
0.8	52.3
1.0	41.2
1.2	33.2
1.4	28.0
1.6	23.7
1.8	20.5
2.0	18.2
2.2	15.8

### Operating Frequency Selection and Trade-Offs

Selection of the operating frequency is a trade-off between efficiency, component size, and input voltage range. The advantage of high frequency operation is that smaller inductor and capacitor values may be used. The disadvantages are lower efficiency and a smaller input voltage range.

The highest switching frequency ( $f_{SW(MAX)}$ ) for a given application can be calculated as follows:

$$f_{SW(MAX)} = \frac{V_{OUT} + V_{SW(BOT)}}{t_{ON(MIN)} (V_{IN} - V_{SW(TOP)} + V_{SW(BOT)})} \quad (4)$$

where  $V_{IN}$  is the typical input voltage,  $V_{OUT}$  is the output voltage,  $V_{SW(TOP)}$  and  $V_{SW(BOT)}$  are the internal switch drops ( $\sim 0.42V$ ,  $\sim 0.21V$ , respectively at maximum load) and  $t_{ON(MIN)}$  is the minimum top switch on-time (see the Electrical Characteristics). This equation shows that a slower switching frequency is necessary to accommodate a high  $V_{IN}/V_{OUT}$  ratio.

For transient operation,  $V_{IN}$  may go as high as the absolute maximum rating of 42V regardless of the  $R_T$  value, however the LT8610A/LT8610AB will reduce switching frequency as necessary to maintain control of inductor current to assure safe operation.

The LT8610A/LT8610AB is capable of a maximum duty cycle of greater than 99%, and the  $V_{IN}$ -to- $V_{OUT}$  dropout is limited by the  $R_{DS(ON)}$  of the top switch. In this mode the LT8610A/LT8610AB skips switch cycles, resulting in a lower switching frequency than programmed by  $R_T$ .

For applications that cannot allow deviation from the programmed switching frequency at low  $V_{IN}/V_{OUT}$  ratios use the following formula to set switching frequency:

$$V_{IN(MIN)} = \frac{V_{OUT} + V_{SW(BOT)}}{1 - f_{SW} \cdot t_{OFF(MIN)}} - V_{SW(BOT)} + V_{SW(TOP)} \quad (5)$$

where  $V_{IN(MIN)}$  is the minimum input voltage without skipped cycles,  $V_{OUT}$  is the output voltage,  $V_{SW(TOP)}$  and  $V_{SW(BOT)}$  are the internal switch drops ( $\sim 0.42V$ ,  $\sim 0.21V$ , respectively at maximum load),  $f_{SW}$  is the switching frequency (set by  $R_T$ ), and  $t_{OFF(MIN)}$  is the minimum switch off-time. Note that higher switching frequency will increase the minimum input voltage below which cycles will be dropped to achieve higher duty cycle.

### Inductor Selection and Maximum Output Current

The LT8610A/LT8610AB is designed to minimize solution size by allowing the inductor to be chosen based on the output load requirements of the application. During overload or short-circuit conditions the LT8610A/LT8610AB safely tolerates operation with a saturated inductor through the use of a high speed peak-current mode architecture.

A good first choice for the inductor value is:

$$L = \frac{V_{OUT} + V_{SW(BOT)}}{f_{SW}} \quad (6)$$

where  $f_{SW}$  is the switching frequency in MHz,  $V_{OUT}$  is the output voltage,  $V_{SW(BOT)}$  is the bottom switch drop ( $\sim 0.21V$ ) and  $L$  is the inductor value in  $\mu H$ .

To avoid overheating and poor efficiency, an inductor must be chosen with an RMS current rating that is greater than the maximum expected output load of the application. In addition, the saturation current (typically labeled  $I_{SAT}$ ) rating of the inductor must be higher than the load current plus 1/2 of inductor ripple current:

$$I_{L(PEAK)} = I_{LOAD(MAX)} + \frac{1}{2} \Delta I_L \quad (7)$$

## APPLICATIONS INFORMATION

where  $\Delta I_L$  is the inductor ripple current as calculated in Equation 9 and  $I_{LOAD(MAX)}$  is the maximum output load for a given application.

As a quick example, an application requiring 1A output should use an inductor with an RMS rating of greater than 1A and an  $I_{SAT}$  of greater than 1.3A. During long duration overload or short-circuit conditions, the inductor RMS rating requirement is greater to avoid overheating of the inductor. To keep the efficiency high, the series resistance (DCR) should be less than  $0.04\Omega$ , and the core material should be intended for high frequency applications.

The LT8610A/LT8610AB limits the peak switch current in order to protect the switches and the system from overload faults. The top switch current limit ( $I_{LIM}$ ) is at least 6A at low duty cycles and decreases linearly to 5A at  $DC = 0.8$ . The inductor value must then be sufficient to supply the desired maximum output current ( $I_{OUT(MAX)}$ ), which is a function of the switch current limit ( $I_{LIM}$ ) and the ripple current.

$$I_{OUT(MAX)} = I_{LIM} - \frac{\Delta I_L}{2} \quad (8)$$

The peak-to-peak ripple current in the inductor can be calculated as follows:

$$\Delta I_L = \frac{V_{OUT}}{L \cdot f_{SW}} \cdot \left( 1 - \frac{V_{OUT}}{V_{IN(MAX)}} \right) \quad (9)$$

where  $f_{SW}$  is the switching frequency of the LT8610A/LT8610AB, and  $L$  is the value of the inductor. Therefore, the maximum output current that the LT8610A/LT8610AB will deliver depends on the switch current limit, the inductor value, and the input and output voltages. The inductor value may have to be increased if the inductor ripple current does not allow sufficient maximum output current ( $I_{OUT(MAX)}$ ) given the switching frequency, and maximum input voltage used in the desired application.

The optimum inductor for a given application may differ from the one indicated by this design guide. A larger value inductor provides a higher maximum load current and reduces the output voltage ripple. For applications requiring smaller load currents, the value of the inductor may be lower and the LT8610A/LT8610AB may operate

with higher ripple current. This allows use of a physically smaller inductor, or one with a lower DCR resulting in higher efficiency. Be aware that low inductance may result in discontinuous mode operation, which further reduces maximum load current.

Inductor value has a very strong effect on Burst Mode efficiency. Larger value inductors allow more charge to be transferred to the output per pulse, which increases both efficiency and output voltage ripple. This dependence on inductance is stronger for the LT8610AB than it is for the LT8610A. If higher efficiency is needed in a Burst Mode application, increasing inductor value can be a quick solution.

For more information about maximum output current and discontinuous operation, see Linear Technology's Application Note 44.

Finally, for duty cycles greater than 50% ( $V_{OUT}/V_{IN} > 0.5$ ), a minimum inductance is required to avoid sub-harmonic oscillation. See Application Note 19.

### Input Capacitor

Bypass the input of the LT8610A/LT8610AB circuit with a ceramic capacitor of X7R or X5R type placed as close as possible to the  $V_{IN}$  and PGND pins. Y5V types have poor performance over temperature and applied voltage, and should not be used. A  $4.7\mu F$  to  $10\mu F$  ceramic capacitor is adequate to bypass the LT8610A/LT8610AB and will easily handle the ripple current. Note that larger input capacitance is required when a lower switching frequency is used. If the input power source has high impedance, or there is significant inductance due to long wires or cables, additional bulk capacitance may be necessary. This can be provided with a low performance electrolytic capacitor.

Step-down regulators draw current from the input supply in pulses with very fast rise and fall times. The input capacitor is required to reduce the resulting voltage ripple at the LT8610A/LT8610AB and to force this very high frequency switching current into a tight local loop, minimizing EMI. A  $4.7\mu F$  capacitor is capable of this task, but only if it is placed close to the LT8610A/LT8610AB (see the PCB Layout section). A second precaution regarding the ceramic input capacitor concerns the maximum input voltage rating of the LT8610A/LT8610AB. A ceramic input capacitor combined

## APPLICATIONS INFORMATION

with trace or cable inductance forms a high quality (under damped) tank circuit. If the LT8610A/LT8610AB circuit is plugged into a live supply, the input voltage can ring to twice its nominal value, possibly exceeding the LT8610A/LT8610AB's voltage rating. This situation is easily avoided (see Linear Technology Application Note 88).

### Output Capacitor and Output Ripple

The output capacitor has two essential functions. Along with the inductor, it filters the square wave generated by the LT8610A/LT8610AB to produce the DC output. In this role it determines the output ripple, thus low impedance at the switching frequency is important. The second function is to store energy in order to satisfy transient loads and stabilize the LT8610A/LT8610AB's control loop. Ceramic capacitors have very low equivalent series resistance (ESR) and provide the best ripple performance. For good starting values, see the Typical Applications section.

Use X5R or X7R types. This choice will provide low output ripple and good transient response. Transient performance can be improved with a higher value output capacitor and the addition of a feedforward capacitor placed between  $V_{OUT}$  and FB. Increasing the output capacitance will also decrease the output voltage ripple. A lower value of output capacitor can be used to save space and cost but transient performance will suffer and may cause loop instability. See the Typical Applications in this data sheet for suggested capacitor values.

When choosing a capacitor, special attention should be given to the data sheet to calculate the effective capacitance under the relevant operating conditions of voltage bias and temperature. A physically larger capacitor or one with a higher voltage rating may be required.

### Ceramic Capacitors

Ceramic capacitors are small, robust and have very low ESR. However, ceramic capacitors can cause problems when used with the LT8610A/LT8610AB due to their piezoelectric nature. When in Burst Mode operation, the LT8610A/LT8610AB's switching frequency depends on the load current, and at very light loads the LT8610A/LT8610AB can excite the ceramic capacitor at audio fre-

quencies, generating audible noise. Since the LT8610A/LT8610AB operates at a lower current limit during Burst Mode operation, the noise is typically very quiet to a casual ear. If this is unacceptable, use a high performance tantalum or electrolytic capacitor at the output. Low noise ceramic capacitors are also available.

A final precaution regarding ceramic capacitors concerns the maximum input voltage rating of the LT8610A/LT8610AB. As previously mentioned, a ceramic input capacitor combined with trace or cable inductance forms a high quality (underdamped) tank circuit. If the LT8610A/LT8610AB circuit is plugged into a live supply, the input voltage can ring to twice its nominal value, possibly exceeding the LT8610A/LT8610AB's rating. This situation is easily avoided (see Linear Technology Application Note 88).

### Enable Pin

The LT8610A/LT8610AB is in shutdown when the EN pin is low and active when the pin is high. The rising threshold of the EN comparator is 1.0V, with 40mV of hysteresis. The EN pin can be tied to  $V_{IN}$  if the shutdown feature is not used, or tied to a logic level if shutdown control is required.

Adding a resistor divider from  $V_{IN}$  to EN programs the LT8610A/LT8610AB to regulate the output only when  $V_{IN}$  is above a desired voltage (see the Block Diagram). Typically, this threshold,  $V_{IN(EN)}$ , is used in situations where the input supply is current limited, or has a relatively high source resistance. A switching regulator draws constant power from the source, so source current increases as source voltage drops. This looks like a negative resistance load to the source and can cause the source to current limit or latch low under low source voltage conditions. The  $V_{IN(EN)}$  threshold prevents the regulator from operating at source voltages where the problems might occur. This threshold can be adjusted by setting the values R3 and R4 such that they satisfy the following equation:

$$V_{IN(EN)} = \left( \frac{R3}{R4} + 1 \right) \cdot 1.0V \quad (10)$$

where the LT8610A/LT8610AB will remain off until  $V_{IN}$  is above  $V_{IN(EN)}$ . Due to the comparator's hysteresis, switching will not stop until the input falls slightly below  $V_{IN(EN)}$ .

## APPLICATIONS INFORMATION

When operating in Burst Mode operation for light load currents, the current through the  $V_{IN(EN)}$  resistor network can easily be greater than the supply current consumed by the LT8610A/LT8610AB. Therefore, the  $V_{IN(EN)}$  resistors should be large to minimize their effect on efficiency at low loads.

### INTV<sub>CC</sub> Regulator

An internal low dropout (LDO) regulator produces the 3.4V supply from  $V_{IN}$  that powers the drivers and the internal bias circuitry. The INTV<sub>CC</sub> can supply enough current for the LT8610A/LT8610AB's circuitry and must be bypassed to ground with a minimum of 1 $\mu$ F ceramic capacitor. Good bypassing is necessary to supply the high transient currents required by the power MOSFET gate drivers. To improve efficiency the internal LDO can also draw current from the BIAS pin when the BIAS pin is at 3.1V or higher. Typically the BIAS pin can be tied to the output of the LT8610A/LT8610AB, or can be tied to an external supply of 3.3V or above. If BIAS is connected to a supply other than  $V_{OUT}$ , be sure to bypass with a local ceramic capacitor. If the BIAS pin is below 3.0V, the internal LDO will consume current from  $V_{IN}$ . Applications with high input voltage and high switching frequency where the internal LDO pulls current from  $V_{IN}$  will increase die temperature because of the higher power dissipation across the LDO. Do not connect an external load to the INTV<sub>CC</sub> pin.

### Output Voltage Tracking and Soft-Start

The LT8610A/LT8610AB allows the user to program its output voltage ramp rate by means of the TR/SS pin. An internal 2.2 $\mu$ A pulls up the TR/SS pin to INTV<sub>CC</sub>. Putting an external capacitor on TR/SS enables soft starting the output to prevent current surge on the input supply. During the soft-start ramp the output voltage will proportionally track the TR/SS pin voltage. For output tracking applications, TR/SS can be externally driven by another voltage source. From 0V to 0.97V, the TR/SS voltage will override the internal 0.97V reference input to the error amplifier, thus regulating the FB pin voltage to that of TR/SS pin. In the fixed output voltage options the output voltage will track the TR/SS pin voltage based on a factor set by the internal feedback resistor divider. The 3.3V output options will track to a

voltage 3.4 times that of the TR/SS pin, while the 5V output options will track to a voltage 5.15 times that of the TR/SS pin. When TR/SS is above 0.97V, tracking is disabled and the feedback voltage will regulate to the internal reference voltage. The TR/SS pin may be left floating if the function is not needed.

An active pull-down circuit is connected to the TR/SS pin which will discharge the external soft-start capacitor in the case of fault conditions and restart the ramp when the faults are cleared. Fault conditions that clear the soft-start capacitor are the EN/UV pin transitioning low,  $V_{IN}$  voltage falling too low, or thermal shutdown.

### Output Power Good

When the LT8610A/LT8610AB's output voltage is within the  $\pm 9\%$  window of the regulation point, which is a  $V_{FB}$  voltage in the range of 0.883V to 1.057V (typical), the output voltage is considered good and the open-drain PG pin goes high impedance and is typically pulled high with an external resistor. Otherwise, the internal pull-down device will pull the PG pin low. To prevent glitching both the upper and lower thresholds include 1.3% of hysteresis. This  $\pm 9\%$  power good window around the regulation point is the same for the fixed output options, which for the 3.3V output version corresponds to a 3.003V to 3.597V range (typical) and for the 5V output version corresponds to a 4.55V to 5.45V range (typical).

The PG pin is also actively pulled low during several fault conditions: EN/UV pin is below 1V, INTV<sub>CC</sub> has fallen too low,  $V_{IN}$  is too low, or thermal shutdown.

### Synchronization

To select low ripple Burst Mode operation, tie the SYNC pin below 0.4V (this can be ground or a logic low output). To synchronize the LT8610A/LT8610AB oscillator to an external frequency connect a square wave (with 20% to 80% duty cycle) to the SYNC pin. The square wave amplitude should have valleys that are below 0.4V and peaks above 2.4V (up to 6V).

The LT8610A/LT8610AB will not enter Burst Mode operation at low output loads while synchronized to an external clock, but instead will pulse skip to maintain regulation. The LT8610A/LT8610AB may be synchronized over a 200kHz

8610abfa

## APPLICATIONS INFORMATION

to 2.2MHz range. The  $R_T$  resistor should be chosen to set the LT8610A/LT8610AB switching frequency equal to or below the lowest synchronization input. For example, if the synchronization signal will be 500kHz and higher, the  $R_T$  should be selected for 500kHz. The slope compensation is set by the  $R_T$  value, while the minimum slope compensation required to avoid subharmonic oscillations is established by the inductor size, input voltage, and output voltage. Since the synchronization frequency will not change the slopes of the inductor current waveform, if the inductor is large enough to avoid subharmonic oscillations at the frequency set by  $R_T$ , then the slope compensation will be sufficient for all synchronization frequencies.

For some applications it is desirable for the LT8610A/LT8610AB to operate in pulse-skipping mode, offering two major differences from Burst Mode operation. First is the clock stays awake at all times and all switching cycles are aligned to the clock. Second is that full switching frequency is reached at lower output load than in Burst Mode operation. These two differences come at the expense of increased quiescent current. To enable pulse-skipping mode, the SYNC pin is tied high either to a logic output or to the  $INTV_{CC}$  pin.

The LT8610A/LT8610AB does not operate in forced continuous mode regardless of SYNC signal. Never leave the SYNC pin floating.

### Shorted and Reversed Input Protection

The LT8610A/LT8610AB will tolerate a shorted output. Several features are used for protection during output short-circuit and brownout conditions. The first is the switching frequency will be folded back while the output is lower than the set point to maintain inductor current control. Second, the bottom switch current is monitored such that if inductor current is beyond safe levels switching of the top switch will be delayed until such time as the inductor current falls to safe levels.

Frequency foldback behavior depends on the state of the SYNC pin: If the SYNC pin is low the switching frequency will slow while the output voltage is lower than the programmed level. If the SYNC pin is connected to a clock source or tied high, the LT8610A/LT8610AB will stay at the programmed frequency without foldback and only slow switching if the inductor current exceeds safe levels.

There is another situation to consider in systems where the output will be held high when the input to the LT8610A/LT8610AB is absent. This may occur in battery charging applications or in battery-backup systems where a battery or some other supply is diode ORed with the LT8610A/LT8610AB's output. If the  $V_{IN}$  pin is allowed to float and the EN pin is held high (either by a logic signal or because it is tied to  $V_{IN}$ ), then the LT8610A/LT8610AB's internal circuitry will pull its quiescent current through its SW pin. This is acceptable if the system can tolerate several  $\mu A$  in this state. If the EN pin is grounded the SW pin current will drop to near  $1\mu A$ . However, if the  $V_{IN}$  pin is grounded while the output is held high, regardless of EN, parasitic body diodes inside the LT8610A/LT8610AB can pull current from the output through the SW pin and the  $V_{IN}$  pin. Figure 3 shows a connection of the  $V_{IN}$  and EN/UV pins that will allow the LT8610A/LT8610AB to run only when the input voltage is present and that protects against a shorted or reversed input.

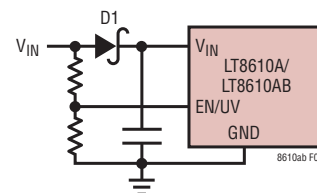
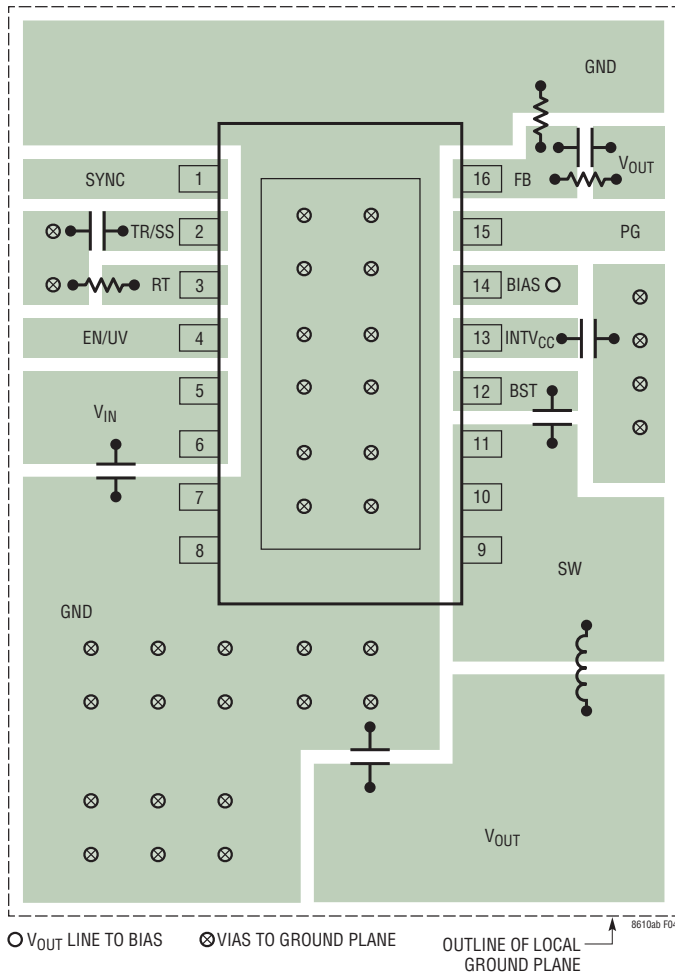

Figure 3. Reverse  $V_{IN}$  Protection

### PCB Layout

For proper operation and minimum EMI, care must be taken during printed circuit board layout. Figure 4 shows the recommended component placement with trace, ground plane and via locations. Note that large, switched currents flow in the LT8610A/LT8610AB's  $V_{IN}$  pins, GND pins, and the input capacitor (C1). The loop formed by the input capacitor should be as small as possible by placing the capacitor adjacent to the  $V_{IN}$  and GND pins. When using a physically large input capacitor the resulting loop may become too large in which case using a small case/value capacitor placed close to the  $V_{IN}$  and GND pins plus a larger capacitor further away is preferred. These components, along with the inductor and output capacitor, should be placed on the same side of the circuit board, and their connections should be made on that layer. Place a local, unbroken ground plane under the application circuit on

## APPLICATIONS INFORMATION



**Figure 4. Recommended PCB Layout for the LT8610A/LT8610AB**

the layer closest to the surface layer. The SW and BOOST nodes should be as small as possible. Finally, keep the FB and RT nodes small so that the ground traces will shield them from the SW and BOOST nodes. The exposed pad on the bottom of the package must be soldered to ground so that the pad is connected to ground electrically and also acts as a heat sink thermally. To keep thermal resistance low, extend the ground plane as much as possible, and add thermal vias under and near the LT8610A/LT8610AB to additional ground planes within the circuit board and on the bottom side.

Unlike the LT8610, the LT8610A/LT8610AB has pin 7 as an NC (no connect) pin. This pin can be soldered to GND to have an LT8610 compatible PCB layout. Alternatively, pin 7

can be left unconnected to help meet PCB clearance and creepage requirements between the  $V_{IN}$  and GND traces.

### High Temperature Considerations

For higher ambient temperatures, care should be taken in the layout of the PCB to ensure good heat sinking of the LT8610A/LT8610AB. The exposed pad on the bottom of the package must be soldered to a ground plane. This ground should be tied to large copper layers below with thermal vias; these layers will spread heat dissipated by the LT8610A/LT8610AB. Placing additional vias can reduce thermal resistance further. The maximum load current should be derated as the ambient temperature approaches the maximum junction rating. Power dissipation within the LT8610A/LT8610AB can be estimated by calculating the total power loss from an efficiency measurement and subtracting the inductor loss. The die temperature is calculated by multiplying the LT8610A/LT8610AB power dissipation by the thermal resistance from junction to ambient. The LT8610A/LT8610AB will stop switching and indicate a fault condition if safe junction temperature is exceeded.

Temperature rise of the LT8610A/LT8610AB is worst when operating at high load, high  $V_{IN}$ , and high switching frequency. If the case temperature is too high for a given application, then either  $V_{IN}$ , switching frequency, or load current can be decreased to reduce the temperature to an acceptable level. Figure 5 shows an example of how case temperature can be managed by reducing  $V_{IN}$ , switching frequency, or load.

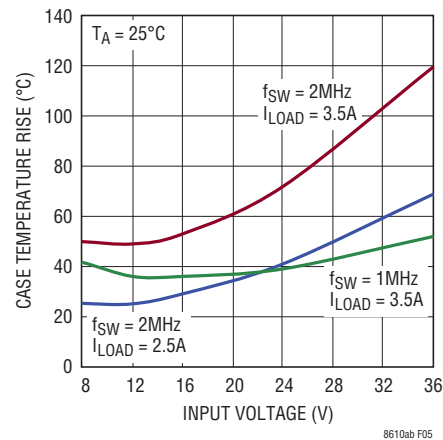

**Figure 5. LT8610AB Case Temperature Rise**

## TYPICAL APPLICATIONS

### 5V 2MHz Step-Down Converter

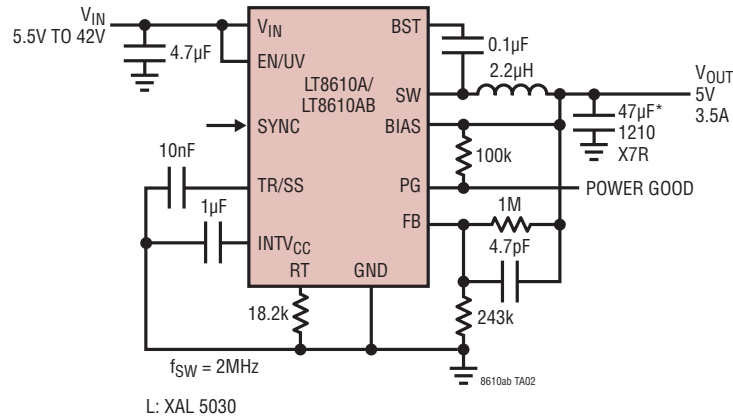

### 12V Step-Down Converter

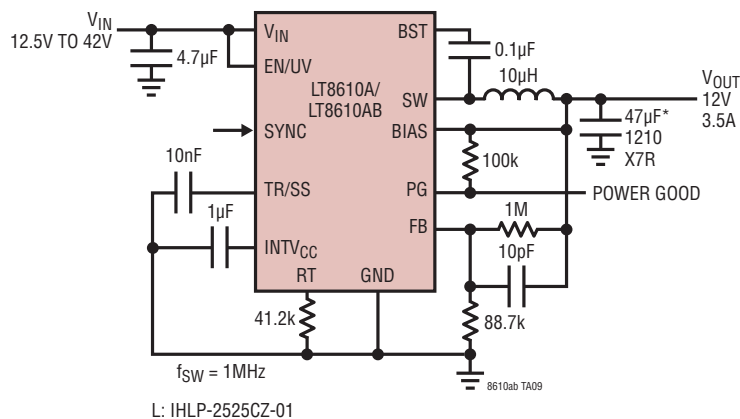

### 5V Step-Down Converter

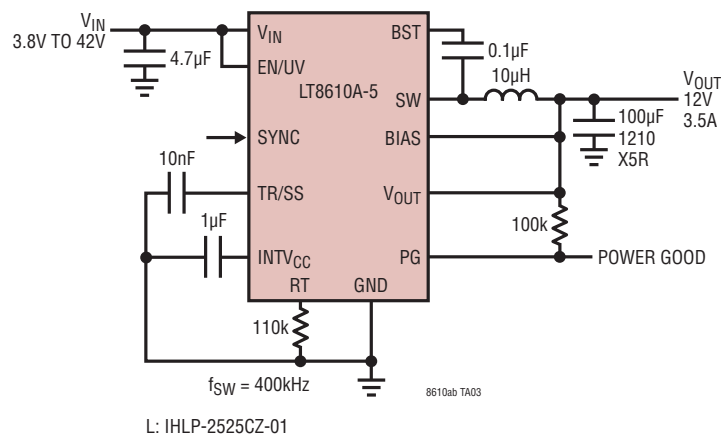

\*Consider doubling output capacitance for LT8610AB if application requires low output voltage ripple in Burst Mode operation.

8610abfa

# LT8610A/LT8610AB Series

## TYPICAL APPLICATIONS

### 1.8V 2MHz Step-Down Converter

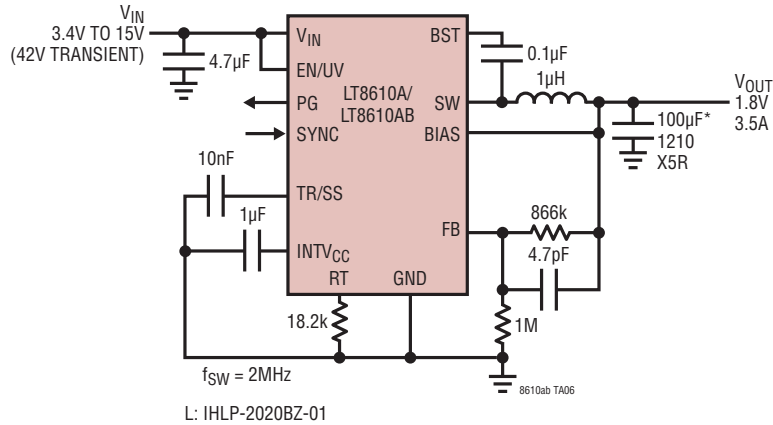

### 3.3V 2MHz Step-Down Converter

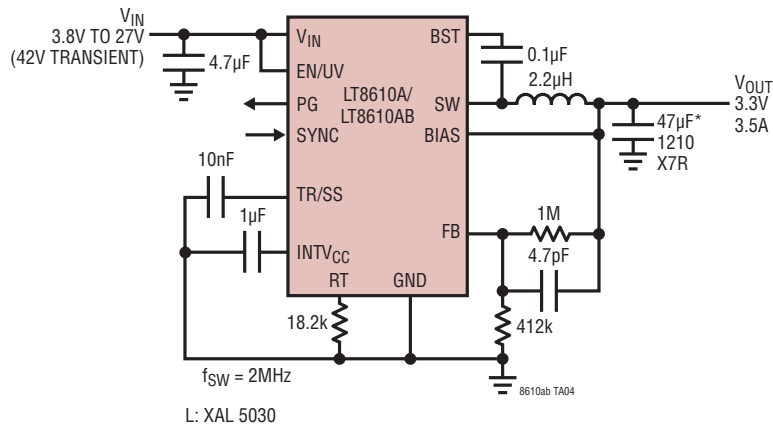

### 1.8V Step-Down Converter

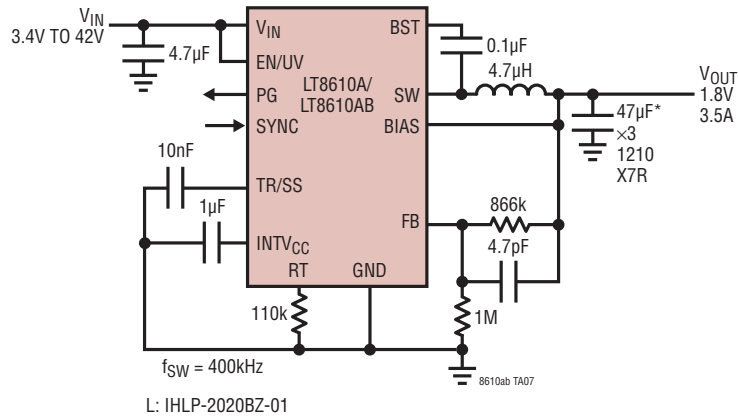

\*Consider doubling output capacitance for LT8610AB if application requires low output voltage ripple in Burst Mode operation.

8610abfa

## TYPICAL APPLICATIONS

### 3.3V Step-Down Converter

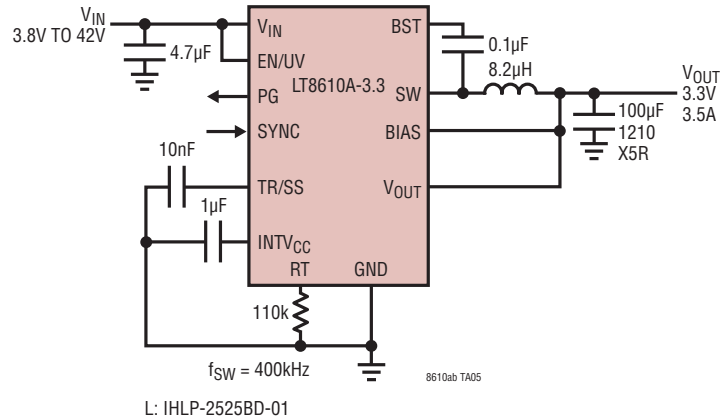

### Ultralow EMI 5V 2.5A Step-Down Converter

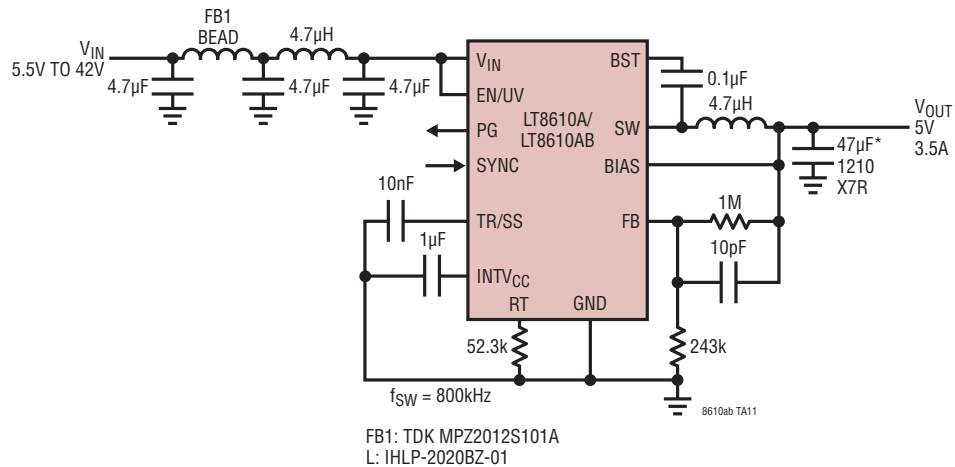

\*Consider doubling output capacitance for LT8610AB if application requires low output voltage ripple in Burst Mode operation.

# LT8610A/LT8610AB Series

## PACKAGE DESCRIPTION

Please refer to <http://www.linear.com/designtools/packaging/> for the most recent package drawings.

### MSE Package 16-Lead Plastic MSOP, Exposed Die Pad (Reference LTC DWG # 05-08-1667 Rev F)

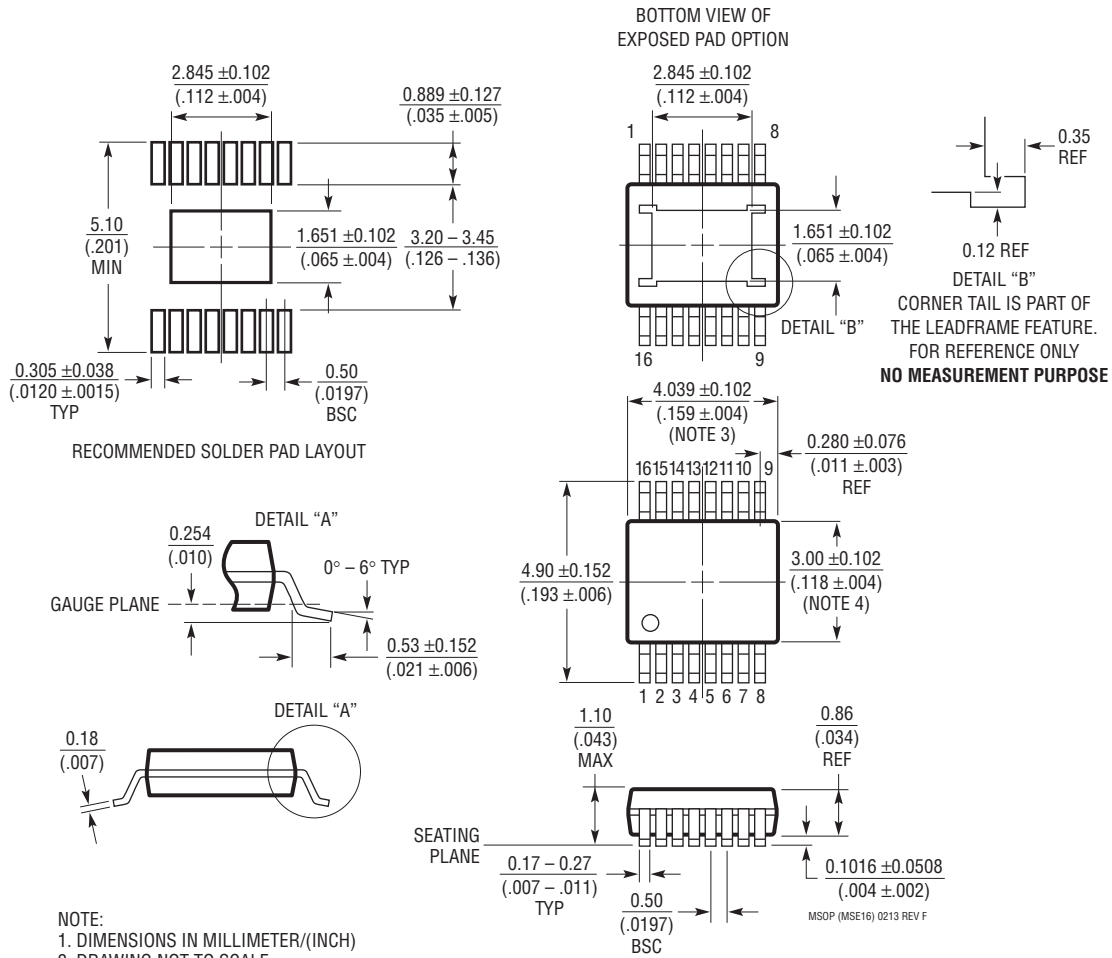

**NOTE:**

1. DIMENSIONS IN MILLIMETER/(INCH)
2. DRAWING NOT TO SCALE
3. DIMENSION DOES NOT INCLUDE MOLD FLASH, PROTRUSIONS OR GATE BURRS.  
MOLD FLASH, PROTRUSIONS OR GATE BURRS SHALL NOT EXCEED 0.152mm (.006") PER SIDE
4. DIMENSION DOES NOT INCLUDE INTERLEAD FLASH OR PROTRUSIONS.  
INTERLEAD FLASH OR PROTRUSIONS SHALL NOT EXCEED 0.152mm (.006") PER SIDE
5. LEAD COPLANARITY (BOTTOM OF LEADS AFTER FORMING) SHALL BE 0.102mm (.004") MAX
6. EXPOSED PAD DIMENSION DOES INCLUDE MOLD FLASH. MOLD FLASH ON E-PAD SHALL NOT EXCEED 0.254mm (.010") PER SIDE.

## REVISION HISTORY

REV	DATE	DESCRIPTION	PAGE NUMBER
A	08/14	Added fixed output options. Clarified Applications Information.	1 - 4, 10, 12, 13 14, 18

# LT8610A/LT8610AB Series

## TYPICAL APPLICATION

### 3.3V and 1.8V with Ratio Tracking

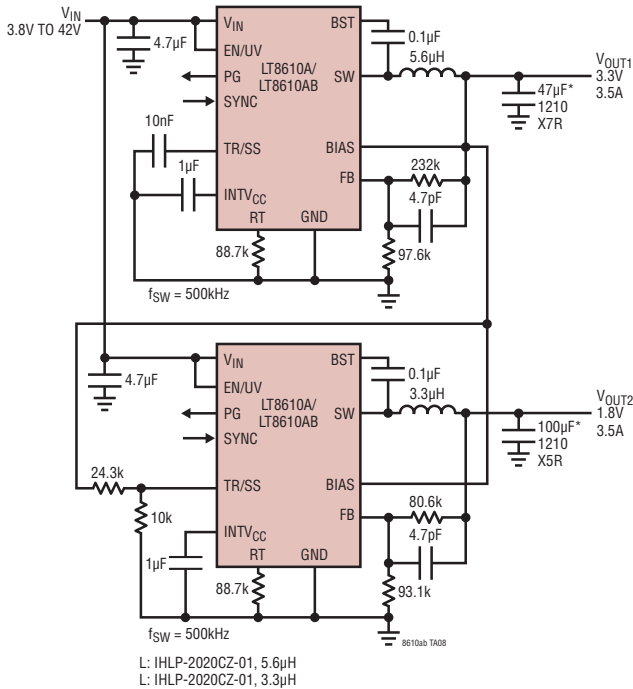

### Ultralow I<sub>Q</sub> 2.5V, 3.3V Step-Down with LDO

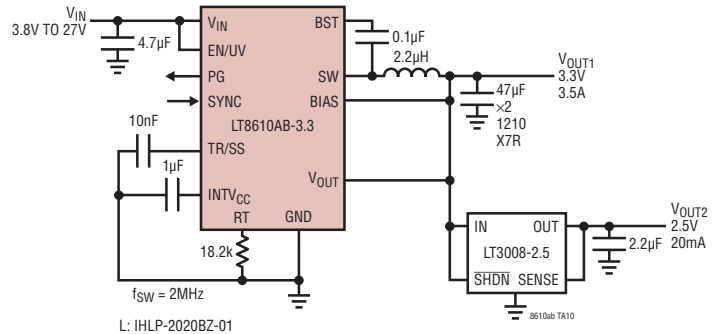

\*Consider doubling output capacitance for LT8610AB if application requires low output voltage ripple in Burst Mode operation.

## RELATED PARTS

PART NUMBER	DESCRIPTION	COMMENTS
LT8610	42V, 2.5A, 96% Efficiency, 2.2MHz Synchronous Micropower Step-Down DC/DC Converter with I <sub>Q</sub> = 2.5µA	V <sub>IN</sub> : 3.4V to 42V, V <sub>OUT(MIN)</sub> = 0.97V, I <sub>Q</sub> = 2.5µA, I <sub>SD</sub> < 1µA, MSOP-16E Package
LT8614	42V, 2.5A with 4A, 96% Efficiency, 2.2MHz Synchronous Micropower Step-Down DC/DC Converter with I <sub>Q</sub> = 2.5µA	V <sub>IN</sub> : 3.4V to 42V, V <sub>OUT(MIN)</sub> = 0.97V, I <sub>Q</sub> = 2.5µA, I <sub>SD</sub> < 1µA, 3mm × 6mm QFN-28 Package
LT8611	42V, 2.5A, 96% Efficiency, 2.2MHz Synchronous Micropower Step-Down DC/DC Converter with I <sub>Q</sub> = 2.5µA and Input/Output Current Limit/Monitor	V <sub>IN</sub> : 3.4V to 42V, V <sub>OUT(MIN)</sub> = 0.97V, I <sub>Q</sub> = 2.5µA, I <sub>SD</sub> < 1µA, 3mm × 5mm QFN-24 Package
LT3690	36V with 60V Transient Protection, 4A, 92% Efficiency, 1.5MHz Synchronous Micropower Step-Down DC/DC Converter with I <sub>Q</sub> = 70µA	V <sub>IN</sub> : 3.9V to 36V, V <sub>OUT(MIN)</sub> = 0.985V, I <sub>Q</sub> = 70µA, I <sub>SD</sub> < 1µA, 4mm × 6mm QFN-26 Package
LT3971	38V, 1.2A, 2.2MHz High Efficiency Micropower Step-Down DC/DC Converter with I <sub>Q</sub> = 2.8µA	V <sub>IN</sub> : 4.2V to 38V, V <sub>OUT(MIN)</sub> = 1.21V, I <sub>Q</sub> = 2.8µA, I <sub>SD</sub> < 1µA, 3mm × 3mm DFN-10 and MSOP-10E Packages
LT3970	40V, 350mA, 2.2MHz High Efficiency Micropower Step-Down DC/DC Converter with I <sub>Q</sub> = 2.5µA	V <sub>IN</sub> : 4.2V to 40V, V <sub>OUT(MIN)</sub> = 1.21V, I <sub>Q</sub> = 2.5µA, I <sub>SD</sub> < 1µA, 3mm × 2mm DFN-10 and MSOP-10 Packages
LT3990	62V, 350mA, 2.2MHz High Efficiency MicroPower Step-Down DC/DC Converter with I <sub>Q</sub> = 2.5µA	V <sub>IN</sub> : 4.2V to 62V, V <sub>OUT(MIN)</sub> = 1.21V, I <sub>Q</sub> = 2.5µA, I <sub>SD</sub> < 1µA, 3mm × 3mm DFN-10 and MSOP-6E Packages
LT3480	36V with Transient Protection to 60V, 2A (I <sub>OUT</sub> ), 2.4MHz, High Efficiency Step-Down DC/DC Converter with Burst Mode Operation	V <sub>IN</sub> : 3.6V to 36V, Transient to 60V, V <sub>OUT(MIN)</sub> = 0.78V, I <sub>Q</sub> = 70µA, I <sub>SD</sub> < 1µA, 3mm × 3mm DFN-10 and MSOP-10E Packages
LT3980	58V with Transient Protection to 80V, 2A (I <sub>OUT</sub> ), 2.4MHz, High Efficiency Step-Down DC/DC Converter with Burst Mode Operation	V <sub>IN</sub> : 3.6V to 58V, Transient to 80V, V <sub>OUT(MIN)</sub> = 0.78V, I <sub>Q</sub> = 85µA, I <sub>SD</sub> < 1µA, 3mm × 4mm DFN-16 and MSOP-16E Packages

8610abfa

## Looking for pricing, stock, or lifecycle information?

Click below to explore more details on WIN SOURCE:

 [View LT8610AHMSE#TRPBF on WIN SOURCE](#)

 [Linear Technology](#) Information

## Optimize Your Supply Chain with WIN SOURCE Solutions

-  Global Sourcing Solution
-  Obsolete Management
-  Cost Control Management
-  Shortage Management
-  Alternative Solution
-  Excess Inventory Management